



US00RE50151E

(19) **United States**
(12) **Reissued Patent**
Kwon et al.

(10) **Patent Number:** **US RE50,151 E**
(45) **Date of Reissued Patent:** ***Oct. 1, 2024**

(54) **LAUNDRY TREATING APPARATUS**

(71) Applicant: **LG ELECTRONICS INC.**, Seoul (KR)

(72) Inventors: **Yongwoo Kwon**, Seoul (KR); **Seungji Yong**, Seoul (KR); **Kangwoon Cheon**, Seoul (KR); **Jaehoon Choi**, Seoul (KR); **Jungjin Park**, Seoul (KR)

(73) Assignee: **LG ELECTRONICS INC.**, Seoul (KR)

(*) Notice: This patent is subject to a terminal disclaimer.

(21) Appl. No.: **17/863,718**

(22) Filed: **Jul. 13, 2022**

Related U.S. Patent Documents

Reissue of:

(64) Patent No.: **10,006,159**
Issued: **Jun. 26, 2018**
Appl. No.: **15/337,206**
Filed: **Oct. 28, 2016**

U.S. Applications:

(63) Continuation of application No. 16/839,431, filed on Apr. 3, 2020, which is an application for the reissue of Pat. No. 10,006,159.

(Continued)

(30) **Foreign Application Priority Data**

Jan. 5, 2016 (KR) 10-2016-0001215
Apr. 1, 2016 (KR) 10-2016-0040448

(51) **Int. Cl.**
D06F 39/14 (2006.01)
D06F 34/05 (2020.01)

(Continued)

(52) **U.S. Cl.**
CPC **D06F 39/14** (2013.01); **D06F 34/32** (2020.02); **D06F 37/266** (2013.01); **G05B 19/10** (2013.01);

(Continued)

(58) **Field of Classification Search**

CPC D06F 39/14; D06F 34/32; D06F 37/266; D06F 34/05; D06F 34/08; G05B 19/409;
(Continued)

(56) **References Cited**

U.S. PATENT DOCUMENTS

3,042,471 A 7/1962 Haslup
5,358,773 A 10/1994 Fujii et al.
(Continued)

FOREIGN PATENT DOCUMENTS

CN 1936157 3/2007
CN 2898087 5/2007

(Continued)

OTHER PUBLICATIONS

U.S. Office Action dated Jun. 22, 2023 issued in U.S. Appl. No. 17/863,687.

(Continued)

Primary Examiner — Krisanne M Jastrzab

(74) *Attorney, Agent, or Firm* — KED & ASSOCIATES, LLP

(57) **ABSTRACT**

A laundry treating apparatus includes a body provided with a laundry inlet; and a door configured to open or close the laundry inlet, wherein the door includes a door frame having a first opening portion facing the laundry inlet and a second opening portion corresponding to a display module mounted at an inside in a state that the door is closed; and a door cover coupled to the door frame to form an appearance of the door, the door cover includes a non-light-transmitting region, and a first light transmitting region corresponding to the first opening portion and a second light transmitting region corresponding to the second opening portion within the non-light-transmitting region, and a mounting guide for an alignment between the first opening portion and the first light transmitting region and an alignment between the second opening portion and the second light transmitting

(Continued)

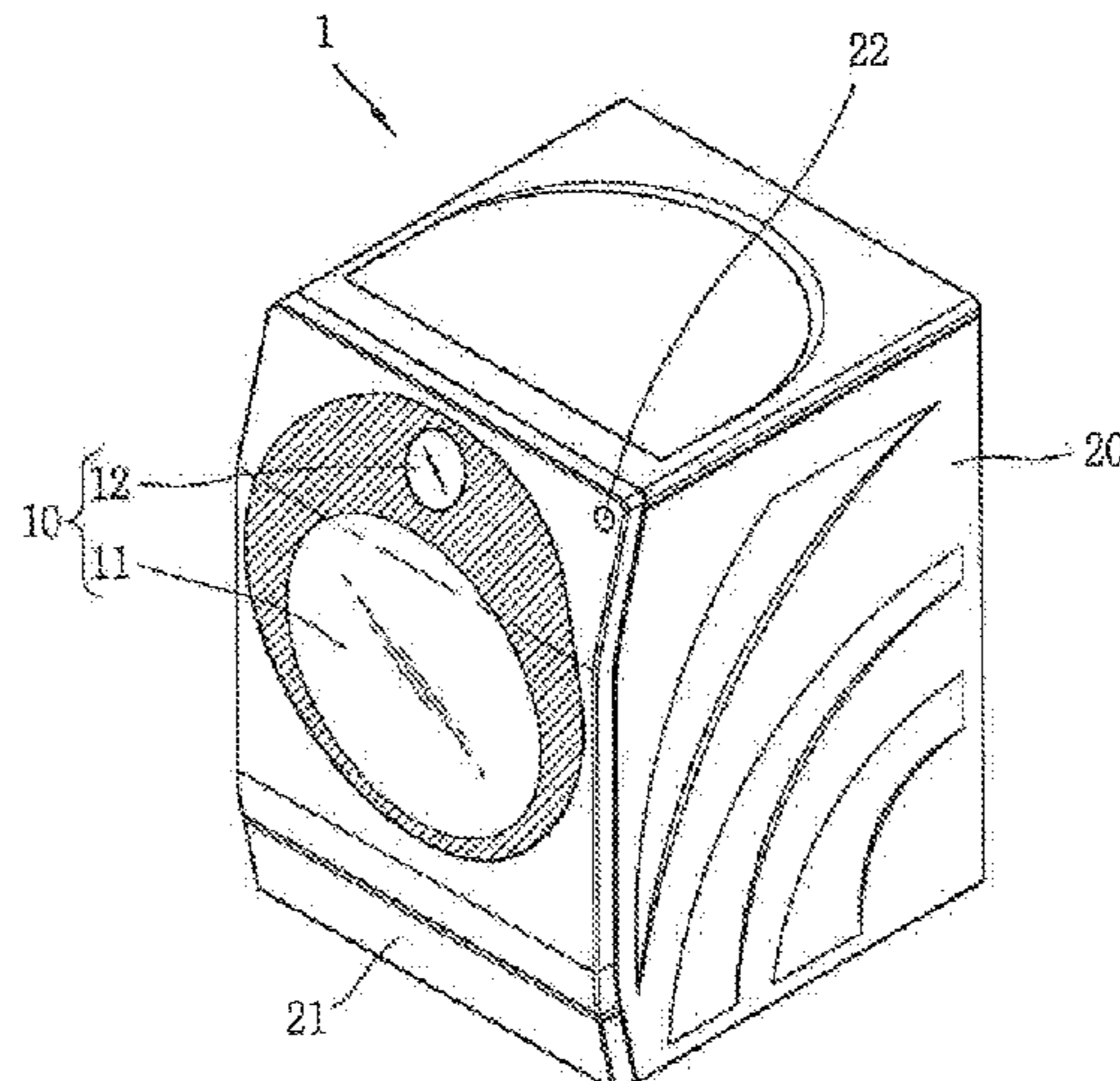

region is provided on at least one of the door frame and door cover during mutual coupling.

19 Claims, 19 Drawing Sheets

Related U.S. Application Data

(60) Provisional application No. 62/249,355, filed on Nov. 2, 2015.

(51) **Int. Cl.**
D06F 34/08 (2020.01)
D06F 34/32 (2020.01)
D06F 37/26 (2006.01)
F16B 11/00 (2006.01)
G05B 19/10 (2006.01)
G05B 19/409 (2006.01)
G06F 3/041 (2006.01)

(52) **U.S. Cl.**
 CPC *G05B 19/409* (2013.01); *G06F 3/041* (2013.01); *D06F 34/05* (2020.02); *D06F 34/08* (2020.02); *F16B 11/006* (2013.01); *G05B 2219/23023* (2013.01); *G05B 2219/23058* (2013.01); *G05B 2219/25087* (2013.01); *G06F 2203/04103* (2013.01)

(58) **Field of Classification Search**
 CPC *G05B 19/10*; *G05B 2219/23058*; *G05B 2219/23023*; *G05B 2219/25087*; *G06F 3/014*; *G06F 2203/04103*; *F16B 11/006*
 See application file for complete search history.

(56) **References Cited**

U.S. PATENT DOCUMENTS

D479,373 S 9/2003 Silva
 6,766,596 B1 7/2004 Bienick
 8,151,603 B2 4/2012 Kang et al.
 D698,508 S 1/2014 Cho et al.
 9,268,068 B2 2/2016 Lee
 D758,028 S 5/2016 Bixby
 9,708,749 B2 7/2017 Woo et al.
 9,810,590 B2 11/2017 Huppi et al.
 10,161,076 B2 12/2018 Kwon
 RE49,269 E 11/2022 Kwon
 2004/0020246 A1 2/2004 Yun et al.
 2006/0059710 A1 3/2006 Kim
 2006/0107702 A1* 5/2006 Kim D06F 39/14
 68/3 R
 2006/0117813 A1 6/2006 Ha et al.
 2006/0218975 A1 10/2006 Graute et al.
 2007/0125132 A1* 6/2007 Hwang D06F 39/14
 68/3 R
 2008/0273016 A1 11/2008 Helgesen
 2009/0064534 A1 3/2009 LeClerc
 2009/0064593 A1 3/2009 Ha
 2009/0121970 A1 5/2009 Ozbek
 2010/0031581 A1 2/2010 Kang et al.
 2010/0116005 A1* 5/2010 Jung D06F 39/12
 29/428
 2010/0187023 A1 7/2010 Min
 2010/0245271 A1 9/2010 Park
 2011/0023560 A1 2/2011 Schuck et al.
 2011/0025178 A1 2/2011 Schone
 2011/0247373 A1* 10/2011 Sharp D06F 37/245
 68/131
 2011/0296628 A1 12/2011 Jenkins et al.
 2012/0036900 A1 2/2012 Hong et al.
 2012/0049703 A1 3/2012 Fang et al.

2012/0086315 A1* 4/2012 Da Riol D06F 39/14
 312/228
 2012/0154989 A1 6/2012 Busalt
 2013/0076220 A1 3/2013 Yeom et al.
 2013/0234573 A1 9/2013 Coxon
 2014/0016290 A1 1/2014 Lee et al.
 2014/0063367 A1 3/2014 Yang et al.
 2014/0157673 A1 6/2014 Bazzinotti
 2015/0123525 A1 5/2015 Woo et al.
 2017/0121886 A1 5/2017 Kwon et al.
 2017/0121898 A1 5/2017 Kwon et al.

FOREIGN PATENT DOCUMENTS

CN 101096810 1/2008
 CN 201103058 8/2008
 CN 101333755 12/2008
 CN 201284424 8/2009
 CN 101805979 8/2010
 CN 101818439 9/2010
 CN 102191653 9/2011
 CN 102317534 1/2012
 CN 202116878 1/2012
 CN 102560960 7/2012
 CN 102733135 10/2012
 CN 204298638 4/2015
 CN 104674521 6/2015
 DE 2 261 275 5/1974
 DE 202 10 707 11/2003
 DE 10-2005-024934 12/2006
 DE 102005058898 12/2006
 DE 20 2009 005 678 6/2009
 DE 10 2009 007 920 4/2010
 DE 10 2013 001 682 9/2013
 DE 10 2013 208 851 11/2014
 EP 1 595 992 11/2005
 EP 2 077 349 7/2009
 EP 2 161 364 3/2010
 EP 2 581 485 4/2013
 EP 2 742 843 6/2014
 EP 2 837 728 2/2015
 EP 2 843 105 3/2015
 EP 2 868 795 5/2015
 EP 3040467 7/2016
 GB 2070130 9/1981
 GB 2 118 580 11/1983
 JP H 08-84891 4/1996
 JP 2006-229319 8/2006
 JP 2011-234785 11/2011
 JP 2013-188273 9/2013
 JP 2014-001984 1/2014
 KR 20-1999-0013707 4/1999
 KR 20-1999-0029441 7/1999
 KR 20-2000-0000962 1/2000
 KR 20-0228519 9/2001
 KR 20-0245382 10/2001
 KR 10-2002-0048576 6/2002
 KR 20-0281165 7/2002
 KR 10-2003-0011457 2/2003
 KR 10-0465690 1/2005
 KR 10-2006-0109164 10/2006
 KR 10-0662289 1/2007
 KR 10-2007-0060063 6/2007
 KR 10-0730925 6/2007
 KR 10-0741111 7/2007
 KR 10-2008-0000442 1/2008
 KR 10-0790539 1/2008
 KR 10-2008-0058123 6/2008
 KR 10-2009-0115005 11/2009
 KR 10-2010-0120049 11/2010
 KR 10-2011-0012307 2/2011
 KR 10-2011-0067886 6/2011
 KR 10-2011-0129902 12/2011
 KR 10-2011-0130089 12/2011
 KR 10-1097306 12/2011
 KR 10-2014-0015017 2/2014
 KR 10-2014-0016197 2/2014
 KR 10-2015-0006262 1/2015
 KR 10-2015-0006264 1/2015

(56)

References Cited

FOREIGN PATENT DOCUMENTS

KR	10-2015-0061144	6/2015
KR	10-2015-0066140	6/2015
KR	10-2015-0090754	8/2015
KR	10-2015-0120230	10/2015
KR	10-2015-0138903	12/2015
WO	WO 2005/075727	8/2005
WO	WO 2010/094959	8/2010
WO	WO 2010/128729	11/2010
WO	WO 2011/014018	2/2011
WO	WO 2011/069814	6/2011
WO	WO 2011/149319	12/2011
WO	WO 2014/024393	2/2014
WO	WO 2016/078191	5/2016

OTHER PUBLICATIONS

U.S. Office Action dated Apr. 20, 2018 issued in co-pending U.S. Appl. No. 15/339,055 (p. 1456).

U.S. Notice of Allowance dated Jan. 23, 2018 issued in U.S. Appl. No. 15/338,874 (p. 1452).

U.S. Notice of Allowance dated Mar. 2, 2018 issued in U.S. Appl. No. 15/337,689 (p. 1451).

U.S. Office Action dated Mar. 22, 2018 issued in U.S. Appl. No. 15/337,586 (p. 1454).

U.S. Office Action dated Apr. 6, 2018 issued in U.S. Appl. No. 15/335,852 (p. 1449).

U.S. Office Action dated Nov. 30, 2017 issued in U.S. Appl. No. 15/337,689 (p. 1451).

U.S. Office Action dated Jan. 25, 2018 issued in U.S. Appl. No. 15/340,235 (p. 1453).

U.S. Office Action dated Feb. 22, 2018 issued in U.S. Appl. No. 15/339,265 (p. 1457).

U.S. Office Action dated Sep. 25, 2017 issued in U.S. Appl. No. 15/340,235 (p. 1453).

U.S. Office Action dated Sep. 28, 2017 issued in U.S. Appl. No. 15/338,874 (p. 1452).

Korean Office Action dated May 31, 2016 issued in Application No. KR 10-2016-0040448 (with English Translation).

Indian Office Action dated Feb. 28, 2020 issued in Application No. 201837016444.

Japanese Office Action dated Nov. 10, 2020 issued in Application No. 2018-542079 (English translation attached).

Russian Office Action dated Dec. 21, 2018 issued in Application No. 2018120146 (English translation attached).

European Search Report dated May 18, 2021 issued in Application No. 21151372.6.

Merriam-Webster Online Dictionary, definition of “adhere” retrieved Mar. 24, 2022. <URL: <https://merriam-webster.com/dictionary/adhere>>. (Year: 2022).

U.S. Office Action dated Apr. 11, 2022 issued in U.S. Appl. No. 16/839,431.

U.S. Office Action dated Nov. 16, 2021 issued in U.S. Appl. No. 16/839,431.

U.S. Appl. No. 17/863,637, filed Jul. 13, 2022.

U.S. Appl. No. 17/863,670, filed Jul. 13, 2022.

U.S. Appl. No. 17/863,687, filed Jul. 13, 2022.

U.S. Appl. No. 17/863,718, filed Jul. 13, 2022.

U.S. Appl. No. 17/863,746, filed Jul. 13, 2022.

U.S. Appl. No. 17/863,774, filed Jul. 13, 2022.

U.S. Office Action dated Jun. 13, 2023 issued in U.S. Appl. No. 17/863,637.

U.S. Office Action dated Aug. 28, 2023 issued in U.S. Appl. No. 17/863,746.

U.S. Office Action dated Jul. 18, 2023 issued in U.S. Appl. No. 17/863,670.

Korean Search Report dated Apr. 15, 2016 issued in Application No. 10-2016-0040447.

Korean Search Report dated Apr. 15, 2016 issued in Application No. 10-2016-0040450.

Korean Office Action dated Apr. 15, 2016 issued in Application No. 10-2016-0040451.

Korean Search Report dated Apr. 15, 2016 issued in Application No. 10-2016-0040453.

Korean Search Report dated Apr. 15, 2016 issued in Application No. 10-2016-0040455.

Korean Search Report dated Apr. 15, 2016 issued in Application No. 10-2016-0040456.

Korean Search Report dated Apr. 15, 2016 issued in Application No. 10-2016-0040457.

Korean Office Action dated Apr. 20, 2016 issued in Application No. 10-2016-0040455.

Korean Office Action dated Apr. 20, 2016 issued in Application No. 10-2016-0040456.

Korean Office Action dated Apr. 20, 2016 issued in Application No. 10-2016-0040457.

Korean Office Action dated May 5, 2016 issued in Application No. 10-2016-0040450.

Korean Office Action dated May 19, 2016 issued in Application No. 10-2016-0040453.

Korean Office Action dated Jun. 20, 2016 issued in Application No. 10-2016-0040447.

Korean Office Action dated Jun. 21, 2016 issued in Application No. 10-2016-0040452.

European Search Report dated Mar. 29, 2017 issued in Application No. 16196148.7.

Korean Office Action dated Mar. 30, 2017 issued in Application No. 10-2016-0040455.

European Search Report dated Mar. 31, 2017 issued in Application No. 16196150.3.

European Search Report dated Apr. 3, 2017 issued in Application No. 16196149.5.

European Search Report dated Apr. 5, 2017 issued in Application No. 16196185.9.

European Search Report dated Apr. 9, 2017 issued in Application No. 16196353.3.

European Search Report dated Apr. 10, 2017 issued in Application No. 16196360.8.

European Search Report dated Apr. 11, 2017 issued in Application No. 16196340.0.

European Search Report dated Apr. 11, 2017 issued in Application No. 16196351.7.

European Search Report dated Apr. 18, 2017 issued in Application No. EP16196298.0.

Chinese Office Action dated May 3, 2017 issued in Application No. 201610452886.2 (with English Translation).

Chinese Office Action dated May 27, 2017 issued in Application No. 201610457444.7 (with English translation).

Chinese Office Action dated Jun. 26, 2017 issued in Application No. 201610452893.2 (with English translation).

Chinese Office Action dated Aug. 3, 2017 issued in Application No. 201610509856.0 (with English translation).

U.S. Office Action dated Sep. 25, 2017 issued in U.S. Appl. No. 15/340,235.

U.S. Office Action dated Sep. 28, 2017 issued in U.S. Appl. No. 15/338,874.

Korean Office Action dated Sep. 26, 2017 issued in Application No. 10-2016-0040456.

Chinese Office Action dated Sep. 28, 2017 issued in Application No. 201610460998.2 (with English translation).

Chinese Office Action dated Oct. 10, 2017 issued in Application No. 201610461531.X (with English translation).

Chinese Office Action dated Oct. 18, 2017 issued in Application No. 201610482128.5 (with English translation).

Korean Search Report dated Apr. 15, 2016 issued in Application No. 10-2016-0040448.

Korean Office Action dated May 31, 2016 issued in Application No. 10-2016-0040448.

Korean Office Action dated Nov. 15, 2016 issued in Application No. 10-2016-0040455.

Korean Office Action dated Nov. 15, 2016 issued in Application No. 10-2016-0040456.

(56)

References Cited

OTHER PUBLICATIONS

Korean Office Action dated Nov. 16, 2016 issued in Application No. 10-2016-0040457.

Korean Office Action dated May 31, 2016 issued in Application No. 10-2016-0040448 (with English Translation).

Korean Decision of Rejection dated Oct. 31, 2016 issued in Application No. KR 10-2016-0040448 (with English Translation).

Korean Notice of Allowance dated Dec. 26, 2016 issued in Application No. KR 10-2016-0040448 (with English Translation).

Machine English Translation of KR 1020150006264 (Year: 2015).

U.S. Office Action dated Nov. 30, 2017 issued in U.S. Appl. No. 15/337,689.

U.S. Office Action dated Jan. 25, 2018 issued in U.S. Appl. No. 15/340,235.

U.S. Office Action dated Feb. 22, 2018 issued in U.S. Appl. No. 15/339,265.

International Search Report dated Jan. 23, 2017 issued Application No. PCT/KR2016/012366.

International Search Report dated Jan. 24, 2017 issued Application No. PCT/KR2016/012365.

International Search Report dated Jan. 25, 2017 issued Application No. PCT/KR2016/012361.

U.S. Notice of Allowance dated Jan. 23, 2018 issued in U.S. Appl. No. 15/338,874.

U.S. Notice of Allowance dated Mar. 2, 2018 issued in U.S. Appl. No. 15/337,689.

U.S. Office Action dated Mar. 22, 2018 issued in U.S. Appl. No. 15/337,586.

U.S. Office Action dated Apr. 6, 2018 issued in U.S. Appl. No. 15/335,852.

KR 2002-0048576 (previously cited) Translated Description, 5 pages (Year: 2002).

CN 201103058Y (previously cited) Translated Description, 11 pages (Year: 2008).

U.S. Office Action dated Apr. 20, 2018 issued in co-pending U.S. Appl. No. 15/339,055.

* cited by examiner

FIG. 1

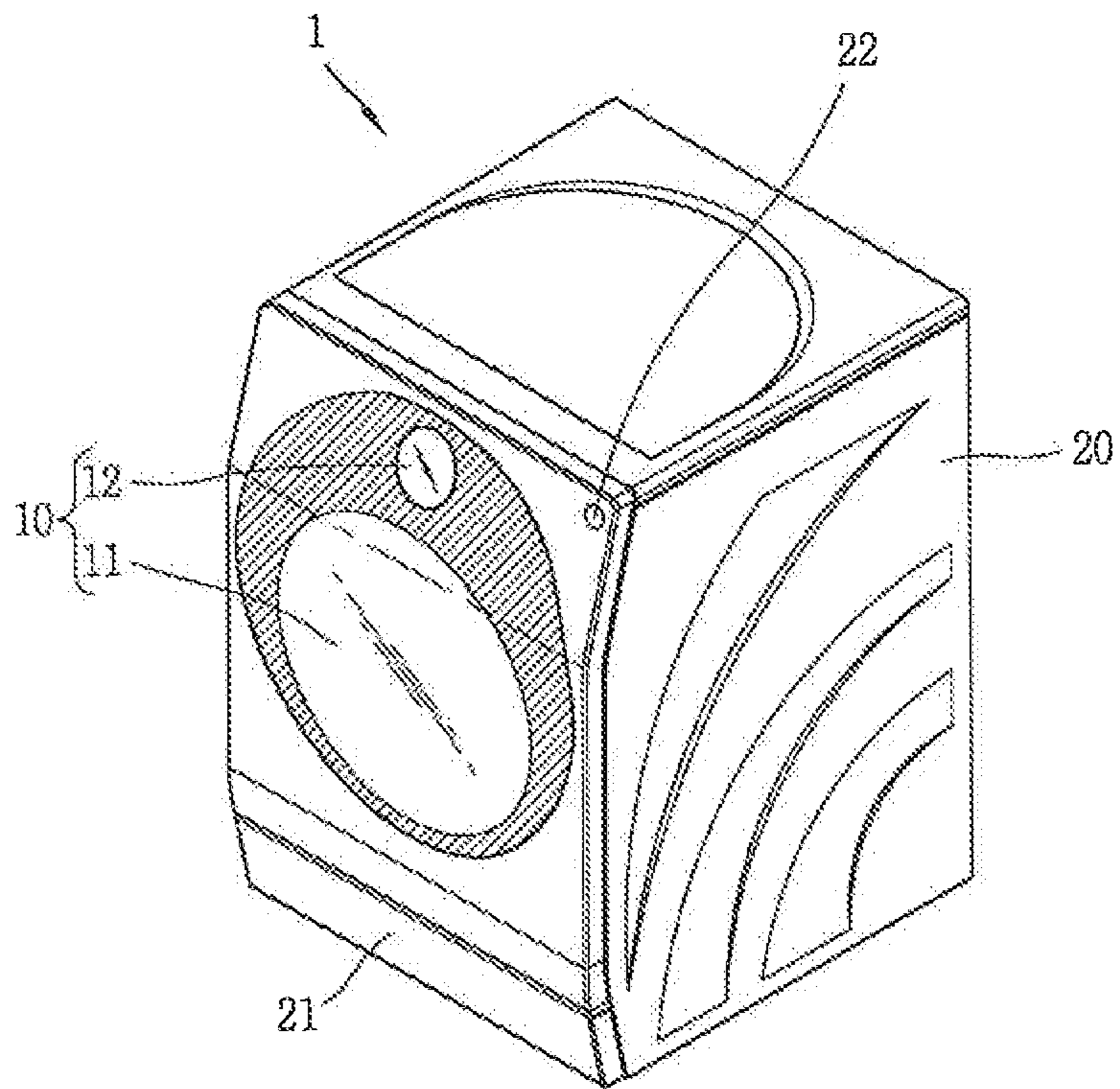

FIG. 2A

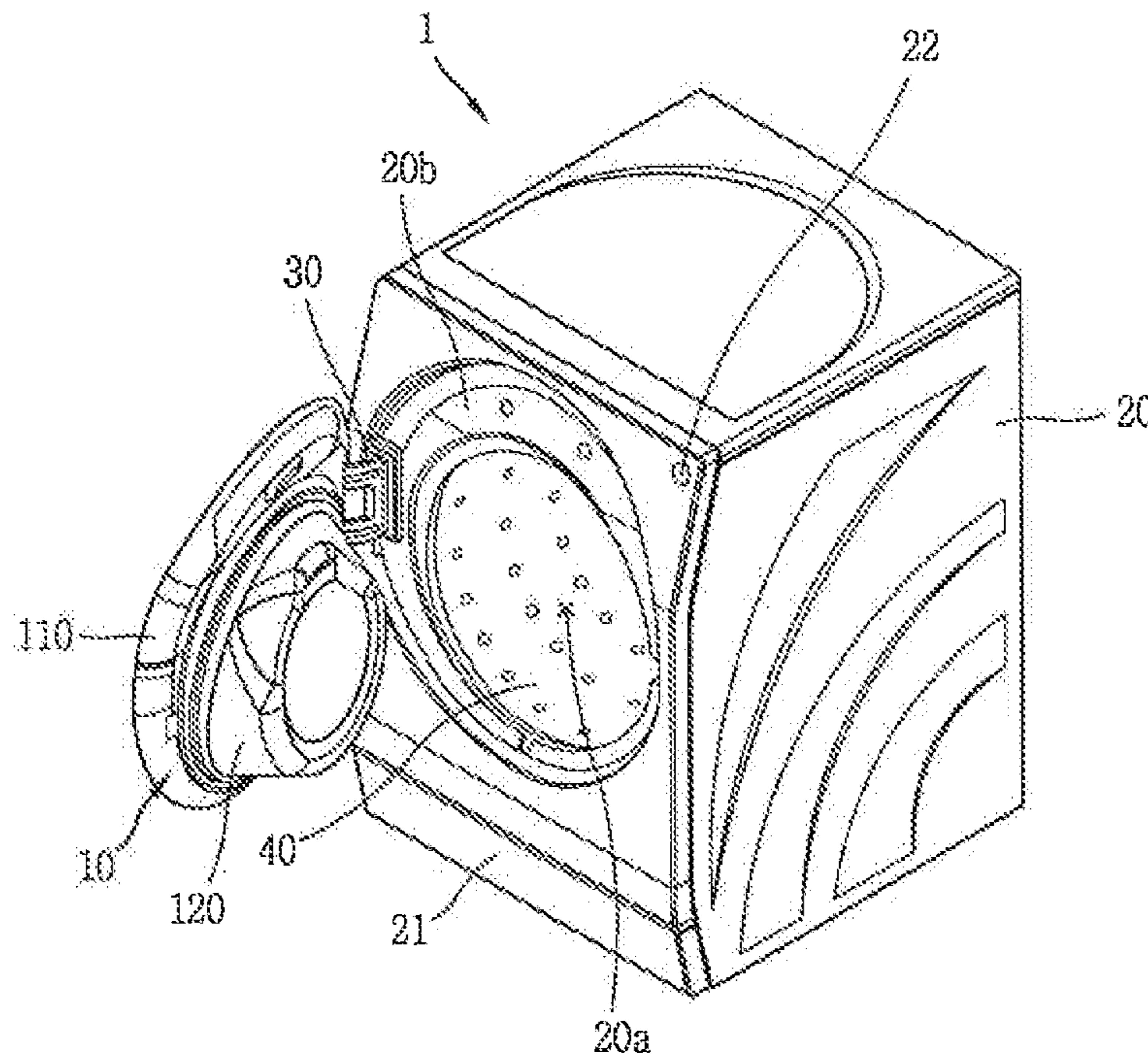

FIG. 2B

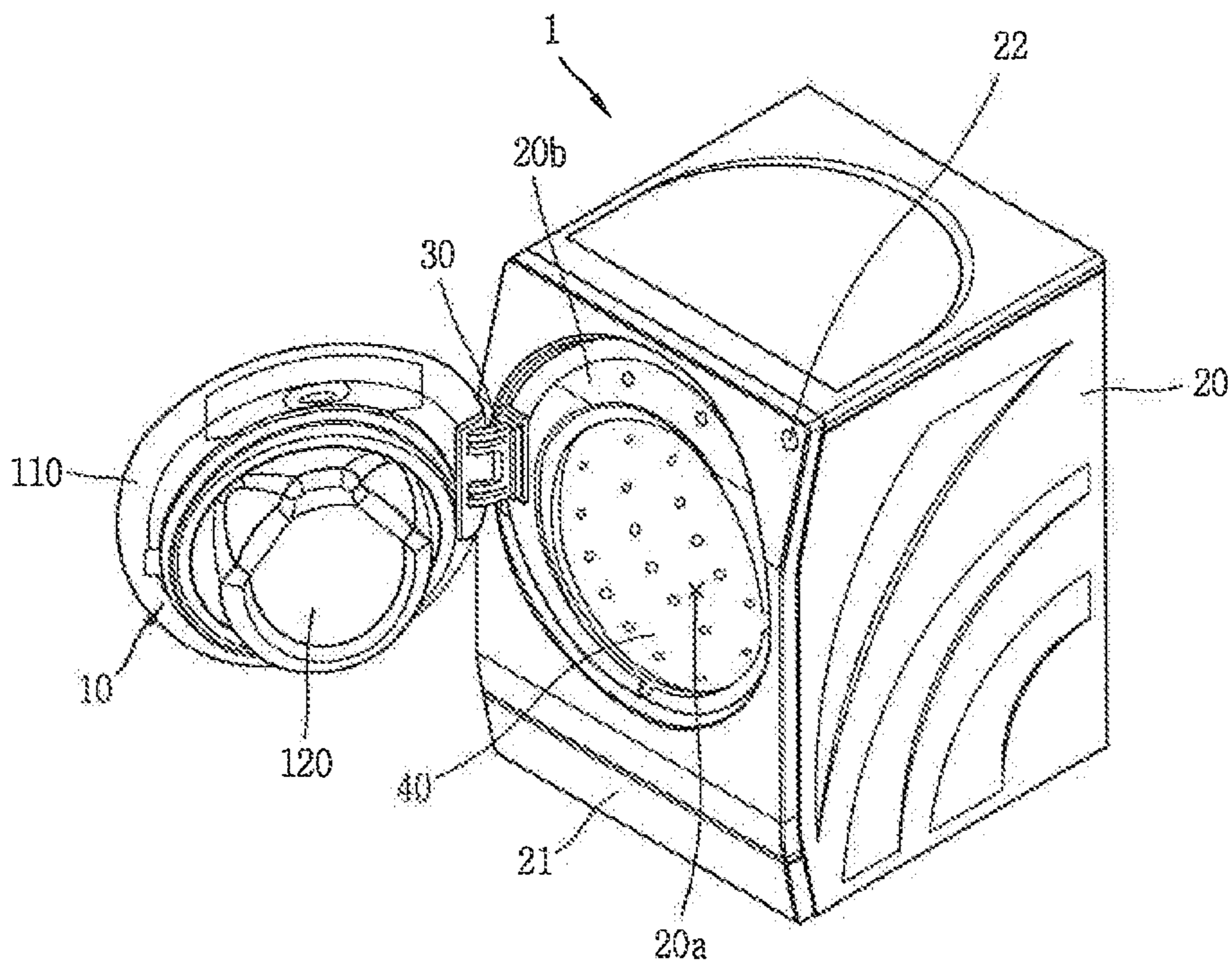

FIG. 3

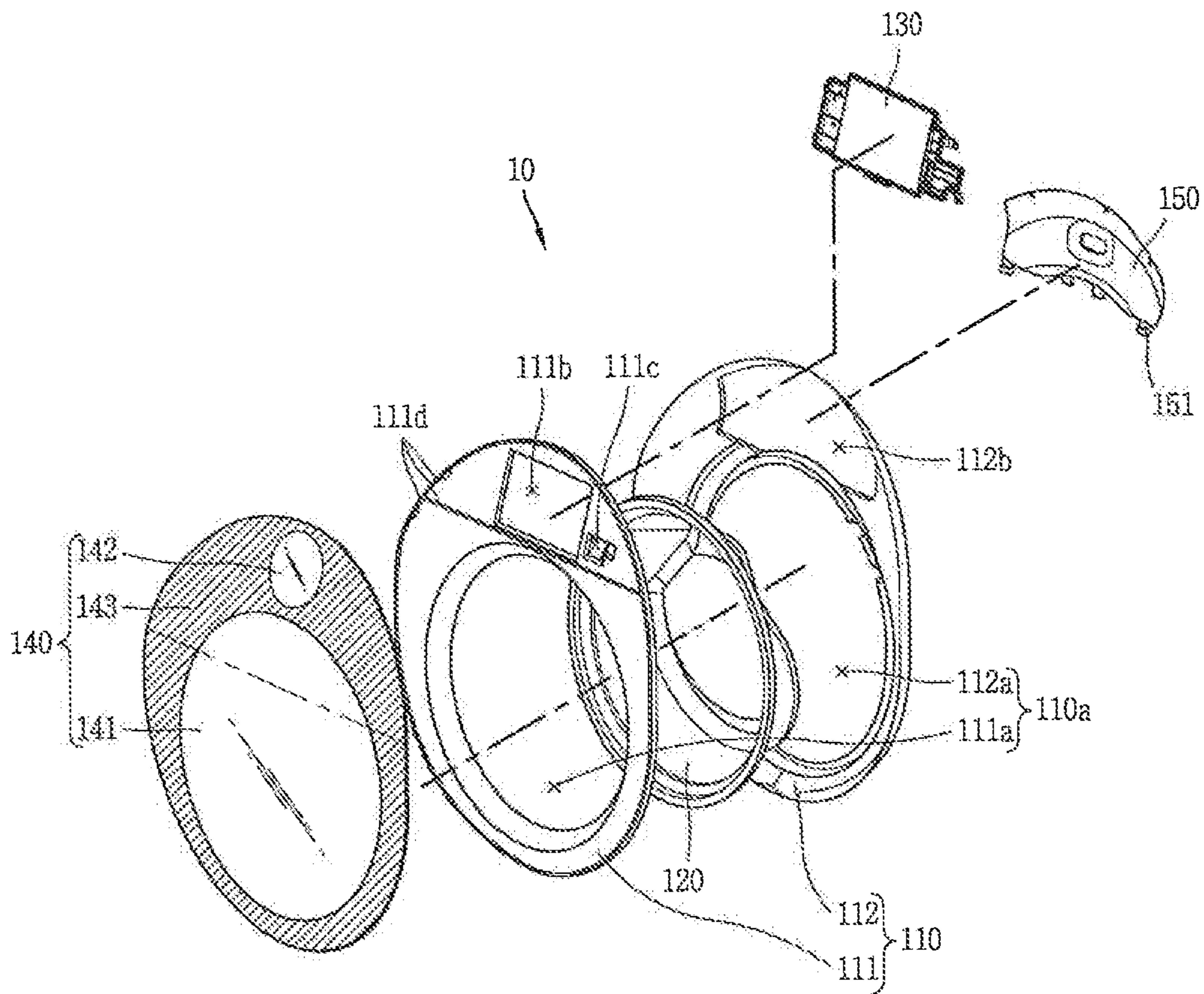

FIG. 4

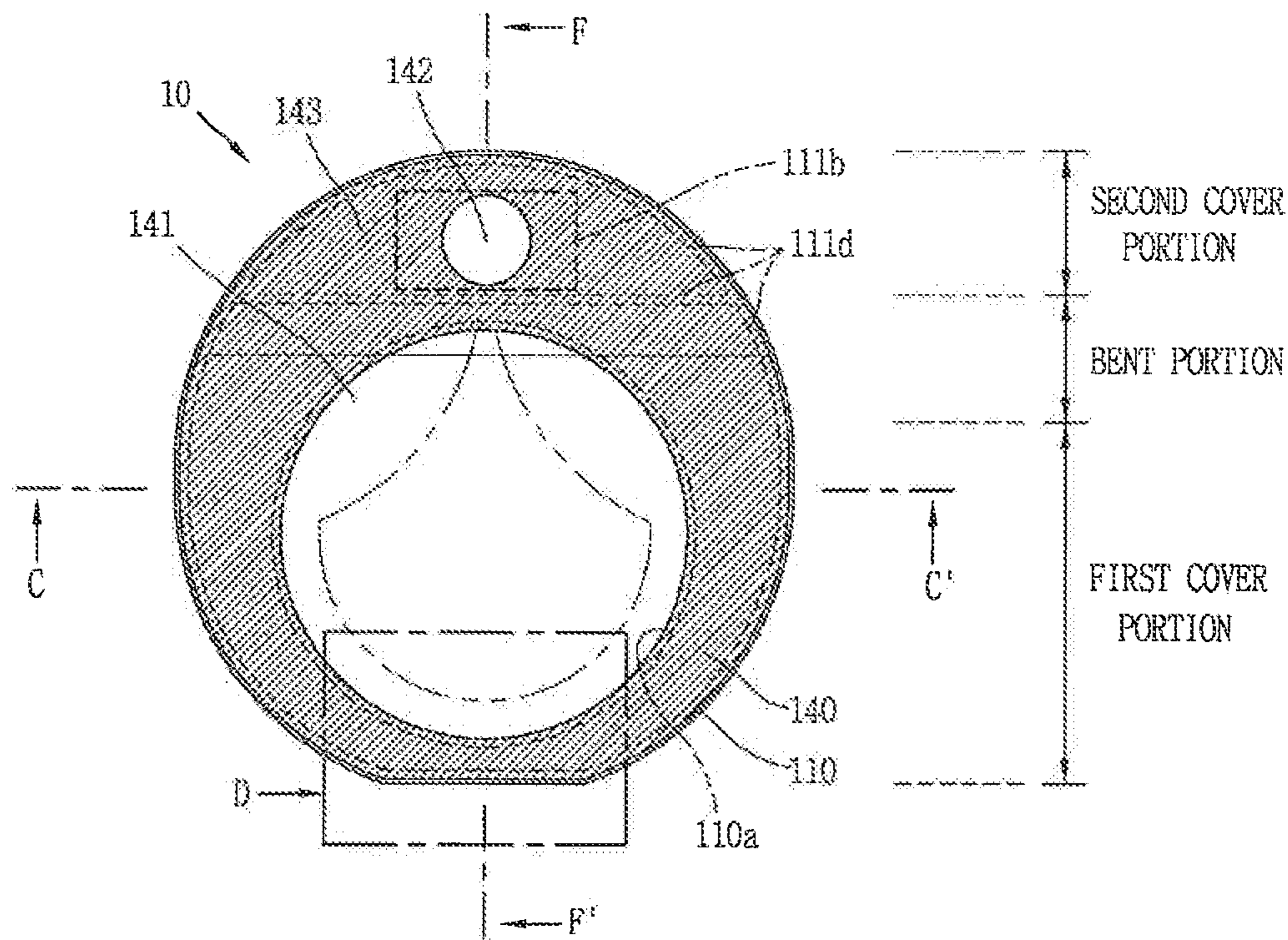

FIG. 5

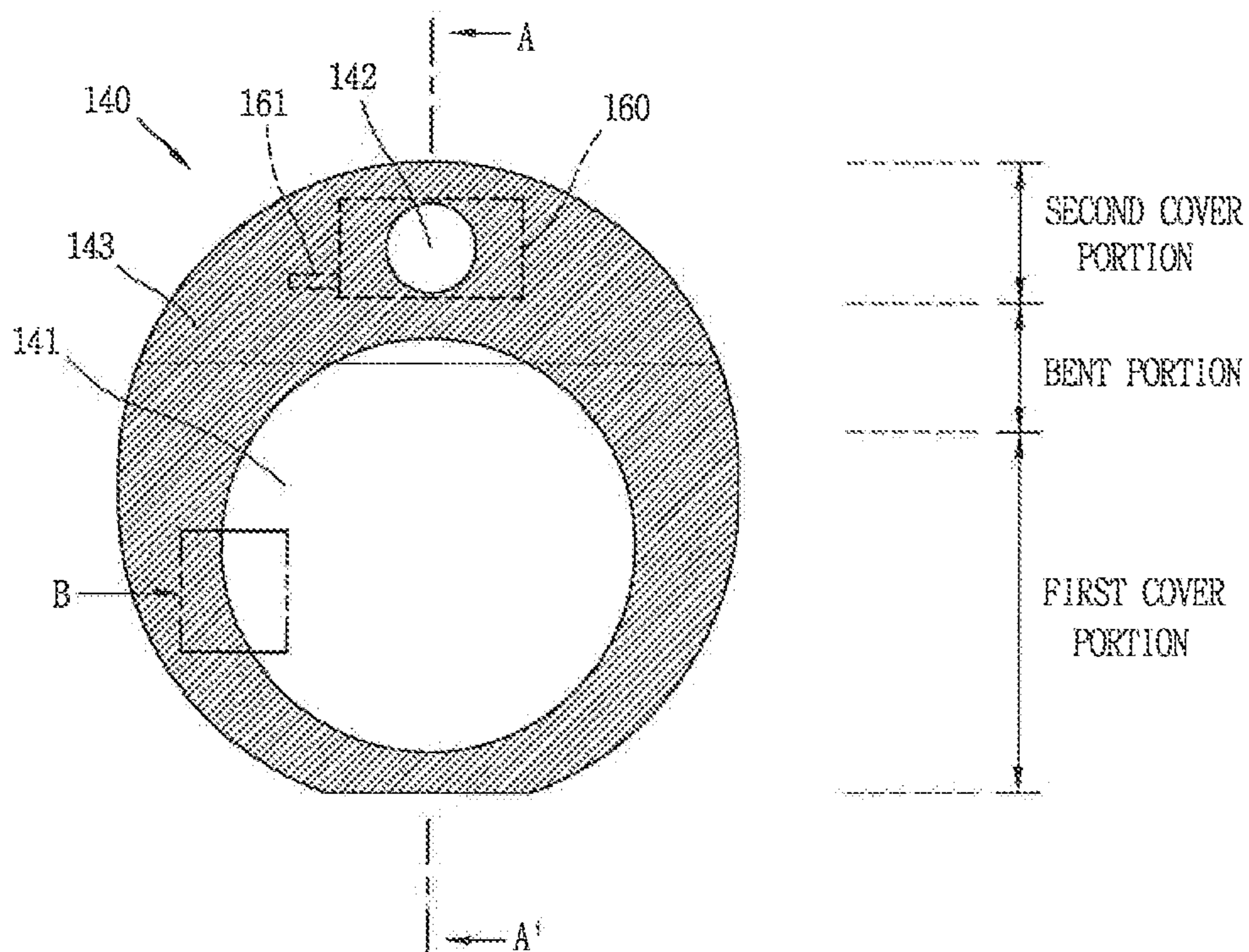

FIG. 6

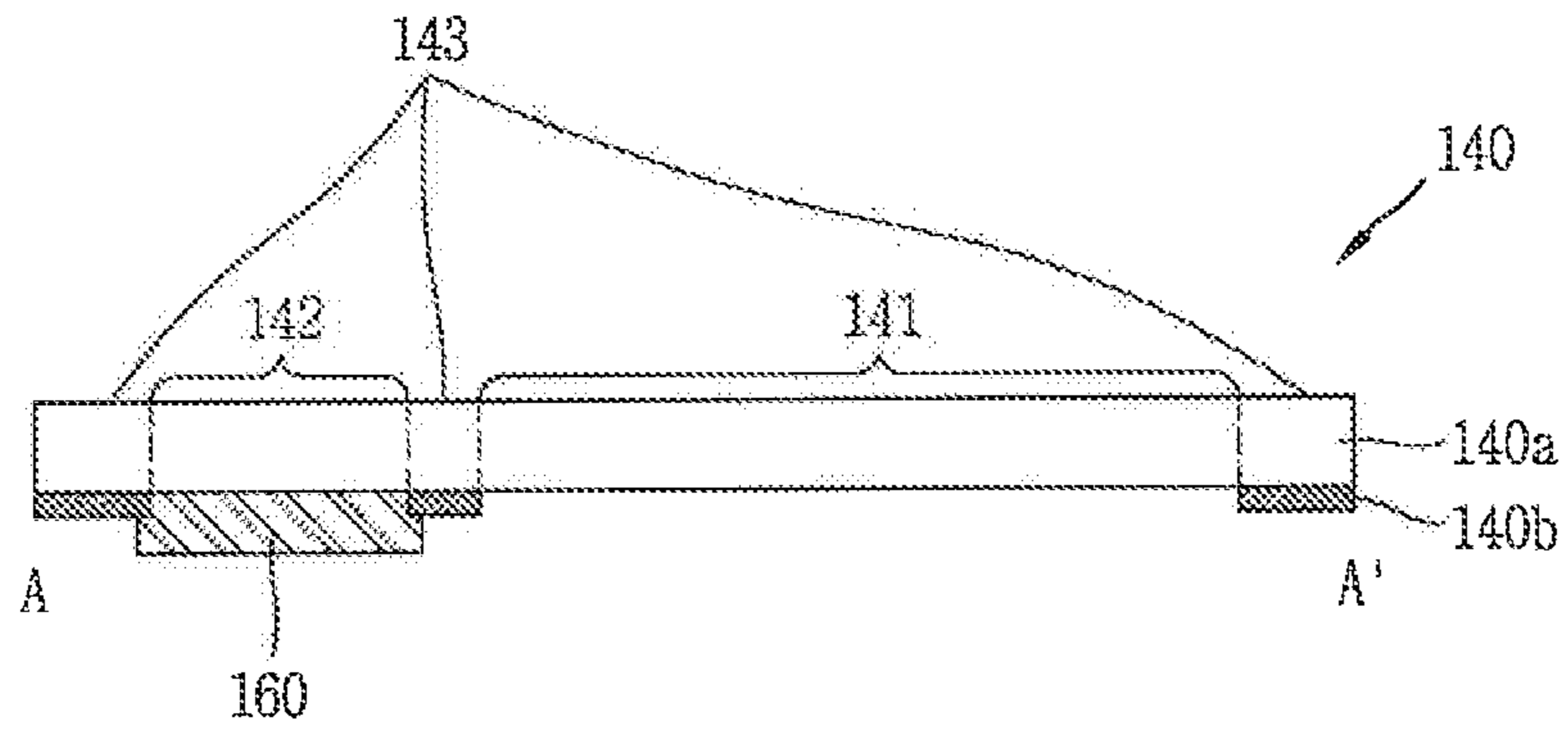

FIG. 7

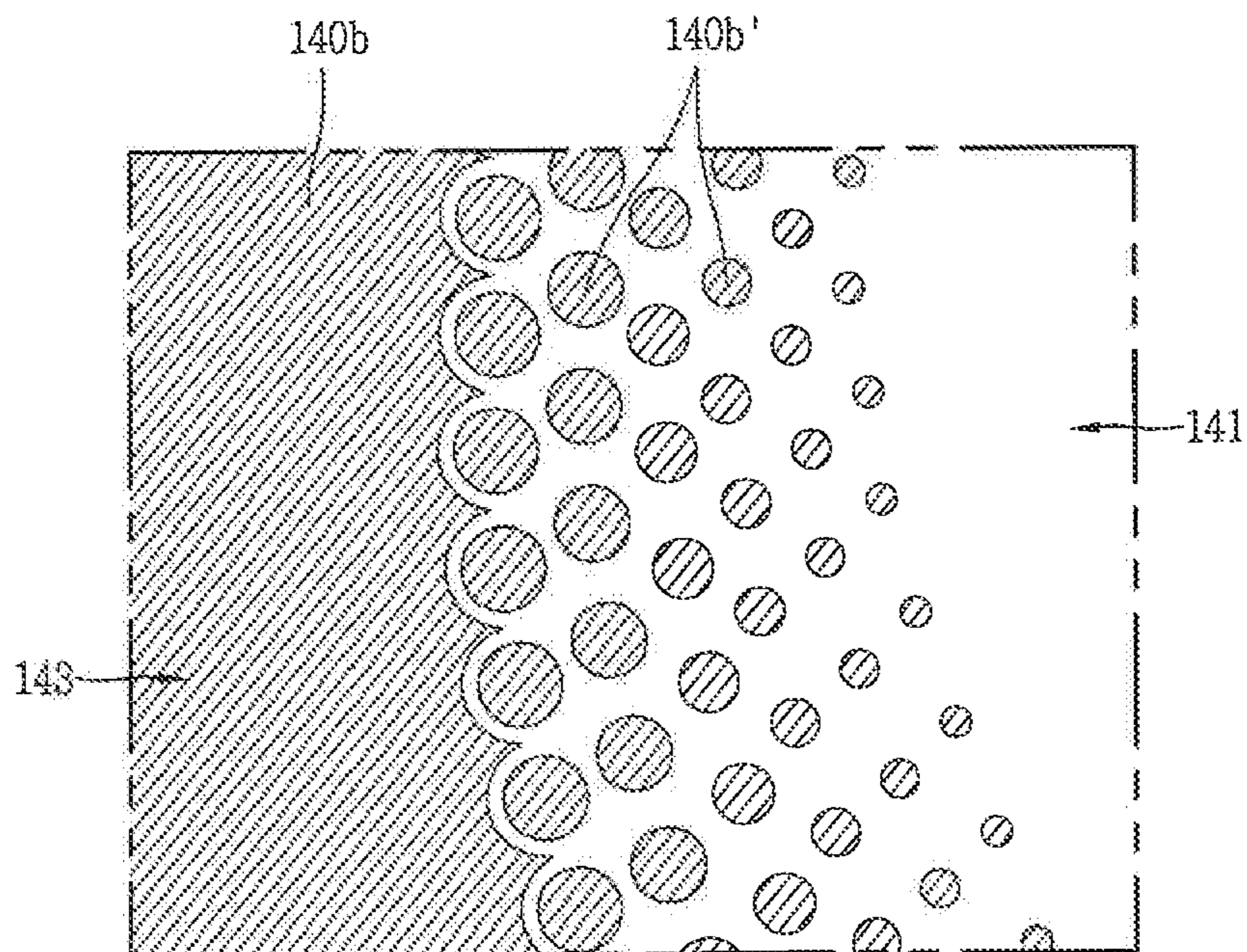

FIG. 8

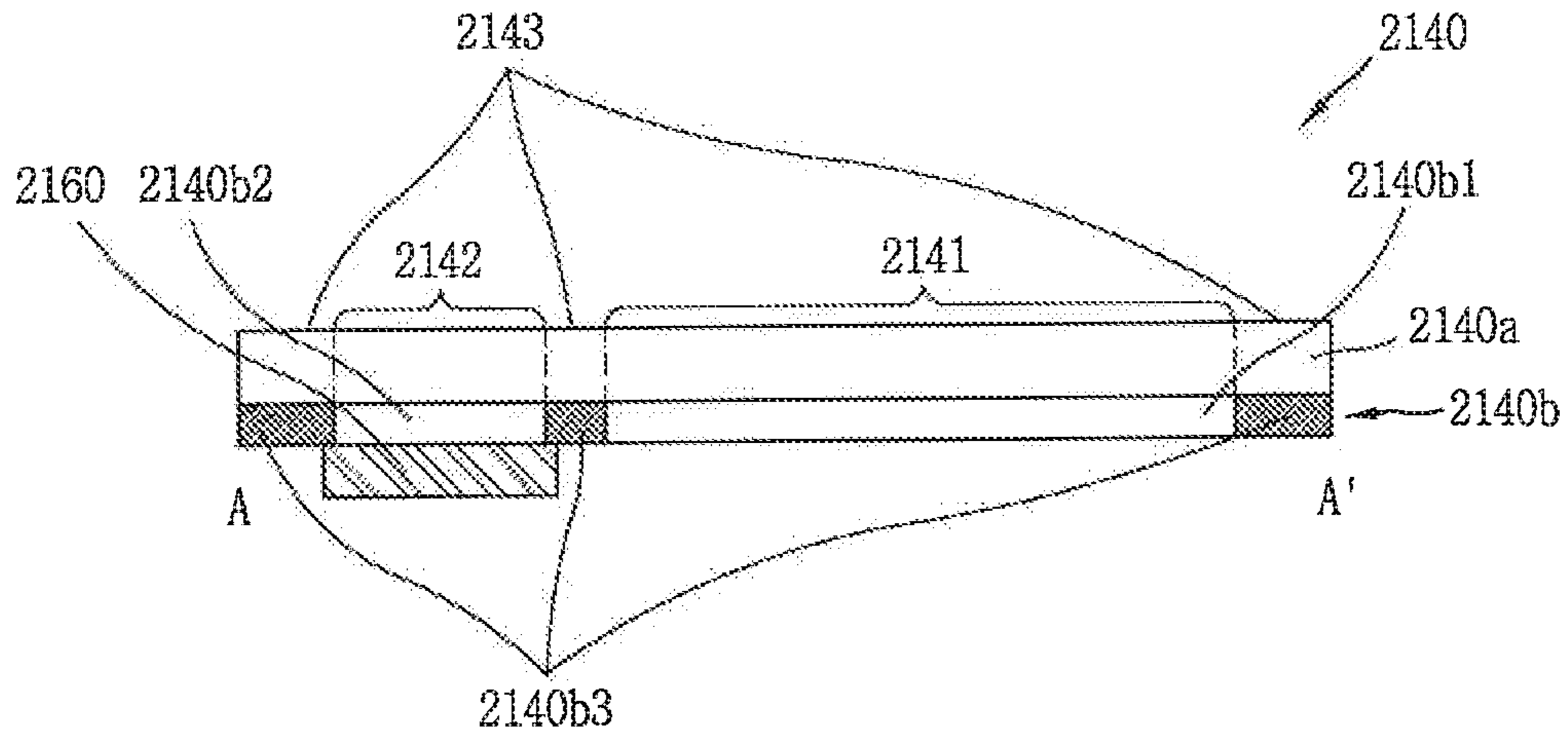

FIG. 9

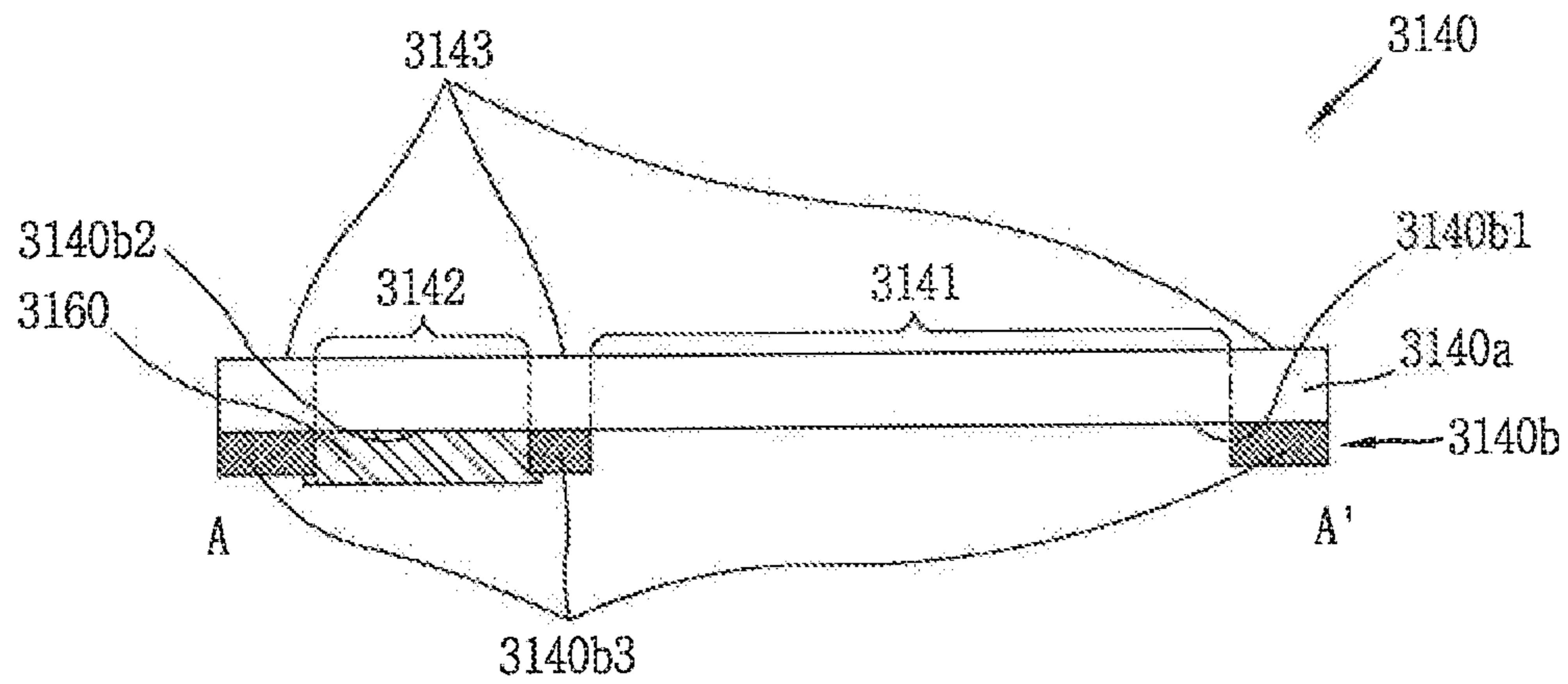

FIG. 10

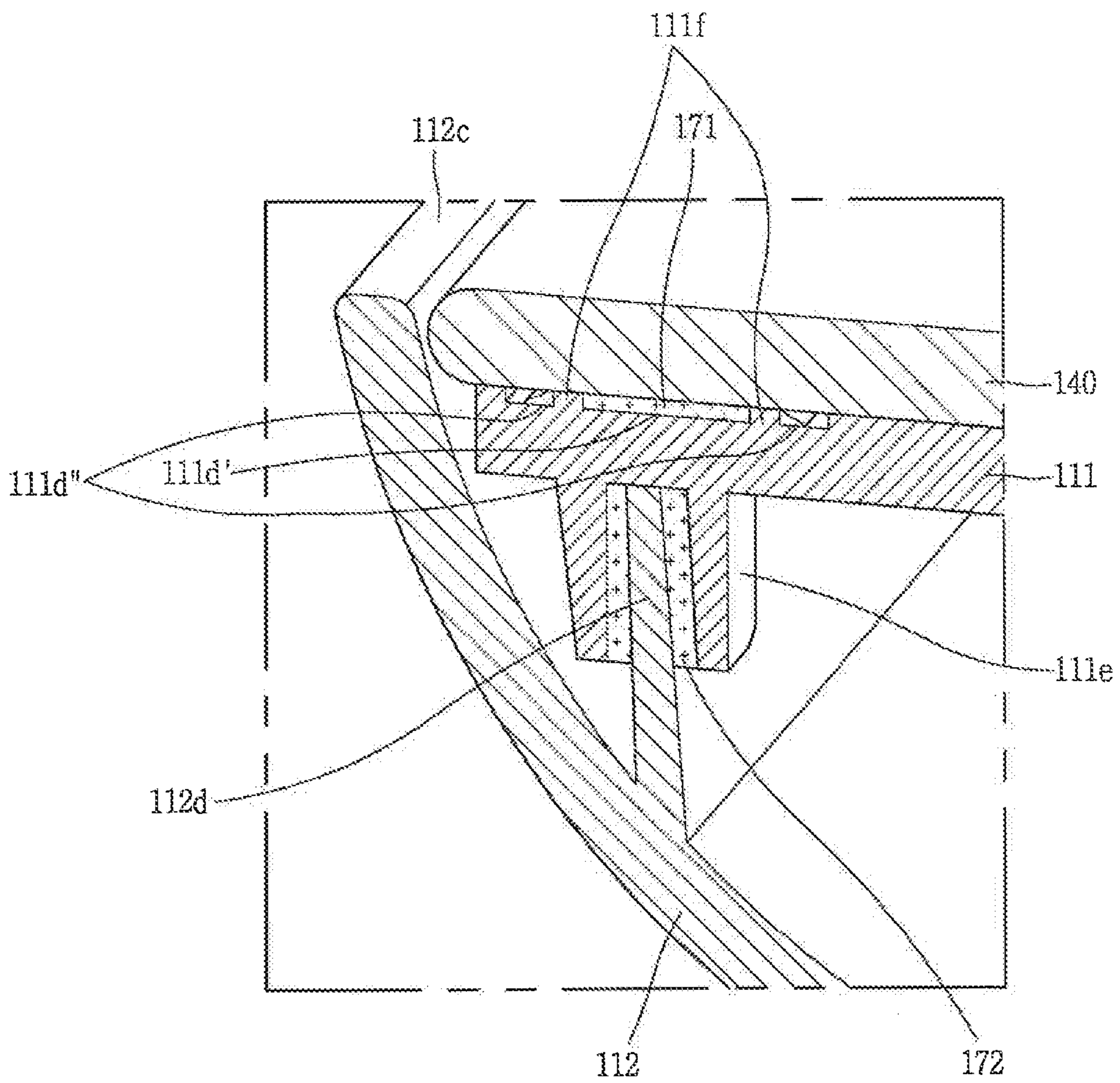

FIG. 11

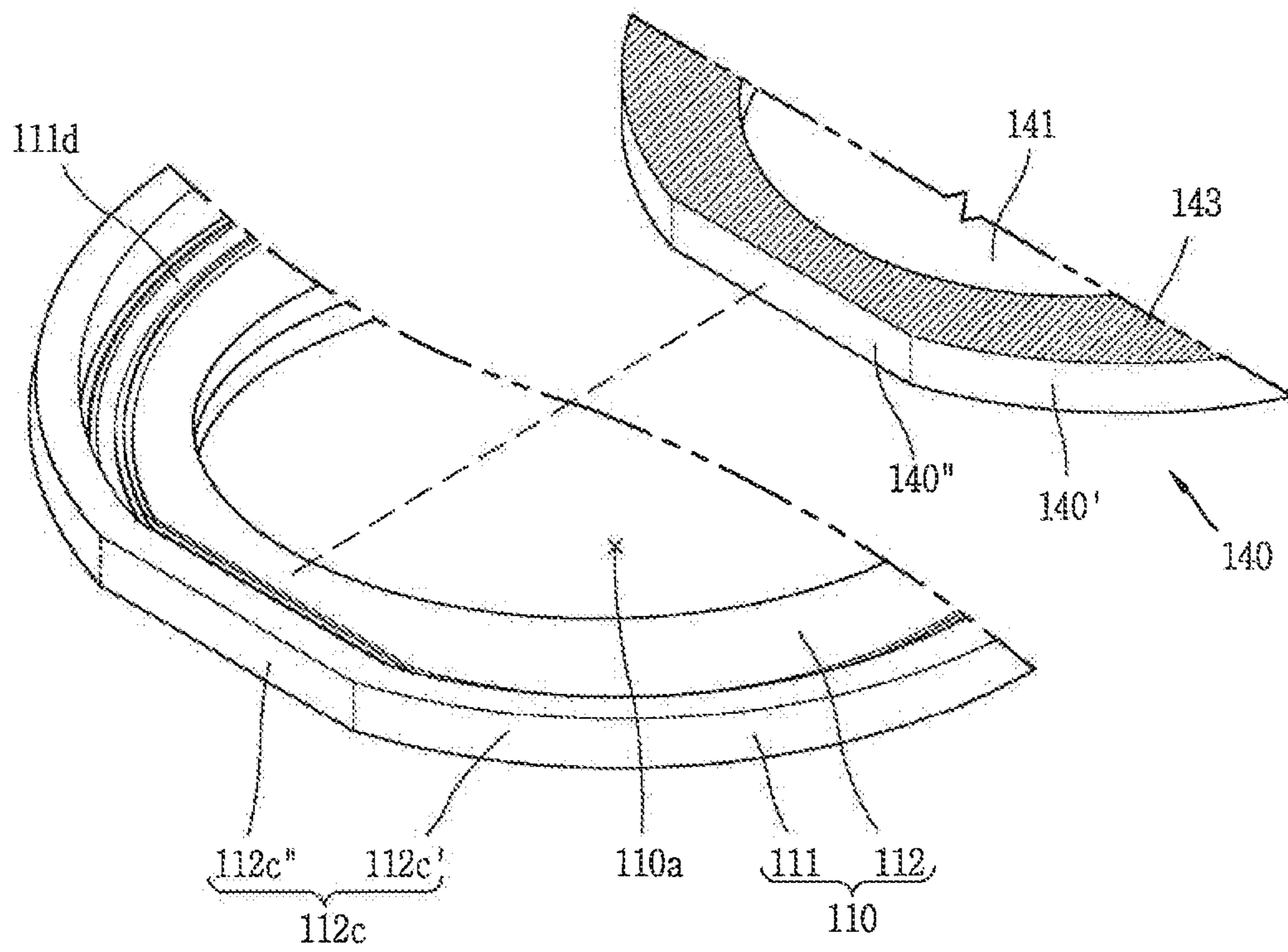

FIG. 12

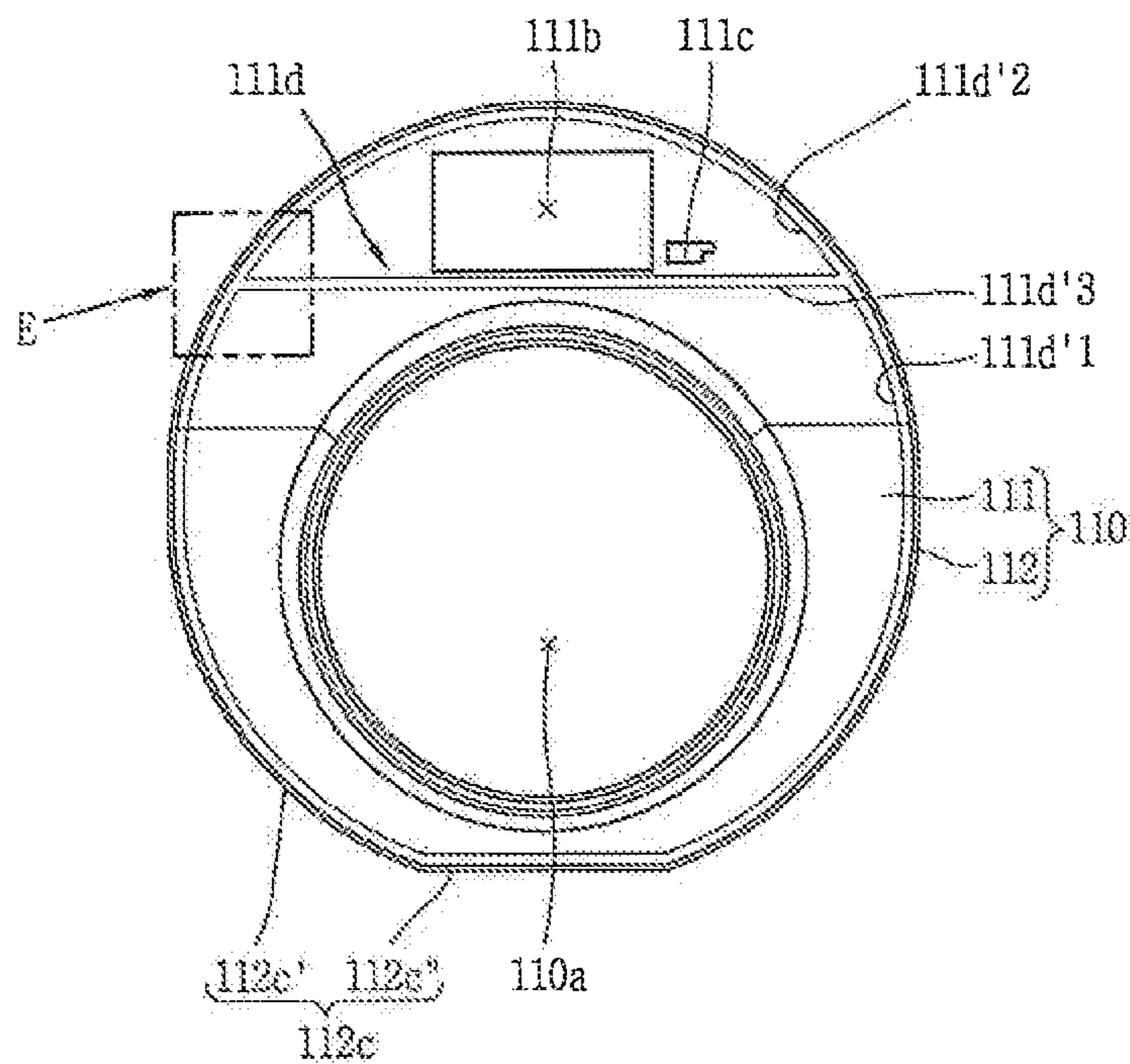

FIG. 13

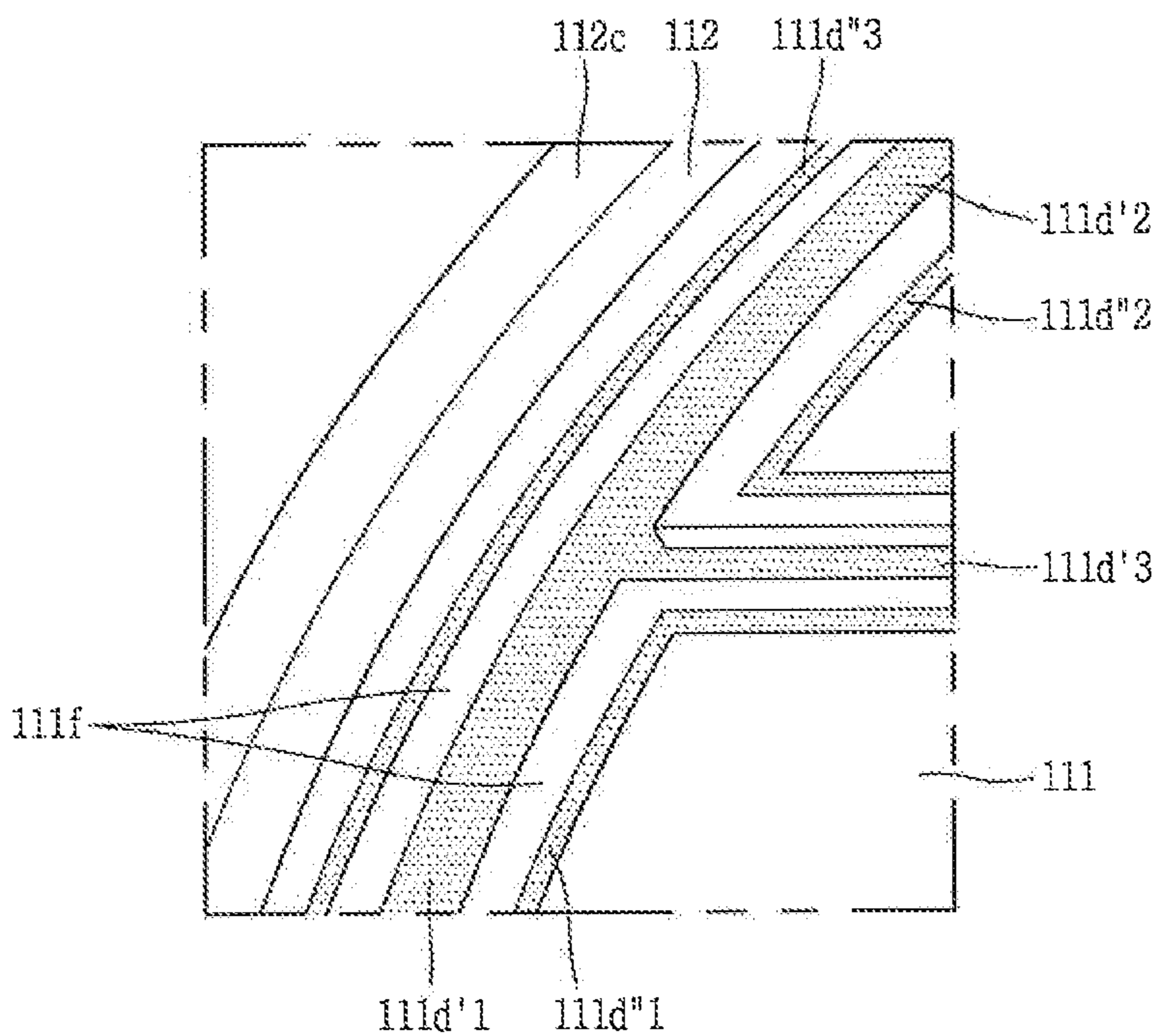

FIG. 14

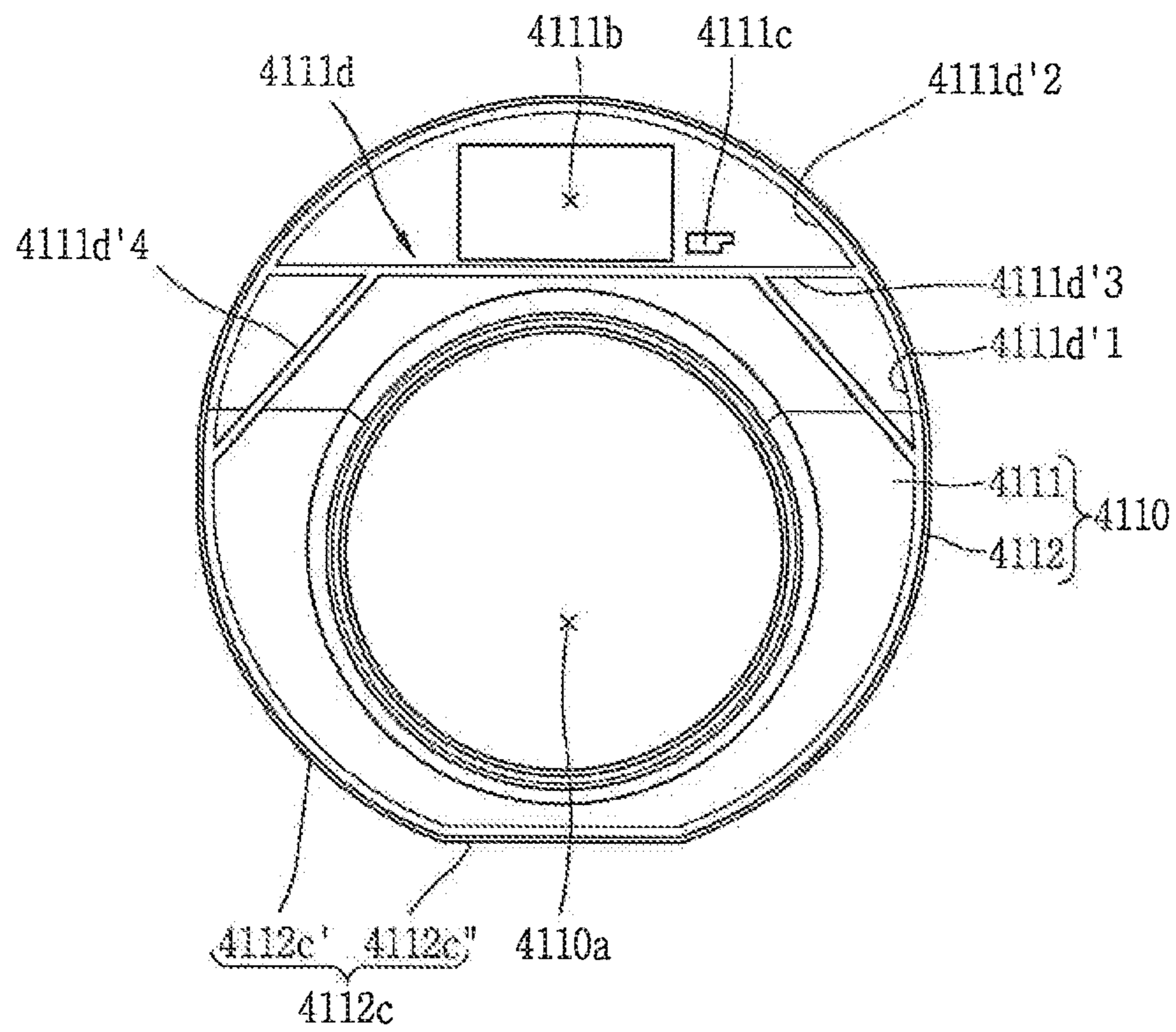

FIG. 15

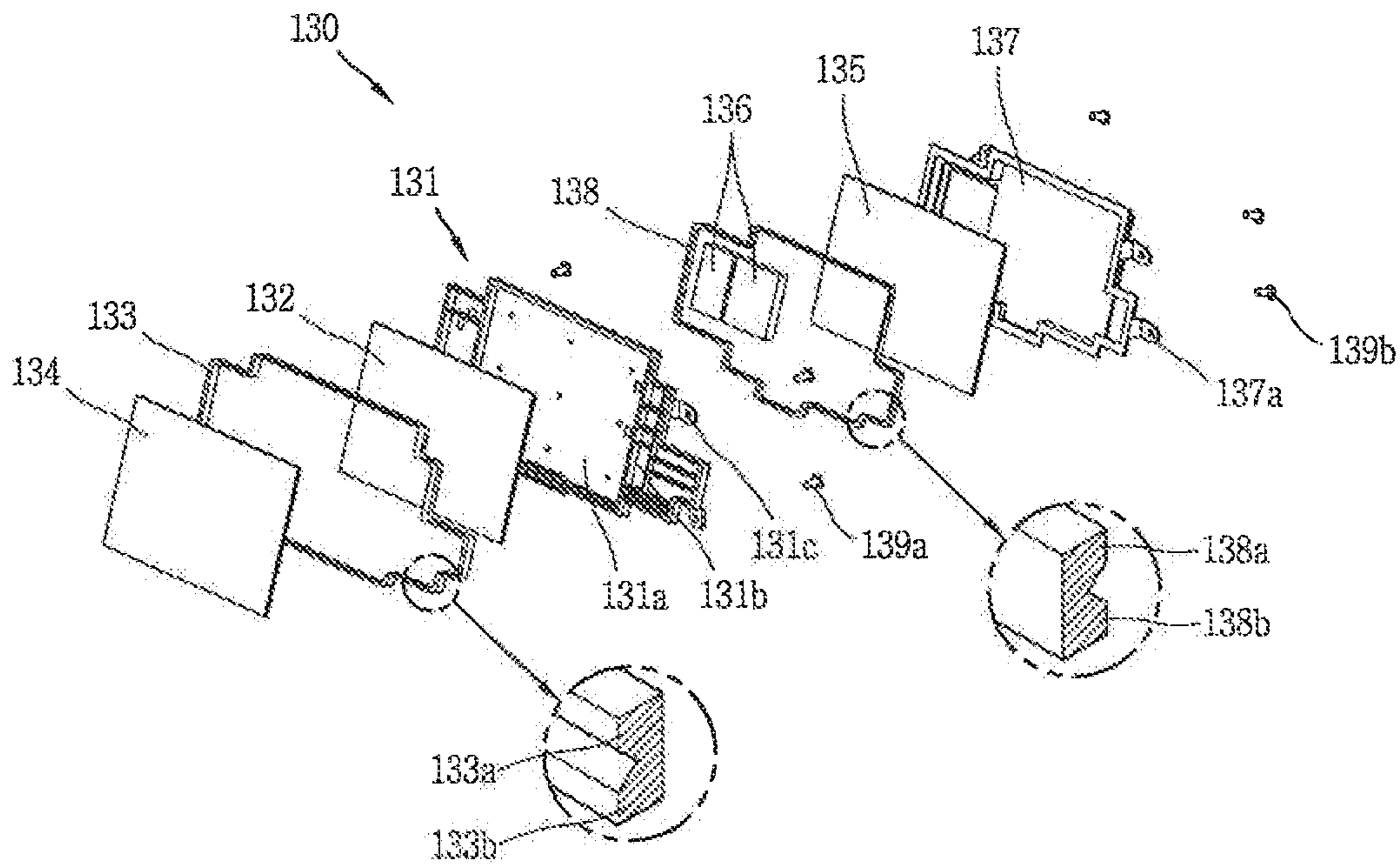

FIG. 16

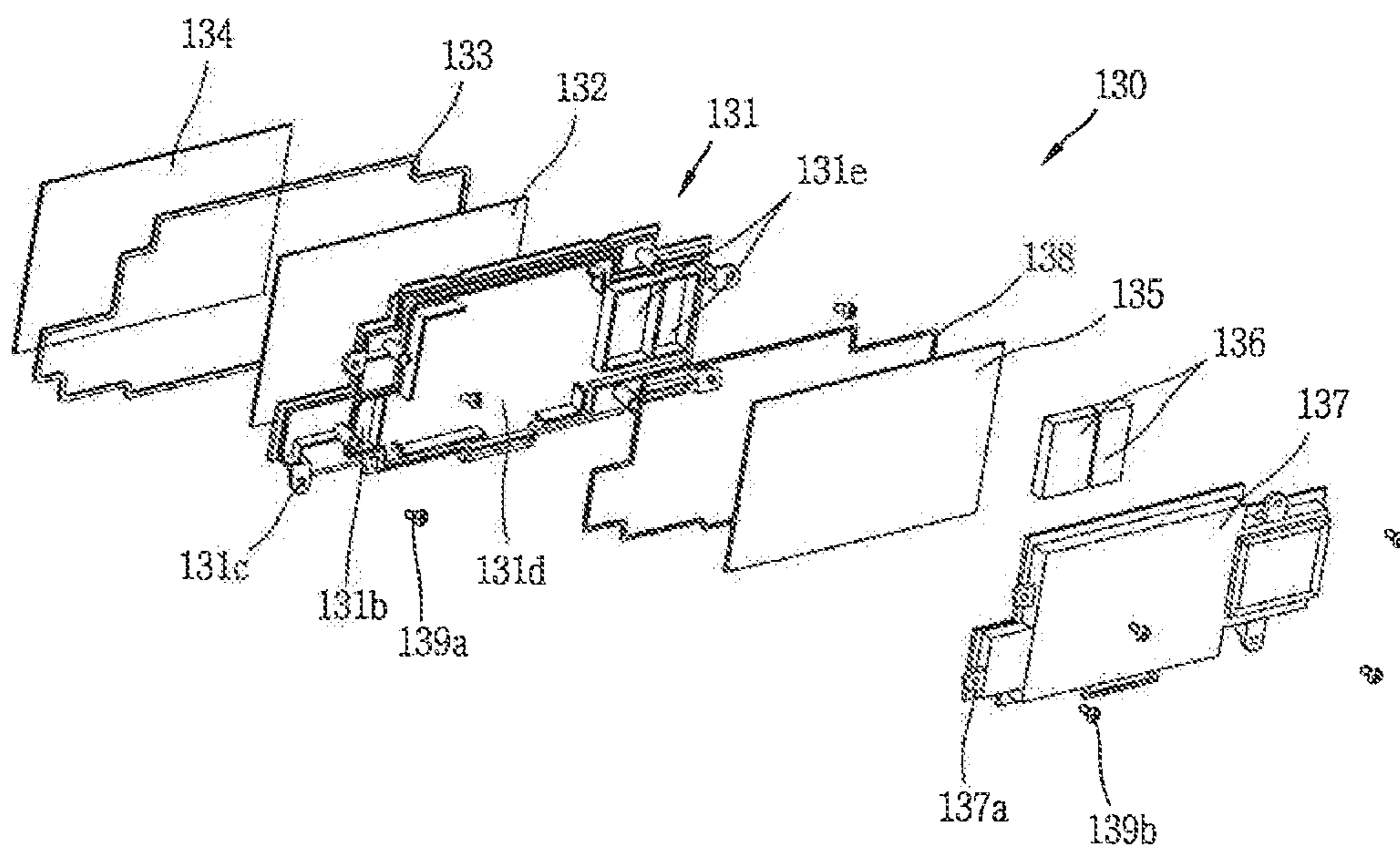

FIG. 17

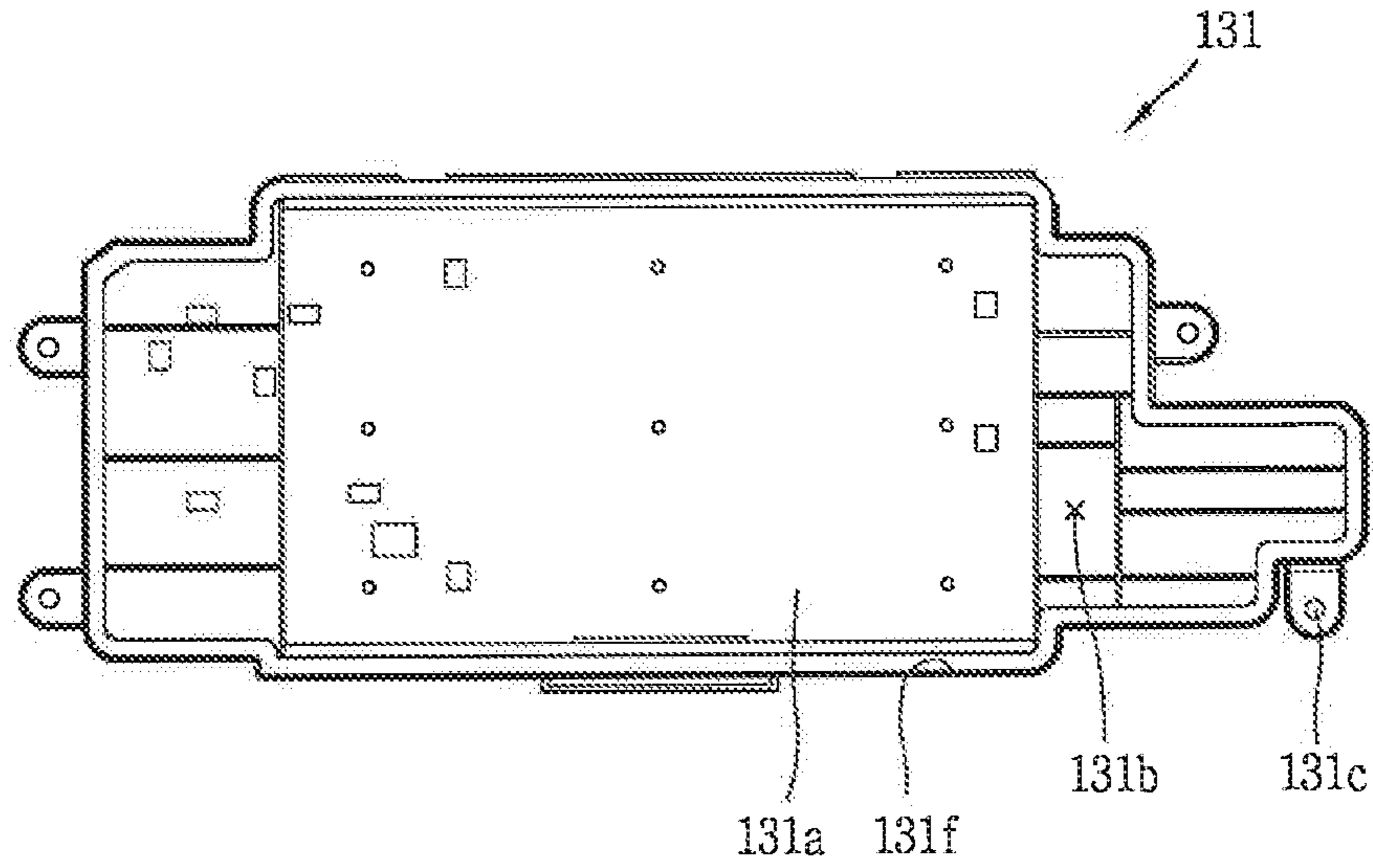

FIG. 18

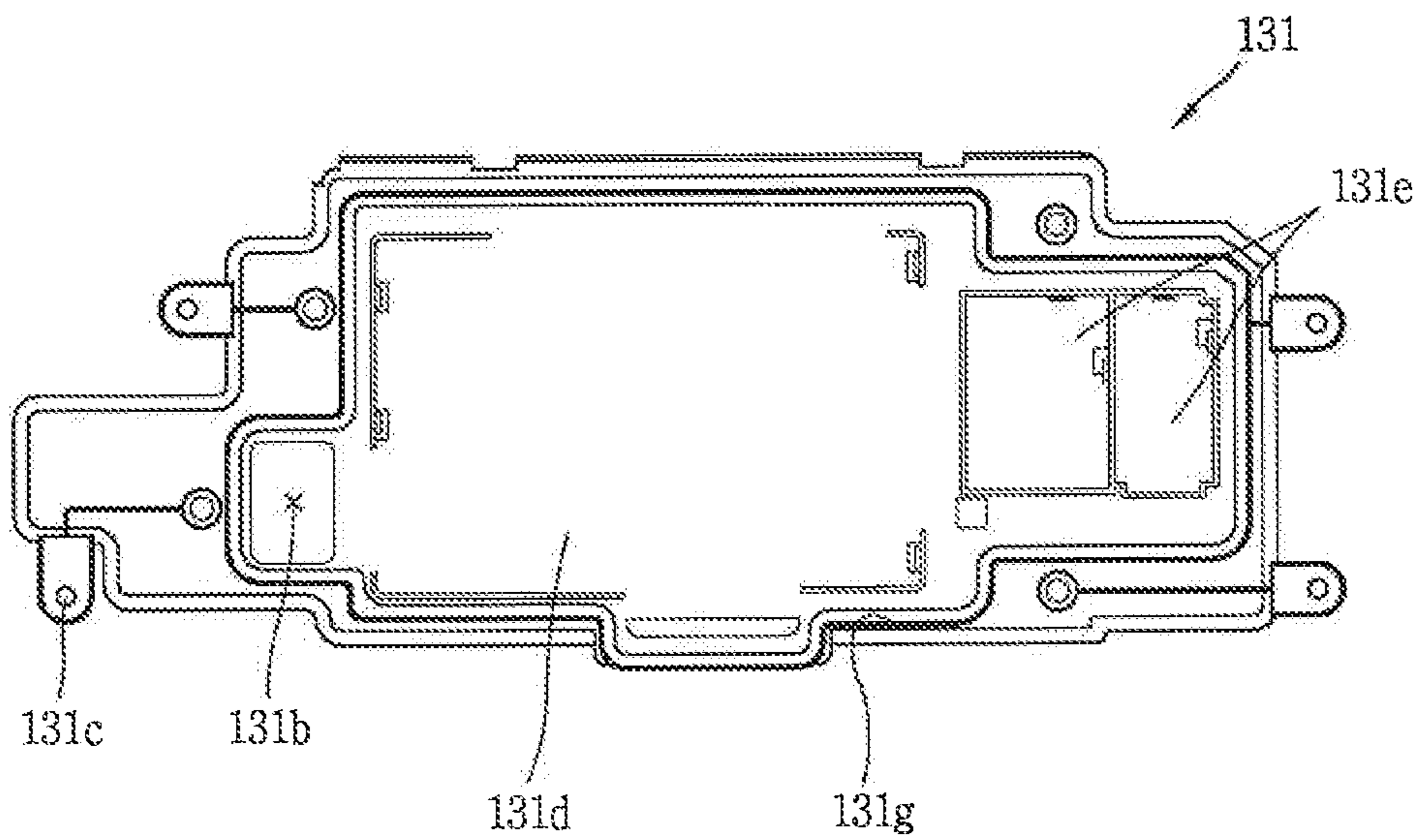

FIG. 19

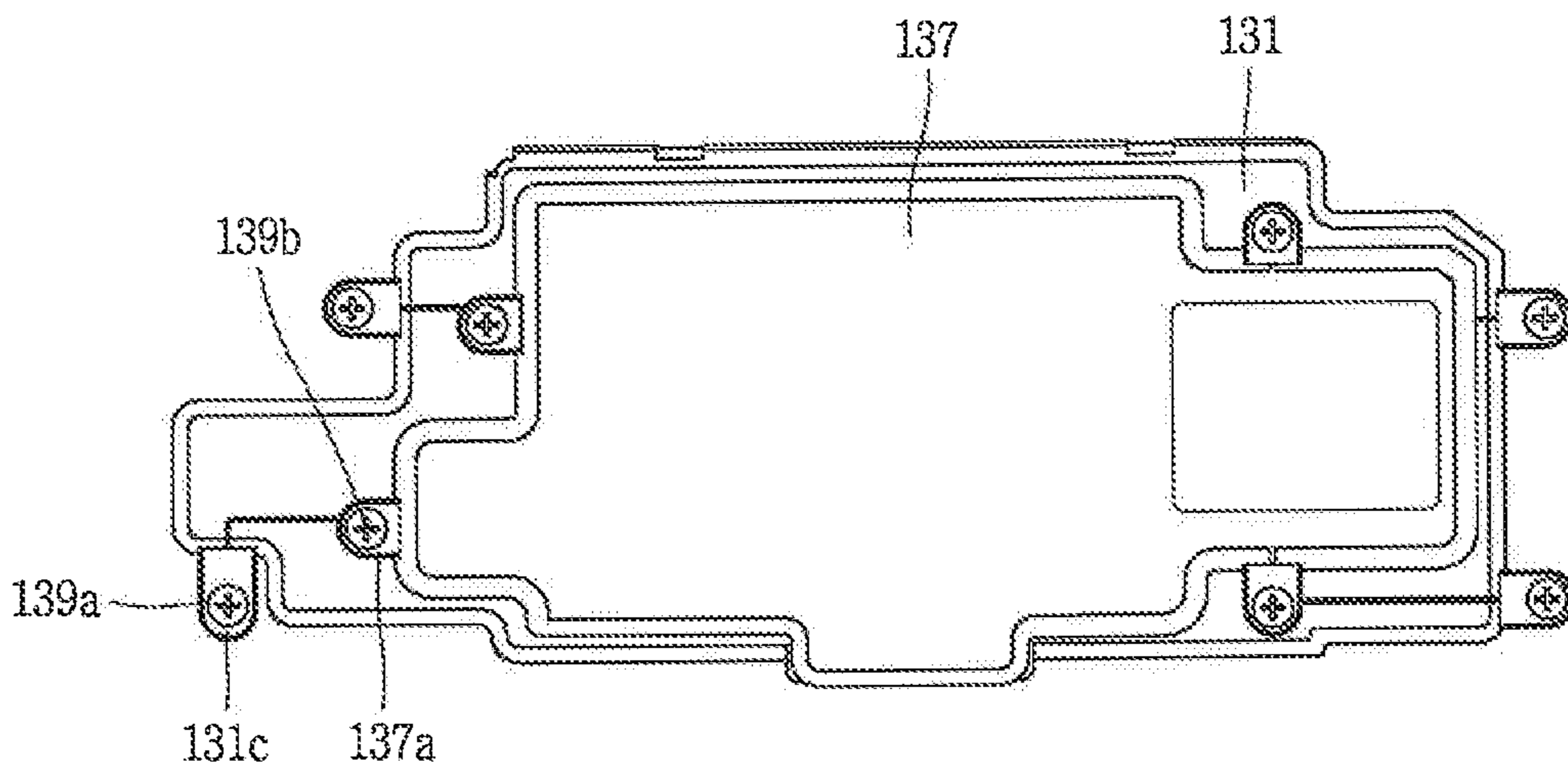

FIG. 20

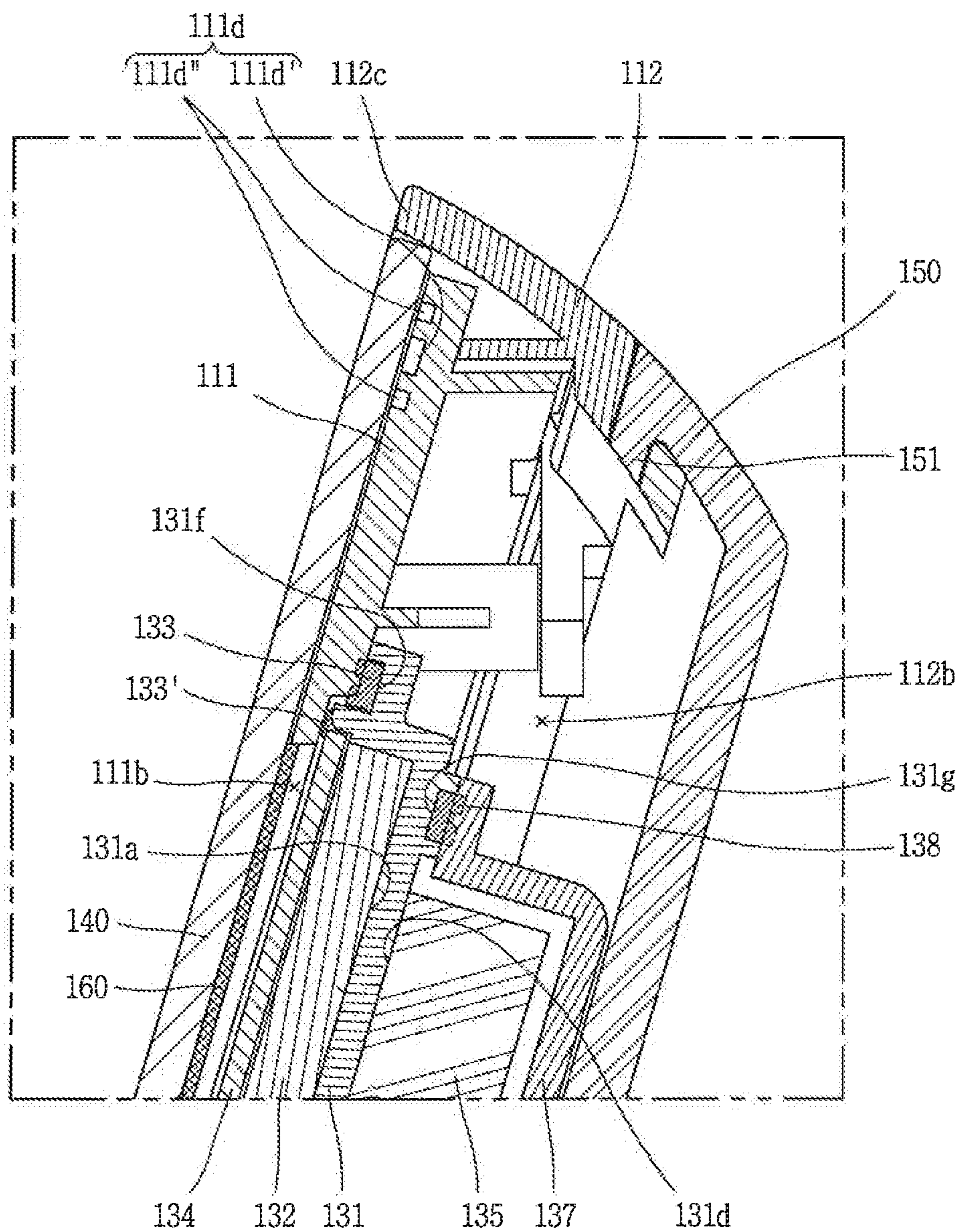

FIG. 21

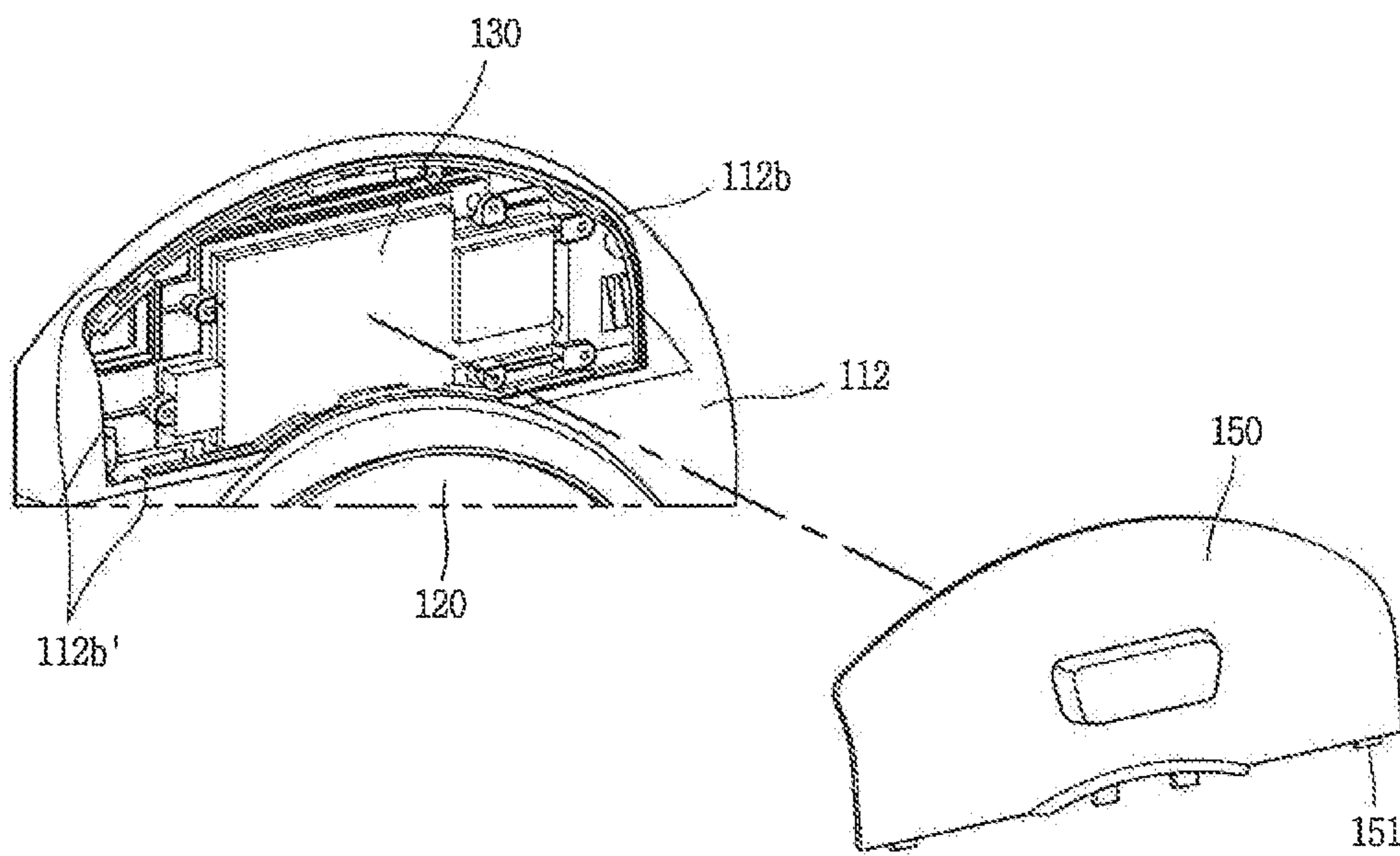

FIG. 22

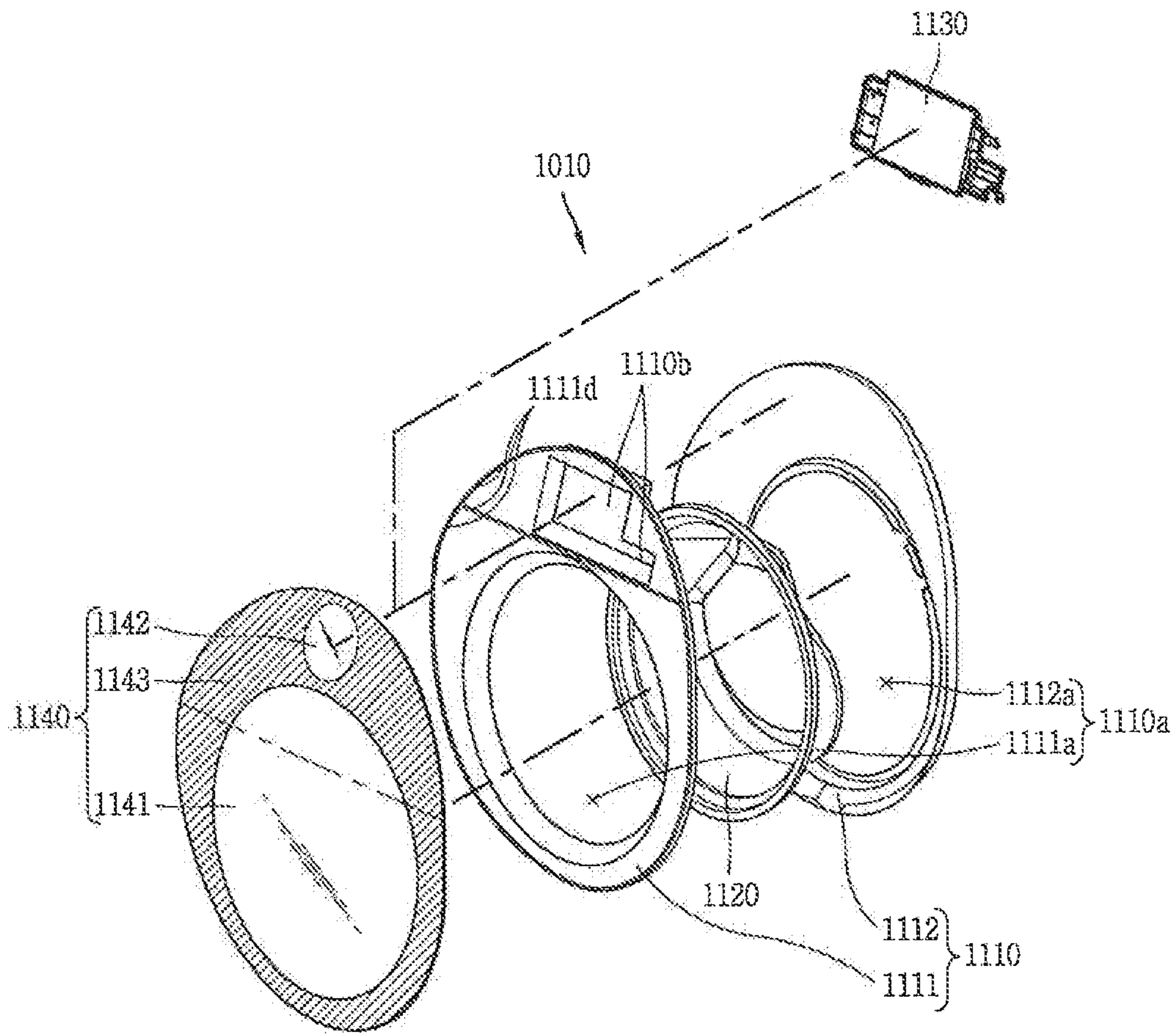

FIG. 23

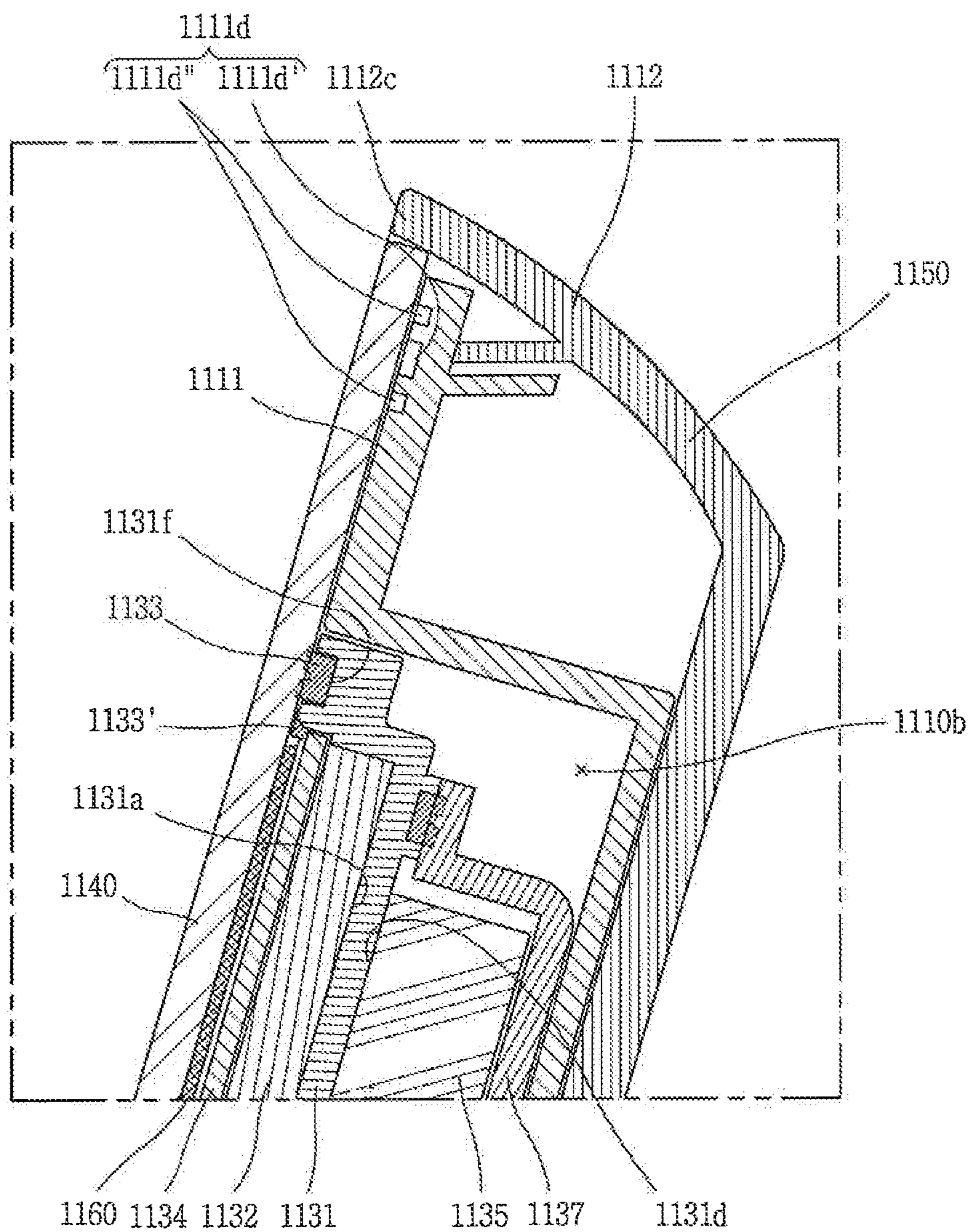

FIG. 24

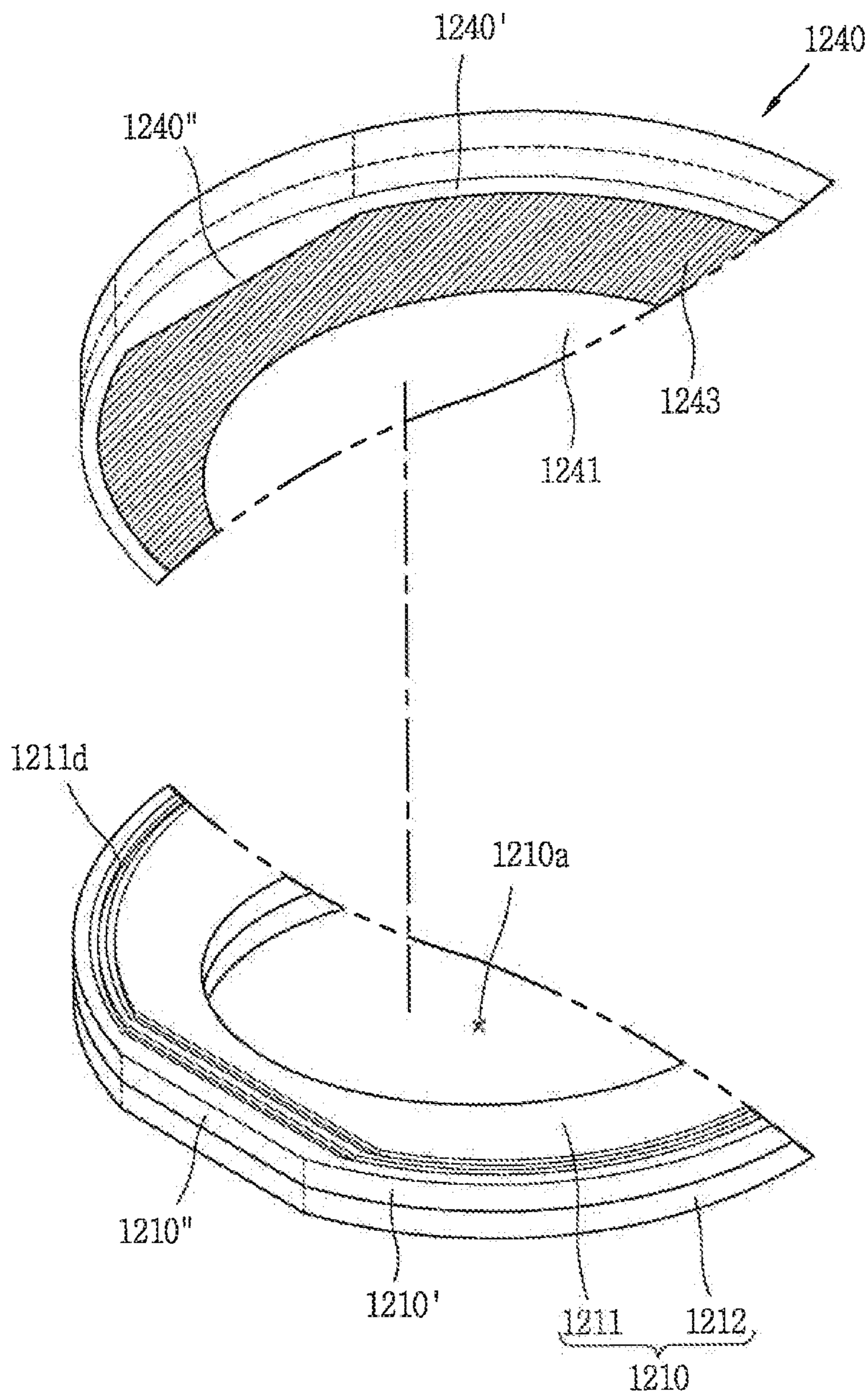

FIG. 25

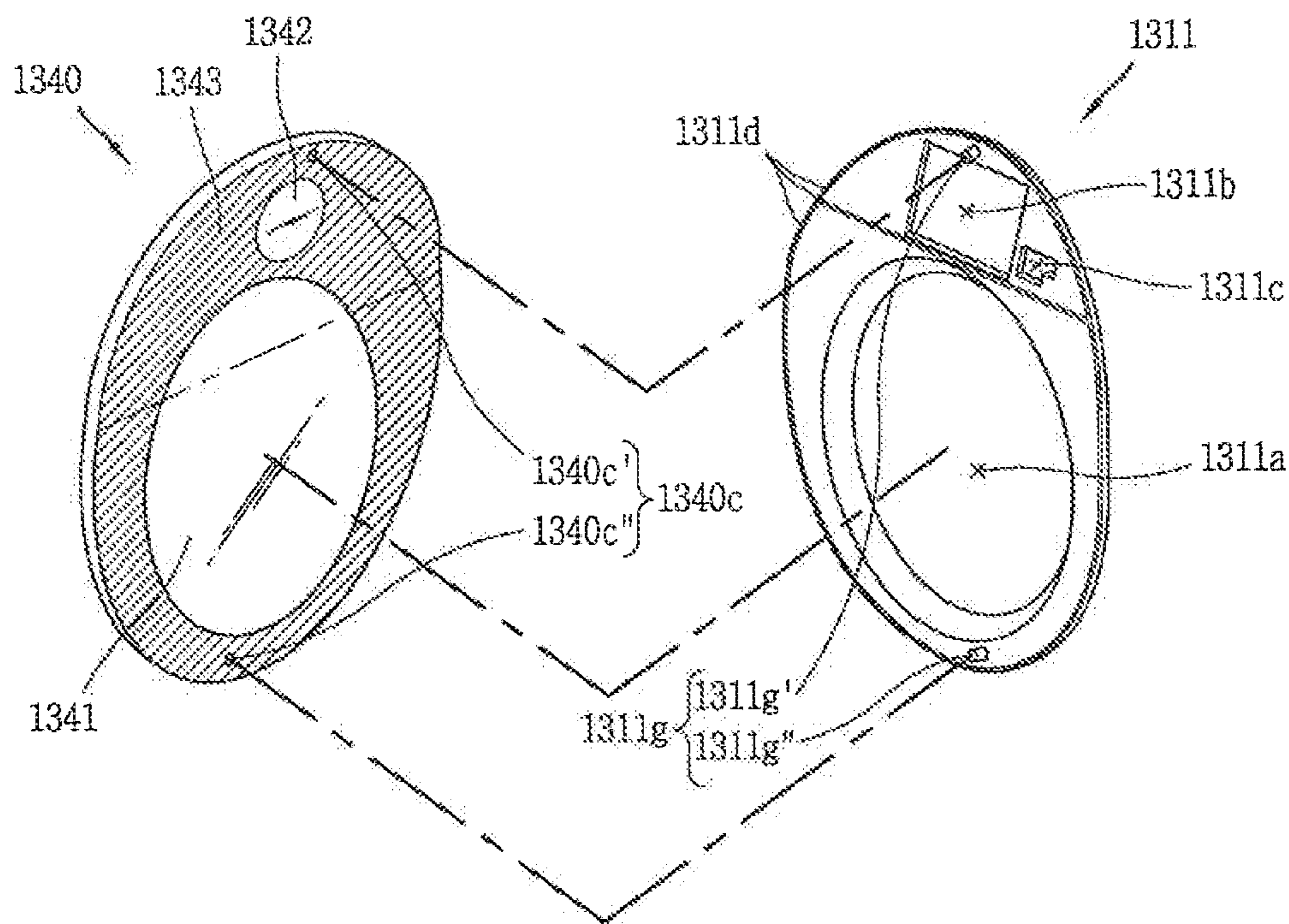
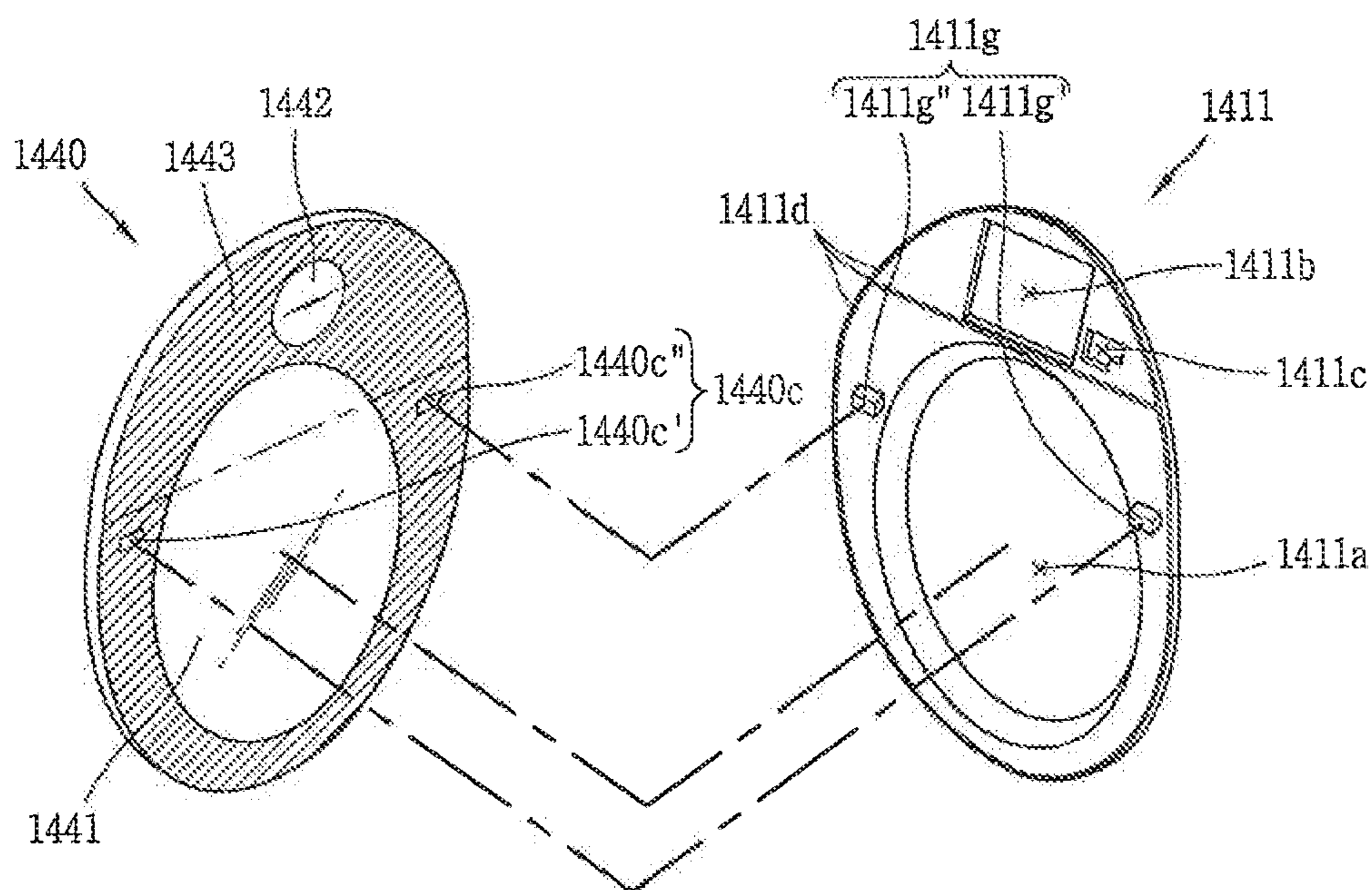

FIG. 26



LAUNDRY TREATING APPARATUS

Matter enclosed in heavy brackets [] appears in the original patent but forms no part of this reissue specification; matter printed in italics indicates the additions made by reissue; a claim printed with strikethrough indicates that the claim was canceled, disclaimed, or held invalid by a prior post-patent action or proceeding.

CROSS-REFERENCE TO RELATED APPLICATION(S)

[Pursuant to] *This application is a Continuation Reissue of Reissue application Ser. No. 16/839,431 filed Apr. 3, 2020 and now issued as U.S. Pat. No. RE49,269, which is a Reissue of U.S. Pat. No. 10,006,159, filed on Oct. 28, 2016 and issued on Jun. 26, 2018, which claims priority under 35 U.S.C. § 119(a), this application claims the benefit of the earlier filing date and the right of priority* 119 to U.S. Provisional Application No. 62/249,355, filed on Nov. 2, 2015, Korean Application No. 10-2016-0001215, filed on Jan. 5, 2016, and Korean Application No. 10-2016-0040448, filed on Apr. 1, 2016, the contents of which [is] are incorporated by reference herein in its entirety. *More than one reissue application has been filed for the reissue of U.S. Pat. No. 10,006,159. The reissue application numbers are U.S. Patent application Ser. No. 16/839,431 (filed on Apr. 3, 2020 and now issued as U.S. Pat. No. RE49,269); U.S. patent application Ser. No. 17/863,637 (filed on Jul. 13, 2022); U.S. patent application Ser. No. 17/863,670 (filed on Jul. 13, 2022); U.S. Patent application Ser. No. 17/863,687 (filed on Jul. 13, 2022); U.S. patent application Ser. No. 17/863,718 (the present application, filed on Jul. 13, 2022); U.S. patent application Ser. No. 17/863,746 (filed on Jul. 13, 2022); and U.S. patent application Ser. No. 17/863,774 (filed on Jul. 13, 2022).*

BACKGROUND

1. Field

The present disclosure relates to a laundry treating apparatus having a door for opening and closing a laundry inlet of a body.

2. Background

A laundry treating apparatus may include an apparatus for washing laundry, an apparatus for drying laundry, and an apparatus capable of performing washing and drying operations at the same time. In a laundry treating apparatus, the washing of laundry may be a cycle of removing contaminants adhered to the laundry through the action of water and detergent, and the drying of laundry may be a cycle of removing moisture contained in the laundry through a hot air supply device provided in the laundry treating apparatus.

A typical laundry treating apparatus may include a body configured to form an appearance thereof and provided with a laundry inlet, a laundry accommodation portion or space provided within the body, a drive unit (or drive) configured to rotate a drum constituting the laundry accommodation portion, a door configured to open and close the laundry inlet, and a control unit (or controller) configured to display visual information associated with a cycle treated on the laundry treating apparatus for a user and receive the user's input.

Such a typical laundry treating apparatus has been designed to perform an inherent function capable of opening and closing the laundry inlet and viewing the laundry

accommodation portion. Furthermore, the control unit may typically be provided on the body, and provided with a plurality of buttons or knobs to briefly display only predetermined cycles in an on/off manner or the like, and manipulating them.

The differentiation between a door and a control unit has been a hindrance to the simple appearance of the laundry treating apparatus, and input and output interfaces between the laundry treating apparatus and the user have been more likely to stay in a low-level manner.

As a result, studies for placing the control unit on a door, and implementing the control unit with a touch screen have been carried out. The related technologies can be also found in the Korean Patent Publication Nos. 10-2011-0130089 (published on Dec. 5, 2011) and 10-2015-0006264 (published on Jan. 16, 2015) whose disclosures are hereby incorporated by references in their entirety. However, studies on an integrated aesthetic sense for the door and touch screen as well as on a door structure capable of arousing advanced sensibility at low cost are still not entirely satisfactory.

In order to couple a door cover to a door frame, an adhesive is typically used along with a mechanical fastening structure using a bracket, a hook or the like. However, when a door cover with a glass material is used to give a high-quality feeling, it may be difficult to use such a mechanical fastening structure. Moreover, when the door cover is formed in a circular shape, it may be difficult to align a correct installation position for the door frame.

Furthermore, the adhesive may be leaked during the process of coupling a door cover to a door frame through the adhesive, thereby causing the deterioration of appearance quality. In order to prevent the problem, the adhesive may be coated at an inner side of the door frame located far away from an edge portion thereof, which may result in the deterioration of the joint strength, and have a problem of causing foreign substances to easily be infiltrated through a gap between the door cover and the door frame.

When the door has a configuration of opening and closing a laundry inlet, when a touch screen is provided on the door, moisture may likely leak into electronic elements constituting the touch screen. Accordingly, the sealing of the electronic elements may be a key point in the aspect of securing the reliability of driving the touch screen.

BRIEF DESCRIPTION OF THE DRAWINGS

Embodiments will be described in detail with reference to the following drawings in which like reference numerals refer to like elements, and wherein:

FIG. 1 is a perspective view illustrating a laundry treating apparatus according to an embodiment;

FIG. 2A is a conceptual view illustrating a configuration in which a door illustrated in FIG. 1 is primarily rotated to open a laundry inlet;

FIG. 2B is a conceptual view illustrating a configuration in which the door is secondarily rotated in the configuration illustrated in FIG. 2A;

FIG. 3 is an exploded perspective view of the door illustrated in FIG. 1;

FIG. 4 is a front view of the door illustrated in FIG. 1;

FIG. 5 is a rear view of a door cover illustrated in FIG. 3;

FIG. 6 is a cross-sectional view illustrating a first embodiment of the door cover taken along line A-A' illustrated in FIG. 5;

FIG. 7 is an enlarged view of a portion "B" illustrated in FIG. 5;

3

FIG. 8 is a cross-sectional view illustrating a second embodiment of the door cover taken along line A-A' illustrated in FIG. 5;

FIG. 9 is a cross-sectional view illustrating a third embodiment of the door cover taken along line A-A' illustrated in FIG. 5;

FIG. 10 is a cross-sectional view taken along line C-C' illustrated in FIG. 4;

FIG. 11 is a conceptual view in which the door cover and a door frame are shown in a separate manner on a portion "D" illustrated in FIG. 4;

FIG. 12 is a front view illustrating a first embodiment of the door frame illustrated in FIG. 3;

FIG. 13 is an enlarged view of a portion "E" illustrated in FIG. 12;

FIG. 14 is a front view illustrating a second embodiment of the door frame illustrated in FIG. 3;

FIGS. 15 and 16 are exploded perspective views in which a display module illustrated in FIG. 3 is seen from different directions;

FIG. 17 is a front view of a mounting frame illustrated in FIG. 15;

FIG. 18 is a rear view of the mounting frame illustrated in FIG. 15;

FIG. 19 is a rear view illustrating a configuration in which a PCB cover is coupled to a mounting frame illustrated in FIG. 15;

FIG. 20 is a cross-sectional view taken along line F-F' illustrated in FIG. 4;

FIG. 21 is a conceptual view illustrating a configuration in which a display module illustrated in FIG. 3 is mounted within the door frame;

FIG. 22 is an exploded perspective view of a door according to a modified example of the present disclosure;

FIG. 23 is a cross-sectional view of a door illustrated in FIG. 22; and

FIGS. 24 through 26 are conceptual views illustrating a modified example of a coupling structure between a door cover and a door frame.

DETAILED DESCRIPTION

Referring to the present drawings, a laundry treating apparatus 1 may include a body 20 and a door 10. The body 20 may include a laundry inlet 20a forming an appearance of the laundry treating apparatus 1 to which laundry is input. The laundry inlet 20a may be formed on a front side portion of the body 20 having a hexahedral shape.

A laundry accommodation portion or space into which laundry is accommodated through the laundry inlet 20a may be provided within the body 20. When the laundry treating apparatus 1 is configured as an apparatus for drying laundry, the laundry accommodation portion may be configured with a drum 40 rotatably provided within the body 20. When the laundry treating apparatus 1 is configured as an apparatus capable of washing and drying laundry at the same time, the laundry inlet may be configured with a tub provided within the body 20 to store wash water and a drum 40 rotatably provided within the tub to accommodate laundry.

A drive unit configured to rotate the drum 40 may be provided in the body 20. The drive unit may include a motor configured to generate a driving force and a belt configured to rotate the drum 40 using the driving force.

A detergent supply unit or device may be provided in the body 20 to be pulled out in a withdrawable manner. A cover 21 covering the detergent supply unit may be rotatably configured in a vertical direction.

4

A power button 22 may be provided in the body 20 to turn on or off the power of the laundry treating apparatus 1. When a display 12 which will be described later is configured with a touch screen, the display 12 may be configured to turn on or off the power of the laundry treating apparatus 1 through a touch input to the touch screen. In this case, the power button 22 may not be provided to implement a simpler appearance.

The door 10 may be relatively rotatable with respect to the body 20 to open or close the laundry inlet 20a. The door 10 may be provided to rotate with respect to body 20 by a hinge unit (or hinge) 30.

The body 20 may include a door accommodation portion or space 20b recessed in an inward direction on an outer surface of the body 20 to have the laundry inlet 20a therewithin. When the door 10 is closed, the door 10 may be accommodated into the door accommodation portion 20b, and an edge portion of the outer surface of the door cover may be aligned on the same plane as an outer surface of the body 20 adjacent thereto.

In order to ensure that the door 10 does not interfere with the body 20 when the door 10 is opened as described above, the hinge unit 30 may have a double hinge structure having two different rotating shafts. As illustrated in FIGS. 2A and 2B, the hinge unit 30 may be configured such that the door 10 is separated from the door accommodation portion 20b by primary rotation about any one rotating shaft, and then the body 20 is rotated by secondary rotation about another rotating shaft.

When the hinge unit 30 is mounted at a first side of the door 10, a locking device to fix or release the door 10 to or from the body 20 may be provided at a second side of the door 10. The locking device may be configured as a press type, and configured to lock the door 10 when the second side of the door 10 is pressed once and release the door 10 when the second side of the door 10 is pressed once again.

The door 10 may include a window unit (or window) 11 and a display unit (or display) 12. When the door 10 is closed, the window unit 11 may correspond to the laundry inlet 20a, and may be configured to view the laundry accommodation portion. Accordingly, the user may check the status of laundry accommodated in the laundry accommodation portion through the window unit 11.

The display unit 12 may displays (outputs) information processed by the laundry treating apparatus 1. The display unit 12 may display the execution screen information of cycles (washing, dehydration, drying cycles, etc.) driven by the laundry treating apparatus 1 or user interface (UI), graphic user interface (GUI) information corresponding to the execution screen information.

Referring to FIGS. 3 and 4, the door 10 may include a door frame 110, a door window 120, a display module 130 and a door cover 140. As described above, the hinge unit 30 for coupling to the body 20 may be mounted on the door 10, but the hinge unit 30 is omitted on the present drawing.

The door 10 may be formed in a circular shape (including a right circular shape, an elliptical shape, or a round shape at least part of which is formed in a round manner). However, the present disclosure may not be necessarily limited to this. The door 10 may be formed in a polygonal shape (rectangular shape, hexagonal shape, etc.). The door frame 110 may be rotatably coupled to the body 20, and to this end, the hinge unit 30 may be coupled to the door frame 110 and body 20, respectively.

The door frame 110 may include an outer frame 111 and an inner frame 112. The outer frame 111 and inner frame 112

5

may be formed of a synthetic resin material (for example, ABS material, PC material, etc.).

The outer frame **111** may face an outside of the body **20**, and the inner frame **112** may face an inside of the body **20** when viewing the door frame **110** itself when the door **10** is closed. The outer frame **111** and inner frame **112** may be also referred to as a first and a second frame, respectively.

The door frame **110** may include a first opening portion **110a** facing the laundry inlet **20a** when the door **10** is closed and a second opening portion **111b** corresponding to the display module **130** mounted in the door frame **110**. The first opening portion **110a** may also be referred to as a door window hole in the aspect that the door window **120** is installed at the first opening portion **110a**, and the second opening portion **111b** may also be referred to as a display hole in the aspect that the display module **130** is mounted at the second opening portion **111b**. The second opening portion **111b** may be located on the first opening portion **110a**.

The first opening portion **110a** may include a front side opening portion **111a** formed on the outer frame **111** and a rear side opening portion **112a** formed on the inner frame **112**. The second opening portion **111b** may be formed on the outer frame **111**. A communication portion **112b** may be formed on the rear side opening portion **112a** of the inner frame **112**, and the display module **130** may be mounted within the door frame **110** through the communication portion **112b**.

The door frame **110** may be installed on the door window **120** to correspond to the first opening portion **110a**. The door window **120** may be formed of a light transmitting material (glass, synthetic resin material, etc.), and arranged to correspond to the laundry inlet **20a** when the door **10** is closed.

The display module **130** may be installed within the door frame **110**. The display module **130** may be provided to correspond to the second opening portion **111b**, and a display **132** provided in the display module **130** may be configured to display visual information associated with information processed in the laundry treating apparatus **1**.

A FPCB hole **111c** through which a flexible printed circuit board (FPCB) of the touch sensor **160** may pass may be provided on the door frame **110**. The FPCB hole **111c** may be provided at one side of the second opening portion **111b**.

The door cover **140** forming an appearance of the door **10** may be coupled to the door frame **110**. The door cover **140** may be formed of a glass material or synthetic resin material having light transmitting characteristics.

The door cover **140** may include a non-light-transmitting region **143**, a first light transmitting region **141** corresponding to the first opening portion **110a**, and a second light transmitting region **142** corresponding to the second opening portion **111b**. The light transmitting region (or transparent region) denotes a region configured to pass at least part of light through which an opposite side thereof or inside thereof is seen.

The first and the second light transmitting regions **141**, **142** are partitioned from each other by the non-light-transmitting region **143**. The door frame **110** and door cover **140** may be formed in a circular shape to connect to the door **10** having a circular shape, and the first and the second light transmitting regions **141**, **142** may be formed in a circular shape to give an integrated aesthetic sense to the user. The circular shape may include a right-circular shape, an oval shape or a round shape in which at least part of the shape is formed in a rounded shape.

For reference, the foregoing configurations being formed in a circular shape are presented as an embodiment, but the present disclosure may not be necessarily limited to this. For

6

example, the first and the second light transmitting region **141**, **142** may be formed in a polygonal shape (rectangular, hexagonal shape or the like) or other geometric shapes as well as a circular shape.

At least part of the door cover **140** may have a bent shape. A first cover portion and a second cover portion at either side of the bending portion may each be formed in an inclined manner with respect to each other by the bent bending portion. Here, the first cover portion and second cover portion may be formed in a flat shape. The door frame **110** may also be formed in such a manner that at least part thereof is bent to correspond to the door cover **140**.

The first light transmitting region **141** may be formed across the first cover portion and bending portion, and the second light transmitting region **142** may be formed on the second cover portion. The second light transmitting region **142** may be smaller than the second opening portion **111b**, and arranged to overlap the second opening portion **111b** when the door cover **140** is coupled to the door frame **110**. Here, overlap may denote overlapping in a thickness direction of the door **10**.

The second opening portion **111b** may be formed in a rectangular shape corresponding to the display module **130** having a rectangular shape, and the second light transmitting region **142** may be formed in a circular shape to overlap within the second opening portion **111b**. In other words, the second light transmitting region **142** may overlap with part of the display module **130**, and the non-light-transmitting region **143** may cover and hide another part of the display module **130**. Visual information may thus be displayed only on a portion corresponding to the second light transmitting region **142** having a circular shape to provide the display unit **12** having a circular shape to the user.

The cost of a circular display may be higher than the cost of a rectangular display **132** that is typically and widely used, and its assembly failure may frequently occur due to difficulties in getting an accurate installation position due to its circular shape. However, according to the foregoing structure, it may be possible to provide a display unit **12** that is seen as a circular shape for the user while using the rectangular display **132** with a lower cost that can be assembled accurately.

The second light transmitting region **142** may be surrounded by the non-light-transmitting region **143**, and thus visual information displayed on a portion of the display **132** that does not correspond to the second light transmitting region **142** within the display **132** may not be seen by the user. Taking this into account, visual information may not be displayed on a portion that does not correspond to the second light transmitting region **142** within the display **132**.

An edge image surrounding the visual information may be displayed on a portion that does not correspond to the second light transmitting region **142** when visual information associated with information processed in the laundry treating apparatus **1** is displayed on a portion of the display **132** corresponding to the second light transmitting region **142**. The edge image as a portion that does not correspond to the second light transmitting region **142** may be filled with a specific series of colors (for example, black).

Alternatively, a portion of the display **132** that does not correspond to the second light transmitting region **142** may be off in a state that visual information associated with information processed in the laundry treating apparatus **1** is displayed on a portion corresponding to the second light transmitting region **142**. In other words, an edge image as well as visual information may not be displayed on a portion of the display **132** that does not correspond to the second

light transmitting region **142** within the display module **130**. Only part of the display **132** may be operated to allow efficient operation of the display **132** compared to the foregoing example in which the whole display **132** is operated, thereby obtaining an energy saving effect.

The display unit **12** formed on the door cover **140** may form an interlayer or integrated structure with the touch sensor **160** to implement the touch screen **12**. The touch screen **12** may provide an output interface between the laundry treating apparatus **1** and the user while at the same time functioning as a user input unit or screen providing an input interface between the laundry treating apparatus **1** and the user. The selection and change of an operation mode for performing washing, dehydration, drying cycles, and the like may be implemented by the user's touch input (or touch).

The touch sensor **160** may be provided at the door **10** to sense a touch input to the door cover **140**. The touch sensor **160** may sense a touch input applied to the display unit (or touch screen) **12** using at least one of various touch methods, such as a resistive method, a capacitive method, an infrared method, an ultrasonic method, a magnetic method, and the like.

The touch sensor **160** may be configured to convert a change such as a pressure applied to a specific portion of the touch screen **12** or a capacitance generated at a specific portion or the like into an electrical input signal. The touch sensor **160** may be configured to detect a position, an area, or a pressure during touch or the like at which an object applying a touch to the display unit **12** is touched on the touch sensor **160**. Here, the object may include a finger, a touch pen or stylus pen, a pointer, or the like.

When there is a touch input to the touch sensor **160** as described above, signal(s) corresponding to the area touched may be sent to the controller. The controller may process the signal(s) and then transmit the corresponding data to the controller. As a result, the controller may know which region of the display unit **12** has been touched. Here, the controller may be an additional configuration to the controller or the controller itself.

The controller may perform a different control operation according to the type of a touch object touching the display unit **12** or perform the same control operation. Whether to perform a different control operation or perform the same control operation according to the type of the touch object may be determined by the operation status of the laundry treating apparatus **1** or an application program being executed. The touch sensor **160** may sense various types of touches such as a short or tap touch, a long touch, a multi touch, a drag touch, a flick touch, a pinch-in touch, a pinch-out touch, a swipe touch, a hovering touch, and the like.

The touch sensor **160** may be configured to sense a touch input to a sensing region including the second light transmitting region **142**. The touch sensor **160** may be adhered to a rear surface of the door cover **140** to cover the second light transmitting region **142** and part of the non-light-transmitting region **143** surrounding the second light transmitting region **142**. According to the foregoing configuration, the sensing region of the touch sensor **160** may include part of the non-light-transmitting region **143** surrounding the second light transmitting region **142** as well as the second light transmitting region **142**. Accordingly, it may be possible to provide various UIs or GUIs using part of the non-light-transmitting region **143** surrounding the second light transmitting region **142**.

According to the foregoing structure, the touch sensor **160** may be formed as a touch film type having a touch pattern, and provided between the door cover **140** and the display module **130**. The touch film may be configured with a transparent conductive film, and previously known films such as an indium tin oxide (ITO) film, a carbon nano tube (CNT) film, or the like may be used for the touch film.

The touch film may be configured with a single or double layer. When the touch film is a glass-film-film (GFF) configured with a double layer, the touch film may be adhered to a rear surface of the door cover **140** or adhered to the display module **130**. When the touch film is a glass-film (GIF) configured with a single layer, the touch film may be adhered to a rear surface of the door cover **140** and integrally formed with the door cover **140**.

The touch sensor **160** may be formed in such a manner that a metal wire is directly patterned on a rear surface of the door cover **140** without an additional touch film [Glass only (G2)]. Alternatively, the touch sensor **160** may be integrally formed with the display **132** provided in the display module **130**. For example, the touch sensor **160** may be provided on a substrate of the display **132** (on-cell) or provided within the display **132** (in-cell).

The operation of the display unit **12** of the laundry treating apparatus **1** may be controlled by the controller. In other words, the controller **180** may control the on/off of the display module **130**, and the display of visual information or image, and may control the on/off of the touch sensor **160**.

The controller may be configured to control whether to activate touch sensing to a region of the display unit **12** that does not correspond to the second light transmitting region **142** within a sensing region of the touch sensor **160**. The controller may be configured to distinguish a state in which touch sensing for a region that does not correspond to the second light transmitting region **142** within the sensing region of the touch sensor **160** is required, from a state in which the touch sensing is not required to deactivate the touch sensing for the non-corresponding region in the state that the touch sensing is not required. According to the control, it may be possible to reduce an error during the user's touch input and obtain an energy saving effect.

Referring to FIG. **6**, the door cover **140** may include a cover body **140a** and a shield layer **140b**. The cover body **140a** may be formed of a light transmitting material. The cover body **140a** may be formed of a light transmitting glass material or synthetic resin material. At least part of the cover body **140a** may be bent.

The shield layer **140b** may cover one surface of the cover body **140a** to form the non-light-transmitting region **143**. The shield layer **140b** may be formed on a front surface or rear surface of the cover body **140a**.

Ink may be printed on a rear surface of the cover body **140a** to form the shield layer **140b**. The ink may include a pigment having a specific series of colors (for example, black, white, blue, etc.). A variety of printing techniques such as screen printing (using a mesh formed of silk, nylon, tetron, stainless steel, etc), offset printing, transfer printing, or the like may be used to form the shield layer **140b**.

The shield layer **140b** may not be provided in the first and the second light transmitting regions **141**, **142**. The first and the second light transmitting regions **141**, **142** may be transparent portions remaining as a light transmitting cover body **140a** without being covered by the shield layer **140b**. The shield layer **140b** may surround the first and the second light transmitting region **141**, **142**, and the first and the second light transmitting region **141**, **142** may be partitioned

from each other by the non-light-transmitting region 143 formed by the shield layer 140b.

The touch sensor 160 may be adhered to a rear surface of the cover body 140a corresponding to the second light transmitting region 142. The touch sensor 160 is may completely cover the second non-light-transmitting region 142, and may sense a touch input to the second non-light-transmitting region 142. The touch sensor 160 may be larger than the second light transmitting region 142. Here, the touch sensor 160 may cover part of the shield layer 140b to restrict the second light transmitting region 142. The touch sensor 160 having a light transparent characteristic and the cover body 140a having a light transparent characteristic may be sequentially provided at a front side of the display 132 provided in the display module 130.

Referring to FIG. 7, the transparency of the shield layer 140b to restrict the first light transmitting region 141 within the door cover 140 may be formed to gradually vary as being located closer to the first light transmitting region 141. The non-light-transmitting region 143 adjacent to the first light transmitting region 141 may gradually become more transparent in a direction toward the first light transmitting region 141. The shield layer 140b may include a plurality of shield dots 140b' formed adjacent to the first light transmitting region 141, and the density of the plurality of shield dots 140b' may decrease in a direction toward the first light transmitting region 141.

By blurring a boundary to the first light transmitting region 141 through such a halftone technique, the non-light-transmitting region 143 may visually and naturally change to the first light transmitting region 141. On the contrary, the second light transmitting region 142 and the non-light-transmitting region 143 configured to surround the same may be clearly divided in the form of a boundary line by the non-light-transmitting region 143.

Contrary to the foregoing first embodiment in which the shield layer 140b is printed on a rear surface of the cover body 140a, a film 2140b that forms a non-light-transmitting region 2143 may be adhered to a rear surface of the cover body 2140a. As showing in FIG. 8, the film 2140b may include a non-light-transmitting portion 2140b3 corresponding to the non-light-transmitting region 2143, a first light transmitting portion 2140b1 corresponding to a first light transmitting region 2141 and a second light transmitting portion 2140b2 corresponding to a second light transmitting region 2142. The non-light-transmitting portion 2140b3 may surround the first and the second light transmitting portions 2140b1, 2140b2, and the first and the second light transmitting portions 2140b1, 2140b2 may be partitioned from each other by the non-light-transmitting portion 2140b3.

A portion corresponding to the non-light-transmitting portion 2140b3 may function as a shield layer to allow a door cover 2140 to be non-transparent to form the non-light-transmitting region 2143. A portion corresponding to the first and the second light transmitting portions 2140b1, 2140b2 may form the first and the second light transmitting regions 2141, 2142, respectively, along with the light transmitting cover body 2140a.

The first and the second light transmitting regions 2141, 2142 may be formed by allowing the first and the second light transmitting portions 2140b1, 2140b2, respectively, which are a transparent portion of the film 2140b to be provided on the light transmitting cover body 2140a.

The touch sensor 2160 may be adhered to a rear surface of the film 2140b corresponding to the second light transmitting portion 2140b2. The touch sensor 2160 may completely cover the second light transmitting region 2142, and

may sense a touch input to the second light transmitting region 2142. The touch sensor 2160 may be larger than the second light transmitting region 2142, and may be configured to cover part of the non-light-transmitting portion 2140b3 to restrict the second light transmitting portion 2140b2. The touch sensor 2160 having a light transparent characteristic, the second light transmitting portion 2140b2 of the film 2140b, and the cover body 2140a having a light transparent characteristic may be sequentially arranged at a front side of the display 132 provided in the display module 130.

A film 3140b that forms a shield layer 3140b may be adhered to a rear surface of the cover body 3140a. As illustrated in FIG. 9, the film 3140b may include a non-light-transmitting portion 3140b3 corresponding to the non-light-transmitting region 3143, a first hole 3140b1 corresponding to a first light transmitting region 3141 and a second hole 3140b2 corresponding to a second light transmitting region 3142. The non-light-transmitting portion 3140b3 may surround the first and second holes 3140b1, 3140b2, and the first and second holes 3140b1, 3140b2 may be partitioned from each other by the non-light-transmitting portion 3140b3.

A portion of the film 3140b corresponding to the non-light-transmitting portion 3140b3 may function as a shield layer to allow the door cover 3140 to be non-transparent to form the non-light-transmitting region 3143. The first and second holes 3140b1, 3140b2 may be formed on a portion of the film 3140b corresponding to the first and the second light transmitting regions 3141, 3142. Thus, the film 3140b may not be provided on the first and second light transmitting regions 3141, 3142.

The touch sensor 3160 may be adhered to a rear surface of the film 3140b corresponding to the second light transmitting region 3142. The touch sensor 3160 may completely cover the second light transmitting region 3142, and may sense a touch input to the second light transmitting region 3142. The touch sensor 3160 may be larger than the second light transmitting region 3142, and may be configured to cover part of the non-light-transmitting portion 3140b3 to restrict the second light hole 3140b2. The touch sensor 3160 having a light transparent characteristic and the cover body 3140a having a light transparent characteristic may be sequentially provided at a front side of the display 132 provided in the display module 130.

The touch sensor 160, 3160 may be directly adhered to the transparent cover body 140a, 3140a, thereby increasing a touch sensitivity felt by a user. The second light transmitting portion 2140b2 of the film 2140b may not be provided at a front side of the display 132, to more clearly provide visual information displayed on the display 132. Meanwhile, the method of attaching the film 2140b, 3140b onto the door cover 2140, 3140 illustrated in FIGS. 8 and 9 may be an in-mold injection, a transfer method, and the like.

The in-mold injection may be used when the door cover 2140, 3140 is made of synthetic resin, and may be a method in which the film 2140b, 3140b is placed in a mold and integrally formed with the door cover 2140, 3140. The transfer method may be a method of attaching the film 2140b, 3140b onto the door cover 2140, 3140 made of glass or synthetic resin through heat transfer pressing.

Referring to FIG. 10, the door cover 140 may be coupled to the door frame 110 using a liquid phase sealant 171. A coupling structure between the door cover 140 and the door frame 110 will be described in detail later. The door frame 110 may include an outer frame 111 and an inner frame 112.

11

The door cover **140** may be adhered to a front surface of the outer frame **111**. The inner frame **112** may be coupled to a rear side of the outer frame **111**. The outer frame **111** and the inner frame **112** may be coupled by a screw coupling, a hook coupling, a bonding coupling, or the like.

The outer frame **111** and the inner frame **112** may be coupled to each other by a bonding coupling. Specifically, a fastening rib **112d** may be formed in a protruding manner on the inner frame **112**, and a rib accommodation portion **111e** to accommodate the fastening rib **112d** may be formed in a protruding manner on a rear surface of the outer frame **111**, and a bonding member **172** may be filled into the rib accommodation portion **111e**.

During coupling between the outer frame **111** and the inner frame **112**, an outer circumferential portion of the inner frame **112** may be formed in a protruding manner on a front surface of the outer frame **111** to form a mounting guide **112c**. The mounting guide **112c** is extended in a loop shape along a circumference of the outer frame **111** to form a space that accommodates the door cover **140** therein.

The mounting guide **112c** may cover a lateral surface of the door cover **140**, and an upper surface of the mounting guide **112c** may be formed in a protruding manner at a predetermined height to be coplanar with an upper surface of the adjoining door cover **140**. According to the foregoing configuration, a step between the mounting guide **112c** and the door cover **140** may be decreased to implement a simpler design.

In general, a portion (for example, a vertex portion, a concave portion, etc.) having a unique shape may be a reference point capable of adjusting an installation position during assembly, thereby facilitating the assembly. However, when the door cover **140** is formed in a circular shape, an apex portion has a round shape, and a portion capable of adjusting an installation position during assembly may be unsuitable. In particular, unless the door cover **140** is coupled to an accurate position on the door frame **110**, the first and the second light transmitting region **141**, **142** of the door cover **140** may not correspond to the first and the second opening portion **110a**, **111b** of the door frame **110**.

As illustrated in FIG. **11**, the door cover **140** may include a portion that will be a reference point capable of adjusting an installation position while being assembled to the door frame **110**. The door cover **140** may include a first edge portion **140'** formed in a round manner and a second edge portion **140''** that connects both sides of the first edge portion **140'**. The door cover **140** may have a circular shape with a portion cut in a linear form. The second edge portion **140''** may have any form that is distinguishable in shape from the first edge portion **140'** such as a linear form, a rugged form, or the like.

The foregoing mounting guide **112c** may include a first protrusion portion **112c'** extended in a round manner to correspond to the first edge portion **140'** and a second protrusion portion **112c''** extended in a linear shape to correspond to the second edge portion **140''**. The second edge portion **140''** and second protrusion portion **112c''** may be a reference point capable of adjusting an installation position during assembly between the door cover **140** and the door frame **110**.

When the second edge portion **140''** corresponds to the second protrusion portion **112c''**, the door cover **140** may be located at a normal position on the door frame **110**, and thus the first and the second light transmitting regions **141**, **142** of the door cover **140** may correspond to the first and the second opening portions **110a**, **111b** of the door frame **110**. The second protrusion portion **112c''** may be located at any

12

position of the door frame **110**, but the second protrusion portion **112c''** may be preferably formed at a lower side of the door frame **110**.

Hereinafter, a coupling structure between the door cover **140** and the door frame **110** will be described. The door **10** may be coupled to a front surface of the outer frame **111** using a sealant **171**, and a sealant filling groove **111d** into which the sealant **171** is filled may be formed on a front surface of the outer frame **111**.

The sealant filling groove **111d** may surround the first opening portion **110a** and second opening portion **111b**, respectively. The sealant filling groove **111d** may include a connecting groove portion **111d'3**, a first groove portion **111d'1** and a second groove portion **111d'2**.

The connecting groove portion **111d'3** may cross between the first and the second opening portion **110a**, **111b**. The connecting groove portion **111d'3** may be formed in a linear shape or a bent shape on at least one portion thereof (for example, in a U-shape surrounding both sides and a lower side of the second opening portion **111b**) as illustrated in the drawing.

The first groove portion **111d'1** may be connected to both end portions of the connecting groove portion **111d'3**, and formed to surround a circumference of the first opening portion **110a** along with the connecting groove portion **111d'3**. The first groove portion **111d'1** may be extended along an inner circumference of the outer frame **111**.

The second groove portion **111d'2** may be connected to both end portions of the connecting groove portion **111d'3**, and formed to surround a circumference of the second opening portion **111b** along with the connecting groove portion **111d'3**. The second groove portion **111d'2** may be extended along an inner circumference of the outer frame **111**.

The first groove portion **111d'1** and the second groove portion **111d'2** may communicate with each other at both end portions of the connecting groove portion **111d'3**. The first and the second groove portion **111d'2** may extend along an inner circumference of the outer frame **111** to form a circular groove, and the connecting groove portion **111d'3** may extend in a linear shape to cross an inside of the circular groove.

The sealant filling groove **111d** may include a sealant coating portion **111d'** and a sealant collecting portion **111d''**. The sealant coating portion **111d'** as a portion for the filling of the sealant **171** may include the foregoing connecting groove portion **111d'3**, first groove portion **111d'1** and second groove portion **111d'2**.

The sealant collecting portion **111d''** may collect the sealant **171** leaked out of an inner and an outer side of the sealant coating portion **111d'**, respectively, and may be provided at both sides of the sealant coating portion **111d'**. The sealant collecting portion **111d''** may be extended in parallel along the sealant coating portion **111d'** while spaced apart from the sealant coating portion **111d'** by interposing a predetermined distance therebetween. The sealant collecting portion **111d''** may have a smaller width than that of the sealant coating portion **111d'**.

A projection **111f** may protrude to a predetermined height between the sealant coating portion **111d'** and the sealant collecting portion **111d''**. The projection **111f** may protrude to a height corresponding to a front surface of the outer frame **111**, and the projection **111f** may function as a supporting surface that supports the door cover **140**.

The sealant collecting portion **111d''** may include a first through a third sealant collecting portion **111d''1**, **111d''2**, **111d''3**. The first sealant collecting portion **111d''1** may be

13

provided at an inner side of the sealant coating portion 111d', and formed to surround the first opening portion 110a. The first sealant collecting portion 111d'1 may extend along the connecting groove portion 111d'3 and the first groove portion 111d'1.

The second sealant collecting portion 111d'2 may be provided at an inner side of the sealant coating portion 111d', and formed to surround the second opening portion 111b. The second sealant collecting portion 111d'2 may extend along the connecting groove portion 111d'3 and the second groove portion 111d'2.

The third sealant collecting portion 111d'3 may be provided at an outer side of the sealant coating portion 111d', and formed to surround the sealant collecting portion 111d'. The third sealant collecting portion 111d'3 may extend along the first groove portion 111d'1 and the second groove portion 111d'2, and may have a circular shape.

According to the foregoing configuration, even if the sealant 171 filled into the sealant coating portion 111d' leaks out during the process of coupling the door cover 140 to the outer frame 111, the sealant 171 leaked out to the sealant collecting portion 111d' may be collected. As a result, it may be possible to prevent the deterioration of appearance quality due to the leakage of the sealant 171.

The sealant coating portion 111d' may be adjacent to an edge portion of the outer frame 111. Accordingly, it may be possible to minimize a non-joint portion on an edge portion of the corresponding door cover 140, thereby enhancing the joint strength, and effectively preventing foreign substances from being infiltrated through a gap between the door cover 140 and the outer frame 111.

Referring to FIG. 14, a sealant filling groove 4111d may include a connecting groove portion 4111d'3, a first groove portion 4111d'1 and a second groove portion 4111d'2, and may surround a first and a second opening portion 4110a, 4111b, respectively. The sealant filling groove 4111d may include a sealant coating portion and a sealant collecting portion, and the description thereof will be the same as that of the foregoing first embodiment.

The sealant filling groove 4111d may further include a bypass groove portion 4111d'4 to connect between an arbitrary point on the connecting groove portion 4111d'3 and an arbitrary point on the first groove portion 4111d'1. The bypass groove portion 4111d'4 may be located within a space formed by the connecting groove portion 4111d'3 and the first groove portion 4111d'1.

As a result, part of the sealant filled into the connecting groove portion 4111d'3 or first groove portion 4111d'1 may be introduced into the branched bypass groove portion 4111d'4, thereby increasing a number of couplings between the door cover and the door frame 4110. Accordingly, it may be possible to increase a coupling force between the door cover and the door frame 4110.

The bypass groove portion 4111d'4 may include a sealant coating portion for the filling of sealant, and a sealant collecting portion provided at both sides of the sealant coating portion to collect sealant leaked out of an inner and an outer side of the sealant coating portion, respectively. The display module 130 may be integrated into the door frame 110, and because the door 10 opens and closes the laundry inlet 20a, moisture may leak into the display module 130. Accordingly, the sealing of the display module 130 may be a key point in the aspect of securing the reliability of driving the display unit 12.

Hereinafter, a sealing structure of the display module 130 will be described. Referring to FIGS. 15 through 19, the

14

display module 130 may include a mounting frame 131, a display 132 and a display sealing member 133.

The mounting frame 131 may include a display mounting portion 131a in which the display 132 is mounted on one surface thereof. The display mounting portion 131a may include a space recessed on a front surface of the mounting frame 131 toward a rear surface of the mounting frame 131 in a shape corresponding to the display 132 or an internal space restricted by a rib formed in a protruding manner to correspond to a circumference of the display 132. The mounting frame 131 may be formed of a synthetic resin material (for example, ABS material, PC material, etc.).

A communication hole 131b may be formed on the mounting frame 131. The communication hole 131b may be provided at one side of the display mounting portion 131a, and may be a space distinguished from the display mounting portion 131a. A flexible printed circuit board 161 of the touch sensor 160 may be electrically connected to a printed circuit board 135 through the FPCB hole 111c formed on the door frame 110 and the communication hole 131b formed on the mounting frame 131. A flexible printed circuit board of the display 132 as well as the flexible printed circuit board 161 of the touch sensor 160 may pass through the communication hole 131b.

The display 132 may be mounted on the mounting frame 131 to display visual information. The display 132 may include at least one of a liquid crystal display (LCD), a thin film transistor-liquid crystal display (TFT LCD), an organic light-emitting display diode (OLED), a flexible display, a three-dimensional (3D) display, and an e-ink display.

For the display 132, a typically and widely used tetragonal display, more particular, a rectangular display 132 having different horizontal and vertical lengths may be used. As described above, the rectangular display 132 has a lower cost compared to a circular display, and has an advantage of facilitating an accurate mounting position while mounting on the mounting frame 131 due to a portion having a unique shape (having a vertex, different horizontal and vertical lengths).

When the display 132 is a rectangular shape, and the second light transmitting region 142 is a circular shape, the length of a shorter portion between the horizontal and vertical lengths may be larger than the diameter of the second light transmitting region 142 (a major axis of the second light transmitting region 142 when the second light transmitting region 142 is formed in an elliptical shape). When the above condition is satisfied, visual information may be displayed on the whole second light transmitting region 142.

Though the rectangular display 132 may be used for the display 132, a circular display unit 12 may be provided for the user. A circular second light transmitting region 142 configured to overlap with the display 132 may be formed on the door cover 140. Moreover, the controller may control the display of visual information on a portion of the display 132 that does not correspond to the second light transmitting region 142 within the display 132, thereby reducing power.

A display cover 134 formed of a light transmitting material, and covering the display 132 may be additionally provided on the display 132. The display cover 134 may cover and protect the display 132. The display cover 134 may be formed of a synthetic resin material (for example, acryl material, PET material, TPU material, etc.).

The display sealing member 133 may be provided between the door frame 110 and the mounting frame 131, and formed to surround the display 132. When the communication hole 131b is provided in the mounting frame 131,

the display sealing member **133** may be preferably formed to surround the display **132** at the same time.

The display sealing member **133** may be fixed to the door frame **110** or fixed to the mounting frame **131**. The display sealing member **133** may be fixed to the mounting frame **131** to seal an internal space when the mounting frame **131** is mounted on the door frame **110**. An accommodation groove **131f** to fix the display sealing member **133** may be formed on the mounting frame **131**, and the accommodation groove **131f** may be formed to surround the display **132**.

The display sealing member **133** may include a plurality of contact portions **133a**, **133b**. The contact portions **133a**, **133b** may be separated from each other in a width direction, and may extend in parallel along a length direction of the display sealing member to form a plurality of sealing loops. Accordingly, a sealing loop formed by either one of the contact portions **133a**, **133b** may be provided within a sealing loop formed by the other one of the contact portions **133a**, **133b**, thereby enhancing the reliability of the sealing structure.

The display module **130** may further include a printed circuit board (PCB) **135**, a PCB cover **137**, and a PCB sealing member **138**. The printed circuit board **135** may be electrically connected to the display **132**, and mounted on the mounting frame **131**. The display **132** may be mounted on a front surface of the mounting frame **131**, and the printed circuit board **135** may be mounted on a rear surface of the mounting frame **131**. When the touch sensor **160** is provided therein, the printed circuit board **135** may be electrically connected to the flexible printed circuit board **161** of the touch sensor **160** that passes through the communication hole **131b**. The printed circuit board **135** may control the operation of the display **132** and touch sensor **160** or the controller itself.

A printed circuit board mounting portion **131d** may be provided on a rear surface of the mounting frame **131** to mount the printed circuit board **135**. The printed circuit board mounting portion **131d** may be recessed on a rear surface of the mounting frame **131** toward a front surface of the mounting portion **131** in a shape corresponding to the printed circuit board **135** or an internal space restricted by a rib formed in a protruding manner to correspond to a circumference of the printed circuit board **135**.

A wireless communication module **136** capable of performing wireless communication with an internal external device or external electronic device may be additionally mounted on the mounting frame **131**. A wireless communication module mounting portion **131e** in which to mount the wireless communication module **136** may be provided on the mounting frame **131**, and the wireless communication module mounting portion **131e** may be located at one side of the printed circuit board mounting portion **131d**.

The wireless communication module **136** may include at least one of Wi-Fi, Bluetooth, and a communication module using RF. For example, the laundry treating apparatus **1** may perform wireless communication with the user's mobile terminal through a Wi-Fi communication module or Bluetooth communication module. The laundry treating apparatus **1** may also be configured to perform wireless communication with another home appliance (for example, another laundry treating apparatus **1** through the RF communication module.

The PCB cover **137** may be mounted on the mounting frame **131**, and may cover the printed circuit board **135**. The PCB cover **137** may be fastened to the mounting frame **131** by a screw coupling, a hook coupling, a bonding coupling, or the like. A mounting portion **137a** formed with a mount-

ing hole may be provided on the mounting frame **131**, and a mounting member **139b** may be screw-coupled to the mounting frame **131** through the mounting hole.

A PCB sealing member **138** may be provided between the mounting frame **131** and the PCB cover **137**, and configured to seal a gap between the mounting frame **131** and the PCB cover **137**. The PCB sealing member **138** may surround the printed circuit board **135**, and may prevent moisture from leaking into the printed circuit board **135**.

When the wireless communication module **136** is additionally provided, the PCB sealing member **138** may preferably surround the printed circuit board **135** and wireless communication module **136** at the same time. Furthermore, when the communication hole **131b** is provided on the mounting frame **131**, it may preferably surround the communication hole **131b** at the same time.

The PCB sealing member **138** may be fixed to the mounting frame **131** or fixed to the PCB cover **137**. The PCB sealing member **138** may be fixed to the mounting frame **131**, and configured to seal an internal space when the mounting frame **131** is coupled to the PCB cover **137**. A mounting groove **131g** to fix the PCB sealing member **138** may be formed on the mounting frame **131**, and the mounting groove **131g** may surround the printed circuit board **135**. If it has a structure in which the PCB sealing member **138** is fixed to the PCB cover **137**, a mounting groove to fix the PCB sealing member **138** may be formed on the PCB cover **137**.

The PCB sealing member **138** may include a plurality of contact portions **138a**, **138b**. The contact portions **138a**, **138b** may be separated from each other in a width direction, and may extend in parallel along a length direction of the PCB sealing member **138** to form a plurality of sealing loops. Accordingly, a sealing loop formed by either one of the contact portions **138a**, **138b** may be provided within a sealing loop formed by the other one of the contact portions **138a**, **138b**, thereby enhancing the reliability of the sealing structure.

Referring to FIG. **20**, the display module **130** may be mounted on one side of the door frame **110** when the door cover **140** is mounted on the other side of the door frame **110**. The mounting frame **131** may be fastened to the door frame **110** by a screw coupling, a hook coupling, a bonding coupling, or the like. A fastening portion **131c** formed with a fastening hole may be provided on the mounting frame **131**, and a fastening member **139a** may be screw-coupled to the door frame **110** through the fastening hole.

When a door frame **110** includes an outer frame **111**, an inner frame **112**, and a frame cover **150**, the door cover **140** may be mounted on a front surface of the outer frame **111**, and the mounting frame **131** may be mounted on a rear surface of the outer frame **111** to correspond to the second opening portion **111b**. The display sealing member **133** may seal a gap between the mounting frame **131** and the outer frame **111** when the mounting frame **131** is mounted on the outer frame **111**. The display sealing member **133** may be closely adhered to a mounting surface of the outer frame **111** adjacent to the second opening portion **111b**, and formed to surround the second opening portion **111b**.

When the display sealing member **133** is fixed to the mounting frame **131**, an accommodation groove **131f** may be formed on the mounting frame **131**, and configured to insert and fix part of the display sealing member **133** to the accommodation groove **131f**. Another part of the display sealing member **133** may protrude from the accommodation groove **131f**, and may contact the door frame **110** when the mounting frame **131** is mounted on the door frame **110**. Due

to the contact, an inner space of the display sealing member **133** may be separated from an outer space of the display sealing member **133**, thereby preventing moisture from leaking into the inner space.

The display sealing member **133** may be fixed to a rear surface of the outer frame **111**, and in this case, the accommodation groove **131f** for fixing the sealing member may be provided on a rear surface of the outer frame **111**. On the other hand, a filler **133'** may be filled into a gap between the mounting frame **131** and the display cover **134** when the display **132** is mounted on the display mounting portion **131a**. The filler **133'** may fill the gap, thereby preventing moisture from leaking into the display **132**.

Referring to FIG. **21** along with the foregoing FIG. **20**, the inner frame **112** may be coupled to a rear side of the outer frame **111**, and may cover the display module **130**. The display module **130** may be provided in an internal space formed by a coupling between the outer frame **111** and the inner frame **112**.

The communication portion **112b** configured to communicate with the internal space may be formed on the inner frame **112**, and the display module **130** may be inserted into the internal space through the communication portion **112b**, and then installed on the outer frame **111**. A fastening boss corresponding to a fastening portion of the mounting frame **131** may be formed on the outer frame **111**, and the fastening member **139a** may be fastened to the fastening boss through the fastening hole of the fastening portion **131c**.

The printed circuit board **135** may be electrically connected to a controller and a power supply unit of the body **20**. A door side cable extended from the printed circuit board **135** may be connected to a connector provided within the outer frame **111**, and the connector may be electrically connected to a body side cable electrically connected to the controller and power supply unit of the body **20**.

The door side cable may pass through a through hole of the PCB cover **137**, and a sealing member may be interposed between the door side cable and the through hole. The sealing member may be formed to surround the door side cable, and may be closely adhered to an inner circumferential surface of the PCB cover **137** forming the through hole.

The frame cover **150** configured to open and close the communication portion **112b** may be detachably coupled to the inner frame **112**. The frame cover **150** may be fastened to the inner frame **112** by a screw coupling, a hook coupling, or the like. An engagement hook **151** may be protruded on the frame cover **150**, and an engagement hole (or engagement groove) **112b'** configured to be engaged with the engagement hook **151** may be formed on the inner frame **112**.

Hereinafter, a modified example of the foregoing laundry treating apparatus will be described. The detailed structured of the foregoing door will be applicable as a whole to the following door unless it contradicts to the detailed description of the following door. Accordingly, the redundant description thereof will be omitted.

Referring to FIGS. **22** and **23**, the door **1010** may include a door cover **1140**, a display module **1130** and a door frame **1110**. The door cover **1140** may include a non-light-transmitting region **1143** and a first light transmitting region **1141** and a second light transmitting region **1142** within the non-light-transmitting region **1143**. The first and the second light transmitting region **1141**, **1142** may be divided from each other by the non-light-transmitting region **1143**.

The display module **1130** may be provided on a rear surface of the door cover **1140**. The display module **1130** may display visual information through the second light

transmitting region **1142**. The display module **1130** may be directly adhered to a rear surface of the door cover **1140** or mounted on the display module accommodation portion **1110b** of the following door frame **1110**.

The door frame **1110** may be coupled to the door cover **1140**, and connected to the body **20** in a relatively movable manner. The door frame **1110** may rotate with respect to the body **20** by the hinge unit **30**.

The door frame **1110** may include an outer frame **1111** and an inner frame **1112**. The outer frame **1111** and inner frame **1112** may be formed of a synthetic resin material (for example, ABS material, PC material, etc.). The door frame **1110** may include a display module accommodation module **1110b** and an opening portion **1110a**.

The display module accommodation module **1110b** may be a recessed space and may accommodate the display module **1130**. The display module accommodation module **1110b** may be a hole formed in the outer frame **1111** itself configured with a recessed space. The inner frame **1112** may cover the hole formed on the outer frame **1111**. The display module accommodation module **1110b** may be configured to accommodate a flexible printed circuit board **1161** of the touch sensor **1160**.

The display module **1130** may have a shape covered by the display module accommodation module **1110b**. In other words, the display module **1130** may be provided between the door cover **1140** and the door frame **1110**. Certainly, a second opening portion corresponding to the display module **1130** may not be provided on the door frame **1110**.

The opening portion **1110a** may face the laundry inlet **20a** when the door **1010** is closed. A light transmitting door window **1120** may be installed on the opening portion **1110a**, and configured to view the laundry inlet **20a** through the door window **1120**.

The opening portion **1110a** may include a front side opening portion **1111a** formed on the outer frame **1111** and a rear side opening portion **1112a** formed on the inner frame **1112**. A sealant filling groove **1111d** configured to fill sealant to the door cover **1140** may be formed on a front surface of the door frame **1110**.

The sealant filling groove **1111d** may include a connecting groove portion, a first groove portion and a second groove portion. Specifically, the connecting groove portion may cross between the display module accommodation module **1110b** and the opening portion **1110a**, and the first groove portion may be connected to both end portions of the connecting groove portion to surround a circumference of the opening portion **1110a** along with the connecting groove portion, and the second groove portion may be connected to both end portions of the connecting groove portion to surround a circumference of the display module accommodation module **1110b** along with the connecting groove portion.

The sealant filling groove **1111d** may further include a bypass groove portion in addition to the foregoing configuration. The bypass groove portion may connect an arbitrary point on the connecting groove portion with an arbitrary point on the first groove portion within a space formed by the connecting groove portion and the first groove portion. Furthermore, the sealant filling groove **1111d** may include a sealant coating portion **1111d'** and a sealant collecting portion **1111d''**.

Due to the sealant filling groove **1111d**, it may be possible to prevent moisture from leaking into the display module **1130** provided between the door cover **1140** and the door frame **1110**. Furthermore, the sealant filling groove **1111d** may separately surround the display module accommoda-

tion module 1110b and the opening portion 1110a, respectively, thereby preventing moisture from leaking into the display module 1130 through the opening portion 1110a.

When the display module 1130 is directly adhered to a rear surface of the door cover 1140, a display sealing member 1133 may be closely adhered to a rear surface of the door cover 1140. Here, the display sealing member 1133 may also function as an adhesive to couple the display module 1130 to a rear surface of the door cover 1140.

The present modified examples have the same solving task as that of the foregoing structure illustrated in FIG. 11. In other words, the first light transmitting region 1241, 1341, 1441 and the second light transmitting region 1342, 1442 of the door cover 1240, 1340, 1440 correspond to a first opening portion 1210a, 1311a, 1411a and a second opening portion 1311b, 1411b of the door frame 1210, 1340, 1440 when the circular door cover 1240, 1340, 1440 is mutually coupled to the circular door frame 1210, 1311, 1411.

First, referring to FIG. 24, the mounting guide 1240', 1240" that guides the mounting of the door frame 1210 may protrude along a rear circumference of the door cover 1240. When the mounting guide 1240', 1240" is provided in the door cover 1240, the present modified example may be applicable when the door cover 1240 is formed of a synthetic resin material.

The mounting guide 1240', 1240" may have a shape and size corresponding to an appearance of the door frame 1210 such that the door frame 1210 may be mounted on an inner space formed by the mounting guide 1240', 1240". Moreover, the following structure may be provided between the door cover 1240 and the door frame 1210 to implement a coupling between the door cover 1240 and the door frame 1210 at an accurate position.

The door frame 1210 may include a first edge portion 1210' formed in a round manner and a second edge portion 1210" to connect both sides of the first edge portion 1210'. The door frame 1210 may have a circular shape in which part thereof is cut in a linear form. The second edge portion 1210" may have any form that is distinguishable in shape from the first edge portion 1210' such as a linear form, a rugged form, or the like.

The foregoing mounting guide 1240', 1240" may include a first protrusion portion 1240' extending in a round manner to correspond to the first edge portion 1210' and a second protrusion portion 1240" extending in a linear shape to correspond to the second edge portion 1210". A front surface of the door cover 1240 formed with the second protrusion portion 1240" may have a rounded shape so that the front surface of the door cover 1240 has a circular shape. A portion formed with the second protrusion portion 1240" may have an angled shape when the door cover 1240 is seen from a rear surface thereof, but may be seen in a circular shape with no angled portion when the door cover 1240 is seen from a front surface thereof.

A front surface of the door cover 1240 formed with the second protrusion portion 1240" may have a radius of curvature which is substantially the same as that of a front surface of the door cover 1240 formed with the first protrusion portion 1240'. In this case, the door cover 1240 may have a complete circular shape when viewed from the front, thereby implementing a simple and neat appearance of the door.

In the foregoing configuration, the second edge portion 1210" and the second protrusion portion 1240" may be capable of adjusting an installation position during the assembly between the door cover 1240 and the door frame 1210. When the second edge portion 1210" corresponds to

the second protrusion portion 1240", the door frame 1210 may be located at an exact position on the door cover 1240, and thus the first light transmitting region 1241 and the second light transmitting region of the door cover 1240 may correspond to the first opening portion 1210a and the second opening portion.

Next, referring to FIGS. 25 and 26, the door frame (on the present drawing, only the outer frame 1311, 1411 of the door frame is illustrated) and the door cover 1340, 1440 may have mounting guides, respectively, to guide an exact installation position during mutual coupling. The mounting guides may respectively include an alignment groove 1340c, 1440c and an alignment protrusion 1311g, 1411g coupled to each other.

The alignment groove 1340c, 1440c may be concave on either one of the door frame 1311, 1411 and the door cover 1340, 1440, and the alignment protrusion 1311g, 1411g may protrude on the other one of the door frame 1311, 1411 and the door cover 1340, 1440, and thus may be inserted into the alignment groove 1340c, 1440c during mutual coupling between the door frame 1311, 1411 and the door cover 1340, 1440.

The alignment groove 1340c, 1440c and alignment protrusion 1311g, 1411g may be formed within the non-light-transmitting region 1343, 1443. In other words, the alignment groove 1340c, 1440c and the alignment protrusion 1311g, 1411g may overlap with a shielding layer forming the non-light-transmitting region 1343, 1443. The alignment groove 1340c, 1440c and the alignment protrusion 1311g, 1411g may not be seen from an outside of the door, thereby implementing a simple and neat appearance of the door.

FIG. 25 illustrates that the alignment groove 1340c (1340c', 1340c") may be formed on the door cover 1340 and the alignment protrusions 1311g (1311g', 1311g") may be formed on the door frame 1311. The formation positions of the alignment groove 1340c and the alignment protrusion 1311g may be of course interchanged with each other.

When the alignment protrusion 1311g is formed in a circular protrusion shape and only one is provided, the alignment protrusion 1311g may be inserted into the alignment groove 1340c in a rotational manner, and thus an accurate alignment between the door cover 1340 and the door frame 1311 may not be carried out. Accordingly, a plurality of alignment protrusions 1311g may be provided, and thus formed in a protruding manner at a plurality of positions.

The alignment grooves 1340c', 1340c" may be formed at an upper end of the door cover 1340 adjacent to the second light transmitting region 1342 and a lower end of the door cover 1340 adjacent to a lower side of the first light transmitting region 1341, respectively. However, the alignment groove 1340c may also be provided in a non-light-transmitting region 1343 between the first light transmitting region 1341 and the second light transmitting region 1342, and formed anywhere if they are positions separated from each other within the non-light-transmitting region 1343.

FIG. 26 illustrates that the alignment protrusion 1411g (1411g', 1411g") may extend in a rib shape along at least one direction. The alignment groove 1440c (1440c', 1440c") may have a shape corresponding to the alignment protrusion 1411g.

According to a coupling between the alignment protrusion 1411g and the alignment groove 1440c, rotation may be restricted subsequent to inserting the alignment protrusion 1411g into the alignment groove 1440c, thereby implementing an accurate alignment between the alignment groove 1440c and the door frame 1411. Even when only one

alignment protrusion 1411g is provided, it may be possible to obtain the same effect as illustrated above in FIG. 25.

Alignment grooves 1440c', 1440c" may extend in a horizontal direction to both sides of the first light transmitting region 1441, respectively. However, the alignment groove 1440c may be extended in a horizontal direction from a non-light-transmitting region 1443 between the first light transmitting region 1441 and the second light transmitting region 1442.

A laundry treating apparatus may include a body provided with a laundry inlet; and a door configured to open and close the laundry inlet, wherein the door includes a door frame having a first opening portion facing the laundry inlet inside in a state that the door is closed and a second opening portion corresponding to a display module mounted at an inside; and a door cover coupled to the door frame to form an appearance of the door, and the door cover includes a non-light-transmitting region, and a first light transmitting region corresponding to the first opening portion and a second light transmitting region corresponding to the second opening portion within the non-light-transmitting region.

The second light transmitting region may be smaller than the second opening portion, and provided within the second opening portion when the door cover is coupled to the door frame. The second opening portion may be a rectangular shape corresponding to the display module having a rectangular shape, and the second light transmitting region may be a circular shape overlapping within the second opening portion, and visual information may not be displayed on a portion that does not correspond to the second light transmitting region of the display module.

A touch sensor disposed to cover the second light transmitting region to sense a touch input to a sensing region containing the second light transmitting region may be adhered to a rear surface of the door cover. The laundry treating apparatus may further include a controller configured to control whether to activate touch sensing to a region that does not correspond to the second light transmitting region within the sensing region.

The door cover may include a cover body formed of a light transmitting material; and a shield layer disposed to cover a rear surface of the cover body to form the non-light-transmitting region. The first and the second light transmitting regions may be a portion at which the shield layer is not provided. The shield layer may include a plurality of shield dots formed adjacent to the first light transmitting region, and the shield dots may be formed to decrease in density when located closer to the first light transmitting region.

A mounting guide surrounding an outer circumference of the door cover may be formed in a protruding manner on the door frame along a circumference thereof. The door cover may include a first edge portion formed in a round manner and a second edge portion to connect both sides of the first edge, and the mounting guide may include a first protrusion portion extending in a round manner to correspond to the first edge portion and a second protrusion portion corresponding to the second edge portion to guide a mounting position when the door cover is mounted on the door frame.

The second protrusion portion may be formed at a lower side of the door frame. The door frame may include an outer frame formed with a sealant filling groove to fill sealant to adhere to the door cover on a front surface thereof; and an inner frame coupled to a rear side of the outer frame, and formed such that an outer circumferential portion thereof protrudes from a front surface of the outer frame during the coupling to form the mounting guide.

The sealant filling groove may include a sealant coating portion for filling sealant; and a sealant collecting portion formed at both sides of the sealant coating portion, respectively, to collect sealant leaked out of an inner and an outer side of the sealant coating portion, respectively. The sealant filling groove may include a connecting groove portion formed to cross between the first and the second opening portion; a first groove portion connected to both end portions of the connecting groove portion, and formed to surround a circumference of the first opening portion along with the connecting groove portion; and a second groove portion connected to both end portions of the connecting groove portion, and formed to surround a circumference of the second opening portion along with the connecting groove portion.

The sealant filling groove may further include a bypass groove portion configured to connect between an arbitrary point on the connecting groove portion and an arbitrary point on the first groove portion. The bypass groove portion may be located within a space formed by the connecting groove portion and the first groove portion.

The body may include a door accommodation portion recessed in an inward direction on an outer surface thereof to have the laundry inlet therewithin, and when the door is closed, the door may be accommodated into the door accommodation portion, and an edge portion of the outer surface of the door cover may form the same plane as that of an outer surface of the body adjacent thereto.

A laundry treating apparatus may include a body provided with a laundry inlet; and a door configured to open and close the laundry inlet, wherein the door includes a door frame having a first opening portion facing the laundry inlet inside when the door is closed and a second opening portion corresponding to a display module mounted at an inside; and a door cover coupled to the door frame to cover the first and the second opening portion so as to form an appearance of the door, and a sealant filling groove configured to fill sealant to adhere to the door cover, and formed to surround the first and the second opening portion, respectively, may be formed on the door frame.

The sealant filling groove may include a connecting groove portion formed to cross between the first and the second opening portion; a first groove portion connected to both end portions of the connecting groove portion, and formed to surround a circumference of the first opening portion along with the connecting groove portion; and a second groove portion connected to both end portions of the connecting groove portion, and formed to surround a circumference of the second opening portion along with the connecting groove portion.

The sealant filling groove may further include a first sealant collecting portion formed to surround the first opening portion in an inner space formed by the connecting groove portion and the first groove portion; a second sealant collecting portion formed to surround the second opening portion in an inner space formed by the connecting groove portion and the second groove portion; and a third sealant collecting portion formed to surround the first groove portion and the second groove portion.

A laundry treating apparatus may include a body provided with a laundry inlet; and a door configured to open and close the laundry inlet, wherein the door includes a door frame configured to relatively move with respect to the body; a door cover coupled to the door frame to form an appearance of the door, and configured to have a non-light-transmitting region and a light transmitting region within the non-light-transmitting region; and a display module provided on a rear

surface of the door cover to display visual information through the light transmitting region, and the light transmitting region is formed with a smaller size than that of the display module, and disposed to overlap within the display module when the door cover is coupled to the door frame.

The display module may be formed in a rectangular shape, and the light transmitting region may be formed in a circular shape disposed to overlap with part of the display module, and the non-light-transmitting region may cover another part of the display module that does not overlap with the light transmitting region. Visual information may not be displayed on another part of the display module. A touch sensor covering the light transmitting region and part of the non-light-transmitting region around the light transmitting region may be adhered to a rear surface of the door cover.

A laundry treating apparatus may include a body provided with a laundry inlet; and a door configured to open and close the laundry inlet, wherein the door includes a door cover configured to form an appearance of the door, and configured to have a first edge portion formed in a round manner and a second edge portion for connecting both sides of the first edge portion; and a door frame configured to relatively move with respect to the body, and on which a mounting guide configured to surround an outer circumference of the door cover is formed in a protruding manner along a circumference thereof, and the mounting guide includes a first protrusion portion extended in a round manner to correspond to the first edge portion; and a second protrusion portion formed to correspond to the second edge portion to guide a mounting position when the door cover is mounted on the door frame. The second protrusion portion may be formed at a lower side of the door frame.

A laundry treating apparatus may include a body provided with a laundry inlet; and a door configured to open and close the laundry inlet, wherein the door includes a door cover configured to form an appearance of the door, and configured to have a non-light-transmitting region and a light transmitting region within the non-light-transmitting region; a display module provided on a rear surface of the door cover to display visual information through the light transmitting region; and a door frame configured to have a display module accommodation portion to accommodate the display module and an opening portion facing the laundry inlet in a state that the door is closed, and formed with a sealant filling groove configured to fill sealant for adhesion to the door cover on a front surface thereof.

The sealant filling groove may include a connecting groove portion formed to cross between the display module accommodation portion and the opening portion; a first groove portion connected to both end portions of the connecting groove portion, and formed to surround a circumference of the opening portion along with the connecting groove portion; and a second groove portion connected to both end portions of the connecting groove portion, and formed to surround a circumference of the display module accommodation portion along with the connecting groove portion.

The sealant filling groove may further include a bypass groove portion configured to connect between an arbitrary point on the connecting groove portion and an arbitrary point on the first groove portion within a space formed by the connecting groove portion and the first groove portion. The sealant filling groove may include a sealant coating portion for filling sealant; and a sealant collecting portion formed at both sides of the sealant coating portion to collect sealant leaked out of an inner and an outer side of the sealant coating portion, respectively.

A laundry treating apparatus may include a body provided with a laundry inlet; and a door configured to open and close the laundry inlet, wherein the door may include a door frame; a door cover mounted at one side of the door frame, and provided with a light transmitting region; a mounting frame mounted at the other side of the door frame; a display mounted on the mounting frame to display visual information through the light transmitting region of the door cover; and a display sealing member disposed between the door frame and the mounting frame, and formed to surround the display.

An accommodation groove formed to accommodate part of the display sealing member and surround the display may be formed on the mounting frame. Another part of the display sealing member may be formed to be protruded from the accommodation groove, and brought into contact with the door frame when the mounting frame is mounted on the door frame. The display sealing member may be provided with a plurality of contact portions brought into contact with the door frame, respectively, and the plurality of contact portions may be disposed to be separated from each other in a width direction, and extended in parallel along a length direction to form a plurality of sealing loops.

The laundry treating apparatus may further include a display cover formed of a light transmitting material, and arranged to cover the display; and a filler configured to fill a gap between the mounting frame and the door cover. The door frame may include an outer frame formed with a sealant filling groove to fill sealant to adhere to the door cover on a front surface; and an inner frame coupled to a rear side of the outer frame, and arranged to cover the mounting frame.

A circumferential portion of the inner frame may form a mounting guide protruded from a front surface of the outer frame to surround an outer circumference of the door cover. A communication portion configured to communicate with an inner space formed by the outer frame and the inner frame may be formed on the inner frame, and a frame cover configured to open and close the communication portion may be detachably coupled to the inner frame.

The laundry treating apparatus may further include a touch sensor adhered to a rear surface of the door cover to sense a touch input to the light transmitting region. A display hole corresponding to the display and a communication hole passing through a flexible printed circuit board (FPCB) of the touch sensor may be formed on the door frame, and the display sealing member may be formed to surround the display hole and the communication hole.

The display may be mounted at one side of the mounting frame, and a printed circuit board (PCB) electrically connected to the display and the flexible printed circuit board may be mounted at the other side thereof. A wireless communication module capable of performing wireless communication with an external electronic device may be further mounted at the other side of the mounting frame.

The laundry treating apparatus may further include a PCB cover mounted on the mounting frame and arranged to cover the printed circuit board; and a PCB sealing member provided between the mounting frame and the PCB cover and formed to surround the printed circuit board. The PCB sealing member may be formed to surround the FPCB hole. A mounting groove configured to accommodate part of the PCB sealing member, and formed to surround the printed circuit board may be formed on the mounting frame.

Another part of the PCB sealing member may be formed to be protruded from the mounting groove, and brought into contact with the PCB cover when the PCB cover is mounted

on the mounting frame. The PCB sealing member may be provided with a plurality of contact portions brought into contact with the PCB cover, respectively, and the plurality of contact portions may be disposed to be separated from each other in a width direction, and extended in parallel along a length direction to form a plurality of sealing loops.

A laundry treating apparatus may include a body provided with a laundry inlet; and a door configured to open and close the laundry inlet, wherein the door includes a door frame configured to relatively move with respect to the body; a door cover coupled to the door frame to form an appearance of the door; and a display module provided on a rear surface of the door cover, and the display module includes a mounting frame provided with a display mounting portion and a printed circuit board mounting portion at both side thereof, respectively; a PCB cover mounted on the mounting frame to cover the printed circuit board mounting portion; a display sealing member provided between the door frame and the mounting frame, and formed to surround the display mounting portion; and a PCB sealing member provided between the mounting frame and the PCB cover, and formed to surround the printed circuit board mounting portion.

The display sealing member may be provided with a plurality of contact portions brought into contact with the mounting frame, respectively, and the plurality of contact portions may be separated from each other in a width direction, and extended in parallel along a length direction to form a plurality of sealing loops. The PCB sealing member may have a plurality of contact portions brought into contact with the PCB cover, respectively, and the plurality of contact portions may be separated from each other in a width direction, and extended in parallel along a length direction to form a plurality of sealing loops.

A non-light-transmitting region and a first and a second light transmitting region divided from each other within the non-light-transmitting region may be formed on a door cover, and a window unit (or window) and a display unit (or touch screen) may be formed in the first and the second light transmitting region, respectively, to implement a simple door appearance. In particular, when the first and the second light transmitting region are formed in a circular shape to correspond to a circular shaped door, it may be possible to give an integrated aesthetic sense to the user.

Moreover, the second light transmitting region may be formed in a circular shape overlapping within a rectangular display, and visual information may be displayed only on a portion corresponding to the circular shaped second light transmitting region, thereby providing a circular shaped display unit to the user. Here, the controller may control the display of visual information to a portion that does not correspond to the second light transmitting region within the display, thereby reducing power.

A mounting guide of the door frame may be configured with a first protrusion portion in a round shape and a second protrusion portion in a linear shape corresponding to a first and a second edge portion of the door, respectively, and thus the door cover may be a reference point capable of adjusting an installation position between the second edge portion and the second protrusion portion when the door cover is assembled to the door frame. In other words, when the second edge portion corresponds to the second protrusion portion, the door cover may be located at a normal position on the door frame, and thus the first and the second light transmitting region of the door cover may correspond to the first and the second opening portion of the door frame.

Even though sealant filled into the sealant coating portion is leaked out during the process of coupling the door cover

to the outer frame, it is configured to collect sealant leaked into the sealant collecting portion provided at an inner and an outer side of the sealant coating portion, respectively. As a result, it may be possible to prevent the deterioration of appearance quality due to the leakage of sealant.

Furthermore, the sealant coating portion may be adjacent to an edge portion of the outer frame. Accordingly, it may be possible to minimize a non-joint portion on an edge portion of the corresponding door cover, thereby enhancing the joint strength, and effectively preventing foreign substances from leaking through a gap between the door cover and the outer frame.

A display sealing member may be provided between the door frame and the mounting frame, thus having a structure capable of preventing moisture from being infiltrated into a flexible printed circuit board between the display and the touch screen provided therein. Here, a filler may be filled into a gap between the mounting frame and the door cover, and in this case, it may be possible to prevent moisture from being infiltrated into the display once more.

Furthermore, a PCB sealing member may be provided between the mounting frame and the PCB cover, thus having a structure capable of preventing moisture from leaking into the printed circuit board and wireless communication module. The display sealing member and PCB sealing member may include a plurality of contact portions separated from each other in a width direction, and extending in parallel along a length direction to form a plurality of sealing loops. In this case, a sealing loop formed by any one contact portion may be located within a sealing loop formed by another contact portion, thereby enhancing the reliability of the sealing structure.

Any reference in this specification to “one embodiment,” “an embodiment,” “example embodiment,” etc., means that a particular feature, structure, or characteristic described in connection with the embodiment is included in at least one embodiment. The appearances of such phrases in various places in the specification are not necessarily all referring to the same embodiment. Further, when a particular feature, structure, or characteristic is described in connection with any embodiment, it is submitted that it is within the purview of one skilled in the art to effect such feature, structure, or characteristic in connection with other ones of the embodiments.

Although embodiments have been described with reference to a number of illustrative embodiments thereof, it should be understood that numerous other modifications and embodiments can be devised by those skilled in the art that will fall within the spirit and scope of the principles of this disclosure. More particularly, various variations and modifications are possible in the component parts and/or arrangements of the subject combination arrangement within the scope of the disclosure, the drawings and the appended claims. In addition to variations and modifications in the component parts and/or arrangements, alternative uses will also be apparent to those skilled in the art.

What is claimed is:

[1. A laundry treating apparatus, comprising:

a body having a laundry inlet and a laundry accommodation part accommodating laundry through the laundry inlet; and

a circular door configured to open or close the laundry inlet, wherein the door includes:

a door frame having a first opening facing the laundry inlet when the door is closed and a second opening formed in a position spaced apart from the first opening;

27

a door window mounted at the first opening and disposed to correspond to the laundry inlet when the door is closed;

a display module mounted at the second opening within the door frame to output visual information through the second opening; and

a door cover coupled to a front side of the door frame to form an appearance of the door, wherein the door cover includes a non-light-transmitting region, and a first light transmitting region corresponding to the first opening and a second light transmitting region corresponding to the second opening within the non-light-transmitting region, the non-light-transmitting region surrounds both the first light transmitting region and the second light transmitting region to compartment the first light transmitting region allowing the laundry accommodation part to be visible and the second light transmitting region allowing visual information output from the display module to be visible, and a mounting guide guiding alignment of the first opening and the first light transmitting region and alignment of the second opening and the second light transmitting region is provided on at least one of the door frame and the door cover when the door frame and the door cover are coupled to each other to limit a coupling position of the door cover with respect to the door frame.]

[2. The laundry treating apparatus of claim 1, wherein the mounting guide protrudes along a circumference of the door frame, and surrounds an outer circumference of the door cover.]

[3. The laundry treating apparatus of claim 2, wherein the door cover includes a first edge portion having a predetermined curvature and a second edge portion that connects a first end and a second end of the first edge portion, and wherein the mounting guide includes a first protrusion portion corresponding to the first edge portion and a second protrusion portion corresponding to the second edge portion to guide a mounting position when the door cover is mounted on the door frame.]

[4. The laundry treating apparatus of claim 3, wherein the second protrusion portion is formed at a lower side of the door frame.]

[5. The laundry treating apparatus of claim 2, wherein the door frame includes:

an outer frame having a sealant filling groove configured to receive sealant to adhere a front surface of the outer frame to the door cover; and

an inner frame coupled to a rear side of the outer frame, and formed such that an outer circumferential portion of the inner frame protrudes from a front surface of the outer frame to form the mounting guide when coupled to the outer frame.]

[6. The laundry treating apparatus of claim 1, wherein the mounting guide protrudes along a rear circumference of the door cover, and is positioned along an outer circumference of the door frame.]

[7. The laundry treating apparatus of claim 6, wherein the door frame is accommodated into a space formed by the mounting guide.]

[8. The laundry treating apparatus of claim 6, wherein the door frame includes a first edge portion having a predetermined curvature and a second edge portion that connects a first end and a second end of the first edge portion, and wherein the mounting guide includes a first protrusion portion corresponding to the first edge portion and a second

28

protrusion portion corresponding to the second edge portion to guide an installation position when the door frame is mounted on the door cover.]

[9. The laundry treating apparatus of claim 8, wherein a front surface of the door cover formed with the second protrusion portion has the same radius of curvature as that of a front surface of the door cover formed with the first protrusion portion.]

[10. The laundry treating apparatus of claim 1, wherein the mounting guide includes:

an alignment groove formed at either one of the door frame and the door cover; and

an alignment protrusion protruding from the other one of the door frame and the door cover, and configured to be inserted into the alignment groove during mutual coupling between the door frame and the door cover.]

[11. The laundry treating apparatus of claim 10, wherein the alignment groove and the alignment protrusion are formed within the non-light-transmitting region.]

[12. The laundry treating apparatus of claim 11, wherein a plurality of alignment protrusions are provided and protrude at a plurality of positions.]

[13. The laundry treating apparatus of claim 11, wherein the alignment protrusion extends along at least one direction.]

14. *A laundry treating apparatus, comprising:*

a body having a laundry inlet; and

a door configured to open or close the laundry inlet, wherein the door includes:

a door frame having a first opening facing the laundry inlet when the door is closed,

a door window mounted on the door frame to close the first opening and disposed to correspond to the laundry inlet when the door is closed, and

a door cover coupled to a front side of the door frame to form an appearance of the door,

wherein the door cover includes a non-light transmitting region and a first light transmitting region, and the first light transmitting region overlaps the door window so as to allow the door window to be visible,

wherein an adhesive is provided at the door frame for adhesion to the door cover, the adhesive comprising a first region extended along an inner circumference of the door frame, and a second region extended to cross an inside of the first region, and wherein the non-light transmitting region overlaps the adhesive so that the adhesive is not visible.

15. *The laundry treating apparatus of claim 14, wherein the first region extends along an inner circumference of the door frame.*

16. *The laundry treating apparatus of claim 14, wherein the first region extends in loop shape to surround the first opening.*

17. *The laundry treating apparatus of claim 16, wherein the non-light transmitting region surrounds the first light transmitting region to overlap the adhesive.*

18. *The laundry treating apparatus of claim 14, wherein the non-light transmitting region covers a contact area of the door window with the door frame so that the contact area is not visible.*

19. *The laundry treating apparatus of claim 18, wherein the second region extends in a linear shape to cross an inside of the first region.*

20. *The laundry treating apparatus of claim 19, wherein the first opening is surrounded by the second region and a portion of the first region.*

21. The laundry treating apparatus of claim 19, wherein the adhesive further includes a bypass region connected to the second region and the first region, and wherein the bypass region is spaced apart from points at which the second region and the first region contact each other. 5
22. The laundry treating apparatus of claim 14, wherein the front side of the door frame comprises:
 a first adhesion region to which the adhesive is provided and that extends along an inner circumference of the door frame; and 10
 a second adhesion region to which the adhesive is provided and that extends in a linear shape to cross an inside of the first adhesion region.
23. The laundry treating apparatus of claim 14, wherein the door cover is formed with a glass material and coupled to the door frame by the adhesive. 15
24. The laundry treating apparatus of claim 23, wherein a mounting guide is extended in a loop shape along a circumference of the door frame to form a space that accommodates the door cover. 20
25. The laundry treating apparatus of claim 24, wherein the adhesive extends along the mounting guide in the front side of the door frame.
26. The laundry treating apparatus of claim 24, wherein the mounting guide covers a lateral surface of the door cover, and 25
 wherein an upper surface of the mounting guide protrudes to a predetermined height.
27. The laundry treating apparatus of claim 14, wherein the door frame comprises: 30
 an outer frame to which the door cover is coupled; and
 an inner frame coupled to a rear side of the outer frame,
 wherein the adhesive is provided at the front side of the outer frame for adhesion to the door cover. 35
28. The laundry treating apparatus of claim 27, wherein the outer frame is coupled to the door cover by the adhesive.
29. The laundry treating apparatus of claim 28, wherein the adhesive corresponds to a sealant or a bonding member.

30. The laundry treating apparatus of claim 28, wherein the outer frame comprises an accommodation region located at the rear side of the outer frame to be coupled to the inner frame.
31. A laundry treating apparatus, comprising:
 a body having a laundry inlet; and
 a door configured to open or close the laundry inlet, wherein the door includes:
 a door frame having a first opening facing the laundry inlet when the door is closed,
 a door window mounted on the door frame to close the first opening and disposed to correspond to the laundry inlet when the door is closed, and
 a door cover coupled to a front side of the door frame to form an appearance of the door,
 wherein the door cover includes a non-light transmitting region and a first light transmitting region, and the first light transmitting region overlaps the door window so as to allow the door window to be visible,
 wherein the door frame comprises:
 an outer frame including the front side of the door frame; and
 an inner frame coupled to a rear side of the outer frame, and
 wherein an adhesive is provided to the outer frame, and the outer frame is coupled with the door cover by the adhesive, and
 wherein the adhesive comprises a first region extended along an inner circumference of the door frame and a second region extended to cross an inside of the first region, and
 wherein the non-light transmitting region overlaps the adhesive so that the adhesive is not visible.
32. The laundry treating apparatus of claim 31, wherein the non-light transmitting region covers a contact area of the door window with the door frame so that the contact area is not visible.

* * * * *