



US00RE50047E

(19) **United States**
(12) **Reissued Patent**
Ono

(10) **Patent Number:** **US RE50,047 E**
(45) **Date of Reissued Patent:** ***Jul. 16, 2024**

(54) **LUMINESCENT DISPLAY DEVICE**

(56) **References Cited**

(71) Applicant: **JOLED INC.**, Tokyo (JP)

U.S. PATENT DOCUMENTS

(72) Inventor: **Shinya Ono**, Osaka (JP)

6,509,688 B1 * 1/2003 Bae G09G 3/32
257/E27.111

(73) Assignee: **JDI DESIGN AND DEVELOPMENT G.K.**, Tokyo (JP)

6,599,786 B1 7/2003 Ahn et al.
(Continued)

(*) Notice: This patent is subject to a terminal disclaimer.

FOREIGN PATENT DOCUMENTS

(21) Appl. No.: **17/580,255**

JP 2005-340772 12/2005
JP 2005-340772 A 12/2005

(22) Filed: **Jan. 20, 2022**

(Continued)

Related U.S. Patent Documents

OTHER PUBLICATIONS

Reissue of:

Japan Office Action in Japanese Patent Appl. No. 2011-008286, mail date Nov. 5, 2013.

(64) Patent No.: **9,461,102**
Issued: **Oct. 4, 2016**
Appl. No.: **13/012,294**
Filed: **Jan. 24, 2011**

(Continued)

U.S. Applications:

Primary Examiner — Adam L Basehoar
(74) *Attorney, Agent, or Firm* — Greenblum & Bernstein, P.L.C.

(63) Continuation of application No. 16/671,675, filed on Nov. 1, 2019, now Pat. No. Re. 48,931, which is an
(Continued)

(57) **ABSTRACT**

(51) **Int. Cl.**
G09G 3/22 (2006.01)
G09G 3/32 (2016.01)
(Continued)

A luminescent display device includes a substrate and a thin-film transistor above the substrate. The thin-film transistor includes a semiconductor layer, a gate insulating film on the semiconductor layer, a gate electrode on the gate insulating film, a source electrode, and a drain electrode. The luminescent display device further includes an interlayer insulating film on the gate electrode, a first capacitor electrode on the interlayer insulating film in a region above the gate electrode, and a luminescent element configured to be driven by a driver to produce luminescence. The driver includes the thin-film transistor, and the first capacitor electrode and the gate electrode constitute a capacitor.

(52) **U.S. Cl.**
CPC **H10K 59/1216** (2023.02); **G09G 3/3233** (2013.01); **H01L 27/1255** (2013.01)

(58) **Field of Classification Search**
CPC H01L 27/1255; G09G 3/3233; H10K 59/1216

See application file for complete search history.

28 Claims, 14 Drawing Sheets

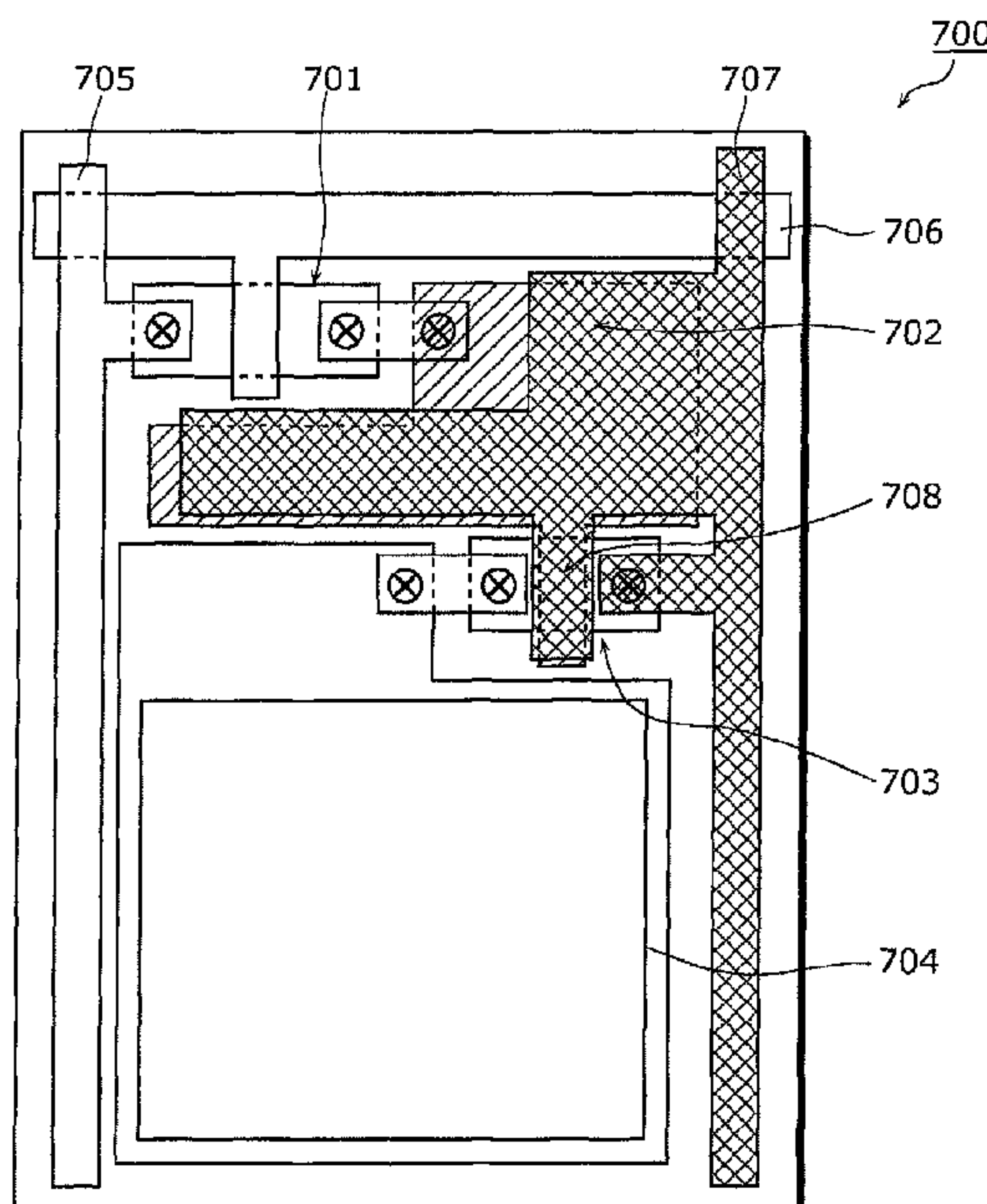

Related U.S. Application Data

application for the reissue of Pat. No. 9,461,102, and a continuation of application No. 16/145,623, filed on Sep. 28, 2018, now Pat. No. Re. 47,804, which is an application for the reissue of Pat. No. 9,461,102, which is a continuation of application No. PCT/JP2009/006415, filed on Nov. 27, 2009.

- (51) **Int. Cl.**
G09G 3/3233 (2016.01)
H01L 27/12 (2006.01)
H01L 27/32 (2006.01)
H10K 59/121 (2023.01)

| | | | |
|--------------|-----|---------|----------------------------|
| 2008/0017866 | A1 | 1/2008 | Sato |
| 2008/0099760 | A1 | 5/2008 | Fujimori et al. |
| 2008/0217624 | A1 | 9/2008 | Kwak et al. |
| 2008/0246403 | A1 | 10/2008 | Sagawa et al. |
| 2008/0309653 | A1 | 12/2008 | Takahashi et al. |
| 2009/0047775 | A1 | 2/2009 | Yamazaki et al. |
| 2010/0090205 | A1 | 4/2010 | Ofuji et al. |
| 2010/0224868 | A1 | 9/2010 | Udagawa et al. |
| 2010/0253710 | A1* | 10/2010 | Rankov et al. 345/690 |
| 2010/0295758 | A1 | 11/2010 | Kawabe |
| 2010/0302221 | A1 | 12/2010 | Okumoto |
| 2011/0068707 | A1 | 3/2011 | Kubota et al. |
| 2012/0199871 | A1 | 8/2012 | Kubota et al. |
| 2012/0299471 | A1 | 11/2012 | Yamazaki et al. |
| 2017/0141177 | A1 | 5/2017 | Kim et al. |

(56) **References Cited**

U.S. PATENT DOCUMENTS

| | | | |
|--------------|-----|---------|--------------------------|
| 7,378,739 | B2 | 5/2008 | Kwak et al. |
| 7,642,559 | B2 | 1/2010 | Yamazaki et al. |
| 7,652,291 | B2 | 1/2010 | Koo et al. |
| 7,671,368 | B2 | 3/2010 | Kwak et al. |
| 7,701,134 | B2 | 4/2010 | Yamazaki et al. |
| 7,723,721 | B2 | 5/2010 | Udagawa et al. |
| 7,741,775 | B2 | 6/2010 | Yamazaki et al. |
| 7,863,612 | B2 | 1/2011 | Sato |
| 7,872,264 | B2 | 1/2011 | Kubota et al. |
| 8,159,420 | B2 | 4/2012 | Takahashi et al. |
| 8,198,636 | B2 | 6/2012 | Kubota et al. |
| 8,227,809 | B2 | 7/2012 | Yamazaki et al. |
| 9,093,409 | B2 | 7/2015 | Ono |
| RE47,804 | E | 1/2020 | Ono |
| RE48,931 | E * | 2/2022 | Ono G09G 3/3233 |
| 2003/0089905 | A1 | 5/2003 | Udagawa et al. |
| 2003/0141811 | A1* | 7/2003 | Park et al. 313/506 |
| 2004/0065902 | A1 | 4/2004 | Yamazaki et al. |
| 2005/0161672 | A1 | 7/2005 | Yamazaki et al. |
| 2005/0258466 | A1 | 11/2005 | Kwak et al. |
| 2005/0275352 | A1* | 12/2005 | Sun 315/169.3 |
| 2006/0097256 | A1 | 5/2006 | Yamazaki et al. |
| 2006/0097966 | A1* | 5/2006 | Choi 345/77 |
| 2006/0192205 | A1 | 8/2006 | Yamazaki et al. |
| 2006/0267491 | A1 | 11/2006 | Koo et al. |
| 2007/0040772 | A1 | 2/2007 | Kim |
| 2008/0017860 | A1 | 1/2008 | Kubota et al. |

FOREIGN PATENT DOCUMENTS

| | | |
|----|---------------|---------|
| JP | 2006-330736 | 12/2006 |
| JP | 2006-330736 A | 12/2006 |
| JP | 2007-226184 | 9/2007 |
| JP | 2008-046619 | 2/2008 |
| JP | 2008-46619 A | 2/2008 |
| JP | 2008-107785 | 5/2008 |
| JP | 2008-112895 | 5/2008 |
| JP | 2008-235912 | 10/2008 |
| JP | 2008-235912 A | 10/2008 |
| JP | 2008-257086 | 10/2008 |
| JP | 2008-257086 A | 10/2008 |
| JP | 2009-071285 | 4/2009 |
| JP | 2009-139851 | 6/2009 |
| JP | 2009-157133 | 7/2009 |
| JP | 2009-200336 | 9/2009 |
| JP | 2009-200336 A | 9/2009 |
| JP | 2009-218223 | 9/2009 |
| JP | 2009-271188 | 11/2009 |

OTHER PUBLICATIONS

U.S.A. (U.S. Appl. No. 14/290,104) Office action, mail date Dec. 19, 2014.
 International Search Report in PCT/JP2009/006415, dated Dec. 22, 2009.
 Office Action in JP 2010-521255, dated Feb. 22, 2011.
 Japan Office Action mail date is Nov. 5, 2013.

* cited by examiner

PRIOR ART

FIG. 1

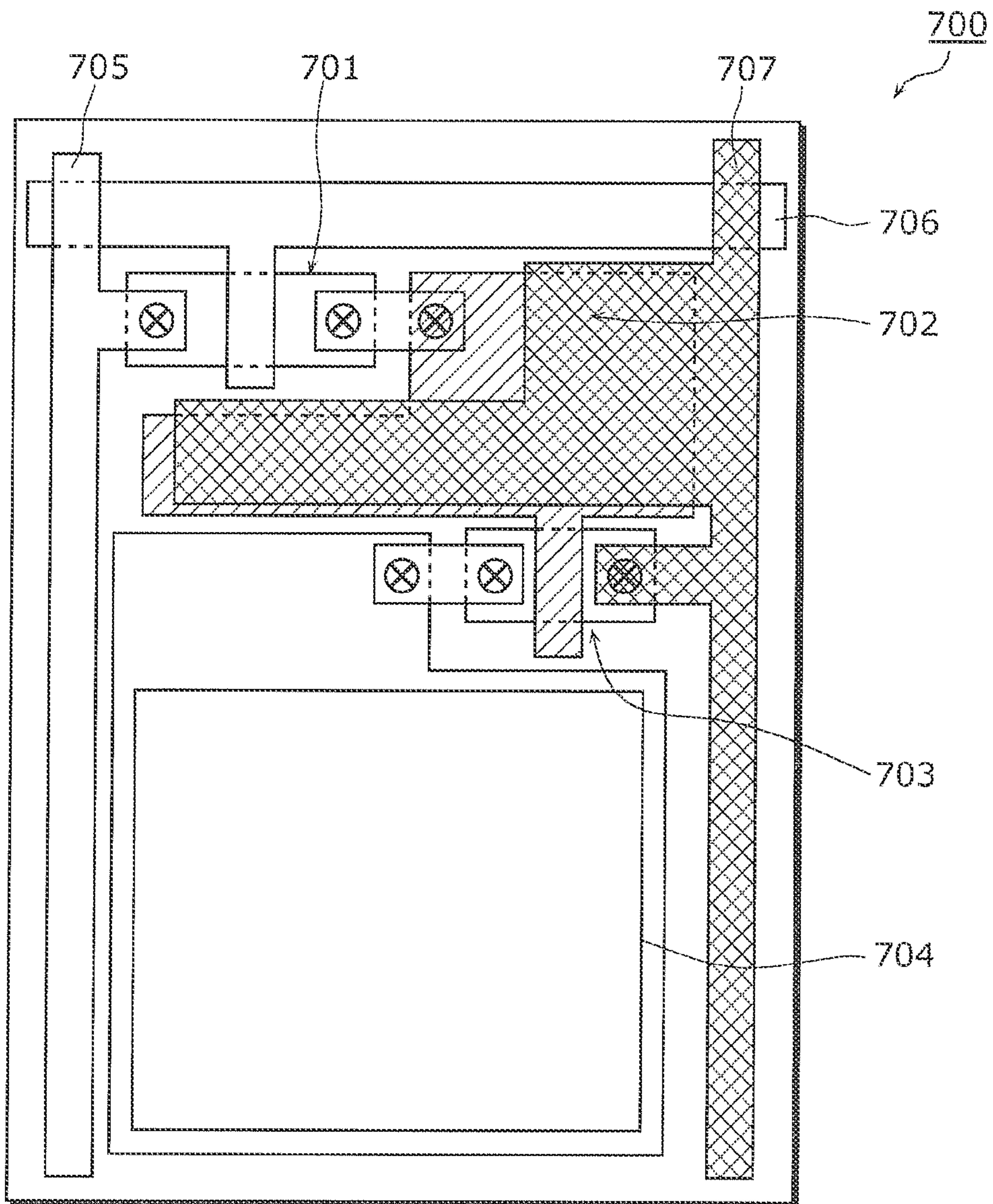

AMENDED

FIG. 2

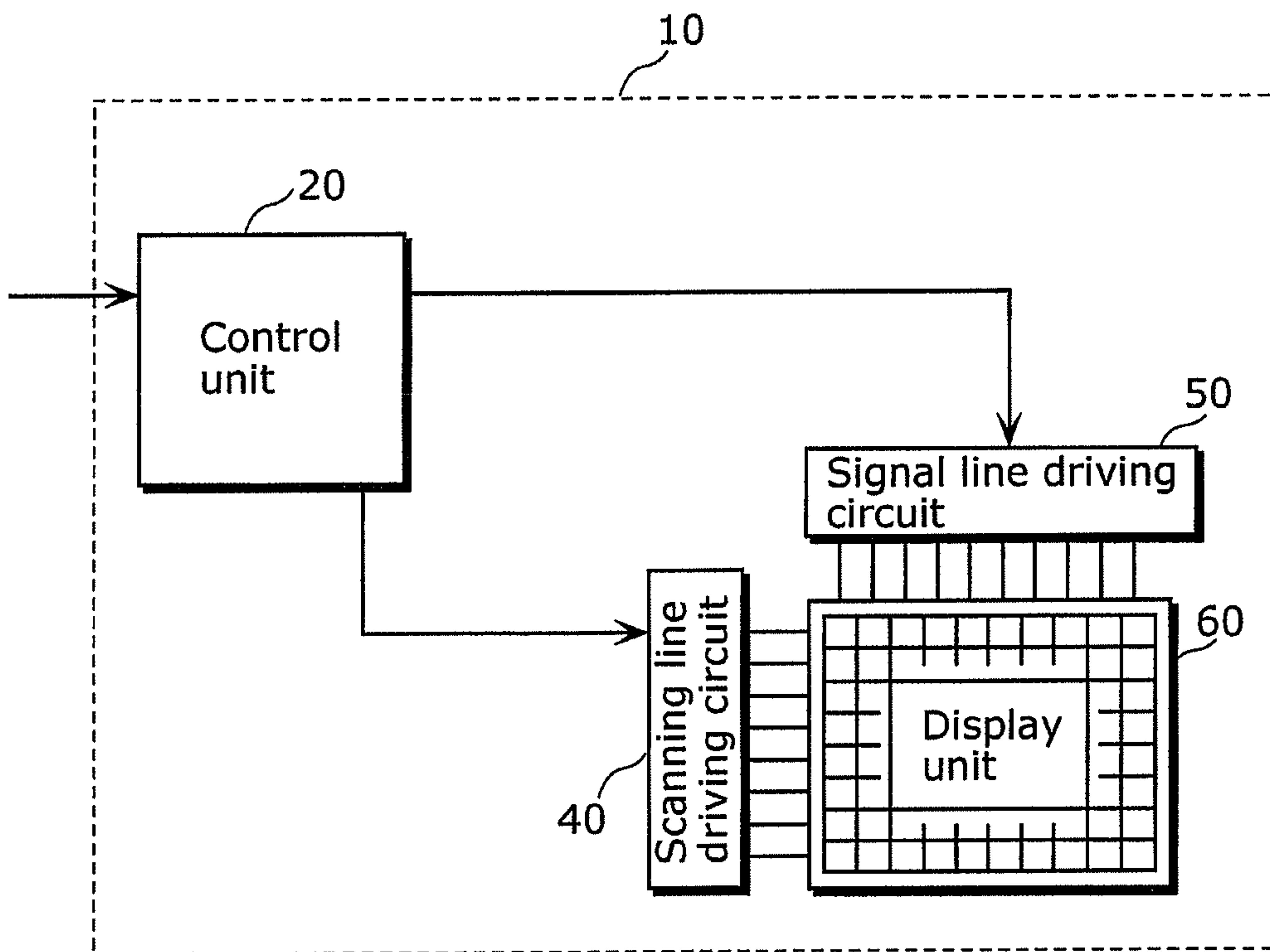

FIG. 3

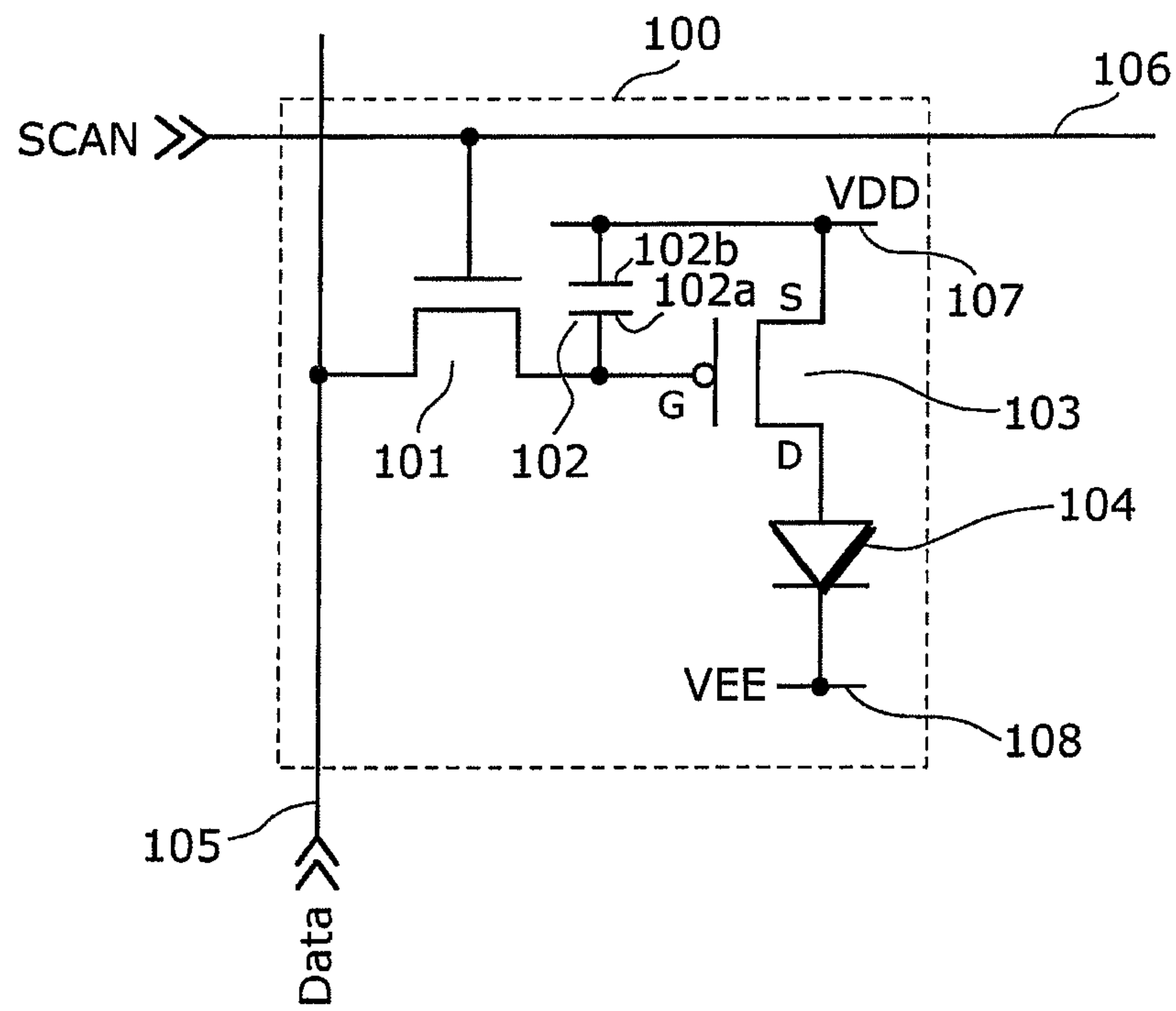

FIG. 4

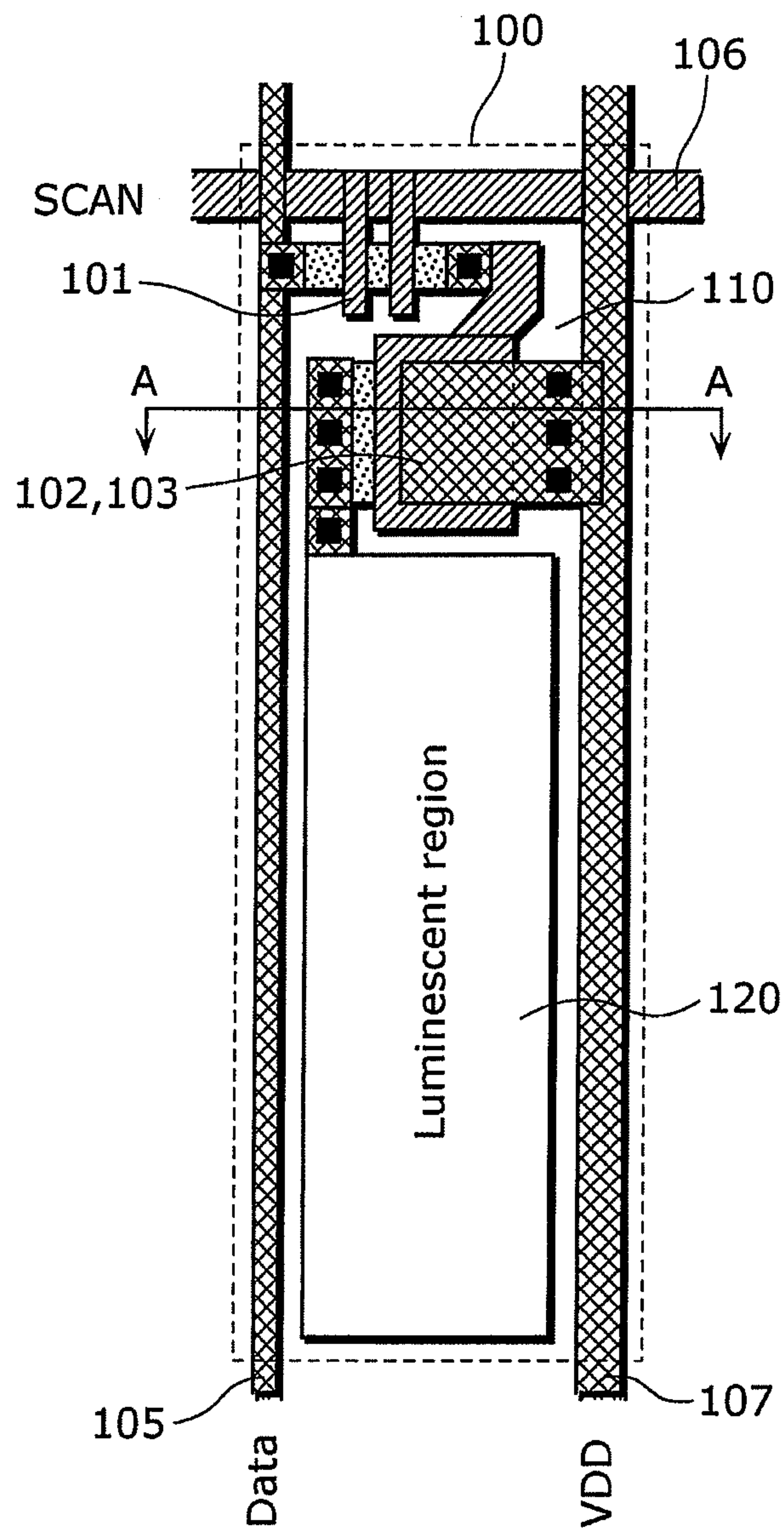

FIG. 5

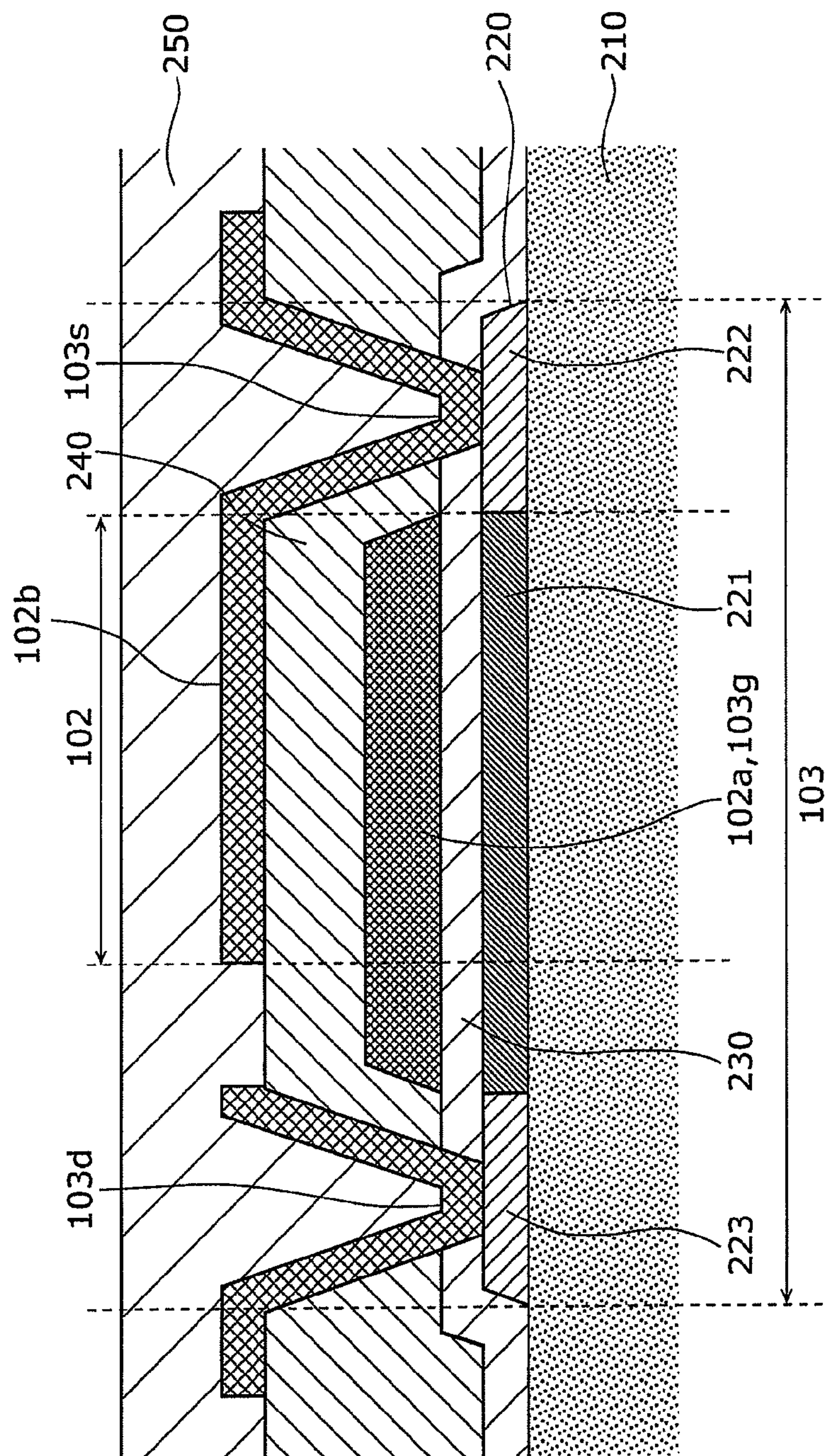

FIG. 6

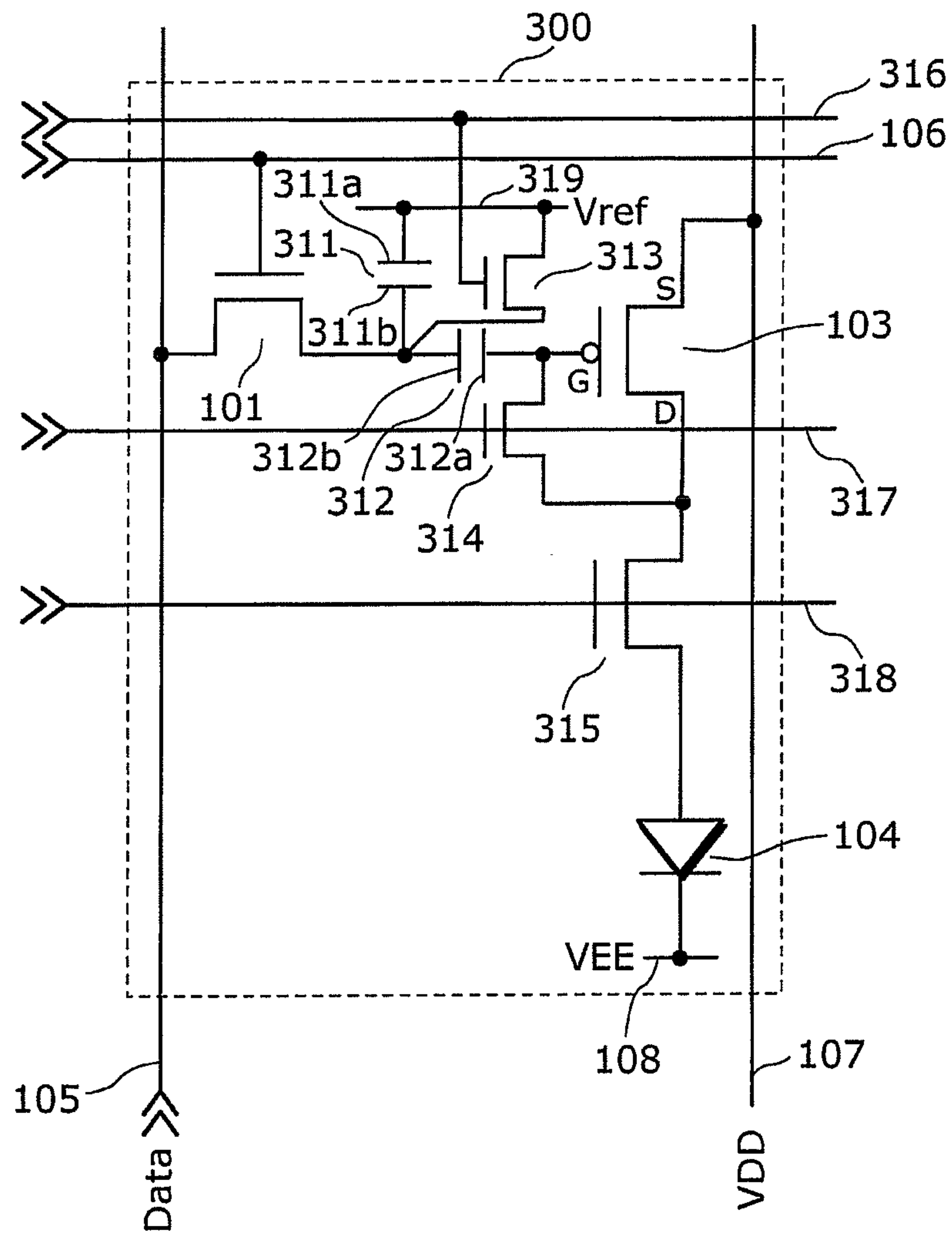

FIG. 7

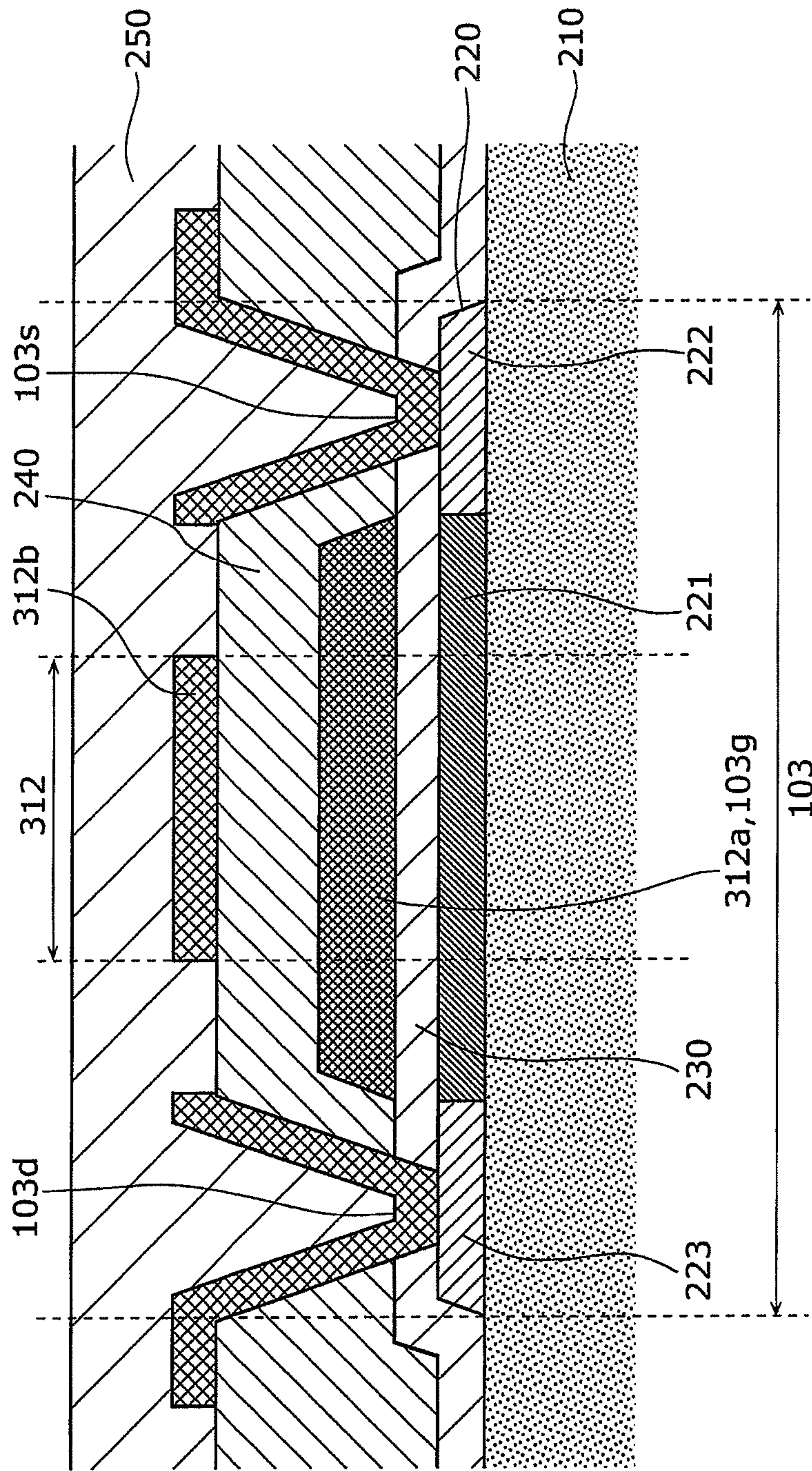

FIG. 8

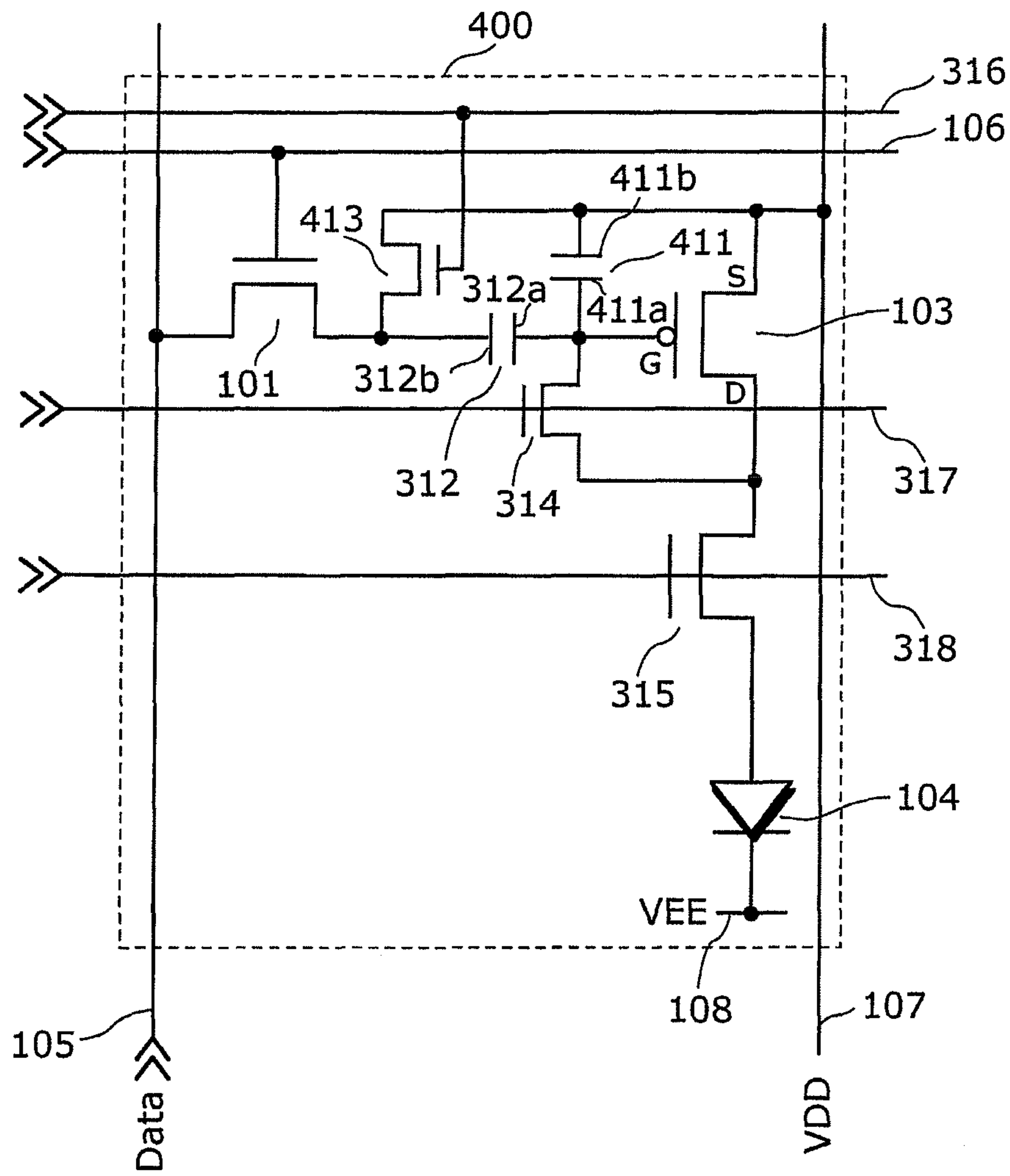

FIG. 9

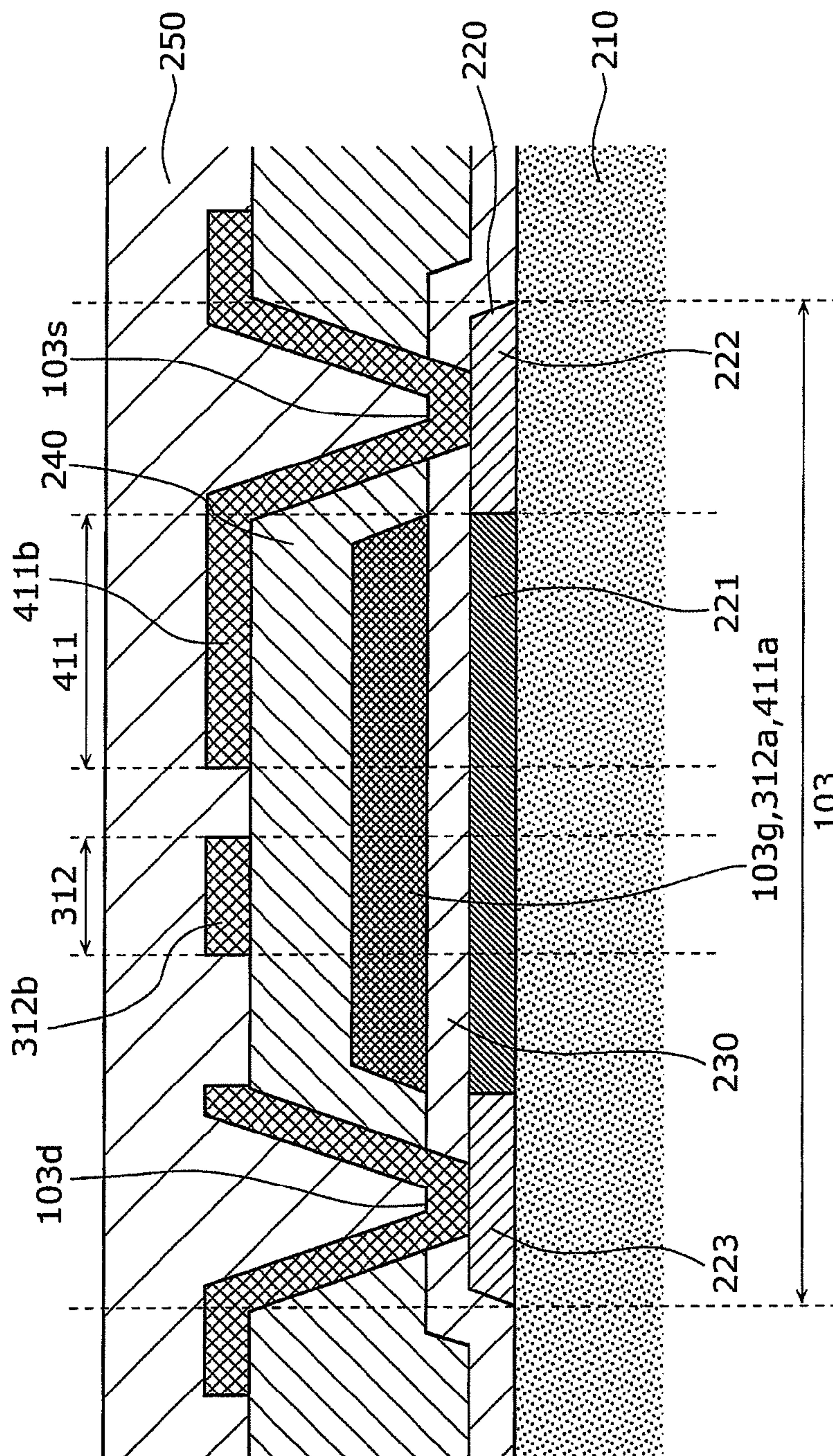

FIG. 10

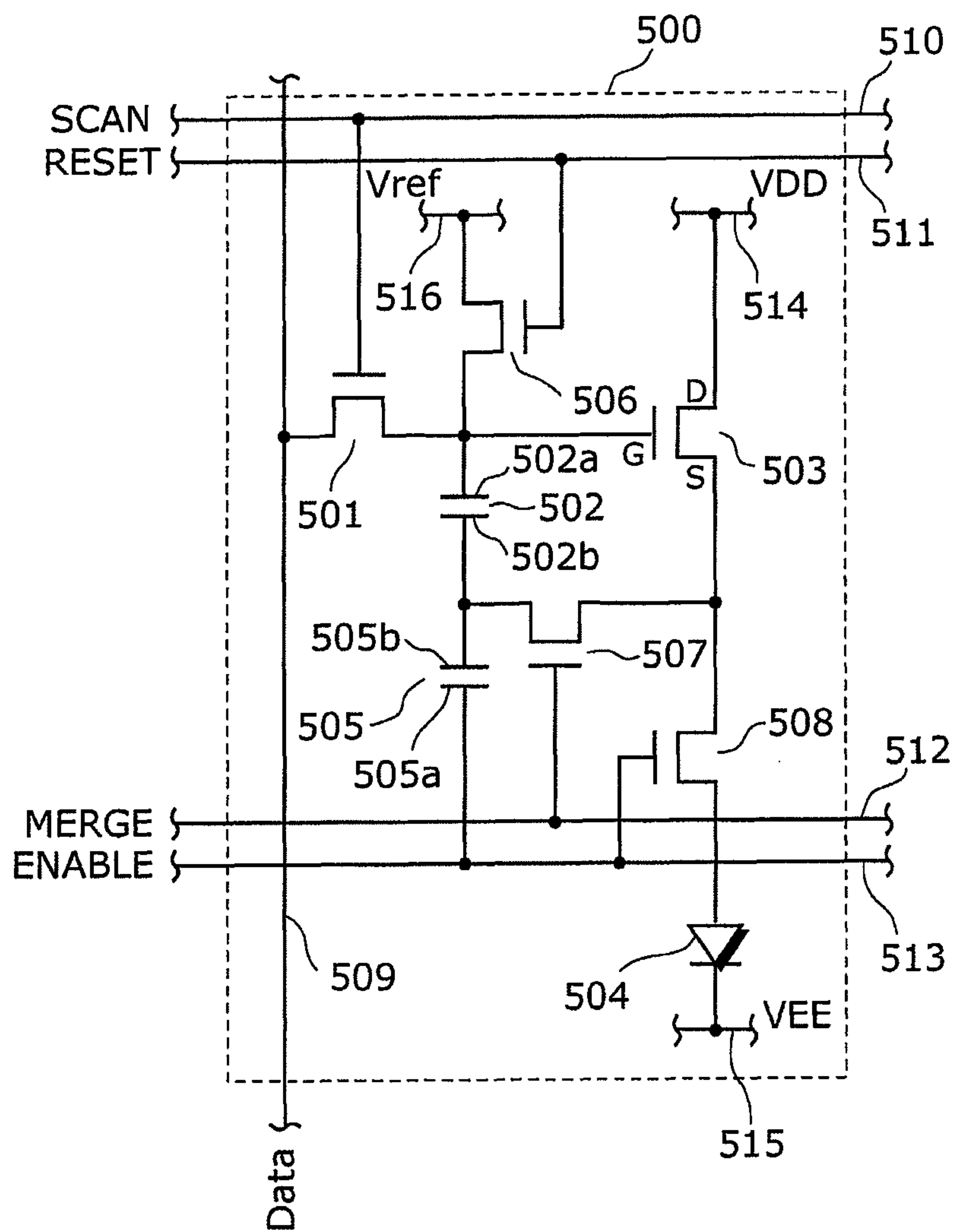
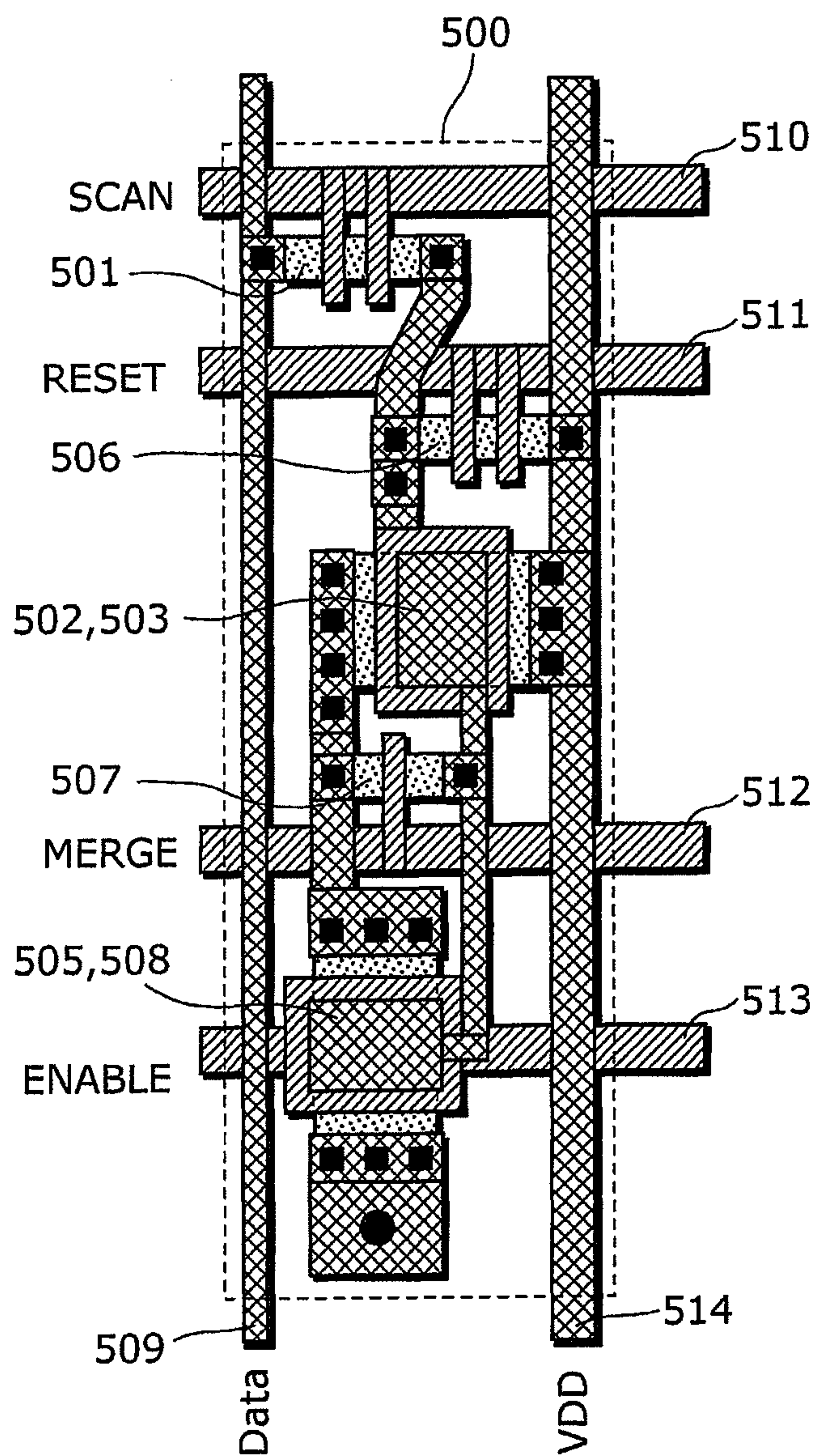

FIG. 11



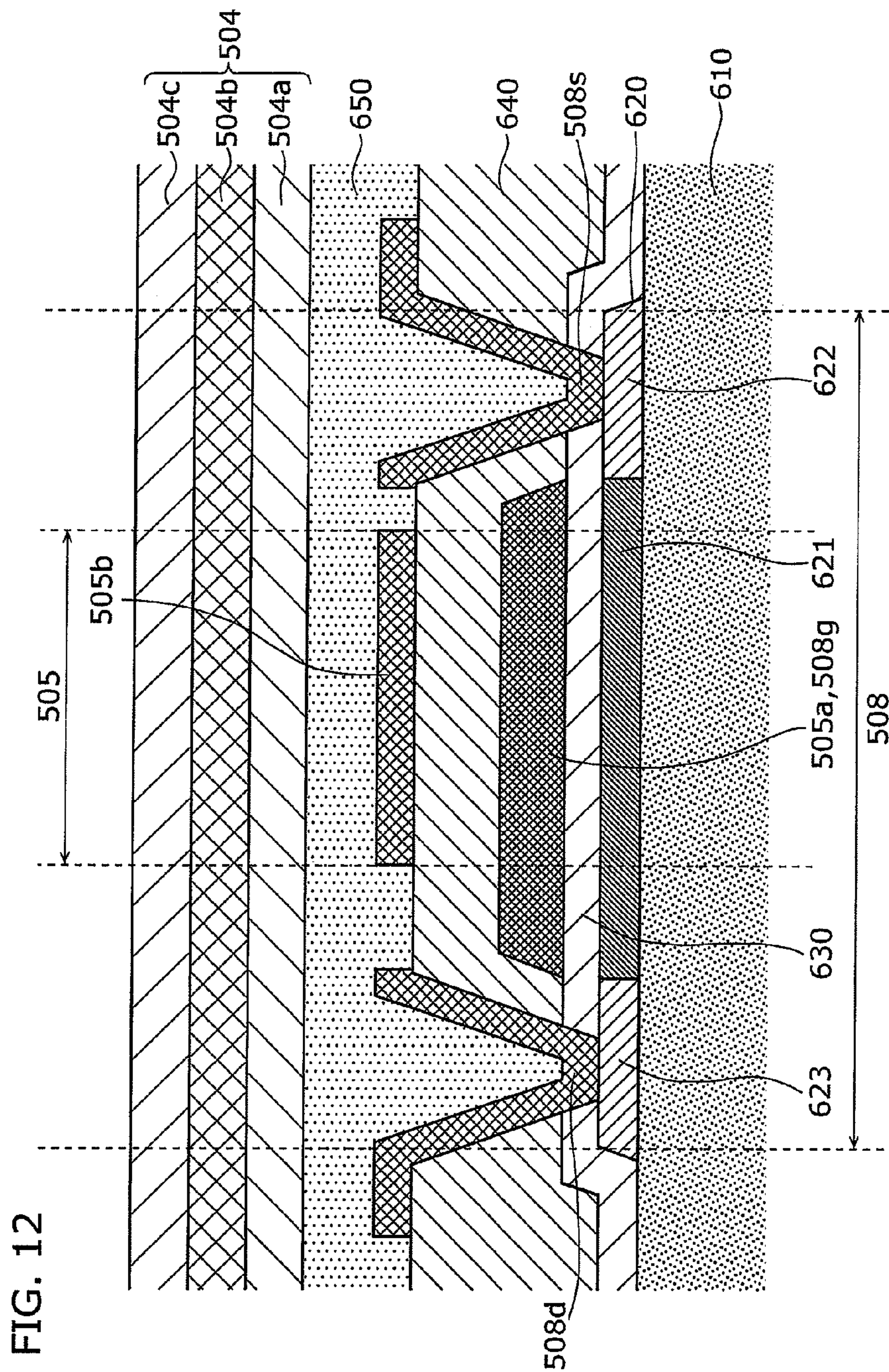

FIG. 13

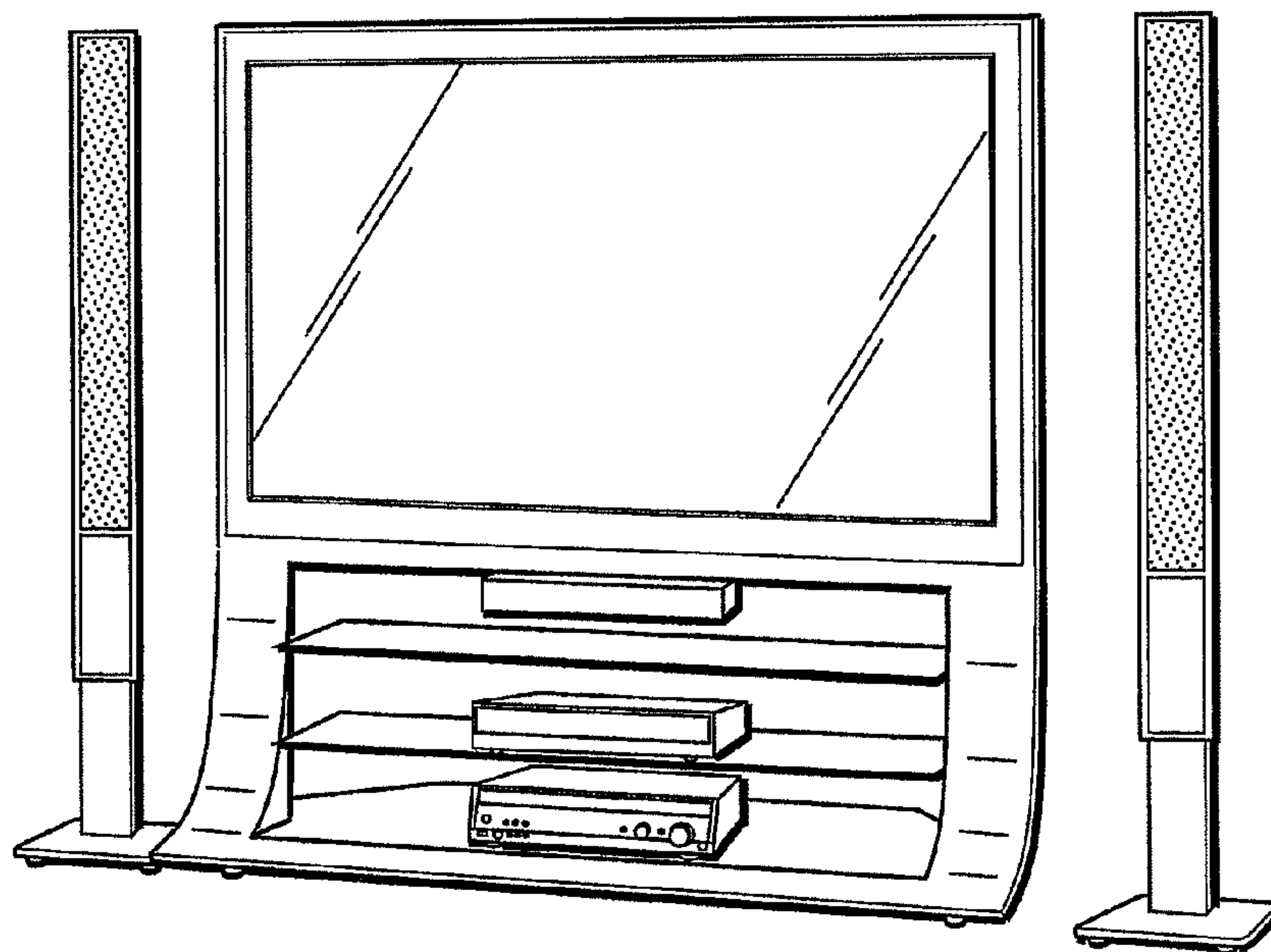
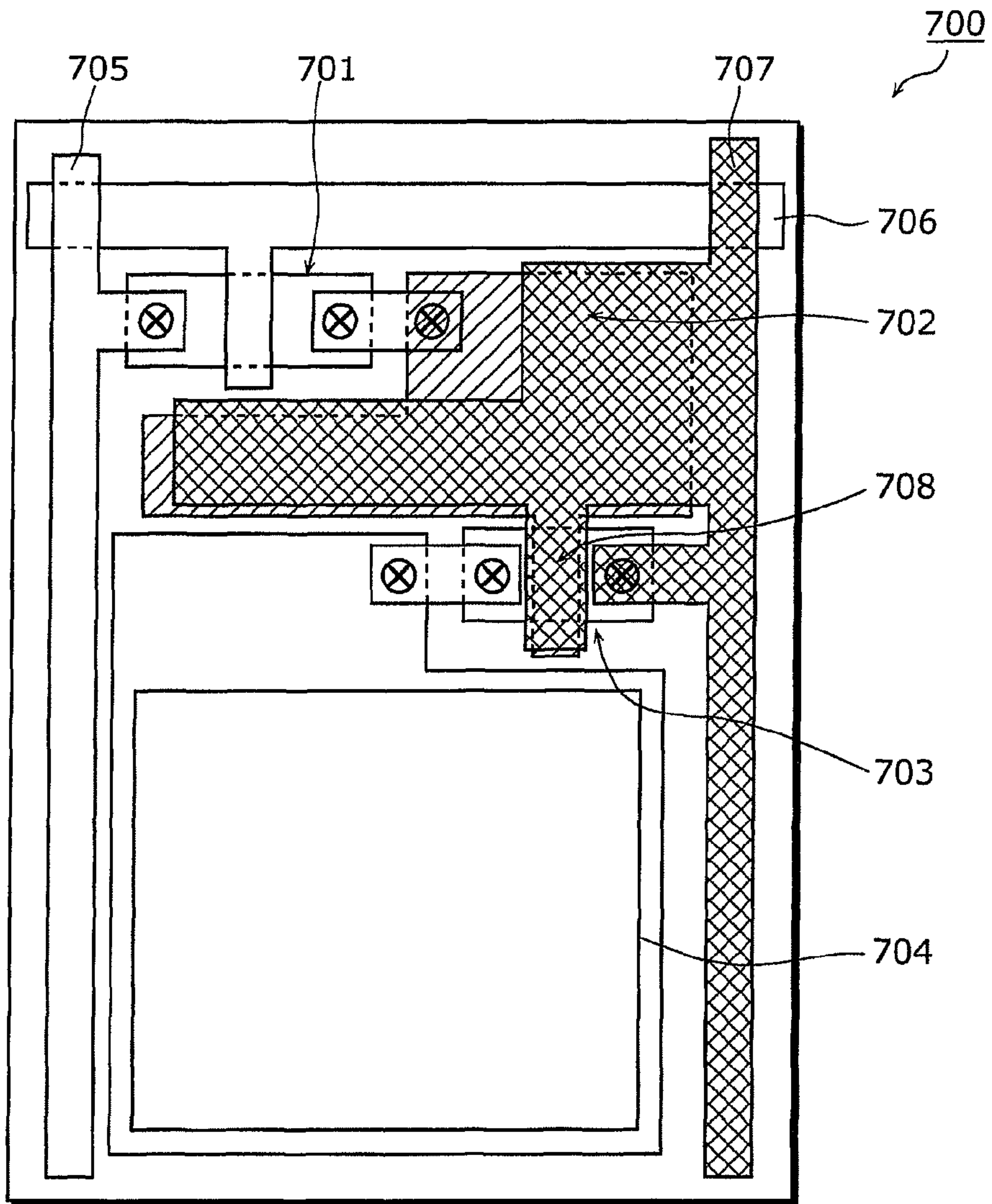

FIG. 14



LUMINESCENT DISPLAY DEVICE

Matter enclosed in heavy brackets [] appears in the original patent but forms no part of this reissue specification; matter printed in italics indicates the additions made by reissue; a claim printed with strikethrough indicates that the claim was canceled, disclaimed, or held invalid by a prior post-patent action or proceeding.

NOTICE: More than one reissue application has been filed for the reissue of U.S. Pat. No. 9,461,102 B2. Reissue application Ser. No. 16/145,623 is a reissue of U.S. Pat. No. 9,461,102 B2, was filed on Sep. 28, 2018, and issued as U.S. Pat. No. RE47,804 on Jan. 7, 2020. Reissue application Ser. No. 16/671,675 is a reissue of U.S. Pat. No. 9,461,102 B2, is a continuation reissue application of Reissue application Ser. No. 16/145,623, and was filed on Nov. 1, 2019. The present application is a reissue of U.S. Pat. No. 9,461,102 B2 and is a continuation reissue application of Reissue application Ser. No. 16/671,675.

CROSS REFERENCE TO RELATED APPLICATION

[This] *U.S. patent application Ser. No. 13/012,294, which issued as U.S. Pat. No. 9,461,102 B2, is a continuation application of PCT Application No. PCT/JP2009/006415, filed on Nov. 27, 2009, designating the United States of America. Reissue application Ser. No. 16/145,623 is a reissue of U.S. Pat. No. 9,461,102 B2, was filed on Sept. 28, 2018, and issued as U.S. Pat. No. RE47,804 on Jan. 7, 2020. Reissue application Ser. No. 16/671,675 is a reissue of U.S. Pat. No. 9,461,102 B2, is a continuation reissue application of Reissue application Ser. No. 16/145,623, and was filed on Nov. 1, 2019. The present application is a Reissue Application of U.S. Pat. No. 9,461,102 B2, [the] and is a continuation reissue application of Reissue application Ser. No. 16/671,675. The disclosure of [which] each of the above-identified documents, including the specification, drawings, and claims, is incorporated herein by reference in its entirety.*

BACKGROUND OF THE INVENTION

1. Field of the Invention

The present invention relates to luminescent display devices, and particularly to an active-matrix luminescent display device which includes a luminescent element and a driving circuit having a capacitor and a thin-film transistor.

2. Description of the Related Art

Conventionally, there is an active development of luminescent display devices, such as organic electroluminescent elements (hereinafter abbreviated as organic EL elements), in which luminescent elements that control the luminance using an electric current are two-dimensionally arranged. In particular, there is an ongoing development of active-matrix luminescent display devices in which pixel circuits are arranged which include, for each luminescent element, a driving circuit for driving the luminescent element.

The driving circuit generally includes: a switching transistor which selects a pixel for producing luminescence; a driving transistor which drives a luminescent element; and a capacitor. The driving circuit includes, for example, a capacitor which holds a voltage for determining an amount

of a current passed by the driving transistor (see Patent Literature 1: Japanese Unexamined Patent Application Publication No. 2006-330736).

FIG. 1 shows the layout of a luminescent pixel 700 included in a conventional luminescent display device disclosed in Patent Literature 1. As shown in FIG. 1, the luminescent pixel 700 is wired with a signal line 705, a scanning line 706, and a power line 707. Further, the luminescent pixel 700 includes a switching transistor 701, a capacitor 702, a driving transistor 703, and a luminescent element 704. The luminescent element 704 is formed in the luminescent region of the luminescent pixel 700, whereas the switching transistor 701, the capacitor 702, and the driving transistor 703 are formed in the driving circuit region.

SUMMARY OF THE INVENTION

With the above conventional technique, however, a region dedicated to the capacitor is formed, thereby causing a problem that when the number of capacitors or the capacitor area increases, the region for forming other elements becomes smaller, resulting in less design flexibility.

For example, as in the luminescent display device of Patent Literature 1 shown in FIG. 1, most of the driving circuit region is occupied by the capacitor 702. Therefore, in the case of forming a capacitor 702 which occupies a larger area or in the case of forming another capacitor, the region for forming the driving transistor 703 and the switching transistor 701 becomes smaller. Alternatively, the luminescent region becomes smaller, leading to an increase in the density of the current flowing in the luminescent element, thereby reducing the lifetime of the luminescent element.

In view of the above, the present invention has been conceived to solve the above conventional problem, and it is an object of the present invention to provide a luminescent display device with higher design flexibility by forming a capacitor without a region dedicated to the capacitor or a new region dedicated to the capacitor.

In order to achieve the above object, the luminescent display device according to an aspect of the present invention is a luminescent display device including: a substrate; a thin-film transistor which is formed above the substrate and includes: a semiconductor layer having a channel region, a source region, and a drain region; a gate insulating film formed on the semiconductor layer; a gate electrode formed on the gate insulating film; and a source electrode and a drain electrode which are electrically connected to the source region and the drain region of the semiconductor layer, respectively; an interlayer insulating film formed on the gate electrode; a luminescent element which is driven by a driving circuit to produce luminescence, the driving circuit including the thin-film transistor; and a first capacitor electrode formed on the interlayer insulating film in a region above the gate electrode, wherein the first capacitor electrode and the gate electrode constitute a first capacitor.

According to the present invention, it is possible to provide a luminescent display device with higher design flexibility by forming a capacitor without a region dedicated to the capacitor or a new region dedicated to the capacitor.

BRIEF DESCRIPTION OF THE DRAWINGS

These and other objects, advantages and features of the invention will become apparent from the following descrip-

tion thereof taken in conjunction with the accompanying drawings that illustrate a specific embodiment of the invention. In the Drawings:

FIG. 1 shows the layout of a pixel included in a conventional luminescent display device;

FIG. 2 is a block diagram showing an example structure of a luminescent display device according to Embodiment 1;

FIG. 3 shows a circuit structure of a luminescent pixel included in a display unit according to Embodiment 1;

FIG. 4 shows an example layout of a luminescent pixel according to Embodiment 1;

FIG. 5 shows a cross-sectional view of a luminescent pixel according to Embodiment 1;

FIG. 6 shows a circuit structure of a luminescent pixel according to a variation of Embodiment 1;

FIG. 7 shows a cross-sectional view of a luminescent pixel according to a variation of Embodiment 1;

FIG. 8 shows a circuit structure of a luminescent pixel according to another variation of Embodiment 1;

FIG. 9 shows a cross-sectional view of a luminescent pixel according to another variation of Embodiment 1;

FIG. 10 shows a circuit structure of a luminescent pixel included in a display unit according to Embodiment 2;

FIG. 11 shows an example layout of a luminescent pixel according to Embodiment 2;

FIG. 12 shows a cross-sectional view of a luminescent pixel according to Embodiment 2;

FIG. 13 is an external view of a television set which includes a luminescent display device according to the present invention; and

FIG. 14 shows an example layout of a luminescent pixel in another variation of a luminescent display device according to the present invention.

DESCRIPTION OF THE PREFERRED EMBODIMENT(S)

Hereinafter, embodiments of the luminescent display device according to the present invention are described with reference to the drawings.

The luminescent display device according to an aspect of the present invention is a luminescent display device including: a substrate; a thin-film transistor which is formed above the substrate and includes: a semiconductor layer having a channel region, a source region, and a drain region; a gate insulating film formed on the semiconductor layer; a gate electrode formed on the gate insulating film; and a source electrode and a drain electrode which are electrically connected to the source region and the drain region of the semiconductor layer, respectively; an interlayer insulating film formed on the gate electrode; a luminescent element which is driven by a driving circuit to produce luminescence, the driving circuit including the thin-film transistor; and a first capacitor electrode formed on the interlayer insulating film in a region above the gate electrode, wherein the first capacitor electrode and the gate electrode constitute a first capacitor.

With this, the gate electrode of the thin-film transistor is used not only simply as the gate electrode but also as one of two electrodes constituting the capacitor. Thus, the capacitor can be formed above the thin-film transistor to overlap with the thin-film transistor, enabling efficient use of the pixel space. As a result, a complex driving circuit which includes multiple thin-film transistors and multiple capacitors can be formed in a region having a limited area. It is to be noted that the structure of the present invention can be applied to a

capacitor for holding the gate voltage, as well as a capacitor for holding a threshold voltage V_{th} in the driving circuit.

Further, the luminescent display device may include a plurality of first capacitor electrodes including the first capacitor electrode, wherein each of the plurality of first capacitor electrodes and the gate electrode may constitute the first capacitor.

Furthermore, the first capacitor electrode and one of the source electrode and the drain electrode may form one layer, and the one of the source electrode and the drain electrode may be electrically connected to the first capacitor electrode.

With this, the other one of the two electrodes constituting the capacitor and one of the source electrode and the drain electrode can be formed in one process.

Moreover, the luminescent element may be electrically connected to one of the source electrode and the drain electrode, the thin-film transistor may be a driving transistor which supplies a driving current to the luminescent element, and the first capacitor may be a capacitor for setting a value of a current flowing in the driving transistor.

This makes it possible to form, in the driving circuit, the capacitor for setting the value of the driving current flowing in the driving transistor, while efficiently using the pixel space.

Further, the thin-film transistor may be a switching transistor which determines timing of supplying a driving current to the luminescent element, and the first capacitor may be a capacitor for initializing a capacitor used for setting a value of the driving current.

With this, one of the capacitor electrodes of the capacitor can be used also as, not only the gate electrode of the driving transistor, but also the gate electrode of the switching transistor. Therefore, it is possible to arrange a greater number of thin-film transistors and capacitors by efficiently using the limited pixel space.

Furthermore, the luminescent display device may further include a second capacitor, wherein the second capacitor may be electrically connected to the first capacitor in parallel.

With this, in addition to the first capacitor, the second capacitor is also formed in parallel, making it possible to increase the capacitance by the capacitance of the second capacitor.

Further, the second capacitor may include an upper second capacitor electrode and a lower second capacitor electrode, one of the upper second capacitor electrode and the lower second capacitor electrode may be electrically connected to the gate electrode, and the other one of the upper second capacitor electrode and the lower second capacitor electrode may be electrically connected to one of the source electrode and the drain electrode.

This makes it possible to increase the capacitance by the capacitance of the second capacitor, allowing for stability in the voltage even when there is a leak current, and thus crosstalk can be reduced.

Furthermore, the upper second capacitor electrode and one of the source electrode and the drain electrode may form one layer, the lower second capacitor electrode and the gate electrode may form one layer, and the first capacitor electrode may be electrically connected to the upper second capacitor electrode and to one of the source electrode and the drain electrode.

This makes it possible to form, as one layer, first ones of the capacitor electrodes constituting the first capacitor and the second capacitor, and to form, as another layer, second ones of the capacitor electrodes constituting the first capaci-

tor and the second capacitor, thereby enabling reduction in the number of manufacturing processes.

Moreover, an area of a lower surface of the first capacitor electrode, which is part of the first capacitor, in the region above the gate electrode may be 30% to 100% of an area of an upper surface of the gate electrode.

Further, the semiconductor layer may be made of polysilicon.

Furthermore, the luminescent element may be an organic electroluminescent element.

Furthermore, a capacitance of the first capacitor may be 0.1 to 10 pF.

Moreover, the luminescent display device may be a top-emission luminescent display device, and the luminescent element may be formed in a layer above the first capacitor electrode.

Moreover, the luminescent display device may be a bottom-emission luminescent display device, and the thin-film transistor and the first capacitor may be formed in a region other than a luminescent region in which the luminescent element is formed.

Embodiment 1

The luminescent display device according to Embodiment 1 includes a driving transistor and a capacitor, and the gate electrode of the driving transistor is one of two capacitor electrodes constituting the capacitor. Thus, the capacitor is formed in a region which is above the driving transistor and which includes the gate electrode of the driving transistor.

FIG. 2 is a block diagram showing an electrical structure of a luminescent display device 10 according to Embodiment 1. The luminescent display device 10 in FIG. 2 at least includes a control circuit 20, a scanning line driving circuit 40, a signal line driving circuit 50, and a display unit 60.

FIG. 3 shows a circuit structure of a luminescent pixel 100 included in the display unit 60 according to Embodiment 1. The luminescent pixel 100 in FIG. 3 includes a switching transistor 101, a capacitor 102, a driving transistor 103, an organic EL element 104, a signal line 105, a scanning line 106, a higher-voltage-side power line 107, and a lower-voltage-side power line 108.

First, the following describes the connection relationships and functions of the structural elements shown in FIG. 2.

The control circuit 20 has a function to control the scanning line driving circuit 40 and the signal line driving circuit 50. The control circuit 20 outputs a video signal received from outside, to the signal line driving circuit 50, and controls the operational timing of the scanning line driving circuit 40 according to the operation of the signal line driving circuit 50.

The scanning line driving circuit 40 is connected to the scanning line 106, and has a function to output a scan signal to the scanning line 106 to control between the conductive state (ON state) and the non-conductive state (OFF state) of the switching transistor 101 included in the luminescent pixel 100.

The signal line driving circuit 50 is connected to the signal line 105, and has a function to apply, to the luminescent pixel 100, a signal voltage based on a video signal.

The display unit 60 includes a plurality of luminescent pixels 100 which are two-dimensionally arranged, and displays an image based on the video signal input to the luminescent display device 10 from outside.

Next, the following describes the connection relationships and functions of the structural elements shown in FIG. 3.

The switching transistor 101 is an example of a switching element in which the gate is connected to the scanning line 106, one of the source and the drain is connected to the signal line 105, and the other one of the source and the drain is connected to a capacitor electrode 102a of the capacitor 102. The switching transistor 101 has a function to determine timing of applying the signal voltage at the signal line 105 to the capacitor electrode 102a of the capacitor 102. The switching transistor 101 is, for example, an n-type thin-film transistor (n-type TFT), but may be a p-type TFT.

The capacitor 102 is an example of the first capacitor and includes two capacitor electrodes 102a and 102b. The capacitor electrode 102a is connected to the gate of the driving transistor 103, whereas the capacitor electrode 102b is connected to the higher-voltage-side power line 107. The capacitor 102 holds a charge corresponding to the signal voltage supplied from the signal line 105. In other words, the capacitor 102 is an example of a capacitive element used for setting a value of a driving current supplied to the organic EL element 104. For example, the capacitor 102 has a function to cause the driving transistor 103 to supply the driving current to the organic EL element 104 even when the switching transistor 101 is switched to the OFF state, until another signal voltage is applied.

The driving transistor 103 is an example of a driving element in which the source is connected to the higher-voltage-side power line 107 and the drain is connected to the anode of the organic EL element 104. The driving transistor 103 converts a voltage corresponding to a signal voltage applied between the gate and the source into a source-drain current corresponding to the applied signal voltage. The driving transistor 103 then supplies the source-drain current to the organic EL element 104 as the driving current. The driving transistor 103 is a p-type thin-film transistor (p-type TFT), for example.

The organic EL element 104 is an example of a luminescent element which is driven to produce luminescence by a driving circuit which includes a thin-film transistor such as the driving transistor 103. In the organic EL element 104, the anode is connected to the drain of the driving transistor 103, and the cathode is connected to the lower-voltage-side power line 108. The organic EL element 104 produces luminescence when the driving transistor 103 passes the driving current through the organic EL element 104. The luminescence intensity is controlled by a magnitude of the driving current; in other words, the signal voltage.

The signal line 105 is connected to the signal line driving circuit 50 and to each of luminescent pixels in the pixel column that includes the luminescent pixel 100, and has a function to supply a signal voltage that determines the luminescence intensity. It is to be noted that the luminescent display device 10 includes the same number of signal lines 105 as the number of pixel columns.

The scanning line 106 is connected to the scanning line driving circuit 40 and to each of luminescent pixels in the pixel row that includes the luminescent pixel 100. With this, the scanning line 106 has a function to supply a signal indicating timing of applying the signal voltage to each of the luminescent pixels in the pixel row that includes the luminescent pixel 100. It is to be noted that the luminescent display device 10 includes the same number of scanning lines 106 as the number of pixel rows.

Although not shown in FIG. 2 or FIG. 3, each of the higher-voltage-side power line 107 and the lower-voltage-side power line 108 is also connected to other luminescent pixels and to a voltage source. The potential difference between a voltage source VDD to which the higher-voltage-

side power line **107** is connected and a voltage source VEE to which the lower-voltage-side power line **108** is connected has a magnitude which allows passage of a current which is sufficient to cause the organic EL element **104** to produce luminescence. It is to be noted that the lower-voltage-side power line **108** may be grounded.

As shown in the above structure, the luminescent display device **10** according to Embodiment 1 includes the display unit **60** in which a plurality of luminescent pixels **100** are two-dimensionally arranged. The display unit **60** displays video as the organic EL elements **104** in the luminescent pixels **100** produce luminescence at the luminescence intensity according to the signal voltages.

The following describes the positional relationships between the elements included in the luminescent pixel **100** according to Embodiment 1.

FIG. **4** shows an example layout of the luminescent pixel **100** according to Embodiment 1.

As shown in FIG. **4**, the luminescent pixel **100** can be separated into a driving circuit region **110** and a luminescent region **120**. In the luminescent region **120**, the organic EL element **104** is formed which produces luminescence according to the signal voltage supplied from the signal line **105**. It is to be noted that the luminescent display device **10** according to Embodiment 1 is assumed as a bottom-emission luminescent display device. To be more specific, luminescence produced by the organic EL element **104** is directed toward the bottom surface of the substrate. In other words, the display surface of the display unit **60** is on the bottom surface side of the substrate.

The driving circuit region **110** is the region of the luminescent pixel **100** excluding the luminescent region **120**, and is a region in which the driving circuit driving the organic EL element **104** is formed. In the driving circuit region **110**, the switching transistor **101**, the capacitor **102**, and the driving transistor **103** are formed.

FIG. **5** shows a cross-sectional view of the luminescent pixel **100** according to Embodiment 1. More specifically, FIG. **5** schematically shows a cross section A-A of the luminescent pixel **100** shown in FIG. **4**. The cross section A-A is a cross section showing the positional relationship between the capacitor **102** and the driving transistor **103**. For simplicity, FIG. **5** does not show the signal line **105** and the higher-voltage-side power line **107**.

As shown in FIG. **5**, the driving transistor **103** is formed on a substrate **210**. The driving transistor **103** includes a semiconductor layer **220**, a gate insulating film **230**, a gate electrode **103g**, a source electrode **103s**, and a drain electrode **103d**. Further, the capacitor **102** includes the capacitor electrode **102b**, an interlayer insulating film **240**, and the capacitor electrode **102a** which functions also as the gate electrode **103g**. Further, a planarizing film **250** is formed on the capacitor **102**.

The substrate **210** is, for example, a transparent substrate such as glass or quartz. The substrate **210** may be a flexible substrate such as a plastic. In the case of a top-emission luminescent display device, the substrate **210** may be a semiconductor substrate such as a silicon substrate, or a compound semiconductor substrate made with a compound semiconductor such as a nitride semiconductor.

Although it has been described above that the driving transistor **103** is formed on the substrate **210**, it may be formed above the substrate **210**. For example, a buffer layer may be formed on the substrate **210** and the driving transistor **103** may be formed on the buffer layer.

The semiconductor layer **220** is a semiconductor layer formed on the substrate **210** and includes a channel region

221, a source region **222**, and a drain region **223**. For example, the semiconductor layer **220** is made with a doped inorganic semiconductor such as polysilicon, microcrystalline silicon, or amorphous silicon, or an organic semiconductor.

It is to be noted that the driving transistor **103** is a p-type TFT, and thus, holes mainly contribute to the conduction in the channel region **221**. That is to say, the above-described driving current flows as the holes move from the source region **222** to the drain region **223** according to voltages applied to the source electrode **103s**, the drain electrode **103d**, and the gate electrode **103g**.

The gate insulating film **230** is, for example, a film having insulating properties, such as a silicon oxide film (SiO_x). In the example shown in FIG. **5**, the gate insulating film **230** is formed on the entire surface of the substrate **210** to cover the semiconductor layer **220**, and through-holes are formed in the regions above the source region **222** and the drain region **223**. The gate insulating film **230** is sufficient as long as it is formed on the channel region **221** at least.

The gate electrode **103g** is a metal electrode formed on the gate insulating film **230**. For example, the gate electrode **103g** has a single-layer structure of a metal such as molybdenum or tungsten, an alloy of molybdenum and tungsten, or polysilicon, or has a laminated structure of polysilicon, and titanium and tungsten, or the like. It is to be noted that the gate electrode **103g** is connected to the source or drain of the switching transistor **101** (not shown in FIG. **5**). The most significant feature of the present invention is that the gate electrode **103g** also functions as the capacitor electrode **102a** of the capacitor **102**.

The source electrode **103s** is formed on the source region **222**, and is made of a metal such as aluminum or copper or has a laminated structure of metals such as aluminum and molybdenum, for example. The source electrode **103s** is connected to the higher-voltage-side power line **107** (not shown in FIG. **5**). Further, as shown in FIG. **5**, the source electrode **103s** is connected to the capacitor electrode **102b** of the capacitor **102** via the through-hole formed in the interlayer insulating film **240** and in the gate insulating film **230**.

The drain electrode **103d** is formed on the drain region **223**, and is made of a metal such as aluminum or has a laminated structure of metals such as aluminum and molybdenum, for example. The drain electrode **103d** is connected to the anode of the organic EL element **104** (not shown in FIG. **5**).

The interlayer insulating film **240** is formed on the gate electrode **103g** and is made with, for example, a silicon nitride film (SiN_x), a silicon oxide film, or the like. In the example shown in FIG. **5**, the interlayer insulating film **240** is formed on the entire surface of the gate insulating film **230** to cover the gate electrode **103g**, and through-holes are formed in the regions above the source region **222** and the drain region **223**. The interlayer insulating film **240** is sufficient as long as it is formed on the gate electrode **103g** at least.

It is to be noted that the thickness of the interlayer insulating film **240** is 100 to 1000 nm.

The capacitor electrode **102b** is an example of the first capacitor electrode and is formed on the interlayer insulating film **240** above the gate electrode **103g**. Put it differently, the capacitor electrode **102b** is formed on the interlayer insulating film **240** in the region above the gate electrode **103g**. The capacitor electrode **102b**, together with the gate electrode **103g** that is the other capacitor electrode **102a**, constitutes the capacitor **102**. For example, the capacitor elec-

trode **102b** is made of a metal such as aluminum or copper, or has a laminated structure of metals such as aluminum and molybdenum. In this example, the capacitor electrode **102b** is connected to the higher-voltage-side power line **107**.

Further, the capacitor electrode **102b** and the source electrode **103s** form one layer and are connected to each other. More specifically, the capacitor electrode **102b** is connected to the source electrode **103s** via the through-hole formed in the interlayer insulating film **240**. Preferably, the capacitor electrode **102b** is made of the same material as that of the source electrode **103s**. This makes it possible to form the capacitor electrode **102b** and the source electrode **103s** in the same process, thereby achieving reduction in the number of processes.

The area of the lower surface of the capacitor electrode **102b** in the region above the gate electrode **103g**, which is the capacitor electrode **102a**, is 30% to 100% of the area of the upper surface of the gate electrode **103g**. It is to be noted that the capacitor electrode **102b** may be larger than the gate electrode **103g**. Further, the capacitance of the capacitor **102** is 0.1 to 10 pF.

The planarizing film **250** is formed on the capacitor **102**, and functions as a protection film which protects the capacitor **102** and the driving transistor **103** and also functions as a planarizing film which planarizes the upper surfaces of the capacitor **102** and the driving transistor **103**. The planarizing film **250** is made with, for example, a silicon oxide film (SiO_x), a silicon nitride film (SiN_x), or the like.

As shown in the above structure, the capacitor **102** uses the gate electrode **103g** as one of the capacitor electrodes. In other words, the capacitor **102** having the gate electrode **103g** as the capacitor electrode **102a** is formed in the region above the driving transistor **103**.

As shown in FIG. 4, this makes it possible to form the capacitor **102** without a region, in the luminescent pixel **100**, dedicated to the capacitor **102**. Therefore, it is possible to relatively flexibly design the area of the capacitor **102** or design the arrangement of the driving transistor **103** and the switching transistor **101**. Alternatively, another capacitor can be added to the driving circuit region **110**. As described above, with the luminescent display device **10** according to Embodiment 1, it is possible to increase the design flexibility. With this, for example, since the luminescent display device **10** according to Embodiment 1 is a bottom-emission luminescent display device, it is possible to ensure a wide area for the luminescent region **120**, reduce the density of the current flowing in the organic EL element **104**, and ensure a longer luminescence lifetime for the luminescent display device **10**.

It is to be noted that the structure in which the capacitor is formed above the driving transistor **103** as shown in the present embodiment can be applied to a driving circuit other than the circuit shown in FIG. 3. More specifically, the structure according to the present embodiment can be applied to a driving circuit having a circuit structure in which the gate of the driving transistor **103** is electrically connected to one of two capacitor electrodes constituting the capacitor. The following describes some variations with reference to the drawings.

(Variation 1)

FIG. 6 shows a circuit structure of a luminescent pixel **300** according to a variation of Embodiment 1. The luminescent pixel **300** shown in FIG. 6 includes switching transistors **101**, **313**, **314** and **315**, the driving transistor **103**, capacitors **311** and **312**, the organic EL element **104**, the signal line **105**, scanning lines **106**, **316**, **317** and **318**, the higher-voltage-side power line **107**, the lower-voltage-side power line **108**,

and a reference voltage power line **319**. It is to be noted that the same structural elements as that of the luminescent pixel **100** shown in FIG. 3 are given the same reference signs and the descriptions thereof are omitted below.

The switching transistor **313** is an example of a switching element in which the gate is connected to the scanning line **316**, one of the source and the drain is connected to the reference voltage power line **319**, and the other one of the source and the drain is connected to one of the source and the drain of the switching transistor **101**. The switching transistor **313** has a function to initialize the gate potential of the driving transistor **103**, that is, a function to set the gate potential of the driving transistor **103** to a reference potential V_{ref} .

To be more specific, the switching transistor **313** is turned on by a scanning signal supplied from the scanning line **316**, and supplies the reference potential V_{ref} to second electrodes of the capacitors. It is to be noted that the switching transistor **313** is an n-type TFT, for example.

The switching transistor **314** is an example of a switching element in which the gate is connected to the scanning line **317**, one of the source and the drain is connected to the gate of the driving transistor **103**, and the other one of the source and the drain is connected to the drain of the driving transistor **103**. The switching transistor **314** has a function to detect a threshold voltage of the driving transistor **103**.

More specifically, for example, the switching transistor **314** is turned on by a scanning signal supplied from the scanning line **317**, and short-circuits the gate and the drain of the driving transistor **103**. Accordingly, the threshold voltage of the driving transistor **103** is generated at the gate electrode of the driving transistor **103**. The switching transistor **314** is an n-type TFT, for example.

The switching transistor **315** is an example of a switching element in which the gate is connected to the scanning line **318**, one of the source and the drain is connected to the drain of the driving transistor **103**, and the other one of the source and the drain is connected to the anode of the organic EL element **104**. The switching transistor **315** has a function to determine timing of supplying the driving current to the organic EL element **104**.

More specifically, for example, the switching transistor **315** is turned on by a scanning signal supplied from the scanning line **318**, and when the driving transistor **103** is turned on while the switching transistor **315** is on, the driving current is supplied to the organic EL element **104**. To put it differently, the driving current is not supplied to the organic EL element **104** while the switching transistor **315** is off, regardless of the operation of the driving transistor **103**. It is to be noted that the switching transistor **315** is an n-type TFT, for example.

The capacitor **311** includes two capacitor electrodes **311a** and **311b**. The capacitor electrode **311a** is connected to the reference voltage power line **319**, whereas the capacitor electrode **311b** is connected to one of the source and the drain of the switching transistor **101**. The capacitor electrode **311b** is also connected to the gate of the driving transistor **103** via the capacitor **312**. The capacitor **311** holds a charge corresponding to the signal voltage supplied from the signal line **105**.

The capacitor **312** is an example of the first capacitor, and includes two capacitor electrodes **312a** and **312b**. The capacitor electrode **312b** is connected to one of the source and the drain of the switching transistor **101**, whereas the capacitor electrode **312a** is connected to the gate of the

11

driving transistor **103**. The capacitor **312** holds a charge corresponding to the threshold voltage of the driving transistor **103**.

The scanning lines **316**, **317** and **318** are connected to the scanning line driving circuit **40** and to each of luminescent pixels in the pixel column that includes the luminescent pixel **300**. The scanning line **316** has a function to supply a reference voltage for detecting the threshold voltage of the driving transistor **103** which is included in each of the luminescent pixels in the pixel row that includes the luminescent pixel **300**.

The scanning line **317** has a function to supply a signal indicating timing of detecting the threshold voltage of the driving transistor **103** which is included in each of the luminescent pixels in the pixel row that includes the luminescent pixel **300**. The scanning line **318** has a function to supply: a signal indicating timing of supplying the driving current to the organic EL element **104** which is included in each of the luminescent pixels in the pixel row that includes the luminescent pixel **300**; and a signal indicating timing of detecting the threshold voltage of the driving transistor **103**.

It is to be noted that the luminescent display device **10** includes the same number of scanning lines **316**, **317** and **318** as the number of pixel rows.

The reference voltage power line **319** is also connected to other luminescent pixels and to a voltage source which supplies a predetermined reference voltage. With this, the potential at the reference voltage power line **319** is maintained at the reference potential V_{ref} .

FIG. 7 shows a partial cross-sectional view of the luminescent pixel **300** according to Variation 1 of Embodiment 1. Specifically, FIG. 7 shows the structure in which the capacitor **312** and the driving transistor **103** are arranged. It is to be noted that the cross-sectional structure of the driving transistor **103** is the same as the cross-sectional structure shown in FIG. 5, and thus the description thereof is omitted below.

As shown in FIG. 7, the capacitor electrode **312b** of the capacitor **312** is formed on the interlayer insulating film **240**. The gate electrode **103g** functions also as the capacitor electrode **312a** of the capacitor **312**.

The capacitor electrode **312b** is an example of the first capacitor electrode, and is not connected to the source electrode **103s** or the drain electrode **103d** of the driving transistor **103**. The capacitor electrode **312b** is connected to one of the source and the drain of the switching transistor **101** and to the capacitor electrode **311b** (not shown in FIG. 7).

As described above, the capacitor electrode **312b** of the capacitor **311** formed on the driving transistor **103** does not have to be connected to each electrode of the driving transistor **103**. That is to say, the structure according to the present embodiment can be applied as long as one of the two electrodes constituting the capacitor is connected to the gate electrode **103g** of the driving transistor **103**.

(Variation 2)

FIG. 8 shows a circuit structure of a luminescent pixel **400** according to another variation of Embodiment 1. The luminescent pixel **400** shown in FIG. 8 is different from the luminescent pixel **300** shown in FIG. 6 in that the luminescent pixel **400** includes a capacitor **411** instead of the capacitor **311** and a switching transistor **413** instead of the switching transistor **313**. Hereinafter, the same structural elements as that of the luminescent pixel **300** shown in FIG. 6 are given the same reference signs and the descriptions thereof are omitted below.

12

The capacitor **411** is an example of the first capacitor, and includes two capacitor electrodes **411a** and **411b**. The capacitor electrode **411a** is connected to the gate electrode **103g** of the driving transistor **103**, whereas the capacitor electrode **411b** is connected to, for example, the higher-voltage-side power line **107**. The capacitor **411** holds a charge corresponding to the signal voltage supplied from the signal line **105** and to the threshold voltage of the driving transistor.

The switching transistor **413** is an example of a switching element in which the gate is connected to the scanning line **316**, one of the source and the drain is connected to the higher-voltage-side power line **107**, and the other one of the source and the drain is connected to one of the source and the drain of the switching transistor **101** and to the capacitor electrode **312b** of the capacitor **312**. The switching transistor **413** has a function to initialize the capacitor **312** and the capacitor **411**.

More specifically, the switching transistor **413** performs the initialization such that the capacitor **312** and the capacitor **411** hold the threshold voltage of the driving transistor **103** when the switching transistor **413** is turned on by a scanning signal supplied from the scanning line **316**, the potential at the capacitor electrode **312b** of the capacitor **312** is set to VDD, and the switching transistor **314** is turned on by a scanning signal supplied from the scanning line **317**. It is to be noted that the switching transistor **413** is an n-type TFT, for example.

FIG. 9 shows a cross-sectional view of the luminescent pixel **400** according to Variation 2 of Embodiment 1. Specifically, FIG. 9 shows the structure in which the capacitor **312**, the capacitor **411**, and the driving transistor **103** are arranged. It is to be noted that the cross-sectional structure of the driving transistor **103** is the same as the cross-sectional structure shown in FIG. 5, and thus the description thereof is omitted below.

As shown in FIG. 9, the capacitor electrode **312b** of the capacitor **312** and the capacitor electrode **411b** of the capacitor **411** are formed on the interlayer insulating film **240**. The gate electrode **103g** functions also as the capacitor electrode **312a** of the capacitor **312** and the capacitor electrode **411a** of the capacitor **411**.

The capacitor electrode **411b** is an example of the first capacitor electrode. The capacitor electrode **411b** and the source electrode **103s** of the driving transistor **103** form one layer and are connected to each other. More specifically, the capacitor electrode **411b** is connected to the source electrode **103s** via the through-hole formed in the interlayer insulating film **240**.

It is to be noted that the capacitor electrode **312b**, the capacitor electrode **411b**, and the source electrode **103s** are preferably made of the same material. This makes it possible to form the capacitor electrode **312b**, the capacitor electrode **411b**, and the source electrode **103s** in the same process, thereby achieving reduction in the number of processes.

As described above, the luminescent display device **10** according to Variation 2 of Embodiment 1 includes a plurality of first capacitor electrodes, and each of the plurality of first capacitor electrodes and the gate electrode **103g** constitute the first capacitor. Although the examples shown in FIG. 8 and FIG. 9 have illustrated two first capacitor electrodes, there may be three or more first capacitor electrodes formed on the interlayer insulating film **240** in the region above the gate electrode **103g**.

As described above, in the luminescent display device **10** according to Embodiment 1 and the variations thereof, the first capacitor is constituted by the gate electrode **103g** of the

driving transistor **103** included in the driving circuit and the first capacitor electrode formed above the gate electrode **103g**. The first capacitor having such a structure can be used as, for example, a capacitive element for setting a value of the driving current supplied to the organic EL element **104**.

This enables efficient use of the limited region within the luminescent pixel **100**. That is to say, the design flexibility can be increased. Accordingly, the luminescent display device **10** according to the present embodiment provides an advantageous effect of ensuring a wide region for the luminescent region **120**, for example.

It is to be noted that the luminescent display device **10** according to Embodiment 1 may further include a second capacitor which is electrically connected to the capacitor **102** in parallel. For example, the second capacitor includes an upper second capacitor electrode and a lower second capacitor electrode. One of the upper second capacitor electrode and the lower second capacitor electrode is connected to the gate electrode **103g**, and the other one is electrically connected to one of the source electrode **103s** and the drain electrode **103d**.

More specifically, the lower second capacitor electrode and the gate electrode **103g** may form one layer, and the upper second capacitor electrode and an electrically-connected one of the source electrode **103s** and the drain electrode **103d** may form one layer. Here, the capacitor electrode **102a** of the capacitor **102** is electrically connected to the upper second capacitor electrode.

Embodiment 2

The luminescent display device according to Embodiment 2 includes a switching transistor, a driving transistor, and a capacitor, and the gate electrode of the switching transistor is one of two capacitor electrodes constituting the capacitor. Thus, the capacitor is formed in the region above the switching transistor.

The luminescent display device according to Embodiment 2 is different from the luminescent display device **10** according to Embodiment 1 in circuit structure of each luminescent pixel included in the display unit and in arrangement of elements constituting each luminescent pixel. In other words, the luminescent display device according to Embodiment 2 has the same electrical structure as that of the luminescent display device **10** according to Embodiment 1 shown in FIG. 2. Thus, the description of the electrical structure of the luminescent display device according to Embodiment 2 is omitted, and the following description centers on the circuit structure of each luminescent pixel and on the arrangement of the elements constituting each luminescent pixel.

FIG. 10 shows a circuit structure of a luminescent pixel **500** included in a display unit according to Embodiment 2. The luminescent pixel **500** in FIG. 10 includes switching transistors **501**, **506**, **507** and **508**, capacitors **502** and **505**, a driving transistor **503**, an organic EL element **504**, a signal line **509**, scanning lines **510**, **511**, **512** and **513**, a higher-voltage-side power line **514**, a lower-voltage-side power line **515**, and a reference voltage power line **516**.

The switching transistor **501** is an example of a switching element in which the gate is connected to the scanning line **510**, one of the source and the drain is connected to the signal line **509**, and the other one of the source and the drain is connected to a capacitor electrode **502a** of the capacitor **502** and to the gate of the driving transistor **503**. The switching transistor **501** has a function to determine timing of applying a signal voltage at the signal line **509** to the

capacitor electrode **502a** of the capacitor **502**. The switching transistor **501** is an n-type TFT, for example.

The capacitor **502** is an example of the first capacitor corresponding to the driving transistor **503**, and includes two capacitor electrodes **502a** and **502b**. The capacitor electrode **502a** is connected to the gate of the driving transistor **503**, whereas the capacitor electrode **502b** is connected to a capacitor electrode **505b** of the capacitor **505** and to the source or drain of the switching transistor **507**. The capacitor **502** holds a charge corresponding to the signal voltage supplied from the signal line **509** and to a threshold voltage of the driving transistor **503**. In other words, the capacitor **502** is an example of a capacitive element for setting a value of a driving current supplied to the organic EL element **504**.

The driving transistor **503** is an example of a driving element in which the drain is connected to the higher-voltage-side power line **514**, and the source is connected to the anode of the organic EL element **504** via the switching transistor **508**. The driving transistor **503** converts a voltage corresponding to a signal voltage applied between the gate and the source into a source-drain current corresponding to that signal voltage. The driving transistor **503** is an n-type TFT, for example.

The organic EL element **504** is an example of a luminescent element in which the anode is connected to the source of the driving transistor **503** via the switching transistor **508**, and the cathode is connected to the lower-voltage-side power line **515**. The organic EL element **504** produces luminescence when the driving transistor **503** passes the driving circuit through the organic EL element **504**.

The capacitor **505** is an example of the first capacitor corresponding to the switching transistor **508**, and includes two capacitor electrodes **505a** and **505b**. The capacitor electrode **505a** is connected to the scanning line **513**, whereas the capacitor electrode **505b** is connected to the capacitor electrode **502b** and to one of the source and the drain of the switching transistor **507**. The capacitor **505** is an example of a capacitive element for adjusting the amount of voltage held by the capacitor **502** which is a capacitive element which holds a data voltage applied from the signal line **509**.

The switching transistor **506** is an example of a switching element in which the gate is connected to the scanning line **511**, one of the source and the drain is connected to the reference voltage power line **516**, and the other one of the source and the drain is connected to the gate of the driving transistor **503**. The switching transistor **506** has a function to apply a reference voltage V_{ref} to the gate of the driving transistor **503**. It is to be noted that the switching transistor **506** is an n-type TFT, for example.

The switching transistor **507** is an example of a switching element in which the gate is connected to the scanning line **512**, one of the source and the drain is connected to the capacitor electrode **502b** of the capacitor **502**, and the other one of the source and the drain is connected to the source of the driving transistor **503**. The switching transistor **507** has a function to disconnect the capacitor **502** and the source of the driving transistor **503** when applying a signal voltage to the capacitor **502**. It is to be noted that the switching transistor **507** is an n-type TFT, for example.

The switching transistor **508** is an example of a switching element in which the gate is connected to the scanning line **513**, one of the source and the drain is connected to the source of the driving transistor **503**, and the other one of the source and the drain is connected to the anode of the organic EL element **504**. The switching transistor **508** has a function to determine timing of supplying the driving current to the

organic EL element **504**. It is to be noted that the switching transistor **508** is an n-type TFT, for example.

The signal line **509** is connected to the signal line driving circuit and to each of luminescent pixels in the pixel column that includes the luminescent pixel **500**, and has a function to supply a signal voltage that determines the luminescence intensity. It is to be noted that the luminescent display device according to Embodiment 2 includes the same number of signal lines **509** as the number of pixel columns.

The scanning lines **510**, **511**, **512** and **513** are connected to the scanning line driving circuit and to each of luminescent pixels in the pixel row that includes the luminescent pixel **500**. The scanning line **510** has a function to supply a signal indicating timing of applying the signal voltage to each of the luminescent pixels in the pixel row that includes the luminescent pixel **500**.

The scanning line **511** has a function to supply a signal indicating timing of applying a reference voltage V_{ref} to the gate of the driving transistor **503** in each of the luminescent pixels in the pixel row that includes the luminescent pixel **500**. The scanning line **512** has a function to supply a signal indicating timing of disconnecting the capacitor **502** and the source of the driving transistor **503** in each of the luminescent pixels in the pixel row that includes the luminescent pixel **500**. The scanning line **513** has a function to supply a signal indicating timing of supplying the driving current to the organic EL element **504** in each of the luminescent pixels in the pixel row that includes the luminescent pixel **500**.

It is to be noted that the luminescent display device according to Embodiment 2 includes the same number of scanning lines **510**, **511**, **512** and **513** as the number of pixel rows.

Although not shown in FIG. 10, the higher-voltage-side power line **514**, the lower-voltage-side power line **515**, and the reference voltage power line **516** are each connected to other luminescent pixels and to a voltage source. The potential difference between the voltage source to which the higher-voltage-side power line **514** is connected and the voltage source to which the lower-voltage-side power line **515** is connected has a magnitude which allows a flow of a current sufficient for the organic EL element **504** to produce luminescence. It is to be noted that the lower-voltage-side power line **515** may be grounded.

FIG. 11 shows an example layout of the luminescent pixel **500** according to Embodiment 2. The luminescent display device according to Embodiment 2 is assumed as a top-emission luminescent display device. To be more specific, the luminescence produced by the organic EL element **504** is directed toward the top surface of the substrate. In other words, the display surface of the display unit is on the top surface side of the substrate.

In the luminescent pixel **500**, the luminescent region in which the organic EL element **504** is formed is the same as the driving circuit region. That is to say, the luminescent region is formed above the driving circuit region.

As shown in FIG. 11, the driving transistor **503** and the capacitor **502** are formed in the same region in the plane to overlap each other, and the switching transistor **508** and the capacitor **505** are formed in the same region in the plane to overlap each other. The structure according to the present embodiment can be applied to such a circuit structure as above in which the gate of a thin-film transistor such as the driving transistor **503** or the switching transistor **508** is electrically connected with a capacitor electrode of a capacitor.

FIG. 12 shows a cross-sectional view of the luminescent pixel **500** according to Embodiment 2. More specifically,

FIG. 12 shows a structure in which the switching transistor **508**, the capacitor **505**, and the organic EL element **504** are arranged.

It is to be noted that the structure of the switching transistor **508** is the same as that of the driving transistor **103** shown in FIG. 7. To be more specific, a substrate **610**, a semiconductor layer **620**, a gate insulating film **630**, an interlayer insulating film **640**, a gate electrode **508g**, a source electrode **508s**, and a drain electrode **508d** which are shown in FIG. 12 correspond to the substrate **210**, the semiconductor layer **220**, the gate insulating film **230**, the interlayer insulating film **240**, the gate electrode **103g**, the source electrode **103s**, and the drain electrode **103d** which are shown in FIG. 7, respectively. Further, a channel region **621**, a source region **622**, and a drain region **623** included in the semiconductor layer **620** correspond to the channel region **221**, the source region **222**, and the drain region **223** included in the semiconductor layer **220**, respectively.

As shown in FIG. 12, the capacitor electrode **505b** of the capacitor **505** is an example of the first capacitor electrode, and the capacitor electrode **505b** and the source electrode **508s** form one layer and are connected to each other. It is to be noted that instead of being connected to the source electrode **508s**, the capacitor electrode **505b** may be electrically connected to the drain electrode **508d**.

Since the luminescent display device according to Embodiment 2 is a top-emission luminescent display device, the organic EL element **504** is formed in a layer above the capacitor **505**. More specifically, as shown in FIG. 12, the organic EL element **504** is formed above the capacitor **505** with a planarizing film **650** therebetween. The organic EL element **504** includes an anode **504a**, a luminescent layer **504b**, and a transparent cathode **504c**.

The planarizing film **650** is made with a silicon nitride film, for example.

The anode **504a** is a light-reflective electrode and is made of a metal such as aluminum, for example. The anode **504a** has a function to reflect luminescence produced by the luminescent layer **504b**. The anode **504a** is the anode electrode of the organic EL element **504**, and is connected to the source of the driving transistor **503** via the switching transistor **508** as shown in FIG. 10.

The luminescent layer **504b** is a luminescent layer which is formed between the anode **504a** and the transparent cathode **504c** which is transparent or semitransparent, and produces luminescence due to recombination of the holes and electrons injected from the anode **504a** and the transparent cathode **504c**, respectively. It is to be noted that the luminescent layer **504b** may include a hole transport layer, a hole injection layer, an electron transport layer, an electron injection layer, and so on.

The transparent cathode **504c** is a light-transmissive electrode and is made with a transparent conductive oxide film such as an indium tin oxide (ITO), for example. The transparent cathode **504c** is the cathode electrode of the organic EL element **504**, and is connected to the lower-voltage-side power line **515** as shown in FIG. 10.

As described above, with the luminescent display device according to Embodiment 2, the capacitor **505** is constituted by the gate electrode **508g** of the switching transistor **508** included in the driving circuit and the capacitor electrode **505b** formed above the gate electrode **508g**. The capacitor **505** having such a structure can be used as, for example, a capacitive element for: initializing a capacitive element for setting the value of the driving current supplied to the organic EL element **504**; and adjusting the amount of

voltage to be held by the capacitive element out of the data voltage applied from the signal line 509.

Thus, the structure of the present embodiment can be applied to a driving circuit having a circuit structure in which the gate electrode of a switching transistor and one of the capacitor electrodes of a capacitor are electrically connected. As a result, it is possible to reduce the region dedicated to the capacitor, and thus the design flexibility of the driving circuit can be increased.

Although the luminescent display device according to the present invention has been described above based on some exemplary embodiments, the present invention is not intended to be limited to such embodiments. Those skilled in the art may arrive at many modifications to the above exemplary embodiments and at various embodiments implemented by combining the structural elements of different embodiments without materially departing from the novel teachings and advantages of the present invention. Accordingly, all such modifications and embodiments are intended to be included within the scope of the present invention.

For example, the present invention is applicable to a circuit having a circuit structure in which the gate of a thin-film transistor included in a driving circuit is connected with one of the electrodes of a capacitor. Although the above embodiments have described the structure in which the gate of a driving transistor or a switching transistor is connected with one of the electrodes of a capacitor, the circuit structure and so on is not limited to the above description.

Further, the above embodiments have described the switching transistors as the n-type transistors which are turned on when a positive voltage is applied to the gate of the switching transistors. However, the same advantageous effect as that of the above-described embodiments can be provided also by a video display device in which the switching transistors are p-type transistors and the polarity of the scanning lines is reversed. Furthermore, although the above description explained that the lower electrode is the anode and the upper electrode is the cathode, it may surely be that the lower electrode is the cathode and the upper electrode is the anode.

Moreover, for example, the luminescent display device according to the present invention is built in a television set as shown in FIG. 13. With the built-in luminescent display device according to the present invention, it is possible to provide a television set capable of high-precision image display that reflects video signals.

Furthermore, the luminescent display device according to the present invention may include a second capacitor which is electrically connected in parallel with a first capacitor having the gate electrode of a thin-film transistor as the lower electrode as described above.

FIG. 14 shows an example layout of a luminescent pixel in another variation of the luminescent display device according to the present invention. In FIG. 14, the same structural elements as that of the conventional luminescent display device shown in FIG. 1 are given the same reference signs and the descriptions thereof are omitted below.

As shown in FIG. 14, the luminescent pixel 700 includes a first capacitor 708 and a capacitor 702 which is a second capacitor. The first capacitor 708 is formed on the driving transistor 703 and includes an upper electrode and a lower electrode. The lower electrode of the first capacitor 708 functions also as the gate electrode of the driving transistor 703. The capacitor 702 which is the second capacitor includes an upper second capacitor electrode and a lower second capacitor electrode.

The upper electrode of the first capacitor 708 is electrically connected to the upper second capacitor electrode of the capacitor 702. More specifically, as shown in FIG. 14, the upper electrode of the first capacitor 708, the upper second capacitor electrode of the capacitor 702, the power line 707, and one of the source electrode and the drain electrode of the driving transistor 703 form one layer, and the upper electrode of the first capacitor 708 is electrically connected to the one of the source electrode and the drain electrode of the driving transistor 703.

The lower electrode of the first capacitor 708 functions as the gate electrode of the driving transistor 703 as described above, and is electrically connected to the lower second capacitor electrode of the capacitor 702. More specifically, as shown in FIG. 14, the lower second capacitor electrode of the capacitor 702 and the gate electrode which is the lower electrode of the first capacitor 708 form one layer and are electrically connected.

The above structure makes it possible to efficiently use the region above the driving transistor 703 and to increase the capacity of the capacitor 702.

INDUSTRIAL APPLICABILITY

The luminescent display device according to the present invention is applicable to various display devices such as television sets, personal computers, and mobile phones.

What is claimed is:

1. A luminescent display device, comprising:
 - a substrate; and
 - a plurality of pixels above the substrate, each of the pixels including:
 - a thin film transistor above the substrate, the thin film transistor including:
 - a semiconductor layer comprising a channel region, a source region, and a drain region;
 - a source electrode electrically connected to the source region of the semiconductor layer; and
 - a drain electrode electrically connected to the drain region of the semiconductor layer;
 - a lower electrode above the substrate, the lower electrode including a first portion and a second portion, the first portion of the lower electrode being provided in a region in which the thin film transistor is provided, the first portion of the lower electrode comprising a gate electrode of the thin film transistor, the second portion of the lower electrode being provided in a region other than the region in which the thin-film transistor is provided the lower electrode, including the first portion and the second portion, comprising one continuous layer;
 - an interlayer insulating film on the lower electrode;
 - an upper electrode on the interlayer insulating film, the upper electrode including a first portion and a second portion, the upper electrode, including the first portion and the second portion, comprising one continuous layer, the first portion of the upper electrode comprising a capacitor electrode directly above the gate electrode, the first portion of the upper electrode further comprising the source electrode, the capacitor electrode and the source electrode being connected via a through-hole in the interlayer insulating film; and
 - a luminescent element configured to be driven by a driver to produce luminescence, the driver including the thin film transistor,

wherein the first portion of the upper electrode and the first portion of the lower electrode comprise a first capacitance, and the second portion of the upper electrode and the second portion of the lower electrode comprise a second capacitance.] 5

[2. The luminescent display device according to claim 1, wherein an area of a lower surface of the first portion of the upper electrode, in the region in which the thin film transistor is provided, is approximately 30% to approximately 100% of an area of an upper surface of the gate electrode.] 10

[3. The luminescent display device according to claim 1, wherein the semiconductor layer comprises polysilicon.]

[4. The luminescent display device according to claim 1, wherein the first capacitance is approximately 0.1 pF to approximately 10 pF.] 15

[5. The luminescent display device according to claim 1, wherein the luminescent display device is a top-emission luminescent display device, and the luminescent element is in a layer above the upper electrode.] 20

[6. The luminescent display device according to claim 1, wherein the luminescent display device is a bottom-emission luminescent display device, and the thin-film transistor, the lower electrode, and the upper electrode are in a region other than a luminescent region in which the luminescent element is disposed.] 25

[7. The luminescent display device according to claim 1, wherein the one continuous layer of the upper electrode includes the source electrode of the thin film transistor.] 30

[8. The luminescent display device according to claim 7, further comprising:

a power line connected to the one of the source electrode and the drain electrode of the thin film transistor, wherein the one continuous layer of the upper electrode further includes the power line.] 35

9. A luminescent display device, comprising:

a substrate; and

a plurality of pixels above the substrate,

each of the pixels including:

a thin film transistor above the substrate, the thin film transistor including:

a semiconductor layer including a channel region, a source region, and a drain region;

a source electrode configured to be electrically connected to the source region of the semiconductor layer; and 45

a drain electrode configured to be electrically connected to the drain region of the semiconductor layer; 50

a lower electrode above the substrate, the lower electrode including a first portion and a second portion, the first portion of the lower electrode being provided in a region above the channel region, the first portion of the lower electrode comprising a gate electrode of the thin film transistor, the second portion of the lower electrode being provided in a region other than the region above the channel region, the lower electrode, including the first portion and the second portion, comprising one continuous layer; 55

an interlayer insulating film above the lower electrode; an upper electrode, contacting the interlayer insulating film, which is configured to be electrically connected to one of the source region and the drain region of the semiconductor layer via a through-hole in the interlayer insulating film, the upper electrode including a first portion and a second portion, the upper 65

electrode, including the first portion and the second portion, comprising one continuous layer, the first portion of the upper electrode overlapping the first portion of the lower electrode to form a first capacitance, the second portion of the upper electrode overlapping the second portion of the lower electrode to form a second capacitance; and

a luminescent element configured to be driven by a driver to produce luminescence, the driver including the thin film transistor,

wherein the first portion of the upper electrode extends from the second portion of the upper electrode to overlap the first portion of the lower electrode to form the first capacitance, with the upper electrode including a physical separation that is above the semiconductor layer and that is between the first portion of the upper electrode and a region of the through-hole above the semiconductor layer.

10. The luminescent display device according to claim 9, wherein an area of a lower surface of the first portion of the upper electrode, in the region above the channel region, is approximately 30% to approximately 100% of an area of an upper surface of the gate electrode.

11. The luminescent display device according to claim 9, wherein the semiconductor layer comprises polysilicon.

12. The luminescent display device according to claim 9, wherein the first capacitance is approximately 0.1 pF to approximately 10 pF.

13. The luminescent display device according to claim 9, wherein the luminescent display device is a top-emission luminescent display device, and the luminescent element is in a layer above the upper electrode.

14. The luminescent display device according to claim 9, wherein the first portion of the upper electrode is configured to be electrically connected to one of the source region and the drain region via one of the source electrode and the drain electrode.

15. The luminescent display device according to claim 9, wherein the first portion of the upper electrode, the second portion of the upper electrode, and one of the source electrode and the drain electrode comprise one continuous layer.

16. A luminescent display device, comprising:

a substrate; and

a plurality of pixels above the substrate,

each of the pixels including:

a thin film transistor above the substrate, the thin film transistor including:

a semiconductor layer including a channel region, a source region, and a drain region;

a source electrode electrically connected to the source region of the semiconductor layer; and

a drain electrode electrically connected to the drain region of the semiconductor layer;

a lower electrode above the substrate, the lower electrode including a first portion and a second portion, the first portion of the lower electrode being provided in a region above the channel region, the first portion of the lower electrode comprising a gate electrode of the thin film transistor, the second portion of the lower electrode being provided in a region other than the region above the channel region, the lower electrode, including the first portion and the second portion, comprising one continuous layer; an interlayer insulating film above the lower electrode; an upper electrode, contacting the interlayer insulating film, which is configured to be electrically connected

to one of the source region and the drain region of the semiconductor layer via a through-hole in the interlayer insulating film, the upper electrode including a first portion and a second portion, the upper electrode, including the first portion and the second 5 portion, comprising one continuous layer, the first portion of the upper electrode overlapping the first portion of the lower electrode to form a first capacitance, the second portion of the upper electrode overlapping the second portion of the lower electrode to form a second capacitance; and 10

a luminescent element configured to be driven by a driver to produce luminescence, the driver including the thin film transistor, 15

wherein the first portion of the upper electrode extends from the second portion of the upper electrode to overlap the first portion of the lower electrode to form the first capacitance, with the upper electrode not being above a first portion of the interlayer insulating film that is between a second portion of the interlayer 20 insulating film and the through-hole in the interlayer insulating film, the second portion of the interlayer insulating film being between the gate electrode and a part of the first portion of the upper electrode which is directly above the gate electrode. 25

17. The luminescent display device according to claim 16, wherein an area of a lower surface of the first portion of the upper electrode, in the region above the channel region, is approximately 30% to approximately 100% of an area of an upper surface of the gate electrode. 30

18. The luminescent display device according to claim 16, wherein the semiconductor layer comprises polysilicon.

19. The luminescent display device according to claim 16, wherein the first capacitance is approximately 0.1 pF to approximately 10 pF. 35

20. The luminescent display device according to claim 16, wherein the luminescent display device is a top-emission luminescent display device, and the luminescent element is in a layer above the upper electrode.

21. The luminescent display device according to claim 16, wherein the first portion of the upper electrode is configured to be electrically connected to one of the source region and the drain region via one of the source electrode and the drain electrode. 40

22. The luminescent display device according to claim 16, wherein the first portion of the upper electrode, the second portion of the upper electrode, and one of the source electrode and the drain electrode comprise one continuous layer. 45

23. A luminescent display device, comprising:

- a substrate; and
- a plurality of pixels above the substrate, each of the pixels including:
 - a thin film transistor above the substrate, the thin film transistor including:
 - a semiconductor layer including a channel region, a source region, and a drain region;
 - a source electrode electrically connected to the source region of the semiconductor layer; and
 - a drain electrode electrically connected to the drain 60 region of the semiconductor layer;
 - a lower electrode above the substrate, the lower electrode including a first portion and a second portion, the first portion of the lower electrode being provided in a region above the channel region, the first 65 portion of the lower electrode comprising a gate electrode of the thin film transistor, the second por-

tion of the lower electrode being provided in a region other than the region above the channel region, the lower electrode, including the first portion and the second portion, comprising one continuous layer; 5

an interlayer insulating film above the lower electrode; an upper electrode contacting the interlayer insulating film, the upper electrode including a first portion and a second portion, the upper electrode, including the first portion and the second portion, comprising one continuous layer, the first portion of the upper electrode being above the gate electrode, a part of the upper electrode being connected to one of the source electrode and the drain electrode, the part of the upper electrode and the one of the source electrode and the drain electrode being connected via a through-hole in the interlayer insulating film; and 10

a luminescent element configured to be driven by a driver to produce luminescence, the driver including the thin film transistor, 15

wherein the first portion of the upper electrode and the first portion of the lower electrode form a first capacitance in a region corresponding to the channel region, 20

the second portion of the upper electrode and the second portion of the lower electrode form a second capacitance in a region other than the region corresponding to the channel region, and 25

the first portion of the upper electrode extends from the second portion of the upper electrode to be above the gate electrode, with the upper electrode including a physical separation that is above the semiconductor layer and that is between the first portion of the upper electrode and a region of the through-hole above the semiconductor layer. 30

24. The luminescent display device according to claim 23, wherein an area of a lower surface of the first portion of the upper electrode, in the region above the channel region, is approximately 30% to approximately 100% of an area of an upper surface of the gate electrode. 35

25. The luminescent display device according to claim 23, wherein the semiconductor layer comprises polysilicon.

26. The luminescent display device according to claim 23, wherein the first capacitance is approximately 0.1 pF to approximately 10 pF. 40

27. The luminescent display device according to claim 23, wherein the luminescent display device is a top-emission luminescent display device, and the luminescent element is in a layer above the upper electrode.

28. The luminescent display device according to claim 23, wherein the first portion of the upper electrode is configured to be electrically connected to one of the source region and the drain region via one of the source electrode and the drain electrode. 45

29. The luminescent display device according to claim 23, wherein the first portion of the upper electrode, the second portion of the upper electrode, and one of the source electrode and the drain electrode comprise one continuous layer. 50

30. A luminescent display device, comprising:

- a substrate; and
- a plurality of pixels above the substrate, each of the pixels including:
 - a thin film transistor above the substrate, the thin film transistor including:
 - a semiconductor layer including a channel region, a source region, and a drain region;

23

a source electrode electrically connected to the source region of the semiconductor layer; and a drain electrode electrically connected to the drain region of the semiconductor layer;

a lower electrode above the substrate, the lower electrode including a first portion and a second portion, the first portion of the lower electrode being provided in a region above the channel region, the first portion of the lower electrode comprising a gate electrode of the thin film transistor, the second portion of the lower electrode being provided in a region other than the region above the channel region, the lower electrode, including the first portion and the second portion, comprising one continuous layer;

an interlayer insulating film above the lower electrode; an upper electrode contacting the interlayer insulating film, the upper electrode including a first portion and a second portion, the upper electrode, including the first portion and the second portion, comprising one continuous layer, the first portion of the upper electrode being above the gate electrode, a part of the upper electrode being connected to one of the source electrode and the drain electrode, the part of the upper electrode and the one of the source electrode and the drain electrode being connected via a through-hole in the interlayer insulating film; and

a luminescent element configured to be driven by a driver to produce luminescence, the driver including the thin film transistor,

wherein the first portion of the upper electrode and the first portion of the lower electrode form a first capacitance in a region corresponding to the channel region,

the second portion of the upper electrode and the second portion of the lower electrode form a second capacitance in a region other than the region corresponding to the channel region, and

24

the first portion of the upper electrode extends from the second portion of the upper electrode to be above the gate electrode, with the upper electrode not being above a first portion of the interlayer insulating film that is between a second portion of the interlayer insulating film and the through-hole in the interlayer insulating film, the second portion of the interlayer insulating film being between the gate electrode and a part of the first portion of the upper electrode which is directly above the gate electrode.

31. The luminescent display device according to claim 30, wherein an area of a lower surface of the first portion of the upper electrode, in the region above the channel region, is approximately 30% to approximately 100% of an area of an upper surface of the gate electrode.

32. The luminescent display device according to claim 30, wherein the semiconductor layer comprises polysilicon.

33. The luminescent display device according to claim 30, wherein the first capacitance is approximately 0.1 pF to approximately 10 pF.

34. The luminescent display device according to claim 30, wherein the luminescent display device is a top-emission luminescent display device, and the luminescent element is in a layer above the upper electrode.

35. The luminescent display device according to claim 30, wherein the first portion of the upper electrode is configured to be electrically connected to one of the source region and the drain region via one of the source electrode and the drain electrode.

36. The luminescent display device according to claim 30, wherein the first portion of the upper electrode, the second portion of the upper electrode, and one of the source electrode and the drain electrode comprise one continuous layer.

* * * * *