



US00RE49920E

(19) **United States**
(12) **Reissued Patent**
Kishigami

(10) **Patent Number: US RE49,920 E**
(45) **Date of Reissued Patent: Apr. 16, 2024**

(54) **RADAR APPARATUS AND RADAR METHOD**

(56) **References Cited**

(71) Applicant: **Panasonic Corporation**, Osaka (JP)

U.S. PATENT DOCUMENTS

(72) Inventor: **Takaaki Kishigami**, Tokyo (JP)

4,539,565 A * 9/1985 Norsworthy G01S 7/4008
342/128

(73) Assignee: **PANASONIC HOLDINGS CORPORATION**, Osaka (JP)

4,652,883 A * 3/1987 Andricos H01Q 3/385
333/139

(Continued)

(21) Appl. No.: **17/706,418**

FOREIGN PATENT DOCUMENTS

(22) Filed: **Mar. 28, 2022**

JP 2-243022 A 9/1990
JP 2000-338226 A 12/2000

(Continued)

Related U.S. Patent Documents

Reissue of:

(64) Patent No.: **10,641,882**
Issued: **May 5, 2020**
Appl. No.: **15/908,986**
Filed: **Mar. 1, 2018**

OTHER PUBLICATIONS

Japanese Office Action, dated Aug. 22, 2023, for Japanese Patent Application No. 2022-123226. (6 pages) (with English translation).
(Continued)

(30) **Foreign Application Priority Data**

Mar. 7, 2017 (JP) 2017-043079

Primary Examiner — Mark Sager

(74) *Attorney, Agent, or Firm* — Seed IP Law Group LLP

(51) **Int. Cl.**
G01S 13/04 (2006.01)
G01S 7/02 (2006.01)

(Continued)

(57) **ABSTRACT**

A radar apparatus includes a radar transmitter that transmits a radar signal in a predetermined transmission cycle and a radar receiver that receives a reflection wave signal being a reflection of the radar signal on a target. The radar transmitter includes a phase rotation controller that randomly varies a pattern of a phase rotation every period corresponding to a plurality of transmission cycles, the pattern being to be applied to the radar signal within a period, and a transmission phase rotator that assigns a first phase rotation to the radar signal in accordance with the pattern. The radar receiver includes a reception phase rotator that assigns a second phase rotation in a direction opposite to a direction of the first phase rotation to the reflection wave signal in accordance with the pattern.

(52) **U.S. Cl.**
CPC **G01S 7/0234** (2021.05); **G01S 7/023** (2013.01); **G01S 7/288** (2013.01); **G01S 7/2921** (2013.01);

(Continued)

(58) **Field of Classification Search**
CPC G01S 7/0234; G01S 7/023; G01S 7/288; G01S 7/2921; G01S 13/04; G01S 13/106; G01S 13/288; G01S 13/86

See application file for complete search history.

10 Claims, 8 Drawing Sheets

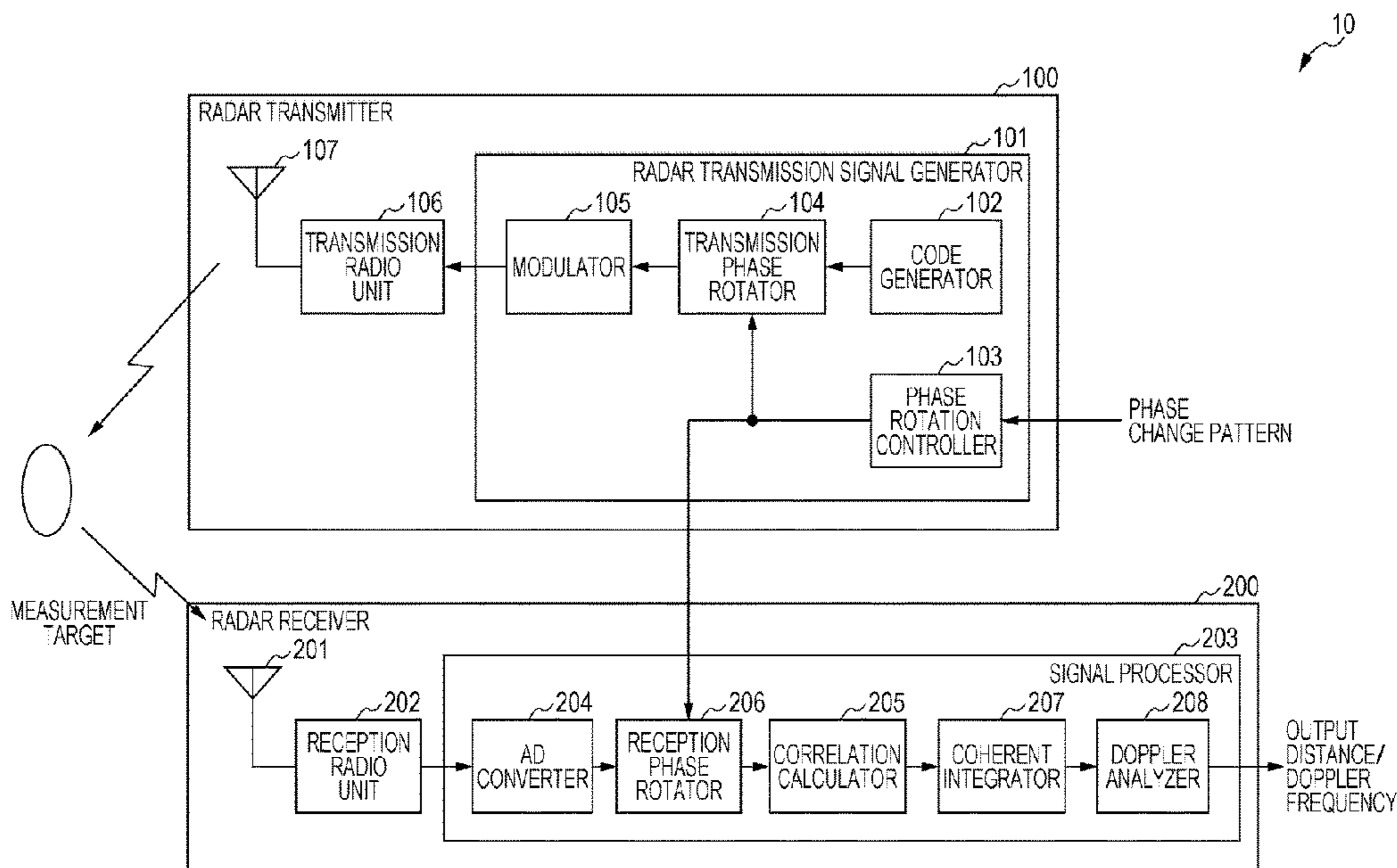

US RE49,920 E

- (51) **Int. Cl.**
G01S 7/288 (2006.01)
G01S 7/292 (2006.01)
G01S 13/10 (2006.01)
G01S 13/28 (2006.01)
G01S 13/86 (2006.01)
- (52) **U.S. Cl.**
 CPC *G01S 13/04* (2013.01); *G01S 13/106*
 (2013.01); *G01S 13/288* (2013.01); *G01S*
13/86 (2013.01)

- 2014/0348217 A1* 11/2014 Hsieh H03K 19/017509
 375/219
 2015/0061915 A1* 3/2015 Kishigami G01S 7/023
 342/27
 2015/0123840 A1* 5/2015 Morita G01S 7/02
 342/175
 2015/0198710 A1* 7/2015 Tokuhiko G01S 13/36
 342/104
 2015/0369912 A1* 12/2015 Kishigami G01S 13/26
 342/113
 2016/0211953 A1* 7/2016 Ezaki H04L 27/0014
 2016/0212616 A1* 7/2016 Allen H04W 12/04
 2017/0212213 A1 7/2017 Kishigami
 2017/0254879 A1 9/2017 Tokieda, I et al.

(56) **References Cited**

U.S. PATENT DOCUMENTS

- 5,151,702 A * 9/1992 Urkowitz G01S 13/284
 342/116
 5,289,188 A * 2/1994 Chudleigh, Jr. G01S 13/288
 342/132
 8,040,935 B2 * 10/2011 Song H04B 1/707
 375/146
 8,548,033 B2 * 10/2013 Nemeth H04L 27/0014
 375/219
 9,094,004 B2 * 7/2015 Hsieh H03K 19/017509
 9,571,317 B1 * 2/2017 Kossin H04L 27/20
 2008/0100499 A1 * 5/2008 Nishimura G01S 13/34
 342/75
 2012/0163426 A1 * 6/2012 Nemeth H04L 27/0014
 375/219
 2012/0223855 A1 * 9/2012 Kurono G01S 7/2925
 342/146
 2013/0079060 A1 * 3/2013 Pivit H01Q 3/267
 455/561
 2013/0113653 A1 * 5/2013 Kishigami G01S 7/285
 342/189
 2013/0120185 A1 * 5/2013 Kishigami G01S 7/2813
 342/146
 2014/0111367 A1 * 4/2014 Kishigami G01S 7/2813
 342/21

FOREIGN PATENT DOCUMENTS

- JP 2008-20221 A 1/2008
 JP 2008-236740 A 10/2008
 JP 2014-20970 A 2/2014
 JP 2016-50778 A 4/2016
 JP 2017032522 A 2/2017

OTHER PUBLICATIONS

Japanese Notice of Reasons for Refusal, dated Jan. 5, 2021, for Japanese Application No. 2017-043079, 10 pages. (with machine translation).
 S. Z. Budisin, "New complementary pairs of sequences," Electronics Letters, vol. 26, No. 13, Jun. 21, 1990, p. 881-883.
 Yoshimasa Egashira et al., "A novel IQ imbalance compensation method with pilot-signals for OFDM system", IEICE transaction B, vol. J91-B, No. 5, May 1, 2008, pp. 558-565 (Partial Translation).
 Eric Spano et al., "Sequences of complementary codes for the optimum decoding of truncated ranges and high sidelobe suppression factors for ST/MST radar systems", IEEE Transactions on Geoscience and Remote Sensing, vol. 34, No. 2, Mar. 1, 1996, pp. 330-345.

* cited by examiner

FIG. 1

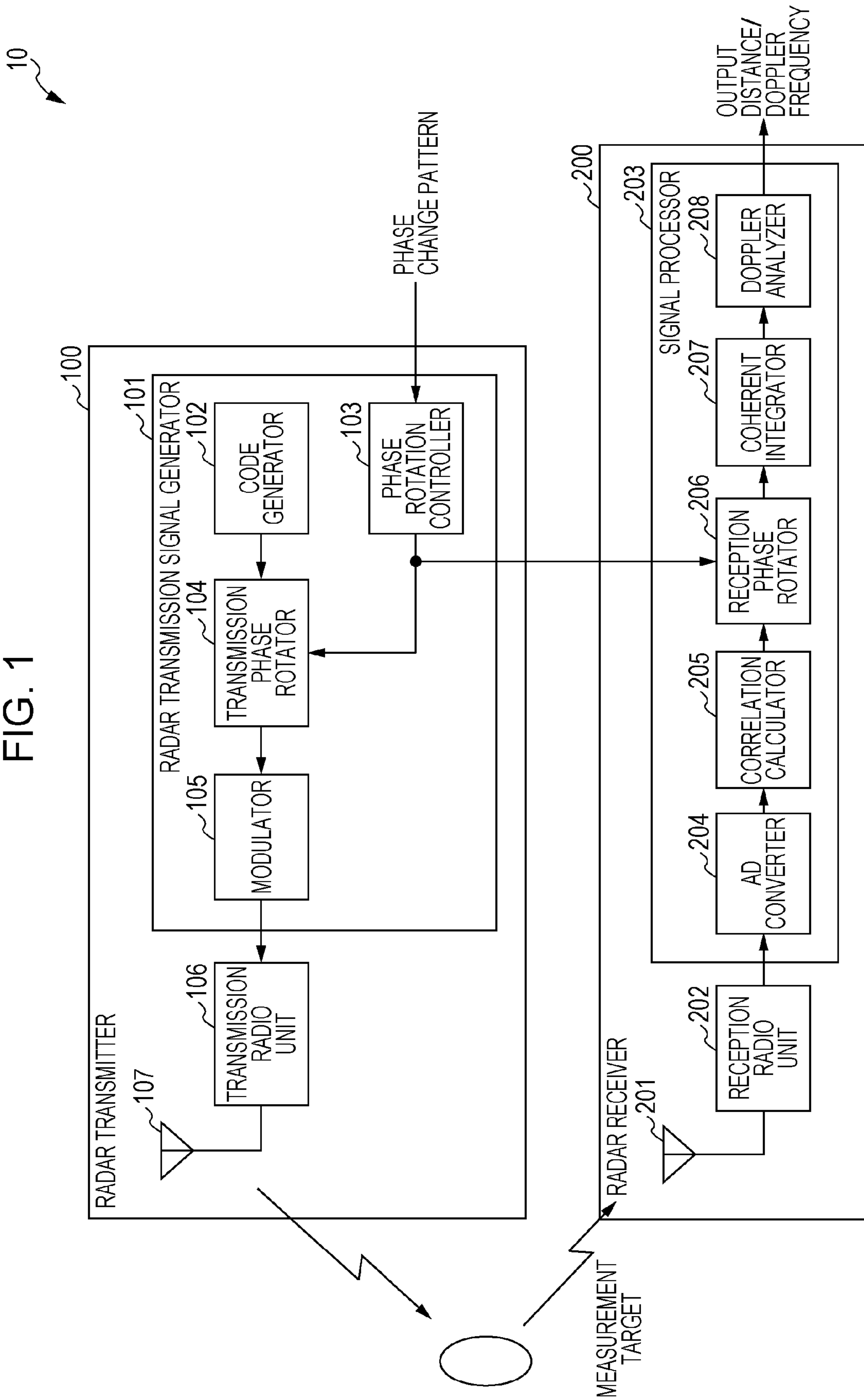

FIG. 2

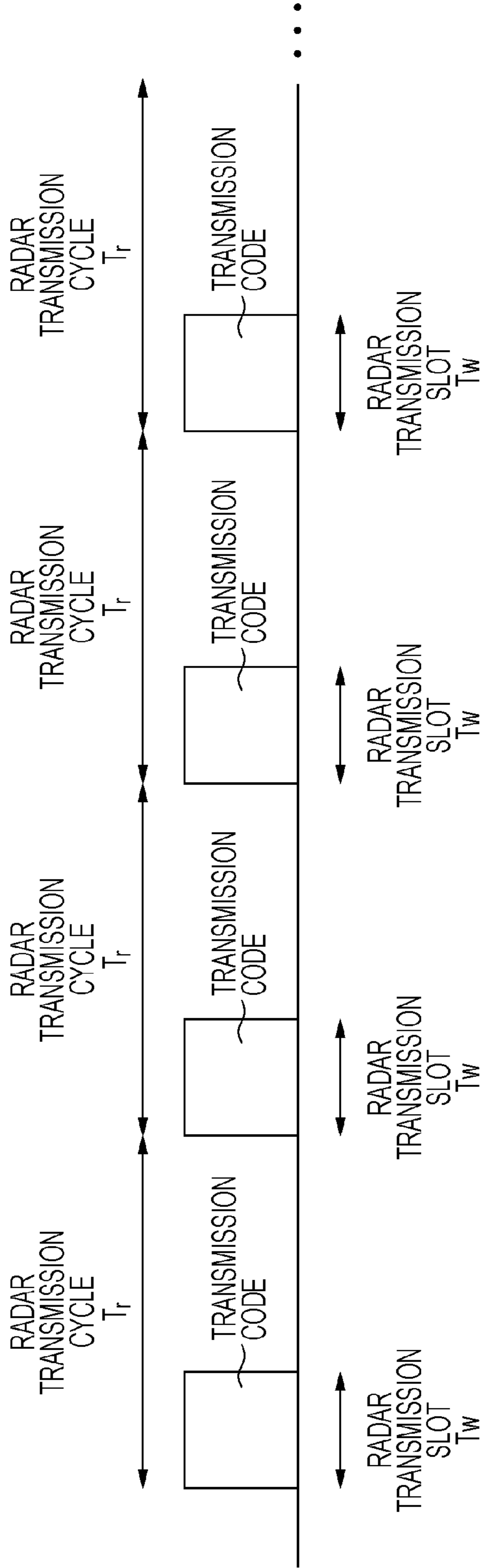

FIG. 3

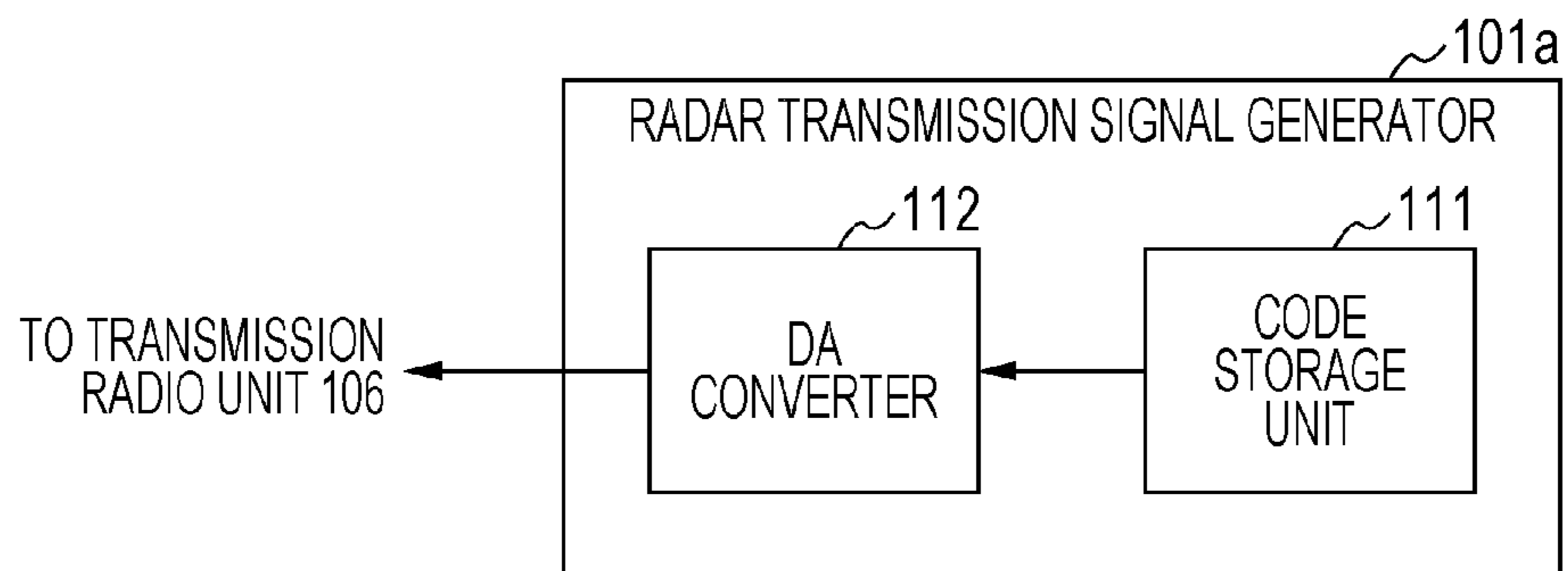

FIG. 4A

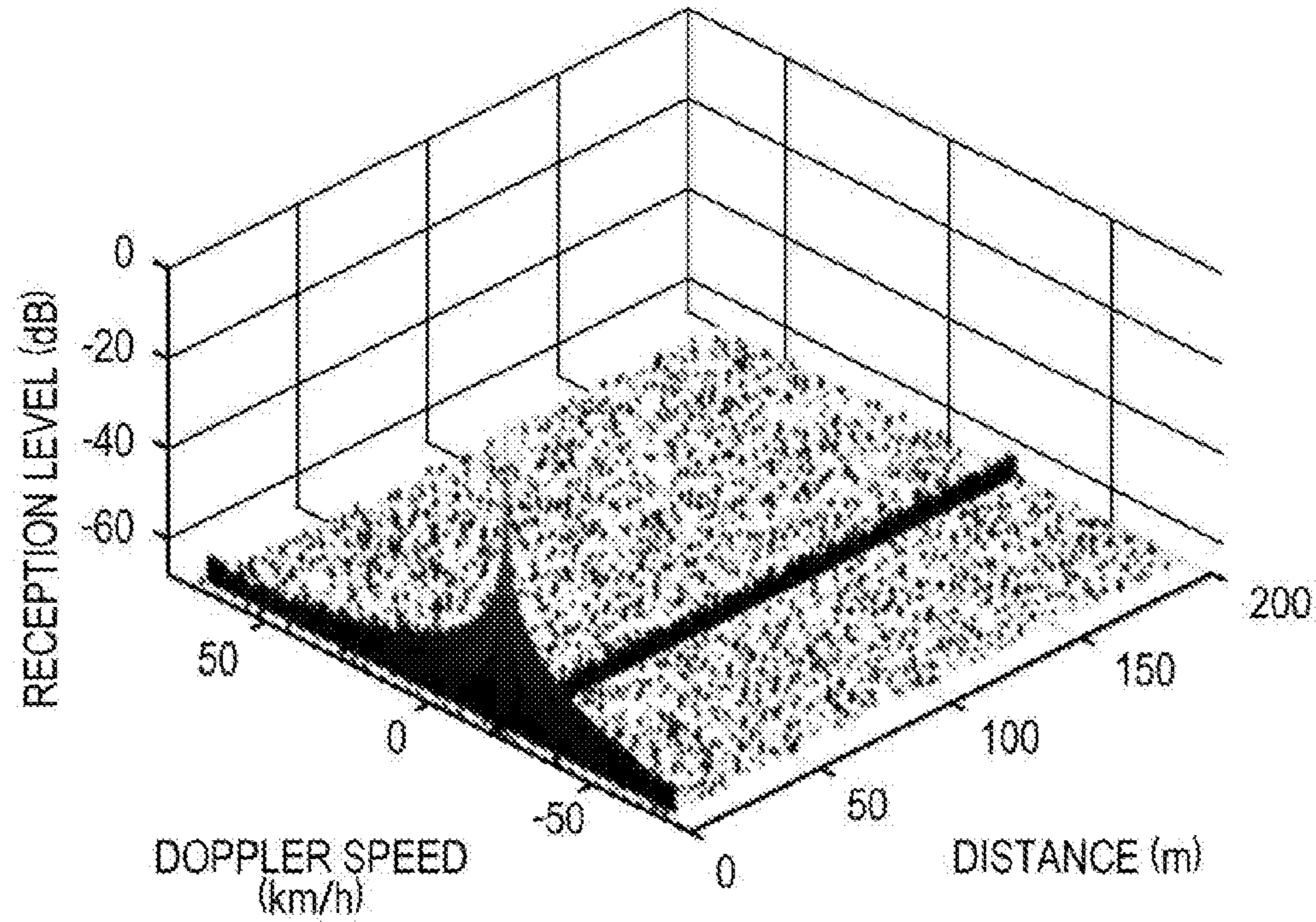

FIG. 4B

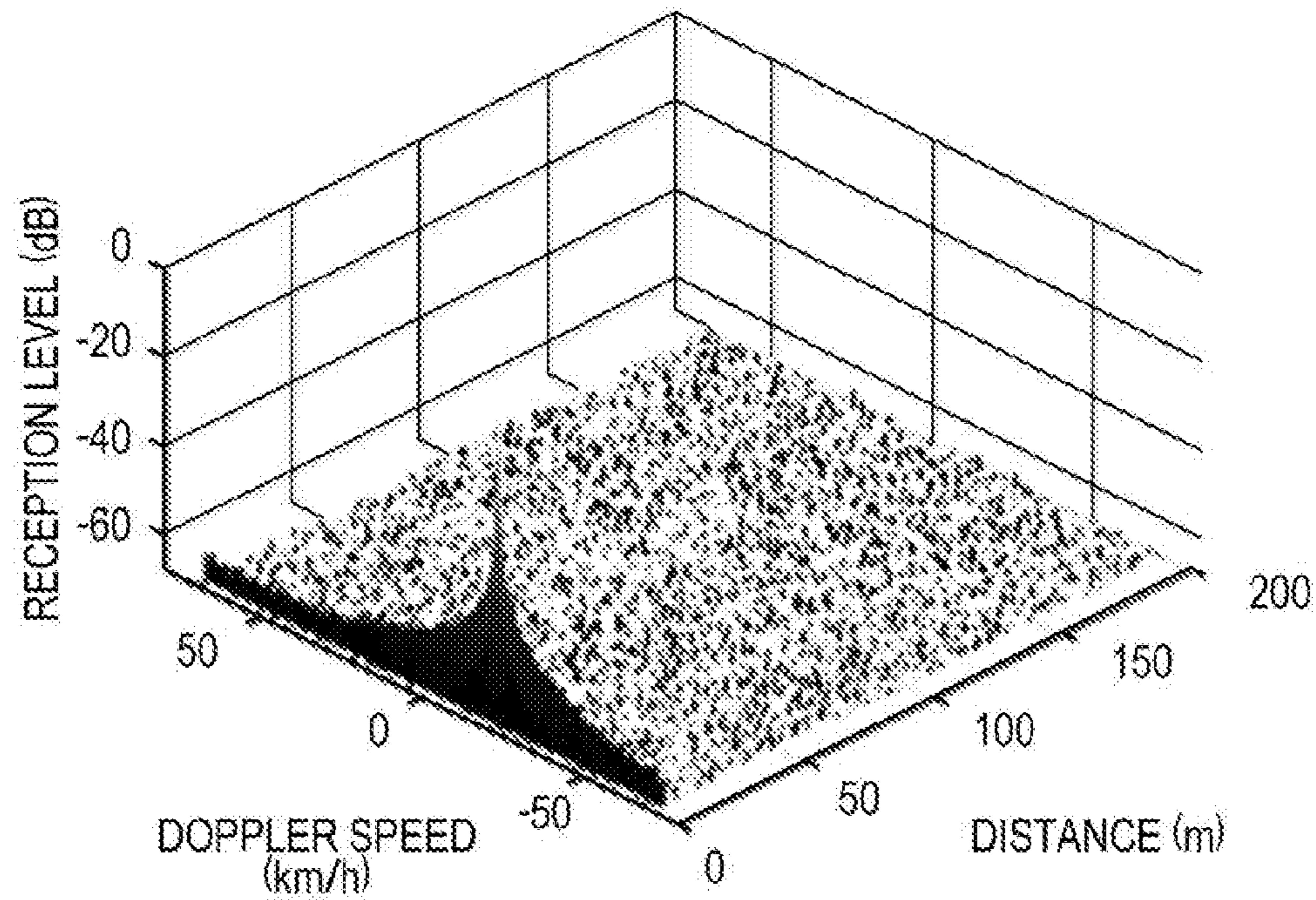
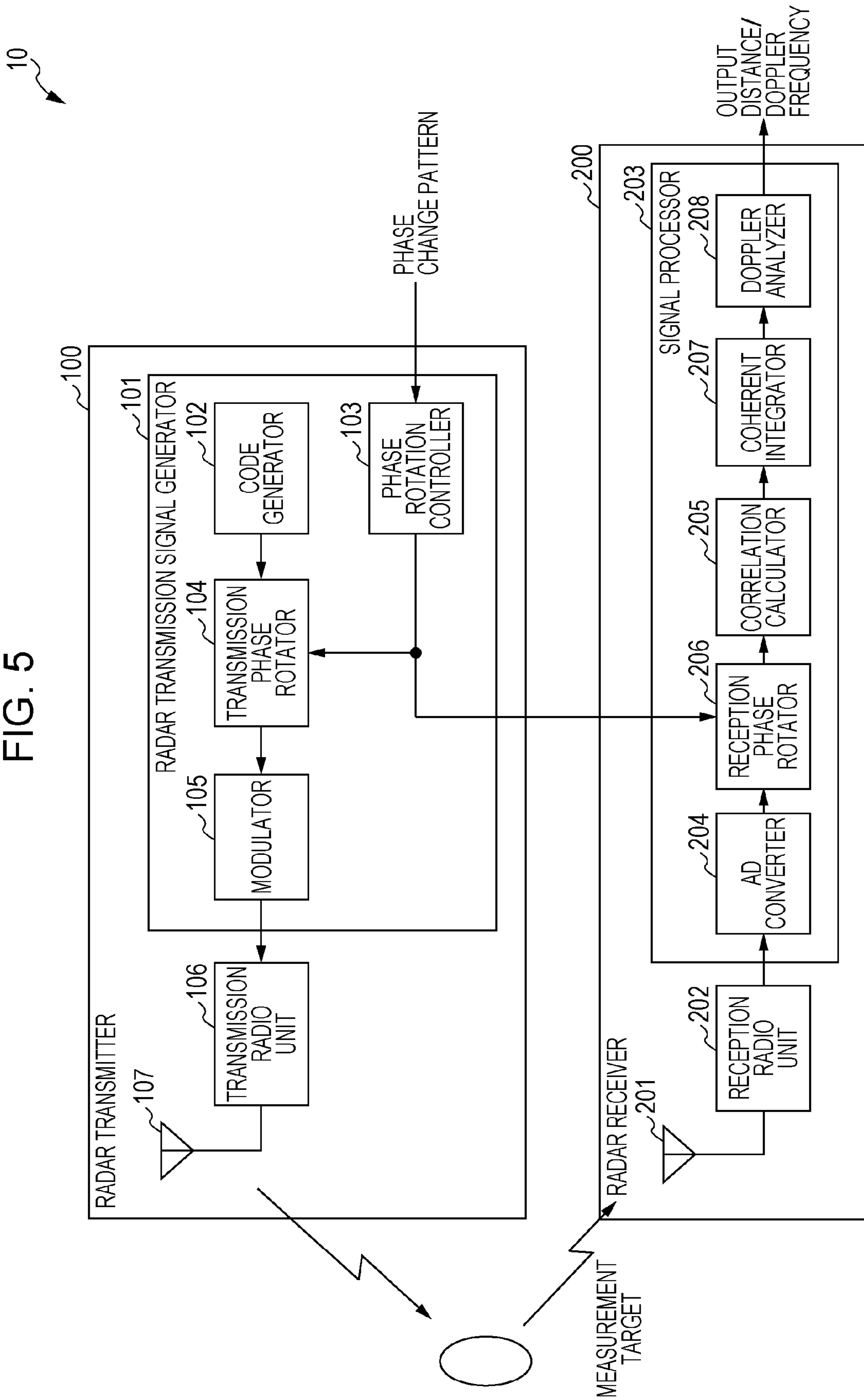

FIG. 5



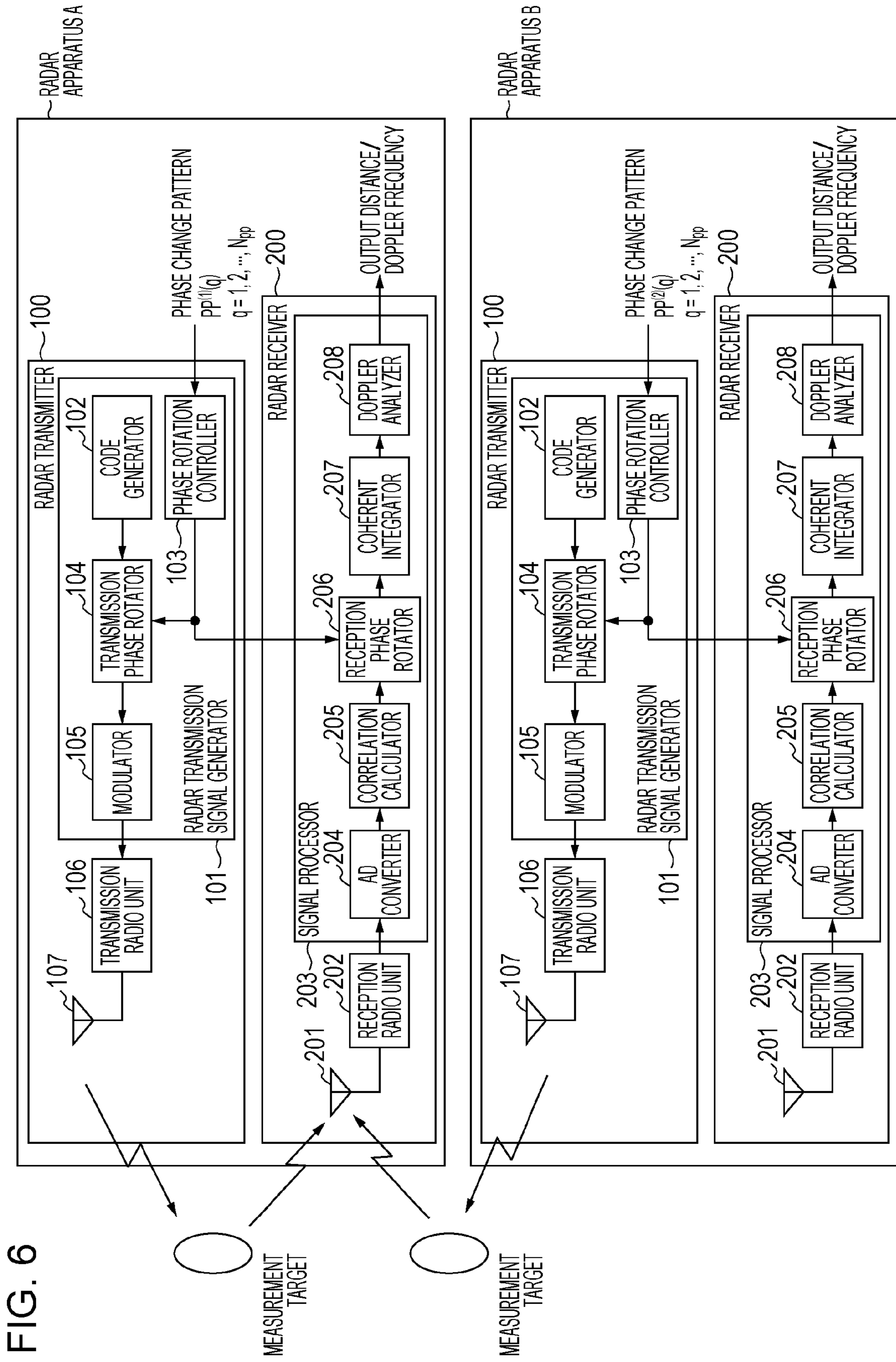

FIG. 7

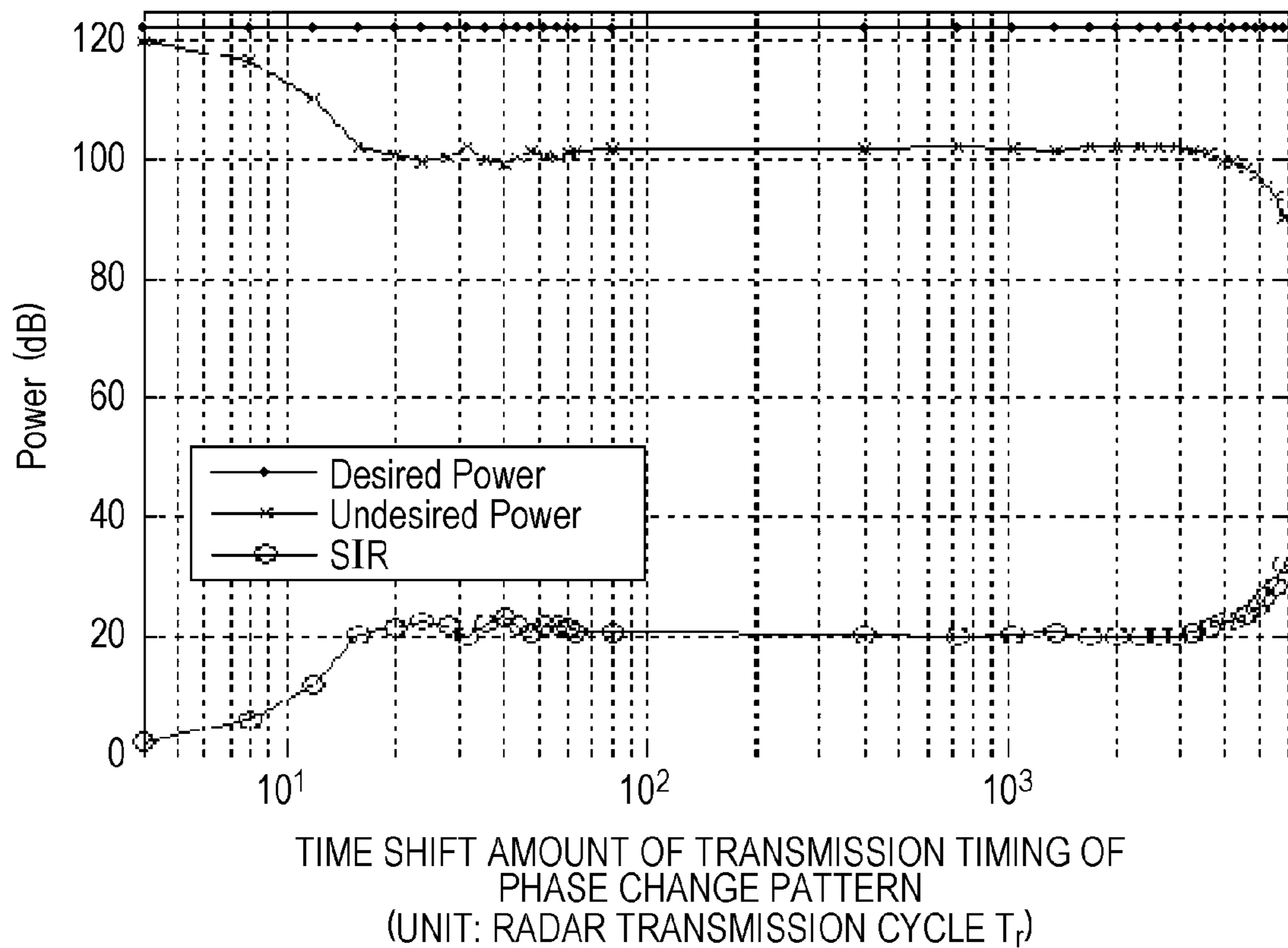
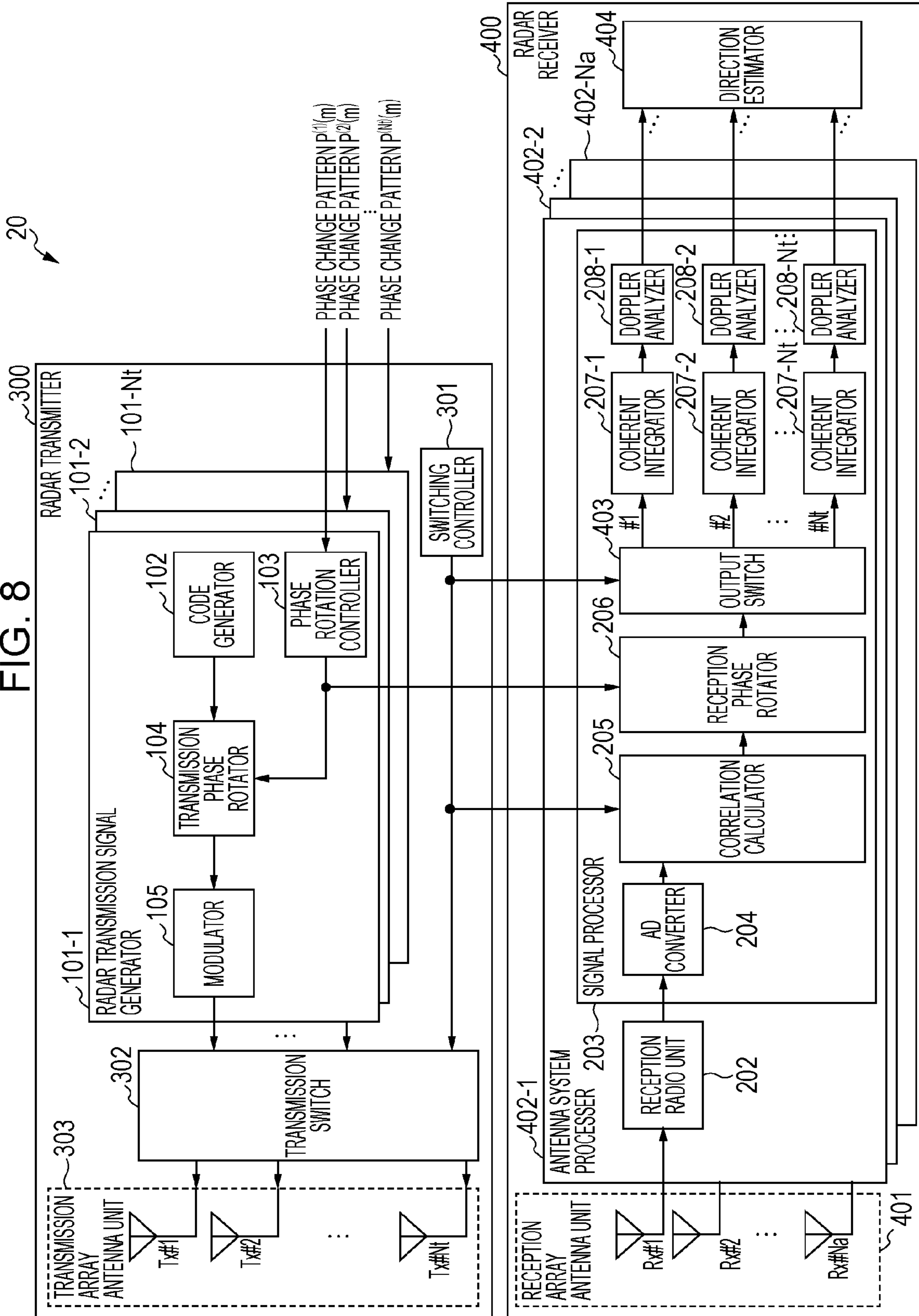

FIG. 8



RADAR APPARATUS AND RADAR METHOD

Matter enclosed in heavy brackets [] appears in the original patent but forms no part of this reissue specification; matter printed in italics indicates the additions made by reissue; a claim printed with strikethrough indicates that the claim was canceled, disclaimed, or held invalid by a prior post-patent action or proceeding.

BACKGROUND

1. Technical Field

The present disclosure relates to a radar apparatus and a radar method.

2. Description of the Related Art

In recent years, studies have been advancing on radar apparatuses using short-wavelength radar transmission signals, including microwaves or millimeter waves, which may achieve high resolution. On the other hand, in order to improve the safety outdoors, there is a demand for development of radar apparatuses (wide-angle radar apparatuses) to detect objects (targets) including not only vehicles but also pedestrians in a wide range of angle.

As such radar apparatuses, pulse-compression radar apparatuses are known, for example. In the case of detection of vehicles and pedestrians by a pulse-compression radar, reflection waves from pedestrians are much weaker than reflection waves from vehicles. Accordingly, the radar transmitter is required to have a transmission configuration to transmit pulse-compression waves with low range sidelobes, and the radar receiver is required to have a reception configuration including a wide dynamic range of reception.

For example, it is known to use, as the pulse compression codes to provide low-level range sidelobe characteristics, Barker codes, PN sequence codes, complementary codes, or the like. The following description is given of a case using complementary codes as an example. Complementary codes are composed of paired codes (hereinafter, referred to as complementary codes a_n and b_n . Herein, $n=1, \dots, L$. L is a code length). The autocorrelation operations of the two codes are expressed by the following expressions (1) and (2), respectively.

$$R_{aa}(\tau) = \sum_{n=1}^L a_n a_{n+\tau}^* \quad (1)$$

$$R_{bb}(\tau) = \sum_{n=1}^L b_n b_{n+\tau}^* \quad (2)$$

In expressions (1) and (2), $a_n=0$ and $b_n=0$ where $n>L$ and $n<1$. When the results of the autocorrelation operations for the two codes are added up with the same shift time τ , the correlated value is 0 where τ is not 0 as illustrated in the following expression (3). It means that the complementary code has zero range sidelobes thereof.

$$\begin{cases} R_{aa}(\tau) + R_{bb}(\tau) \neq 0, & \text{when } \tau = 0 \\ R_{aa}(\tau) + R_{bb}(\tau) = 0, & \text{when } \tau \neq 0 \end{cases} \quad (3)$$

One of known pulse compression radars transmit the complementary codes a_n and b_n every predetermined radar transmission cycle in a time division manner.

One of the methods to generate complementary codes is disclosed in Budisin, S. Z., "New complementary pairs of sequences," Electron. Lett., 1990, 26, (13), pp. 881-883). According to this literature, complementary codes with code lengths $L=4, 8, 16, 32, \dots, 2^P$ are sequentially generated based on codes $A=[a_1, a_2]=[1, 1]$ and $B=[b_1, b_2]=[1, -1]$, which are composed of elements 1 or -1 and have complementarity, for example. Pulse compression radars repeatedly transmit the aforementioned pulse compression codes a predetermined number of times in every radar transmission cycle to increase the reception level of radar reflection waves.

When the aforementioned pulse compression radar is configured to use a radio frequency band (RF band), such as millimeter-waves, an RF circuit and an analogue baseband circuit of the radar transmitter or receiver of the radar apparatus include circuit errors, which results in a lower radar detection performance (or low radar ranging performance) compared with the ideal characteristics obtained when no circuit errors are included.

SUMMARY

One non-limiting and exemplary embodiment provides a radar apparatus and a radar method in which the radar detection performance is prevented from degrading due to circuit errors.

In one general aspect, the techniques disclosed here feature a radar apparatus, including: a radar transmitter which transmits a radar signal in a predetermined transmission cycle; and a radar receiver which receives a reflection wave signal being a reflection of the radar signal on a target. The radar transmitter includes a phase rotation controller which randomly varies a pattern of a phase rotation amount every period corresponding to a plurality of transmission cycles, the pattern being to be applied to the radar signal within a period; and a transmission phase rotator which assigns a first phase rotation to the radar signal in accordance with the pattern. The radar receiver includes a reception phase rotator which assigns a second phase rotation in a direction opposite to a direction of the first phase rotation to the reflection wave signal in accordance with the pattern.

It should be noted that general or specific embodiments may be implemented as a system, a method, an integrated circuit, a computer program, a storage medium, or any selective combination thereof.

According to the aspect of the disclosure, it is possible to suppress degradation of the radar detection performance due to circuit errors.

Additional benefits and advantages of the disclosed embodiments will become apparent from the specification and drawings. The benefits and/or advantages may be individually obtained by the various embodiments and features of the specification and drawings, which need not all be provided in order to obtain one or more of such benefits and/or advantages.

BRIEF DESCRIPTION OF THE DRAWINGS

FIG. 1 is a block diagram illustrating a configuration example of a radar apparatus according to Embodiment 1 of the disclosure;

FIG. 2 is a diagram illustrating an example of a radar transmission signal according to the Embodiment 1 of the disclosure;

FIG. 3 is a block diagram illustrating another configuration of a radar transmission signal generator according to the Embodiment 1 of the disclosure;

FIG. 4A is a diagram illustrating an example of a computer simulation result of an output of a Doppler analyzer when phase inversion is not performed;

FIG. 4B is a diagram illustrating an example of a computer simulation result of an output of a Doppler analyzer according to the Embodiment 1 of the disclosure;

FIG. 5 is a diagram illustrating another configuration example of the radar apparatus according to the Embodiment 1 of the disclosure;

FIG. 6 is a block diagram illustrating a configuration example of a radar apparatus according to Embodiment 2 of the disclosure;

FIG. 7 is a diagram illustrating an example of a computer simulation result of an output of a Doppler analyzer according to the Embodiment 2 of the disclosure; and

FIG. 8 is a block diagram illustrating a configuration example of a radar apparatus according to Embodiment 3 of the disclosure.

DETAILED DESCRIPTION

Circuit errors that can occur in a radar apparatus are: IQ mismatch, DC offsets, and the like in a quadrature modulator and a quadrature demodulator; phase noise in a frequency converter; and quantization noise in AD and DA converters.

When the DC offset is included as a circuit error, a phenomenon generating a noise level higher than a case free of the circuit error occurs. For this reason, when a wave reflected from the target is lower than the noise level, the radar apparatus is unable to detect the target. This leads to drop of the detection ratio and deterioration of radar detection performance.

To solve the problem, methods of removing the DC offset by a circuit configuration including a radar transmitter or a radar receiver have been proposed conventionally. Specifically, Japanese Patent Application Publication No. 2-243022 discloses a configuration with a bypass filter arranged for discrete data outputted from an AD converter to remove the DC offset. Japanese Patent Application Publication No. 2000-338226 discloses a configuration with a bandpass filter arranged in an input stage of an AD converter to remove the DC offset. Moreover, a circuit configuration to correct an IQ imbalance circuit error is disclosed in Egashira, et al., "A novel IQ imbalance compensation method with pilot-signals for OFDM system," IEICE transaction B, Vol. J91-B, No. 5, pp. 558-565, 2008.

However, the related arts disclosed by Japanese Patent Application Publication Nos. 2-243022 and 2000-338226 need installation of a DC offset removal circuit or a correction circuit for the IQ imbalance circuit error, which complicates the circuit configuration. Also, in a case where a bypass filter or bandpass filter is provided for DC offset removal, a desired radar reflected wave component other than the DC offset component may be weakened or a filter response may cause an amplitude distortion or a phase distortion, and thereby radar detection performance deteriorates.

Even in a configuration with the DC offset removal circuit, if the DC offset component or the IQ imbalance component is not removed completely and thereby a circuit error component remains, the circuit error component is also

integrated by a coherent integration processing in a radar reception processing, and this results in deteriorating radar detection performance. For example, if even a small amount of the residual circuit error component is included, the residual component increases to 30 to 40 dB due to integration effects. This necessitates a high precision error detection mechanism, which complicates a hardware configuration of the radar apparatus.

Meanwhile, a radar apparatus that cancels the reception DC offset component by transmitting a code including a combination of phase modulations in a plurality of pulse transmission cycles to subject the reflected wave to the coherent integration processing is disclosed in E. Spano and O. Ghebrebrhan, "Sequences of complementary codes for the optimum decoding of truncated ranges and high sidelobe suppression factors for ST/MST radar systems," IEEE Transactions on Geoscience and Remote Sensing, Vol. 34, No. 2, pp. 330-345, 1996.

As an example, a principle of canceling the reception DC offset component is illustrated hereinafter. In the principle, a code $A=[a_1, a_2, \dots, a_L]$ used for pulse compression and a code $-A=[-a_1, -a_2, \dots, -a_L]$ phase-inverted at 180 degrees from the code A are transmitted from a transmission side of a radar apparatus, and a reception side of the radar apparatus cancels the reception DC offset by the coherent integration.

Hereinafter, description is given on a case where there is no noise component and the sum of elements of the code A is not zero as shown in the following expression (4).

$$\sum_{n=1}^L a_n \neq 0 \quad (4)$$

Example 1: When Reception Signal of the Radar Reflection Wave Includes Reception DC Offset Component

(1-1) When transmitting the code A , reception signal $(\gamma A + \alpha_{Rx})$ of the code A including the reception DC offset component α_{Rx} and autocorrelation value obtained by autocorrelation operation with the code A are expressed by the following expression (5).

$$R_A(\tau) = \sum_{n=1}^L (\gamma a_n + \alpha_{Rx}) a_{n+\tau}^* = \gamma \sum_{n=1}^L a_n a_{n+\tau}^* + \alpha_{Rx} \sum_{n=1}^L a_n^* \quad (5)$$

In the expression (5), γ indicates a complex reception signal, and asterisk (*) indicates the complex conjugate operator.

(1-2) When transmitting the code $-A$, reception signal $(-\gamma A + \alpha_{Rx})$ of the code $-A$ including the reception DC offset component α_{Rx} and the autocorrelation value obtained by autocorrelation operation with the code $-A$ are expressed by the following expression (6).

$$R_{(-A)}(\tau) = \sum_{n=1}^L (-\gamma a_n + \alpha_{Rx})(-a_{n+\tau}^*) = \gamma \sum_{n=1}^L a_n a_{n+\tau}^* - \alpha_{Rx} \sum_{n=1}^L a_n^* \quad (6)$$

When the autocorrelation value (expression (5)) obtained in the above (1-1) only is subjected to the coherent integra-

5

tion processing on the reception side, two terms including the reception DC offset component α_{Rx} are integrated even when γ is zero (or even when radar reflection wave does not exist). For this reason, noise level (floor level) increases across entire distance range, and thereby radar detection performance deteriorates.

On the other hand, when autocorrelation values (expressions (5) and (6)) obtained in the above (1-1) and (1-2) are subjected to the coherent integration processing on the reception side, the reception DC offset component α_{Rx} may be canceled as shown in the expression (7).

$$R_A(\tau) + R_{(-A)}(\tau) = 2\gamma \sum_{n=1}^L a_n a_{n+\tau}^* \quad (7)$$

This inhibits increase of the noise level and suppresses deterioration of radar detection performance of the radar apparatus. In the same manner, the reception DC offset component α_{Rx} in a reception signal of the radar reflection wave including Doppler fluctuation may be canceled, and thereby increase of the noise level (floor level) may be inhibited and deterioration of radar detection performance may be suppressed.

Example 2: When Reception Signal of the Radar Reflection Wave not Including Doppler Fluctuation Includes Transmission DC Offset Component α_{Tx}

(2-1) When transmitting the code A, a reception signal $\gamma(A + \alpha_{Tx})$ including the transmission DC offset component α_{Tx} and an autocorrelation value obtained by autocorrelation operation with the code A are expressed by the following expression (8).

$$R_A(\tau) = \sum_{n=1}^L \gamma(a_n + \alpha_{Tx})a_{n+\tau}^* = \gamma \sum_{n=1}^L a_n a_{n+\tau}^* + \gamma \alpha_{Tx} \sum_{n=1}^L a_n^* \quad (8)$$

(2-2) When transmitting the code $-A$, a reception signal $-\gamma(A + \alpha_{Tx})$ including the transmission DC offset component α_{Tx} and an autocorrelation value obtained by autocorrelation operation with the code $-A$ are expressed by the following expression (9).

$$R_{(-A)}(\tau) = \sum_{n=1}^L \gamma(-a_n + \alpha_{Tx})(-a_{n+\tau}^*) = \gamma \sum_{n=1}^L a_n a_{n+\tau}^* - \gamma \alpha_{Tx} \sum_{n=1}^L a_n^* \quad (9)$$

When autocorrelation values (expressions (8) and (9)) obtained in the above (2-1) and (2-2) are subjected to the coherent integration processing on the reception side, the transmission DC offset component α_{Rx} is canceled in the same manner as the <example 1> where the reception DC α_{Rx} is included, and thereby increase of the noise level (floor level) may be inhibited and deterioration of radar detection performance may be suppressed.

As described in <Example 1> and <Example 2>, deterioration of radar detection performance may be suppressed by canceling the transmission DC offset component or the reception DC offset component.

However, even in the above method, when a transmission DC offset component (including a carrier leak component) exists in the radar transmitter and there is a Doppler fluctuation

6

in the radar reflection wave, the transmission DC offset component remains. This is because, in the above method, a cancellation error occurs due to Doppler fluctuation of the transmission DC offset component. Thus, noise level of the Doppler component included in a residual transmission DC offset component may increase, and thereby radar detection performance may deteriorate.

Hereinafter, a case where the Doppler fluctuation is included in the radar reflection wave is described.

Example 3: When Reception Signal of the Radar Reflection Wave Including Doppler Fluctuation Includes Transmission DC Offset Component α_{Tx}

Here, the Doppler fluctuation included in the radar reflection wave is “ $\exp(j2\pi f_d \times T_r) = \exp(j\Phi_d)$ ” (f_d : Doppler frequency, T_r : radar transmission cycle, provided that Doppler fluctuation in the code is deemed constant).

(3-1) When transmitting the code A, a reception signal $\gamma(A + \alpha_{Tx}) \exp(j\Phi_d)$ including the transmission DC offset component α_{Tx} and an autocorrelation value obtained by autocorrelation operation with the code A are expressed by the following expression (10).

$$R_A(\tau) = \sum_{n=1}^L \gamma(a_n + \alpha_{Tx})a_{n+\tau}^* = \gamma \sum_{n=1}^L a_n a_{n+\tau}^* - \gamma \alpha_{Tx} \sum_{n=1}^L a_n^* \quad (10)$$

(3-2) When transmitting the code $-A$, a reception signal $-\gamma(A + \alpha_{Tx}) \exp(j\Phi_d)$ including the transmission DC offset component α_{Tx} and an autocorrelation value obtained by autocorrelation operation with the code $-A$ are expressed by the following expression (11).

$$R_{(-A)}(\tau) = \sum_{n=1}^L [\gamma(-a_n + \alpha_{Tx}) \exp(j\psi_d)](-a_{n+\tau}^*) = \quad (11)$$

$$\gamma \exp(j\psi_d) \sum_{n=1}^L a_n a_{n+\tau}^* - \gamma \alpha_{Tx} \exp(j\psi_d) \sum_{n=1}^L a_n^*$$

On the reception side, when autocorrelation values (expressions (10) and (11)) obtained in the above (3-1) and (3-2) are subjected to the coherent integration processing, two items including the transmission DC offset component α_{Tx} are integrated depending on γ .

$$R_A(\tau) + R_{(-A)}(\tau) = \gamma \{1 + \exp(j\psi_d)\} \sum_{n=1}^L a_n a_{n+\tau}^* + \gamma \alpha_{Tx} \{1 - \exp(j\psi_d)\} \sum_{n=1}^L a_n^* \quad (12)$$

In general, a coherent integration processing using the Doppler frequency analysis is applied to the reception processing of the radar reflection wave including the Doppler fluctuation. Thus, noise level (floor level) of a Doppler frequency component corresponding to two terms of the expression (12) increases, and thereby radar detection performance deteriorates. Reception power of the transmission DC offset component α_{Tx} is proportionate with $|\gamma \alpha_{Tx}|^2$. Thus, larger the reception power of the radar reflection wave, higher the noise level (floor level) and more deteriorating the radar detection performance.

Next, description is given on a method of inhibiting increase of the noise level (floor level) and suppressing

deterioration of radar detection performance without adding a high precision correction circuit for circuit error correction even when a pulse compression radar includes a transmission DC offset (carrier leak) and a reception DC offset.

In the above method of transmitting pulse compression codes to which phase modulation is applied in a plurality of pulse transmission cycles, when a transmission DC offset component (including a carrier leak component) exists in the radar transmitter, Doppler fluctuation in the radar reflection wave causes the transmission DC offset component to remain and thereby noise level of a specific Doppler component increases. In this case, the transmission DC offset component may be reduced by a method described below.

Specifically, this is a method in which the radar apparatus transmits codes A, -A, -A, and A in four radar transmission cycles respectively using the code A="a₁, a₂, . . . , a_L" used for pulse compression and the code -A="-a₁, -a₂, . . . , -a_L" phase-inverted from the code A from the transmission side, and the reception side correlates the codes to each other to perform coherent integration.

Hereinafter, this method is described specifically. In the same manner as the above, description is given on the case where there is no noise component and the sum of elements of the code A is not zero (see the expression (4)).

Example 4: When Reception Signal of the Radar Reflection Wave Including Doppler Fluctuation Includes Transmission DC Offset Component α_{Tx}

Here, the Doppler fluctuation included in the radar reflection wave is " $\exp(j2\pi f_d \times T_r) = \exp(j\Phi_d)$ " (f_d : Doppler frequency, T_r : radar transmission interval, provided that Doppler fluctuation in the code is deemed constant).

(4-1) When transmitting the code A, a reception signal $\gamma(A + \alpha_{Tx})$ including the transmission DC offset component α_{Tx} and an autocorrelation value obtained by autocorrelation operation with the code A are expressed by the following expression (13).

$$R_A^{(1)}(\tau) = \sum_{n=1}^L \gamma(a_n + \alpha_{Tx}) a_{n+\tau}^* = \gamma \sum_{n=1}^L a_n a_{n+\tau}^* + \gamma \alpha_{Tx} \sum_{n=1}^L a_n^* \quad (13)$$

(4-2) When transmitting the code -A, a reception signal $\gamma(-A + \alpha_{Tx}) \exp(j\Phi_d)$ of the code -A including the transmission DC offset component α_{Tx} and an autocorrelation value obtained by autocorrelation operation with the code -A are expressed by the following expression (14).

$$R_{(-A)}^{(1)}(\tau) = \sum_{n=1}^L \gamma[(-a_n + \alpha_{Tx}) \exp(j\psi_d)] (-a_{n+\tau}^*) = \gamma \exp(j\psi_d) \sum_{n=1}^L a_n a_{n+\tau}^* - \gamma \alpha_{Tx} \exp(j\psi_d) \sum_{n=1}^L a_n^* \quad (14)$$

(4-3) When transmitting the code -A, a reception signal $\gamma(-A + \alpha_{Tx}) \exp(j2\Phi_d)$ including the transmission DC offset component α_{Tx} and an autocorrelation value obtained by autocorrelation operation with the code -A are expressed by the following expression (15).

$$R_{(-A)}^{(2)}(\tau) = \sum_{n=1}^L \gamma[(-a_n + \alpha_{Tx}) \exp(j2\psi_d)] (-a_{n+\tau}^*) = \gamma \exp(j2\psi_d) \sum_{n=1}^L a_n a_{n+\tau}^* - \gamma \alpha_{Tx} \exp(j2\psi_d) \sum_{n=1}^L a_n^* \quad (15)$$

(4-4) When transmitting the code A, a reception signal $\gamma(A + \alpha_{Tx}) \exp(j3\Phi_d)$ of the code A including the transmission DC offset component α_{Tx} and an autocorrelation value obtained by autocorrelation operation with the code A are expressed by the following expression (16).

$$R_A^{(2)}(\tau) = \sum_{n=1}^L \gamma[(a_n + \alpha_{Tx}) \exp(j3\psi_d)] a_{n+\tau}^* = \gamma \exp(j3\psi_d) \sum_{n=1}^L a_n a_{n+\tau}^* + \gamma \alpha_{Tx} \exp(j3\psi_d) \sum_{n=1}^L a_n^* \quad (16)$$

On the reception side, when autocorrelation values (expressions (13) to (16)) obtained in the above (4-1) to (4-4) are subjected to the coherent integration processing, two items including the transmission DC offset component α_{Tx} are integrated as shown in the following expression (17) depending on γ .

$$R_A^{(1)}(\tau) + R_{(-A)}^{(1)}(\tau) + R_{(-A)}^{(2)}(\tau) + R_A^{(2)}(\tau) = \{1 + \exp(j\psi_d) + \exp(2j\psi_d) + \exp(3j\psi_d)\} \gamma \sum_{n=1}^L a_n a_{n+\tau}^* + \alpha_{Tx} \{1 - \exp(j\psi_d) - \exp(2j\psi_d) + \exp(3j\psi_d)\} \gamma \sum_{n=1}^L a_n^* + \{1 + \exp(j\psi_d) + \exp(2j\psi_d) + \exp(3j\psi_d)\} \gamma \sum_{n=1}^L a_n a_{n+\tau}^* + \alpha_{Tx} \{1 - \exp(j\psi_d)\} \{1 - \exp(2j\psi_d)\} \gamma \sum_{n=1}^L a_n^* \quad (17)$$

In the expression (17), Doppler phase fluctuation Φ_d in a range smaller than $\tau\epsilon$ is " $\oplus 1 - \exp(j2\Phi_d) < 1$ ". Thus, the residual component of the transmission DC offset may be reduced more than the case shown in <Example 3> (see the expression (12)). However, even in the case of <Example 4>, the residual component of the transmission DC offset may not be canceled completely.

As described above, the coherent integration processing using the Doppler frequency analysis is applied to the reception processing of the radar reflection wave included in the Doppler fluctuation. This increases noise level (floor level) of the Doppler frequency component including a residual transmission DC offset component (two terms of expression (17)), and thereby radar detection function deteriorates. For example, as described in <Example 4>, the transmission side transmits codes A, -A, -A, and A in each of four radar transmission cycles, and the reception side performs correlation reception processing of the radar reflection wave by the transmission codes, subjects each pair of transmission codes (A, -A) canceling the reception DC offset to the coherent integration processing in each of two radar transmission cycles, and performs Doppler frequency analysis of the output thereof. In this case, noise level (floor level) of the Doppler frequency component included in the

residual transmission DC offset component increases, and thereby radar detection function deteriorates.

Here, in the Doppler frequency analysis, the residual transmission DC offset component increases noise level (floor level) of a specific frequency component since output of the coherent integration processing has a fixed phase fluctuation.

To solve this problem, according to one aspect of the disclosure, the reception side applies a random phase fluctuation to the output of the coherent integration processing for a pair of transmission codes (A, -A) that cancel the reception DC offset such that output of the coherent integration processing does not have a fixed phase fluctuation.

Specifically, when performing the coherent integration processing using the Doppler frequency analysis on the reception side, the radar apparatus according to one aspect of the disclosure randomly changes over to a phase-inverted code (code with the phase changed by π) for each pair of a plurality of transmission codes that cancels the reception DC offset (in the cases of above <Example 1> to <Example 4>, codes corresponding to A and -A which are transmitted in two radar transmission cycles) such that the Doppler frequency fluctuation does not become a stationary phase shift amount (phase change amount).

This varies the phase fluctuation of the output of coherent integration processing to the radar reflection wave for each of the pair of transmission codes, and thereby the residual transmission DC offset component may be whitened in the Doppler frequency region. This inhibits increase of noise level of a specific Doppler frequency component and suppresses deterioration of radar detection function.

Hereinafter, a description is given of embodiments according to an aspect of the disclosure in detail with reference to the drawings. In the embodiments, the same constituent elements are given the same reference numerals, and the description thereof is redundant and omitted.

Embodiment 1

[Configuration of Radar Apparatus]

FIG. 1 is a block diagram illustrating the configuration of a radar apparatus 10 according to Embodiment 1.

The radar apparatus 10 includes a radar transmitter 100 and a radar receiver 200.

The radar transmitter 100 generates a high frequency (radio frequency) radar signals (radar transmission signals). The radar transmitter 100 transmits the radar transmission signals in each predetermined transmission cycle.

The radar receiver 200 receives a reflection wave signal which is a reflection of the radar transmission signal on the measurement target. The radar receiver 200 performs processing in synchronization with the radar transmitter 100 using a reference signal (not illustrated), for example. The radar receiver 200 processes the received reflection wave signal for detection of the presence of the target, direction estimation, and the like, for example. The measurement target is an object to be detected by the radar apparatus 10 and includes vehicles (including four or two wheel vehicles) or human beings, for example.

[Configuration of Radar Transmitter 100]

The radar transmitter 100 includes a radar transmission signal generator 101, a transmission radio unit 106, and a transmission antenna 107.

The radar transmission signal generator 101 modulates a code of a code length L to generate a baseband radar transmission signal (a pulse compression signal) every radar transmission cycle (T_r).

The radar transmission signal generator 101 operates based on transmission reference clocks, the frequency of which is a predetermined multiple of the frequency of the reference signal (not illustrated). Hereinafter, the transmission reference clock frequency is indicated by f_{Tab} . Herein, the radar transmission cycle ($T_r = N_r \times (1/f_{Tab})$) is an integer N_r times a discrete time interval ($1/f_{Tab}$) which is determined by the transmission reference clock frequency f_{Tab} as the predetermined multiple of the reference signal frequency.

The radar transmission signal generator 101 includes a code generator 102 a phase rotation controller 103, a transmission phase rotator 104, and a modulator 105.

Specifically, the code generator 102 generates a transmission code of the code length L every radar transmission cycle (T_r). More specifically, the code generator 102 generates a transmission code Code(m) of the code length L in the m-th radar transmission cycle.

Hereinafter, each element of the transmission code(m) is represented as $C_n(m)$. Specifically, the transmission code Code(m) is composed of L elements $\{C_1(m), C_2(m), \dots, C_L(m)\}$. The transmission code element $C_n(m)$ composes of two values such as $\{-1, 1\}$ and four values such as $\{1, -1, -j, j\}$. Herein, j indicates the imaginary unit. Moreover, $n=1, 2, \dots, L$, and $m=1, 2, \dots, Q$. Q indicates the number of radar transmission cycles taken by the radar apparatus 10 to measure the range, the Doppler frequency, the direction of arrival, and the like.

The transmission codes can be Barker codes, complementary codes, M-sequence codes, Gold codes, and the like, that contribute to low range sidelobe characteristics, for example. The transmission codes can be a combination of plural types of codes. The transmission code in each radar transmission cycle may be an identical code or a different code. Alternatively, a plurality of transmission codes may be changed over in each transmission cycle.

For unit period defined by a plurality (N_e) of radar transmission cycles ($=N_e \times T_r$), the phase rotation controller 103 outputs phase rotation amounts signal to the transmission phase rotator 104 and a radar receiver 200 (reception phase rotator 206) in order to assign a phase rotation of an integral multiple of 2π ($2\pi N_s$) to the transmission codes within the plurality (N_e) of radar transmission cycles. Here, N_e is an integer larger than 1, and N_s is an integer larger than 1.

For the period of the plurality (N_e) of radar transmission cycles ($=N_e \times T_r$), the phase rotation controller 103 outputs the phase rotation amount signals such that a predetermined phase shift amount (phase change amount) is achieved between the radar transmission cycles. For example, the phase rotation controller 103 outputs the phase rotation amount signal that cyclically assigns phase rotation amounts $\varphi \times 0, \varphi \times 1, \varphi \times 2, \dots, \varphi \times (N_e - 1)$ to the respective radar transmission cycles (T_r). Here, $\varphi = 2\pi N_s / N_e$. For example, when $N_e = 4$ and $N_s = 1$, the phase shift amount φ in each of radar transmission cycles (T_r) is $\pi/2$. In this case, phase rotation amounts outputted in the respective 4 ($=N_e$) radar transmission cycles (T_r) are, for example, 0, $\pi/2$, π , and $3\pi/2$.

When a complementary code is used as the transmission code (including a case where a plurality of complementary codes are transmitted in combination like a Spano code), the phase shift amount to a pair of codes constituting the complementary code is zero. More specifically, the same phase rotation is assigned to a pair of codes constituting the complementary code. This provides an effect of maintaining high sidelobe suppression characteristics of the complementary code.

11

For example, when using the complementary code, the phase rotation controller **103** outputs the phase rotation amount signal that cyclically assigns a phase rotation amount $\varphi \times 0, \varphi \times 0, \varphi \times 1, \varphi \times 1, \varphi \times 2, \varphi \times 2, \dots, \varphi(N_e-1), \varphi(N_e-1)$ to every even number (N_e) of radar transmission cycles (T_r). Here, $\varphi = 2\pi N_s / (N_e/2) = 4\pi N_s / N_e$. For example, when $N_e = 8$ and $N_s = 1$, the phase shift amount φ is $\pi/2$. In this case, a phase rotation amount outputted in every 8 ($=N_e$) radar transmission cycles (T_r) is, for example, $0, 0, \pi/2, \pi/2, \pi, \pi, 3\pi/2, 3\pi/2$.

When the phase shift amount φ is $\pi/2$, phase rotation may be implemented by replacing signal components I and Q with each other (with conversion of positive and negative codes to each other). Thus, the transmission phase rotator **104** needs no multiplier.

Also, when $N_e/N_s > 2$ (in the case of the complementary code, $N_e/N_s > 4$) is set, an effect of canceling even DC offset component including signal components I and Q may be obtained.

Further, for unit period defined by a plurality (N_e) of radar transmission cycles ($=N_e \times T_r$), the phase rotation controller **103** outputs phase rotation amount change signals controlling the phase rotation amount in accordance with a predetermined phase change pattern to the transmission phase rotator **104** and the radar receiver **200** (reception phase rotator **206**). In other words, every period ($N_e \times T_r$), the phase rotation controller **103** changes a pattern of a phase rotation amount to be applied to the radar transmission signal within the period ($=N_e \times T_r$) corresponding to a plurality (N_e) of radar transmission cycles.

Here, a random pattern fluctuating phase rotation may be used as a phase change pattern. For example, the phase rotation controller **103** controls the phase rotation amount using a pseudo random code (PN code), a M-sequence code, a gold code as a phase change pattern in accordance with the code polarity of respective codes of the phase change pattern.

By way of example, the phase change pattern comprises N_{pp} pieces of elements, and each of the elements comprises two values such as $\{-1, 1\}$. Hereinafter, elements of the phase change pattern are represented by $PP(q)$. Here, $q=1, 2, \dots, N_{pp}$. The phase rotation controller **103** sequentially reads elements $PP(q)$ of the phase change pattern and repeatedly outputs a value of the same element over the N_e radar transmission cycles ($=N_e \times T_r$). More specifically, a phase rotation amount change signal $PC(m)$ outputted by the phase rotation controller **103** in an m -th radar transmission cycle is represented by the following expression (18).

$$PC(m) = PP(\text{floor}[(m-1)/N_e] + 1) \quad (18)$$

Here, $m=1, \dots, N_e \times N_d$. N_d is a parameter defined by the Doppler analyzer **208** described later. When the number of elements N_{pp} of the phase change pattern is less than Q radar transmission cycles ($=N_e \times N_d$), the phase rotation controller **103** cyclically reads the phase change pattern in the Q radar transmission cycles.

More specifically, the phase change pattern is set such that each element $PP(q)$ is randomly changed for each of a plurality (N_e) of radar transmission cycles (T_r).

The transmission phase rotator **104** assigns phase rotation to a transmission code outputted from a code generator **102** based on the phase rotation amount signal and the phase rotation amount change signal instructed by the phase rotation controller **103**. The transmission phase rotator **104** outputs the transmission code assigned with phase rotation to the modulator **105**. For example, as shown in the following expression (19), the transmission phase rotator **104**

12

outputs a signal $GP(m)$ obtained by assigning phase rotation to the transmission code $Code(m)$ outputted from the code generator **102** in an m -th radar transmission cycle.

$$GP(m) = PC(m) \exp[j\{(m-1) \bmod N_e\} \varphi] Code(m) \quad (19)$$

Thus, the transmission phase rotator **104** assigns phase rotation to the transmission code (radar transmission signal) in accordance with the phase change pattern ($PC(m)$).

As described above, when the transmission code is a complementary code, the phase is not shifted (that is, assigning the same phase rotation) between codes constituting a pair of complementary codes to provide an effect of maintaining a characteristic (high sidelobe suppression characteristics) of canceling the distance sidelobe between codes constituting the pair of complementary codes. More specifically, as shown in the following expression (20), when the transmission code is a complementary code, the transmission phase rotator **104** outputs the signal $GP(m)$ obtained by assigning phase rotation to the transmission code $Code(m)$ such that the phase shift between two transmission cycles in which codes constituting a pair of complementary codes are transmitted becomes zero.

$$GP(m) = PC(m) \exp[j\{\text{floor}((m-1)/2) - 1 \bmod N_e\} \varphi] Code(m) \quad (20)$$

The modulator **105** performs pulse modulation (amplitude modulation (ASK: amplitude shift keying) or phase modulation (PSK: phase shift keying) to the transmission code outputted from the transmission phase rotator **104**, and outputs the modulation signal (radar transmission signal) to a transmission radio unit **106**.

For example, when the modulator **105** uses phase modulation (PSK), phase modulation of the transmission code compose of two values such as $\{-1, 1\}$ is BPSK, phase modulation of the transmission code compose of four values such as $\{1, -1, -j, j\}$ is four-phase PSK, and a predetermined modulation symbol on the IQ phase plane is allocated.

The modulator **105** outputs modulation signal limited within a predetermined band by passing a modulation signal of the modulated transmission code through a band limiting filter (not illustrated).

The modulated signal $G(n_s)$ is represented as the following expression (21) where $I(n_s)$ is the In-phase component of the modulated signal $G(n_s)$ and $Q(n_s)$ is the quadrature component.

$$G(n_s) = I(n_s) + jQ(n_s) \quad (21)$$

Herein, n_s is a natural number and represents a discrete time. The discrete time interval is $1/f_{Tab}$, and f_{Tab} is a transmission reference clock frequency which is a predetermined multiple of the reference signal frequency.

The modulator **105** modulates the transmission codes outputted from the transmission phase rotator **104** using samples corresponding to N_o transmission reference clocks per code element. For each transmission code of the code length L , $N_w (=N_o \times L)$ samples are included in a radar signal slot T_w . The no-signal slot ($T_r - T_w$) in each radar transmission cycle (T_r) includes samples corresponding to $N_u (=N_r - N_w)$ transmission reference clocks (see FIG. 2, for example). The modulated signal in the m -th radar transmission cycle is represented as the following expression (22).

$$G(N_r(m-1)+n) = I(N_r(m-1)+n) + jQ(N_r(m-1)+n) \quad (22)$$

The transmission radio unit **106** performs quadrature-modulation and frequency conversion for the signals outputted from the modulator **105** to generate the radar transmission signals in a carrier frequency band (radio frequency (RF) band). The transmission radio unit **106** then amplifies

the radar transmission signals to a predetermined transmission power through a transmission amplifier and outputs the amplified radar transmission signals to the transmission antenna **107**. The transmission antenna **107** radiates the radar transmission signals outputted from the transmission radio unit **106** into space.

To local oscillators included in the transmission radio unit **106** and a later-described reception radio unit **202**, the common reference signal is added. The local oscillators of the transmission radio unit **106** and reception radio unit **202** are thereby synchronized.

The radar transmitter **100** may include a radar transmission signal generator **101a** (illustrated in FIG. 3) instead of the radar transmission signal generator **101**. The radar transmission signal generator **101a** does not include the phase rotation controller **103**, the transmission phase rotator **104**, and the modulator **105** illustrated in FIG. 1 but includes a code storage **111** and a DA converter **112** instead. The code storage **111** previously stores a code sequence generated in the code generator **102** (FIG. 1) and sequentially and cyclically reads the stored code sequence. The DA converter **112** converts the code sequence (digital signal) outputted from the code storage **111**, to an analogue signal.

[Configuration of Radar Receiver **200**]

In FIG. 1, the radar receiver **200** includes a reception antenna **201**, the reception radio unit **202**, and a signal processor **203**.

The reception antenna **201** receives a signal (a reflection wave signal) which is a reflection of a RF radar transmission signal transmitted from the radar transmitter **100** on a reflective object including a measurement target. The reception antenna **201** outputs the received reflection wave signal to the reception radio unit **202** as a reception signal.

The reception radio unit **202** amplifies the reception signal outputted from the reception antenna **201** to a predetermined level and performs frequency conversion for the high-frequency reception signal into a baseband reception signal. The **202** converts the baseband reception signal to a baseband reception signal including an I signal (an In-phase signal component) and a Q signal (a quadrature signal component).

The signal processor **203** includes an AD converter **204**, a correlation calculator **205**, an reception phase rotator **206**, a coherent integrator **207**, and a Doppler analyzer **208**.

Each component of the signal processor **203** operates based on the reception reference clocks of a frequency which is a predetermined multiple of the frequency of the reference signal (not illustrated). The reception reference clock frequency is indicated by f_{RxBB} below. Herein, each radar transmission cycle (T_r) is an integer N_v times a discrete time interval ($1/f_{RxBB}$) which is determined by the reception reference clock frequency f_{RxBB} as the predetermined multiple of the reference signal frequency ($T_r = N_v \times (1/f_{RxBB})$). In the followings, the transmission reference clock frequency f_{Tab} has a relationship of $f_{Tab} = f_{RxBB} \times N_{TR}$ (an integer N_{TR} times the reception reference clock frequency f_{RxBB}).

The AD converter **204** samples the baseband signal including the I signal and Q signal outputted from the reception radio unit **202** at discrete times ($1/f_{RxBB}$) based on the reception reference clock frequency f_{RxBB} for conversion of the I signal and Q signal to digital data.

In the following description, the baseband reception signal including the I and Q signals at a discrete time k is represented as complex signal $x(k) = I_r(k) + jQ_r(k)$. In the following description, the discrete time k is set to 1 at the time when the m -th radar transmission cycle (T_r) starts ($k=1$). The signal processor **203** cyclically performs mea-

surement until the radar transmission cycle T_r ends. In this case, $k=1, \dots, N_v$. Herein, j is the imaginary number.

The output signal from the AD converter **204** in the m -th radar transmission cycle is represented by the following expression (23). Hereinafter $X(k)$ is called a complex baseband signal.

$$X(N_v(m-1)+k) = I_r(N_v(m-1)+k) + jQ_r(N_v(m-1)+k) \quad (23)$$

The correlation calculator **205** calculates the correlation between the complex baseband signal $X(N_v(m-1)+k)$ outputted from the AD converter **204** and the transmission code $C_n(m)$ transmitted by the radar transmitter **100** every radar transmission cycle T_r . Herein, $n=1, \dots, L$. For example, the correlation value $AC(k, m)$ of sliding correlation operation at the discrete time k in the m -th radar transmission cycle is calculated based on the following expression (24).

$$AC(k, m) = \sum_{n=1}^L X(N_v(m-1) + N_o(n-1)/N_{TR} + k) C_n(m)^* \quad (24)$$

In the expression (24), asterisk (*) indicates the complex conjugate operator. Herein, $k=1, \dots, N_v$.

The measurement range (the range of k) of the correlation operation performed by the correlation calculator **205** is not only $k=1, \dots, N_v$ but also may be limited in accordance with the range where the target as an object to be measured by the radar apparatus **10** can exist. This can reduce the processing amount by the correlation calculator **205** in the radar apparatus **10**. For example, the correlation calculator **205** may limit the measurement range to $k = N_w/N_{TR} + 1, \dots, (N_u - N_w)/N_{TR}$. In this case, the radar apparatus **10** does not perform measurement in a time slot corresponding to the code transmission slot T_w .

The process by the correlation calculator **205** is therefore not performed during the period when the radar transmission signal can directly enter the radar receiver **200**. Even if radar transmission signals directly enter the radar receiver **200**, therefore, the radar apparatus **10** is able to perform measurement without being influenced by the directly received radar transmission signals. In the case of limiting the measurement range (the range of k), the limited measurement range (the range of k) is also applied to the processes in the reception phase rotator **206**, coherent integrator **207**, and Doppler analyzer **208**. This can reduce the processing amount of each constituent components, thus reducing the power consumption in the radar receiver **200**.

The reception phase rotator **206** assigns a phase rotation $PC(m) \exp[-j\{(m-1) \bmod N_e\} \phi]$ in the direction opposite to (that cancels) a phase rotation assigned by the transmission phase rotator **104** of the radar transmitter **100** to a signal (correlation operation value) outputted from a correlation calculator **205** in each of radar transmission cycles (T_r). More specifically, as shown in the following expression (25), the reception phase rotator **206** outputs a signal $ACP(k, m)$ of an output $AC(k, m)$ of the correlation calculator **205** assigned with a phase rotation, in an m -th radar transmission cycle (T_r).

$$ACP(k, m) = PC(m) \exp[-j\{(m-1) \bmod N_e\} \phi] AC(k, m) \quad (25)$$

More specifically, the reception phase rotator **206** assigns a phase rotation in the direction opposite to a phase rotation of the transmission phase rotator **104** to the output $AC(k, m)$ (reflection wave signal) of the correlation calculator **205** in accordance with the phase change pattern ($PC(m)$).

For example, when $N_e=4$, $N_s=1$, and $PC(m)=1$, the phase shift amount $-\phi$ in each of radar transmission cycles (T_r) is

15

$-\pi/2$. In this case, phase rotation amounts outputted in the respective 4 ($=N_e$) radar transmission cycles (T_r) are, for example, 0, $-\pi/2$, $-\pi$, and $-3\pi/2$. When $N_e=4$, $N_s=-1$, and $PC(m)=-1$, the phase shift amount $-\phi$ in each of radar transmission cycles (T_r) is $-\pi/2$. However, when $PC(m)=-1$, from the relation of $\exp(j\pi)=-1$, phase rotation amounts outputted in the respective 4 ($=N_e$) radar transmission cycles (T_r) are, for example, π , $\pi/2$, 0, and $-\pi/2$. In other words, the difference between each pair of the phase rotation amounts $-\phi$ (here, $\{0, -\pi/2, -\pi, -3\pi/2\}$ and $\{\pi, \pi/2, 0, -\pi/2\}$ in different phase change patterns ($PC(m)=1, -1$) is π .

When a complementary code is used as the transmission code, a pair of codes constituting the complementary code has the same phase. Thus, as shown in the following expression (26), the reception phase rotator **206** outputs the signal $ACP(k, m)$ obtained by assigning a phase rotation to the output $AC(k, m)$ of the correlation calculator **205** such that the phase shift within the transmission cycle of two codes constituting the complementary code becomes zero.

$$ACP(k, m) = PC(m) \exp[-j\{\text{floor}((m-1)/2) - 1\} \text{mod } N_e \phi] AC(k, m) \quad (26)$$

For example, when $N_e=8$, $N_s=1$, and $PC(m)=1$, the phase shift amount $-\phi$ is $-\pi/2$. Phase rotation amounts outputted in the respective 8 ($=N_e$) radar transmission cycles (T_r) are, for example, 0, 0, $-\pi/2$, $-\pi/2$, $-\pi$, $-\pi$, $-3\pi/2$, and $-3\pi/2$. When $N_e=8$, $N_s=1$, and $PC(m)=-1$, the phase shift amount $-\phi$ is $-\pi/2$. However, when $PC(m)=-1$, from the relation of $\exp(j\pi)=-1$, phase rotation amounts outputted in the respective 8 ($=N_e$) radar transmission cycles (T_r) are, for example, π , $\pi/2$, $\pi/2$, 0, 0, $-\pi/2$, and $-\pi/2$.

Using the correlation value $ACP(k, m)$ outputted from the reception phase rotator **206** at each discrete time k in the m -th radar transmission cycle (T_r), the coherent integrator **207** adds the correlation value $ACP(k, m)$ at each discrete time k (coherent integration) in a predetermined number N_e of radar transmission cycles, thereby calculating a coherent integral value $ACC(k, v)$ at each discrete time k . Herein, $k=1, \dots, N_e$.

Specifically, the v -th coherent integral value $ACC(k, v)$ is calculated by the following expression (27).

$$ACC(k, v) = \sum_{m=1}^{N_e} ACP(k, N_e(v-1) + m) \quad (27)$$

Here, when the period of the radar transmission cycles in which the coherent integrator **207** adds the correlation operation value $ACP(k, v)$ at discrete times k (or an integration period of the coherent integrator **207**) is set to a predetermined number N_e , the reception DC offset component may be canceled by a principle described below even when the reception DC offset is included in the correlation operation value $ACP(k, v)$, and thereby noise components may be suppressed, and deterioration of radar detection performance by the reception DC offset may be inhibited.

More specifically, when the reception DC offset component α_{Rx} and the transmission DC offset component $\alpha_{Tx} \exp(j2\pi f_{dTx} \times T_r)$ including the Doppler frequency fluctuation f_{dTx} are included, the output $AC(k, m)$ of the correlation calculator **205** includes components shown in the following expression (28) irrespective of k and m .

$$\{\alpha_{Tx} \exp(j2\pi f_{dTx} T_r) + \alpha_{Rx}\} \sum_{n=1}^L C_n(m)^* \quad (28)$$

16

The output $ACP(k, m)$ of the reception phase rotator **206** includes components shown in the following expression (29) irrespective of k .

$$PC(m) \exp[-j\{(m-1) \text{mod } N_e\} \phi] \left[\{\alpha_{Tx} \exp(j2\pi f_{dTx} T_r) + \alpha_{Rx}\} \sum_{n=1}^L C_n(m)^* \right] \quad (29)$$

Therefore, the output $ACC(k, v)$ of the coherent integrator **207** includes components shown in the following expression (30) irrespective of k .

$$\sum_{m=1}^{N_e} PC(N_e(v-1) + m) \exp[-j\{(m-1) \text{mod } N_e\} \phi] \quad (30)$$

$$\left[\{\alpha_{Tx} \exp(j2\pi(N_e(v-1) + m - 1) f_{dTx} T_r) + \alpha_{Rx}\} \right.$$

$$\left. \sum_{n=1}^L C_n(N_e(v-1) + m)^* \right] =$$

$$PC(N_e(v-1) + m) \sum_{m=1}^{N_e} \exp[-j\{(m-1) \text{mod } N_e\} \phi]$$

$$\left[\{\alpha_{Tx} \exp(j2\pi(N_e(v-1) + m - 1) f_{dTx} T_r) + \alpha_{Rx}\} \right.$$

$$\left. \sum_{n=1}^L C_n(N_e(v-1) + m)^* \right]$$

As shown in the expression (30), in the integration period of the coherent integrator **207**, if the following expression (31) is constant, the following expression (32) is satisfied.

$$\sum_{n=1}^L C_n(m)^* \quad (31)$$

$$\sum_{m=1}^{N_e} \exp[-j\{(m-1) \text{mod } N_e\} \phi] = 0 \quad (32)$$

Thus, the reception DC offset component (component including α_{Rx}) shown in the expression (30) is canceled. In the expression (30), when the Doppler frequency fluctuation f_{dTx} is zero, the transmission DC offset component (component including α_{Tx}) is canceled in the same manner as the reception DC offset component.

On the other hand, when the Doppler frequency fluctuation f_{dTx} is not zero or when the reflection wave signal includes the Doppler frequency fluctuation, the output $ACC(k, v)$ of the coherent integrator **207** includes the transmission DC offset component shown in the following expression (33) irrespective of k .

$$PC(N_e(v-1) + m) \sum_{m=1}^{N_e} \exp[-j\{(m-1) \text{mod } N_e\} \phi] \quad (33)$$

$$\left[\{\alpha_{Tx} \exp(j2\pi(N_e(v-1) + m - 1) f_{dTx} T_r)\} \sum_{n=1}^L C_n(N_e(v-1) + m)^* \right]$$

The phase rotation controller **103** performs control to randomly change the phase change pattern $PC(N_e(v-1) + m)$

of the phase rotation to 1 or -1 for every predetermined number N_e of times (or every integration period of the coherent integrator **207**). Thus, in the output of the Doppler analyzer **208**, a residual transmission DC offset component included in the output ACC(k, v) of the coherent integrator shown in the expression (33) is whitened in the Doppler frequency region. Thus, increase of noise level (floor level) of a specific Doppler frequency component may be inhibited, and deterioration of radar detection function may be suppressed.

The Doppler analyzer **208** performs a Doppler frequency analysis for the output signal from the coherent integrator **207**. Specifically, the Doppler analyzer **208** performs the Doppler frequency analysis on a basis of the N_d outputs ACC(k, 1) to ACC(k, N_d) of the coherent integrator **207** as a unit, which are obtained at each discrete time k, with the discrete time k in synchronization. As described above, the residual transmission DC offset component included in each of N_d outputs ACC(k, 1) to ACC(k, N_d) of the coherent integrator **207** is whitened in the Doppler frequency region. Thus, Doppler frequency analysis by the Doppler analyzer **208** may suppress increase in the noise level (floor level) of a specific frequency component caused by the transmission DC offset component.

More specifically, as shown in the following expression (34), the Doppler analyzer **208** performs coherent integration after correcting phase variations $\Psi(f_s)=2\pi f_s(T_r \times N_e)\Delta\Psi$ in accordance with $2N_f$ different Doppler frequencies $f_s\Delta\Psi$.

$$FT_CI(k, f_s) = \sum_{q=0}^{N_d-1} ACC(k, q+1)\exp[-j\psi(f_s)q] = \sum_{q=0}^{N_d-1} ACC(k, q+1)\exp[-j2\pi f_s T_r N_e q \Delta\phi] \quad (34)$$

Herein, FT_CI(k, f_s) indicates a result of coherent integration of Doppler frequencies $f_s\Delta\Psi$ at the discrete time k by the Doppler analyzer **208**. Herein, $f_s=-N_f+1, \dots, 0, \dots, N_f$ and $k=1, \dots, (N_r+N_u)N_s/N_o$. $\Delta\Psi$ is a unit of phase rotation.

The signal processor **203** thereby obtains the results of coherent integration corresponding to the $2N_f$ Doppler frequency components at each discrete time k, FT_CI(k, $-N_f$), \dots , FT_CI(k, N_f-1), for each period corresponding to plural numbers $N_e \times N_d$ of the radar transmission cycles T_r ($T_r \times N_e \times N_d = T_r \times Q$). Herein, j is the imaginary unit.

When $\Delta\Psi=1/N_d$, the processing of the Doppler analyzer **208** is equivalent to discrete Fourier transform (DFT) for the outputs of the coherent integrator **207** with a sampling interval of $T_r \times N_e$, or a sampling frequency of $1/(T_r \times N_e)$.

Moreover, when N_f is set to a power of 2, fast Fourier transform (FFT) can be applied in the Doppler analyzer **208**, thus reducing the processing amount. When $N_f > N_d$, FFT can be applied in a similar manner by performing zero padding in the region of $q > N_d$ as $ACC(k, N_d(w-1)+q+1)=0$, reducing the processing amount.

Based on the outputs FT_CI(k, f_s) of the Doppler analyzer **208**, the radar apparatus **10** estimates the range/Doppler frequency (relative velocity) of the radar measurement target.

The square $|FT_CI(k, f_s)|^2$ of the absolute value of the output FT_CI(k, f_s) from the Doppler analyzer **208** corresponds to the reception level of reflection waves from the target at each Doppler frequency f_s and each discrete time k. The radar apparatus **10** estimates the range R(k) to the target

based on the discrete time k and Doppler frequency f at which the power increases from the noise level to a predetermined peak level or higher and estimates the relative velocity $v_d(f_s)$ based on the Doppler frequency in the following manner. Herein, $f_s=-N_f+1, \dots, 0, \dots, N_f$ and $k=1, \dots, (N_r+N_u)N_s/N_o$.

To translate the time information k to the range information R(k), the following expression (35) is used. Herein, T_w is the code transmission slot; L is the pulse code length; and C_0 is the velocity of light.

$$R(k) = k \frac{T_w C_0}{2L} \quad (35)$$

To translate the Doppler frequency information f_s to the relative velocity component $V_d(f_s)$, the following expression (36) is used. Herein, λ is the wavelength of the carrier frequency of the RF radar transmission signal outputted from the transmission radio unit **106**.

$$v_d(f_s) = \frac{\lambda}{2} f_s \Delta\psi \quad (36)$$

The effects of the operations of the phase rotation controller **103**, the transmission phase rotator **104**, and the reception phase rotator **206** described above are confirmed using computer simulations. The results thereof are shown below.

FIGS. **4A** and **4B** illustrate outputs (reception levels) from the Doppler analyzer **208** under the conditions where one measurement target moves away from the radar apparatus **10** at a distance of 5 m and a velocity of 20 km/h.

In FIGS. **4A** and **4B**, the transmission DC offset component (the carrier leak component) exists in the transmission radio unit **106** as the condition FIGS. **4A** and **4B** illustrate the results of computer simulations performed under the following conditions: the radar transmission codes are Spano codes (code length $L=64$); the number N_e of additions by the coherent integrator **207** is 32; and the number N_d of samples in the Doppler analyzer **208** is 512.

FIG. **4A** illustrates a result when the phase inversion (PC(m)) is not randomly changed over as in a conventional radar apparatus, but unlike operations of the radar apparatus **10** according to the present embodiment. On the other hand, FIG. **4B** illustrates a result of random change-over of the phase inversion by the phase change pattern PC(m) in the phase rotation controller **103** as described above.

In both FIGS. **4A** and **4B**, a sharp peak appears at coordinates of a distance of 5 meters and a speed per hour of 20 km/h. This indicates that a desired measurement target is detected.

However, in FIG. **4A**, peaks of the weak reception level appear evenly across entire distance range (0 to 200 meters) in the Doppler frequency component of the speed per hour of 20 km/h in addition to the peak of the desired measurement target at coordinates of the distance of 5 meters and the speed per hour of 20 km/h. These peaks of the weak reception level are frequency components that do not exist intrinsically, and cause error detection.

Meanwhile, in FIG. **4B** illustrating a result based on operations according to the embodiment, peaks of the weak reception level such as detected in FIG. **4A** do not appear evenly across entire distance range in a specific Doppler frequency component, in addition to the peak of a desired

measurement target at the distance of 5 meters and the speed per hour of 20 km/h. In other words, according to the embodiment, no deterioration of radar performance causing an error detection may be verified even under the condition that the transmission DC offset (carrier leak) exists in the transmission radio unit **106**.

As described above, the radar apparatus **10** includes a phase rotation controller **103** which changes the phase change pattern $PC(m)$ of the phase rotation amount every period ($N_e \times T_r$) corresponding to a plurality (N_e) of radar transmission cycles (T_r), the phase change pattern $PC(m)$ being to be applied to a radar transmission signal (transmission code) within the period ($N_e \times T_r$), a transmission phase rotator **104** which assigns a phase rotation (first phase rotation) to the radar transmission signal in accordance with the phase change pattern, and a reception phase rotator **206** configured to assign a phase rotation in the direction opposite to the first phase rotation to a reflection wave signal (in FIG. 1, correlation operation value $ACC(k, m)$) in accordance with the phase change pattern.

More specifically, with operations of the phase rotation controller **103**, the transmission phase rotator **104**, and the reception phase rotator **206**, the radar apparatus **10** randomly switches whether not to set each unit of transmission codes to a code added with a phase inversion (code added with a phase change of π), where one unit of transmission codes are those that cancel the reception DC offset within the period ($N_e \times T_r$).

Thus, in the coherent integrator **207** of the radar apparatus **10**, the output subjected to the coherent integration processing does not have a fixed phase fluctuation, and thereby the residual transmission DC offset component is whitened in the Doppler frequency region. Thus, increase of noise level (floor level) of a specific Doppler frequency component at the output of the Doppler analyzer **208** may be inhibited, and deterioration of radar detection function may be suppressed.

Thus, according to the embodiment, deterioration of radar detection performance caused by a circuit error may be suppressed.

According to the embodiment, the radar apparatus **10** may inhibit deterioration of radar detection performance caused by a transmission DC offset without a circuit configuration for correcting the transmission DC offset (carrier leak) with high accuracy. Thus, configuration of the radar apparatus **10** may be simplified.

In FIG. 1, the reception phase rotator **206** of the radar apparatus **10** is provided after the correlation calculator **205**. As illustrated in FIG. 5, the reception phase rotator **206** may be provided before the correlation calculator **205**. This configuration provides the same effects as that of Embodiment 1.

Embodiment 2

Since a radar apparatus according to the Embodiment 2 has a basic configuration common to the radar apparatus **10** according to the Embodiment 1, description is given with reference to FIG. 1.

As illustrated in FIG. 6, a configuration including two or more radar apparatuses (FIG. 1) according to the Embodiment 1 is described in the Embodiment 2. Hereinafter, a configuration including two radar apparatuses A and B illustrated in FIG. 6 is described as an example.

In the Embodiment 2, a plurality of radar apparatuses **10** differentiate, from each other, the phase change pattern controlled by the phase rotation controller **104** of each radar apparatus **10**. For example, a phase change pattern $PP^{(1)}(q)$

(however, $q=1, 2, \dots, N_{pp}$) is set to the radar apparatus A illustrated in FIG. 6, and a phase change pattern $PP^{(2)}(q)$ (however, $q=1, 2, \dots, N_{pp}$) is set to the radar apparatus B.

As an example, the phase rotation controller **103** of each radar apparatus **10** may set a different phase change pattern by shifting the transmission timing of the same M-sequence code. For example, the phase change pattern $PP^{(1)}(q)$ of the radar apparatus A is a pattern using a M-sequence code of a code length of 511 (however, $q=1, \dots, 511$). In this case, the phase change pattern $PP^{(2)}(q)$ of the radar apparatus B may be a pattern with the transmission timing shifted by N_{shift} of the M-sequence code used in the radar apparatus A. More specifically, $PP^{(2)}(q)=PP^{(1)}(q+N_{shift})$.

For example, FIG. 6 shows an example where a radar receiver **200** of the radar apparatus A receives a reception signal (desired signal) that is a reflected wave of the radar transmission signal transmitted by the radar apparatus A, and a reflected wave (interference signal) of the radar transmission signal transmitted by the radar apparatus B.

In this case, transmission DC offset components residing in the reception signals from radar apparatuses A and B are whitened in the Doppler frequency region in the same manner as in the Embodiment 1 by differentiating phase change patterns between radar apparatuses A and B, as described above. Thus, increase of the noise level (floor level) of a specific Doppler frequency component may be inhibited, and deterioration of radar detection function of the radar apparatus A may be suppressed. In other words, this provides an effect of reducing mutual interference between a plurality of radar apparatuses **10** using the same frequency band or some of frequency bands overlapping each other.

FIG. 7 illustrates a result of evaluations by a computer simulation on the mutual interference amount when radar apparatuses A and B transmit radar transmission signals using phase change patterns different from each other.

In FIG. 7, radar apparatuses A and B use complementary codes as transmission codes, and phase shifts in the phase rotation controller **103** are $N_e=16$ and $N_s=2$. $N_d=512$ is used in the Doppler analyzer **208** in the radar apparatuses A and B.

In FIG. 7, the horizontal axis shows the time shift amount in the transmission timing of the phase change pattern by a unit of the radar transmission cycle (T_r), and the vertical axis shows reception power (desired power) of the radar apparatus A, reception power (undesired power (plotted with x)) of the radar apparatus B, and the signal to interference power ratio (SIR (plotted with white circle)) of the radar apparatus A.

From the simulation result shown in FIG. 7, improvement of the SIR of the radar apparatus A by about 20 dB may be verified when there is a time shift of the transmission timing by more than 16 ($=N_e$) radar transmission cycles in the transmission timing of the M-sequence code as a phase change pattern of the radar apparatuses A and B.

The phase rotation controller **103** sequentially reads elements $PP(q)$ of the phase change pattern and repeatedly outputs a value of the same element across N_e radar transmission cycles ($=N_e \times T_r$). This indicates that when $N_{shift} \leq 1$, there are time shifts of the transmission timing more than 16 ($=N_e$) radar transmission cycles between different phase change patterns, and thereby interference suppression effect may be enhanced. Improvement amount of the SIR depends on the code length N_{pp} of the code used in the phase change pattern, and the pattern N_d (for example, $N_d=512$) used by the Doppler analyzer **208**. For this reason, as longer N_p and N_d are used in an allowable measurement time, the SIR is improved more.

As described above, in the Embodiment 2, the phase change pattern is different between two or more radar apparatuses **10**. For example, the transmission timing of the same M-sequence code used in the phase change patterns of the radar apparatuses **10** is shifted. This reduces mutual interference between the plurality of radar apparatuses **10**.

In the above case, transmission timings of the plurality of radar apparatuses **10** may match each other incidentally. Thus, there is a possibility stochastically that interference may not be suppressed. Meanwhile, mutual interference may be reduced stochastically by a method described below.

Specifically, in a plurality of radar apparatuses **10**, a preferred pair of low mutual correlation out of M-sequence codes of a code length of N_{pp} are used in each phase change pattern.

Alternatively, it is known that N_{PP} pieces of different gold codes may be generated from a preferred pair of low mutual correlation out of M-sequence codes of a code length of N_{PP} . Thus, in a plurality of radar apparatuses **10**, gold codes generated from a preferred pair of low mutual correlation may be used in each phase change pattern.

Alternatively, mutual interference may be reduced stochastically by randomly varying each phase change pattern every radar measurement or every predetermined number of radar measurements in a plurality of radar apparatuses **10**.

Embodiment 3

In the Embodiment 2, a method of reducing mutual interference between a plurality of radar apparatuses **10** by differentiating the phase change pattern between the plurality of radar apparatuses **10** is described. Meanwhile, in the Embodiment 3, a configuration of a multiple input multiple output (MIMO) radar using a plurality of transmission and reception antennas in place of a plurality of radar apparatuses **10** is described.

In other words, in the Embodiment 3, the phase change pattern is different between a plurality of transmission antennas (or between streams of the MIMO).

FIG. **8** is a block diagram illustrating a configuration example of a radar apparatus **20** according to Embodiment 3. In FIG. **8**, the same components as those of Embodiment 1 (FIG. **1**) are given the same reference numerals, and the description thereof is omitted.

The radar apparatus **20** illustrated in FIG. **8** has a time-division MIMO radar configuration which transmits time-division multiplexed different radar transmission signals switching to one of the plural transmission antennas in a time-division manner and separates each radar transmission signal for reception processing. The configuration of the radar apparatus is not limited thereto. The radar apparatus **20** may be configured to transmit different frequency-division multiplexed or code-division multiplexed transmission signals through plural transmission antennas and separates each transmission signal for reception processing.

[Configuration of Radar Transmitter **300**]

A radar transmitter **300** of the radar apparatus **20** includes the radar transmission signal generators **101-1** to **101-Nt**, a switching controller **301**, a transmission switch **302**, and a transmitting array antenna unit **303**.

The transmitting array antenna unit **303** includes Nt transmitting antennas (Tx#1 to Tx#Nt).

Radar transmission signal generators **101-1** to **101-Nt** are provided in Nt transmission antennas (Tx#1 to Tx#Nt) so as to correspond respectively. Each radar transmission signal generator **101** operates in the same manner as in the Embodi-

ment 1 (FIG. **1**). However, the phase change pattern set in each radar transmission signal generator **101** is different from each other.

For example, the phase change pattern in each of Nt radar transmission signal generators **101** is set by shifting the transmission timing of the same M-sequence code by more than one code elements.

Specifically, the phase change pattern in the radar transmission signal generator **101-1** is $PP^{(1)}(q)$ (however, $q=1, N_{PP}$). In this case, the phase change pattern in the radar transmission signal generator **101-2** may be $PP^{(2)}(q+N_{shift})$, and the phase change pattern in the radar transmission signal generator **101-3** may be $PP^{(3)}(q+2N_{shift})$. In the same manner, the phase change pattern in a radar transmission signal generator **101-Nt** may be $PP^{(Nt)}(q+(Nt-1)N_{shift})$. However, $N_{shift} \geq 1$.

A preferred pair of low mutual correlation out of M-sequence codes of a code length of N_{pp} may be used as a phase change pattern in each of the Nt radar transmission signal generators **101**. Alternatively, it is known that N_{pp} different gold codes may be generated from a preferred pair of low mutual correlation out of M-sequence codes of a code length of N_{pp} . Thus, gold codes generated from a preferred pair of low mutual correlation may be used as a phase change pattern in each of Nt radar transmission signal generators **101**. Alternatively, mutual interference may be reduced stochastically by randomly varying the phase change pattern in each of Nt units of radar transmission signal generators **101** every radar measurement (or for every predetermined number of measurements).

The switching controller **301** outputs a control signal (hereinafter, referred to as a switching control signal) indicating a time to change the transmitting antennas (Tx#1 to Tx#Nt) of the transmitting array antenna unit **303** (or instructing selection of the output of the radar transmission signal) to the transmission switch **302** and a radar receiver **400** (the correlation calculator **205** and an output switch **403**).

The transmission switch **302** selects one of the Nt transmitting antennas of the transmitting array antenna unit **303** based on the switching control signal from the switching controller **301** to input the output signal from the radar transmission signal generator **101** corresponding to the selected transmitting antenna among the output signal from the Nt radar transmission signal generator **101**, to the selected transmitting antenna. The transmission switch **302** applies frequency conversion to the output signal (baseband radar transmission signal) from the selected radar transmission signal generator **101**, into a predetermined radio frequency and outputs the radio frequency signal to the selected (connected) transmitting antenna.

The transmitting array antenna unit **303** radiates the radar transmission signal outputted from the transmission switch **302** from the transmitting antenna selected by (connected to) the transmission switch **302** into space.

Hereinafter, a description is given of an operation of the switching controller **301** to control the transmission switch **302**. The operation of the switching controller **301** to control the radar receiver **400** is described later in the description of the operation of the radar receiver **400**.

The switching controller **301** outputs to the transmission switch **302**, the switching control signal to sequentially switch to one of the transmitting antennas and radar transmission signal generator **101** every N_e radar transmission cycles.

For example, the switching controller **301** causes the transmission switch **302** to input the output signal from the

radar transmission signal generator **101-1** and the transmitting antenna (Tx#1) of the transmitting array antenna unit **303** to output the converted high-frequency signal in the first N_e radar transmission cycles ($N_e \times T_r$).

The switching controller **301** causes the transmission switch **302** to input the output signal from the radar transmission signal generator **101-2** and the transmitting antenna (Tx#2) of the transmitting array antenna unit **303** to output the converted high-frequency signal in the next N_e radar transmission cycles ($N_e \times T_r$).

The switching controller **301** repeats the same operation and causes the transmission switch **302** to input the output signal from the radar transmission signal generator **101-Nt** and the transmitting antenna (Tx#Nt) of the transmitting array antenna unit **303** to output the converted high-frequency signal.

The switching controller **301** again causes the transmission switch **302** to input the output signal from the radar transmission signal generator **101-1** and the transmitting antenna (Tx#1) of the transmitting array antenna unit **303** to output the converted high-frequency signal in the next N_e radar transmission cycles ($N_e \times T_r$).

The switching controller **301** repeats the aforementioned operation for a predetermined number of times ($N_d \times N_r$).

In the above operations, the radar transmitter **300** operates so as to sequentially read GP(m) (for example, see the expression (19) or (20)) described in the Embodiment 1 as a signal generated by each radar transmission signal generator **101**. Here, $m=1, \dots, N_e \times N_d$.

[Configuration of Radar Receiver **400**]

The radar receiver **400** of the radar apparatus **20** includes a receiving array antenna unit **401**, an antenna system processor **402**, and a direction estimator **404**.

The receiving array antenna unit **401** includes N_a receiving antennas (Rx#1 to Rx# N_a). The N_a receiving antennas individually receive signals (reflection wave signals) which are reflections of the radar transmission signal transmitted from the radar transmitter **300** on reflective objects including a radar measurement target. The signals received by the N_a receiving antennas are inputted to the respective antenna system processors **402** corresponding to the receiving antennas (Rx#1 to Rx# N_a) as reception signals.

Each of the antenna system processors **402** includes the reception radio unit **202** and the signal processor **203**.

The reception radio unit **202** of the z -th antenna system processor **402-z** amplifies the reception signal from the z -th receiving antenna (Rx# z) to a predetermined level and performs frequency-conversion for the high-frequency reception signal into a baseband reception signal. The z -th reception radio unit **202** then converts the baseband reception signal to the baseband reception signal including I and Q signals. Herein, $z=1, \dots, N_a$.

The signal processor **203** of the z -th antenna system processor **402-z** includes the AD converter **204**, the correlation calculator **205**, the reception phase rotator **206**, an output switch **403**, the coherent integrators **207**, and the Doppler analyzers **208**. The signal processor **203** includes N_t coherent integrators **207** and N_t Doppler analyzers **208** corresponding to the transmitting antennas (Tx#1 to Tx# N_t).

Hereinafter, a description is given of each component of the signal processor **203** of the z -th antenna system processor **402-z**, mainly operations different from those of Embodiment 1.

The correlation calculator **205** calculates correlation between the complex baseband signals $X(N_v(m-1)+k)$ outputted from the AD converter **204** (see the expression (23), for example) and the transmission codes generated by the

radar transmission signal generator **101** every N_e radar transmission cycles ($N_e \times T_r$) selected by the switching controller **301**.

The reception phase rotator **206** assigns, to a signal (correlation operation value) outputted from the correlation calculator **205**, a phase rotation in the direction opposite to (in a canceling direction) a phase rotation assigned by the transmission phase rotator **103** of the radar transmission signal generator **101** selected by the switching controller **301** every N_e radar transmission cycles ($N_e \times T_r$).

The output switch **403** switches to one of the coherent integrators **207-1** to **207-Nt** corresponding to the transmission antenna number (#1 to # N_t) selected every N_e radar transmission cycles ($N_e \times T_r$) by the switching controller **301**.

When the transmitting antenna (Tx#1) is selected by the switching controller **301**, for example, the output switch **403** outputs the signal from the reception phase rotator **206** to the coherent integrator **207-1** corresponding to the transmitting antenna (Tx#1).

When the transmitting antenna (Tx#2) is selected by the switching controller **301**, the output switch **403** outputs the signal from the reception phase rotator **206** to the coherent integrator **207-2** corresponding to the transmitting antenna (Tx#2).

The output switch **403** repeats the same operation and, when the transmitting antenna (Tx# N_t) is selected by the switching controller **301**, outputs the signal from the reception phase rotator **206** to the coherent integrator **207-Nt** corresponding to the transmitting antenna (Tx# N_t).

For unit period defined by a plurality (N_e) of radar transmission cycles ($=N_e \times T_r$), the N_D -th coherent integrator **207- N_D** performs coherent integration for the outputs of the reception phase rotator **206** selected by the switching controller **301** every N_e radar transmission cycle ($N_e \times T_r$). Herein, $N_D=1, \dots, N_t$.

Each of the Doppler analyzers **208** performs a Doppler frequency analysis for the output signals from the corresponding coherent integrator **207**. The Doppler analyzer **208** performs a Doppler frequency analysis using the N_d outputs from the coherent integrator **207** obtained at each discrete time k , with of the discrete time k in synchronization.

As described above, in the radar apparatus **20**, transmission antennas are changed over by the switching controller **301** every predetermined number N_e of times (or, an integration period of the coherent integrator **207**), and a phase change pattern PC(m) different between transmission antennas is set. Thus, in the output of the Doppler analyzer **208** corresponding to respective transmission antennas, a residual transmission DC offset component included in the output ACC(k, v) (see the expression (31)) of the coherent integrator **207** to the radar transmission signal transmitted from respective transmission antennas is whitened in the Doppler frequency region in the same manner as the Embodiment 1. Thus, increase of the noise level (floor level) of a specific Doppler frequency component may be inhibited, and deterioration of radar detection function may be suppressed. Further, since phase change patterns different between transmission antennas are set, mutual interference between radar transmission signals transmitted by respective transmission antennas may be reduced.

In the following description, w -th outputs $FT_Cl_{(z)}^{(1)}(k, fs, w), \dots, FT_Cl_{(z)}^{(N_d)}(k, fs, w)$ from the Doppler analyzers **208** at each discrete time k , which are obtained by the same processing in the antenna system processors **402-1** to **402- N_a** , are collectively represented as a virtual reception array correlation vector $h(k, fs, w)$ shown in the following expressions (37) and (38). The virtual reception array correlation

vector $h(k, fs, w)$ includes $N_t \times N_a$ (a product of the number N_t of transmitting antennas and the number N_a of receiving antennas) elements. The virtual reception array correlation vector $h(k, fs, w)$ is used to describe the process to perform direction estimation based on phase differences in reflection wave signals from the target between the receiving antennas. Herein, $z=1, \dots, N_t$, and $N_D=1, \dots, N_a$. $f_s=-N_f+1, \dots, 0, \dots, N_f$.

$$h(k, fs, w) = \begin{bmatrix} FT_CI_1^{(1)}(k, fs, w) \\ FT_CI_2^{(1)}(k, fs, w) \\ \vdots \\ FT_CI_{N_a}^{(1)}(k, fs, w) \\ FT_CI_1^{(2)}(k, fs, w) \\ FT_CI_2^{(2)}(k, fs, w) \\ \vdots \\ FT_CI_{N_a}^{(2)}(k, fs, w) \\ \vdots \\ FT_CI_1^{(N_D)}(k, fs, w) \\ FT_CI_2^{(N_D)}(k, fs, w) \\ \vdots \\ FT_CI_{N_a}^{(N_D)}(k, fs, w) \end{bmatrix} = \begin{bmatrix} h^1(k, fs, w) \\ h^2(k, fs, w) \\ \vdots \\ h^{N_D}(k, fs, w) \end{bmatrix} \quad (37)$$

$$h^{N_D}(k, fs, w) = \begin{bmatrix} FT_CI_1^{(N_D)}(k, fs, w) \\ FT_CI_2^{(N_D)}(k, fs, w) \\ \vdots \\ FT_CI_{N_a}^{(N_D)}(k, fs, w) \end{bmatrix} \quad (38)$$

Hereinabove, the processing in each component of the signal processor **203** of the antenna system processor **402-z** is described.

The direction estimator **404** multiplies the w -th virtual array correlation vector $h(k, fs, w)$ at each discrete time k from the Doppler analyzers **208** of the antenna system processors **402-1** to **402-Na**, by array correction values $h_cal[b]$ to correct phase and amplitude deviations between the transmitting antennas of the transmitting array antenna unit **503** and between the receiving antennas of the receiving array antenna unit **401**, to calculate a virtual receiving array correlation vector $h_{after_cal}(k, fs, w)$ with the inter-antenna deviations corrected. The virtual receiving array correlation vector $h_{after_cal}(k, fs, w)$ is represented by the following expression (39). $b=1, \dots, (N_t \times N_a)$.

$$h_{after_cal}(k, fs, w) = CAh(k, fs, w) = \begin{bmatrix} h_1(k, fs, w) \\ h_2(k, fs, w) \\ \vdots \\ h_{N_a \times N_r}(k, fs, w) \end{bmatrix} \quad (39)$$

$$CA = \begin{bmatrix} h_cal_{[1]} & 0 & \dots & 0 \\ 0 & h_cal_{[2]} & \ddots & \dots \\ \vdots & \ddots & \ddots & 0 \\ 0 & \dots & 0 & h_cal_{[N_t \times N_a]} \end{bmatrix}$$

The virtual receiving array correlation vector $h_{after_cal}(k, fs, w)$ with the inter-antenna deviations corrected is a column vector composed of $N_a \times N_r$ elements. Hereinafter, each element of the virtual receiving array correlation vector $h_{after_cal}(k, fs, w)$ is represented as $h_1(k, fs, w), \dots, h_{N_a \times N_r}(k, fs, w)$ to be used in description of the direction estimation process.

The direction estimator **404** uses the virtual receiving array correlation vector $h_{after_cal}(k, fs, w)$ to perform the

direction estimation process based on the phase difference in reflection wave signals between the receiving antennas.

The direction estimator **404** calculates a spatial profile by varying the azimuth direction θ within a predetermined angular range in a direction estimation evaluation function value $P_H(\theta, k, fs, w)$. The direction estimator **404** extracts a predetermined number of the largest local peaks in the calculated spatial profile and determines the azimuth directions of the extracted local peaks as the direction-of-arrival estimation values.

The evaluation function value $P_H(\theta, k, fs, w)$ depends on the DOA estimation algorithm. For example, the evaluation function value $P_H(\theta, k, fs, w)$ may be based on the estimation method using an array antenna disclosed in "Direction-of-arrival estimation using signal subspace modeling Cadzow, J. A.; Aerospace and Electronic Systems, IEEE Transactions on Volume: 28, Issue: 1 Publication Year: 1992, Page(s): 64-79".

For example, the beam former algorithm is represented by the following expressions (40) and (41). Other algorithms, such as Capon and MUSIC, are also applicable.

$$P_H(\theta_u, k, fs, w) = |a_H(\theta_u)^H h_{VAH}(k, fs, w)|^2 \quad (40)$$

$$a_H(\theta_u) = \begin{bmatrix} 1 \\ \exp\{-j2\pi d_H \sin\theta_u / \lambda\} \\ \vdots \\ \exp\{-j2\pi(N_{VAH} - 1)d_H \sin\theta_u / \lambda\} \end{bmatrix} \quad (41)$$

Herein, the superscript H is the Hermitian transpose operator. $a_H(\theta_u)$ indicates the direction vector of the virtual receiving array with respect to the arriving waves in the azimuth direction θ_u . θ_u is varied at a predetermined azimuth interval β_1 within the range of azimuth for the direction-of-arrival estimation. For example, θ_u is set as follows.

$$\theta_u = \theta_{min} + u\beta_1, u=0, \dots, NU$$

$$NU = \text{floor}[(\theta_{max} - \theta_{min}) / \beta_1] + 1$$

Herein, the floor(x) is a function to return the greatest integer not exceeding a real value x.

Hereinabove, the configuration of the radar receiver **400** is described.

As above, since the variable pattern to the radar transmission signal transmitted by respective transmission antennas is differentiated by the radar apparatus **20** that is the MIMO radar, mutual interference between radar transmission signals transmitted by changing over a plurality of transmission antennas may be reduced.

In the Embodiment 3, time intervals of changing over a plurality of transmission antennas may be narrowed to an extent of the reduction of mutual interference between radar transmission signals transmitted by changing over a plurality of transmission antennas, and thereby detection time may be reduced.

Hereinabove, the embodiments according to an aspect of the disclosure are described.

The operations of the aforementioned embodiments and variations thereof may be combined properly.

Other Embodiments

(1) In the above embodiments, radar apparatuses **10** and **20** may include a circuit configuration that corrects the transmission DC offset in a simplified manner. Thus, when concurrently using a configuration of controlling the phase

change pattern described above and a configuration of correcting the transmission DC offset, radar apparatuses **10** and **20** may further suppress increase of the noise level caused by the transmission DC offset.

(2) In the above embodiments, a coding pulse radar is used. However, the disclosure may be also applied to a radar scheme using a frequency-modulated pulse wave, such as a chirp and a pulse radar.

(3) In the radar apparatuses **10** and **20** illustrated in FIGS. **1**, **5**, **6**, and **8**, the radar transmitters **100** and **300** may be individually provided physically apart from the radar receivers **200** and **400** respectively.

(4) The radar apparatuses **10** and **20** may include a central processing unit (CPU), a storage medium such as a read only storage (ROM) storing control programs, and working memories such as a random access storage, which are not illustrated, for example. In this case, the function of each component is implemented by execution of a control program by the CPU.

Hereinabove, the various types of embodiments are described with reference to the drawings. However, it is obvious that the disclosure is not limited to the aforementioned examples. It is obvious that those skilled in the art can arrive at various modifications and changes within the scope of the matters described in the claims, and it is certainly understood that such changes and modifications are within the technical scope of the disclosure. Moreover, the constituent components of the aforementioned embodiments may be arbitrarily combined without departing from the scope of the disclosure.

In the above description of each embodiment, the disclosure is implemented by hardware by way of example. The disclosure can be implemented by software in cooperation with hardware.

Each functional block used in the description of the above embodiments is typically implemented as an LSI, which is an integrated circuit. The integrated circuit controls each functional block used in the description of the above embodiments and may include input and output terminals. These functional blocks may be implemented as individual chips, or all or some of the functional blocks may be implemented together as a chip. In the above description, LSIs may be replaced with ICs, system LSIs, super LSIs, or ultra-LSIs depending on the degree of integration.

The integration is not limited to the way of using LSIs and may be implemented using a dedicated circuit or a general purpose processor. Alternatively, the integration may be implemented using a field programmable gate array (FPGA) which can be programmed after manufactured as an LSI or a reconfigurable processor in which connections or settings of circuit cells of the LSI are reconfigurable.

Moreover, if another integration technique which can be replaced for LSIs appears by progresses in semiconductor techniques or other derived techniques, it is certain that the functional blocks can be integrated using the integration technique. The likely applications include biological technologies and the like.

SUMMARY OF DISCLOSURE

A radar apparatus of the disclosure is the radar apparatus including a radar transmitter which transmits a radar signal in a predetermined transmission cycle; and a radar receiver which receives a reflection wave signal being a reflection of the radar signal on a target. The radar transmitter includes a phase rotation controller which randomly varies a pattern of a phase rotation amount every period corresponding to a

plurality of transmission cycles, the pattern being to be applied to the radar signal within a period; and a transmission phase rotator which assigns a first phase rotation to the radar signal in accordance with the pattern. The radar receiver includes a reception phase rotator which assigns a second phase rotation in a direction opposite to a direction of the first phase rotation to the reflection wave signal in accordance with the pattern.

In the radar apparatus of the disclosure, a difference between phase rotation amounts in patterns different from each other is 0 or π .

In the radar apparatus of the disclosure, the pattern is based on a pseudo random code.

In the radar apparatus of the disclosure, the phase rotation controller further assigns a phase rotation such that a predetermined phase shift within the plurality of transmission cycles is an integral multiple of 2π .

In the radar apparatus of the disclosure, when a complementary code is used to generate the radar signal, the phase rotation controller assigns phase rotations such that a phase shift is not made within every two transmission cycles where a pair of codes constituting the complementary code are transmitted, but a predetermined phase shift is made between two transmission cycles.

In the radar apparatus of the disclosure, patterns are different between a plurality of radar apparatuses.

In the radar apparatus of the disclosure, the radar transmitter includes a plurality of transmission antennas, and patterns are different between the transmission antennas.

A radar method of the disclosure is the radar method including transmitting a radar signal in a predetermined transmission cycle; and receiving a reflection wave signal being a reflection of the radar signal on a target. In the method, a pattern of a phase rotation amount is randomly varied every period corresponding to a plurality of the radar transmission cycles, the pattern being to be applied to the radar signal within a period; a first phase rotation is assigned to the radar signal in accordance with the pattern; and a second phase rotation in a direction opposite to a direction of the first phase rotation is assigned to the reflection wave signal in accordance with the pattern.

The disclosure is applicable to radar apparatuses detecting a wide range of angle.

What is claimed is:

1. A radar apparatus, comprising:

a radar transmitter which, in operation, transmits radar signals in a plurality of transmission cycles; and

a radar receiver which, in operation, receives reflection wave signals, the reflection wave signals being reflections of the radar signals on a target,

wherein

the radar transmitter includes

a phase rotation controller which, in operation, assigns a unit phase rotation amount every N_e transmission cycles of the plurality of transmission cycles, and generates a phase rotation amount change signal that controls a phase rotation amount,

N_e being an integer greater than one,

the phase rotation amount of the phase rotation amount change signal being constant within each of the plurality of transmission cycles,

the phase rotation amount of the phase rotation amount change signal being changed within the N_e transmission cycles according to the unit phase rotation amount and a predetermined pattern, and

29

- a transmission phase rotator which, in operation, assigns first phase rotations to the radar signals in accordance with the phase rotation amount change signal, and
- the radar receiver includes a reception phase rotator which, in operation, assigns second phase rotations, which are in directions opposite to directions of the first phase rotations, to the reflection wave signals in accordance with the phase rotation amount change signal.
2. The radar apparatus according to claim 1, wherein a difference between phase rotation amounts in patterns different from each other is 0 or π .
3. The radar apparatus according to claim 1, wherein the predetermined pattern is based on a pseudo random code.
4. The radar apparatus according to claim 1, wherein a total phase shift amount of the phase rotation amount change signal within N_e transmission cycles is an integral multiple of 2π .
5. The radar apparatus according to claim 4, wherein, a complementary code is used to generate the radar signals, and the phase rotation controller, in operation, assigns phase rotations such that a phase shift is not made within every two transmission cycles where a pair of codes constituting the complementary code are transmitted, and a predetermined phase shift is made between two transmission cycles.
6. The radar apparatus according to claim 1, wherein predetermined pattern is different between a plurality of radar apparatuses.
7. The radar apparatus according to claim 1, wherein the radar transmitter includes a plurality of transmission antennas, and the predetermined pattern is different between the transmission antennas.
8. A radar method, comprising:
transmitting radar signals in a plurality of transmission cycles; and
receiving reflection wave signals, the reflection wave signals being reflections of the radar signals on a target, wherein transmitting the radar signals includes:
assigning a unit phase rotation amount every N_e transmission cycles of the plurality of transmission cycles, and

30

- generating a phase rotation amount change signal that controls a phase rotation amount, and
assigning first phase rotations to the radar signals in accordance with the phase rotation amount change signal,
 N_e being an integer greater than one,
the phase rotation amount of the phase rotation amount change signal being constant within each of the plurality of transmission cycles,
the phase rotation amount of the phase rotation amount change signal being changed within the N_e transmission cycles according to the unit phase rotation amount and a predetermined pattern, and
receiving the reflection wave signals includes:
assigning second phase rotations, which are in directions opposite to directions of the first phase rotations, to the reflection wave signals in accordance with the phase rotation amount change signal.
9. The radar apparatus according to claim 1, wherein the phase rotation controller, in operation, changes the predetermined pattern every N_e transmission cycles.
10. A radar apparatus, comprising:
a phase rotation controller which, in operation, assigns a unit phase rotation amount every N_e transmission cycles of a plurality of transmission cycles, and generates a phase rotation amount change signal that controls a phase rotation amount,
 N_e being an integer greater than one,
the phase rotation amount of the phase rotation amount change signal being constant within each of the plurality of transmission cycles,
the phase rotation amount of the phase rotation amount change signal being changed within the N_e transmission cycles according to the unit phase rotation amount and a predetermined pattern;
a transmission phase rotator which, in operation, assigns first phase rotations to radar signals in accordance with the phase rotation amount change signal; and
a radar transmitter which, in operation, transmits the radar signals assigned the first phase rotations in the plurality of transmission cycles.

* * * * *