



US00RE49797E

(19) **United States**
(12) **Reissued Patent**
Nikitin et al.

(10) **Patent Number: US RE49,797 E**
(45) **Date of Reissued Patent: Jan. 9, 2024**

(54) **VERTICAL SPIN ORBIT TORQUE DEVICES**

(56)

References Cited

(71) Applicant: **Samsung Electronics Co., Ltd.**,
Gyeonggi-do (KR)

(72) Inventors: **Vladimir Nikitin**, Campbell, CA (US);
Dmytro Apalkov, San Jose, CA (US)

(73) Assignee: **Samsung Electronics Co., Ltd.**,
Yongin-si (KR)

(21) Appl. No.: **17/308,585**

(22) Filed: **May 5, 2021**

U.S. PATENT DOCUMENTS

6,351,410 B1 2/2002 Nakao
6,768,152 B2* 7/2004 Higo B82Y 10/00
257/294

(Continued)

FOREIGN PATENT DOCUMENTS

CN 101621113 A 1/2010
CN 103887425 A 6/2014

(Continued)

OTHER PUBLICATIONS

Chinese Office Action dated Jul. 27, 2023, issued in corresponding Chinese Patent Application No. 201910131941.1 (9 pages).

Primary Examiner — Tuan H Nguyen
(74) *Attorney, Agent, or Firm* — Lewis Roca Rothgerber Christie LLP

Related U.S. Patent Documents

Reissue of:

(64) Patent No.: **10,411,184**
Issued: **Sep. 10, 2019**
Appl. No.: **15/968,514**
Filed: **May 1, 2018**

U.S. Applications:

(60) Provisional application No. 62/637,596, filed on Mar. 2, 2018.

(51) **Int. Cl.**
H01L 43/08 (2006.01)
H01L 27/22 (2006.01)
(Continued)

(52) **U.S. Cl.**
CPC **H10N 52/00** (2023.02); **G11C 11/155**
(2013.01); **G11C 11/161** (2013.01);
(Continued)

(58) **Field of Classification Search**
CPC H01L 43/08; H01L 27/228; H01L 43/02;
H01L 43/12; G11C 11/161;
(Continued)

(57)

ABSTRACT

A magnetic device and method for programming the magnetic device are described. The magnetic device includes a plurality of magnetic junctions and at least one spin-orbit interaction (SO) active layer having a plurality of sides *and an axis*. The SO active layer(s) carry a current in direction(s) substantially [perpendicular to the plurality of sides] *along the axis*. Each of the magnetic junction(s) is adjacent to the sides and substantially surrounds a portion of the SO active layer. Each magnetic junction includes a free layer, a reference layer and a nonmagnetic spacer layer between the pinned and free layers. The SO active layer(s) exert a SO torque on the free layer due to the current passing through the SO active layer(s). The free layer is switchable between stable magnetic states. The free layer may be written using the current and, in some aspects, another current driven through the magnetic junction.

16 Claims, 11 Drawing Sheets

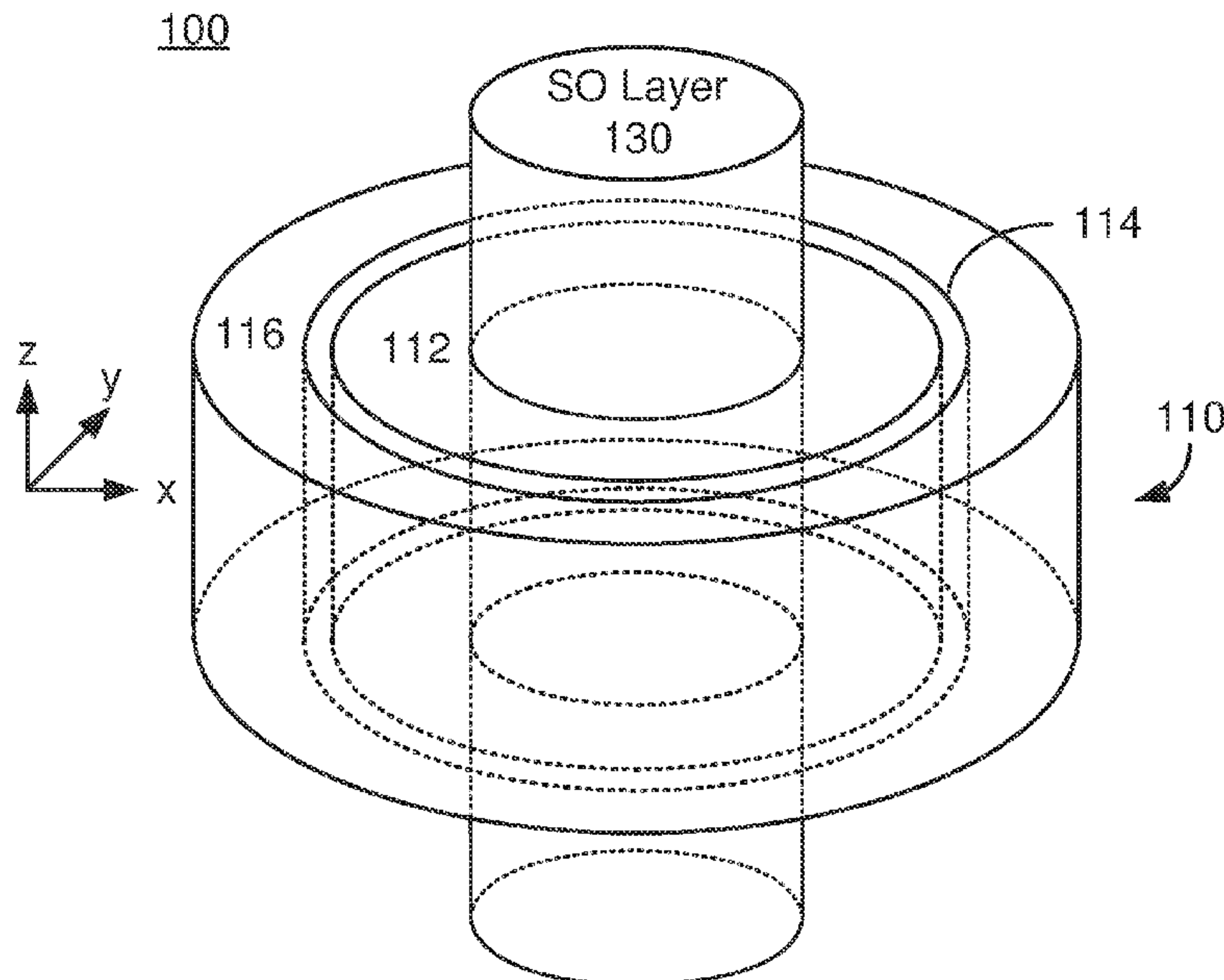

US RE49,797 E

- | | | | | | | |
|------|---|--|-------------------|---------|--------------------|------------------------|
| (51) | Int. Cl. | | 7,405,961 B2 | 7/2008 | Haratani | |
| | <i>H01L 43/02</i> | (2006.01) | 7,460,393 B2 | 12/2008 | Haratani | |
| | <i>G11C 11/16</i> | (2006.01) | 7,885,105 B2 | 2/2011 | Li | |
| | <i>H01F 10/32</i> | (2006.01) | 7,944,736 B2 * | 5/2011 | Dieny | H01L 43/08
360/314 |
| | <i>H01L 43/12</i> | (2006.01) | | | | |
| | <i>H10N 52/00</i> | (2023.01) | 8,520,432 B2 | 8/2013 | Lu | |
| | <i>H10N 50/10</i> | (2023.01) | 9,443,905 B1 | 9/2016 | Bandic et al. | |
| | <i>H10B 61/00</i> | (2023.01) | 9,490,297 B1 * | 11/2016 | Braganca | H01L 21/28 |
| | <i>H10N 50/80</i> | (2023.01) | 9,490,421 B2 | 11/2016 | Apalkov | |
| | <i>H10N 50/01</i> | (2023.01) | 2003/0183889 A1 * | 10/2003 | Kajiyama | G11C 11/155
257/421 |
| | <i>G11C 11/155</i> | (2006.01) | 2006/0279980 A1 | 12/2006 | Haratani | |
| (52) | U.S. Cl. | | 2007/0236978 A1 * | 10/2007 | Wilson | G11C 11/14
365/55 |
| | CPC | <i>G11C 11/1659</i> (2013.01); <i>G11C 11/1673</i>
(2013.01); <i>G11C 11/1675</i> (2013.01); <i>H01F</i>
<i>10/329</i> (2013.01); <i>H01F 10/3254</i> (2013.01);
<i>H01F 10/3286</i> (2013.01); <i>H10B 61/22</i>
(2023.02); <i>H10N 50/01</i> (2023.02); <i>H10N</i>
<i>50/10</i> (2023.02); <i>H10N 50/80</i> (2023.02);
<i>H01F 10/3272</i> (2013.01) | 2010/0003767 A1 * | 1/2010 | Cho | H01L 43/08
438/3 |
| | | | 2012/0294077 A1 | 11/2012 | Liu et al. | |
| | | | 2014/0056060 A1 * | 2/2014 | Khvalkovskiy | H01L 43/08
365/158 |
| | | | 2014/0175577 A1 * | 6/2014 | Apalkov | H10N 50/10
257/421 |
| | | | 2015/0035099 A1 | 2/2015 | Apalkov et al. | |
| (58) | Field of Classification Search | | 2017/0148848 A1 * | 5/2017 | Ahn | H01L 43/10 |
| | CPC | G11C 11/1673; G11C 11/1675; H01F
10/3254; H01F 10/3286; H01F 10/329 | 2018/0151212 A1 * | 5/2018 | Lim | G11C 11/1693 |
| | See application file for complete search history. | | 2018/0268888 A1 * | 9/2018 | Ohsawa | H01L 27/222 |

FOREIGN PATENT DOCUMENTS

- (56) **References Cited**
- U.S. PATENT DOCUMENTS

6,781,872 B2 8/2004 Saito
6,977,401 B2 12/2005 Hosotani

CN 107658382 A 2/2018
KR 10-2014-0007475 1/2014

* cited by examiner

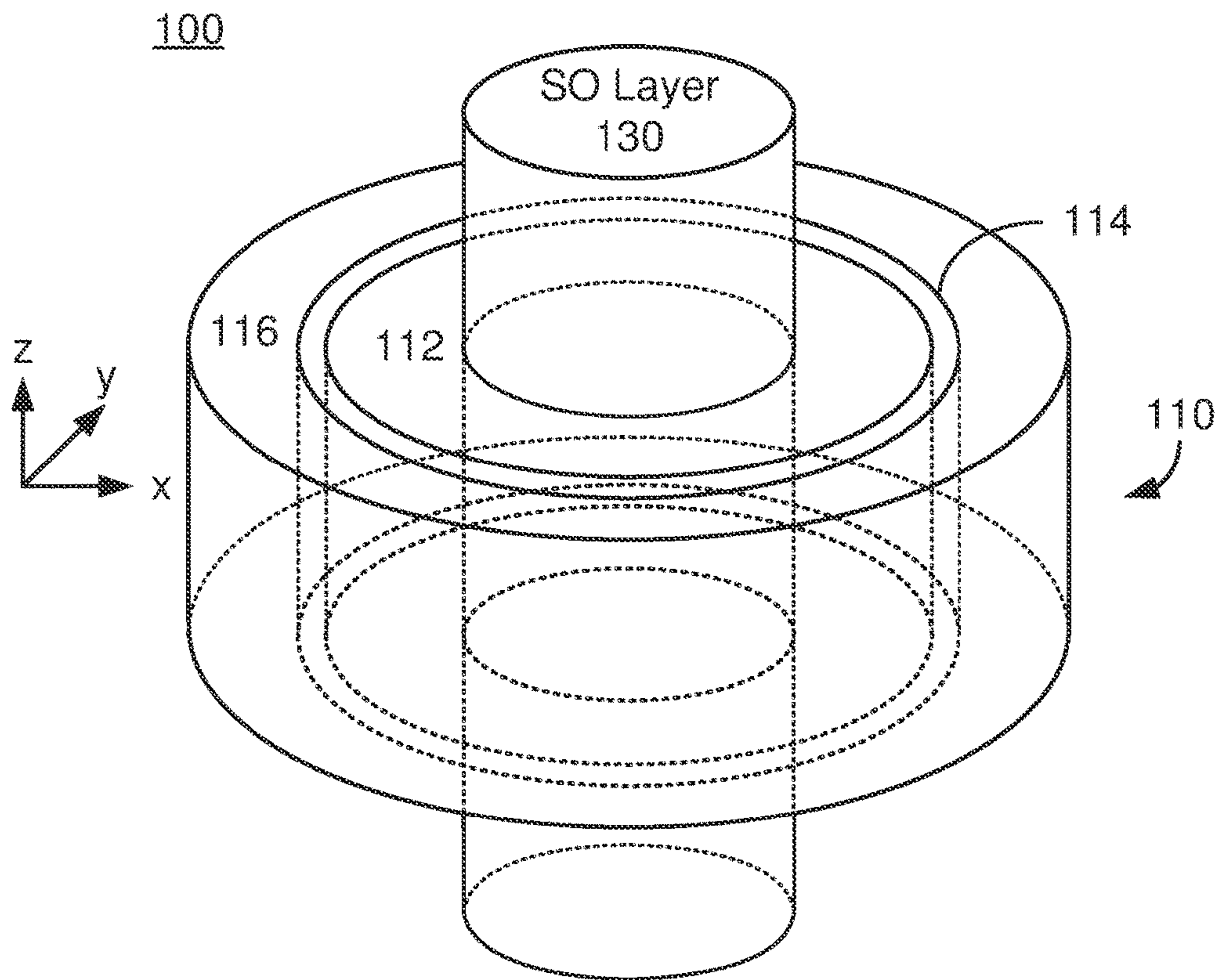

FIG. 1A

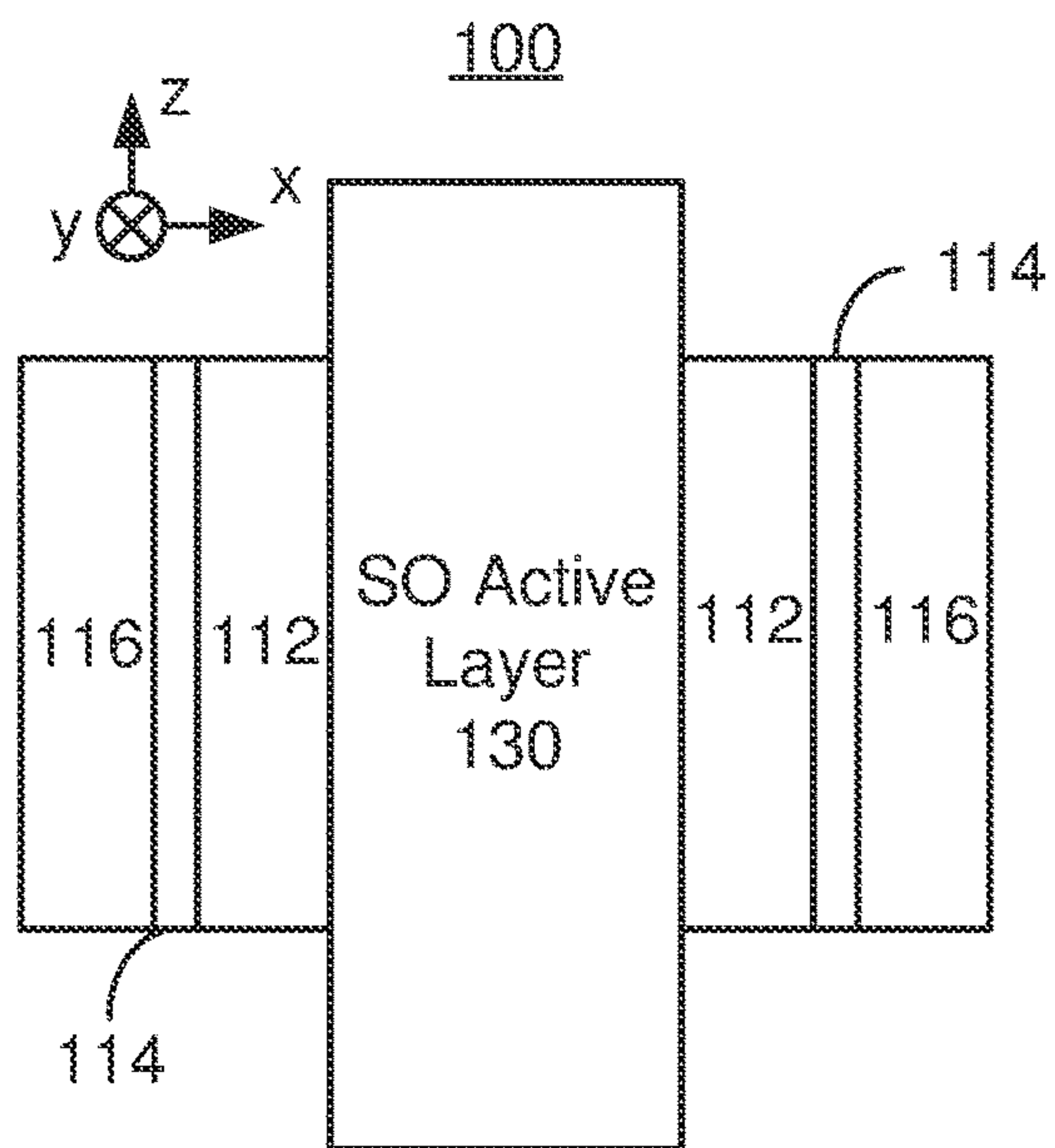

Fig. 1B

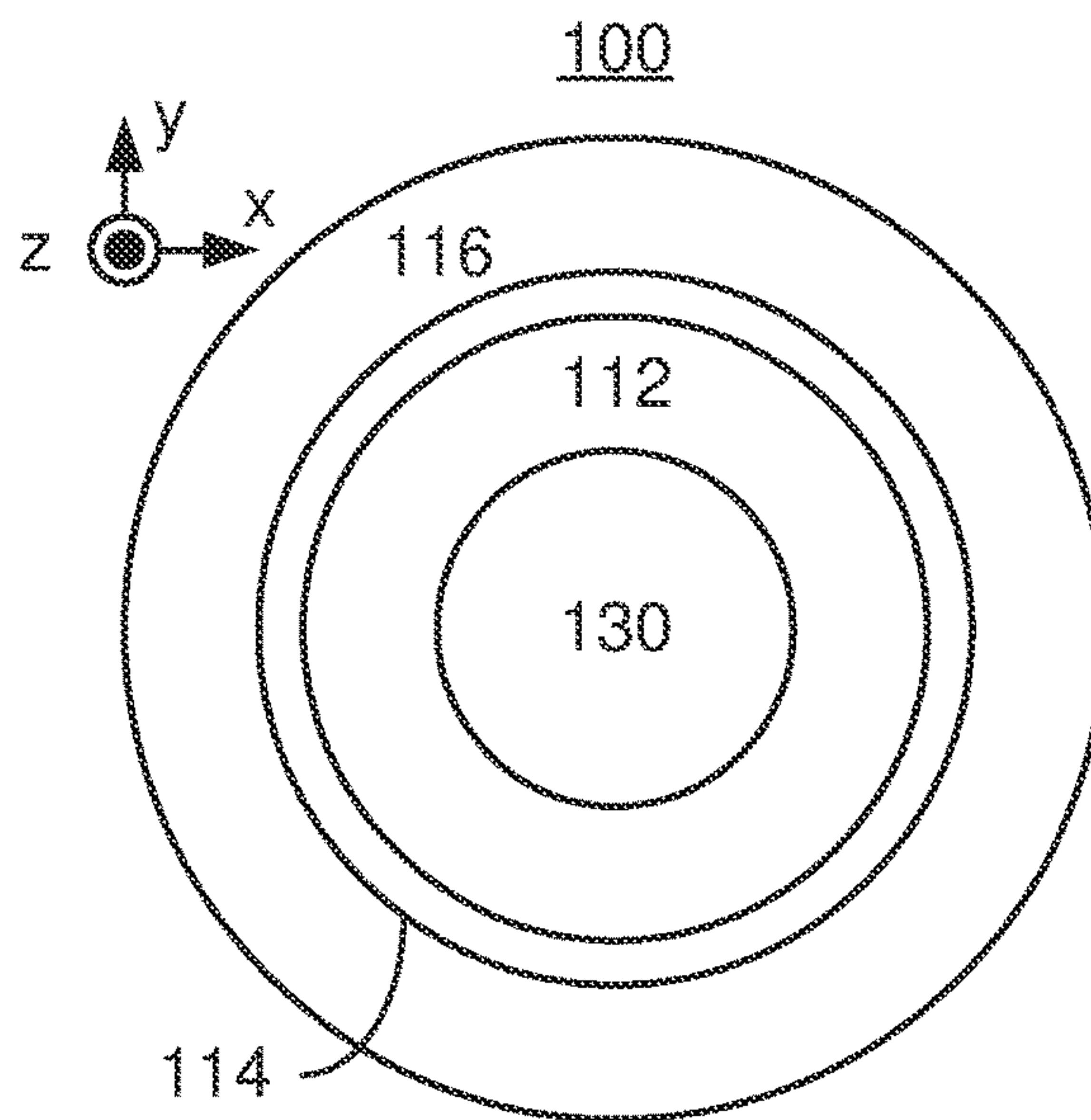

FIG. 1C

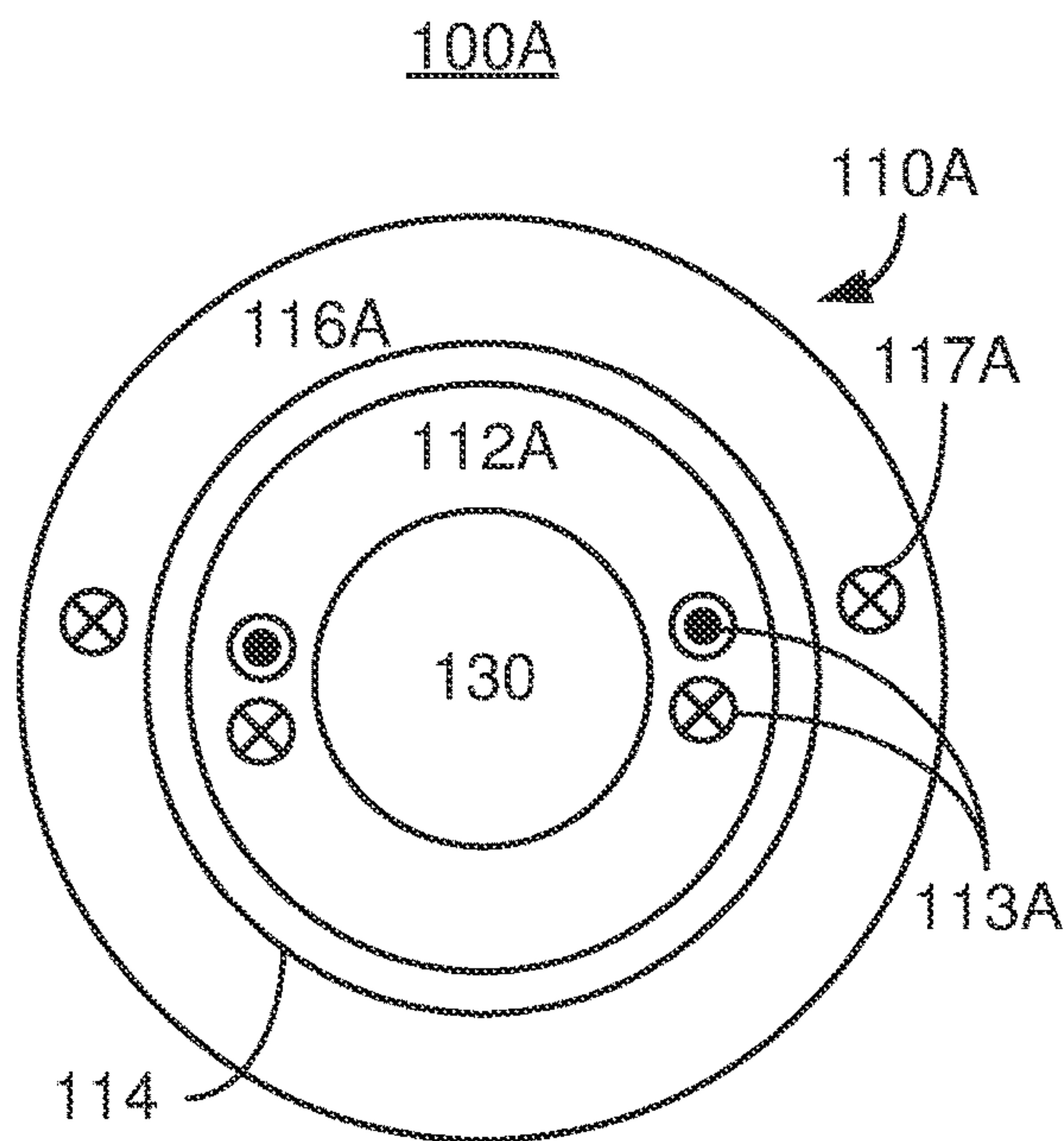

FIG. 2A

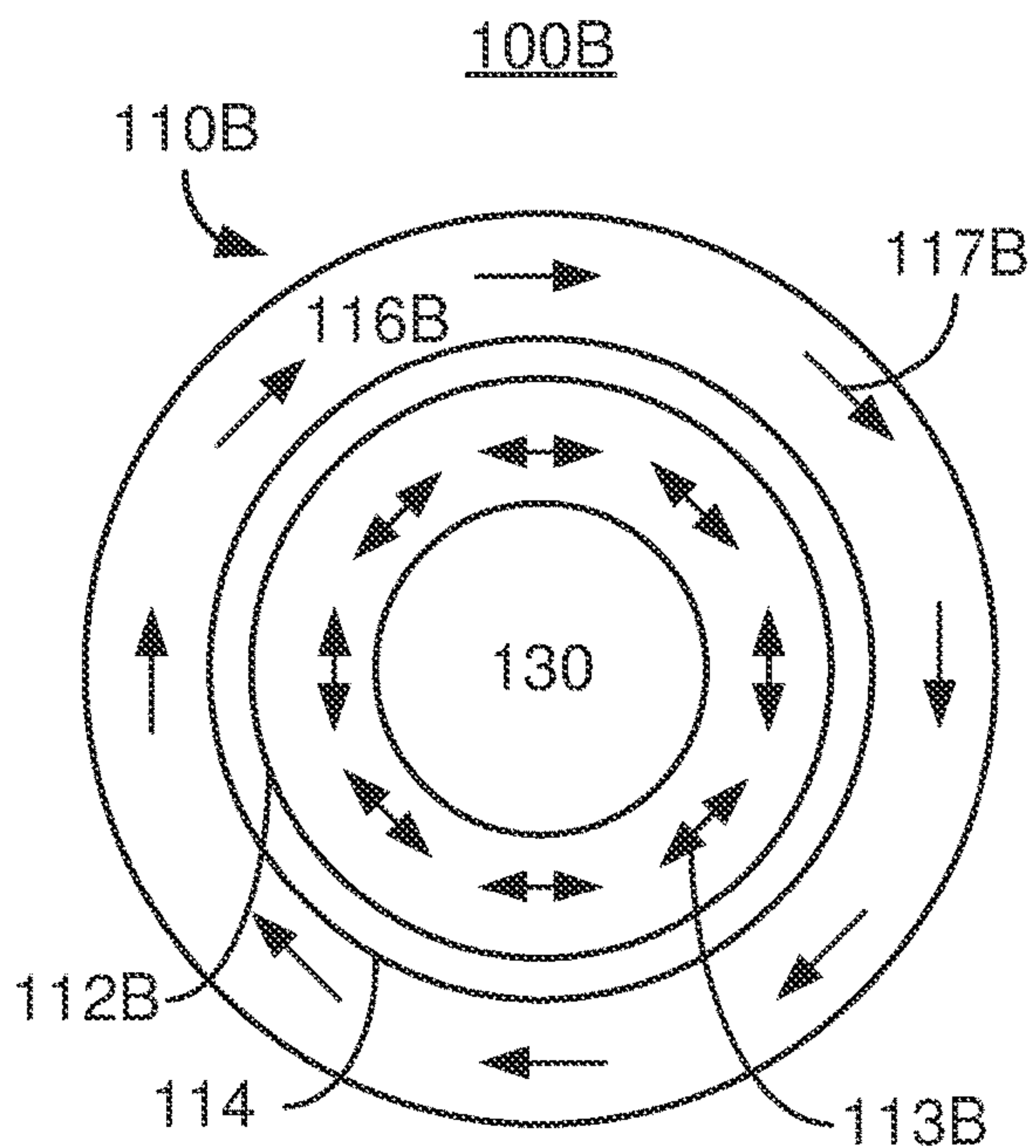

FIG. 2B

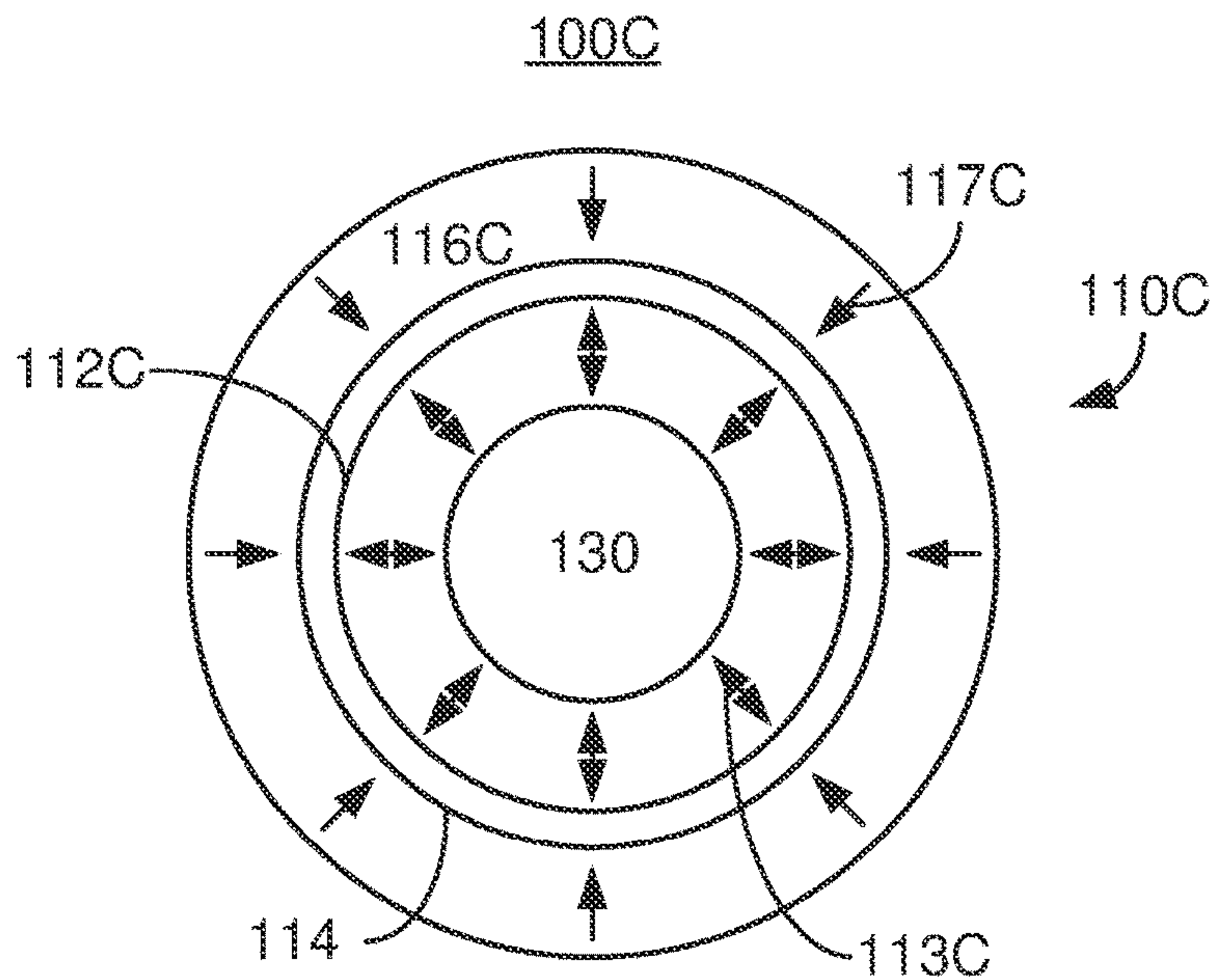

FIG. 2C

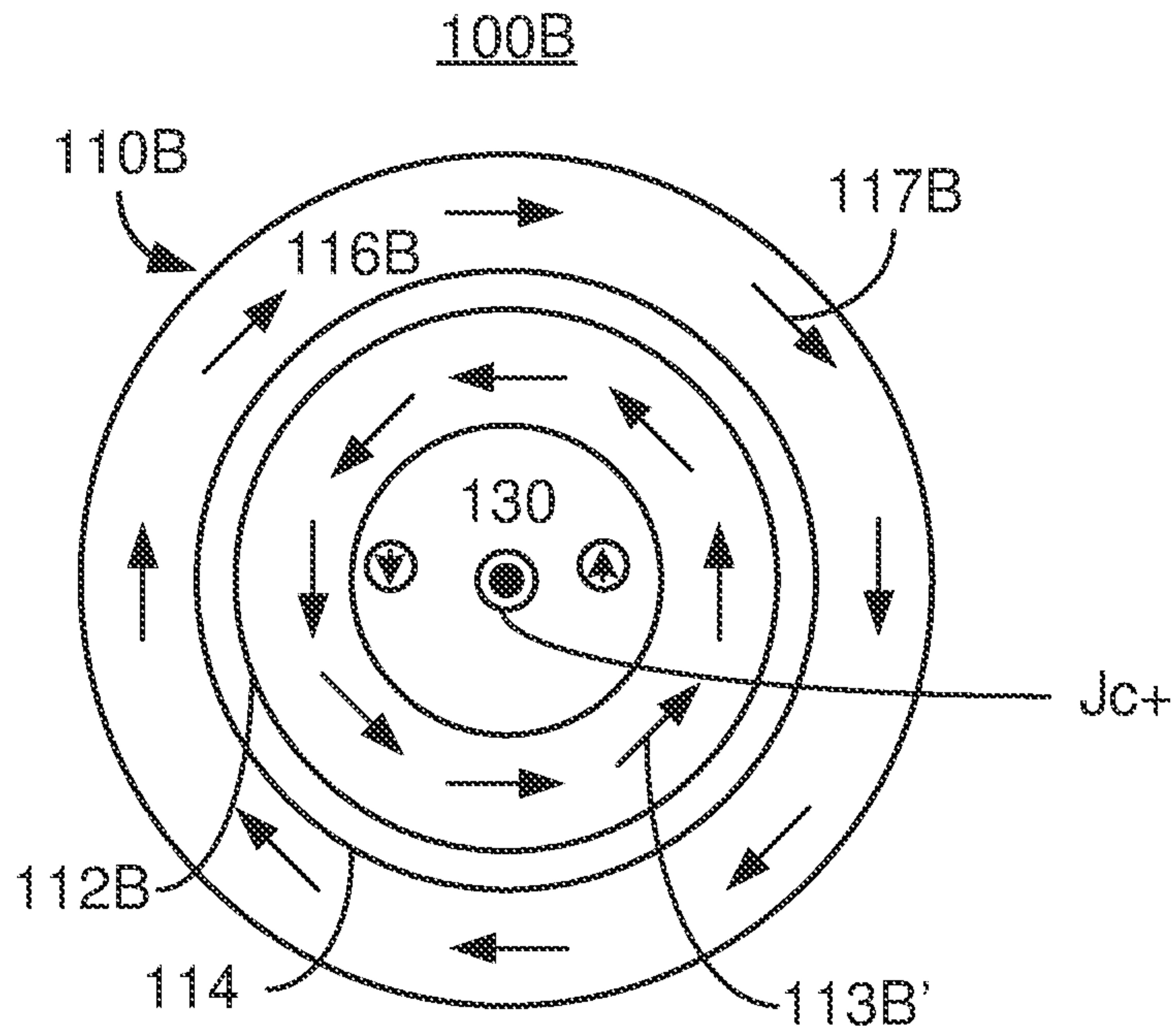

FIG. 3A

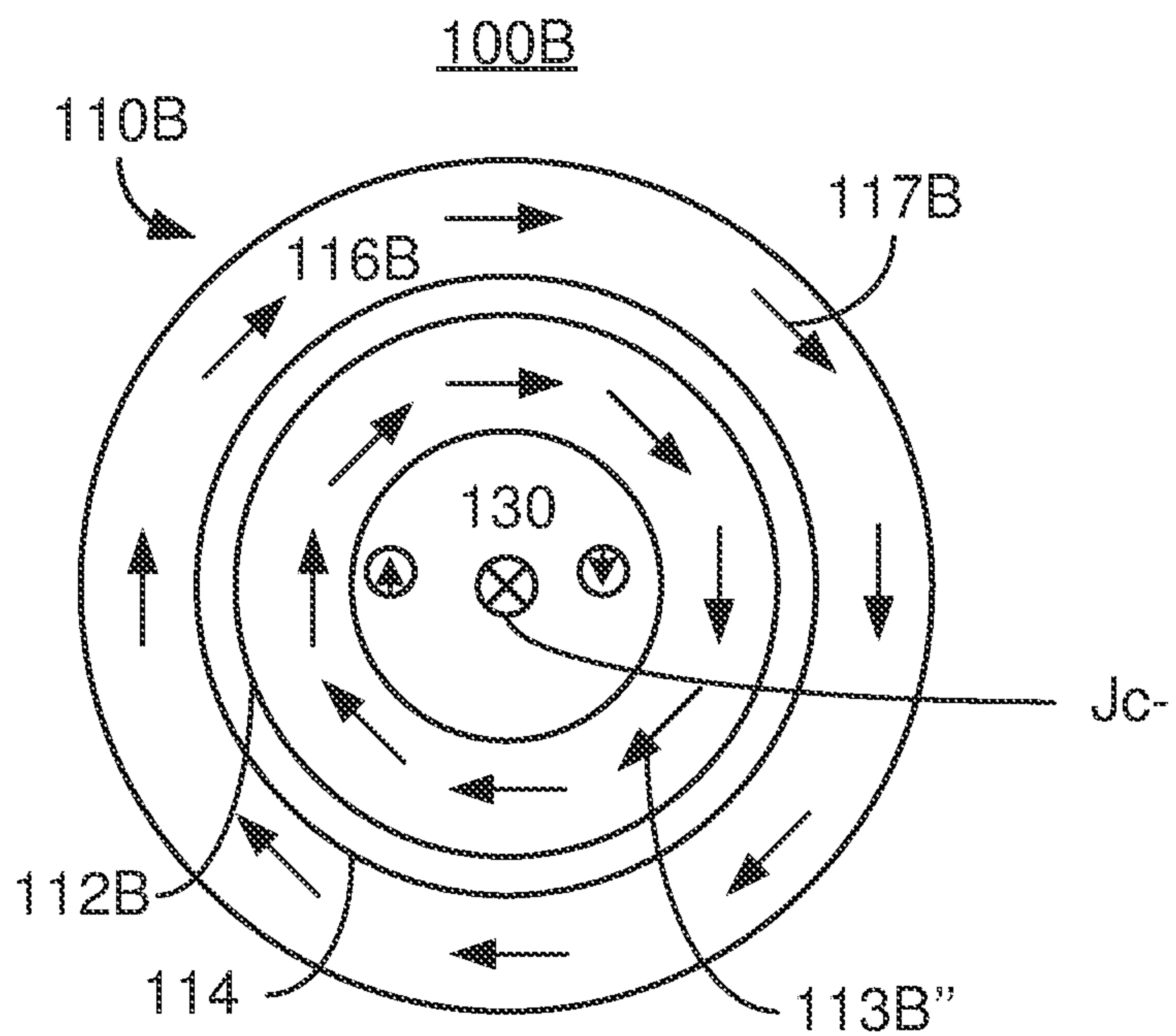

FIG. 3B

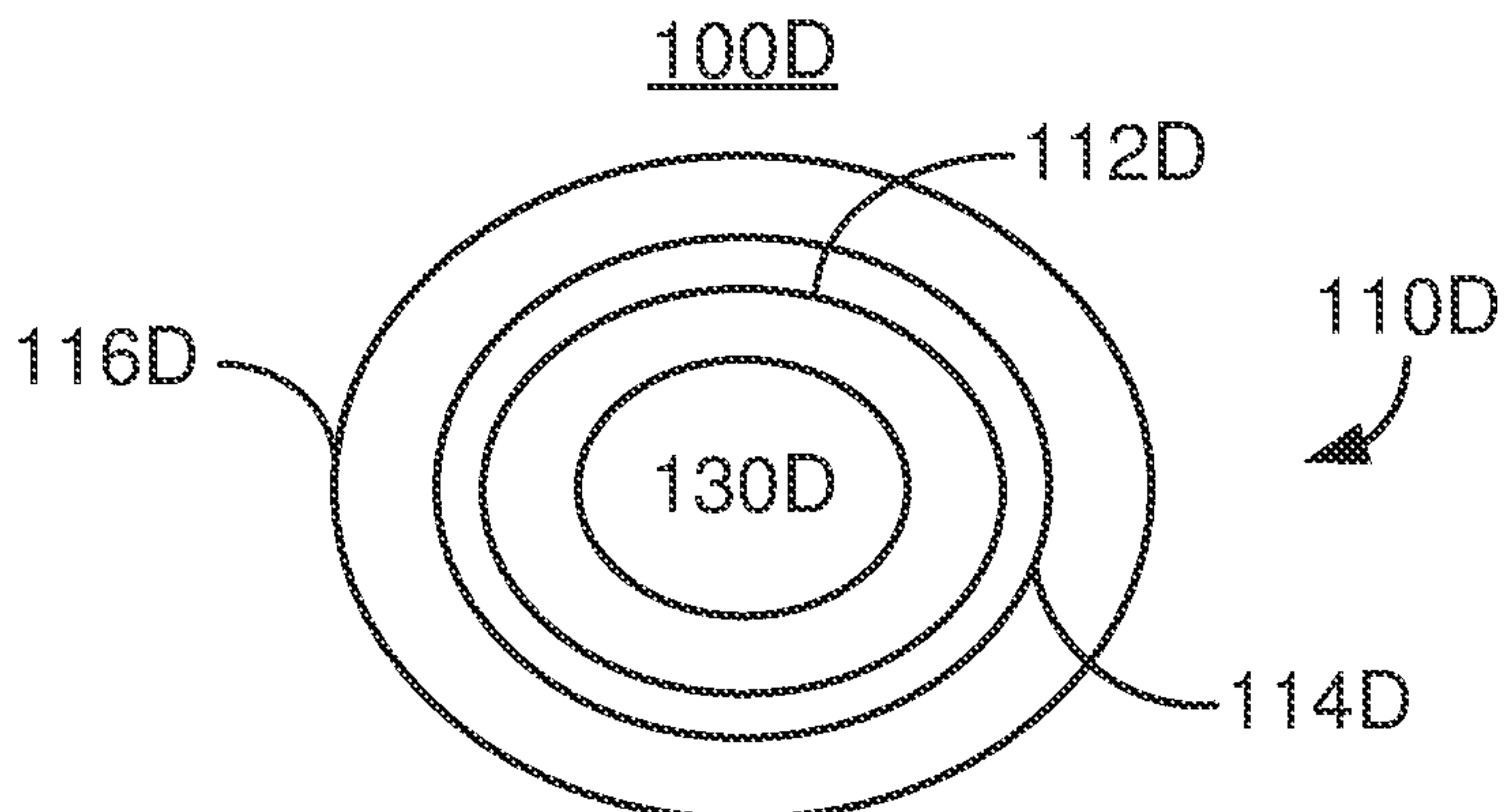

FIG. 4

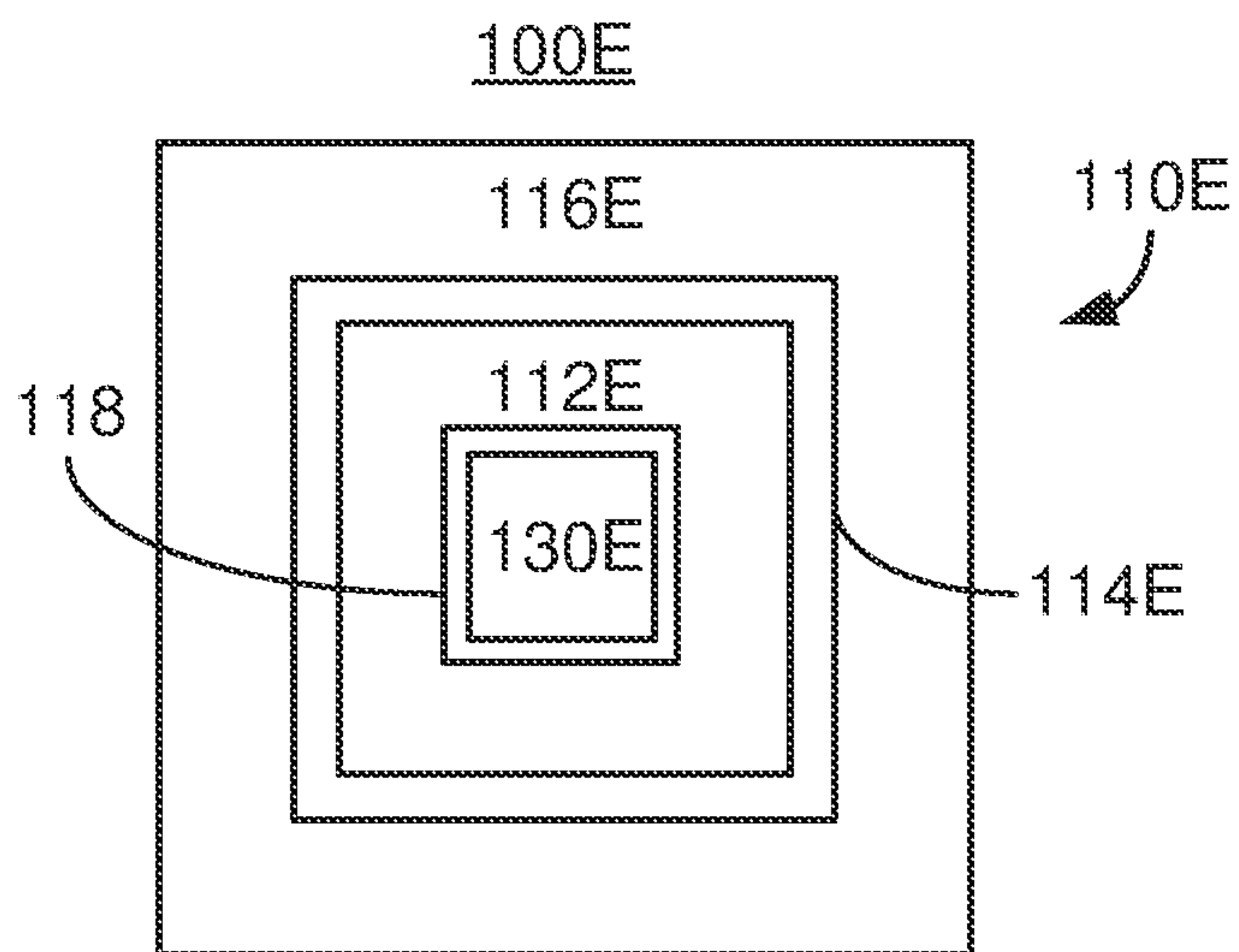

FIG. 5

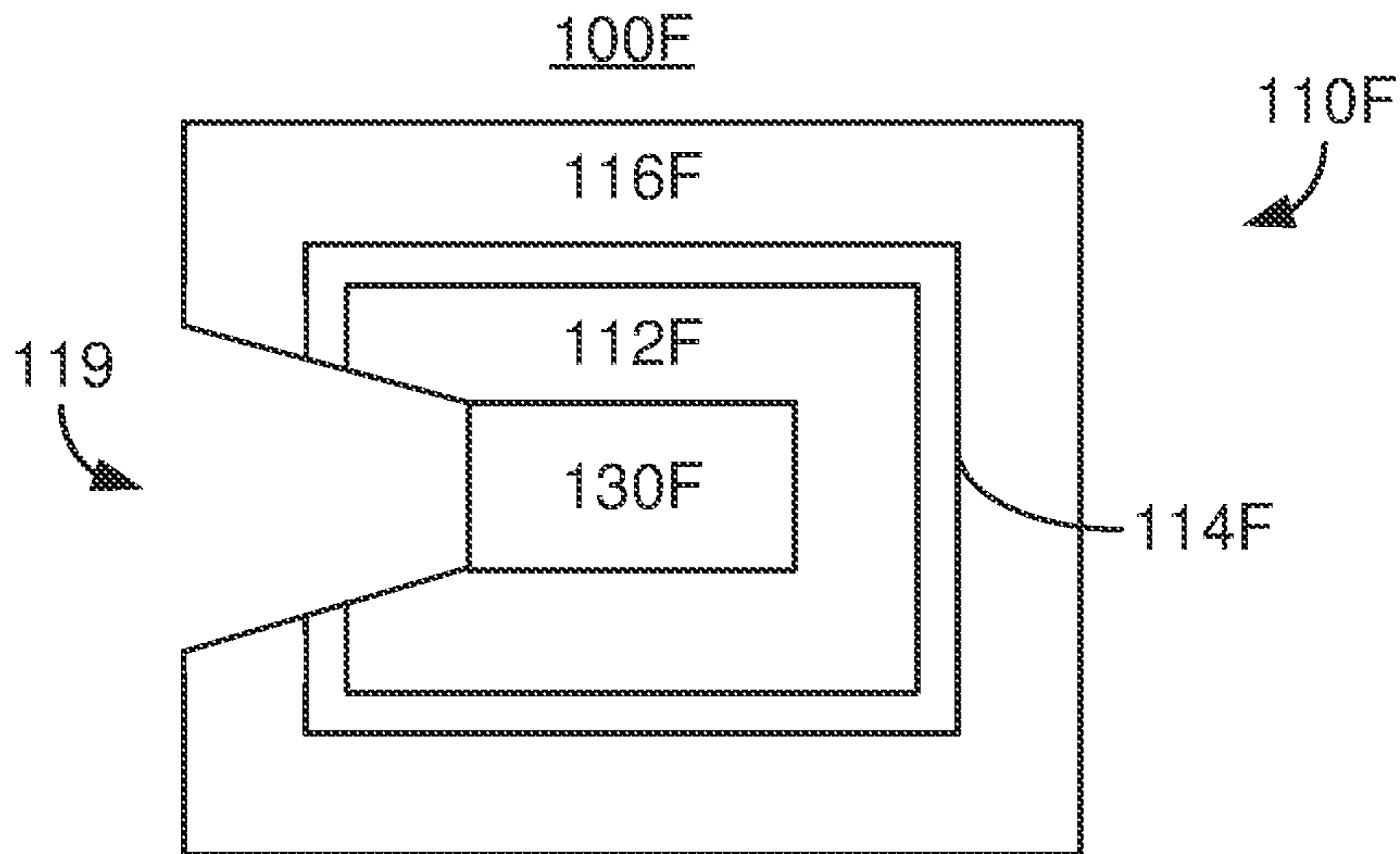

FIG. 6

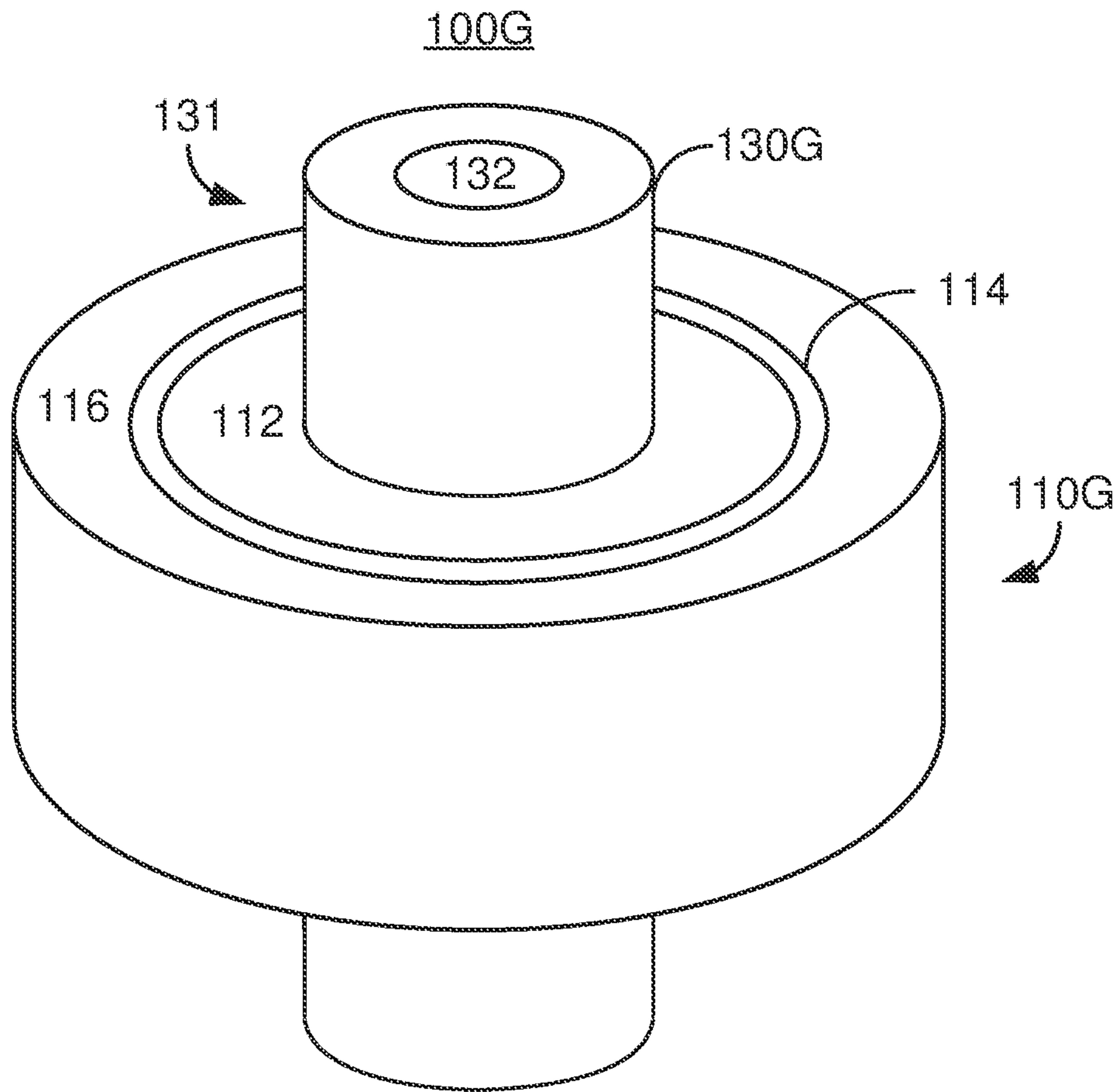

FIG. 7A

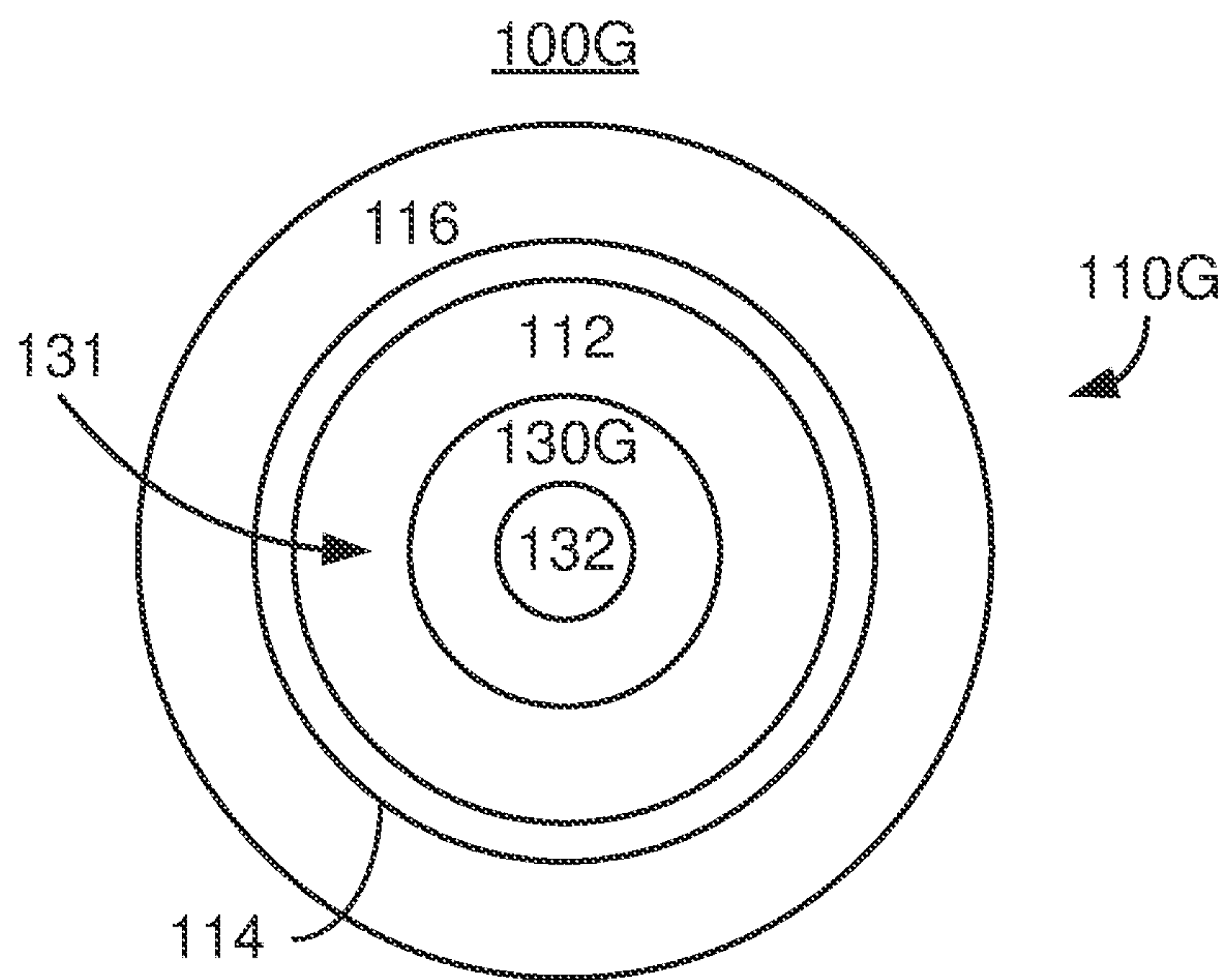

FIG. 7B

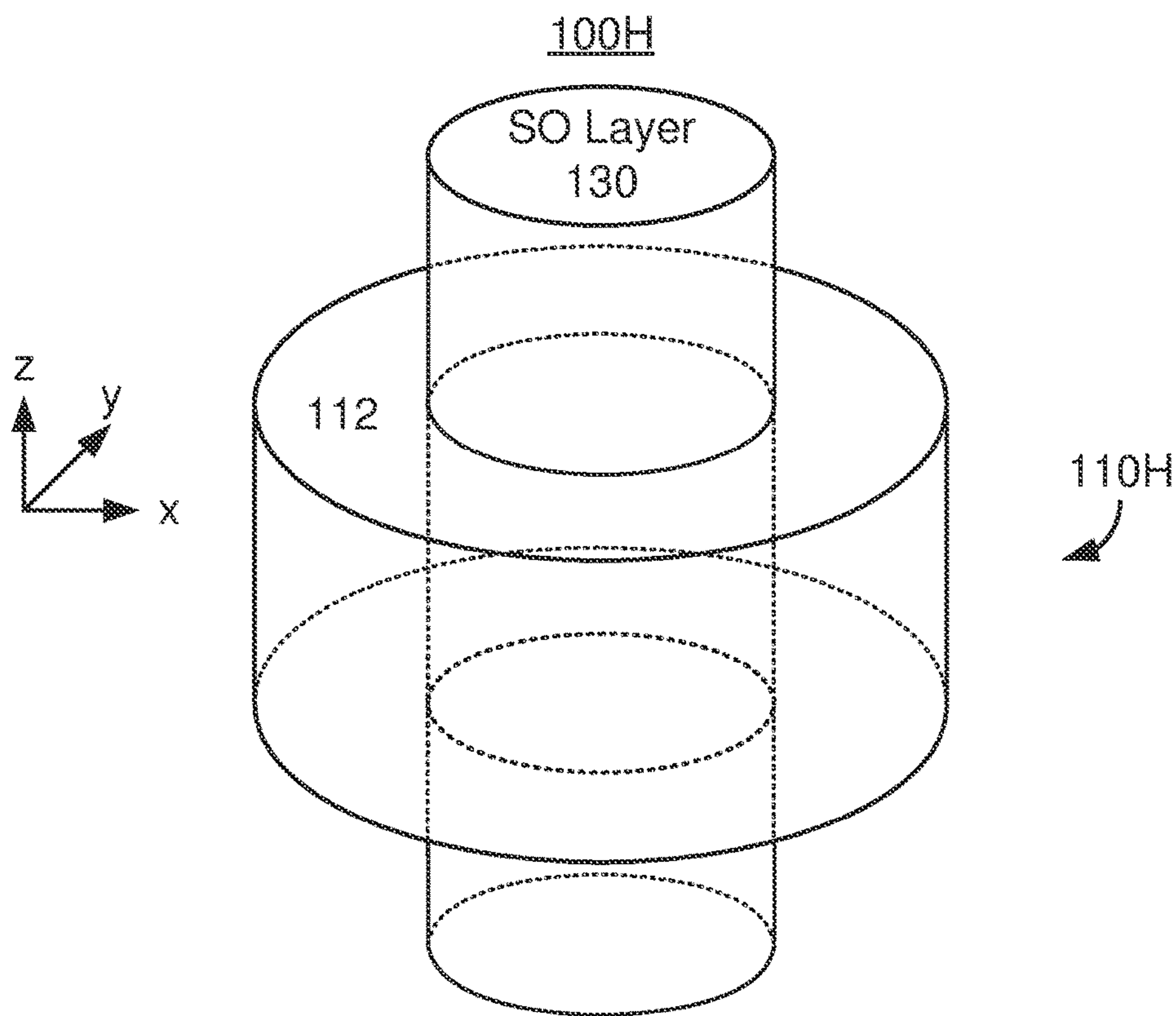

FIG. 8A

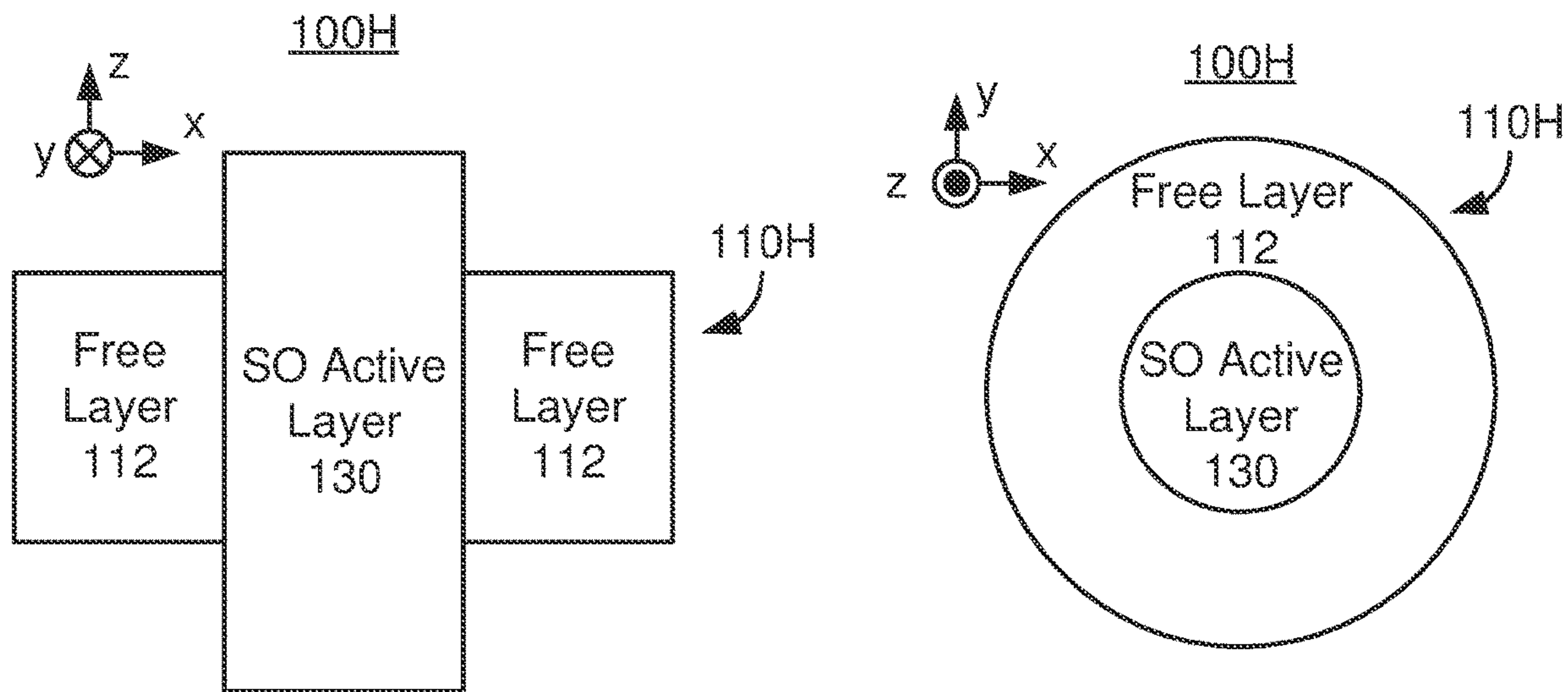

Fig. 8B

FIG. 8C

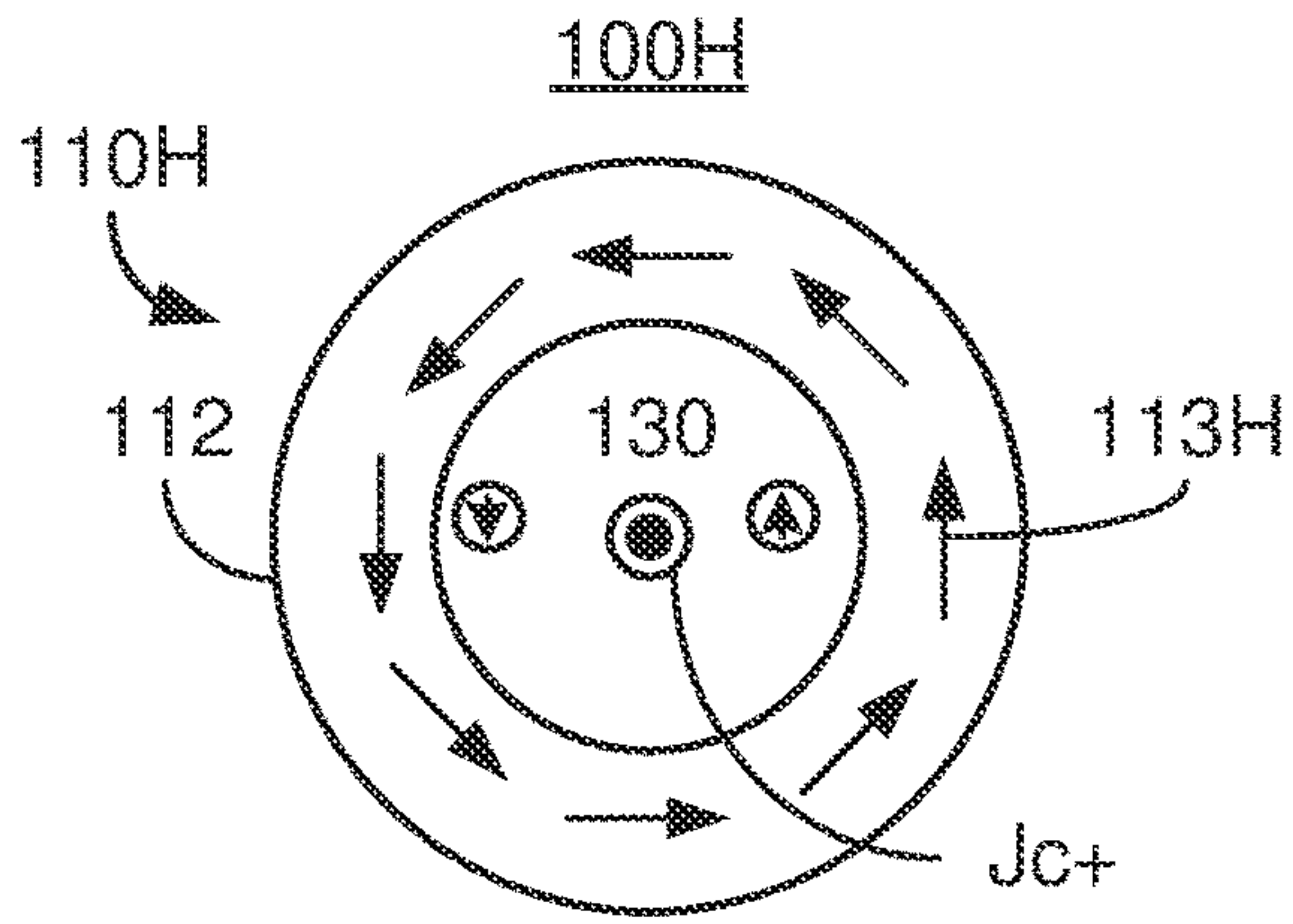

Fig. 9A

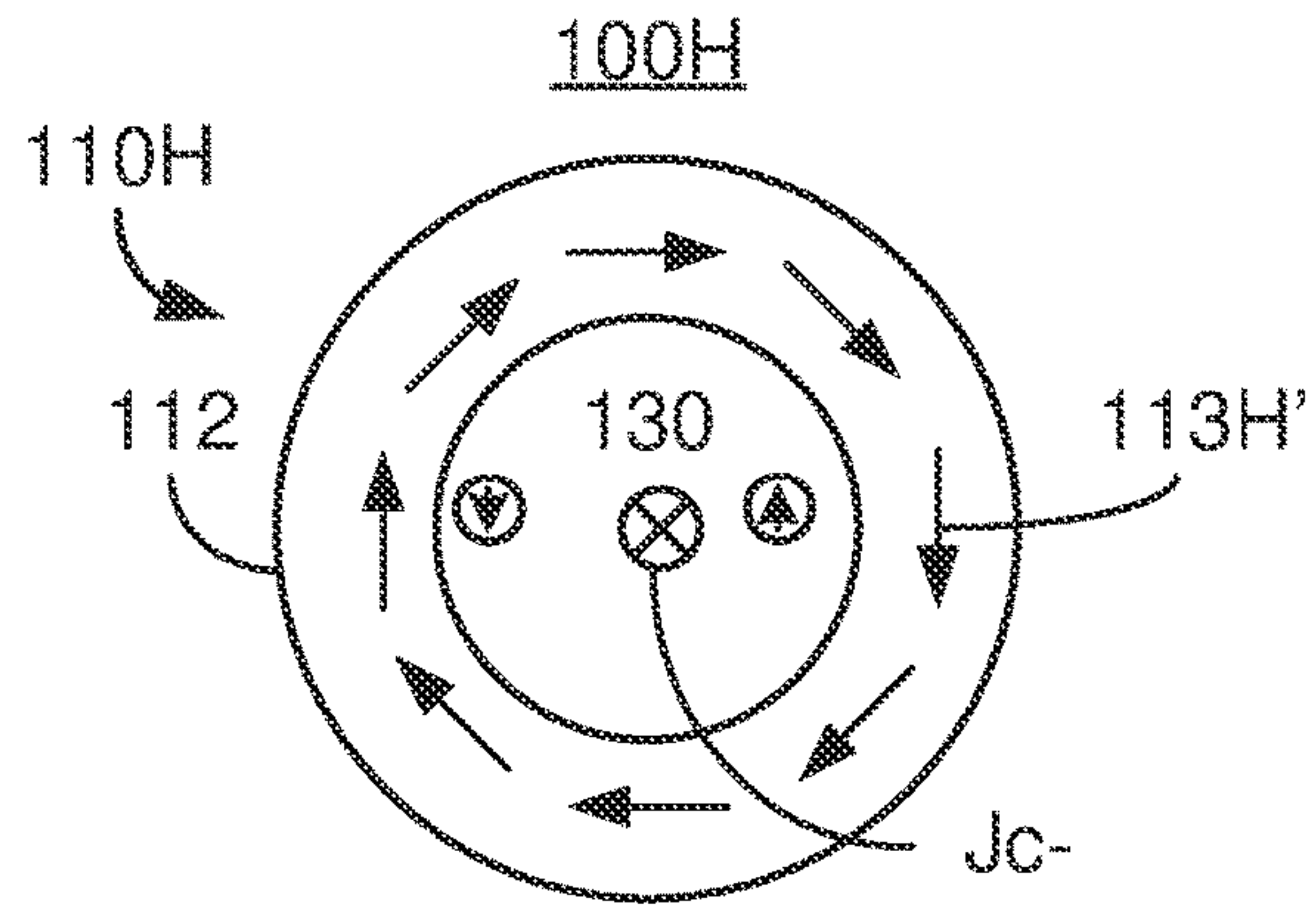

Fig. 9B

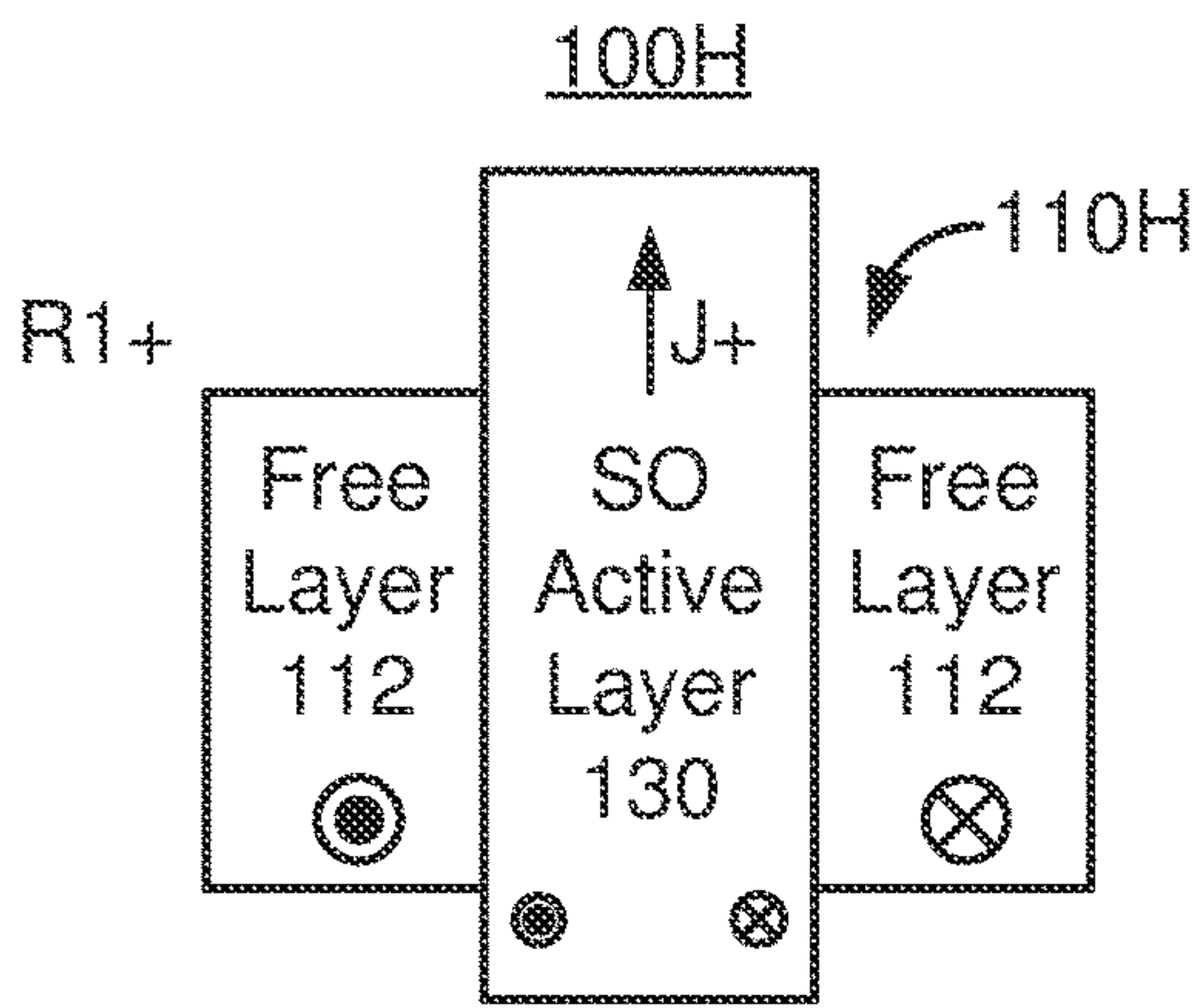

Fig. 9C

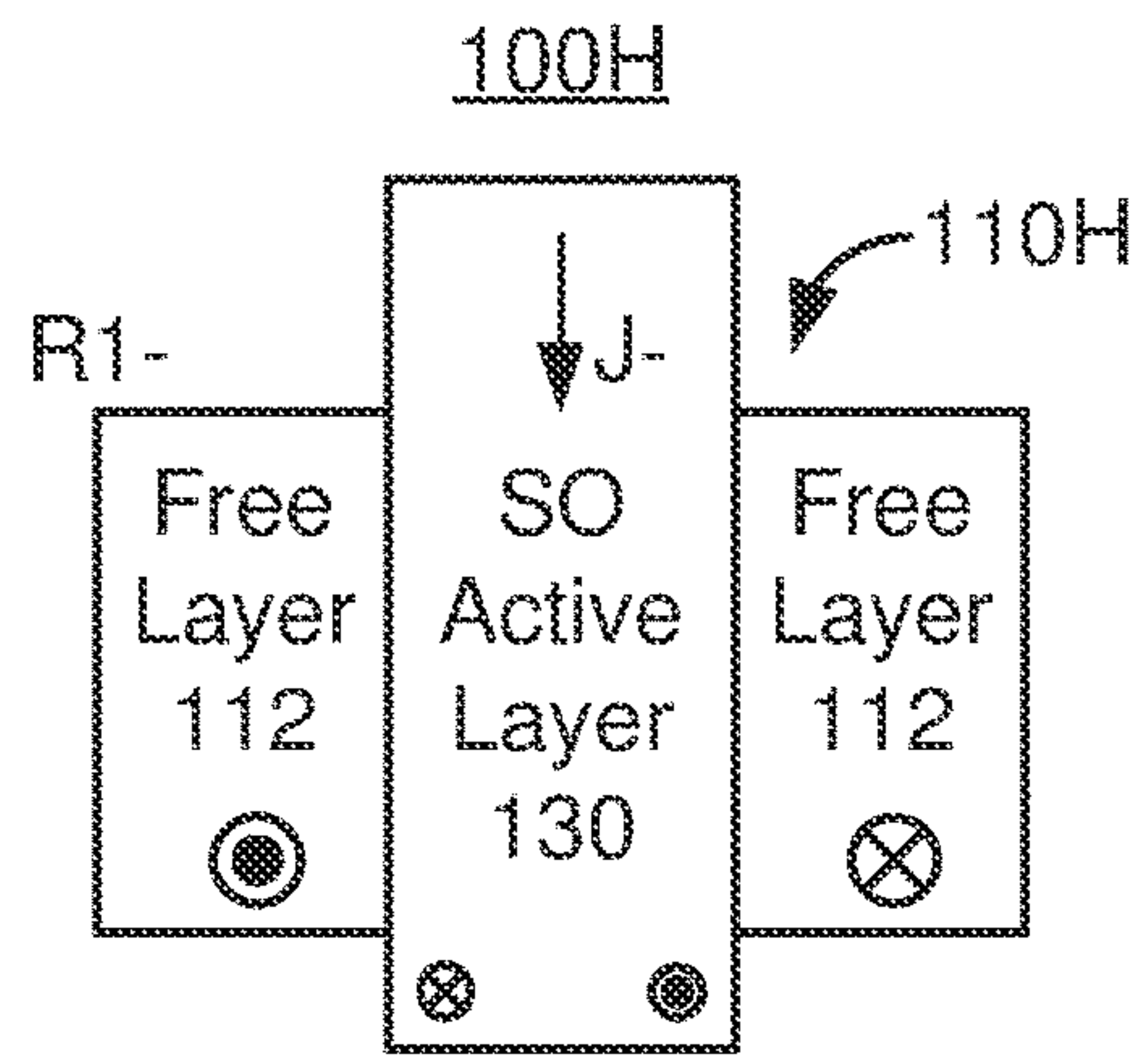

Fig. 9D

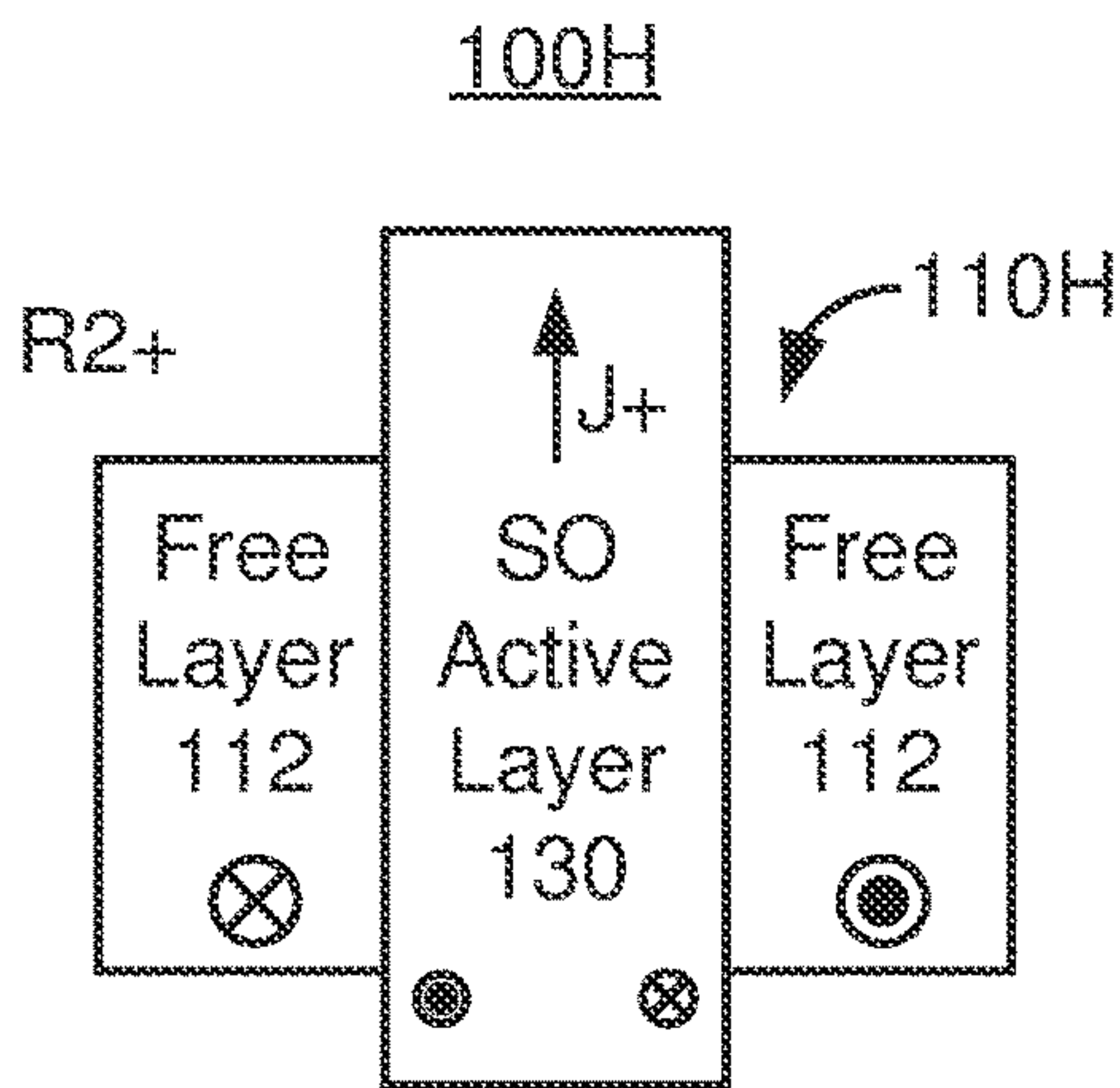

Fig. 9E

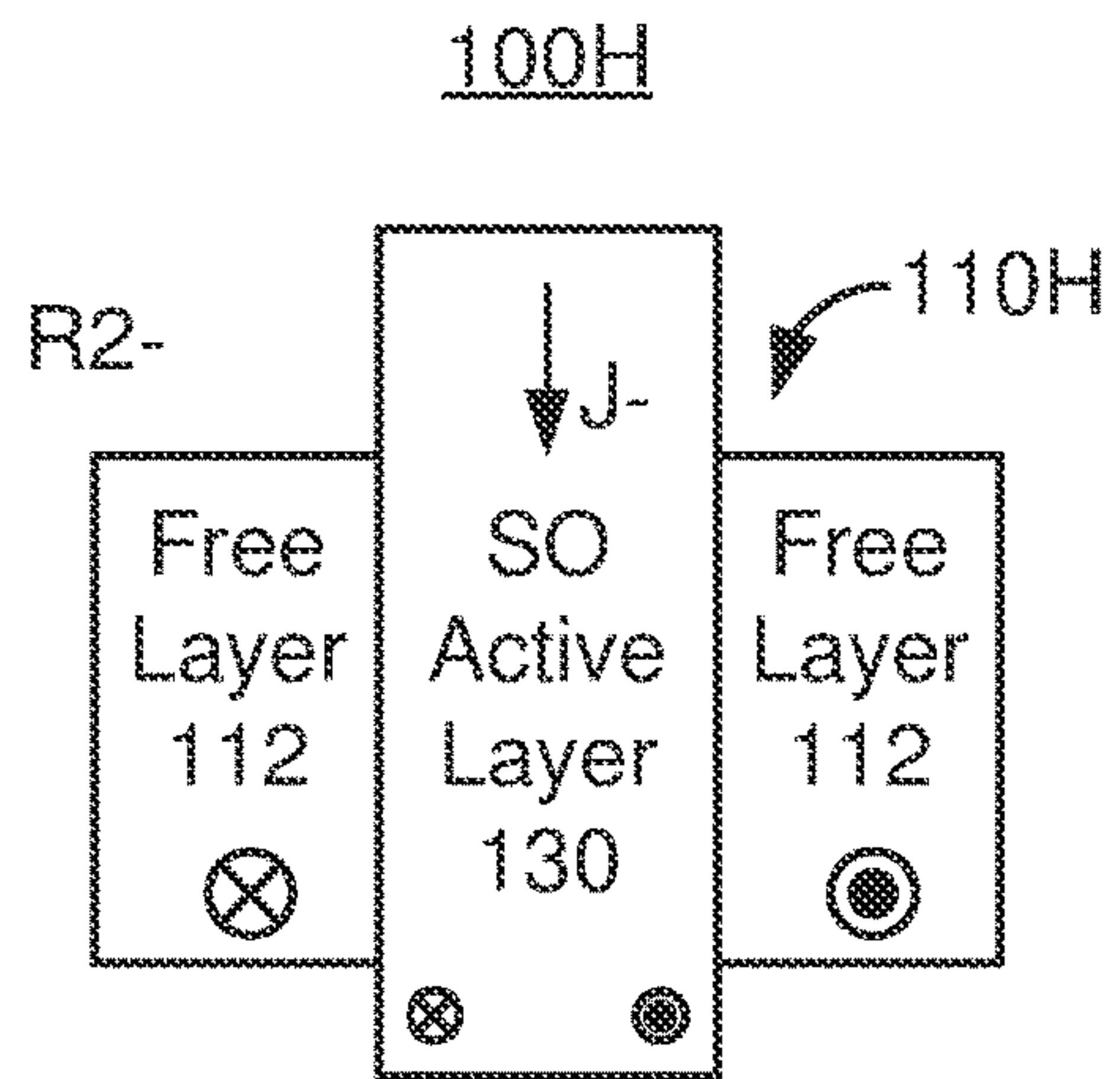

Fig. 9F

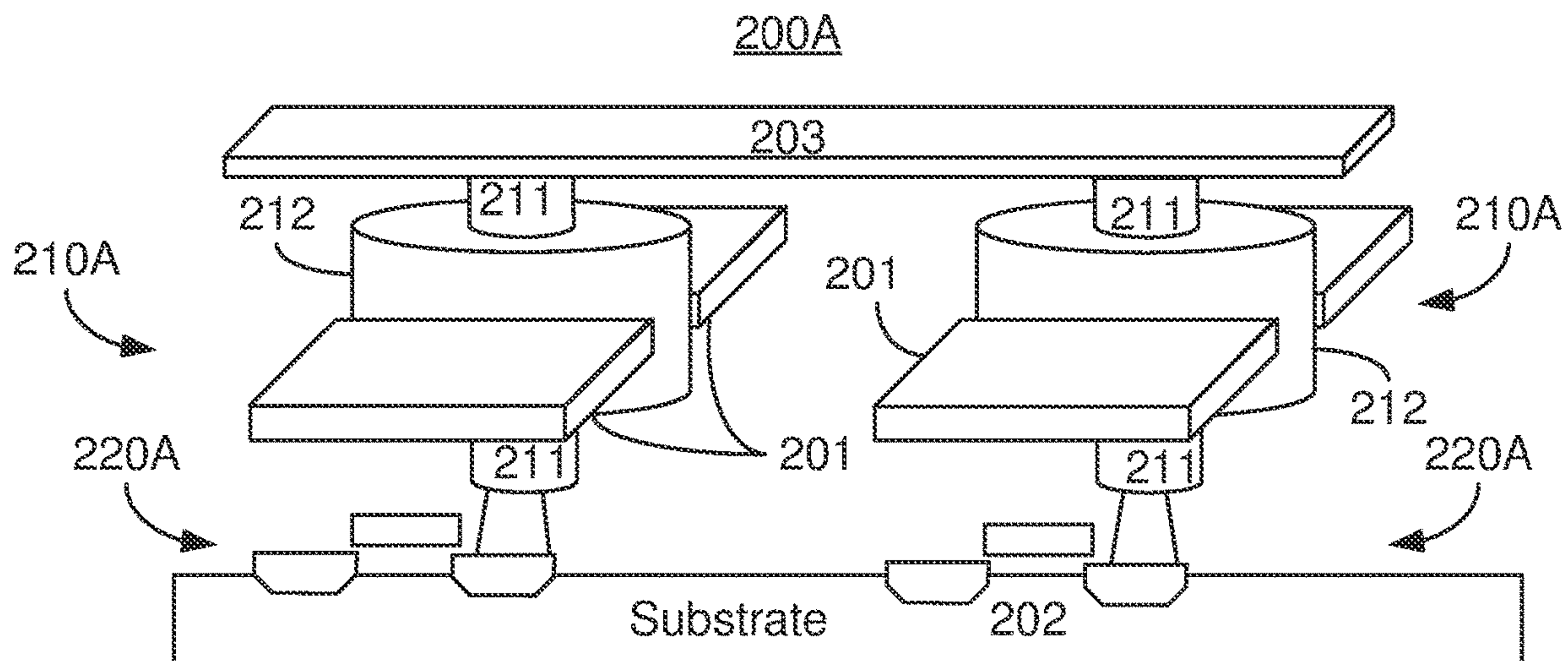

FIG. 10

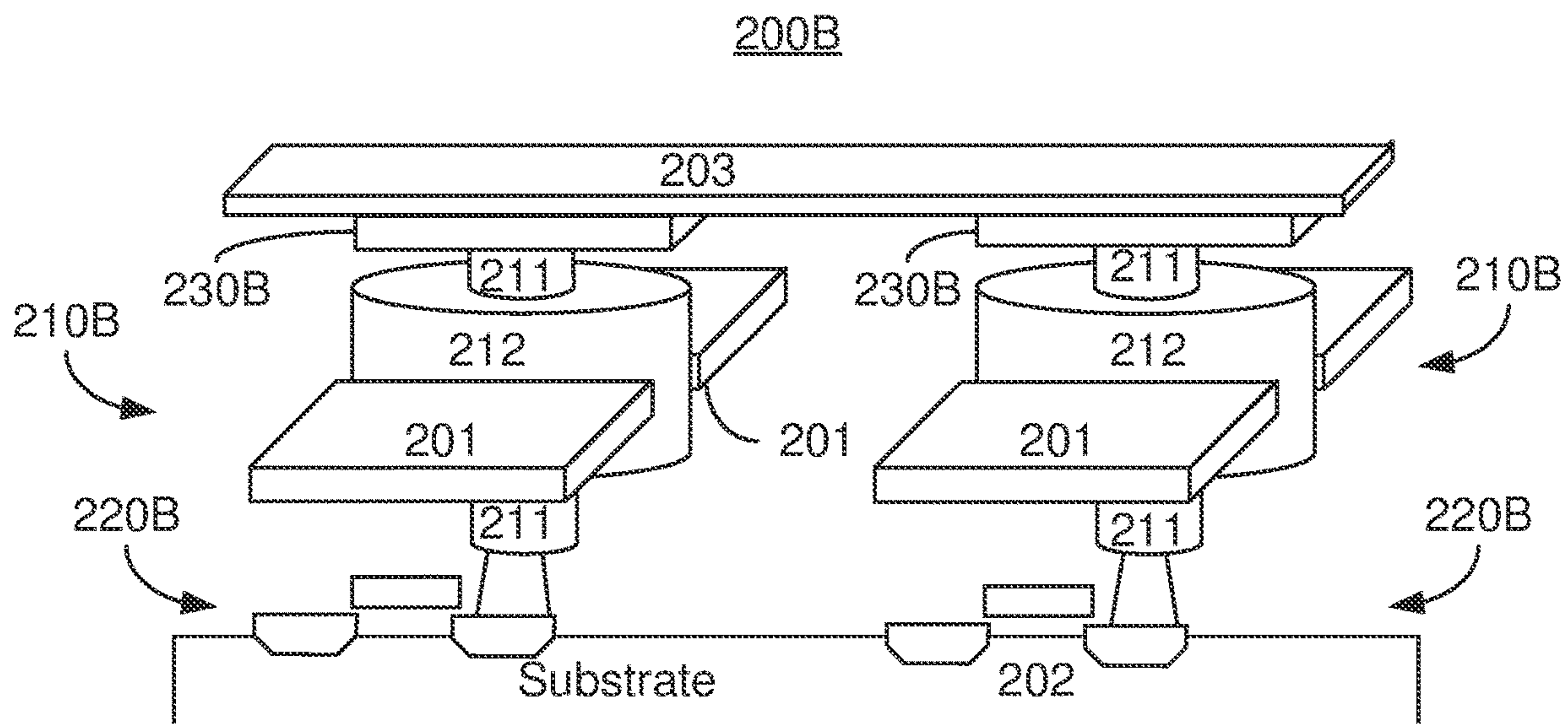

FIG. 11

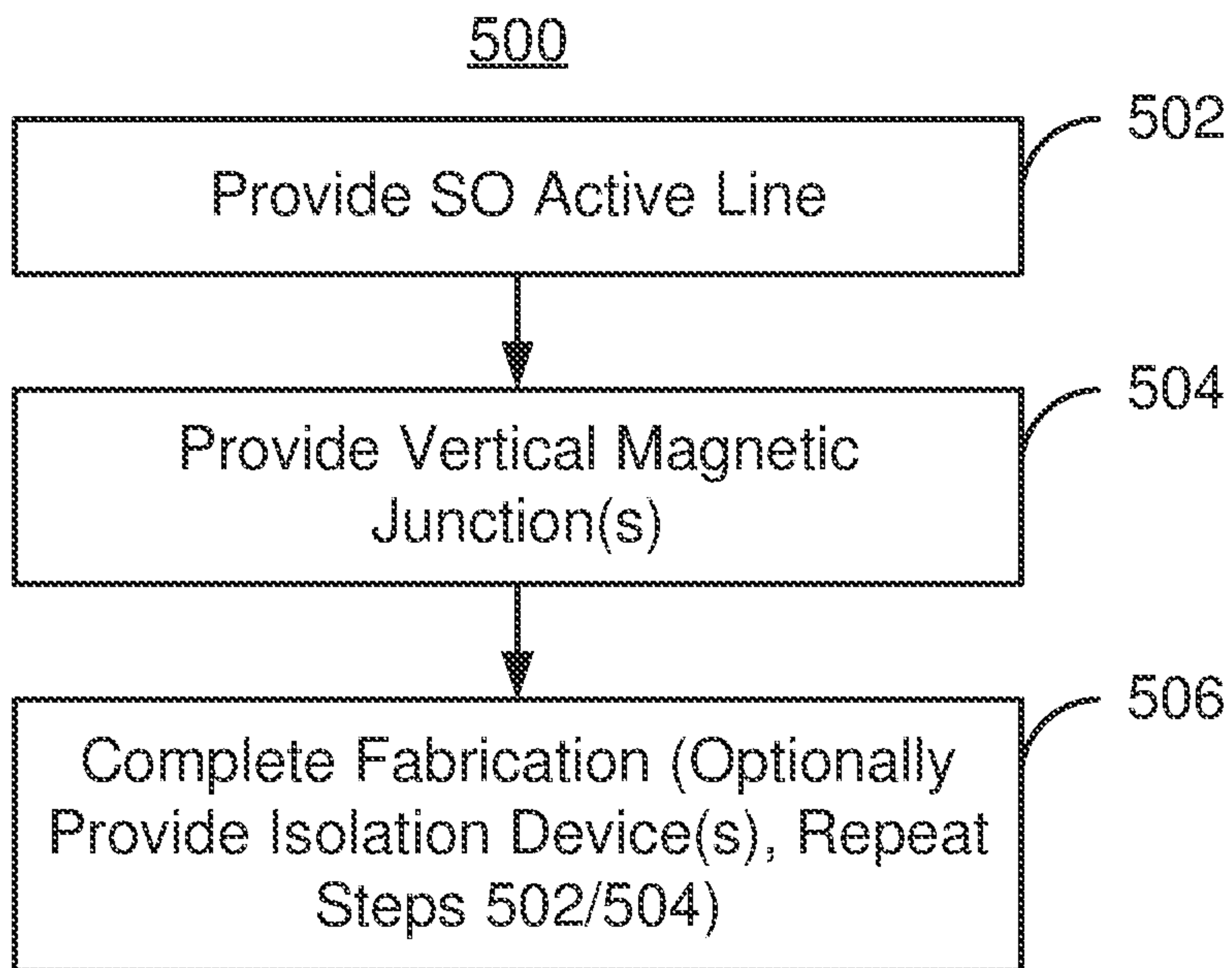

FIG. 17

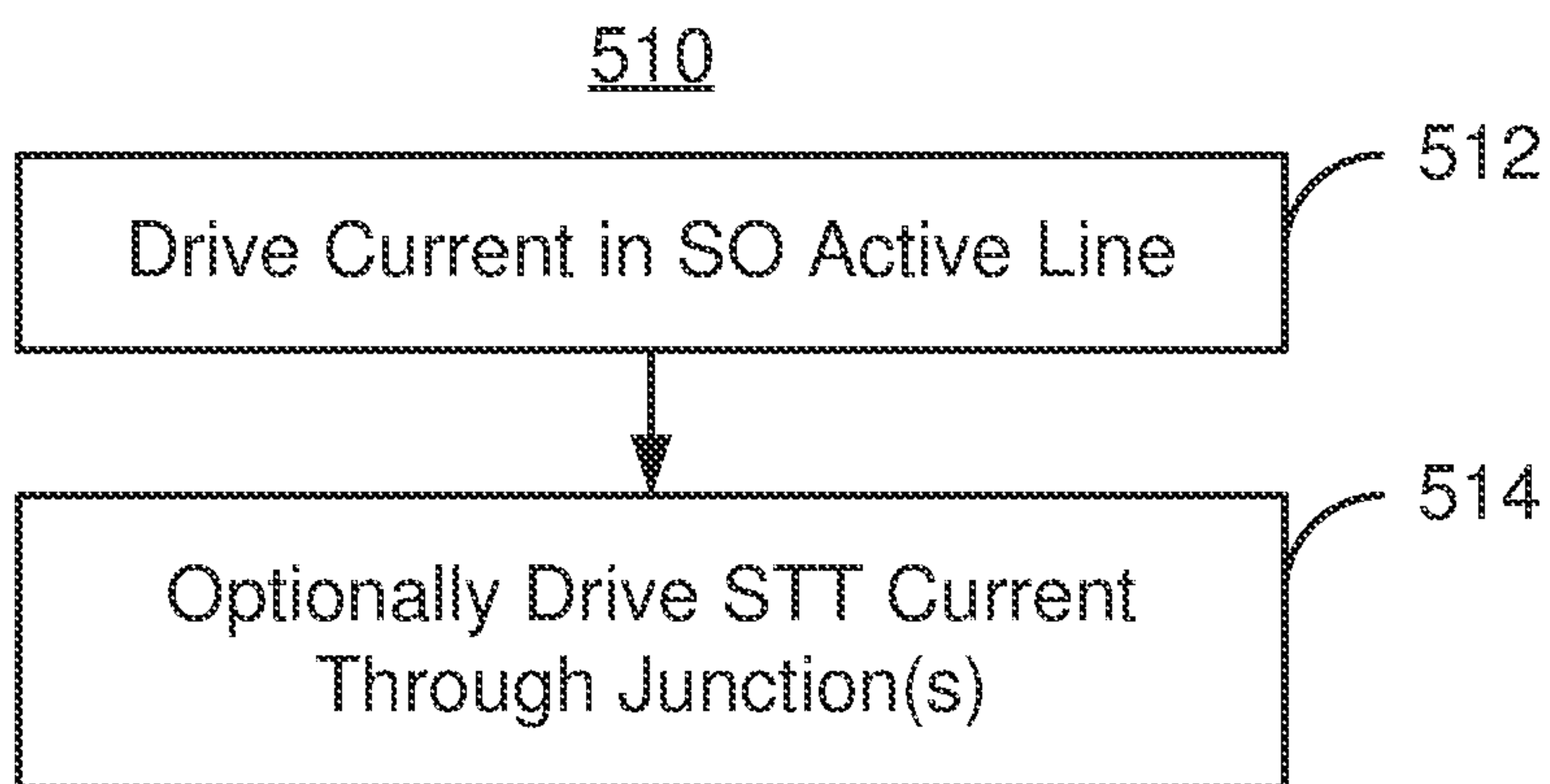

FIG. 18

VERTICAL SPIN ORBIT TORQUE DEVICES

Matter enclosed in heavy brackets [] appears in the original patent but forms no part of this reissue specification; matter printed in italics indicates the additions made by reissue; a claim printed with strikethrough indicates that the claim was canceled, disclaimed, or held invalid by a prior post-patent action or proceeding.

CROSS-REFERENCE TO RELATED APPLICATIONS

This [application] *reissue patent application Ser. No. 17/308,505 is a reissue of U.S. patent application Ser. No. 15/968,514, now U.S. Pat. No. 10,411,184, which* claims the benefit of provisional Patent Application Ser. No. 62/637,596, filed Mar. 2, 2018, entitled VERTICAL SPIN ORBIT TORQUE DEVICES INCLUDING MAGNETIC RANDOM ACCESS MEMORY, assigned to the assignee of the present application, [and] *the entire content of each of which are incorporated herein by reference.*

BACKGROUND OF THE INVENTION

Magnetic memories, particularly magnetic random-access memories (MRAMs), have drawn increasing interest due to their potential for high read/write speed, excellent endurance, non-volatility and low power consumption during operation. An MRAM can store information utilizing magnetic materials as an information recording medium. Some magnetic memories write to the magnetic material using a current. One such magnetic memory programs magnetic junctions using spin-orbit interaction (SO) torque.

SO torque-based memories, such as a SO torque magnetic random-access memory (SOT-MRAM), utilize conventional magnetic tunneling junctions (MTJs) in conjunction with a line having a high spin-orbit interaction (hereinafter SO line). The conventional MTJ includes a pinned (or reference) layer, a free layer and a tunneling barrier layer between the pinned and free layers. The MTJ typically resides on a substrate and may include seed and capping layer(s) as well as an antiferromagnetic (AFM) layer. The reference layer and the free layer are magnetic. The magnetization of the reference layer is fixed, or pinned, in a particular direction. The free layer has a changeable magnetization. The reference layer and free layer may have their magnetizations oriented perpendicular to the plane of the layers (perpendicular-to-plane) or in the plane of the layers (in-plane). The SO line is adjacent to the free layer of the conventional MTJ. The high spin-orbit interaction may be due to a bulk effect of the material itself (spin Hall effect), due to interfacial interactions (Rashba effect), some other effect and/or some combination thereof.

In conventional SO memories, writing is performed by driving a current in-plane (CIP) through the SO line. If the free layer magnetic moment is stable in-plane, then the in-plane SO torque alone can switch the free layer between stable states. Thus, a current driven through the adjacent SO line generates an SO torque that may switch the direction of magnetization of the free layer without additional switching mechanism(s). In contrast, if the free layer has a magnetic moment that is stable perpendicular-to-plane, then an additional torque is used. Since the spin orbit torque is in-plane, in order to reliably switch the magnetic moment using the in-plane current, a symmetry breaking additional torque is required, and can be achieved by either modest external

magnetic field, an in-stack magnetic bias, or STT torque through MgO barrier. The in-plane current develops an SO torque, which can be used to rotate the free layer magnetic moment from vertical to near in-plane direction. Switching to the desired direction is completed using the external magnetic bias or STT current. For example, the external magnetic field, an additional AFM layer or biasing structure may magnetically bias the free layer to complete switching to the desired state.

Although the conventional magnetic junction may be written using spin transfer and used in a spin transfer torque random access memory (STT-RAM), there are drawbacks. In general, SO torque is not an efficient mechanism for switching the free layer. Stated differently, the SO angle (measure of this efficiency of SO torque) is generally small. Thus, a high write current may be required for writing. In addition, the spin current in regions not adjacent to the magnetic is not used in writing. Thus, this spin current may be wasted. Memory cells using SO torque may have a large footprint because a three-terminal device may be used for write and read operations. Perpendicular magnetic moments in the layers of the magnetic junction may also not be usable in some embodiments. Thus, scalability may be limited. Consequently, a mechanism for improving SO torque magnetic devices is still desired.

BRIEF SUMMARY OF THE INVENTION

A magnetic device and method for programming the magnetic device are described. The magnetic device includes a plurality of magnetic junctions and at least one spin-orbit interaction (SO) active layer having a plurality of sides *and an axis*. The SO active layer(s) carry a current in direction(s) substantially [perpendicular to the plurality of sides] *along the axis*. Each of the magnetic junction(s) is adjacent to the sides and substantially surrounds a portion of the SO active layer. Each magnetic junction includes a free layer, a reference layer and a nonmagnetic spacer layer between the pinned and free layers. The SO active layer(s) exert a SO torque on the free layer due to the current passing through the SO active layer(s). The free layer is switchable between stable magnetic states. The free layer may be written using the current and, in some aspects, another current driven through the magnetic junction.

Performance of magnetic devices using magnetic junctions written using SO torque may be improved. For example, the interface for the spin current may be enhanced, the design may be scalable, fewer selection devices might be used, switching time might be reduced, read and write may be separately optimized, and/or breakdown of a tunneling barrier used in some aspects may be reduced.

BRIEF DESCRIPTION OF SEVERAL VIEWS OF THE DRAWINGS

FIGS. 1A-1C depict perspective, cross-section and top views of an exemplary embodiment of a magnetic device including vertical magnetic junctions programmable using SO torque.

FIGS. 2A-2C depict exemplary embodiments of the magnetic moment of a vertical magnetic junction.

FIGS. 3A-3B depict exemplary embodiments the magnetic moment of a free layer after switching using SO torque.

FIG. 4 depicts a top view of another exemplary embodiment of a magnetic device including vertical magnetic junctions programmable using SO torque.

FIG. 5 depicts a top view of another exemplary embodiment of a magnetic device including vertical magnetic junctions programmable using SO torque.

FIG. 6 depicts a top view of another exemplary embodiment of a magnetic device including vertical magnetic junctions programmable using SO torque.

FIGS. 7A-7B depict perspective and top views of an exemplary embodiment of a magnetic device including vertical magnetic junctions programmable using SO torque.

FIGS. 8A-8C depict perspective, cross-section and top views of an exemplary embodiment of a magnetic device including vertical magnetic junctions programmable using SO torque.

FIGS. 9A-9F depict cross-sectional views of an exemplary embodiment of a magnetic device including vertical magnetic junctions programmable using SO torque during writing and reading.

FIG. 10 depicts a perspective view of another exemplary embodiment of a magnetic memory including vertical magnetic junctions programmable using SO torque.

FIG. 11 depicts a perspective view of another exemplary embodiment of a magnetic memory including vertical magnetic junctions programmable using SO torque.

FIG. 12 depicts a perspective view of another exemplary embodiment of a magnetic memory including vertical magnetic junctions programmable using SO torque.

FIG. 13 depicts a circuit diagram of another exemplary embodiment of a magnetic memory including vertical magnetic junctions programmable using SO torque.

FIG. 14 depicts a circuit diagram of another exemplary embodiment of a magnetic memory including vertical magnetic junctions programmable using SO torque.

FIG. 15 depicts a perspective view of another exemplary embodiment of a magnetic device including multiple vertical magnetic junctions programmable using SO torque.

FIG. 16 depicts a perspective view of another exemplary embodiment of a magnetic device including multiple vertical magnetic junctions programmable using SO torque.

FIG. 17 is a flow chart depicting an exemplary embodiment of a method for providing a magnetic device programmable using SO torque in and including vertical magnetic junctions.

FIG. 18 is a flow chart depicting an exemplary embodiment of a method for programming a magnetic junction programmable using SO torque and including vertical magnetic junctions.

DETAILED DESCRIPTION OF THE INVENTION

The exemplary embodiments relate to magnetic junctions usable in magnetic devices, such as magnetic memories and/or logic devices, and the devices using such magnetic junctions. The magnetic memories may include magnetic random-access memories (MRAMs) and may be used in electronic devices employing nonvolatile memory. Such electronic devices include but are not limited to cellular phones, smart phones, tables, laptops and other portable and non-portable computing devices. The following description is presented to enable one of ordinary skill in the art to make and use the invention and is provided in the context of a patent application and its requirements. Various modifications to the exemplary embodiments and the generic principles and features described herein will be readily apparent. The exemplary embodiments are mainly described in terms of particular methods and systems provided in particular implementations. However, the methods and systems will

operate effectively in other implementations. Phrases such as “exemplary embodiment”, “one embodiment” and “another embodiment” may refer to the same or different embodiments as well as to multiple embodiments. The embodiments will be described with respect to systems and/or devices having certain components. However, the systems and/or devices may include more or less components than those shown, and variations in the arrangement and type of the components may be made without departing from the scope of the invention. The exemplary embodiments will also be described in the context of particular methods having certain steps. However, the method and system operate effectively for other methods having different and/or additional steps, substeps and/or steps in different orders that are not inconsistent with the exemplary embodiments. Thus, the present invention is not intended to be limited to the embodiments shown but is to be accorded the widest scope consistent with the principles and features described herein.

The exemplary embodiments are described in the context of particular methods, magnetic junctions and magnetic memories having certain components. One of ordinary skill in the art will readily recognize that the present invention is consistent with the use of magnetic junctions and magnetic memories having other and/or additional components and/or other features not inconsistent with the present invention. The method and system are also described in the context of current understanding of the spin orbit interaction phenomenon, magnetic anisotropy, and other physical phenomenon. Consequently, one of ordinary skill in the art will readily recognize that theoretical explanations of the behavior of the method and system are made based upon this current understanding of spin transfer, magnetic anisotropy and other physical phenomena. However, the method and system described herein are not dependent upon a particular physical explanation. One of ordinary skill in the art will also readily recognize that the method and system are described in the context of a structure having a particular relationship to the substrate. However, one of ordinary skill in the art will readily recognize that the method and system are consistent with other structures. In addition, the method and system are described in the context of certain layers being synthetic and/or simple. However, one of ordinary skill in the art will readily recognize that the layers could have another structure. Furthermore, the method and system are described in the context of magnetic junctions having particular layers. However, one of ordinary skill in the art will readily recognize that magnetic junctions having additional and/or different layers not inconsistent with the method and system could also be used. Moreover, certain components are described as being magnetic, ferromagnetic, and ferrimagnetic. As used herein, the term magnetic could include ferromagnetic, ferrimagnetic or like structures. As used herein, “in-plane” is substantially within or parallel to the plane of one or more of the layers of a magnetic junction. Conversely, “perpendicular” and “perpendicular-to-plane” corresponds to a direction that is substantially perpendicular to one or more of the layers of the magnetic junction.

The use of the terms “a” and “an” and “the” and similar referents in the context of describing the invention (especially in the context of the following claims) are to be construed to cover both the singular and the plural, unless otherwise indicated herein or clearly contradicted by context. The terms “comprising,” “having,” “including,” and “containing” are to be construed as open-ended terms (i.e., meaning “including, but not limited to,”) unless otherwise noted.

Unless defined otherwise, all technical and scientific terms used herein have the same meaning as commonly understood by one of ordinary skill in the art to which this invention belongs. It is noted that the use of any and all examples, or exemplary terms provided herein is intended merely to better illuminate the invention and is not a limitation on the scope of the invention unless otherwise specified. Further, unless defined otherwise, all terms defined in generally used dictionaries may not be overly interpreted.

A magnetic device and method for programming the magnetic device are described. The magnetic device includes a plurality of magnetic junctions and at least one spin-orbit interaction (SO) active layer having a plurality of sides *and an axis*. The SO active layer(s) carry a current in direction(s) substantially [perpendicular to the plurality of sides] *along the axis*. Each of the magnetic junction(s) is adjacent to the sides and substantially surrounds a portion of the SO active layer. Each magnetic junction includes a free layer, a reference layer and a nonmagnetic spacer layer between the pinned and free layers. The SO active layer(s) exert a SO torque on the free layer due to the current passing through the SO active layer(s). The free layer is switchable between stable magnetic states. The free layer may be written using the current and, in some aspects, another current driven through the magnetic junction.

FIGS. 1A-1C depict perspective, cross-section and top views of an exemplary embodiment of a magnetic device **100** including a vertical magnetic junction **110** programmable using SO torque. For clarity, FIGS. 1A-1C are not to scale. In addition, portions of the magnetic device **100** such as bit lines, row and column selectors are not shown. The magnetic device **100** includes magnetic junctions **110** and a spin-orbit interaction (SO) active layer **130** analogous to the SO line described above. In some embodiments, selection devices (not shown) and other components may also be included. Not shown is an optional insertion layer that may be between the SO active layer **130** and the magnetic junction **110**. Typically, multiple magnetic junctions **110** and multiple SO active layer **130** may be included in the magnetic device **100**. The magnetic device **100** may be used in a variety of electronic devices.

The magnetic junction **110** includes a free layer **112**, a nonmagnetic spacer layer **114** and a reference layer **116**. The magnetic junction **110** may also include optional polarization enhancement layer(s) (PEL(s)) having a high spin polarization. For example, a PEL might include Fe, CoFe and/or CoFeB. The PEL may be between the reference layer **116** and the nonmagnetic spacer layer **114** and/or between the nonmagnetic spacer layer **114** and the free layer. Contact, optional seed layer(s) and optional capping layer(s) may be present but are not shown for simplicity. An optional pinning layer (not shown) may be used to fix the magnetization (not shown) of the reference layer **116**. The optional pinning layer may be an AFM layer or multilayer that pins the magnetization (not shown) of the reference layer **116** by an exchange-bias interaction. However, in other embodiments, the optional pinning layer may be omitted or another structure may be used. In other embodiments, discussed below, the reference layer **116** and nonmagnetic spacer layer **114** might be omitted.

Also not shown in FIGS. 1A-1C is the underlying substrate on which the components **110** and **130** are grown. In some embodiments, the substrate is in the x-y plane. In such an embodiment, the z direction is perpendicular to the plane and vertical. In such embodiments, the magnetic junction **110** has the plane of its layers **112**, **114** and **116** perpendicu-

lar to the plane of the substrate. Stated differently, the interfaces between the layers **112**, **114** and **116** would be at a nonzero angle from the substrate surface (not shown). In the embodiment shown, if the substrate is in the x-y plane, the interfaces are substantially perpendicular to the substrate. Consequently, the magnetic junction **110** may be considered to be a vertical magnetic junction. In other embodiments, the interfaces between the layers **112**, **114** and **116** may be tilted with respect to the substrate. For example, if the magnetic junction **110** is conical in profile instead of cylindrical or if the magnetic junction is cylindrical but has an axis that is not parallel to the z-axis. In other embodiments, the substrate oriented in another manner. For example, the substrate might be in the x-z plane or the y-z plane. In such embodiments, the axis of the SO active layer **130** is horizontal. In such embodiments, a portion of the magnetic junction **110** lies below the SO active layer **130**. However, such embodiments may be difficult to fabricate.

The reference layer **116** is magnetic and may be a multilayer. For example, the reference layer **116** may be a synthetic antiferromagnet (SAF) including multiple ferromagnetic layers interleaved with and sandwiching nonmagnetic layer(s) such as Ru. Other multilayers may be used in the reference layer **116**. For example, the reference layer **116** may include or consist of one or more of CoFe, CoFeB, FeB, and/or CoPt. Note that as used herein CoFeB, FeB, CoB, CoPt and other materials listed denote alloys in which the stoichiometry is not indicated. For example, CoFeB may include $(\text{CoFe})_{1-x}\text{B}_x$, where x is greater than or equal to zero and less than or equal to 0.5 as-deposited. For example, x may be at least 0.2 and not more than 0.4. Other materials and/or structures are possible for the reference layer **116**. The magnetic moment of the reference layer **116** may take on various configurations that are discussed below.

The nonmagnetic NM spacer layer **114** is between reference layer **116** and the free layer **112**. The nonmagnetic spacer layer **114** may be a tunneling barrier layer. For example, the nonmagnetic spacer layer **114** may include or consist of MgO, aluminum oxide and/or titanium oxide. The MgO layer may be crystalline and have a 200 orientation for enhanced tunneling magnetoresistance (TMR). In other embodiments, the nonmagnetic spacer layer **114** may be a different tunneling barrier layer, may be a conductive layer or may have another structure.

The free layer **112** is magnetic and may be a multilayer. The free layer **112** may be a SAF or other multilayer. For example, the free layer **112** may include or consist of one or more of CoFe, CoFeB and/or Fe. The magnetic moment of the free layer **112** may have various stable states that are discussed below. The free layer is adjacent to the sides of the SO active layer **130**. In the embodiment shown, the sides of the SO active layer **130** are cylindrical and perpendicular to the x-y plane. The free layer **112** is substantially perpendicular to the x-y plane and cylindrical. In the embodiment shown in FIGS. 1A-1C, the free layer **112** adjoins, or shares an interface with, at least a portion of the sides of the SO active layer **130**. In another embodiment, a thin layer may be inserted between the free layer **112** and the SO active layer **130**. For example, such a layer may moderate/enhance SO torque. Although shown in FIGS. 1A-1C as completely surrounding the sides of the SO active layer **130** that are adjacent to the magnetic junction **110**, in other embodiments the free layer **112** may not completely enclose the SO active layer **130**. For example, there may be a section missing from the magnetic junction **110** shown in FIGS. 1A-1C. In some embodiments, for example, not more than half of the magnetic junction on one side of the SO active layer **130** may be

omitted. However, a magnetic junction **110** that completely surrounds a portion of the sides of the SO active layer **130** is generally desired.

The magnetic junction **110** is configured such that the free layer **112** is switchable between stable magnetic states using a write current which is passed through the SO active layer **130** along the axis of the SO active layer **130** (e.g. along the z axis/ $\pm z$ direction in FIGS. 1A-1C). Thus, the free layer **112** is programmable using SO torque. In some embodiments, the free layer **112** is programmable in the absence of a write current driven through the magnetic junction **110**. Stated differently, spin transfer torque (STT) is not needed to write to the magnetic junction **110** in some embodiments. In alternate embodiments, however, a modest current driven through the magnetic junction **110** and/or an external magnetic field/magnetic bias may be used to assist in switching the free layer magnetic moment.

The SO active layer **130** is a layer that has a strong spin-orbit interaction and is used in switching the magnetic moment (not shown) of the free layer **112**. For example, the SO active layer may include or consist of materials having a large SO angle with large spin-orbit coupling such as one or more of T, W, IrMn, or Pt, or a topological insulator, such as BiTe, BiSe, BiSb, and/or SbTe. Although termed a "layer", in the embodiment shown in FIGS. 1A-1C, the current carrying line **130** consists of the SO active material. Thus, when used in connection with the SO materials, the term layer need not imply a particular shape or orientation to the substrate. For example, the SO active layer **130** need not be a thin, rectangular or planar. Although the line **130** consists of the SO active layer **130** in FIGS. 1A-1C, in other embodiments, the line **130** may include other materials. For example, a higher conductivity material may replace or supplement the SO active layer **130** in regions distal from the magnetic junction **110**. In other embodiments, a higher resistivity/lower conductivity core might be used. A write current is driven along the length of the SO active layer **130** in the $+z$ direction or the $-z$ direction. This write current gives rise to an attendant SO interaction, which results in a spin-orbit torque used in writing to the free layer **112**.

As discussed above, the stable magnetic states of the free layer **112**, as well as the reference layer **116**, may take on various configurations. FIGS. 2A-2C depict exemplary embodiments of magnetic devices **100** and the magnetic moment of vertical magnetic junction **110A**, **110B** and **110C**. The magnetic junctions **110A**, **110B** and **110C** are analogous to the magnetic junction **110**. The magnetic junction **110A** includes free layer **112A**, nonmagnetic spacer layer **114** and reference layer **116A** that are analogous to the free layer **112**, nonmagnetic spacer layer **114** and reference layer **116**, respectively. Consequently, the structure, function and materials used in the layers **112A**, **114** and **116A** are analogous to those for the layers **112**, **114** and **116**. However, the magnetic moments **113A** and **117A** of the free layer **112A** and reference layer **116A**, respectively, are explicitly shown. The reference layer magnetic moment **117A** is along the z-axis. The free layer stable states are along the $+z$ -direction and the $-z$ -direction. Stated differently, the free layer **112** has its easy axis parallel to the z-axis shown in FIG. 1A. The magnetic device **100A** may have improved scalability, may have fast switching (e.g. less than 0.5 nanoseconds) and may be thermally stable, but may require large current densities for switching in some embodiments.

The magnetic junction **110B** includes free layer **112B**, nonmagnetic spacer layer **114** and reference layer **116B** that are analogous to the free layer **112**, nonmagnetic spacer layer **114** and reference layer **116**, respectively.

Consequently, the structure, function and materials used in the layers **112B**, **114** and **116B** are analogous to those for the layers **112**, **114** and **116**. However, the magnetic moments **113B** and **117B** of the free layer **112B** and reference layer **116B**, respectively, are explicitly shown. The reference layer magnetic moment **117B** circulates around the z-axis and, therefore, around the SO active layer **130**. The free layer stable states also circulate around the z-axis. The magnetic device **100B** may have improved scalability, may use lower current densities for switching (e.g. less than 3 MA/cm²) and may be thermally stable, but may require larger switching times (e.g. greater than 10 nanoseconds).

The magnetic junction **110C** includes free layer **112C**, nonmagnetic spacer layer **114** and reference layer **116C** that are analogous to the free layer **112**, nonmagnetic spacer layer **114** and reference layer **116**, respectively. Consequently, the structure, function and materials used in the layers **112C**, **114** and **116C** are analogous to those for the layers **112**, **114** and **116**. However, the magnetic moments **113C** and **117C** of the free layer **112C** and reference layer **116C**, respectively, are explicitly shown. The reference layer magnetic moment **117C** is radial. In the embodiment shown, the moment **117C** is toward the z-axis. In another embodiment, the moment **117C** might be radial away from the z-axis. Similarly, the free layer stable states are also radial. The magnetic device **100C** may deliver intermediate performance. For example, the magnetic device **100C** have improved scalability, may use interfacial perpendicular magnetic anisotropy (I-PMA) for improved thermal stability, may use intermediate current densities (e.g. greater than 20 MA/cm²) and may have somewhat smaller switching times (e.g. <1 nanosecond), but may be less thermally stable.

Thus, three particular configurations of magnetic moments are shown in magnetic junctions **110A**, **110B** and **110C**. In another embodiment, other configurations might be used.

Referring back to FIGS. 1A-1C, the magnetic junction **110** may be read in a conventional manner. Thus, a read current insufficient to program the magnetic junction **110** using STT may be driven through the magnetic junction **110** in the direction perpendicular to at least some of the interfaces between the layers **112**, **114** and **116**. In the embodiment shown, the current may be driven radially (perpendicular to the z-axis) or in another direction such as along the y axis or along the x-axis. The resistance of the magnetic junction **110** is based on the orientation between the free layer magnetic moment and the reference layer magnetic moment. Thus, data may be read from the magnetic junction **110** by determining the resistance of the magnetic junction **110**. The magnetic junctions **110A**, **110B** and **110C** may be read in an analogous manner.

In programming the magnetic junction **110**, however, a write current is driven through the SO active layer **130** and substantially [perpendicular to the sides of the SO active layer **130** adjacent to the free layer **112**. In the embodiment shown, this is] along the z axis. Based on the direction of current, spins polarized in opposite directions may drift to opposing sides of the SO active layer **130**. Because the free layer **112** and magnetic junction **110** substantially surround the sides of the SO active layer **130**, all of these polarized spins may be used in writing to the free layer **112**. In some embodiments, the stable magnetic states of the free layer **112** are configured such that the SO torque due to these spins can switch the magnetic state of the free layer **112**.

For example, FIGS. 3A-3B depict exemplary embodiments of the magnetic moment of a free layer in the

magnetic junction **110B** after switching using SO torque. As discussed above, the free layer **112B** has stable states circulating around the z-axis (the SO active layer **130**). Thus, FIGS. **3A-3B** essentially depict the magnetic junction **110B** during writing if the magnetic moments circulate around the SO active layer **130**. FIG. **3A** depicts the magnetic device **100/100B** when the current is driven through the SO active layer **130** out of the plane of the page. Thus, current density J_{c+} is shown. Because of the SO effect, spins migrate to the sides of the SO active layer **130**, as shown. The spins on one side of the SO active layer **130** have opposite polarization to spins on the opposite side of the SO active layer **130**. These spins have exerted an SO torque on the free layer **112**, causing the free layer magnetic moment **113B'** to be in the direction shown.

In contrast, FIG. **3B** depicts the magnetic device **100/100B** when the current is driven through the SO active layer **130** into the plane of the page. Thus, current density J_{c-} is shown. Because of the SO effect, spins migrate to the sides of the SO active layer **130**, as shown. The spins on one side of the SO active layer **130** still have opposite polarization to spins on the opposite side of the SO active layer **130**. However, the orientations have flipped. These spins have exerted an SO torque on the free layer **112**, causing the free layer magnetic moment **113B''** to be in the direction shown. Thus, in the embodiment shown in FIGS. **3A** and **3B**, the free layer **112** may be programmed using only an SO current J_{c+}/J_{c-} through the SO active layer **130**. In other embodiments, the programming might be assisted by an additional current and/or a magnetic field. For example, an STT current may be driven through the magnetic junction **110B**. Such a mechanism for programming could be used with the magnetic junctions **110B**, **110C**, and/or **110D** having the stable states of the free layer magnetic moment circulating around the z-axis, oriented radially with respect to the z-axis or along the z-axis. In such embodiments, the STT current may be used to select a final direction of the magnetic moment. Thus, a more modest STT current may be used to switch the free layer **112** in such embodiments.

The magnetic devices **100**, **100A**, **100B** and **100C** may have improved performance. The free layer **112/112A/112B/112C** may be programmed using SO torque and a current driven through the SO active layer **130**. Because no STT write current is driven through the magnetic junction **110** for programming, damage to the magnetic junction **110** may be avoided. For example, breakdown of the tunneling barrier layer **114** may be circumvented. Even if an STT write current is driven through the magnetic junction **110/110A/110B/110C**, the magnitude of the current may be smaller. Thus, damage to the magnetic junction **110/110A/110B/110C** may be reduced or prevented. Moreover, the interface for the SO torque to act on the free layer **112/112A/112B/112C** may be enhanced. As such, a smaller write current may be driven through the SO active layer **130** while still writing to the magnetic junction **110/110A/110B/110C**. The configuration of the magnetic junction **110/110A/110B/110C** and SO active layer **130** may be more scalable and switching time reduced. Writing may be primarily achieved using a current through the SO active layer, while reading performed using a current through the magnetic junction. As a result, read and write may be separately optimized.

FIGS. **4-6** depict top views of other exemplary embodiment of magnetic devices **100D**, **100E** and **100F**, respectively, including vertical magnetic junctions **110D**, **110E** and **110F** programmable using SO torque and SO active layer **130D**, **130E** and **130F**. The magnetic junctions **110D**, **110E** and **110F** are analogous to the magnetic junctions **110**, **110A**,

110B and **110C**. The magnetic junction **110D** includes free layer **112D**, nonmagnetic spacer layer **114D** and reference layer **116D** that are analogous to the free layer **112**, nonmagnetic spacer layer **114** and reference layer **116**, respectively. Consequently, the structure, function and materials used in the layers **112D**, **114D** and **116D** are analogous to those for the layers **112**, **114** and **116**. Similarly, the SO active layer **130D** is analogous to the SO active layer **130**. Consequently, the structure, function and materials used in the SO active layer **130D** are analogous to those used in the SO active layer **130**. The magnetic junction **110D** and SO active layer **130D** are elliptical in footprint instead of circular. Thus, the magnetic device **100** is not limited to a circular footprint.

The magnetic junction **110E** includes free layer **112E**, nonmagnetic spacer layer **114E** and reference layer **116E** that are analogous to the free layer **112**, nonmagnetic spacer layer **114** and reference layer **116**, respectively. Consequently, the structure, function and materials used in the layers **112E**, **114E** and **116E** are analogous to those for the layers **112**, **114** and **116**. Similarly, the SO active layer **130E** is analogous to the SO active layer **130**. Consequently, the structure, function and materials used in the SO active layer **130E** are analogous to those used in the SO active layer **130**. The magnetic junction **110E** and SO active layer **130E** are square in footprint instead of circular. Thus, the magnetic device **100** is not limited to a circular footprint. In addition, an interlayer **118** is shown. This interlayer **118** resides between the SO active layer **130E** and the free layer **112E**. The layer **118** may be used to moderate (enhance and/or decrease) interaction between the free layer **112E** and the SO active layer **130E**. For example, the SO torque may be enhanced.

The magnetic junction **110F** includes free layer **112F**, nonmagnetic spacer layer **114F** and reference layer **116F** that are analogous to the free layer **112**, nonmagnetic spacer layer **114** and reference layer **116**, respectively. Consequently, the structure, function and materials used in the layers **112F**, **114F** and **116F** are analogous to those for the layers **112**, **114** and **116**. Similarly, the SO active layer **130F** is analogous to the SO active layer **130**. Consequently, the structure, function and materials used in the SO active layer **130F** are analogous to those used in the SO active layer **130**. The magnetic junction **110E** and SO active layer **130F** are rectangular in footprint instead of circular. In addition, the magnetic junction **110F** is shown as not completely surrounding the SO active layer **130F**. Instead, aperture or slot **119** is present. However, as discussed above, in generally, it is desirable for the magnetic junction to surround the SO active layer in order to increase the area available for interaction via SO torque.

FIGS. **7A-7B** depict perspective and top views of another exemplary embodiment of a magnetic device **100G** including vertical magnetic junction(s) **110G** programmable using SO torque. The magnetic junction **100G** is analogous to the magnetic junctions **110**, **110A**, **110B**, **110C**, **110D**, **110E** and **110F**. The magnetic junction **110E** includes free layer **112**, nonmagnetic spacer layer **114** and reference layer **116** that are analogous to the free layer **112**, nonmagnetic spacer layer **114** and reference layer **116**, respectively. Consequently, the structure, function and materials used in the layers **112**, **114** and **116** of the magnetic junction **110G** are analogous to those for the layers **112**, **114** and **116** of the magnetic junction(s) **110**, **110A**, **110B**, **110C**, **110D**, **110E** and **110F**. Similarly, the SO active layer **130E** is analogous to the SO active layer **130**. Consequently, the structure,

11

function and materials used in the SO active layer **130E** are analogous to those used in the SO active layer **130**.

However, the line **131** includes both the SO active layer **130G** and a core **132**. The core **132** may have a lower conductivity/higher resistivity than the SO active layer **130G**. For example, the core **132** may be formed of material (s) including but not limited to polysilicon, SiN and/or SiO.

The magnetic device **100G** may share the benefits of the magnetic devices **100**, **100A**, **100B**, **100C**, **100D**, **100E** and/or **100F**. In addition, the current may be preferentially carried through the SO active layer **130G**, closer to the interface with the free layer **112**. As a result, the SO active layer **130G** and the line **131** may have improved efficiency in delivering SO torque to the free layer **112**. Thus, performance of the magnetic device **100G** may be further improved.

FIGS. **8A-8C** depict perspective, cross-section and top views of an exemplary embodiment of a magnetic device **100H** including a vertical magnetic junction **110H** programmable using SO torque. For clarity, FIGS. **8A-8C** are not to scale. In addition, portions of the magnetic device **100H** such as bit lines, row and column selectors are not shown. The magnetic device **100H** includes magnetic junctions **110H** and a spin-orbit interaction (SO) active layer **130** analogous to the magnetic junction **110**, **110A**, **110B**, **110C**, **110D**, **110E**, **110F** and/or **110G** and SO active layer **130** and/or **130G** described above. In some embodiments, selection devices (not shown) and other components may also be included. Not shown is an optional interlayer, such as layer **118**, that may be between the SO active layer **130** and the magnetic junction **110H**. Typically, multiple magnetic junctions **110H** and multiple SO active layer **130** may be included in the magnetic device **100H**. The magnetic device **100H** may be used in a variety of electronic devices.

The magnetic junction **110H** includes a free layer **112** that is analogous to the free layer **112** of the magnetic junction **110**. Thus, the materials and configuration of the free layer **112** in the magnetic junction **110H** is analogous to that in the magnetic junction **110**. For example, the free layer **112** may be a SAF or other multilayer. The magnetic junction **110H** may also include optional PEL(s) having a high spin polarization. Contact, optional seed layer(s) and optional capping layer(s) may be present but are not shown for simplicity. Although the free layer **112** is shown as adjoining the SO active layer **130**, in other embodiments, a layer, such as interlayer **118**, may be inserted between the sides of the SO active layer **130** and the free layer **112**. Further, although shown as completely surrounding the sides of the SO active layer **130**, in other embodiments, the free layer **112** may include an aperture or may terminate without completely surrounding the SO active layer **130**.

Thus, the magnetic junction **100H** includes a free layer **112**. However, the nonmagnetic spacer layer **114** and a reference layer **116** of the magnetic junction **110** are omitted. Consequently, STT is not used in programming the free layer **112**. In some embodiments, an external magnetic field may be used in addition to SO torque to write to the free layer **112**. In addition, the magnetic junction **110H** is read using a current driven along the z-axis through the SO active layer **130** that is insufficient to program the free layer **112**.

For example, FIGS. **9A-9F** depict cross-sectional views of an exemplary embodiment of the magnetic device **100H** including vertical magnetic junctions programmable using SO torque during writing and reading. FIGS. **9A** and **9B** depict the magnetic junction **100H** just after having been programmed. FIG. **9A** depicts the magnetic device **110H** after a write current J_{c+} has been driven through the SO

12

active layer **130**. Thus, the free layer **112** has been written such that its magnetic moment **113H** is stable in the orientation shown. FIG. **9B** depicts the magnetic junction **110H** after write current J_{c-} has been driven through the SO active layer **130**. Thus, the free layer **112** has been written such that its magnetic moment **113H'** is stable in the opposite direction.

FIGS. **9C-9F** depict side views of the magnetic device **100H** during reading. The magnetic junction **100H** is read using currents having current densities J_+ and J_- driven along the z-axis through the SO active layer **130**. This current is insufficient to program the free layer **112**. The state of the free layer **112** is read using the difference in resistance due to the configurations of the spins in the SO active layer **130** and the magnetic moment of the free layer **112**. FIGS. **9C** and **9D** depict the magnetic device **100H** when the free layer magnetic moment circulates around the SO active layer **130** as shown (out of the plane of the page on one side of the layer **130** and into the plane of the page on the other). In FIG. **9C**, the current J_+ results in spins of opposite orientation migrating to opposite sides of the SO active layer, as shown. With the current J_+ , the spins align with the magnetic moment of the free layer **112** and result in a resistance of R_{1+} . As shown in FIG. **9D**, the spins in the SO active layer **130** are opposite to the magnetic moment of the free layer **112**. The resulting resistance is R_{1-} . In addition, $R_{1-} > R_{1+}$. Thus, a differential measurement results in a negative difference in resistance between J_+ and J_- .

FIGS. **9E** and **9F** depict a resistance measurement when the free layer **112** has a magnetic moment in the opposite direction. The current J_+ results in the spins migrating within the SO active layer **130** in the same manner as for FIG. **9C**. However, in this case, the spins are in the opposite direction as the free layer magnetic moment and result in a resistance of R_{2+} . For the current J_- , the spins migrate as shown in FIG. **9D**. However, the spins now align with the magnetic moment of the free layer **112** and result in a resistance R_{2-} . Further, $R_{2-} < R_{2+}$. Thus, a differential resistance measurement results in a positive difference in resistance between J_+ and J_- . Thus, the magnetic junction **100H** may be read and programmed using currents only through the SO active layer **130**.

Although specific magnetic devices **100**, **100A**, **100B**, **100C**, **100D**, **100E**, **100F**, **100G** and **100H** and particular magnetic junctions **110**, **110A**, **110B**, **110C**, **110D**, **110E**, **110F**, **110G** and **110H** have been described herein, one of ordinary skill in the art will recognize that one or more of the features described herein may be combined in manners not explicitly shown.

FIG. **10** is a perspective view of an exemplary embodiment of a memory **200A** that may use one or more of the magnetic devices **100**, **100A**, **100B**, **100C**, **100D**, **100E**, **100F**, **100G**, **100H** and/or other magnetic devices including a vertical magnetic junction written using SO torque. Only a portion of the magnetic memory **200A** is shown. For example, reading/writing column select drivers as well as word line select driver(s) are not shown. Note that other and/or different components may be provided.

The memory **200A** includes a substrate **202**, lines **201** and **203** and memory cells **210A**. Each memory cell **210A** includes a selection transistor **220A**, magnetic junction **212** and SO active layer **211**. Although only one magnetic junction **212** per cell is shown, in other embodiments, additional magnetic junctions may be used. The SO active layer **211** is analogous to the SO active layer **130** and/or **130G**/line **131**. The magnetic junctions **212** are analogous to the magnetic junction(s) **110**, **110A**, **110B**, **110C**, **110D**,

110E, 110F, 110G, 110H and/or another vertical magnetic junction. In addition, as can be seen by the orientation of the magnetic junctions 212 with respect to the substrate 202, the magnetic junctions 212 have interfaces (not shown) that may be substantially perpendicular to the substrate 202. The transistor 220A shown are planar transistors. In another embodiment, another selection device might be used. For example, an ovonic threshold selector (OTS) device might be used. In addition, also shown are lines 201 that may be used to drive current through the magnetic junction 212 for reading and/or writing. However, if a free layer only magnetic junction 100H is used, the lines 201 may be omitted. Because the magnetic memory 200A uses the magnetic junctions 212 and SO active layers 211, the magnetic memory 200A may enjoy the benefits described above.

FIG. 11 is a perspective view of an exemplary embodiment of a memory 200B that may use one or more of the magnetic devices 100, 100A, 100B, 100C, 100D, 100E, 100F, 100G, 100H and/or other magnetic devices including a vertical magnetic junction written using SO torque. Only a portion of the magnetic memory 200B is shown. For example, reading/writing column select drivers as well as word line select driver(s) are not shown. Note that other and/or different components may be provided.

The memory 200B includes a substrate 202, lines 201 and 203 and memory cells 210B. Each memory cell 210B includes a selection transistor 220B, magnetic junction 212 and SO active layer 211. Although only one magnetic junction 212 per cell is shown, in other embodiments, additional magnetic junctions may be used. The SO active layer 211 is analogous to the SO active layer 130 and/or 130G/line 131. The magnetic junctions 212 are analogous to the magnetic junction(s) 110, 110A, 110B, 110C, 110D, 110E, 110F, 110G, 110H and/or another vertical magnetic junction. In addition, as can be seen by the orientation of the magnetic junctions 212 with respect to the substrate 202, the magnetic junctions 212 have interfaces (not shown) that may be substantially perpendicular to the substrate 202. The transistor 220B shown are planar transistors. In another embodiment, another selection device including but not limited to an OTS selection device might be used. Also shown are lines 201 that may be used to drive current through the magnetic junction 212 for reading and/or writing. However, if a free layer only magnetic junction 100H is used, the lines 201 may be omitted.

Also shown in FIG. 11 is additional selector 230B. The selector 230B may be an OTS selector or other analogous device. Because the magnetic memory 200B uses the magnetic junctions 212 and SO active layers 211, the magnetic memory 200B may enjoy the benefits described above. In addition, use of two selection devices 220B and 230B may reduce or eliminate the sneak path for current. As such, performance may be further improved.

FIG. 12 is a perspective view of an exemplary embodiment of a memory 200C that may use one or more of the magnetic devices 100, 100A, 100B, 100C, 100D, 100E, 100F, 100G, 100H and/or other magnetic devices including a vertical magnetic junction written using SO torque. Only a portion of the magnetic memory 200C is shown. For example, reading/writing column select drivers as well as word line select driver(s) are not shown. Note that other and/or different components may be provided.

The memory 200C includes a substrate 202, lines 201 and 203 and memory cells 210C. Each memory cell 210C includes a selection transistor 220C, magnetic junction 212 and SO active layer 211. An optional second selection device 230C is also shown. Although only one magnetic junction

212 per cell is shown, in other embodiments, additional magnetic junctions may be used. The SO active layer 211 is analogous to the SO active layer 130 and/or 130G/line 131. The magnetic junctions 212 are analogous to the magnetic junction(s) 110, 110A, 110B, 110C, 110D, 110E, 110F, 110G, 110H and/or another vertical magnetic junction. In addition, as can be seen by the orientation of the magnetic junctions 212 with respect to the substrate 202, the magnetic junctions 212 have interfaces (not shown) that may be substantially perpendicular to the substrate 202. Also shown are lines 201 that may be used to drive current through the magnetic junction 212 for reading and/or writing. However, if a free layer only magnetic junction 100H is used, the lines 201 may be omitted. The transistor 220C shown are vertical (three-dimensional) transistors instead of planar transistors.

Because the magnetic memory 200C uses the magnetic junctions 212 and SO active layers 211, the magnetic memory 200C may enjoy the benefits described above. In addition, if two selection devices 220C and 230C are used, the sneak path for current may be reduced or eliminated. As such, performance may be further improved. Further, the magnetic memory 200C may be more scalable because of the use of three dimensional transistors 220C. Thus, the magnetic memory 200C may have enhanced performance.

FIG. 13 depicts an exemplary embodiment of a schematic for a memory 300A that may use one or more of the magnetic devices 100, 100A, 100B, 100C, 100D, 100E, 100F, 100G, 100H and/or other magnetic devices including vertical magnetic junctions programmable using SO torque. Only a portion of the magnetic memory 300A is shown. For example, reading/writing column select drivers as well as word line select driver(s) are not shown. Note that other and/or different components may be provided.

The magnetic memory 300A includes word lines 301, Vcc/Vdd/ground/read voltage lines 303, Vcc/Vdd/ground/floating lines 305, output lines 307 that may connect to a sense amplifier, magnetic junctions 312, SO active layers 311, selection transistor 320 and optional additional selection device 330A. The components 311, 312, 320 and (optionally) 330A form cells 310A. For simplicity only one cell is labeled. Each magnetic junction 312 is shown as connected to line 307. However, if a free layer only magnetic junction 100H is used this connection may be omitted.

Because the magnetic memory 300A uses the magnetic junctions 312 and SO active layers 311, the magnetic memory 300A may enjoy the benefits described above. In addition, if two selection devices 320 and 330A are used, the sneak path for current may be reduced or eliminated. As such, performance may be further improved. If the transistor 320 is a vertical transistor such as the transistor 220C, the magnetic memory 300A may be more scalable. Thus, the magnetic memory 300A may exhibit improved performance.

FIG. 14 depicts an exemplary embodiment of a schematic for a memory 300B that may use one or more of the magnetic devices 100, 100A, 100B, 100C, 100D, 100E, 100F, 100G, 100H and/or other magnetic devices including vertical magnetic junctions programmable using SO torque. Only a portion of the magnetic memory 300B is shown. For example, reading/writing column select drivers as well as word line select driver(s) are not shown. Note that other and/or different components may be provided.

The magnetic memory 300B is analogous to the magnetic memory 300A. Consequently, the magnetic memory 300B includes word lines 301, Vcc/Vdd/ground/read voltage lines 303, Vcc/Vdd/ground/floating lines 305, output lines 307 that may connect to a sense amplifier, magnetic junctions 312, SO active layers 311 and selection transistor 320 that

are analogous to components **301**, **303**, **305**, **307**, **312**, **311** and **320**, respectively. The components **311**, **312**, **320** and (optionally) **332B** form cells **310B**. For simplicity only one cell is labeled. Each magnetic junction **312** is shown as connected to line **307**. However, if a free layer only magnetic junction **100H** is used this connection may be omitted.

Each memory cell **310B** may include an optional diode **332B**. The diode **332B** may be used to eliminate the sneak path. In lieu of a diode **332B**, another configuration that functions as a diode may be used.

Because the magnetic memory **300B** uses the magnetic junctions **312** and SO active layers **311**, the magnetic memory **300B** may enjoy the benefits described above. In addition, if the diodes **332B** are used, the sneak path for current may be reduced or eliminated. As such, performance may be further improved. If the transistor **320** is a vertical transistor such as the transistor **220C**, the magnetic memory **300B** may be more scalable. Thus, the magnetic memory **300B** may exhibit improved performance.

FIGS. **15-16** depict perspective views of other exemplary embodiments of a magnetic devices **400A** and **400B** including multiple vertical magnetic junctions **412** programmable using SO torque. The magnetic junctions **412** are analogous to the magnetic junction(s) **110**, **110A**, **110B**, **110C**, **110D**, **110E**, **110F**, **110G**, **110H** and/or another vertical magnetic junction. Also shown are SO active layers **411** analogous to the SO active layers **130** and/or **130G**/line **131**. For simplicity, not all SO active layers **411** are labeled in FIG. **15**. Although a particular number of magnetic junctions are shown in each magnetic device **400A** and **400B**, in other embodiments, other number(s) may be used. In the magnetic device **400B**, isolation devices **414** are shown as interleaved between the magnetic junction **412**. For example, the isolation devices **414** might be vertical transistors analogous to the transistor **220C**. The magnetic devices **400A** and/or **400B** might be incorporated into a device utilizing the magnetic devices **100**, **100A**, **100B**, **100C**, **100D**, **100E**, **100F**, **100G**, **100H** and/or an analogous device. For example, one or more of the magnetic memories **200A**, **200B**, **200C**, **300A** and/or **300B** might use the magnetic device **400A** and/or **400B**.

In some embodiments, the magnetic junctions **412** may be individually programmed using a combination of current driven through the SO active layers **411** (i.e. using SO torque) and a current driven through the magnetic junction (e.g. STT torque). Such embodiments include those in which the SO torque is collinear with the magnetization, such as the magnetic junction **1008**. For example, a write current that is insufficient to write to the magnetic junction **412** alone may be driven through the SO active layer **411**. Each magnetic junction **412** to be written may simultaneously have an STT current driven through it. For example, the STT current may be radial or simply in a particular direction that allows the STT current to pass through the interface(s) between the layers of the magnetic junction **412**. The combination of the currents driven in the appropriate directions writes to the desired magnetic junctions **412**. In some embodiments, an STT current driven in one direction through the magnetic junctions **412** to be switched aids in programming, while an STT current driven in the opposite direction through magnetic junctions **412** not to be switched prevents writing to such magnetic junctions from being programmed. In other embodiments, a current is driven through the SO active layer **411**. A small STT current may be driven through the magnetic junctions **412** desired to be written, for example to select the final direction of magnetization after programming. In some embodiments, the mag-

netic moment of the free layer of each magnetic junction **412** may be stable radially, in a manner analogous to the magnetic junction **100C**. A current driven through the SO active layer may destabilize the magnetic moments such that the free layer magnetic moments circulate around the SO active layer **411**. The final direction of magnetization may be set by applying a small STT current to the magnetic junction(s) **412** desired to be programmed. When the currents are removed, the magnetic junctions **412** are programmed in the desired radial direction. In another embodiment, the magnetic moment of the free layer of each magnetic junction **412** is stable axially (along the axis of the cylinder shown in FIGS. **15** and **16**) in a manner analogous to the magnetic junction **100A**. In such an embodiment, a current driven through the SO active layer may still destabilize the magnetic moments such that the free layer magnetic moments circulate around the SO active layer **411**. The final direction of magnetization may be set by applying a small STT current to the magnetic junction(s) **412** desired to be programmed. This STT torque has an axial direction due to the magnetic moment of the reference layer. When the currents are removed, the magnetic junctions **412** are programmed in the desired axial direction.

FIG. **17** depicts an exemplary embodiment of a method **500** for fabricating a magnetic device programmable using SO torque and including vertical magnetic junctions. For simplicity, some steps may be omitted, performed in another order, include substeps and/or combined. Further, the method **500** may start after other steps in forming a magnetic memory have been performed. For simplicity, the method **500** is described in the context of the magnetic device **100**. However, other magnetic devices, including but not limited to the magnetic devices **100A**, **100B**, **100C**, **100D**, **100E**, **100F**, **100G** and/or **100H** may be formed.

At least one SO active layer **130** is provided, via step **502**. Step **502** may include depositing and patterning the desired materials for each SO active layer **130**. In some embodiments, step **502** includes forming the low conductivity core **132** and the SO active layer **130G** on the core **132**. Thus, a pillar may be formed in step **502**. The interlay layer **118** may optionally be provided as part of step **502**.

The magnetic junctions **110** may then be formed, via step **504**. Step **504** may include blanket depositing the layers for the free layer **112**, nonmagnetic spacer layer **114**, reference layer **116** and any additional layers desired in the magnetic junction **110**. Alternatively, the nonmagnetic spacer layer **114** and/or reference layer **114** might be omitted. Anneal(s) and/or other processing steps may also be performed. The magnetic junctions **110** may then be defined. For example, a planarization step may remove the portions of the magnetic junctions **110** connection layer **112**, **114** and **116** and the SO active layer **130** physically exposed.

Fabrication may then be completed, via step **506**. For example, isolation and/or selection devices may be formed. If magnetic devices **400A** and/or **400B** are to be fabricated, then subsequent SO active layers **130** and magnetic junctions **110** may be formed.

Using the method **500**, the magnetic devices **100**, **100A**, **100B**, **100C**, **100D**, **100E**, **100F**, **100G**, and/or analogous magnetic devices may be fabricated. As a result, the benefits of the magnetic devices **100**, **100A**, **100B**, **100C**, **100D**, **100E**, **100F** and/or **100G** may be achieved.

FIG. **18** depicts an exemplary embodiment of a method **510** for programming a magnetic junction using SO torque. For simplicity, some steps may be omitted, performed in another order, include substeps and/or combined. Further, the method **510** may start after other steps have been

performed. For simplicity, the method **510** is described in the context of the magnetic junction **110**. However, other magnetic junctions, including but not limited to the magnetic junctions **110A**, **1106**, **110C**, **110D**, **110E**, **110F**, **110G**, **110H** and/or an analogous magnetic junction may be programmed.

The desired current is driven through the SO active layer **130**/line **131**, via step **512**. Thus, the current is driven along the axis of the SO active layer **130**/line **131** and substantially [perpendicular] parallel to the sides. In embodiments, in which the current through the SO torque is sufficient to program the device as desired, then the method **510** terminates.

However, in some embodiments, multiple currents are used to program a magnetic junction. Thus, an additional STT current may be driven, via step **512**. In some embodiments, the STT current is driven through the magnetic junctions to be programmed. In such embodiments, the STT current is desired to assist in programming and/or select the final state of the free layer **112**. In other embodiments, the STT current may be driven through magnetic junctions whether or not they are to be programmed. In such embodiments, the direction of the STT current provided in step **514** depends upon whether the magnetic junction **110** is to be programmed. If so, the STT current is driven in a direction that adds to the SO torque. If not, the STT current is driven in a direction such that the STT torque opposes the SO torque. In some embodiments, the current through the SO active layer **130** commence at substantially the same time as the STT current. In other embodiments, the current through the SO active layer is started first, and the STT current commences later. Similarly, in some embodiments, the current through the SO active layer **130** may be terminated before the STT current goes to zero. In other embodiments, the STT current may be terminated before the current through the SO active layer **130**. In still other embodiments, the current through the SO active layer **130** and the STT current through the magnetic junction may be terminated at substantially the same time. However, in most embodiments, the current through the SO active layer **130** and the STT current overlap in time.

Thus, the magnetic junctions **110**, **110A**, **110B**, **110C**, **110D**, **110E**, **110F**, **110G**, **110H**, **212**, **312** and/or **412** may be programmed. As a result, the benefits of the magnetic device(s) **100**, **100A**, **100B**, **100C**, **100D**, **100E**, **100F**, **100G**, **100H**, **200**, **200B**, **200C**, **300A**, **300B**, **400A** and/or **400B** may be achieved.

A method and system for providing and using a magnetic junction and a memory fabricated using the magnetic junction has been described. The method and system have been described in accordance with the exemplary embodiments shown, and one of ordinary skill in the art will readily recognize that there could be variations to the embodiments, and any variations would be within the spirit and scope of the method and system. Accordingly, many modifications may be made by one of ordinary skill in the art without departing from the spirit and scope of the appended claims.

We claim:

1. A magnetic device comprising:

at least one spin-orbit interaction (SO) active layer having a plurality of sides and an axis, the at least one SO active layer carrying a current in at least one direction substantially [perpendicular to the plurality of sides] along the axis; [and]

at least one magnetic junction, each of the at least one magnetic junction being adjacent to the plurality of sides, extending around the axis, and substantially surrounding a portion of the SO active layer, each of the

at least one magnetic junction including a free layer, a reference layer and a nonmagnetic spacer layer, the nonmagnetic spacer layer being between the reference layer and the free layer;

a first line configured to drive a current through the SO active layer along the axis, the at least one SO active layer exerting a SO torque around the axis on the free layer due to the current passing through the at least one SO active layer along the axis, the free layer being switchable between a plurality of stable magnetic states; and

a second line configured to drive current through the at least one magnetic junction.

[2. The magnetic device of claim **1** wherein each of the at least one magnetic junction further includes:

a reference layer; and

a nonmagnetic spacer layer, the nonmagnetic spacer layer being between the reference layer and the free layer.]

3. The magnetic device of claim **1** further comprising:

a substrate, each of the at least one magnetic junction forming a nonzero angle with the substrate.

4. The magnetic device of claim **3** wherein the nonzero angle is substantially ninety degrees.

5. The magnetic device of claim **1** wherein each of the at least one magnetic junction has a substantially circular cross-section.

6. The magnetic device of claim **1** wherein the plurality of stable magnetic states of the free layer are selected from a first stable axis along the at least one direction; a second stable state parallel to the plurality of sides and a radial direction substantially perpendicular to the plurality of sides.

7. The magnetic device of claim **1** wherein the SO active layer has a first resistivity and is part of a line including a core having a second resistivity, the SO active layer substantially surrounding the core, the first resistivity being less than the second resistivity.

8. The magnetic device of claim **1** wherein the at least one magnetic junction is a single magnetic junction and wherein the magnetic device further includes:

a selection device coupled with the at least one SO active layer.

9. The magnetic device of claim **8** wherein the selection device is selected from a planar transistor and a three-dimensional transistor.

10. The magnetic device of claim **7** further comprising: a diode coupled with the reference layer.

11. The magnetic device of claim **1** wherein the at least one magnetic junction is a plurality of magnetic junctions.

12. The magnetic device of claim **11** further comprising: at least one isolation device interleaved with the plurality of magnetic junctions.

13. A magnetic device comprising:

a plurality of spin-orbit interaction (SO) active layers, each of the plurality of SO active layers having a plurality of sides and an axis, each of the plurality of SO active layers carrying a current in at least one direction substantially [perpendicular to the plurality of sides] along the axis;

at least one magnetic junction coupled with each of the plurality of SO active layers, each of the at least one magnetic junction being adjacent to the plurality of sides extending around the axis, and substantially surrounding a portion each of the plurality of SO active layers, each of the at least one magnetic junction including a free layer, a reference layer and a barrier layer, the barrier layer being between the reference layer and the free layer;

19

a first line configured to drive a current through each of the plurality of SO active layers, each of the plurality of SO active layers exerting a SO torque along the axis on the free layer due to the current passing through each of the plurality of SO active layers along the axis, the free layer being switchable between a plurality of stable magnetic states, the plurality of stable magnetic states of the free layer being selected from a first stable axis along the at least one direction; a second stable state parallel to the plurality of sides and a radial direction substantially perpendicular to the plurality of sides; and a plurality of lines coupled with the reference layer of the at least one magnetic junction, the plurality of lines being configured to drive current through the at least one magnetic junction.

14. A method for writing to at least one magnetic junction of a magnetic device comprising:

driving, *with a first line*, a spin-orbit interaction (SO) write current through at least one SO active layer having a plurality of sides *and an axis*, the at least one SO active layer carrying the SO write current in at least one direction substantially [perpendicular to the plurality of sides] *along the axis*, the at least one magnetic junction, each of the at least one magnetic junction being adjacent to the plurality of sides, *extending around the axis*, and substantially surrounding a portion of the SO active layer, each of the at least one magnetic junction including at least a free layer, a reference layer and a nonmagnetic spacer layer, the nonmagnetic

20

spacer layer being between the reference layer and the free layer, the at least one SO active layer exerting a SO torque *along the axis* on the free layer due to the SO write current passing through the at least one SO active layer *along the axis*; and driving, *with a second line*, a spin transfer torque (STT) write current through the at least one magnetic junction.

[15. The method of claim **14** wherein each of the at least one magnetic junction further includes a reference layer and a nonmagnetic spacer layer, the nonmagnetic spacer layer being between the reference layer and the free layer.]

16. The method of claim **[15]** *14* further comprising: driving **[a]** *the* spin transfer torque (STT) write current through the at least one magnetic junction while the SO write current is driven through the SO active layer, a final magnetic state of the free layer being set by the STT write current.

17. The method of claim **[15]** *14* further comprising: driving **[a]** *the* spin transfer torque (STT) write current through the at least one magnetic junction after the SO write current starts to be driven through the SO active layer.

18. The method of claim **[15]** *14* further comprising: driving **[a]** *the* spin transfer torque (STT) write current through the at least one magnetic junction after the SO write current terminates.

* * * * *