



US00RE49763E

(19) **United States**  
(12) **Reissued Patent**  
Le et al.

(10) **Patent Number:** **US RE49,763 E**  
(45) **Date of Reissued Patent:** **\*Dec. 19, 2023**

(54) **FEEDBACK CONTROL FOR HYBRID REGULATOR INCLUDING A BUCK CONVERTER AND A SWITCHED CAPACITOR CONVERTER**

(52) **U.S. Cl.**  
CPC ..... *H02M 3/158* (2013.01); *H02M 3/07* (2013.01); *H02M 3/1584* (2013.01); *H02M 1/007* (2021.05); *H02M 3/155* (2013.01)

(71) Applicant: **Lion Semiconductor Inc.**, Austin, TX (US)

(58) **Field of Classification Search**  
CPC ..... *H02M 3/158*; *H02M 3/07*; *H02M 3/1584*; *H02M 1/007*; *H02M 3/155*; *H02M 3/077*  
See application file for complete search history.

(72) Inventors: **Hanh-Phuc Le**, San Diego, CA (US); **John Crossley**, Oakland, CA (US); **Alberto Alessandro Angelo Puggelli**, Cupertino, CA (US); **Wonyoung Kim**, Los Altos, CA (US)

(56) **References Cited**

U.S. PATENT DOCUMENTS

5,552,694 A 9/1996 Appeltans  
5,999,040 A \* 12/1999 Do ..... *H02M 3/073*  
327/590

(Continued)

FOREIGN PATENT DOCUMENTS

CN 101286698 10/2008  
CN 101647181 2/2010

(Continued)

(\* ) Notice: This patent is subject to a terminal disclaimer.

(21) Appl. No.: **17/407,103**

OTHER PUBLICATIONS

(22) Filed: **Aug. 19, 2021**

European Search Report dated May 31, 2017 in European Patent Application No. 14852747.6.

(Continued)

**Related U.S. Patent Documents**

Reissue of:

(64) Patent No.: **10,389,244**  
Issued: **Aug. 20, 2019**  
Appl. No.: **15/463,613**  
Filed: **Mar. 20, 2017**

*Primary Examiner* — Kenneth Whittington  
(74) *Attorney, Agent, or Firm* — Byrne Poh LLP

U.S. Applications:

(63) Continuation of application No. 14/508,229, filed on Oct. 7, 2014, now Pat. No. 9,601,998.

(Continued)

(57) **ABSTRACT**

A feedback system that can control hybrid regulator topologies that have multiple converters or regulators connected in series is described. The hybrid regulator can include at least two regulators: a switched inductor regulator and a switched-capacitor regulator. The feedback system can simplify feedback design for the hybrid regulator that can include multiple converter stages and can control the feedback to improve the efficiency of a hybrid regulator.

(51) **Int. Cl.**  
*H02M 3/158* (2006.01)  
*H02M 3/07* (2006.01)

(Continued)

**41 Claims, 14 Drawing Sheets**

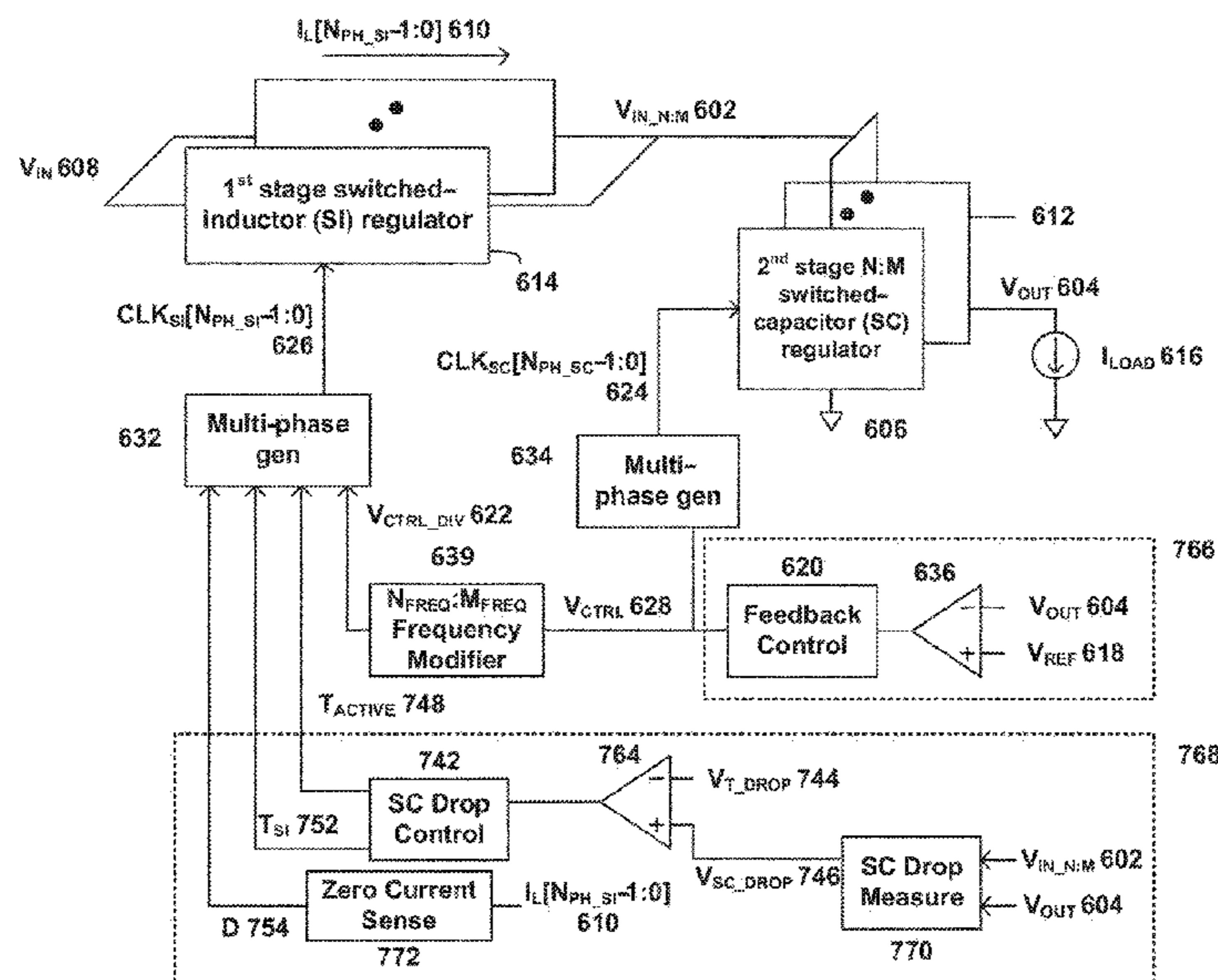

**Related U.S. Application Data**

(60) Provisional application No. 61/887,581, filed on Oct. 7, 2013.

(51) **Int. Cl.**

*H02M 1/00* (2006.01)  
*H02M 3/155* (2006.01)

(56) **References Cited**

U.S. PATENT DOCUMENTS

8,212,539 B2 \* 7/2012 Osaka ..... H02M 3/1584  
323/283  
8,212,541 B2 \* 7/2012 Perreault ..... H02M 3/07  
323/271  
8,305,070 B2 \* 11/2012 Vulih ..... H02M 3/1584  
323/283  
8,564,260 B2 \* 10/2013 Carobolante ..... H02M 3/1588  
323/266  
8,896,367 B1 \* 11/2014 Lin ..... H02M 3/073  
363/60  
2006/0250177 A1 \* 11/2006 Thorp ..... H02M 3/073  
327/536  
2008/0157732 A1 7/2008 Williams  
2008/0158915 A1 \* 7/2008 Williams ..... H02M 3/1588  
363/21.06  
2008/0238390 A1 \* 10/2008 Trivedi ..... H02M 3/1584  
323/283  
2009/0206804 A1 8/2009 Xu et al.  
2009/0278520 A1 11/2009 Perreault et al.  
2010/0066323 A1 \* 3/2010 Moussaoui ..... H02M 3/157  
323/282  
2011/0221482 A1 9/2011 Kim et al.  
2012/0257429 A1 10/2012 Dong et al.  
2013/0093514 A1 \* 4/2013 Xu ..... H02M 3/1582  
330/129  
2013/0154600 A1 6/2013 Giuliano  
2014/0022005 A1 \* 1/2014 Ramanan ..... H02M 3/07  
327/536  
2014/0266132 A1 \* 9/2014 Low ..... H02M 3/073  
323/311  
2015/0028839 A1 \* 1/2015 Petrovic ..... H02M 3/07  
323/311

FOREIGN PATENT DOCUMENTS

CN 103337901 10/2013  
EP 2493060 8/2012  
JP 1977017648 2/1977  
JP 1995087732 3/1995  
JP 2008167506 7/2008  
JP 2009017772 1/2009  
JP 2010515419 5/2010  
JP 2013065939 4/2013  
WO WO2008082578 7/2008  
WO WO2010130588 11/2010  
WO WO2010151466 11/2012

OTHER PUBLICATIONS

International Preliminary Report on Patentability dated Apr. 12, 2018 in International Patent Application No. PCT/US2014/059404.  
International Search Report and Written Opinion Issued by the European Patent Office as International Searching Authority for International Application No. PCT/US2014/033759 dated Feb. 4, 2015, pp. 1-18.  
International Search Report and Written Opinion Issued by the Korean Intellectual Property Office as International Searching Authority for International Patent Application No. PCT/US2014/059404 dated Jan. 27, 2015, pp. 1-18.  
Kim et al., "A Fully-Integrated 3-Level DC-DC Converter for Nanosecond-Scale DVFS", in IEEE Journal of Solid-State Circuits, vol. 47, No. 1, Jan. 2012, pp. 1-14.  
Kim et al., "System Level Analysis of Fast, Per-Core DVFS Using On-Chip Switching Regulators", in IEEE International Symposium of High-Performance Computer Architecture (HPCA), Feb. 2008, pp. 1-12.  
Le et al., "Design Techniques for Fully Integrated Switched-Capacitor DC-DC Converters", in IEEE Journal of Solid-State Circuits, vol. 46, No. 9, Sep. 2011, pp. 2120-2131.  
Notice of Allowance dated Oct. 18, 2016 in U.S. Appl. No. 14/508,229.  
Office Action dated Apr. 4, 2016 in U.S. Appl. No. 14/508,229.  
Office Action dated May 10, 2017 in CN Patent Application No. 2014800550349.  
Office Action dated Jul. 8, 2016 in U.S. Appl. No. 14/508,229.  
Office Action dated Jan. 30, 2018 in CN Patent Application No. 2014800550349.  
Office Action dated Jul. 31, 2018 in JP Patent Application No. 2016-518738.

\* cited by examiner

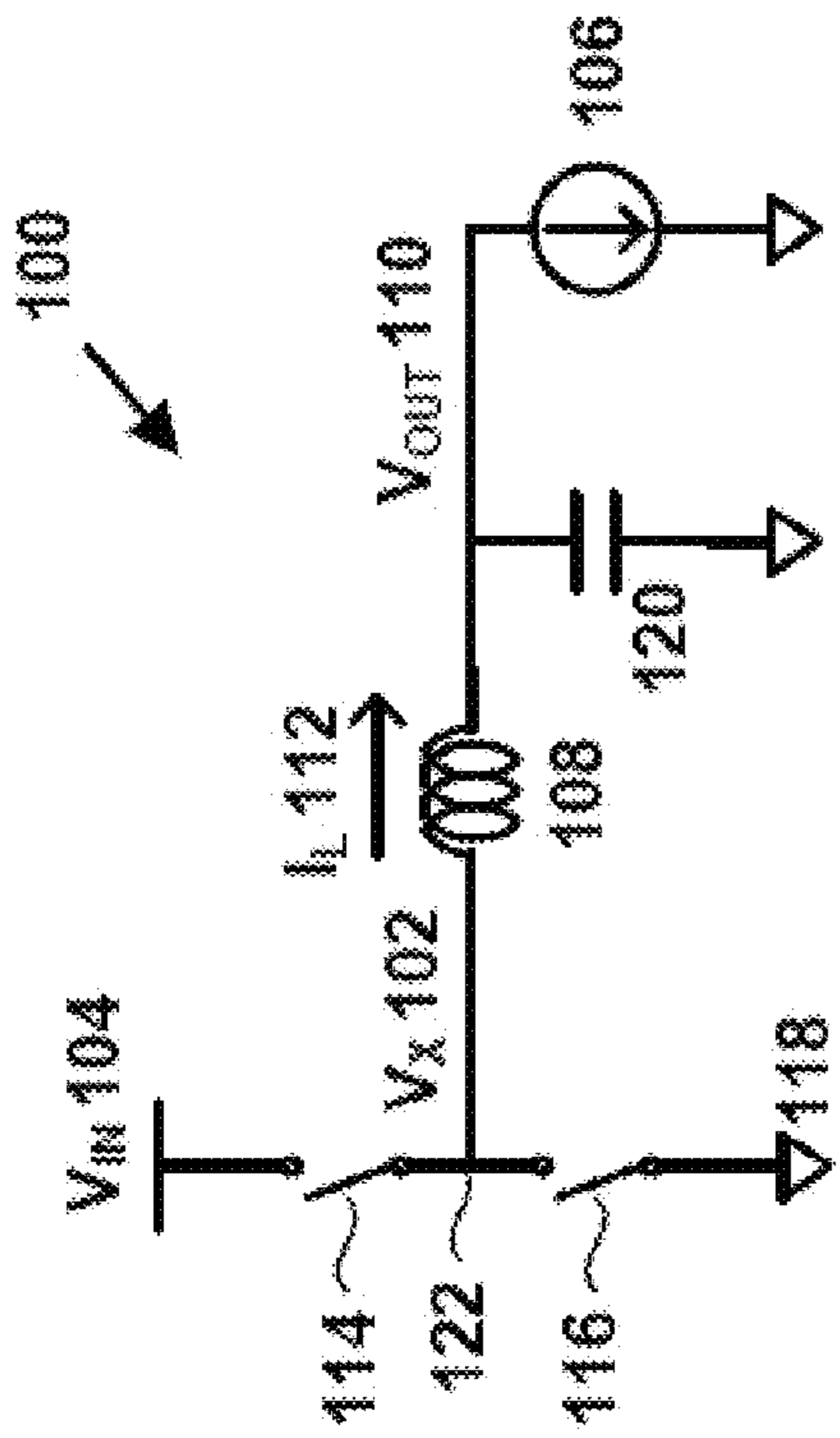

FIG. 1A

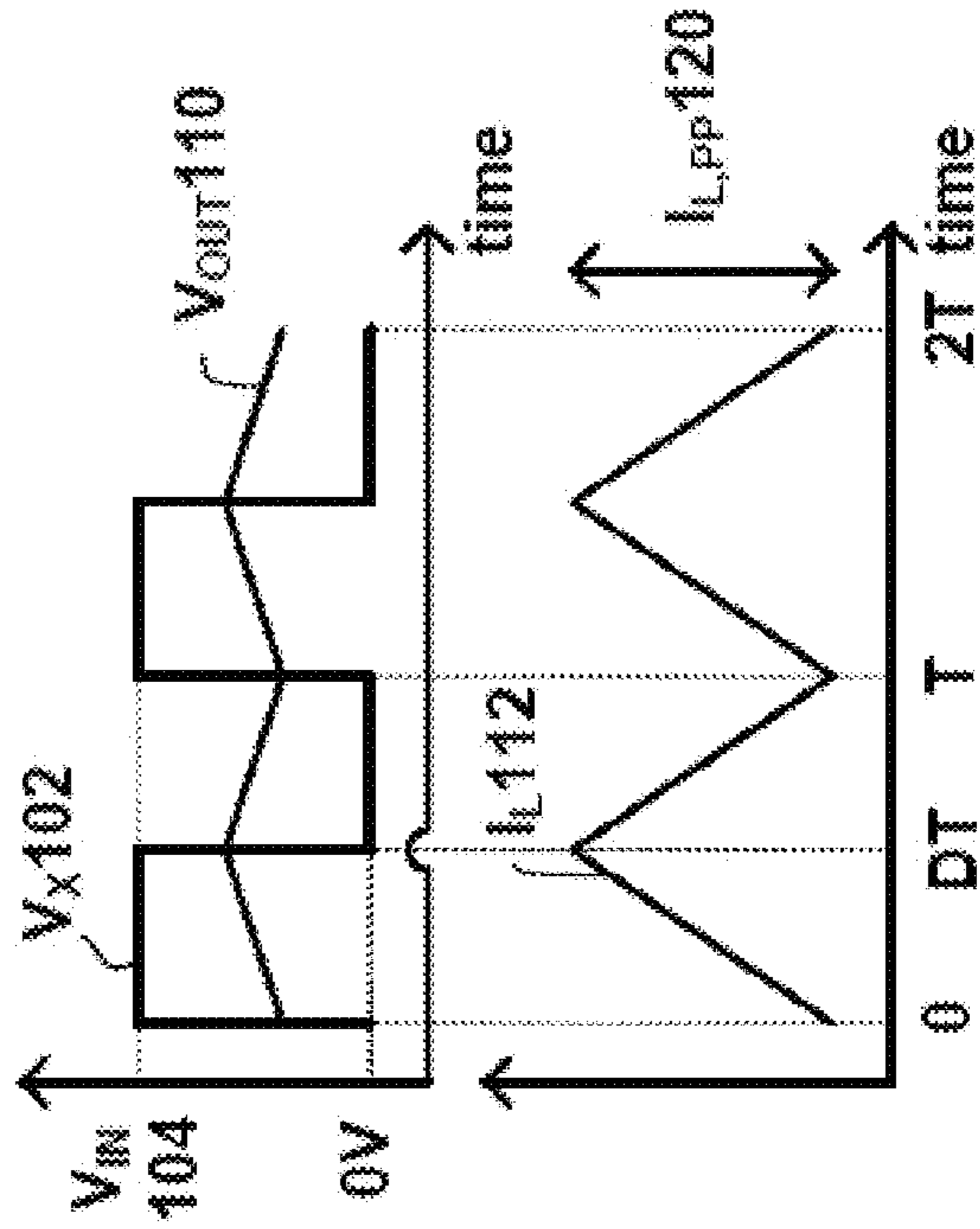

FIG. 1B



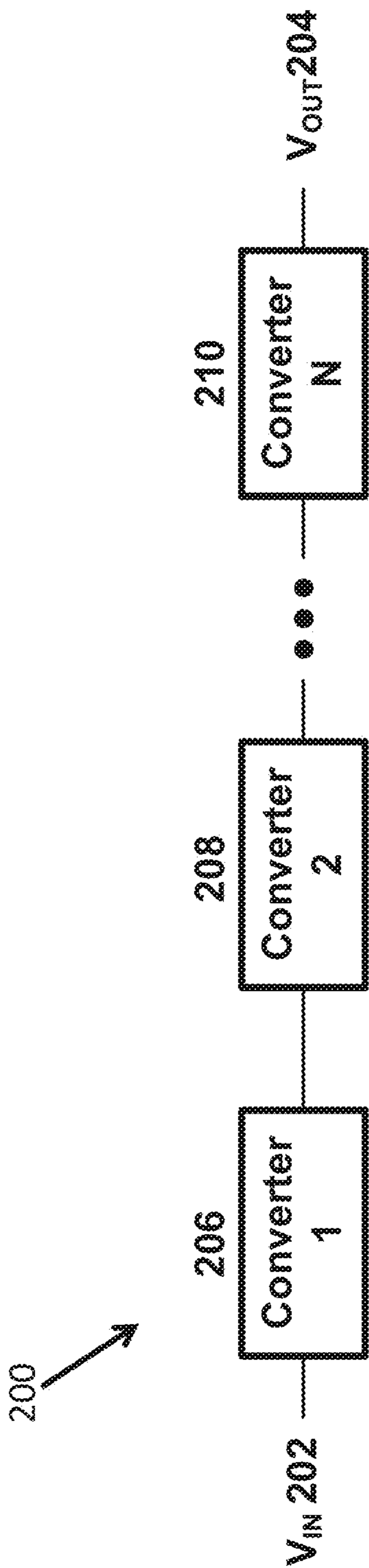

FIG. 2A

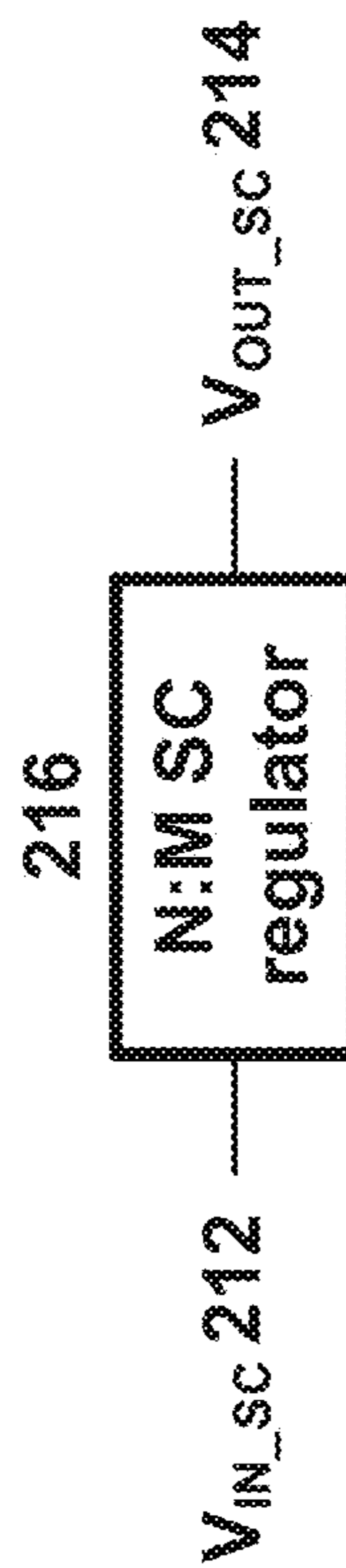

FIG. 2B

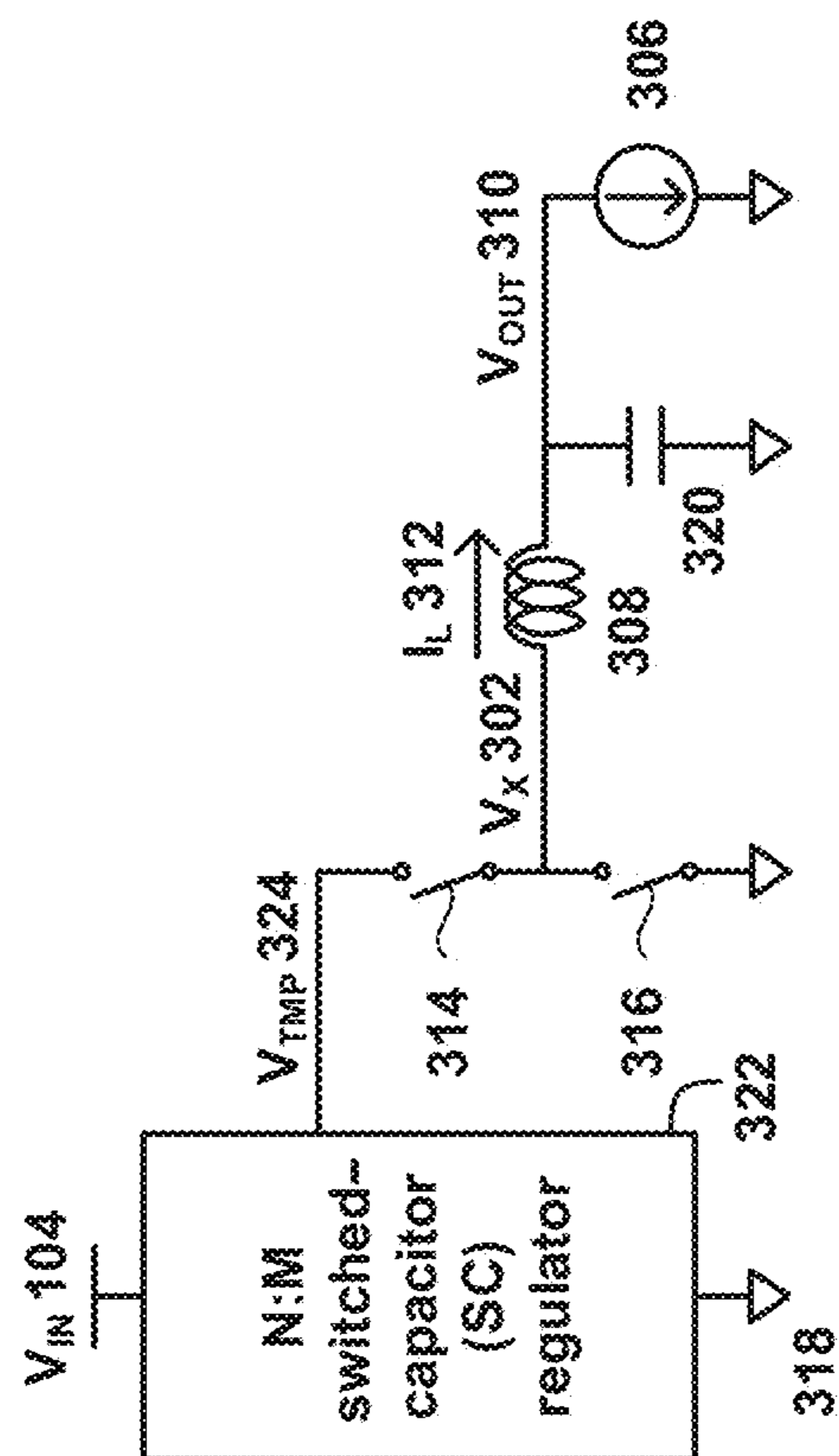

FIG. 3A

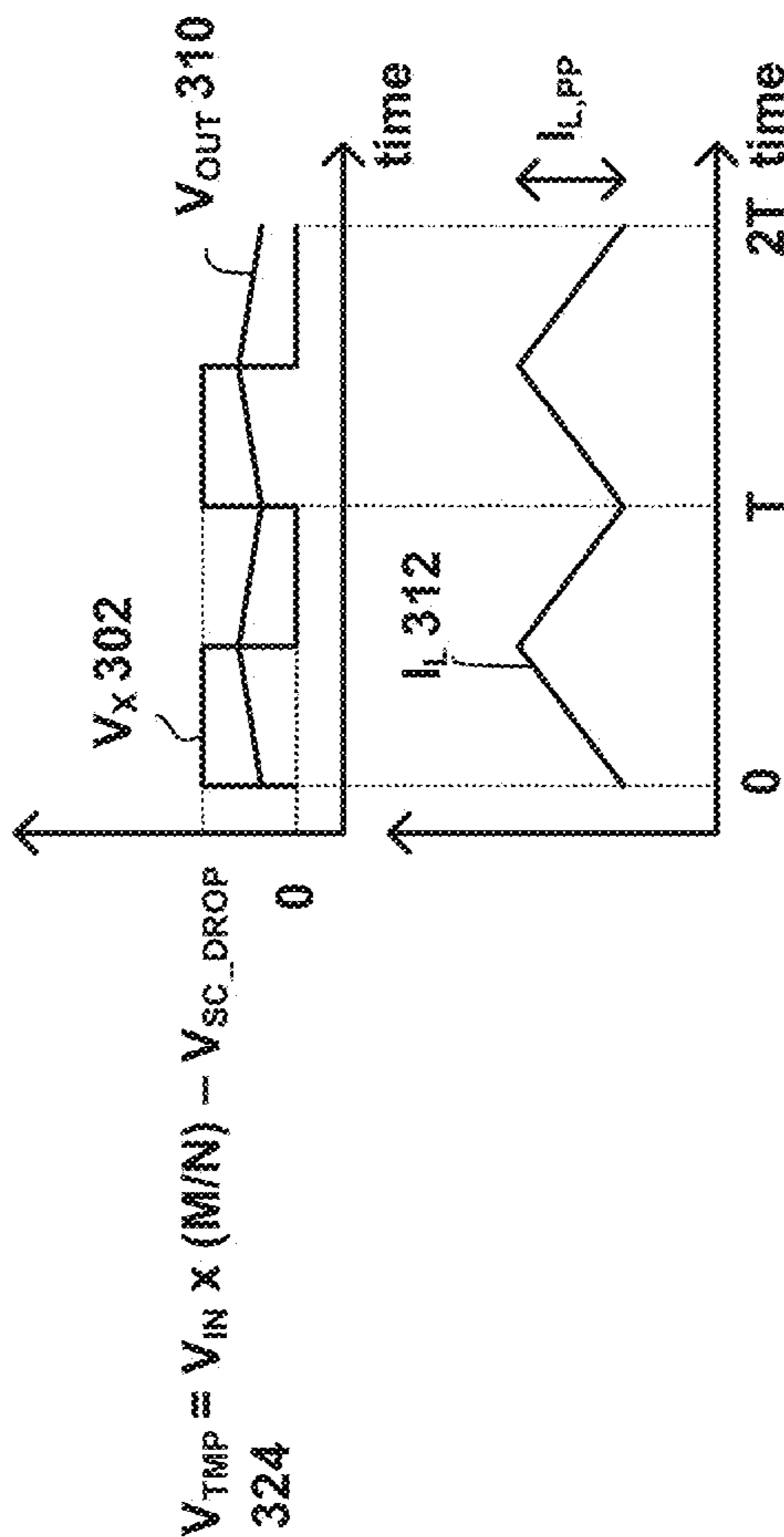

FIG. 3B

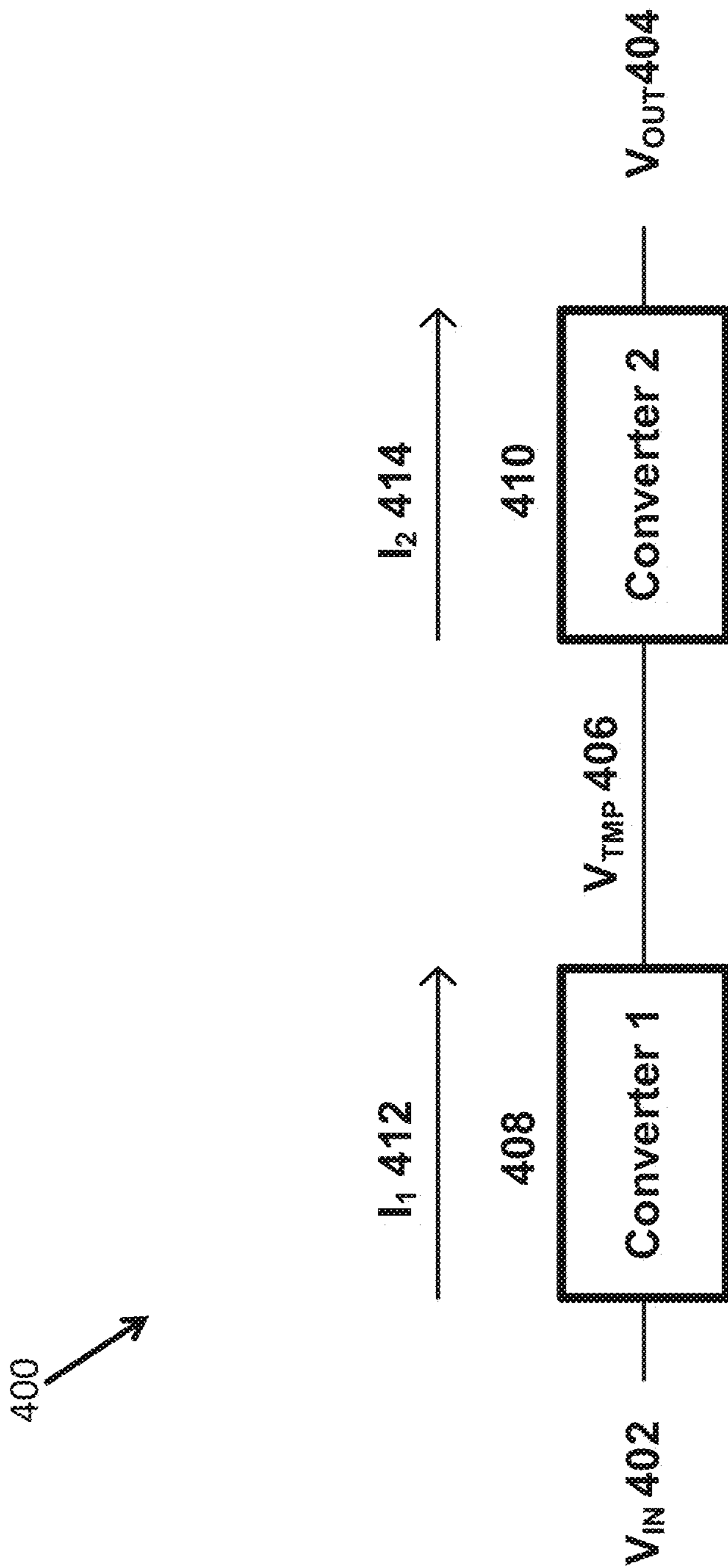
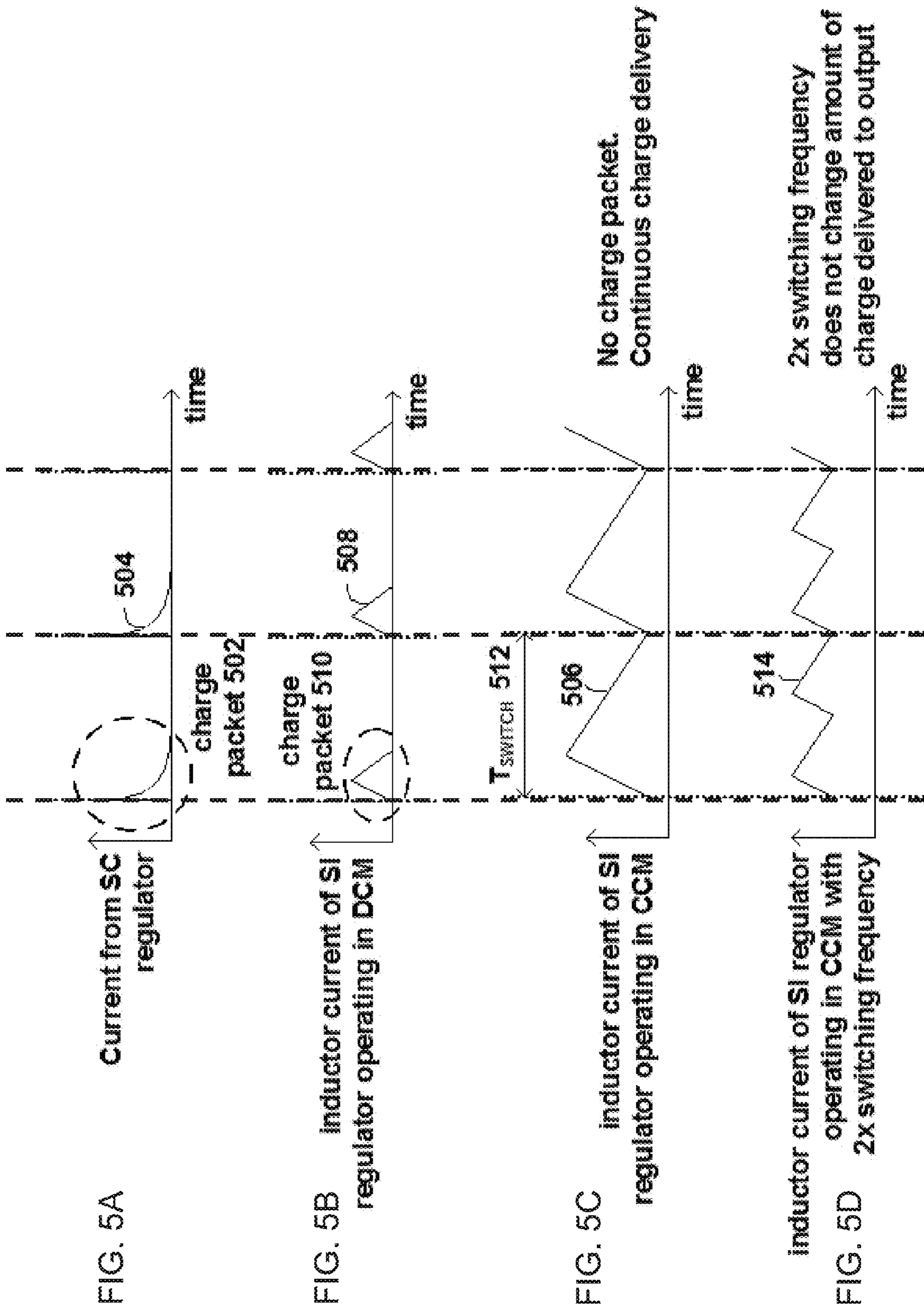

FIG. 4



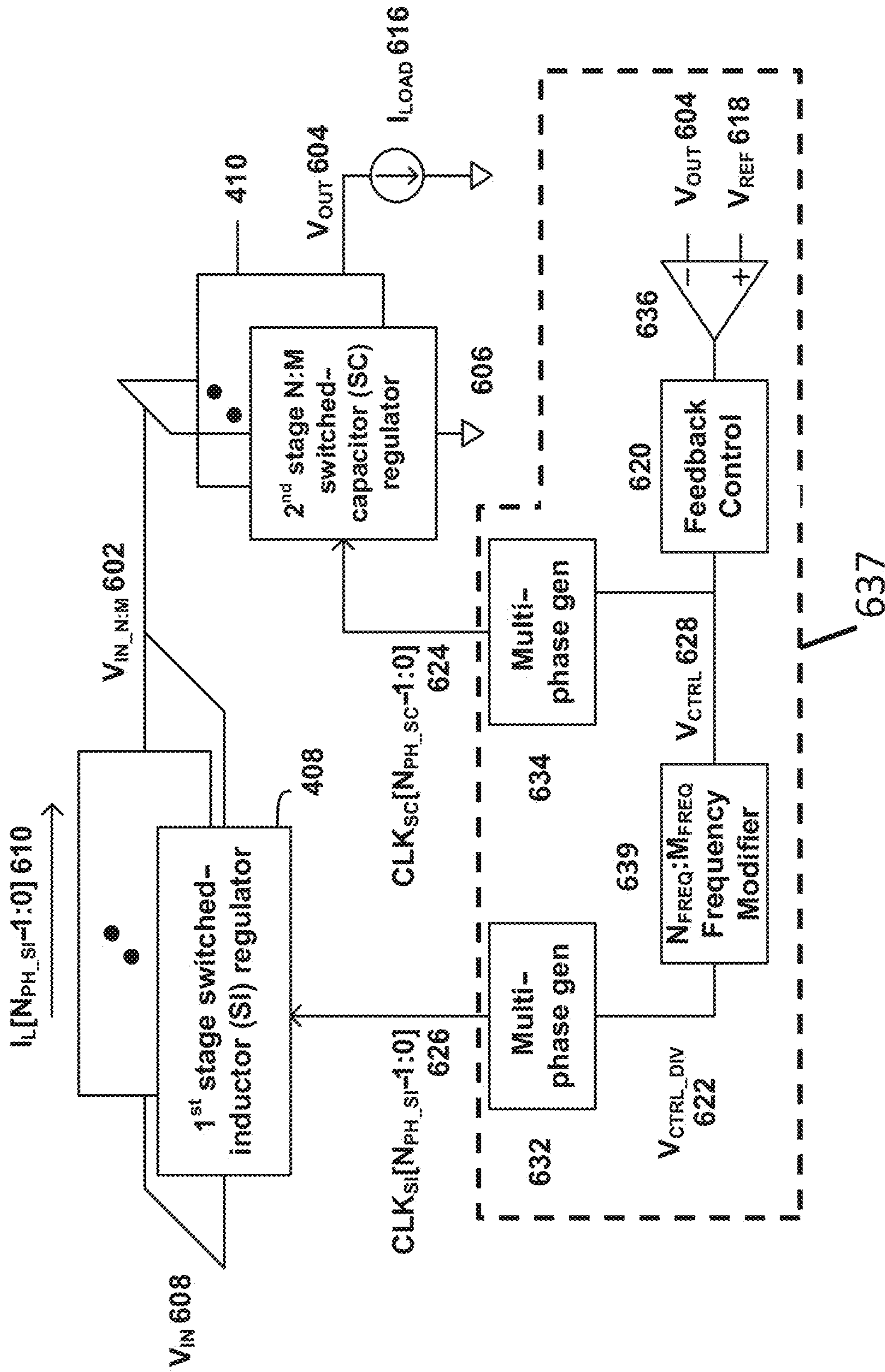

FIG. 6A



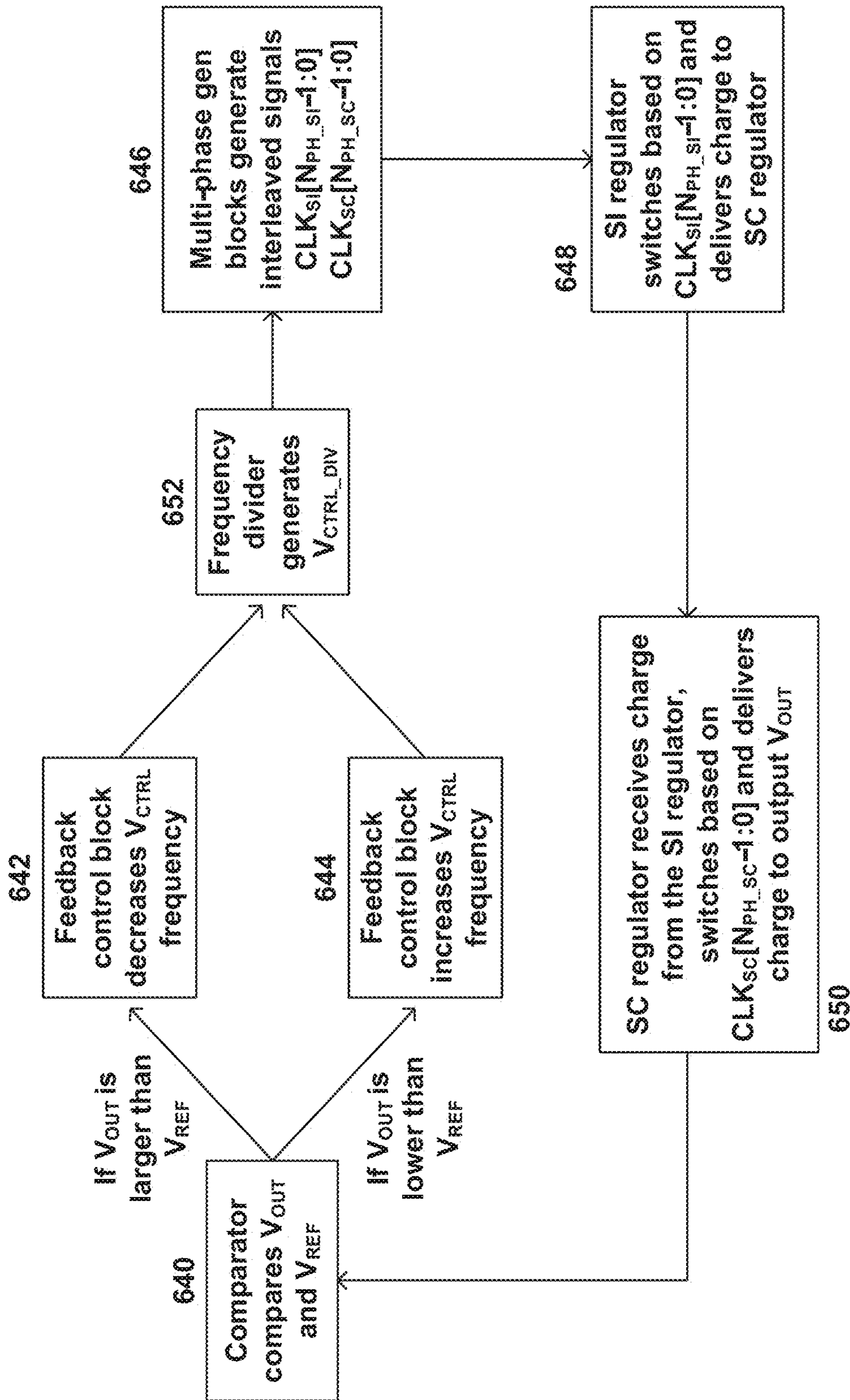

FIG. 6B

Example) If  $N_{PH\_SC} = 4$ ,  $N_{PH\_SI} = 2$ ,  $N_{FREQ} = 1$ ,  $M_{FREQ} = 1$

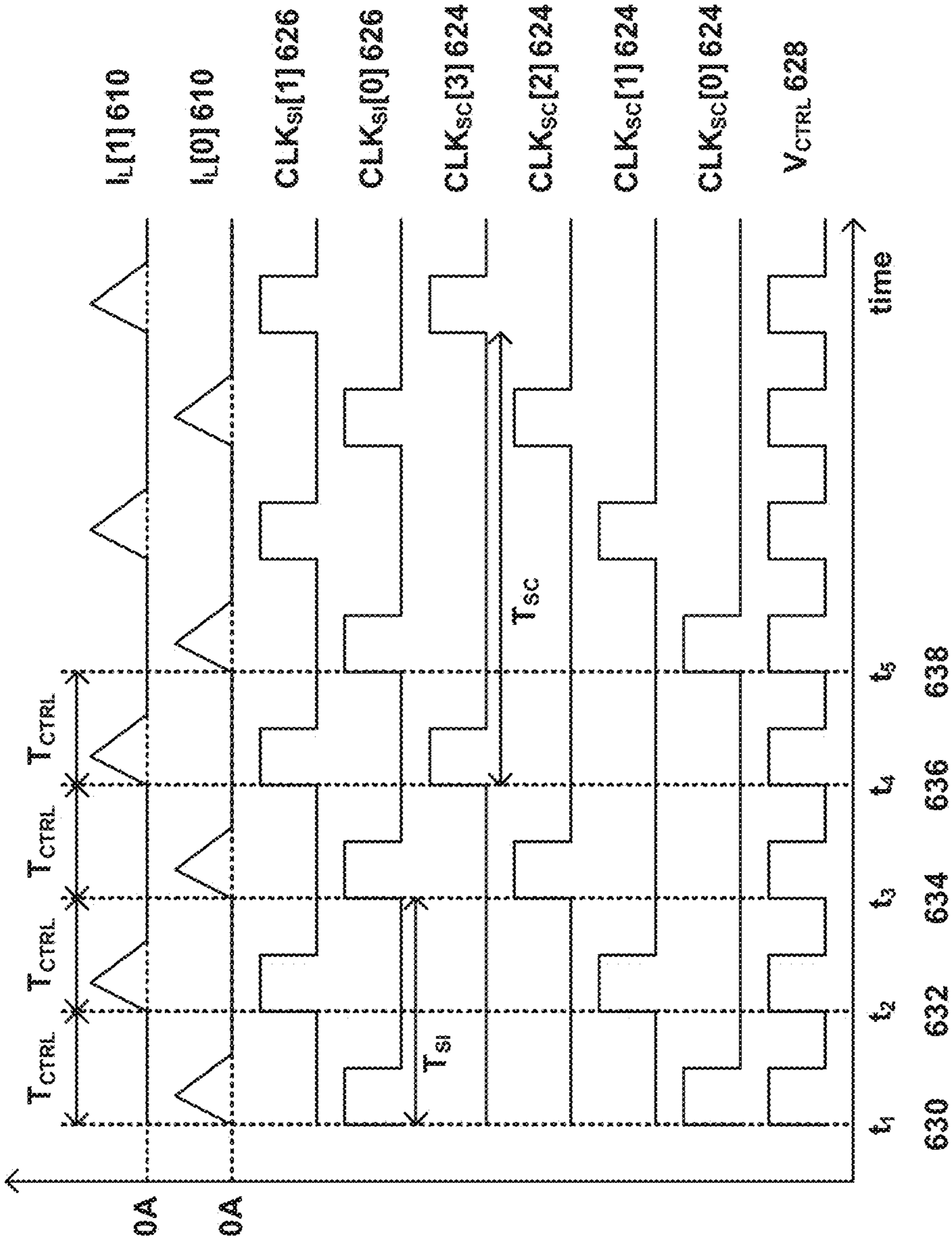

FIG. 6C

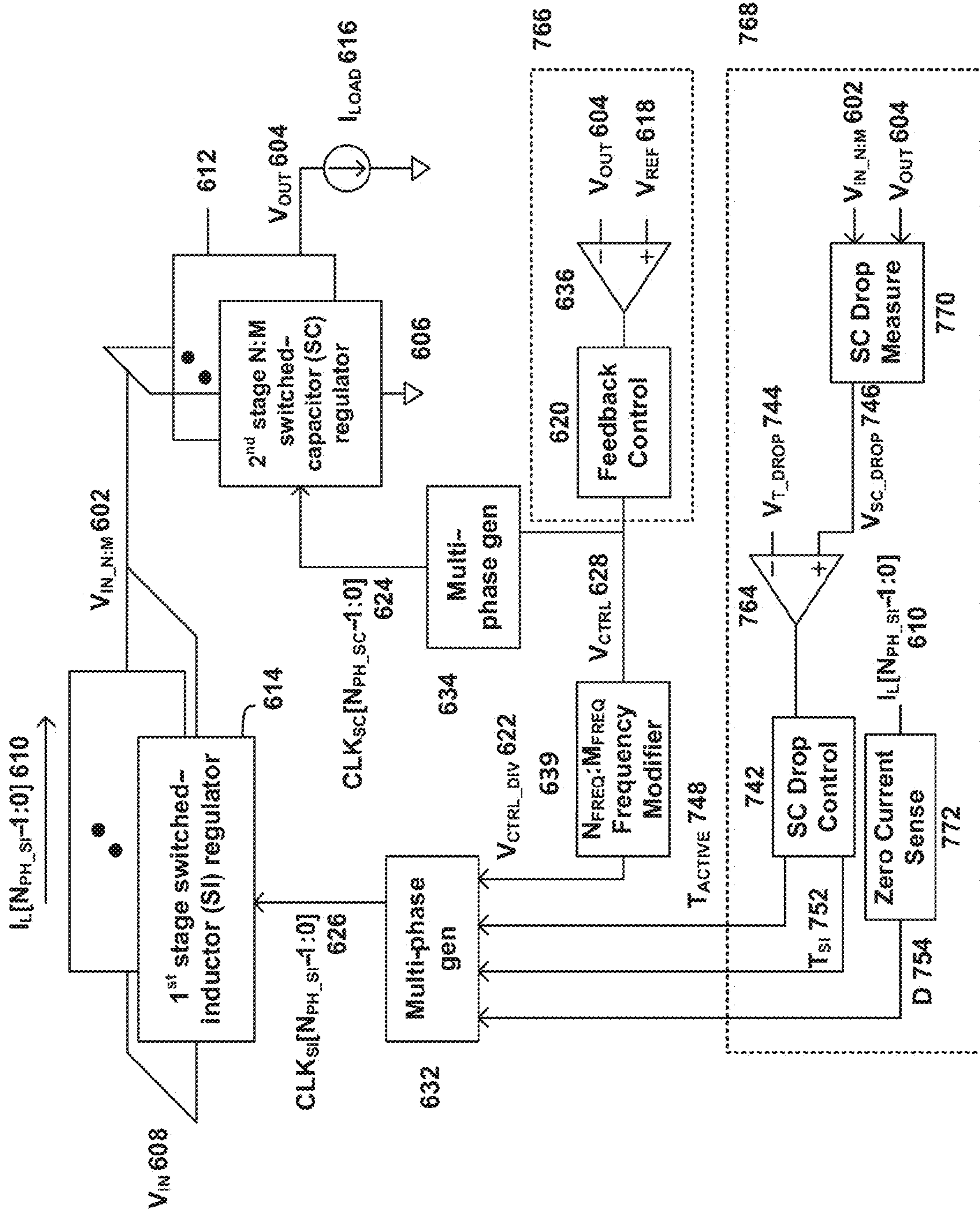

FIG. 7A

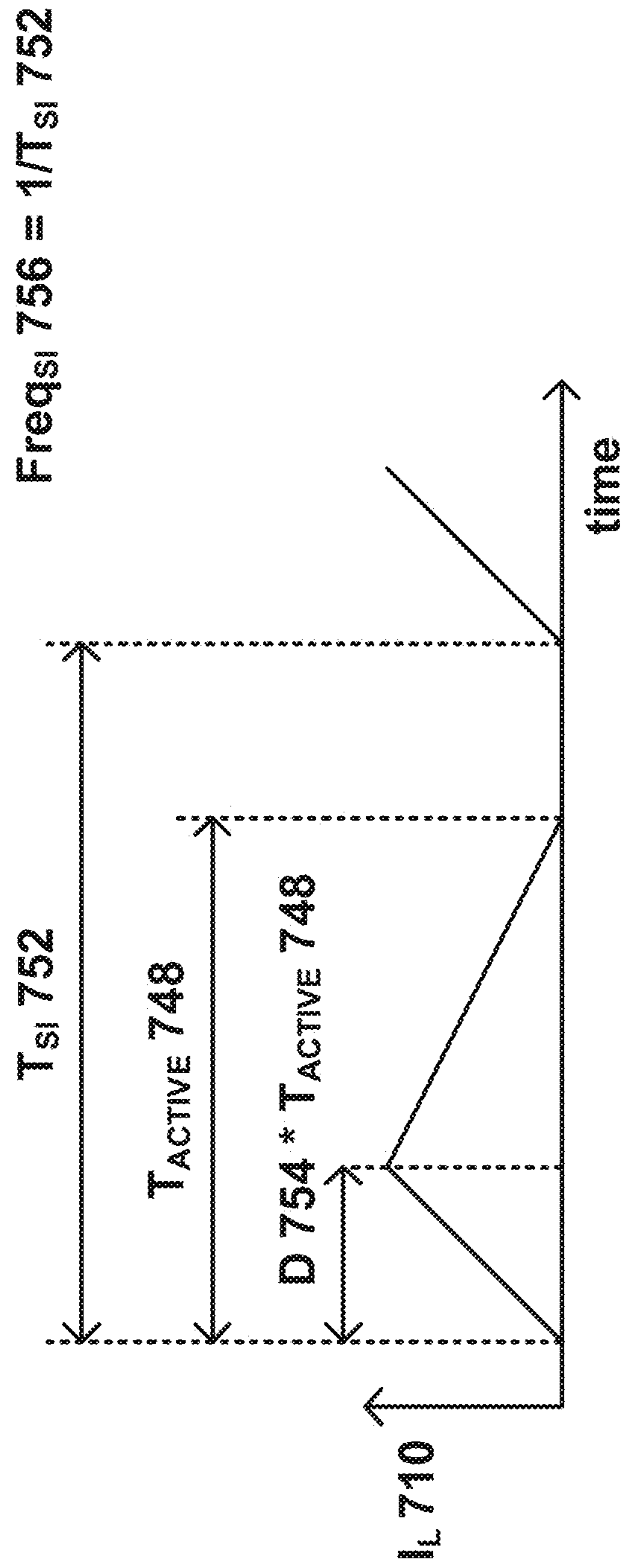

FIG. 7B



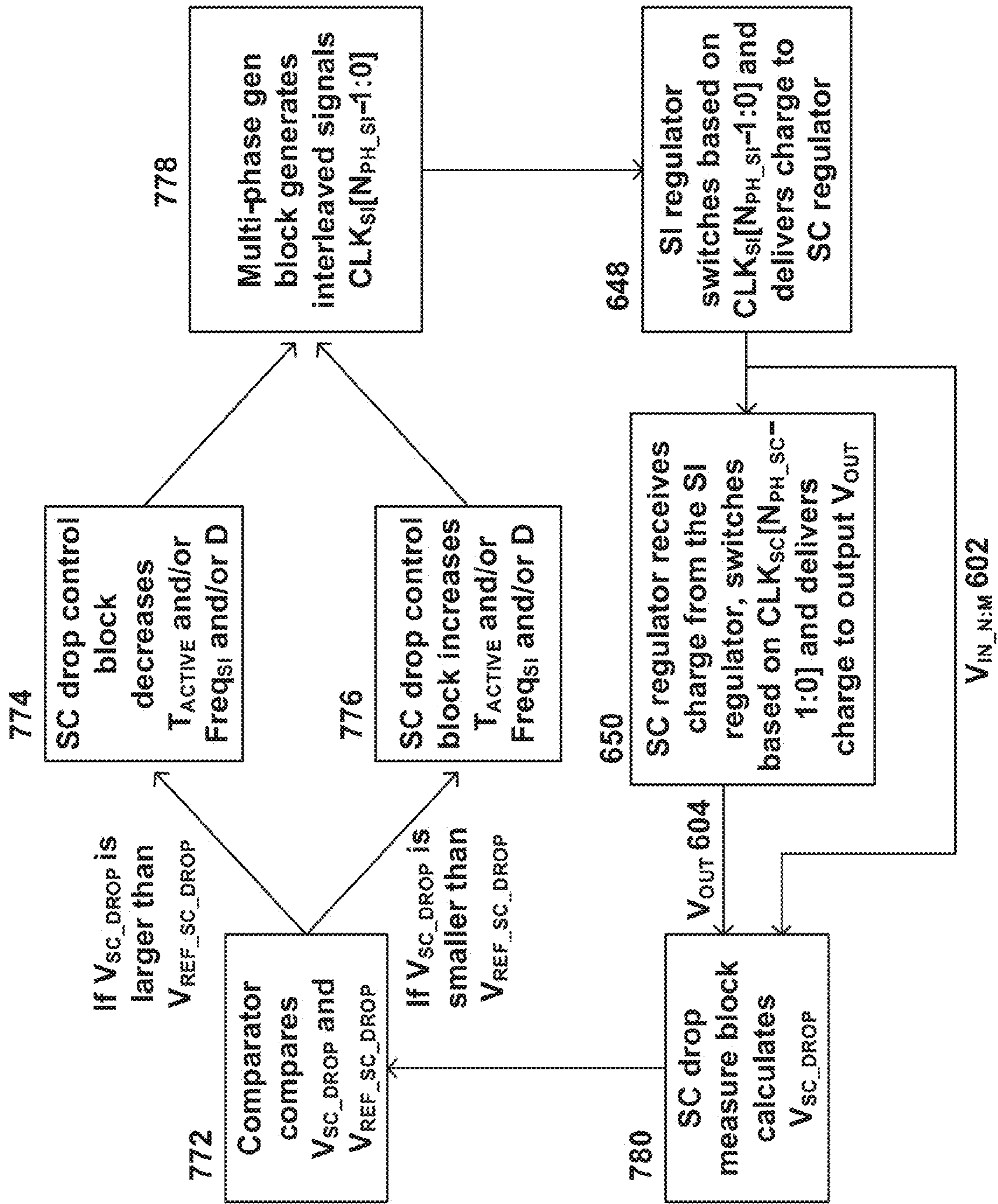

FIG. 7C

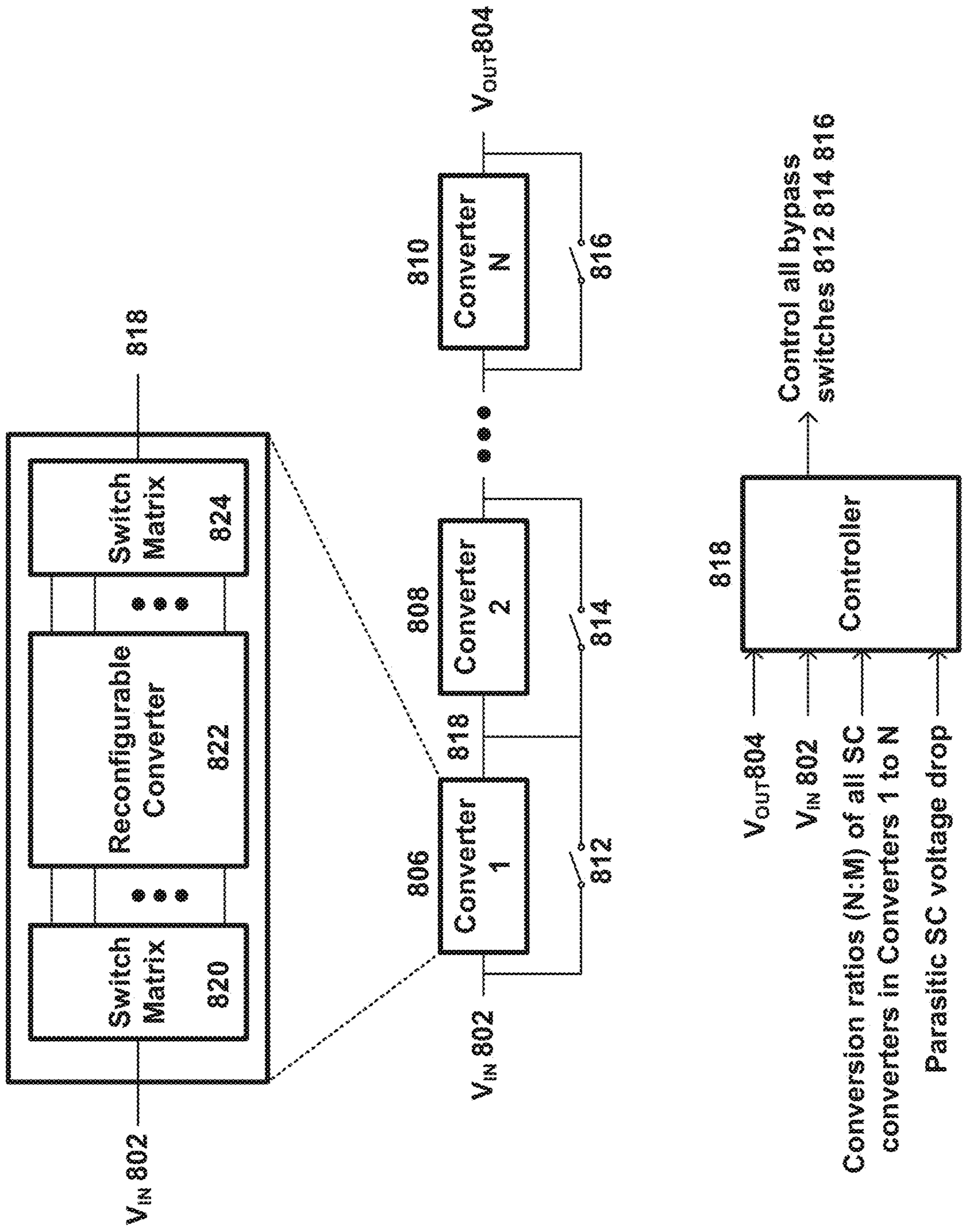

FIG. 8



902

	Switches On	Switches Off	Description
6 <	none	1, 2, 3	Use converters 1,2,3
3 < and 6	1	2, 3	Use converters 2,3
2 < and 3	2	1, 3	Use converters 1,3
2	1, 2	3	Use converter 3

FIG. 9

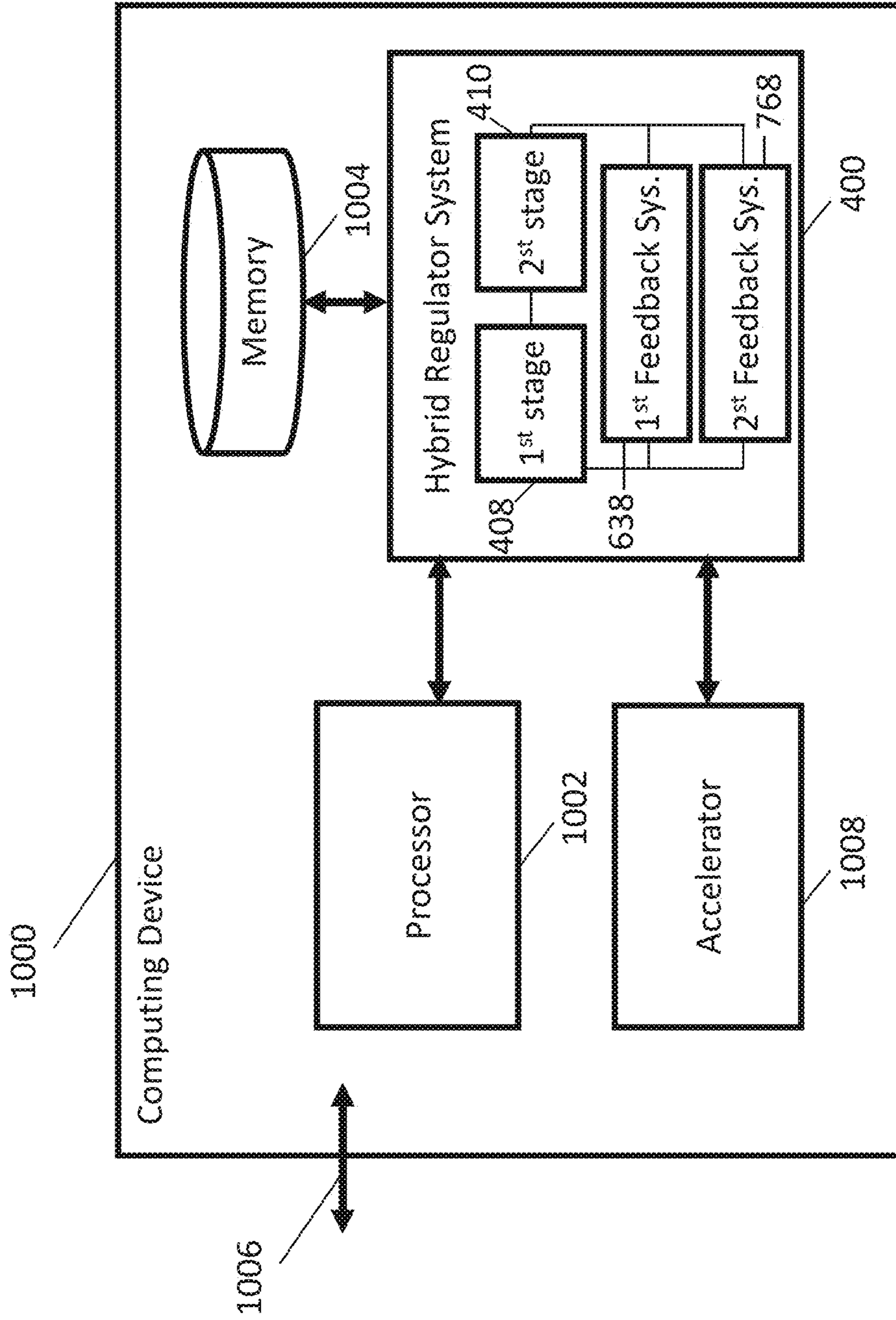

FIG. 10



**FEEDBACK CONTROL FOR HYBRID  
REGULATOR INCLUDING A BUCK  
CONVERTER AND A SWITCHED  
CAPACITOR CONVERTER**

**Matter enclosed in heavy brackets [ ] appears in the original patent but forms no part of this reissue specification; matter printed in italics indicates the additions made by reissue; a claim printed with strikethrough indicates that the claim was canceled, disclaimed, or held invalid by a prior post-patent action or proceeding.**

CROSS-REFERENCE TO RELATED  
APPLICATION

This application is a continuation application of U.S. patent application Ser. No. 14/508,229, titled "A Hybrid Regulator Including a Buck Converter and a Switched Capacitor Converter," filed on Oct. 7, 2014, by Le et al., which claims the benefit of the earlier priority date of U.S. Provisional Patent Application No. 61/887,581, entitled "APPARATUS, SYSTEMS, AND METHODS FOR PROVIDING FEEDBACK CONTROL IN HYBRID VOLTAGE REGULATORS," filed on Oct. 7, 2013, by Le et al., each of which is expressly incorporated herein by reference in its entirety.

STATEMENT REGARDING FEDERALLY  
SPONSORED RESEARCH OR DEVELOPMENT

This invention was made with government support under 1248828 and 1353640 awarded by the National Science Foundation (NSF). The government has certain rights in the invention.

TECHNICAL FIELD

The present disclosure relates to feedback control in hybrid voltage regulators.

BACKGROUND

There is a strong demand to reduce the size of electronic systems. The size reduction is especially desirable in mobile electronic devices in which the space is a premium, but is also desirable in servers that are placed in big data centers since it is important to squeeze in as many servers as possible in a fixed real estate.

One of the largest components in electronic systems is a voltage regulator (also referred to as a power regulator). A voltage regulator can include a semiconductor chip, such as a DC-DC regulator chip, that delivers voltage from a voltage source (e.g., a battery) to an output load. The output load can include a variety of integrated chips (e.g., an application processor, a processor, a memory device, such as a dynamic read access memory (DRAM) and a NAND flash memory, radio-frequency (RF) chips, WiFi combo chips, and power amplifiers) in an electronic device. Unfortunately, a voltage regulator can include many bulky electronic components. Since each integrated chip may need a dedicated voltage regulator, it is desirable to reduce the size of the voltage regulators in electronic systems.

A voltage regulator can include a switched-inductor regulator. A switched-inductor regulator transfers charges from the power source to the output load using an inductor. A switched-inductor regulator can use power switches to con-

nect/disconnect the inductor to one of multiple voltages, and provide an output voltage that is a weighted average of the multiple voltages. A switched-inductor regulator can adjust the output voltage by controlling the amount of time the inductor is coupled to one of the multiple voltages.

Unfortunately, a switched-inductor regulator is often not suitable for highly integrated electronic systems. The conversion efficiency of a switched-inductor regulator depends on the quality and size of the inductor, in particular when the power conversion ratio is high and when the amount of current consumed by the output load is high. Because an inductor can occupy a large area and is bulky to integrate on-die or on-package, existing switched-inductor regulators often use a large number of off-chip inductor components. This strategy often requires a large area on the printed circuit board, which in turn increases the size of the electronic device. The challenge is exacerbated as mobile system-on-chips (SoCs) become more complex and need increasingly larger number of voltage domains to be delivered by the voltage regulator.

SUMMARY

Some embodiments of the disclosed subject matter include a voltage regulator system. The voltage regulator system includes a hybrid regulator configured to convert an input voltage to an output voltage, wherein the hybrid regulator comprises a plurality of voltage regulators including at least a switched-inductor regulator and a switched-capacitor regulator, and wherein the switched-inductor regulator is configured to operate in a discontinuous conduction mode. The voltage regulator system can also include a first feedback system configured to compare the output voltage to a reference voltage to determine a first operating frequency of the switched-inductor regulator and a second operating frequency of the switched-capacitor regulator, cause the switched-inductor regulator to operate at the first operating frequency, and cause the switched-capacitor regulator to operate at the second operating frequency, thereby causing the hybrid regulator to provide the output voltage that is within a tolerance range of the reference voltage.

In any of the disclosed embodiments disclosed herein, the first feedback system can be configured to cause the switched-inductor regulator to operate at the first operating frequency by providing a first periodic signal having the first operating frequency to the switched-inductor regulator.

In any of the disclosed embodiments disclosed herein, the switched-inductor regulator comprises a multi-phase switched-inductor regulator having a plurality of regulator cells, and wherein the first feedback system can be configured to cause the switched-inductor regulator to operate at the first operating frequency by providing a plurality of periodic signals having the first operating frequency to the switched-inductor regulator, wherein the plurality of periodic signals are out-of-phase from one another.

In any of the disclosed embodiments disclosed herein, the feedback system comprises a feedback control that can be configured to generate a first periodic signal, based on the reference voltage and the output voltage, having the second operating frequency.

In any of the disclosed embodiments disclosed herein, the feedback system comprises a frequency divider that can be configured to receive the first periodic signal generated by the feedback control and to generate a second periodic signal having the first operating frequency, and wherein the feedback system can be configured to provide the first periodic



signal to the switched-capacitor regulator and the second periodic signal to the switched-inductor regulator.

In any of the disclosed embodiments disclosed herein, the voltage regulator system can include a second feedback system that can be configured to determine a difference between a parasitic voltage drop and a target voltage drop of the switched-capacitor regulator and cause the switched-inductor regulator to adjust current provided to the switched-capacitor regulator based on the difference.

In any of the disclosed embodiments disclosed herein, the second feedback system can be configured to cause the switched-inductor regulator to adjust the current provided to the switched-capacitor regulator by adjusting one or more of a switching period, an active period, and a duty cycle D of the switched-inductor regulator.

In any of the disclosed embodiments disclosed herein, the first operating frequency can be a fraction of the second operating frequency.

In any of the disclosed embodiments disclosed herein, the voltage regulator system can include a plurality of bypass switches, wherein one of the bypass switches can be configured to couple an input node of a first voltage regulator and an output node of a second voltage regulator in the hybrid regulator.

In any of the disclosed embodiments disclosed herein, the voltage regulator system can include a control block configured to determine a status of the bypass switches based on one or more of: the input voltage of the hybrid regulator, the output voltage of the hybrid regulator, and a conversion ratio of the switched-capacitor regulator in the hybrid regulator.

Some embodiments of the disclosed subject matter include an electronic system. The electronic system can include a load chip comprising a power domain, wherein the power domain comprises a first input voltage terminal and a first ground terminal, and a voltage regulator system in accordance with any of the disclosed embodiments disclosed herein, wherein the voltage regulator system can be configured to provide the output voltage of the voltage regulator system to the first input voltage terminal of the load chip.

Some embodiments of the disclosed subject matter include a method of providing an output voltage based on an input voltage. The method includes providing a hybrid regulator configured to convert the input voltage to the output voltage, wherein the hybrid regulator comprises a plurality of voltage regulators including at least a switched-inductor regulator and a switched-capacitor regulator, and wherein the switched-inductor regulator can be configured to operate in a discontinuous conduction mode, comparing, at a first feedback system, the output voltage to a reference voltage to determine a first operating frequency of the switched-inductor regulator and a second operating frequency of the switched-capacitor regulator, causing, by the first feedback system, the switched-inductor regulator to operate at the first operating frequency, and causing, by the first feedback system, the switched-capacitor regulator to operate at the second operating frequency, thereby causing the hybrid regulator to provide the output voltage that can be within a tolerance range of the reference voltage.

In any of the disclosed embodiments disclosed herein, causing the switched-inductor regulator to operate at the first operating frequency comprises providing a first periodic signal having the first operating frequency to the switched-inductor regulator.

In any of the disclosed embodiments disclosed herein, the switched-inductor regulator comprises a multi-phase switched-inductor regulator having a plurality of regulator cells, and wherein causing the switched-inductor regulator

to operate at the first operating frequency comprises providing a plurality of periodic signals having the first operating frequency to the switched-inductor regulator, wherein the plurality of periodic signals are out-of-phase from one another.

In any of the disclosed embodiments disclosed herein, the method further includes generating, at a feedback control in the feedback system, a first periodic signal having the second operating frequency based on the reference voltage and the output voltage.

In any of the disclosed embodiments disclosed herein, the method further includes receiving, at a frequency divider in the feedback system, the first periodic signal generated by the feedback control, generating, by the frequency divider, a second periodic signal having the first operating frequency, and providing the first periodic signal to the switched-capacitor regulator and the second periodic signal to the switched-inductor regulator.

In any of the disclosed embodiments disclosed herein, the method further includes determining a difference between a parasitic voltage drop and a target voltage drop of the switched-capacitor regulator, and causing the switched-inductor regulator to adjust current provided to the switched-capacitor regulator based on the difference.

In any of the disclosed embodiments disclosed herein, causing the switched-inductor regulator to adjust the current provided to the switched-capacitor regulator by adjusting one or more of: a switching period, an active period, and a duty cycle D of the switched-inductor regulator.

In any of the disclosed embodiments disclosed herein, the hybrid regulator system comprises a plurality of bypass switches, wherein one of the bypass switches can be configured to couple an input node and an output node of the one of the voltage regulators in the hybrid regulator.

In any of the disclosed embodiments disclosed herein, the method further includes determining a status of the bypass switches based on one or more of: the input voltage of the hybrid regulator, the output voltage of the hybrid regulator, and a conversion ratio of the switched-capacitor regulator in the hybrid regulator.

#### BRIEF DESCRIPTION OF THE DRAWINGS

Various objects, features, and advantages of the disclosed subject matter can be more fully appreciated with reference to the following detailed description of the disclosed subject matter when considered in connection with the following drawings, in which like reference numerals identify like elements.

FIGS. 1A-1B illustrate a step-down switched-inductor regulator and its operation.

FIGS. 2A-2B illustrate a high-level diagram of a hybrid voltage regulator that has multiple converters connected in series, which can be either switched-inductor regulators or switched-capacitor regulators.

FIGS. 3A-3B illustrate a hybrid voltage regulator that includes a step-down switched-capacitor regulator at the first-stage and a switched-inductor regulator at the second stage.

FIG. 4 illustrates a high-level diagram of a hybrid voltage regulator with two converter stages in accordance with some embodiments.

FIGS. 5A-5D illustrate current waveforms of switched-inductor and switched-capacitor regulators in accordance with some embodiments.

FIGS. 6A-6C illustrate a multi-phase hybrid voltage regulator system and its operation, where the hybrid voltage



5

regulator system includes a first feedback system configured to control the first stage switched-inductor regulator and second stage switched-capacitor regulator in accordance with some embodiments.

FIGS. 7A-7C illustrate a multi-phase hybrid voltage regulator system and its operation, where the hybrid voltage regulator system includes the first feedback system and the second feedback system configured to improve the efficiency of the second-stage switched-capacitor regulator in accordance with some embodiments.

FIG. 8 illustrates a hybrid regulator system in which bypass switches can turn on to bypass certain converter stages in accordance with some embodiments.

FIG. 9 illustrates a lookup table for controlling bypass switches in accordance with some embodiments.

FIG. 10 shows a block diagram of a computing device in accordance with some embodiments.

#### DETAILED DESCRIPTION

In the following description, numerous specific details are set forth regarding the apparatus, systems, and methods of the disclosed subject matter and the environment in which such apparatus, systems, and methods may operate, etc., in order to provide a thorough understanding of the disclosed subject matter. It will be apparent to one skilled in the art, however, that the disclosed subject matter may be practiced without such specific details, and that certain features, which are well known in the art, are not described in detail in order to avoid complication of the disclosed subject matter. In addition, it will be understood that the examples provided below are exemplary, and that it is contemplated that there are other apparatus, systems, and methods that are within the scope of the disclosed subject matter.

Modern electronic systems have been tightly integrated as a system-on-chip (SoC) that includes multiple processing cores and heterogeneous components (e.g., memory controllers, hardware accelerators) within a single chip. These SoCs often use a large number of voltage domains to power the heterogeneous components. Such a large number of voltage domains are often powered by a power management integrated circuit (PMIC), which provides a plurality of voltages using a plurality of off-chip voltage regulators. Unfortunately, a PMIC often uses bulky, discrete inductors and capacitors that consume a large amount of volume, which can be critical in portable electronic devices with limited available space.

Given the drawback of existing PMICs, there has been a surge of interest in building voltage regulators that use smaller discrete components or even integrated voltage regulators (IVRs) that integrate components in a single die. One of such voltage regulators includes a switching regulator.

One class of a switching regulator includes a switched-inductor (SI) regulator, such as a buck regulator, a boost regulator, a flying buck regulator, or a flipped flying buck regulator disclosed in U.S. Utility patent application Ser. No. 14/250,970, titled "APPARATUS, SYSTEMS, AND METHODS FOR PROVIDING A HYBRID POWER REGULATOR," by Le et al., filed on Apr. 11, 2014, which is herein incorporated by reference in its entirety. FIGS. 1A-1B illustrate a step-down switched-inductor (SI) regulator and its operation. The SI regulator can convert a high voltage to a lower voltage. As illustrated in FIG. 1A, the SI regulator 100 can include an inductor 108 and two switches 114, 116. The SI regulator 100 can connect a first terminal of the inductor 108 to one of (1) a first voltage source  $V_{IN}$

6

104 and (2) a second voltage source 118 through a set of power switches 114, 116. In some cases, the second voltage source 118 can include, but is not limited to, a ground voltage source. The power switches 114, 116 can be turned on and off using external inputs. In some cases, the power switches 114, 116 can be controlled so that the two switches are not turned on at the same time. The power switches 114, 116 can include transistors. The transistors can include a metal-oxide-semiconductor field-effect transistor (MOSFET). For example, the switch 114 can include a P-channel MOSFET transistor; the switch 116 can include an N-channel MOSFET transistor.

FIG. 1B illustrates a signal diagram of the switched-inductor regulator in FIG. 1A. As the power switches 114, 116 turn on and off with a period T, the input of the inductor  $V_X$  102 can swing between 0 and  $V_{IN}$  with a period T. The inductor 108 and capacitor 120 operate as a low-pass filter that averages  $V_X$  102 over time, thereby creating a signal at the regulator output  $V_{OUT}$  110 with a small voltage ripple. The output voltage  $V_{OUT}$  110 can depend on the amount of time the inductor 108 is coupled to the first voltage source  $V_{IN}$  104 and the amount of time the inductor 108 is coupled to the second voltage source 118. For example, the SI regulator 100 can adjust the level of  $V_{OUT}$  110 to  $V_{IN}D+(0V)$  (1-D), where D, a number between 0 and 1, is the portion of time  $V_X$  is coupled to  $V_{IN}$ . D is also referred to as a duty cycle. The output load that consumes the current 106 can be any type of an electronic device, including one or more of processors, memory (DRAM, NAND flash), RF chips, WiFi combo chips, and power amplifiers.

A power efficiency of the SI regulator 100 can be computed as:

$$\eta = \frac{P_L}{P_O}$$

where  $P_L$  indicates the power delivered to the output load 106 and  $P_O$  indicates the output power of the SI regulator 100.  $P_L$  can be computed as follows:  $P_L = P_O - P_{LOSS}$ , where  $P_{LOSS}$  includes the amount of power losses during the voltage regulation process.

One of the major power losses  $P_{LOSS}$  associated with a SI regulator 100 includes a resistive power loss incurred by the parasitic resistance of the inductor 108. When the SI regulator 100 delivers power to the output load 106 by providing current 112, ideally, the SI regulator 100 provides all of its output power to the output load 106. In this ideal configuration, the inductor 108 has zero resistance, and, therefore, the current through the inductor 108 would not dissipate any power. However, in a practical scenario, the SI regulator 100 dissipates some of its output power internally at the inductor 108, primarily due to the resistance of the material forming the inductor 108. This undesirable, finite resistance of the inductor 108 is referred to as a parasitic resistance of the inductor 108. The parasitic resistance can incur a resistive power loss since the parasitic resistance can cause the current through the inductor 108 to dissipate energy. Therefore, the resistive power loss can reduce the power conversion efficiency of the SI regulator 100.

When the current alternates with a predetermined period T, then the resistive power loss can be computed as  $P_R = I_{L,RMS}^2 R_L$ , where  $R_L$  is the value of the parasitic resistance of the inductor 108, and  $I_{L,RMS}$  is the root-mean square of the current through the inductor 108.  $I_{L,RMS}$  can be reduced by reducing the peak-to-peak ripple of the inductor current



( $I_{L,PP}$  120). Therefore, the SI regulator 100 can reduce the resistive loss  $P_R$  by reducing the peak-to-peak ripple of the inductor current  $I_{L,PP}$  120.

There are two ways to reduce the peak-to-peak ripple of the inductor current  $I_{L,PP}$  120. First the SI regulator 100 can be operated at a high frequency and reduce the period  $T$  of the SI regulator 100. However, the solution can increase the power consumed to charge and discharge the parasitic capacitance at the junction 122 between switches 114, 116. This capacitive power loss can be significant because the size of the switches 114, 116 can be large, which increases the parasitic capacitance, and because the voltage swing on  $V_X$  102 is large (e.g.,  $0V \sim V_{IN}$ ). This capacitive power loss can be computed as follows:  $P_C = fCV^2$ , where  $C$  is the amount of the parasitic capacitance at the junction 122,  $f$  is the frequency at which the SI regulator 100 switches, and  $V$  is the voltage swing at the junction 122.

Second, the SI regulator 100 can use an inductor 108 with a high inductance value. However, this approach makes the inductor 108 occupy a large volume, which can be problematic in many electronic devices, including portable electronic devices.

Another class of a switching regulator includes a switched-capacitor (SC) regulator. An SC regulator can use one or more capacitors, instead of inductors, to transfer charge from a power source  $V_{IN}$  to an output load  $V_{OUT}$ . An SC regulator can use power switches to couple or decouple one or more capacitors to one of multiple voltages over a period of time, thereby providing an output voltage that is a weighted average of the multiple voltages. The SC regulator can control the output voltage by changing the configuration and the sequence in which capacitors are coupled to one another. Oftentimes, it is easier to implement an SC regulator with a small form factor compared to implementing an SI regulator because capacitors generally have a higher quality (e.g., lower series resistance) compared with inductors, particularly in integrated implementations.

Unfortunately, efficiencies of SC regulators can degrade at output voltages that are not a predetermined fraction of the input voltage. For example, an SC regulator can achieve high efficiencies at  $\frac{1}{2}$ ,  $\frac{1}{3}$ ,  $\frac{2}{3}$ ,  $\frac{2}{5}$ ,  $\frac{3}{5}$  of the input voltage. However, the same SC regulator can fail to provide high efficiencies when the output voltage deviates from those values. This is a problem for many SoCs that operate within a continuous range of voltages, or a range of voltages in 5-10 mV steps.

Some of the challenges associated with the SI regulator and the SC regulator can be addressed using a hybrid regulator. The hybrid regulator can include both the SC regulator and the SI regulator in series. The hybrid regulator topology can maintain high efficiency across a wide output and input voltage range, even with small inductors and capacitors. The hybrid regulator topology can include two types of regulators: an SI regulator and an SC regulator that divides or boosts the input voltage into an  $M/N$  fraction of the input voltage, where  $M$  and  $N$  can be any number greater than zero. This approach can reduce the resistive loss of the switched inductor regulator even with a small inductor with a low inductance. Furthermore, the hybrid regulator topology can reduce the capacitive loss ( $CV^2f$  loss) of the switched inductor regulator by limiting the voltage swing across the switches.

FIG. 2A illustrates a hybrid regulator topology in accordance with some embodiments. FIG. 2A includes a hybrid regulator 200 that includes two or more voltage converter stages 206, 208, 210 connected in series (in this disclosure, the term voltage converter stage is used interchangeably

with a voltage regulator, a regulator, a voltage converter, and a converter), where each voltage converter stage can include a voltage regulator (also known as a voltage converter). The voltage regulator can include an SI regulator or an SC regulator, comprising one or more switches connecting/disconnecting one or more inductors or one or more capacitors, respectively. A typical inductance of the inductor in the SI regulator can range from 100 pico-Henry to 5 micro-Henry and power switches in the SI regulator can typically have width/(minimum length) values of 1000 to 100,000. For example, in a 90 nm process technology, power switch widths typically range from 100  $\mu\text{m}$  to 10 mm. Switching frequencies typically range from 1 MHz to 500 MHz.

In some embodiments, an SC regulator can include an  $N:M$  step-down voltage regulator 216, as illustrated in FIG. 2B. The  $N:M$  regulator 216 is configured to reduce a received voltage  $V_{IN,SC}$  212 to  $(M/N)V_{IN,SC}$  to generate the output  $V_{IN,SC}$  214. Some examples of  $N:M$  include 1:1, 2:1, 3:1, 3:2, 4:1, 4:3, 5:1, 5:2, 5:3, 5:4, 6:5, 7:1, 7:2, 7:3, 7:4, 7:5, 7:6, or any other suitable fractions. The fraction  $N:M$  can be determined based on the configuration of capacitors and switches during the voltage regulation process. The configuration of capacitors and switches can be reconfigured during the voltage regulation process to dynamically change the fraction  $N:M$  to different values (e.g.,  $(N-1):M$ ,  $(N-2):M$ ,  $N:(M-1)$ ,  $N:(M-2)$ ,  $(N-1):(M-1)$ , etc.).

FIGS. 3A-3B illustrates a hybrid regulator that includes an SC regulator and an SI regulator connected in series. FIG. 3A includes an SC regulator 322 and an SI regulator 100. The SC regulator 322 can convert the input voltage  $V_{IN}$  104 to  $V_{TMP}$  324. Then the SI regulator 100 can receive  $V_{TMP}$  324 and regulate it to provide  $V_{OUT}$  310 in fine steps using multiple power switches 114, 116 and one or more inductors 108. FIG. 3B illustrates the timing diagram of signals in the regulator.

This hybrid regulator hinges on the fact that SC regulators are good at dividing voltages across predetermined fractional values and that SI regulators are good at regulating across a wide range of conversion ratios of output voltage and input voltage, in fine steps. For example, in a 12V-to-1V step-down regulator, the SC regulator 322 can receive 12V at  $V_{IN}$  104 and provide a  $1/6$  step-down, thereby providing 2V at  $V_{TMP}$  324. Subsequently, the SI regulator 100 can provide a subsequent regulation to regulate 2V to 1V. Since this regulator reduces the voltage swing at  $V_X$  302 to  $V_{TMP}$  324, which can be substantially less than  $V_{IN}$  104, this regulator can reduce the capacitive power loss due to the parasitic capacitance at the junction 122.

A hybrid regulator, like any other voltage regulators, is coupled to a control system that controls the output voltage of the hybrid regulator. The control system can include a feedback system that controls the hybrid regulator so that the output voltage is within the tolerable error range from the target output voltage.

Designing a feedback system for a hybrid regulator can be challenging, even compared to traditional regulators, because there can be a large number of regulators in the hybrid regulator. One challenge unique to controlling a hybrid regulator is that the control system has to balance the current being delivered at each stage of the hybrid regulator. FIG. 4 illustrates a two-stage hybrid regulator in accordance with some embodiments. If the current  $I_1$  412, being delivered through Converter 1 408, is smaller than the current  $I_2$  414 being delivered through Converter 2 410, the output voltage  $V_{TMP}$  406 of Converter 1 408 can keep decreasing and cause a large voltage across Converter 1 408 (i.e.,  $V_{IN} - V_{TMP}$ ) and small voltage across Converter 2 410 (i.e.,



$V_{TMP}-V_{OUT}$ ). Depending on the intended operating voltage range of the two converter stages **408**, **410**, both converters can malfunction if  $V_{TMP}$  **406** deviates too much from its intended value. On the other hand, if  $I_1$  **412** is larger than  $I_2$  **414**,  $V_{TMP}$  **406** can keep increasing and can make both converter stages **408**, **410** malfunction. Therefore, the control system has to control both Converter **1** and Converter **2** **408**, **410** in order to balance the currents  $I_1$  **412** and  $I_2$  **414**. The control system could balance the current across multiple converter stages using a separate feedback system for each converter stage. However, as the number of converters in the hybrid regulator increases, the control system can quickly become very complex.

This disclosure introduces apparatus, systems, and methods for providing a hybrid regulator having a simple feedback system that is capable of balancing current across a plurality of converter stages in the hybrid regulator. The disclosed feedback system can balance the current delivered across multiple converter stages without having a separate feedback system dedicated to each converter stage in the hybrid regulator. To this end, each converter stage in the hybrid regulator can be configured to operate in a mode in which the disclosed feedback system can control the operating frequency of the converter stage to control the amount of current provided by the converter stage.

In some embodiments, the hybrid regulator can include a plurality of converter stages, which may include one or more SC converters. In some cases, the output current of the SC converter (e.g., an amount of charge delivered to the output node per unit time) can depend on its operating frequency. For example, as illustrated with respect to FIG. **5A**, an SC converter is configured to provide a fixed amount of charge (also referred to as a charge packet or a packet) to an output node within a switching period. Therefore, the output current of the SC converter can be increased with a higher operating frequency (e.g., a shorter switching period); the output current of the SC converter can be reduced with a lower operating frequency (e.g., a longer switching period). In some embodiments, the amount of charge provided to the output by the SC converter can depend on (1) an amount of charge in the charge packet and (2) an operating frequency of the converter (i.e., a frequency at which the charge packet is provided to the output.) In some embodiments, the amount of charge provided to the output by the SC converter is a multiplication of (1) an amount of charge in the charge packet and (2) an operating frequency of the converter (i.e., a frequency at which the charge packet is provided to the output.)

In some embodiments, the SI converter can also be configured so that its output current depends on its operating frequency. For example, the SI converter can be configured to operate in a discontinuous conduction mode (DCM). The DCM refers to an operating mode of an SI converter in which current is delivered to an output in a discontinuous manner. In the DCM, the SI converter can deliver a fixed amount of charge (also referred to as a charge packet or a packet) to an output node within a switching period. For example, the SI converter can deliver a non-zero amount of charge for a first portion of the switching period and deliver zero amount of charge in a second portion of the switching period until the next cycle. Therefore, the SI converter can increase the operating frequency (e.g., reduce the switching period) to deliver more charge (e.g., more current) to the output node or decrease the operating frequency to deliver less charge (e.g., less current) to the output node. In some embodiments, the amount of charge provided to the output by the SI converter in a DCM can depend on (1) an amount

of charge in the charge packet and (2) an operating frequency of the converter (i.e., a frequency at which the charge packet is provided to the output.) In some embodiments, the amount of charge provided to the output by the SI converter in a DCM is a multiplication of (1) an amount of charge in the charge packet and (2) an operating frequency of the converter (i.e., a frequency at which the charge packet is provided to the output.)

When all SI converters in a hybrid regulator operates in a DCM, the feedback system of the hybrid regulator can control the operating frequency of converter stages in the hybrid regulator to balance the amount of current provided by each converter stage. As discussed above, the amount of charge provided to the output by the SI converter in a DCM or the SC converter can depend on (1) an amount of charge in the charge packet and (2) an operating frequency of the converter (i.e., a frequency at which the charge packet is provided to the output). Therefore, if the amount of charge in a charge packet of each converter stage is known in advance, then the feedback system can control the operating frequency of the converters to balance the amount of current provided by each converter stage.

For example, if the amount of charge in the charge packet is identical across the converter stages, then the feedback system can provide the same operating frequency to all converter stages to balance the current across the converter stages. As another example, consider a hybrid regulator with four regulators, and the amount of charge per charge packet in each regulator is 1, 2, 3, and 4, respectively. To balance charge across the four converter stages, the feedback system can determine an operating frequency of the four converter stages so that a multiplication of the operating frequency and the charge per packet is identical across the four converter stages. Therefore, the feedback system can determine that the operating frequencies in the four converter stages should be  $12f$ ,  $6f$ ,  $4f$ , and  $3f$ , where  $f$  is a scale factor.

In some embodiments, the feedback system can change the operating frequency of converter stages to change the amount of current provided by the hybrid regulator to the output load. If the output load needs more current than the currently provided amount of current, the feedback system can simply increase the operating frequency of the converters; if the output load needs less current than the currently provided amount of current, the feedback system can decrease the operating frequency of the converters. Referring back to the example above, the feedback system can control the operating frequency of the four converter stages by controlling the value of the single scale factor  $f$ . For instance, the feedback system can increase “ $f$ ” when the output load needs more current; the feedback system can decrease “ $f$ ” when the output load needs less current. Since the feedback system can control an amount of output current by changing only a single scale factor  $f$ , the feedback system can be very simple.

FIG. **5A** illustrates a charge transfer operation of an SC regulator in accordance with some embodiments. In some embodiments, the operation of the SC regulator mimics the DCM. For example, when the switching frequency is low enough compared to a time constant of the SC regulator, the output current provided by the SC regulator can be close to zero by the end of the switching cycle (e.g., a beginning of the next switching cycle). As illustrated in FIG. **5A**, an SC regulator can deliver a non-zero amount of charge **502** during a first portion of the switching period  $T_{SWITCH}$  **512** and deliver a close-to-zero amount of charge during a second portion of the switching period  $T_{SWITCH}$  **512**. This charge transfer operation can be repeated every switching period



$T_{SWITCH}$  512, as illustrated by another charge packet 504. Therefore, the amount of charge provided by the SC regulator can be controlled by controlling the switching period (i.e., the operating frequency).

FIGS. 5B-5C illustrate a charge transfer operation of an SI regulator in accordance with some embodiments. An SI regulator can operate in one of two modes: a DCM and a continuous conduction mode (CCM). FIG. 5B illustrates the charge transfer operation of an SI regulator in the DCM; FIG. 5C illustrates the charge transfer operation of an SI regulator in the CCM. In a DCM (FIG. 5B), the SI regulator can deliver a non-zero amount of charge 510 through the inductor during a first portion of the predetermined period  $T_{SWITCH}$  512 and deliver zero amount of charge during a second portion of the predetermined period  $T_{SWITCH}$  512. This charge transfer operation can be repeated every predetermined period  $T_{SWITCH}$  512, as illustrated by another charge packet 508. On the other hand, in a CCM (FIG. 5C), the SI regulator can deliver a non-zero amount of charge through the inductor throughout the entire predetermined period  $T_{SWITCH}$  512 and the current through the inductor does not stay at 0 A.

In some embodiments, the SI regulator can operate in the DCM mode to allow a feedback system to control the amount of output charge of the SI regulator simply by controlling an operating frequency of the SI regulator. The amount of charge delivered in FIGS. 5B-5C can be computed as  $Q = \int I dt$ , where  $I$  refers to an amount of output current provided by a regulator. For the SI regulator operating in a DCM, the charge is delivered in discrete packets 508, 510, and a predetermined number of packets (e.g., one packet) is delivered every switching period  $T_{SWITCH}$  512. Therefore, the feedback system can control the amount of charge delivered to the output of the SI regulator by changing the switching period  $T_{SWITCH}$  512 of the SI regulator.

In contrast, for an SI regulator operating in a CCM, the charge is delivered continuously. In this case, changing the switching period  $T_{SWITCH}$  512 does not change the amount of charge delivered to the output. For example, as illustrated in FIG. 5D, even when the operating frequency of an SI regulator operating in a CCM is doubled, the amount of charge delivered by the SI regulator to the output remains the same. As a result, for an SI regulator operating in a CCM, the feedback control cannot change the switching frequency to control the amount of charge delivered to the output. Thus, in some embodiments, the SI regulator can operate in a DCM in order to allow the feedback system to control the output current simply by controlling an operating frequency of the SI regulator.

When an SI regulator is operating in a DCM, it can control the shape of the charge packet 510 by adjusting the rise and fall time of the output current. These times are determined by  $I_L = 1/L \int V_L dt$ , where  $L$  is the inductance value of the inductor,  $I_L$  is the inductor current, and  $V_L$  is the voltage applied across the inductor. When there is a constant positive voltage applied across the inductor (e.g., in a buck converter, the voltage of an inductor node coupled to the switches is higher than the voltage of an inductor node coupled to the output), the inductor current increases linearly, which becomes the rising slope of the triangular charge packet 510. When there is a constant negative voltage applied across the inductor (e.g., in a buck converter, the voltage of an inductor node coupled to the switches is lower than the voltage of an inductor node coupled to the output), the inductor current decreases linearly, which becomes the falling slope of the triangular charge packet 510. The shape of the charge packet 510 and amount of charge per packet can be determined by

adjusting the voltage applied across the inductor and the time period of applying positive and negative voltages across the inductor.

FIG. 6A illustrates a hybrid regulator system in accordance with some embodiments. The hybrid regulator system includes a hybrid regulator 400 having a 1<sup>st</sup> stage SI regulator 408 and a 2<sup>nd</sup> stage SC regulator 410, and a feedback system 637. In some embodiments, one or more of the SI regulator 408 and SC regulators 410 can be a single-phase regulator. In other embodiments, one or more of the SI regulator 408 and SC regulators 410 can be a multi-phase regulator having a plurality of regulator cells, where each regulator cell includes circuit elements that can independently convert an input voltage to an output voltage. The number of regulator cells in a multi-phase regulator can be equivalent to the number of phases provided by the multi-phase regulator.  $N_{PH\_SI}$  and  $N_{PH\_SC}$  indicate the number of phases of the SI regulator and the SC regulator, respectively, where  $N_{PH\_SI}$  and  $N_{PH\_SC}$  can be any number from larger or equal to 1 with typical values ranging from 1 to 100. The regulator cells can be independently operated by clock signals that are out-of-phase from one another. For example, a first regulator of the multi-phase regulator cell can receive a first clock signal and a second regulator cell of the multi-phase regulator can receive a second clock signal, where the first clock signal and the second clock signal have the same frequency and are out of phase, for instance, by 180 degrees.

The feedback system 637 can include one or more of a feedback control 620, a frequency modifier 639, and, in case the regulators in the hybrid regulator are multi-phase, multiphase signal generators 632, 634. The frequency modifier 639 can include a frequency divider that receives a first periodic signal having a first frequency and generates a second periodic signal having a second frequency. The frequency divider can include a regenerative frequency divider, an injection-locked frequency divider, a digital divider, or a sigma-delta fractional-N synthesizer. The frequency modifier 639 can be configured to receive an input periodic signal and provide an output periodic signal. The frequency of the output periodic signal can be a fractional multiple of the frequency of the input periodic signal. For example, the frequency of the output periodic signal can be 1/2 of the frequency of the input periodic signal; the frequency of the output periodic signal can be 3/5 of the frequency of the input periodic signal; the frequency of the output periodic signal can be 7/5 of the frequency of the input periodic signal; the frequency of the output periodic signal can be identical to the frequency of the input periodic signal; or the frequency of the output periodic signal can be twice the frequency of the input periodic signal.

FIG. 6B illustrates a flow diagram that illustrates an operation of the hybrid regulator system of FIG. 6A in accordance with some embodiments. In step 640, a comparator 636 can determine whether  $V_{OUT}$  604 is larger or smaller than  $V_{REF}$  618, which is the target output voltage  $V_{TARGET}$  of the hybrid regulator. In steps 642/644, based on the result of the comparison in step 640, the feedback control block 620 can adjust the frequency of  $V_{CTRL}$  628, where  $V_{CTRL}$  628 is a clock signal that determines the operating frequencies of the SI regulator 408 and SC regulator 410. If  $V_{OUT}$  604 is larger than  $V_{REF}$  618, the feedback control block 620 decreases the frequency of  $V_{CTRL}$  628. If  $V_{OUT}$  604 is smaller than  $V_{REF}$  618, the feedback control block 620 increases the frequency of  $V_{CTRL}$  628. The feedback control block 620 can implement a linear control scheme, a non-linear control scheme, a lower-bound control scheme, a



proportional-integral-derivative ((PID) control scheme, or any other suitable control schemes for controlling the hybrid regulator. The feedback control block **620** can include an oscillator, such as a voltage controlled oscillator, that is configured to generate a periodic signal based on the difference between the  $V_{OUT}$  **604** and the  $V_{REF}$  **618**.

In step **652**, the frequency divider **639** can receive  $V_{CTRL}$  **628** and generate  $V_{CTRL\_DIV}$  **622**, which is a frequency divided version of  $V_{CTRL}$  **628** having a different frequency compared to  $V_{CTRL}$  **628**. In some embodiments, where the SC regulator **410** and SI regulator **408** can operate at the same frequencies (i.e., an amount of charge in the charge packet of the SI regulator is identical to an amount of charge in the charge packet of the SC regulator), the frequency divider **639** can be removed from the feedback system **637**, in which case  $V_{CTRL\_DIV}$  **622** is identical to  $V_{CTRL}$  **628**.

In step **646**, based on the clock signals  $V_{CTRL}$  **628** and  $V_{CTRL\_DIV}$  **622**, multi-phase generators **632**, **634** can generate interleaved signals  $CLK_{SI}[N_{PH\_SI}-1:0]$  **626** and  $CLK_{SC}[N_{PH\_SC}-1:0]$  **624** that drive multiple phases of the SI regulator **408** and SC regulator **410**, respectively. In some embodiments, where the SC regulator **410** and the SI regulator **408** are single-phase regulators, the multi-phase generator blocks **632** **634** can be removed, and the method steps **646** and **648** can be skipped.

In step **648**, based on  $CLK_{SI}[N_{PH\_SI}-1:0]$  **626**, the SI regulator **408** can deliver charge packets to the 2<sup>nd</sup> stage SC regulator via the node  $V_{IN\_N:M}$  **602**, which is the input of the 2<sup>nd</sup> stage SC regulator **410**. In step **650**, the 2<sup>nd</sup> stage SC regulator **410** can receive charges from the SI regulator **408** and switches the capacitors in the SC regulator **410** based on  $CLK_{SC}[N_{PH\_SC}-1:0]$  **624** to deliver current to the output  $V_{OUT}$  **604**, which is sent to the comparator **636** to go back to the first step **640**. If the charge per packet and switching frequencies of the SI regulator **408** and SC regulator **410** are identical, the charge delivered by the two regulators **410**, **408** can be balanced and  $V_{IN\_N:M}$  **602** can stay at a predetermined value.

Following these steps, the feedback can regulate the output voltage  $V_{OUT}$  **604** to be within a tolerance range of the reference voltage  $V_{REF}$  **618**. The tolerance range of the hybrid regulator can be predetermined. The tolerance range of the hybrid regulator can be  $\pm 0.1-5\%$  of the target voltage in steady state and  $\pm 5-20\%$  during load transient events when the load current fluctuates. If the output voltage  $V_{OUT}$  **604** drops below the reference voltage  $V_{REF}$  **618** due to a surge in load current **616**, the feedback system increases the operating frequencies of the SI regulator **408** and SC regulator **410** to increase the amount of current provided to the output  $V_{OUT}$  **604** to increase  $V_{OUT}$  **604**. As discussed above, the increase in the operating frequencies of the converter stages increases the delivered current because charge packets, having a fixed amount of charge, are delivered to the output more frequently. On the other hand, if the output voltage  $V_{OUT}$  **604** spikes over the reference voltage  $V_{REF}$  **618** due to a drop in load current **616**, the feedback system decreases the operating frequencies of the SI regulator **408** and SC regulator **410** to reduce the current provided to the output  $V_{OUT}$  **604**.

FIG. **6C** shows a signal diagram that illustrates how the feedback system regulates the output voltage in accordance with some embodiments. For this particular illustration, the number of phases in the SI regulator **408** ( $N_{PH\_SI}$ ) is 2; the number of phase in the SC regulator **410** ( $N_{PH\_SC}$ ) is 4; and the ratio of operating frequencies of the SI regulator **408** and the SC regulator **410** ( $N_{FREQ}:M_{FREQ}$ ) is 1:1. Since  $N_{FREQ}$ :

$M_{FREQ}$  is 1:1, FIG. **6C** illustrates a scenario in which the feedback system does not include the frequency divider block **639**.

As provided in the previous paragraph,  $V_{CTRL}$  **628** is a clock signal with a frequency set by the feedback control block **620**. The multi-phase generator blocks **632**, **634** generate clock signals  $CLK_{SI}[N_{PH\_SI}-1:0]$  **626** and  $CLK_{SC}[N_{PH\_SC}-1:0]$  **624** that are interleaved by 180 degrees and 90 degrees, respectively, based on  $V_{CTRL}$  **628**.

At time  $t_1$  **630**,  $V_{CTRL}$  **628** has a first rising edge, which triggers  $CLK_{SI}[0]$  **626** and  $CLK_{SC}[0]$  **624**. These are signals that control the phases of SI regulator **408** and SC regulator **410**, respectively. When  $CLK_{SI}[0]$  **626** is triggered, the first phase of the SI regulator **408** switches to deliver a packet of charge, creating a triangular waveform on  $I_L[0]$  **610**.

At time  $t_2$  **632**,  $V_{CTRL}$  **628** has a second rising edge, which triggers the signals  $CLK_{SI}[1]$  **626** and  $CLK_{SC}[1]$  **624** that control the second phases of the SI regulator **408** and SC regulator **410**, respectively.  $CLK_{SI}[1]$  **626** is 180 degrees out of phase from  $CLK_{SI}[0]$  **626** and  $CLK_{SC}[1]$  **624** is 90 degrees out of phase from  $CLK_{SC}[0]$  **624**. Controlled by  $CLK_{SI}[1]$  **626**, the second phase of the SI regulator **408** switches to deliver a packet of charge, creating a triangular waveform on  $I_L[1]$  **610**.

At time  $t_3$  **634**,  $V_{CTRL}$  **628** has a third rising edge, which triggers signals  $CLK_{SI}[0]$  **626** and  $CLK_{SC}[2]$  **624** that control the first phase of the SI regulator **408** and the third phase of the SC regulator **410**, respectively. Note that since the SI regulator **408** only has 2 phases, it has now come back to the first phase and delivers a charge packet through  $I_L[0]$  **610**.

At time  $t_4$  **636**,  $V_{CTRL}$  **628** has a fourth rising edge, which triggers signals  $CLK_{SI}[1]$  **626** and  $CLK_{SC}[3]$  **624** that control the second phase of the SI regulator **408** and the fourth phase of the SC regulator **410**, respectively. From time  $t_5$  **638**, the feedback system repeats the process of time instances  $t_1-t_4$ .

In some embodiments, the first converter stage of the hybrid regulator can include an SI regulator and the second converter stage of the hybrid regulator can include an SC regulator. In other embodiments, the first converter stage of the hybrid regulator can include an SC regulator and the second converter stage of the hybrid regulator can include an SI regulator.

In some embodiments, in addition to the feedback system that balances the delivered charge across all converter stages to regulate the output voltage, the hybrid regulator system can include another feedback system that is configured to operate the SC regulator **410** at a configuration at which the SC regulator **410** can achieve a high efficiency.

In ideal cases, the SC regulator **410** is able to step down the input voltage  $V_{IN\_N:M}$  **602** to an output voltage  $V_{OUT}$  **604**, where the value of the output voltage  $V_{OUT}$  **604** is

$$\frac{M}{N} V_{IN\_N:M}$$

However, in practice, the output voltage  $V_{OUT}$  **604** can be limited to

$$\frac{M}{N} V_{IN\_N:M} - V_{SC\_DROP}$$

(i.e., the maximum output voltage of the SC regulator **410** is limited to

$$\left. \frac{M}{N} V_{IN:N:M} - V_{SC\_DROP} \right\},$$

where  $V_{SC\_DROP}$  is a parasitic voltage drop caused by various non-ideal effects, such as a parasitic resistance of switches. Oftentimes  $V_{SC\_DROP}$  can be substantially small compared to the output voltage  $V_{OUT}$  **604** (e.g., 0-200 mV in a 90 nm process).

The control system of the SC regulator **410** can anticipate that the output voltage of the SC regulator **410** cannot be exactly

$$\frac{M}{N} V_{IN:N:M}.$$

Therefore, instead, the controls system of the SC regulator **410** can set the target output voltage **604** of the SC regulator as

$$V_{TARGET} = \frac{M}{N} V_{IN:N:M} - V_{T\_DROP},$$

where  $V_{T\_DROP}$  is the target voltage drop.

As  $V_{T\_DROP}$  is set to a value close to 0V, it becomes increasingly difficult for the SC regulator to match the target output voltage  $V_{TARGET}$  because the actual voltage drop  $V_{SC\_DROP}$  can be greater than the target voltage drop  $V_{T\_DROP}$ , in which case the maximum output voltage of the SC regulator

$$\left( \text{i.e., } \frac{M}{N} V_{IN:N:M} - V_{SC\_DROP} \right)$$

can be less than the target output voltage

$$V_{TARGET} = \frac{M}{N} V_{IN:N:M} - V_{T\_DROP}.$$

For example, consider a case where the SC regulator is a 2:1 regulator and the input voltage  $V_{IN:N:M}$  is 2V. Ideally, the output voltage  $V_{OUT}$  can be 1V and the parasitic voltage drop  $V_{SC\_DROP}$  can be 0V. However, if the parasitic resistance of switches is 0.1Ω and the load current is 1 A, the parasitic voltage drop from the parasitic resistance is 0.1V. Therefore, the maximum output voltage of the SC regulator is 0.9V. In this case, unless the target voltage drop  $V_{T\_DROP}$  is equal to or higher than 0.1V, the SC regulator cannot match the target voltage  $V_{TARGET}$ . This problem becomes more pronounced as the parasitic resistance increases or the load current increases. As a result, when target voltage drop  $V_{T\_DROP}$  is set at a large value, it becomes easier to guarantee a proper regulation of the output voltage across a wide range of parasitic values and load current. On the other hand, the efficiency of the SC regulator degrades as the target voltage drop  $V_{T\_DROP}$  increases as the output  $V_{OUT}$  **604** deviates from

$$\frac{M}{N} V_{IN:N:M}.$$

Therefore, there is a trade-off between ease of regulation and conversion efficiency. Thus, it is desirable to set the target voltage drop  $V_{T\_DROP}$  so that it is large enough to regulate the output properly while small enough to reduce efficiency degradation. The second feedback system of the hybrid regulator can be configured to set the target voltage drop  $V_{T\_DROP}$  so that it is large enough to regulate the output properly while small enough to reduce efficiency degradation.

FIG. 7A illustrates a hybrid regulator system having a second feedback system in accordance with some embodiments. Compared to FIG. 6A, the hybrid regulator system includes, in addition to the hybrid regulator **400** and the first feedback system **637**, a second feedback system **768** that adjusts parameters of the SI regulator **408** to increase the regulator efficiency **768**.

The goal of the second feedback system **768** is to keep the parasitic voltage drop  $V_{SC\_DROP}$  **746** within a tolerance range of the target voltage drop  $V_{T\_DROP}$  **744**, which is typically 0 to 0.2V, to increase the SC regulator efficiency. Since the conversion ratio of the SC regulator (i.e., N and M) is known and  $V_{OUT}$  **604** is regulated by the first feedback system, the second feedback system **768** can control  $V_{SC\_DROP}$  **746** of the SC regulator **410** by adjusting  $V_{IN:N:M}$  **602**.

To adjust  $V_{IN:N:M}$  **602**, the second feedback system **768** can control an amount of current provided to the input of the SC regulator **410**. The second feedback system **768** can control an amount of current provided to the input of the SC regulator **410** by adjusting parameters of the SI regulator **408**.

FIG. 7B illustrates parameters of the SI regulator **408** adjusted by the second feedback system **768** in accordance with some embodiments. The adjusted parameters of the SI regulator **408** can include a switching period  $T_{SI}$  **752** (or  $\text{Freq}_{SI}$  **756**, which is equal to

$$\left. \frac{1}{T_{SI}} \right\},$$

which controls an operating frequency of the SI regulator **408**; an active period  $T_{ACTIVE}$  **748**, which indicates a portion of  $T_{SI}$  **752** during which the SI regulator provides current to the SC regulator; and a duty cycle D **754** that defines a portion of the active period  $T_{ACTIVE}$  **748** during which the SI regulator increases the current provided to the SC regulator. To increase  $V_{IN:N:M}$  **602**, the second feedback system **768** can cause the SI regulator **408** to deliver more charge to  $V_{IN:N:M}$  **602** by increasing  $T_{ACTIVE}$  **748**, duty cycle D **754**, and/or  $\text{Freq}_{SI}$  **756**. To decrease  $V_{IN:N:M}$  **602**, the second feedback system **768** can cause the SI regulator **408** to deliver less charge to  $V_{IN:N:M}$  **602** by decreasing  $T_{ACTIVE}$  **748**, duty cycle D **754**, and/or  $\text{Freq}_{SI}$  **756**.

In some embodiments, the second feedback system **768** can control the duty cycle D **754** using a zero current sense block **772**. The zero current sense block **772** can be configured to sense a time instance at which the inductor current of the SI regulator  $I_L$  **710** reaches 0 A, and at that time instance, the zero current sense block **772** can be further configured to prevent the inductor current from flowing through the inductor by disconnecting the inductor from one or more nodes that provide current to the inductor. In some embodiments, the zero current sense block **772** can include (1) a resistor in series with the inductor and (2) a voltage comparator that detects a voltage induced by the inductor



current across the resistor. In such embodiments, the resistor can be the inherent resistive component (e.g., equivalent series resistance (ESR)) of the inductor. In other embodiments, the resistor can have a low resistance in order to reduce power dissipation across the resistor. Other types of zero current sense block **772**, which are readily available to a person of ordinary skill in the art, are also contemplated.

FIG. 7C illustrates a flow diagram of the hybrid regulator and the second feedback system. The flow diagram describes how the second feedback control system **768** controls  $V_{SC\_DROP}$  **746** to increase the efficiency of the hybrid regulator.

In step **772**, the comparator **764** in the second feedback system **768** determines whether  $V_{SC\_DROP}$  **746** is larger or smaller than  $V_{T\_DROP}$  **744**, which is the target value of  $V_{SC\_DROP}$  **746** predetermined by the hybrid regulator. Subsequently, based on the result of the comparison, the SC drop control block **742** adjusts  $T_{ACTIVE}$  **748**, duty cycle **D 754**, and/or  $Freq_{SI}$  **756**. For example, if  $V_{SC\_DROP}$  **746** is larger than  $V_{T\_DROP}$  **744**, then, in step **774**, the SC drop control block **742** increases one or more of the three parameters— $T_{ACTIVE}$  **748**, duty cycle **D 754**, and  $Freq_{SI}$  **756**. On the other hand, if  $V_{SC\_DROP}$  **746** is smaller than  $V_{T\_DROP}$  **744**, then, in step **776**, the SC drop control block **742** decreases one or more of the three parameters— $T_{ACTIVE}$  **748**, duty cycle **D 754**, and  $Freq_{SI}$  **756**. The SC drop control block **742** can be implemented as a finite-state-machine (FSM).

In step **778**, based on the clock signals  $V_{CTRL}$  **628** and  $V_{CTRL\_DIV}$  **622**, the multi-phase generator **632** can generate interleaved signals  $CLK_{SI}[N_{PH\_SI}-1:0]$  **626** that drive multiple phases of the SI regulator **408**.

Subsequently, in step **648**, as discussed above, the SI regulator **408** delivers charge packets to  $V_{IN\_N:M}$  **602** based on  $CLK_{SI}[N_{PH\_SI}-1:0]$  **626**. In step **650**, as discussed above, the SC regulator **410** receives charge from the SI regulator **408** and switches based on  $CLK_{SC}[N_{PH\_SC}-1:0]$  **624** to deliver charge to the output  $V_{OUT}$  **604**.

In step **780**, based on  $V_{OUT}$  **604**,  $V_{IN\_N:M}$  **602** and the equation

$$V_{OUT} = \frac{M}{N} V_{IN\_N:M} - V_{SC\_DROP},$$

the SC drop measure block **770** calculates  $V_{SC\_DROP}$  **746** and provides it to the comparator **764** so that the comparator can iterate the process again from step **772**.

Although FIGS. 4-7 illustrates feedback systems for a two stage hybrid regulator, the disclosed feedback systems can be applied to any type of hybrid regulators as generally illustrated in FIG. 2.

In some embodiments, the hybrid regulator can include bypass switches coupled to one or more converter stages so that certain converters can be dynamically bypassed to improve the efficiency of the hybrid regulator. FIG. 8 illustrates a hybrid regulator with bypass switches in accordance with some embodiments. FIG. 8 includes a plurality of voltage converter stages **806**, **808**, . . . , **810**, and bypass switches **812**, **814**, . . . , **816**.

Suppose that  $V_{IN}$  **802** is 12V, the converter **1 806** is a 6:1 SC regulator and the target output  $V_{OUT}$  **804** is 1.9V. Recall that

$$V_{OUT} = \frac{M}{N} V_{IN\_N:M} - V_{SC\_DROP},$$

where  $V_{IN\_N:M}$  is the input and  $V_{OUT}$  is the output of an SC regulator. The output of converter **1 818** can be a value very close to 12V divided by 6, which is 2V. Assuming  $V_{SC\_DROP}$  is 0.1V, which is acceptable for maintaining a high (i.e. up to 95%) efficiency of the SC regulator, the remaining converters (i.e., converter **2 808** and converter **N 810**) can be bypassed to directly connect the output of converter **1 818** to the output  $V_{OUT}$  **804**. In this case, the switch **812** is “off” or disconnected and the remaining switches **814 816** are “on” or connected to bypass converter **2** and converter **N**.

As another example, suppose that the target output voltage  $V_{OUT}$  **804** is 0.75V, and the input voltage  $V_{IN}$  **802** is 12V, and the converter **2 808** is a 2:1 SC regulator. One way to deliver the target output  $V_{OUT}$  **804** is to use the same 6:1 SC regulator (converter **1 818**) in the previous case. In this case,  $V_{SC\_DROP}$  becomes 1.25V since  $V_{OUT}$  **804** is 0.75V, instead of 1.9V. Because  $V_{SC\_DROP}$  is large, the conversion efficiency of the hybrid regulator degrades significantly (i.e. the efficiency is limited to 37.5%, which is 0.75/2.0). A better way is to use two converters (e.g., the converter **1** and the converter **2**) in series instead of just converter **1**. Since the converter **2 808** is a 2:1 SC regulator, the output of converter **1 818** can be 1.9V, and the output of converter **2 808** can be

$$\frac{1.9}{2} - 0.1 = 0.75 \text{ V},$$

assuming  $V_{SC\_DROP}$  of the converter **1 808** and the converter **2 818** is 0.1V. This way,  $V_{SC\_DROP}$  is limited to a small value for both the converter **1** and the converter **2**, and the conversion efficiency for both converters can be high (i.e. up to 83.8% in this example). To enable this configuration, switches **812** and **814** are “off” and the remaining switches **816** are “on” to bypass the rest of the converters except converters **1** and **2**.

In some embodiments, each converter stage can include a reconfigurable converter **822** (e.g., an SC converter that can reconfigure its step-down ratio across values such as 2:1, 3:1, 4:1, 5:1) that has multiple inputs and outputs, and one or more switch matrices **820 824** that can choose an input and an output from those multiple signals. For example, the reconfigurable converter **822** can receive, as input voltages, 4V and 6V, and provide, as output voltages, 1V and 2V. The reconfigurable converter **822** can be reconfigured across conversion ratios of 4:1, 6:1, 2:1, 3:1, depending on the desired input and output values.

In some embodiments, the control of the bypass switches **812**, **814**, **816** can be performed by a controller **818**. For example, the controller **818** can determine the status of the bypass switches **812**, **814**, **816**, for instance, whether one or more of the bypass switches are “on” or “off.” The controller **818** can determine the status of the bypass switches **812**, **814**, **816** based on one or more of:  $V_{IN}$  **802**,  $V_{OUT}$  **804**, the conversion ratios of all SC regulator stages in the hybrid regulator, and the parasitic SC voltage drops of SC converter stages in the hybrid regulator.

In some embodiments, the controller **818** can determine the status of the bypass switches **812**, **814**, **816** using a lookup table. The lookup table can list which switches should be turned on for various  $V_{IN}$  **802** and  $V_{OUT}$  **804** values. FIG. 9 illustrates the lookup table for controlling the bypass switches in accordance with some embodiments. This lookup table **902** is configured to control a hybrid regulator having 3 converter stages, where converter **1** is a 2:1 SC converter, converter **2** is a 3:1 SC converter, and



converter **3** is an SI converter, and 0V parasitic SC voltage drop. In some cases, the controller **818** can be a part of the first feedback system **637** or a part of the second feedback system **768**.

In some embodiments, the bypass switches **812**, **814**, **816** can be arranged serially, as illustrated in FIG. **8**. In some cases, each bypass switch in a serial arrangement can be configured to couple an input node and an output node of a single converter stage. In other cases, each bypass switch in a serial arrangement can be configured to couple an input node of a first converter stage and an output node of a second converter stage. For example, one bypass switch can be configured to couple an input node of the converter **1 806** and the output node of the converter **2 808**. In some embodiments, the bypass switches can be arranged as a switch matrix that collectively couples an input node of one converter stage and an output node of another converter stage. In some embodiments, the bypass switches can be arranged as a tree of switches that collectively couples an input node of one converter stage and an output node of another converter stage.

The disclosed apparatus and systems can include a computing device. FIG. **10** is a block diagram of a computing device in accordance with some embodiments. The block diagram shows a computing device **1000**, which includes a processor **1002**, memory **1004**, one or more interfaces **1006**, an accelerator **1008**, and a hybrid regulator system **400** having a plurality of converter stages, including the first stage converter **408** and the second stage converter **410**, the first feedback system **637**, and the second feedback system **768**. The computing device **1000** may include additional modules, fewer modules, or any other suitable combination of modules that perform any suitable operation or combination of operations.

The computing device **1000** can communicate with other computing devices (not shown) via the interface **1006**. The interface **1006** can be implemented in hardware to send and receive signals in a variety of mediums, such as optical, copper, and wireless, and in a number of different protocols, some of which may be non-transient.

In some embodiments, the accelerator **1008** can be implemented in hardware using an application specific integrated circuit (ASIC). The accelerator **1008** can be a part of a system on chip (SOC). In other embodiments, the accelerator **1008** can be implemented in hardware using a logic circuit, a programmable logic array (PLA), a digital signal processor (DSP), a field programmable gate array (FPGA), or any other integrated circuit. In some cases, the accelerator **1008** can be packaged in the same package as other integrated circuits.

In some embodiments, the computing device **1000** can include user equipment. The user equipment can communicate with one or more radio access networks and with wired communication networks. The user equipment can be a cellular phone having telephonic communication capabilities. The user equipment can also be a smart phone providing services such as word processing, web browsing, gaming, e-book capabilities, an operating system, and a full keyboard. The user equipment can also be a tablet computer providing network access and most of the services provided by a smart phone. The user equipment operates using an operating system such as Symbian OS, iPhone OS, RIM's Blackberry, Windows Mobile, Linux, HP WebOS, and Android. The screen might be a touch screen that is used to input data to the mobile device, in which case the screen can be used instead of the full keyboard. The user equipment can also keep global positioning coordinates, profile informa-

tion, or other location information. The user equipment can also be a wearable electronic device.

The computing device **1000** can also include any platforms capable of computations and communication. Non-limiting examples include televisions (TVs), video projectors, set-top boxes or set-top units, digital video recorders (DVR), computers, netbooks, laptops, and any other audio/visual equipment with computation capabilities. The computing device **1000** can be configured with one or more processors that process instructions and run software that may be stored in memory. The processor also communicates with the memory and interfaces to communicate with other devices. The processor can be any applicable processor such as a system-on-a-chip that combines a CPU, an application processor, and flash memory. The computing device **1000** can also provide a variety of user interfaces such as a keyboard, a touch screen, a trackball, a touch pad, and/or a mouse. The computing device **1000** may also include speakers and a display device in some embodiments. The computing device **1000** can also include a bio-medical electronic device.

It is to be understood that the disclosed subject matter is not limited in its application to the details of construction and to the arrangements of the components set forth in the following description or illustrated in the drawings. The disclosed subject matter is capable of other embodiments and of being practiced and carried out in various ways. Also, it is to be understood that the phraseology and terminology employed herein are for the purpose of description and should not be regarded as limiting.

As such, those skilled in the art will appreciate that the conception, upon which this disclosure is based, may readily be utilized as a basis for the designing of other structures, systems, methods and media for carrying out the several purposes of the disclosed subject matter. It is important, therefore, that the claims be regarded as including such equivalent constructions insofar as they do not depart from the spirit and scope of the disclosed subject matter.

Although the disclosed subject matter has been described and illustrated in the foregoing exemplary embodiments, it is understood that the present disclosure has been made only by way of example, and that numerous changes in the details of implementation of the disclosed subject matter may be made without departing from the spirit and scope of the disclosed subject matter, which is limited only by the claims which follow.

We claim:

1. A voltage regulator system comprising:

a hybrid regulator configured to convert an input voltage to an output voltage, wherein the hybrid regulator comprises a plurality of voltage regulators including at least a switched-inductor regulator and a switched-capacitor regulator,

wherein the switched-inductor regulator is configured to provide a non-zero amount of charge for a first portion of a first switching period and deliver no charge in a second portion of the first switching period until a subsequent cycle, thereby providing a first predetermined amount of charge per the first switching period, and

wherein the switched-capacitor regulator is configured to provide a second predetermined amount of charge per a second switching period; and

a first feedback system configured to:

compare the output voltage to a reference voltage to determine a first operating frequency for the switched-inductor regulator;



21

determine a second operating frequency for the switched-capacitor regulator based on the first predetermined amount of charge provided by the switched-inductor regulator per the first switching period and the second predetermined amount of charge per the second switching period;

cause the switched-inductor regulator to operate at the first operating frequency, and

cause the switched-capacitor regulator to operate at the second operating frequency; and

a second feedback system that is configured to determine a difference between a parasitic voltage drop and a target voltage drop of the switched-capacitor regulator and cause the switched-inductor regulator to adjust current provided to the switched-capacitor regulator based on the difference.

2. The voltage regulator system of claim 1, wherein the first feedback system is configured to cause the switched-inductor regulator to operate at the first operating frequency by providing a first periodic signal having the first operating frequency to the switched-inductor regulator.

3. The voltage regulator system of claim 2, wherein the first feedback system comprises a frequency divider that is configured to receive a second periodic signal generated by [the] *a* feedback control and to generate the first periodic signal having the first operating frequency, and wherein the first feedback system is configured to provide the second periodic signal to the switched-capacitor regulator.

4. The voltage regulator system of claim 1, wherein the switched-inductor regulator comprises a multi-phase switched-inductor regulator having a plurality of regulator cells, and wherein the first feedback system is configured to cause the switched-inductor regulator to operate at the first operating frequency by providing a plurality of periodic signals having the first operating frequency to the switched-inductor regulator, wherein the plurality of periodic signals are out-of-phase from one another.

5. The voltage regulator system of claim 1, wherein the first feedback system comprises a feedback control that is configured to generate a first periodic signal, based on the reference voltage and the output voltage, having the second operating frequency.

6. The voltage regulator system of claim 1, wherein the second feedback system is configured to cause the switched-inductor regulator to adjust the current provided to the switched-capacitor regulator by adjusting one or more of the first switching period, an active period, and a duty cycle *D* of the switched-inductor regulator.

7. The voltage regulator system of claim 1, wherein the first operating frequency is a fraction of the second operating frequency.

8. The voltage regulator system of claim 1, further comprising a plurality of bypass switches, wherein one of the bypass switches is configured to couple an input node of a first voltage regulator and an output node of a second voltage regulator in the hybrid regulator.

9. An electronic system comprising:

a load chip comprising a power domain, wherein the power domain comprises an input voltage terminal and a ground terminal; and

a voltage regulator system of claim 1, wherein the voltage regulator system is configured to provide the output voltage of the hybrid regulator to the input voltage terminal of the load chip.

22

10. A method of providing an output voltage based on an input voltage, the method comprising:

providing a hybrid regulator configured to convert the input voltage to the output voltage, wherein the hybrid regulator comprises a plurality of voltage regulators including at least a switched-inductor regulator and a switched-capacitor regulator, wherein the switched-inductor regulator is configured to provide a non-zero amount of charge for a first portion of a first switching period and deliver no charge in a second portion of the first switching period until a subsequent cycle of the switched-inductor regulator, and wherein the switched-capacitor regulator is configured to provide a second predetermined amount of charge per a second switching period; [and]

comparing, at a first feedback system, output voltage to a reference voltage to determine a first operating frequency for the switched-inductor regulator;

determining, by the first feedback system, a second operating frequency for the switched-capacitor regulator based on the first predetermined amount of charge provided by the switched-inductor regulator per the first switching period and the second predetermined amount of charge provided by the switched-capacitor regulator per a second switching period;

causing, by the first feedback system, the switched-inductor regulator to operate at the first operating frequency;

causing, by the first feedback system, the switched-capacitor regulator to operate at the second operating frequency; and

determine, by a second feedback system, a difference between a parasitic voltage drop and a target voltage drop of the switched-capacitor regulator and cause the switched-inductor regulator to adjust current provided to the switched-capacitor regulator based on the difference.

11. The method of claim 10, wherein causing the switched-inductor regulator to operate at the first operating frequency comprises providing a first periodic signal having the first operating frequency to the switched-inductor regulator.

12. The method of claim 11, further comprising:

receiving, at a frequency divider in the first feedback system, [the] *a* second periodic signal generated by [the] *a* feedback control;

generating, by the frequency divider, the first periodic signal having the first operating frequency; and providing the second periodic signal to the switched-capacitor regulator.

13. The method of claim 10, wherein the switched-inductor regulator comprises a multi-phase switched-inductor regulator having a plurality of regulator cells, and wherein causing the switched-inductor regulator to operate at the first operating frequency comprises providing a plurality of periodic signals having the first operating frequency to the switched-inductor regulator, wherein the plurality of periodic signals are out-of-phase from one another.

14. The method of claim 10, further comprising generating, at a feedback control in the first feedback system, a first periodic signal having the second operating frequency based on the reference voltage and the output voltage.

15. The method of claim 10, wherein causing the switched-inductor regulator to adjust the current provided to the switched-capacitor regulator is performed by adjusting one or more of: the first switching period, an active period, and/or a duty cycle *D* of the switched-inductor regulator.



16. The method of claim 10, wherein the hybrid regulator system comprises a plurality of bypass switches, wherein one of the bypass switches is configured to couple an input node and an output node of the one of the voltage regulators in the hybrid regulator.

17. A system for controlling a hybrid regulator that is configured to convert an input voltage to an output voltage, wherein the hybrid regulator comprises a plurality of voltage regulators including at least a switched-inductor regulator and a switched-capacitor regulator, the system comprising:

a first feedback system configured to:

compare the output voltage to a reference voltage to determine a first operating frequency for the switched-inductor regulator;

determine a second operating frequency for the switched-capacitor regulator based on (i) a first predetermined amount of charge provided by the switched-inductor regulator per a first switching period and (ii) a second predetermined amount of charge provided by the switched capacitor regulator per a second switching period, wherein the first predetermined amount of charge includes a non-zero amount of charge for a first portion of the first switch period and no charge in a second portion of the first switching period until a subsequent cycle;

cause the switched-inductor regulator to operate at the first operating frequency, and

cause the switched-capacitor regulator to operate at the second operating frequency; and

a second feedback system that is configured to:

determine a difference between a parasitic voltage drop and a target voltage drop of the switched-capacitor regulator and cause the switched-inductor regulator to adjust current provided to the switched-capacitor regulator based on the difference.

18. The system of claim 17, wherein the first feedback system is configured to cause the switched-inductor regulator to operate at the first operating frequency by providing a first periodic signal having the first operating frequency to the switched-inductor regulator.

19. The system of claim 18, wherein the first feedback system comprises a frequency divider that is configured to receive a second periodic signal generated by a feedback control and to generate the first periodic signal having the first operating frequency, and wherein the feedback system is configured to provide the second periodic signal to the switched-capacitor regulator.

20. The system of claim 17, wherein the systems further comprises the switched inductor regulator and wherein the switched-inductor regulator comprises a multi-phase switched-inductor regulator having a plurality of regulator cells, and wherein the first feedback system is configured to cause the switched-inductor regulator to operate at the first operating frequency by providing a plurality of periodic signals having the first operating frequency to the switched-inductor regulator, wherein the plurality of periodic signals are out-of-phase from one another.

21. The system of claim 17, wherein the first feedback system comprises a feedback control that is configured to generate a first periodic signal, based on the reference voltage and the output voltage, having the second operating frequency.

22. The system of claim 17, wherein the second feedback system is configured to cause the switched-inductor regulator to adjust the current provided to the switched-capacitor

regulator by adjusting one or more of the first switching period, an active period, and a duty cycle  $D$  of the switched-inductor regulator.

23. The system of claim 17, wherein the first operating frequency is a fraction of the second operating frequency.

24. The system of claim 17, wherein the system further comprises a plurality of bypass switches, wherein one of the bypass switches is configured to couple an input node of a first voltage regulator and an output node of a second voltage regulator in the hybrid regulator.

25. The system of claim 17, wherein the first feedback system is connected to the switched-inductor regulator and the switched-capacitor regulator.

26. The system of claim 17, wherein the second feedback system is connected to the switched-inductor regulator and the switched-capacitor regulator.

27. A method for controlling a hybrid regulator that is configured to convert an input voltage to an output voltage, wherein the hybrid regulator comprises a plurality of voltage regulators including at least a switched-inductor regulator and a switched-capacitor regulator, the method comprising:

comparing, at a first feedback system, the output voltage to a reference voltage to determine a first operating frequency for the switched-inductor regulator;

determining, by the first feedback system, a second operating frequency for the switched-capacitor regulator based on (i) a first predetermined amount of charge provided by the switched-inductor regulator per a first switching period and (ii) a second predetermined amount of charge provided by the switched capacitor regulator per a second switching period, wherein the first predetermined amount of charge includes a non-zero amount of charge for a first portion of the first switch period and no charge in a second portion of the first switching period until a subsequent cycle;

causing, by the first feedback system, the switched-inductor regulator to operate at the first operating frequency;

causing, by the first feedback system, the switched-capacitor regulator to operate at the second operating frequency; and

determine, by a second feedback system, a difference between a parasitic voltage drop and a target voltage drop of the switched-capacitor regulator and cause the switched-inductor regulator to adjust current provided to the switched-capacitor regulator based on the difference.

28. The method of claim 27, wherein causing the switched-inductor regulator to operate at the first operating frequency comprises providing a first periodic signal having the first operating frequency to the switched-inductor regulator.

29. The method of claim 28, further comprising: receiving, at a frequency divider in the first feedback system, a second periodic signal generated by a feedback control;

generating, by the frequency divider, the first periodic signal having the first operating frequency; and providing the second periodic signal to the switched-capacitor regulator.

30. The method of claim 27, wherein causing the switched-inductor regulator to adjust the current provided to the switched-capacitor regulator is performed by adjusting one or more of: the first switching period, an active period, and/or a duty cycle  $D$  of the switched-inductor regulator.



25

31. The method of claim 27, wherein the hybrid regulator system comprises a plurality of bypass switches, wherein one of the bypass switches is configured to couple an input node and an output node of the one of the voltage regulators in the hybrid regulator.

32. The method of claim 27, wherein the first feedback system is connected to the switched-inductor regulator and the switched-capacitor regulator.

33. The method of claim 27, wherein the second feedback system is connected to the switched-inductor regulator and the switched-capacitor regulator.

34. The method of claim 27, wherein the switched-inductor regulator comprises a multi-phase switched-inductor regulator having a plurality of regulator cells, and wherein causing the switched-inductor regulator to operate at the first operating frequency comprises providing a plurality of periodic signals having the first operating frequency to the switched-inductor regulator, wherein the plurality of periodic signals are out-of-phase from one another.

35. The method of claim 27, further comprising generating, at a feedback control in the first feedback system, a first periodic signal having the second operating frequency based on the reference voltage and the output voltage.

36. A voltage regulator system comprising:

a plurality of voltage converters arranged in series between an input voltage and an output voltage, wherein the plurality of voltage converters includes a switched-capacitor regulator and a switched-inductor regulator;

at least one bypass switch arranged to selectively couple an input node of at least one of the plurality of voltage converters and an output node of the at least one of the plurality of voltage converters; and

26

a feedback system that is configured to determine a difference between a parasitic voltage drop and a target voltage drop of the switched-capacitor regulator and cause the switched-inductor regulator to adjust current provided to the switched-capacitor regulator based on the difference.

37. The voltage regulator system of 36, wherein the at least one bypass switch is controlled based on at least one of the following: the input voltage, the output voltage, a conversion ratio of a switched capacitor regulator in the plurality of voltage converters, and a parasitic switched capacitor voltage drop of the switched capacitor regulator.

38. The voltage regulator system of 36, wherein a separate bypass switch is provided for each of the plurality of voltage converters.

39. The voltage regulator system of 36, wherein the at least one bypass switch includes two bypass switches that collectively couple an input node of one converter stage and an output node of another converter stage.

40. The voltage regulator system of 36, wherein at least one of the plurality of voltage converters comprises a reconfigurable converter that has multiple inputs and multiple outputs, and one or more switch matrices that can choose an input from the multiple inputs and an output from the multiple outputs.

41. The voltage regulator system of 40, wherein the reconfigurable converter comprises a switched capacitor converter that can reconfigure a step-down ratio of the switched capacitor converters across a plurality of values including at least two of 2:1, 3:1, 4:1, and 5:1.

\* \* \* \* \*

UNITED STATES PATENT AND TRADEMARK OFFICE  
**CERTIFICATE OF CORRECTION**

PATENT NO. : RE49,763 E  
APPLICATION NO. : 17/407103  
DATED : December 19, 2023  
INVENTOR(S) : Hanh-Phuc Le et al.

Page 1 of 1

It is certified that error appears in the above-identified patent and that said Letters Patent is hereby corrected as shown below:

In the Claims

Column 23, Claim 16, Line 2:

“comprises a plurality of bypass switche”

Should be:

--comprises a plurality of bypass switches--

Column 23, Claim 17, Line 24:

“predetemin amount of charge”

Should be:

--predetermined amount of charge--

Column 24, Claim 27, Line 33:

“predetemin amount of charge”

Should be:

--predetermined amount of charge--

Signed and Sealed this  
Third Day of September, 2024  
*Katherine Kelly Vidal*

Katherine Kelly Vidal  
*Director of the United States Patent and Trademark Office*