



US00RE49616E

(19) **United States**
(12) **Reissued Patent**
Belanger et al.

(10) **Patent Number: US RE49,616 E**
(45) **Date of Reissued Patent: *Aug. 22, 2023**

(54) **ADJUSTABLE HOCKEY HELMET**

(71) Applicant: **BAUER HOCKEY, LLC**, Exeter, NH (US)

(72) Inventors: **Guillaume Belanger**, Terrebonne (CA);
Jean-Francois Beland, Sainte-Therese (CA)

(73) Assignee: **BAUER HOCKEY, LLC**, Exeter, NH (US)

(*) Notice: This patent is subject to a terminal disclaimer.

(21) Appl. No.: **17/466,130**

(22) Filed: **Sep. 3, 2021**

Related U.S. Patent Documents

Reissue of:

(64) Patent No.: **8,832,870**
Issued: **Sep. 16, 2014**
Appl. No.: **13/654,260**
Filed: **Oct. 17, 2012**

U.S. Applications:

(63) Continuation of application No. 16/867,511, filed on May 5, 2020, now Pat. No. Re. 48,769, which is a continuation of application No. 15/904,016, filed on Feb. 23, 2018, now Pat. No. Re. 48,048, which is a continuation of application No. 15/268,127, filed on Sep. 16, 2016, now Pat. No. Re. 47,747, which is an
(Continued)

(51) **Int. Cl.**
A42B 3/32 (2006.01)

(52) **U.S. Cl.**
CPC **A42B 3/324** (2013.01)

(58) **Field of Classification Search**

CPC **A42B 3/324**
See application file for complete search history.

(56) **References Cited**

U.S. PATENT DOCUMENTS

2,926,406 A 3/1960 Edwards et al.
3,087,166 A 4/1963 Howard
(Continued)

FOREIGN PATENT DOCUMENTS

CA 1154552 10/1983
CA 1183302 A 3/1985
(Continued)

OTHER PUBLICATIONS

Bauer Hockey, Voluntary Amendment with Submission of References, filed in Canadian Patent Application No. 2,916,360, Sep. 23, 2016, 17 pgs.

(Continued)

Primary Examiner — William C Doerrler

(74) *Attorney, Agent, or Firm* — Perkins Coie LLP

(57) **ABSTRACT**

An adjustable hockey helmet includes a front shell that is longitudinally movable relative to a rear shell to adjust the length of the helmet. One or more substantially rigid straps or similar elements are attached to the front shell and extend to the interior of the rear shell. A cam mechanism or similar device is included on the rear shell for securing the straps directly or indirectly against the interior of the rear shell to prevent longitudinal movement of the front shell relative to the rear shell once the helmet is adjusted to a desired length. Alternatively, the one or more straps may be attached to the rear shell and the cam mechanism may be included on the front shell.

33 Claims, 25 Drawing Sheets

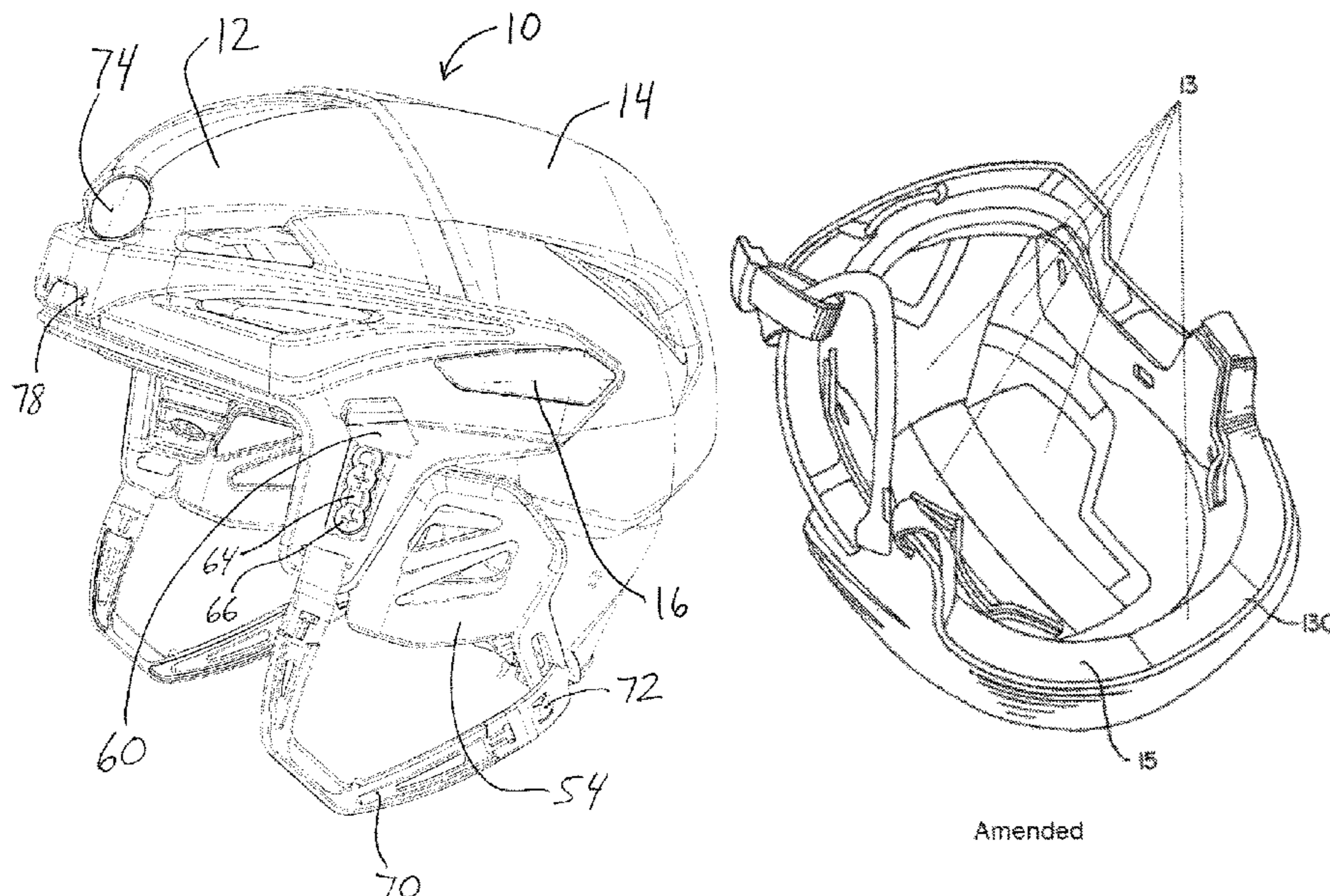

Related U.S. Application Data

application for the reissue of Pat. No. 8,832,870, which is a continuation of application No. 12/191,000, filed on Aug. 13, 2008, now Pat. No. 8,296,868.

(60) Provisional application No. 60/956,621, filed on Aug. 17, 2007.

(56) **References Cited**

U.S. PATENT DOCUMENTS

3,107,356 A 10/1963 Pestronk
 3,214,809 A 11/1965 Edwards
 3,720,955 A * 3/1973 Rawlings A42B 3/127
 2/415
 3,845,505 A 11/1974 Davison
 3,897,597 A * 8/1975 Kasper 2/9
 4,404,690 A 9/1983 Farquharson
 4,477,929 A * 10/1984 Mattsson 2/425
 4,539,715 A 9/1985 Clement
 4,685,315 A 8/1987 Comolli et al.
 4,827,537 A 5/1989 Villa
 4,843,642 A 7/1989 Brower
 4,856,950 A 8/1989 Bushnell
 4,903,349 A 2/1990 Arai
 4,942,628 A * 7/1990 Freund 2/416
 5,143,500 A 9/1992 Schuring
 5,249,347 A * 10/1993 Martinitz 29/460
 5,315,718 A * 5/1994 Barson et al. 2/418
 5,331,684 A 7/1994 Baril
 5,333,328 A 8/1994 Roberts
 5,351,341 A 10/1994 Broersma
 5,367,402 A 11/1994 Holmes
 5,412,814 A * 5/1995 Pernicka et al. 2/424
 5,469,583 A 11/1995 Akeley et al.
 5,483,699 A * 1/1996 Pernicka et al. 2/9
 RE35,193 E 4/1996 Shifrin
 5,511,250 A 4/1996 Field et al.
 5,540,528 A 7/1996 Schmidt
 5,555,567 A 9/1996 Corpus
 5,555,569 A 9/1996 Lane
 5,571,217 A * 11/1996 Del Bon et al. 2/9
 5,603,117 A 2/1997 Hudner
 5,638,551 A 6/1997 Lallemand et al.
 5,659,900 A 8/1997 Arney et al.
 5,680,656 A 10/1997 Gath
 5,752,276 A 5/1998 Baudou
 D400,311 S * 10/1998 Chartrand D29/122
 D401,018 S 11/1998 Chartrand
 5,832,569 A 11/1998 Berg et al.
 5,845,341 A * 12/1998 Barthold et al. 2/424
 5,857,215 A 1/1999 Ferguson
 5,887,288 A 3/1999 Arney et al.
 5,950,245 A 9/1999 Binduga
 5,953,761 A 9/1999 Jurga et al.
 5,956,776 A 9/1999 Chartrand
 6,032,297 A 3/2000 Barthold et al.
 6,047,409 A 4/2000 Simpson
 6,101,636 A * 8/2000 Williams 2/410
 6,108,824 A 8/2000 Fournier et al.
 6,125,477 A * 10/2000 Crippa et al. 2/422
 6,154,889 A 12/2000 Moore, III
 6,189,156 B1 2/2001 Loiers
 6,202,223 B1 3/2001 Chartrand
 6,256,798 B1 7/2001 Egolf et al.
 6,260,197 B1 7/2001 Hoogewind
 6,272,692 B1 * 8/2001 Abraham 2/411
 6,292,952 B1 9/2001 Watters
 6,298,497 B1 10/2001 Chartrand
 6,314,588 B1 11/2001 Fang
 6,324,700 B1 12/2001 McDougall
 6,338,165 B1 * 1/2002 Biondich 2/424
 6,385,780 B1 5/2002 Racine
 6,389,607 B1 * 5/2002 Wood 2/425
 6,401,261 B1 6/2002 Arney et al.
 6,425,142 B2 7/2002 Sasaki et al.

6,449,776 B1 9/2002 Musal
 D463,885 S 10/2002 Burns
 6,457,179 B1 10/2002 Prendergast
 6,472,776 B1 10/2002 Soto
 6,499,149 B2 12/2002 Ashline
 6,606,114 B1 8/2003 Gordon
 6,647,556 B2 11/2003 Grepper
 6,708,376 B1 3/2004 Landry
 6,715,150 B1 4/2004 Potin
 6,754,911 B1 6/2004 Howell
 6,772,447 B2 * 8/2004 Morrow et al. 2/424
 6,862,747 B2 3/2005 Oleson
 6,862,748 B2 3/2005 Prendergast
 6,865,752 B2 * 3/2005 Udelhofen et al. 2/425
 6,880,176 B2 * 4/2005 Timms A42B 3/28
 2/184.5
 6,883,183 B2 * 4/2005 Morrow et al. 2/425
 6,886,183 B2 * 5/2005 DeHaan et al. 2/6.7
 6,892,393 B1 5/2005 Provost
 6,904,618 B2 6/2005 Musal
 6,934,972 B2 8/2005 Desjardins
 6,952,839 B2 * 10/2005 Long 2/414
 6,961,963 B2 * 11/2005 Rosie 2/171.3
 6,966,075 B2 * 11/2005 Racine 2/425
 6,968,575 B2 * 11/2005 Durocher 2/425
 6,981,284 B2 * 1/2006 Durocher 2/425
 6,983,488 B2 1/2006 Foote
 7,000,262 B2 2/2006 Bielefeld
 7,043,772 B2 5/2006 Bielefeld
 7,110,743 B2 9/2006 Depew et al.
 7,156,536 B1 1/2007 McCorkle
 7,174,575 B1 2/2007 Scherer
 7,178,175 B2 2/2007 Rogers
 7,192,151 B2 3/2007 Cluppenn
 D540,491 S * 4/2007 Tiegs D29/112
 7,222,374 B2 5/2007 Musal et al.
 7,246,383 B2 7/2007 Musal
 7,246,385 B2 7/2007 Dennis
 7,634,820 B2 12/2009 Rogers
 7,716,754 B1 5/2010 Ross
 D618,857 S 6/2010 Durocher
 7,765,608 B2 * 8/2010 Durocher et al. 2/9
 7,797,763 B2 9/2010 Grau
 7,797,764 B2 9/2010 Norris
 7,854,024 B2 12/2010 Fang
 7,870,618 B2 1/2011 Pilon
 7,908,667 B2 3/2011 Rogers
 7,908,678 B2 3/2011 Brine, III
 7,954,178 B2 6/2011 Durocher
 7,958,572 B2 6/2011 Loury
 7,975,320 B2 7/2011 Muskovitz
 8,037,548 B2 * 10/2011 Alexander et al. 2/418
 8,095,995 B2 1/2012 Alexander
 8,146,177 B2 4/2012 Mangone
 8,191,179 B2 6/2012 Durocher
 8,418,270 B2 4/2013 Desjardins
 8,661,571 B1 3/2014 Teetzel
 8,739,318 B2 6/2014 Durocher
 8,813,269 B2 8/2014 Bologna
 RE47,747 E * 12/2019 Belanger A42B 3/324
 RE48,048 E * 6/2020 Belanger A42B 3/324
 RE48,769 E * 10/2021 Belanger A42B 3/324
 2001/0034895 A1 * 11/2001 Ikeda 2/414
 2002/0035748 A1 * 3/2002 Racine 2/414
 2002/0104153 A1 8/2002 Benedict
 2003/0070201 A1 * 4/2003 McClelland 2/9
 2003/0106138 A1 * 6/2003 Guay 2/418
 2003/0135914 A1 * 7/2003 Racine et al. 2/413
 2003/0221245 A1 * 12/2003 Lee et al. 2/412
 2004/0040073 A1 * 3/2004 Morrow et al. 2/424
 2004/0117897 A1 * 6/2004 Udelhofen et al. 2/421
 2004/0172739 A1 * 9/2004 Racine 2/417
 2005/0015857 A1 * 1/2005 Desjardins et al. 2/417
 2005/0034222 A1 * 2/2005 Durocher 2/425
 2005/0034223 A1 * 2/2005 Durocher 2/425
 2005/0115857 A1 6/2005 Homann
 2005/0125882 A1 * 6/2005 Long 2/414
 2005/0125961 A1 6/2005 Pontaoe
 2005/0217006 A1 10/2005 Sutter

(56)

References Cited

OTHER PUBLICATIONS

U.S. PATENT DOCUMENTS

2005/0246868	A1	11/2005	Garofalo	
2005/0262618	A1	12/2005	Musal	
2005/0262619	A1*	12/2005	Musal et al.	2/421
2006/0010583	A1	1/2006	Dennis	
2006/0031978	A1	2/2006	Pierce	
2006/0150304	A1	7/2006	Bentz	
2007/0044193	A1	3/2007	Durocher et al.	
2007/0079429	A1	4/2007	Pilon et al.	
2007/0157370	A1	7/2007	Joubert Des Ouches	
2007/0169251	A1	7/2007	Rogers et al.	
2007/0199136	A1	8/2007	Brine et al.	
2007/0266281	A1*	11/2007	Kwark	H01L 23/3675 714/724
2007/0266481	A1	11/2007	Alexander et al.	
2007/0266482	A1	11/2007	Alexander et al.	
2008/0092279	A1	4/2008	Chiang	
2008/0109946	A1	5/2008	Jourde	
2008/0189835	A1	8/2008	Mangone	
2008/0276354	A1	11/2008	Stokes et al.	
2008/0289085	A1	11/2008	Bryant	
2009/0031482	A1	2/2009	Stokes	

FOREIGN PATENT DOCUMENTS

CA	1183302	A1	3/1985
CA	1217601		2/1987
CA	2048028	C	12/1994
CA	2191683	A1	5/1998
CA	2191683	C	5/1998
CA	2191693	A1	5/1998
CA	2191693	C	5/1998
CA	2273621		2/2000
CA	2321399	A1	3/2002
CA	2357690		3/2003
CA	2437545		2/2005
CA	2437626		2/2005
CA	2321399	C	1/2006
CA	2573639	A1	1/2006
CA	2573640	A1	1/2006
CA	2576086	A1	2/2006
CA	2561540		3/2007
CA	2567010	C	1/2008
CA	2230616	C	4/2008
CN	101516221		8/2009
DE	4226551		2/1994
DE	4322339	C2	8/1996
DE	10037461		2/2002
DE	10039461	A1	2/2002
EP	942665	B1	9/1999
EP	1204336	B1	5/2002
EP	1210882	B1	6/2002
EP	1484990	B1	10/2007
EP	1635664	B1	8/2010
EP	2550885	B1	1/2013
JP	3122726	U	6/2006
WO	2004000054	A2	12/2003
WO	2005000056	A2	1/2005
WO	2006099928	A1	9/2006
WO	2007025500	A1	3/2007

Bauer Hockey, Request for Examination with Submission of References, filed in Canadian Patent Application No. 2,963,353, Apr. 5, 2017, 20 pgs.

Bauer Hockey, Request for Reinstatement with Amendment after Allowance and Voluntary Submission of Information, filed in Canadian Patent Application No. 2,963,353, Nov. 28, 2017, 20 pgs.

Canadian Intellectual Property Office, Office Action in Canadian Patent Application No. 2,638,703, dated Oct. 23, 2014, 4 pgs.

Canadian Intellectual Property Office, Office Action with Examination Search Report in Canadian Patent Application No. 2,916,360, dated Oct. 18, 2016, 4 pgs.

Canadian Intellectual Property Office, Notice of Allowance in Canadian Patent Application No. 2,989,211, dated Sep. 6, 2018, 1 pg.

Canadian Intellectual Property Office, Office Action with Examination Search Report in Canadian Patent Application No. 3,016,111, dated Sep. 25, 2018, 5 pgs.

Canadian Intellectual Property Office, Notice of Allowance in Canadian Patent Application No. 3,016,097, dated Sep. 26, 2018, 1 pg.

Sport Maska Inc. d.b.a. Reebok-CCM Hockey, *Bauer Hockey Ltd. v. Sport Maska Inc. d.b.a. Reebok-CCM Hockey*, Federal Court of Canada, Court File No. T-123-15, Thrice Amended Statement of Defence and Counterclaim, Feb. 19, 2018, 43 pages.

Sport Maska Inc. d.b.a. CCM Hockey, *Bauer Hockey Ltd. v. Sport Maska Inc. d.b.a. CCM Hockey*, Federal Court of Canada, Court File No. T-123-15, Fourth Amended Statement of Defence and Counterclaim, citing items 78-84 and 88 below, May 25, 2018.

Sport Maska Inc. d.b.a. CCM Hockey, *Bauer Hockey Ltd. v. Sport Maska Inc. d.b.a. Reebok-CCM Hockey*, Federal Court of Canada, Court File No. T-123-15, Fifth Amended Statement of Defense and Counterclaim, May 9, 2019, 80 pages.

Bauer 8000, 5000 Helmet (see, for example, 2005 Bauer Catalogue).

CCM 1092/892 Helmets (see, for example, CCM 2006 Player Catalogue).

Cooper XLT Super Pro Helmet (see, for example, Cooper 1987 Catalogue, 84 pages).

Giro Omen snowboard helmet (see, for example, Giro Omen Helmet 101 brochure, 7 pages), exact publication date unknown.

Halstead, P.D., et al. "Hockey Headgear and the Adequacy of Current Designs and Standards", *Safety in Ice Hockey*, ASTM STP 1341, A.B. Ashare, Editor, American Society for Testing and Materials, 1998. 8 pages.

Mission Intake Helmet (see, for example, 2007 Hockey Catalogue).

Nike Bauer 8500/5500 Helmet (see, for example, 2006 Nike Bauer Catalogue).

Nike Quest Helmet (see, for example, 2004 Nike Player Catalogue).

RBK 8K and 6K Helmets (see, for example, 2006 RBK Hockey Catalogue).

RBK 8K Helmet (see, for example, 2007 Roller Hockey Collection Catalogue).

Reebok, RBK 8K Helmet, 2005.

U.S. Appl. No. 75/143,500, filed Sep. 1, 1992, Schuring.

* cited by examiner

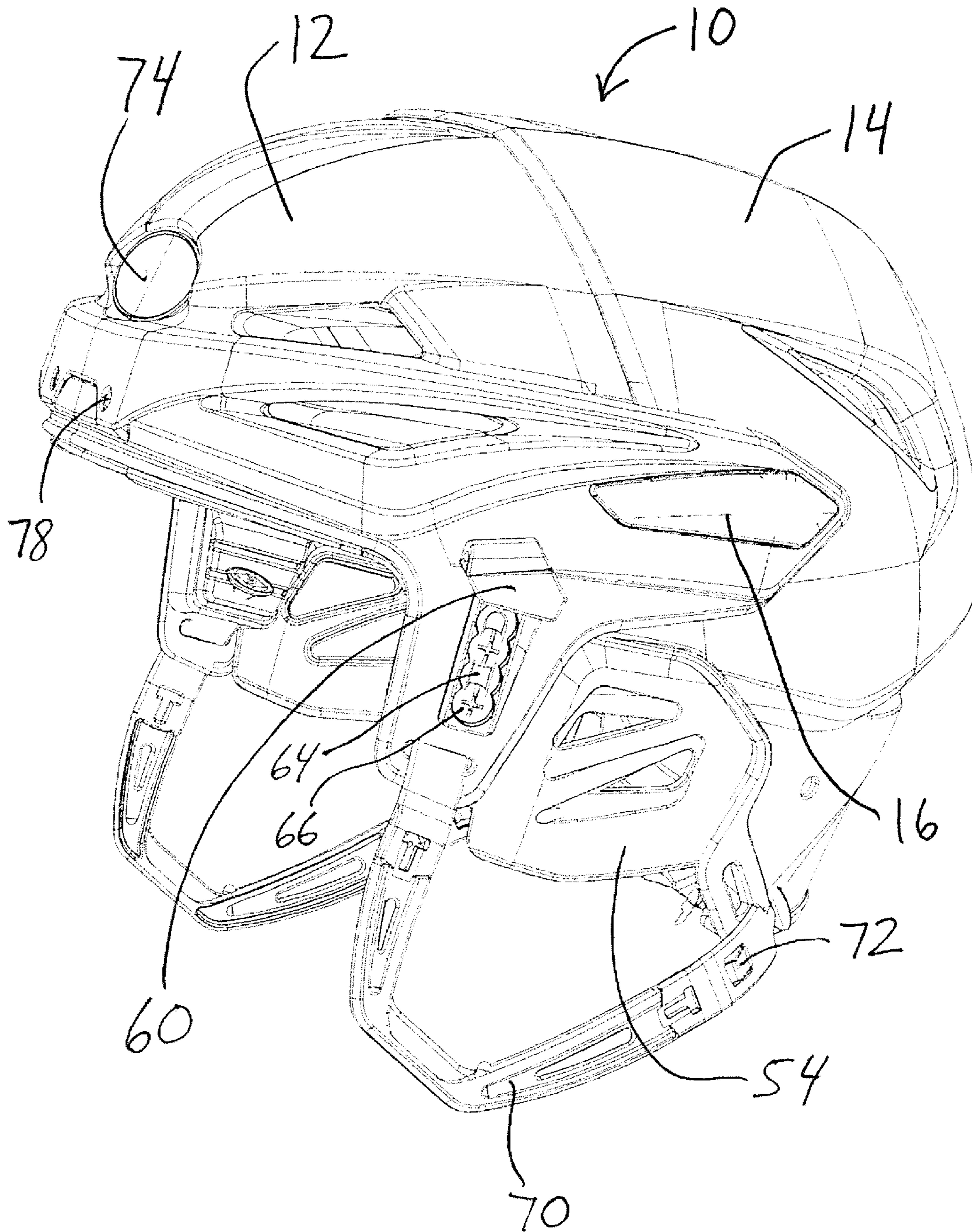

Fig. 1

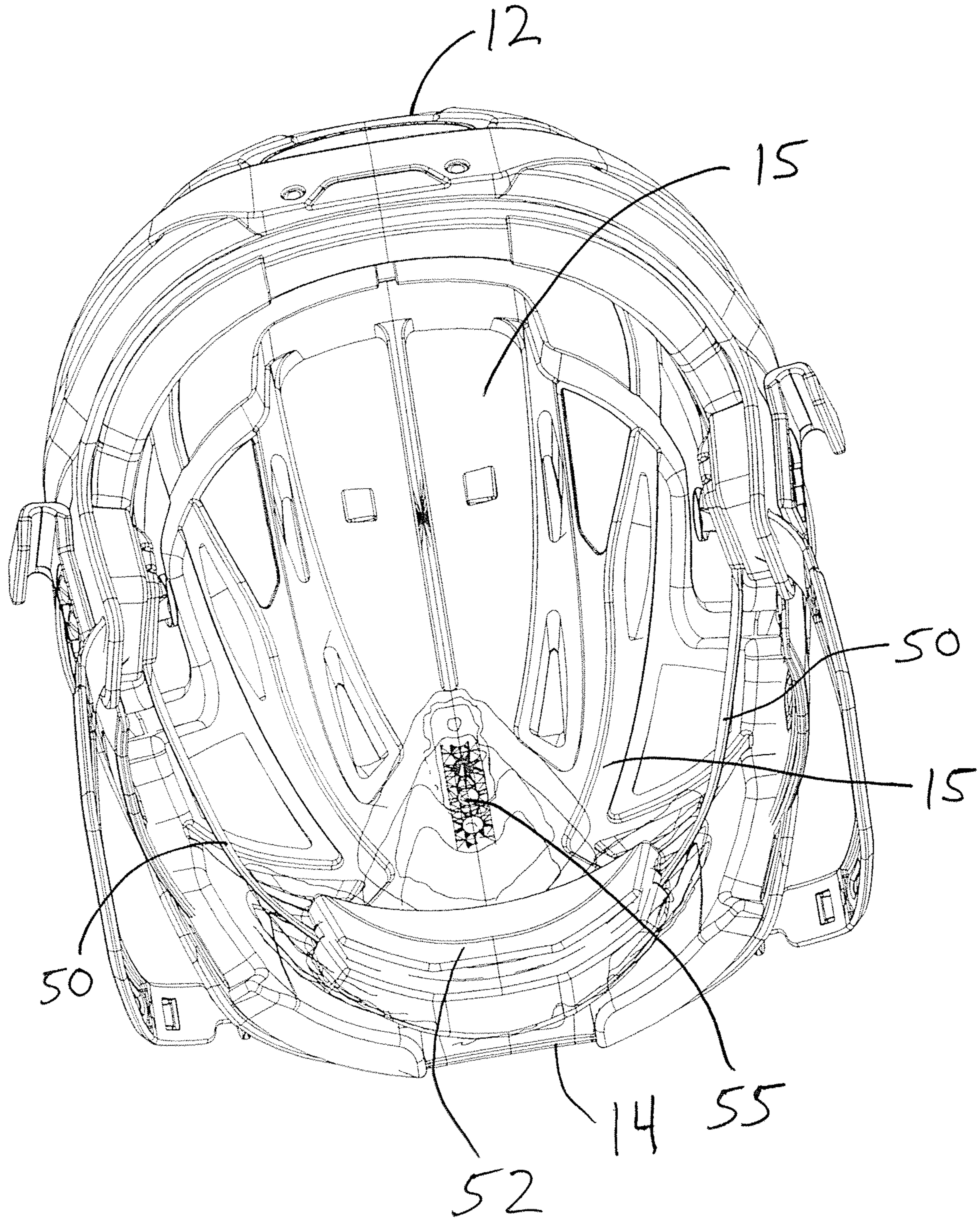

Fig. 2

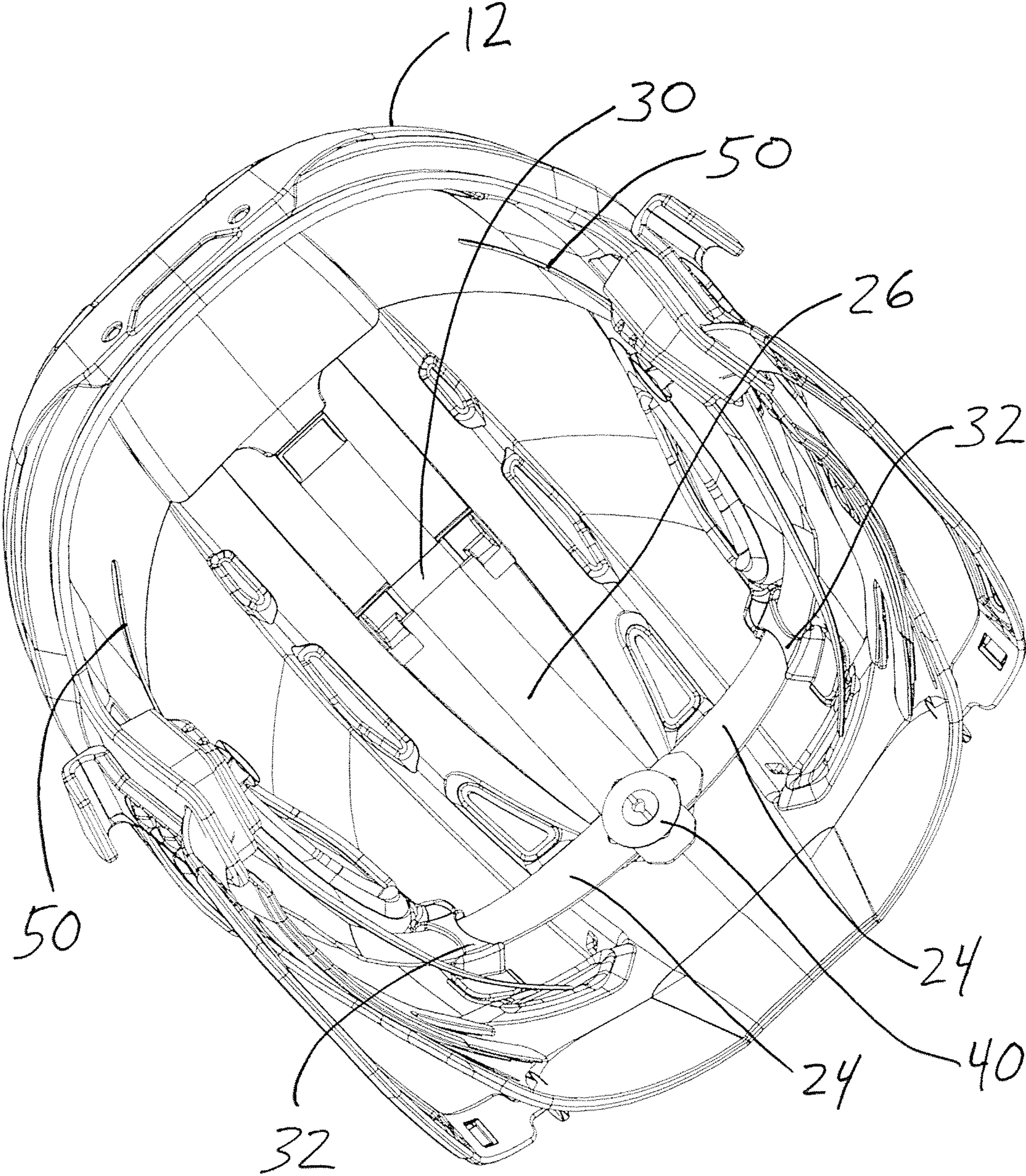

Fig. 3



Fig. 4A

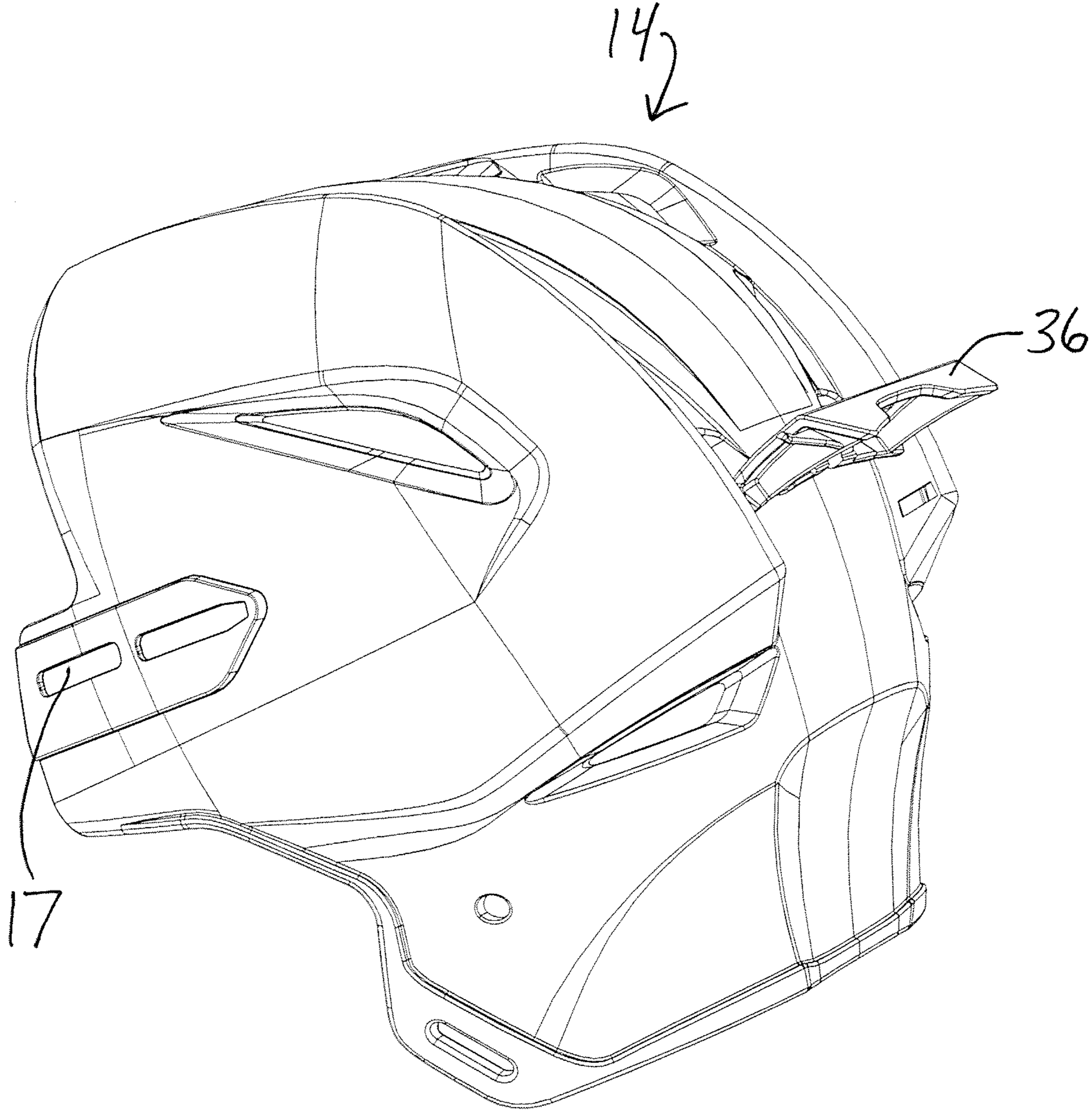

Fig. 4B

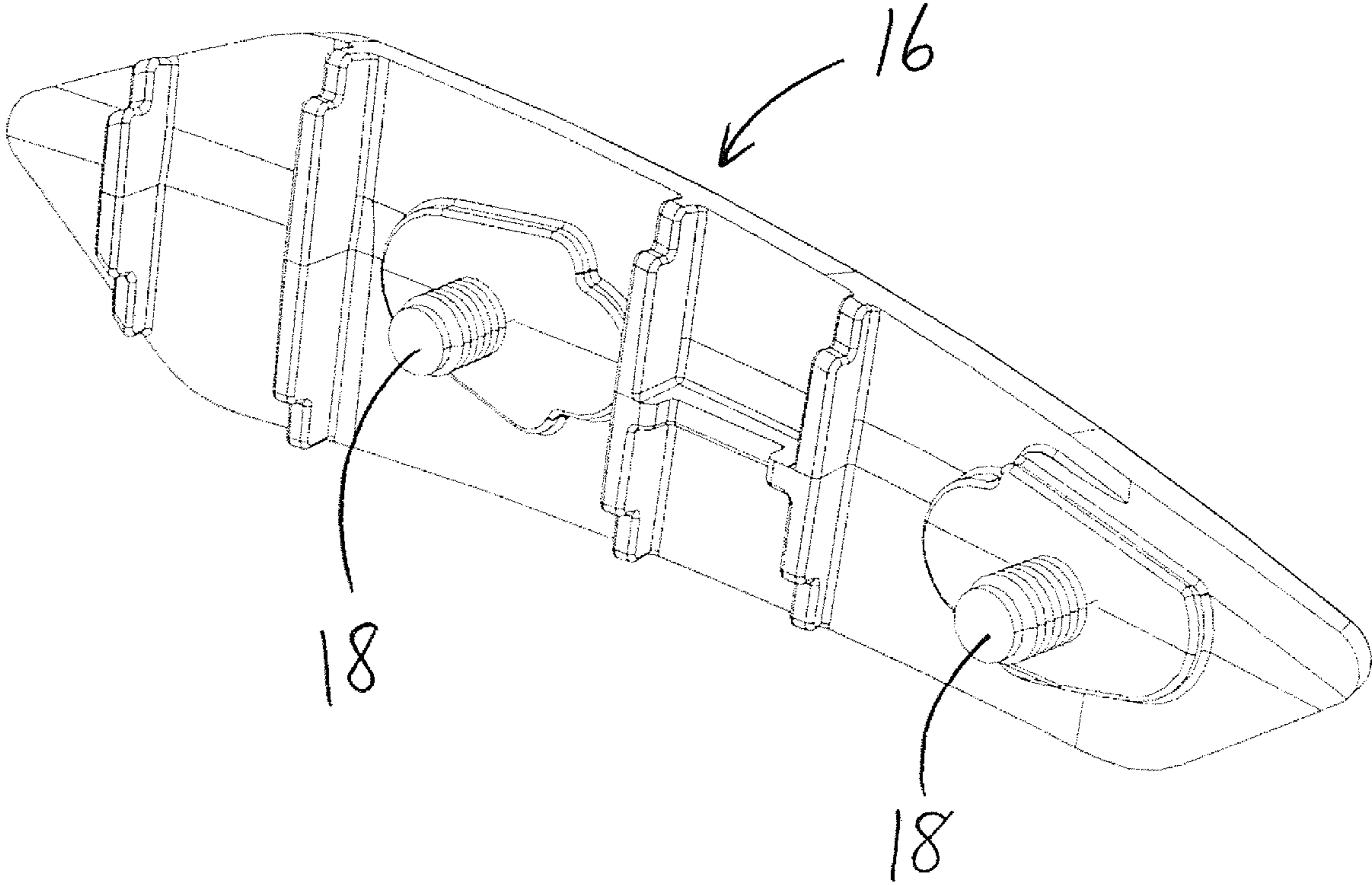

Fig. 5

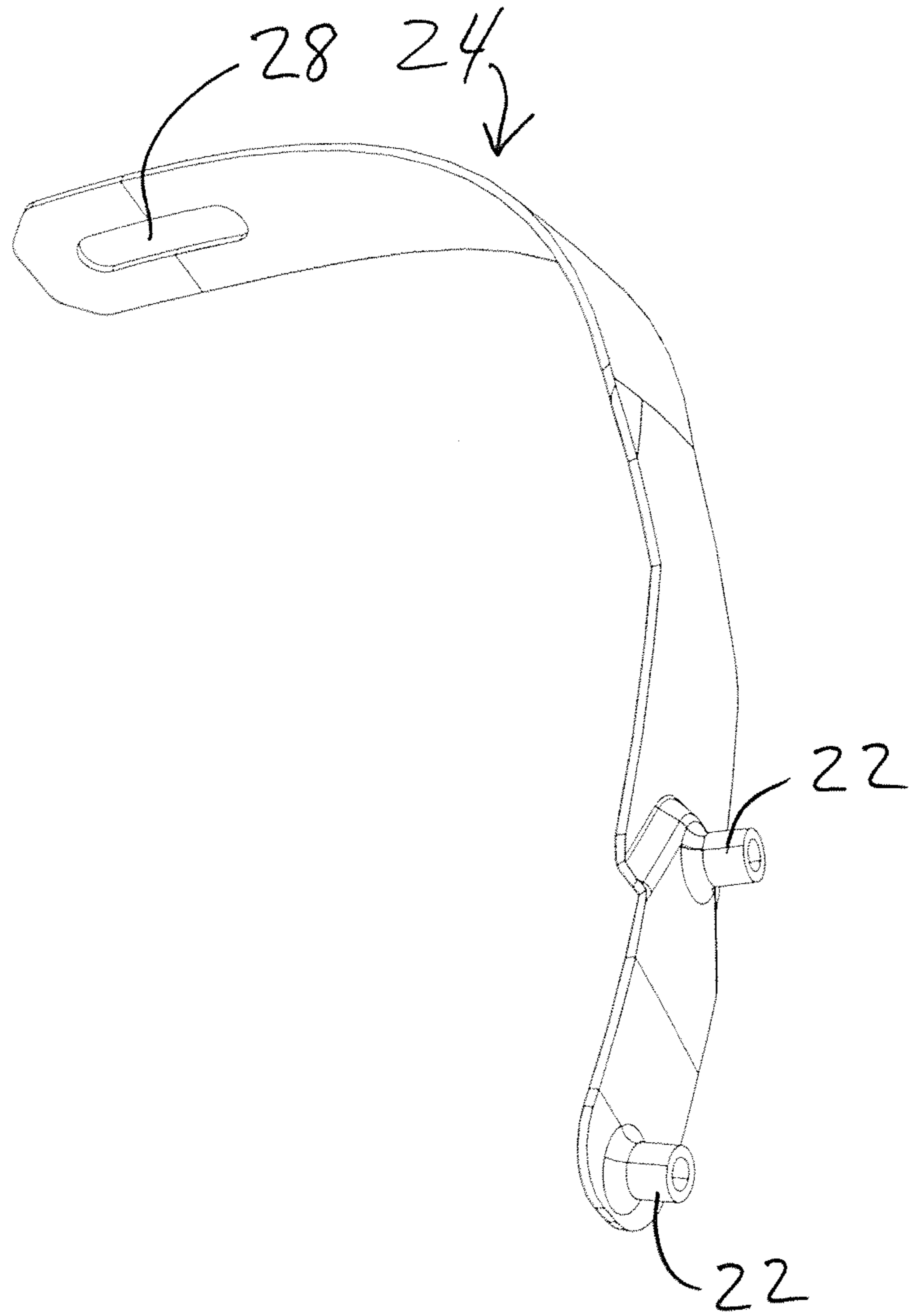

Fig. 6

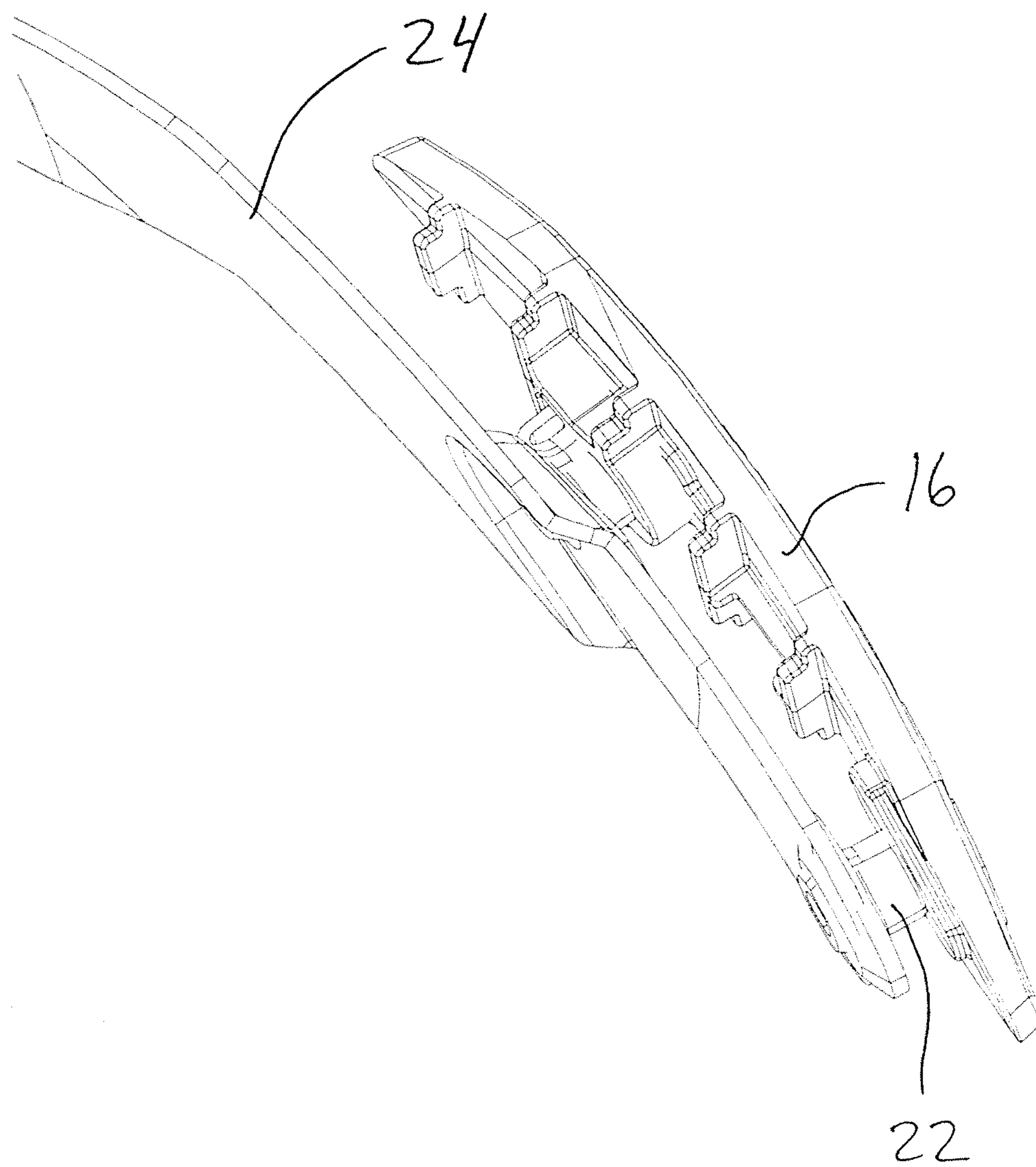

Fig. 7

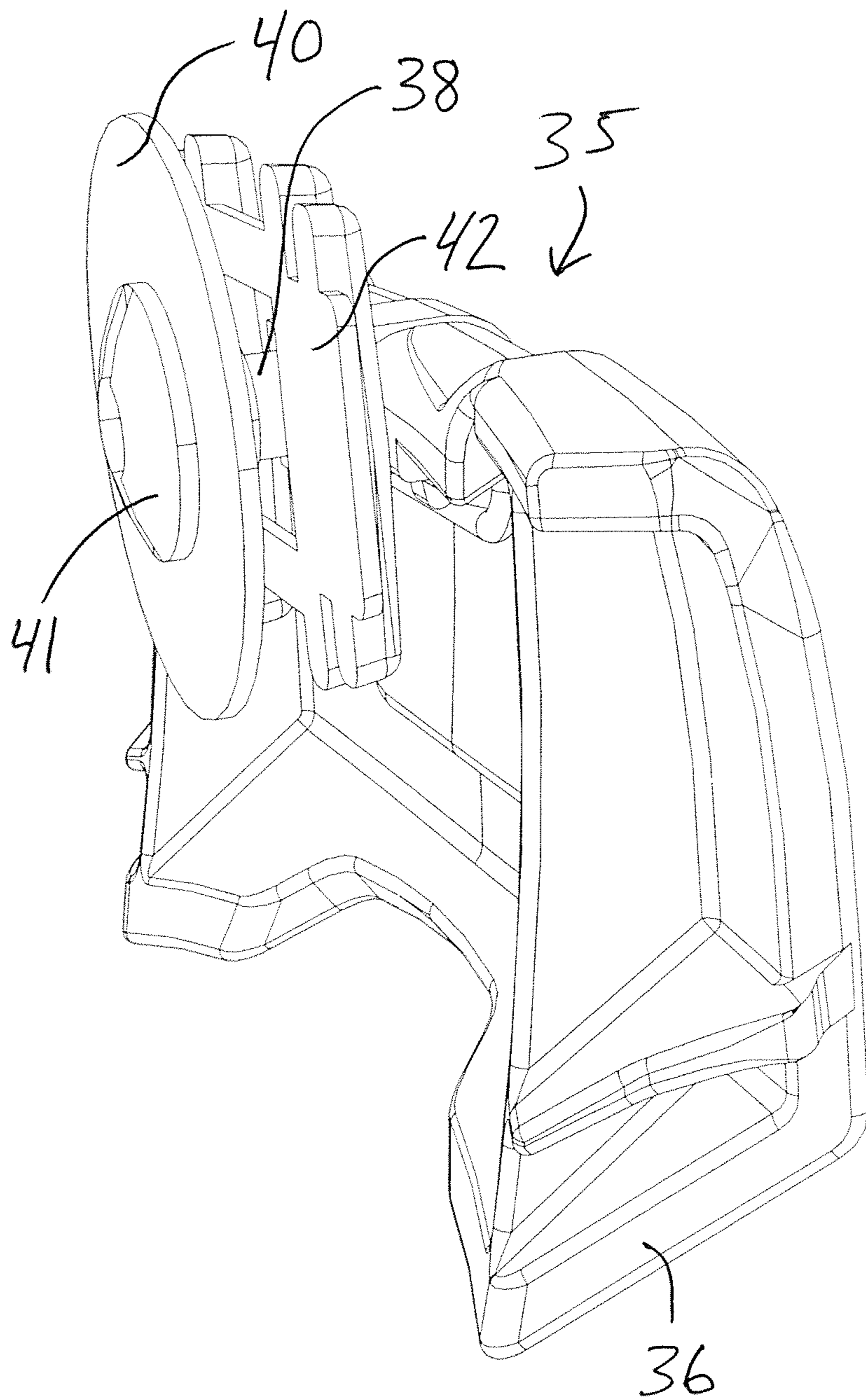

Fig. 8

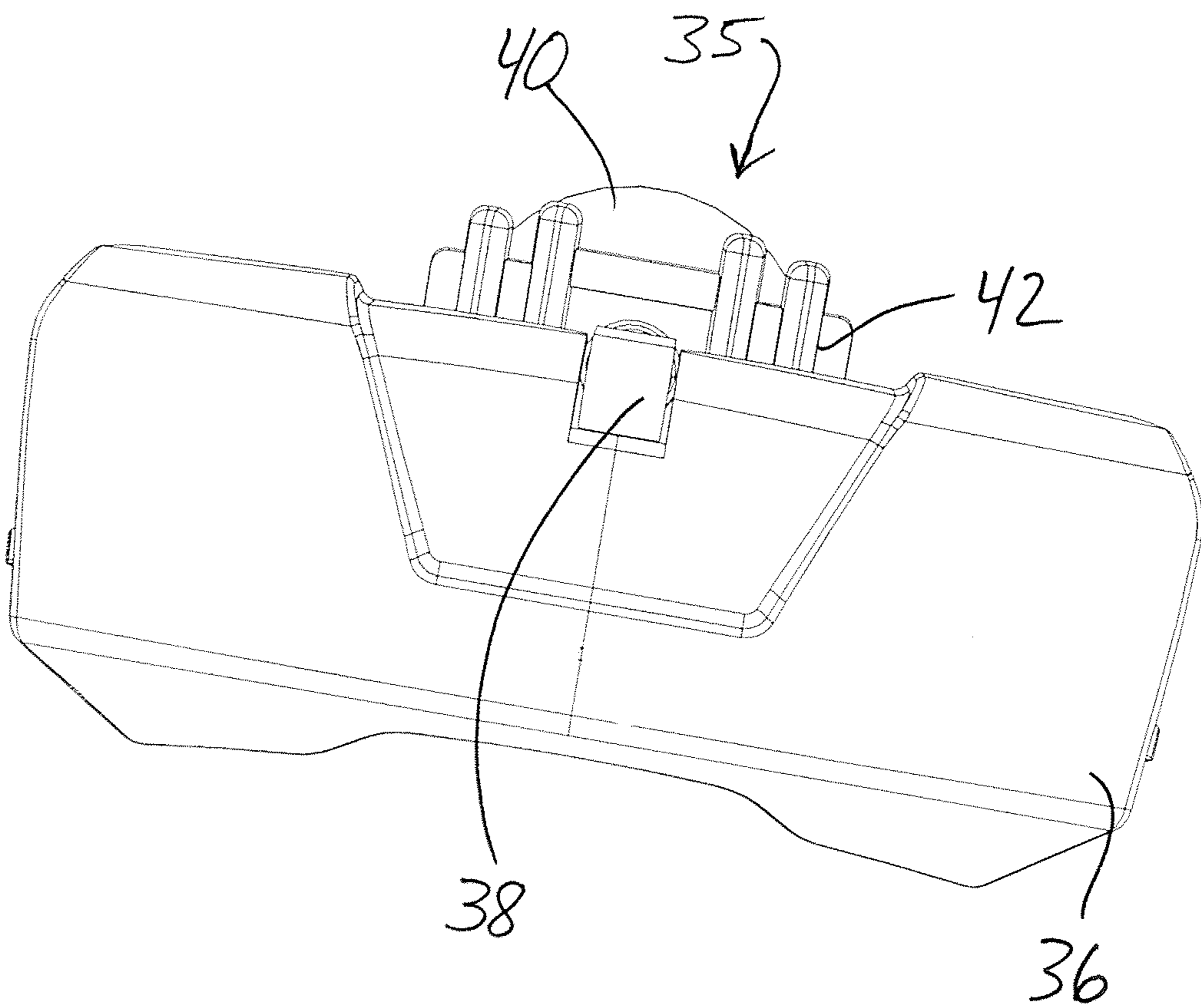

Fig. 9

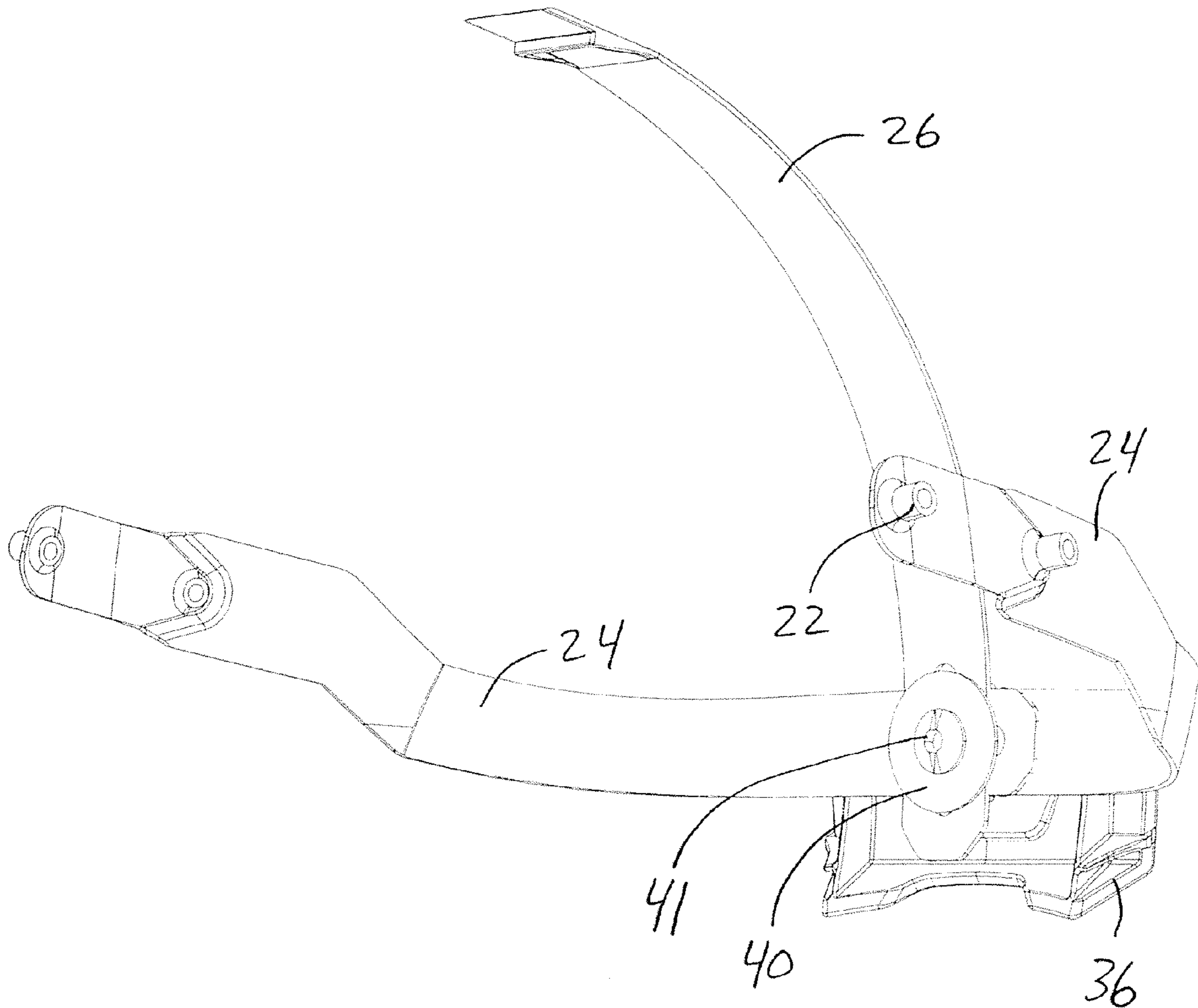

Fig. 10

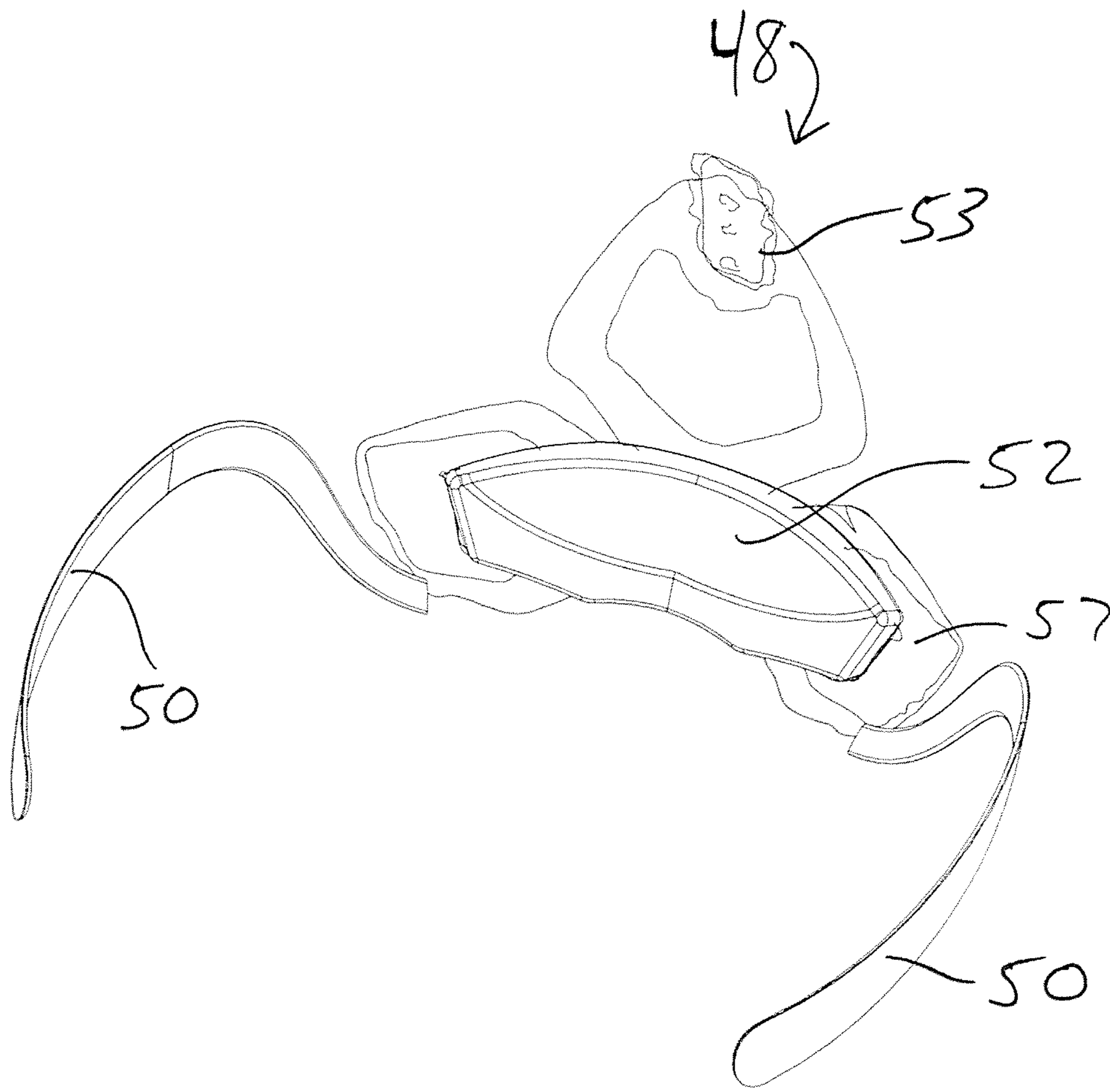

Fig. 11

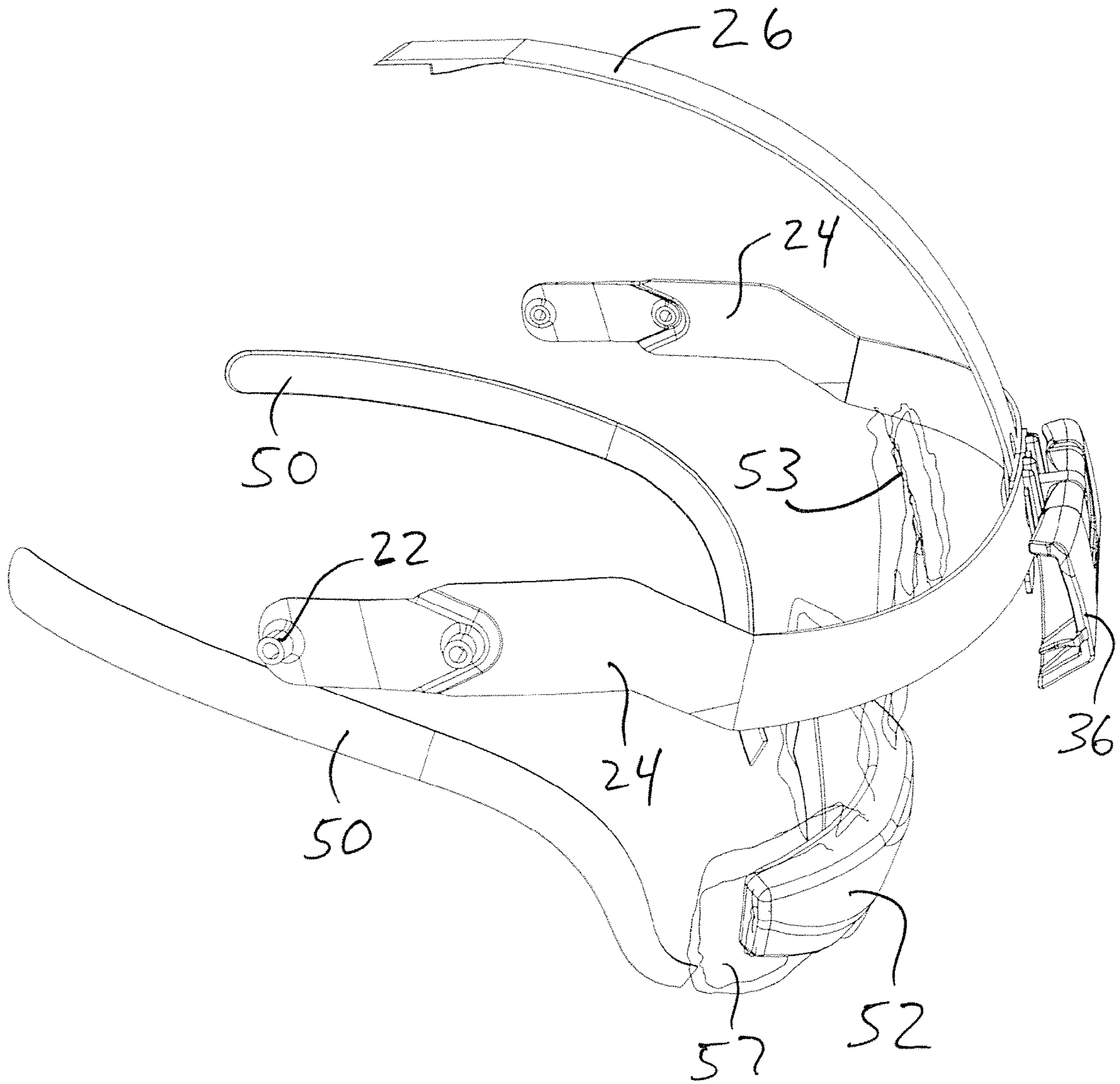

Fig. 12

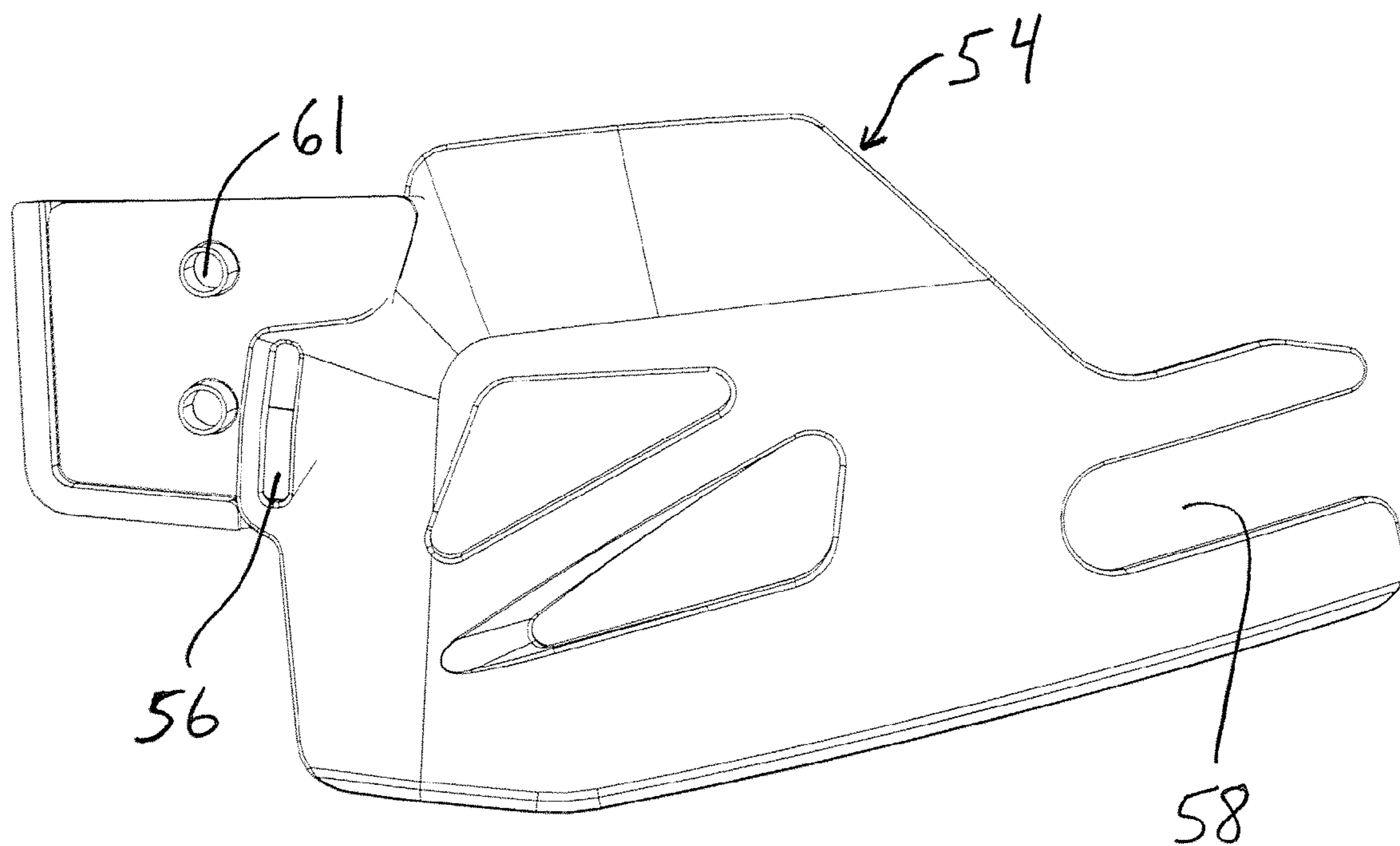

Fig. 13

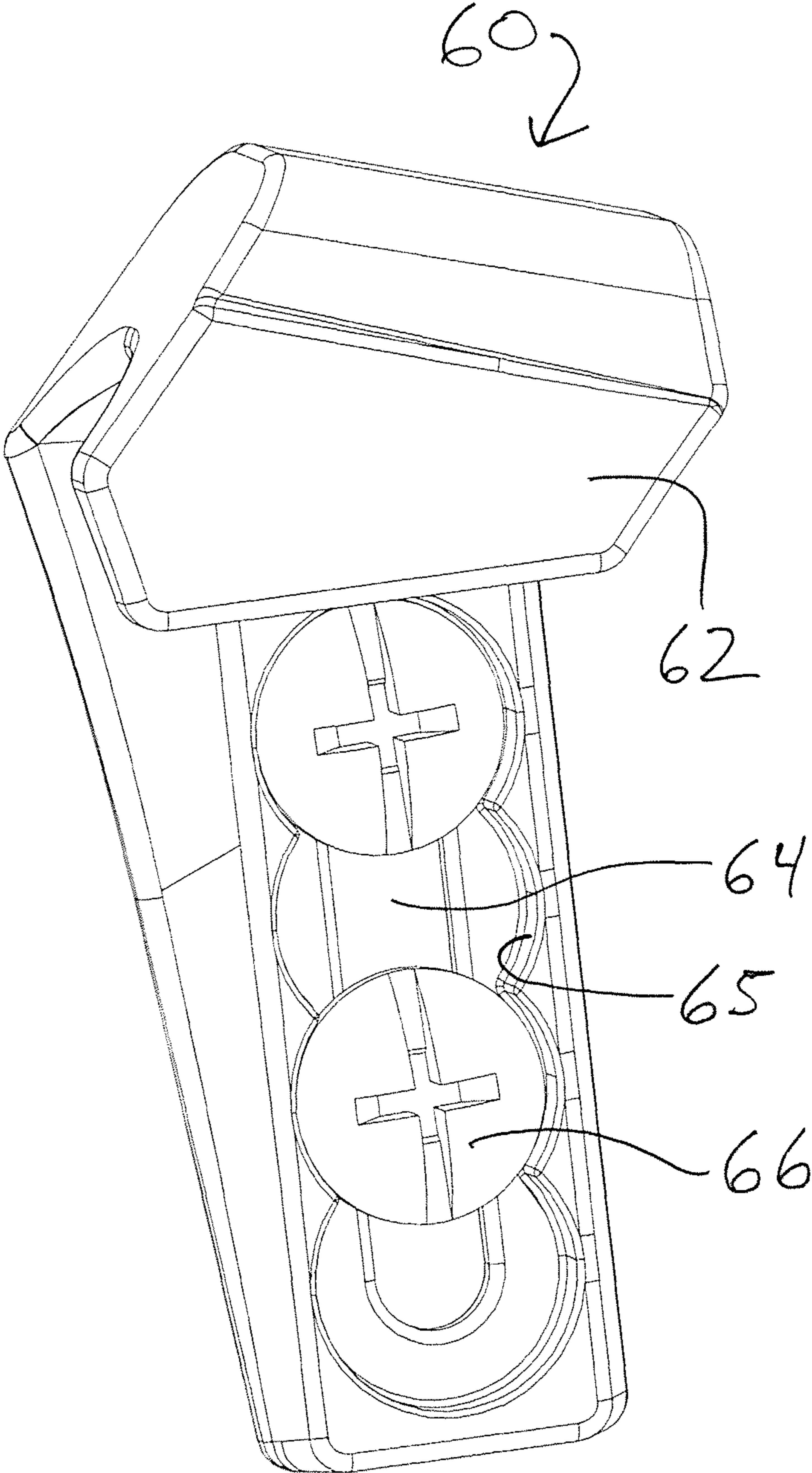

Fig. 14

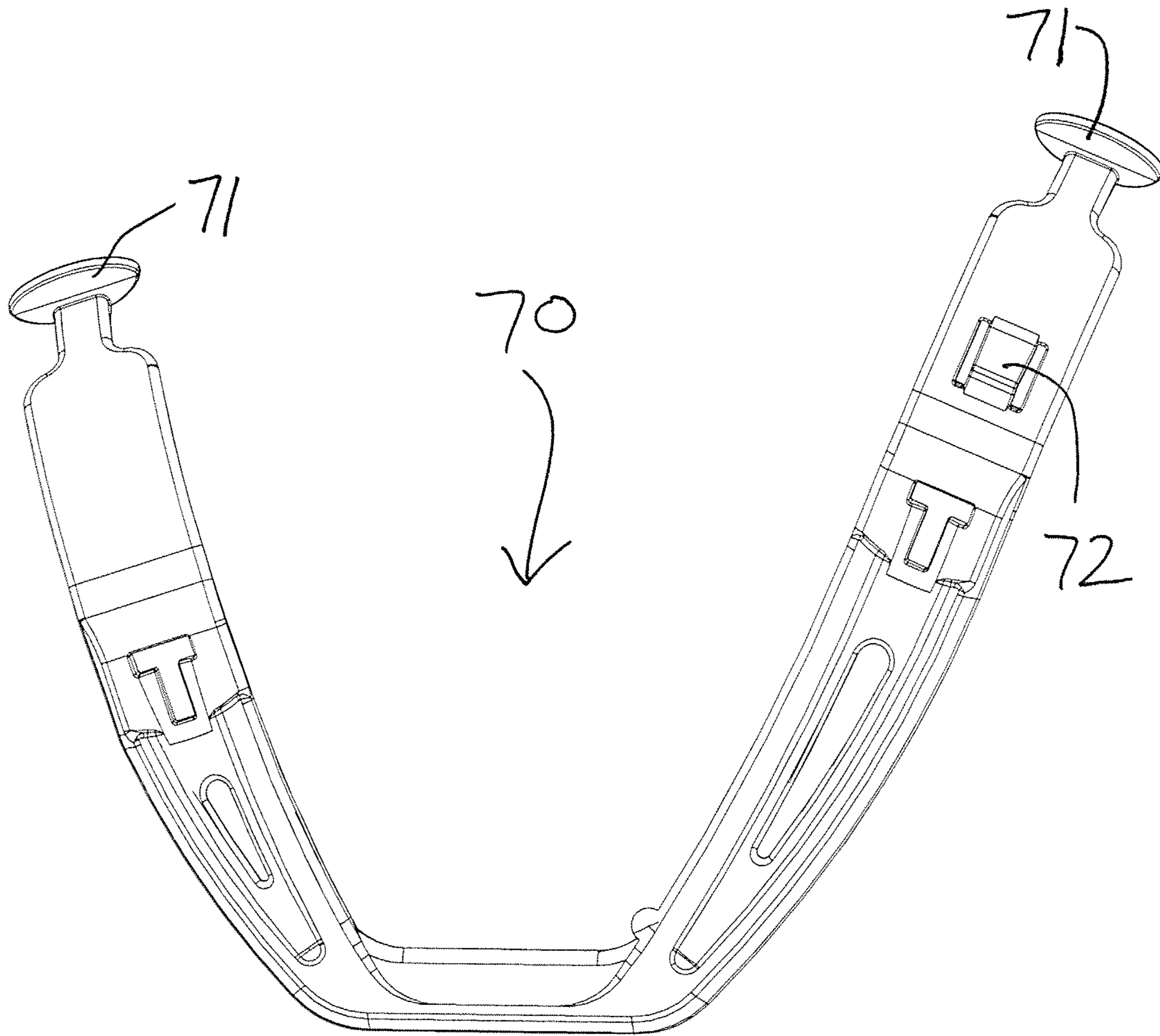

Fig. 15

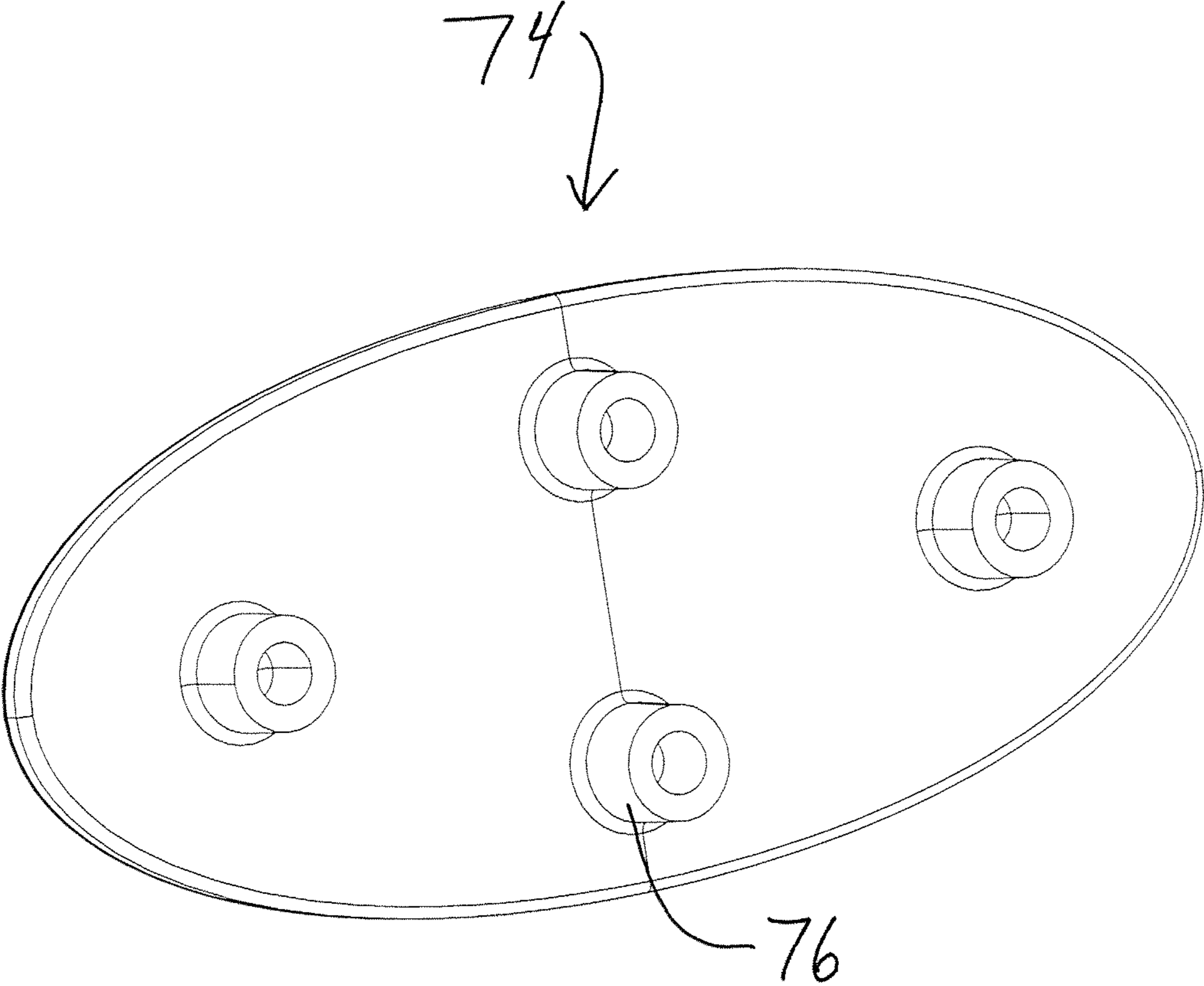

Fig. 16

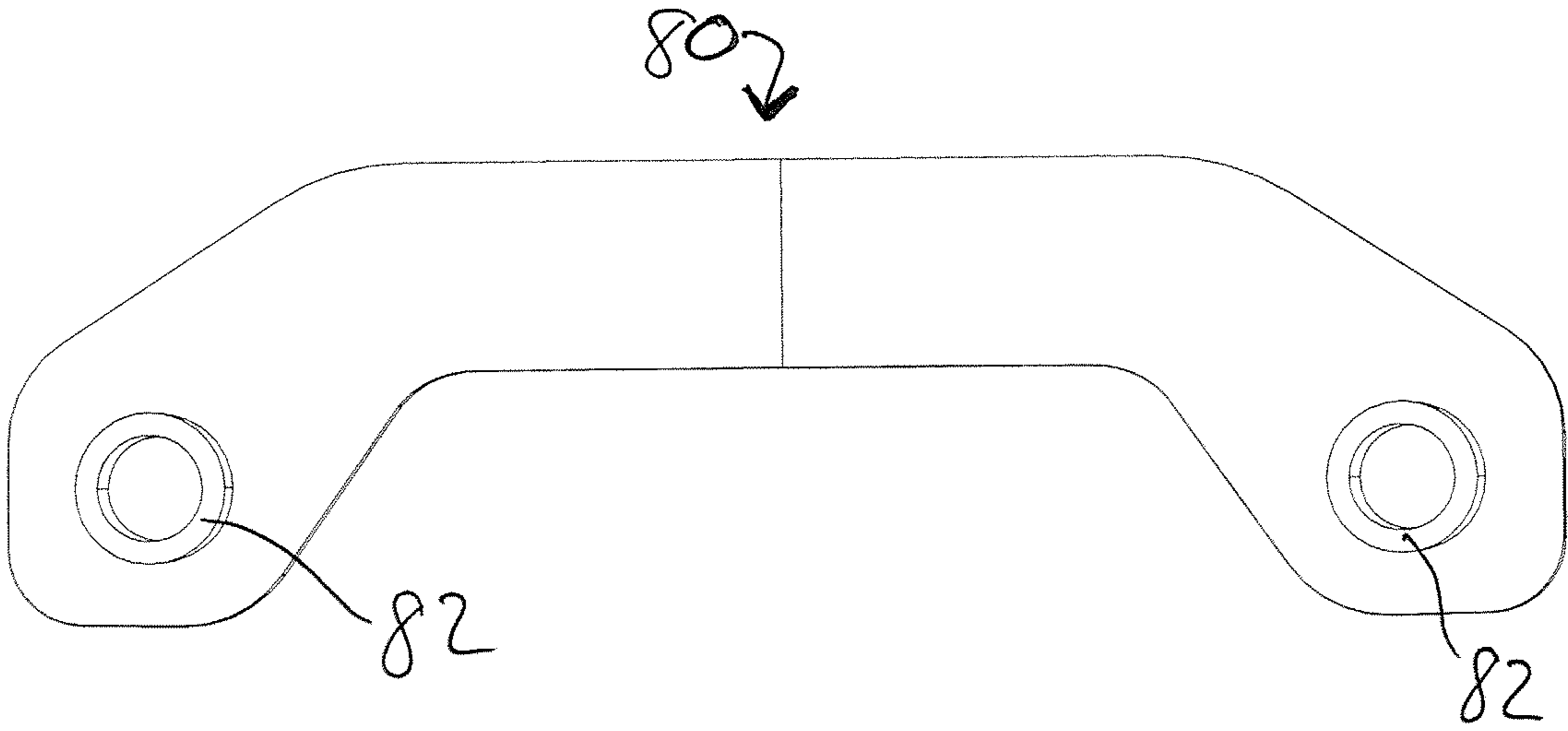

Fig. 17A

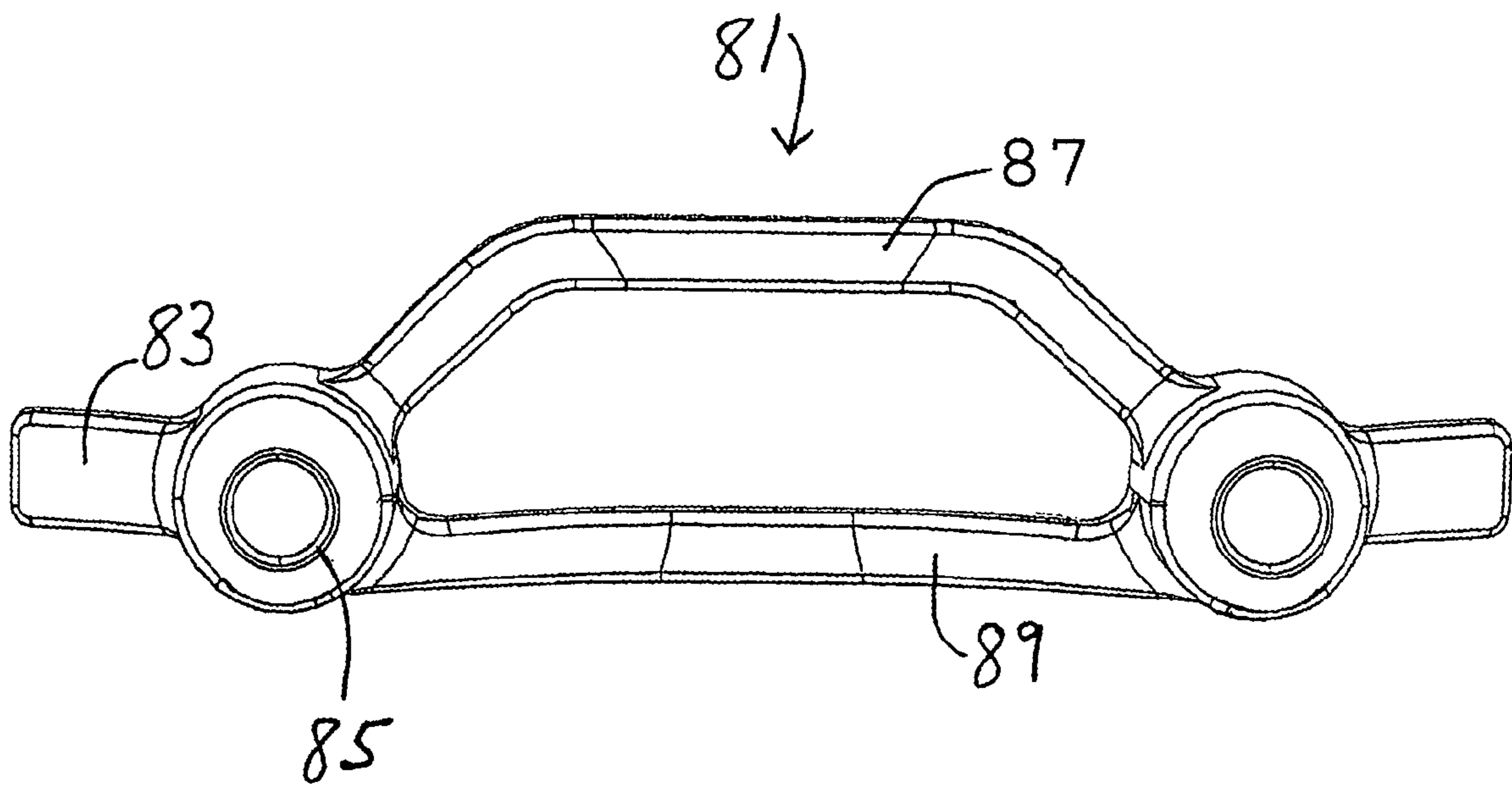
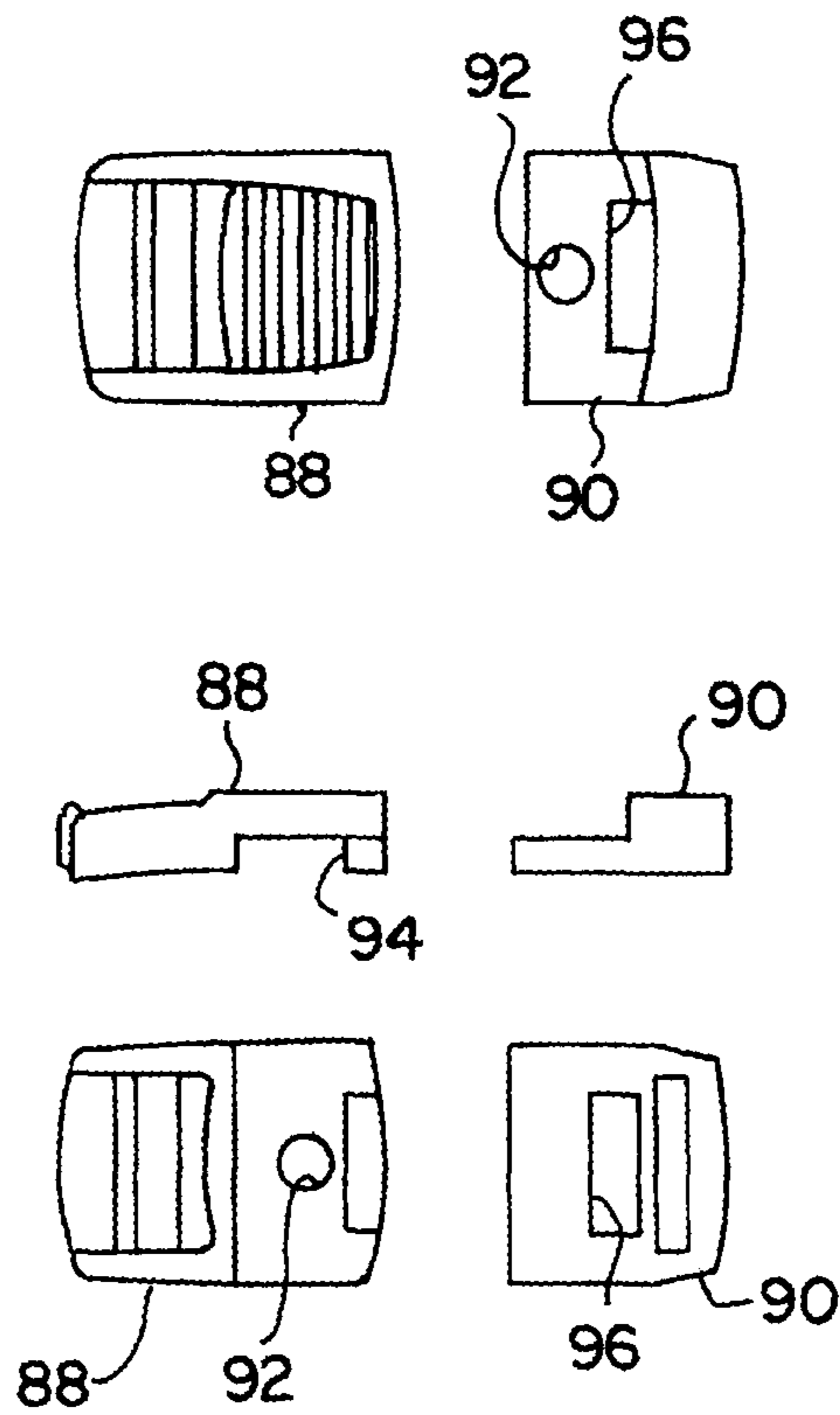
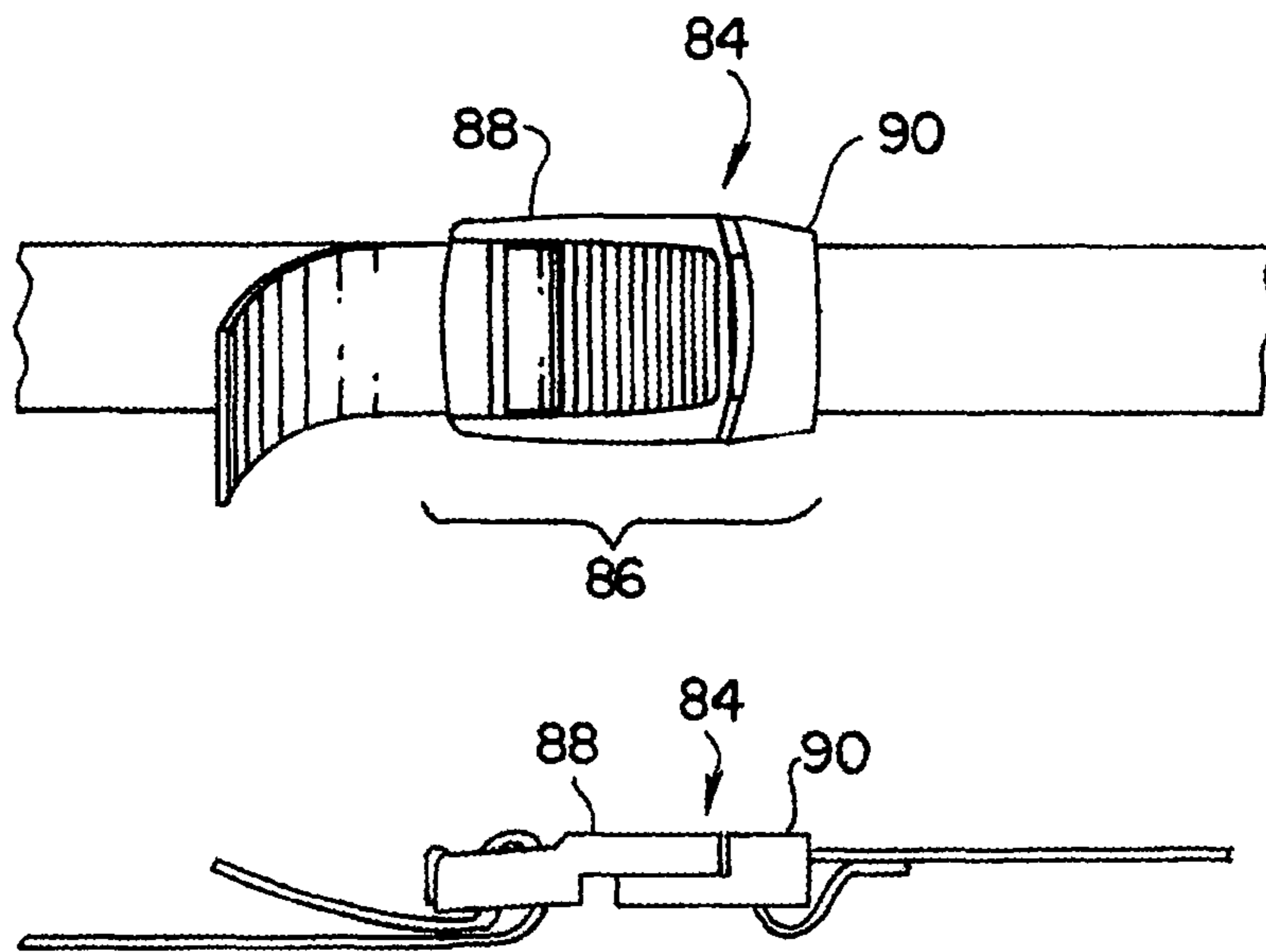
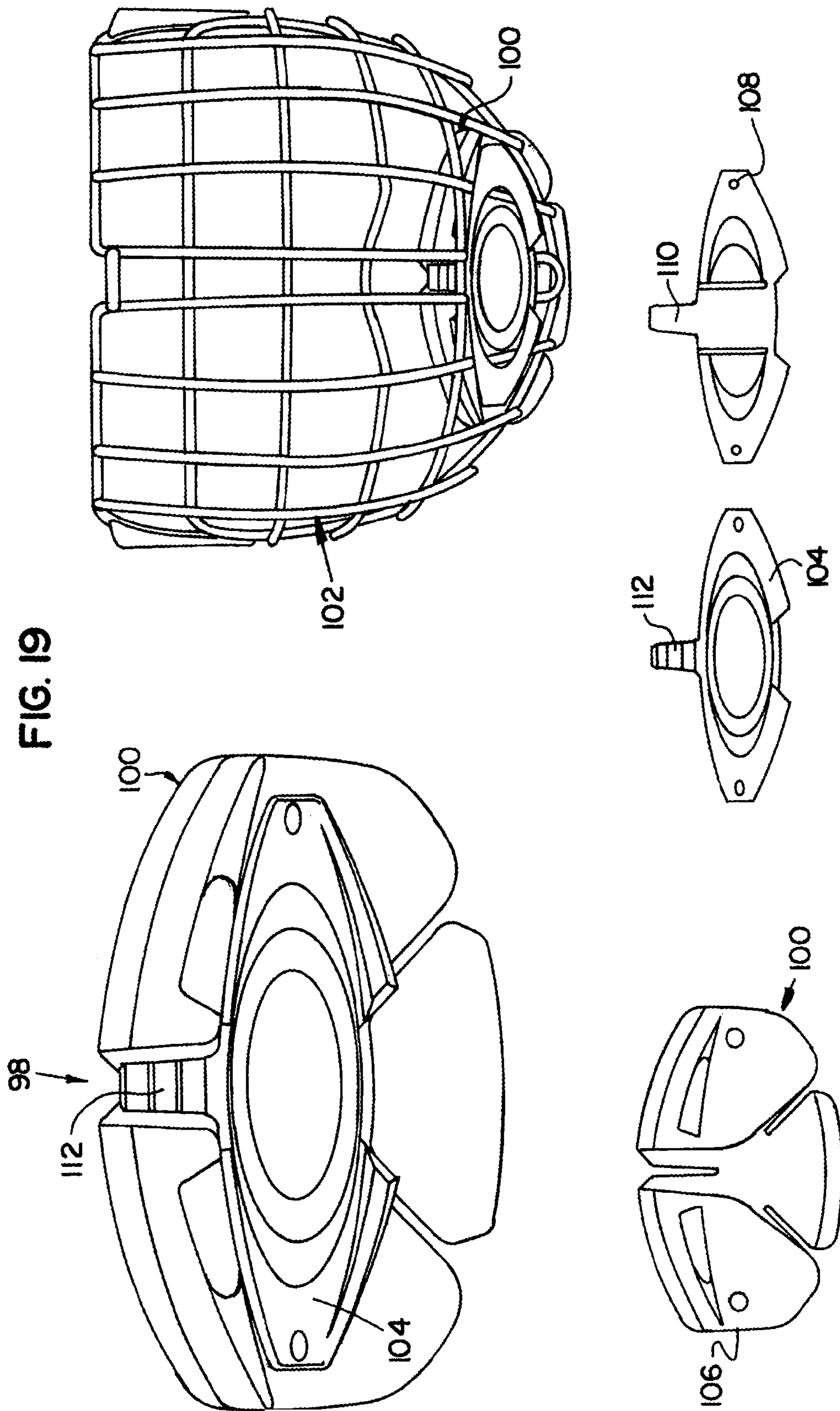

Fig. 17B

FIG. 18





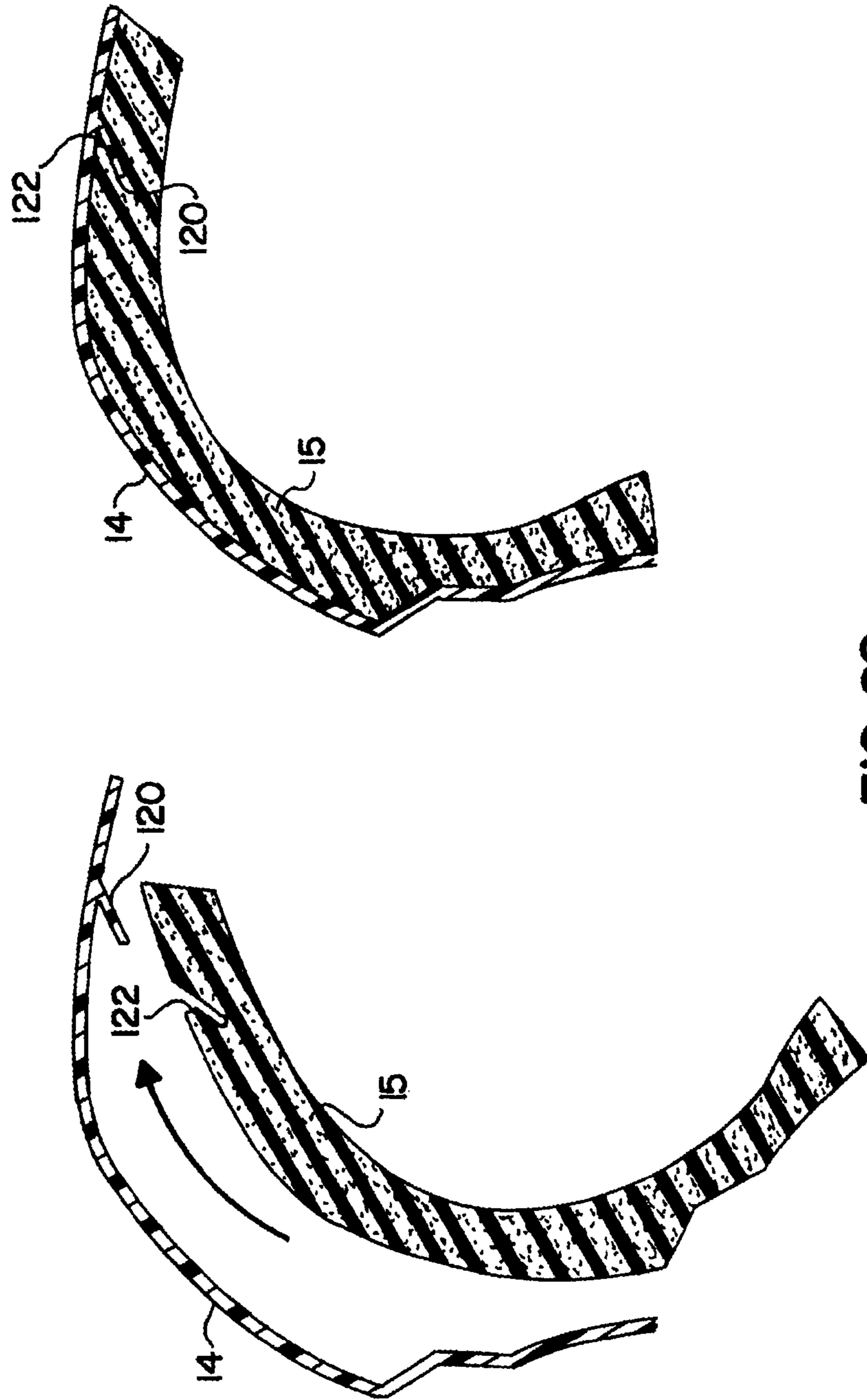

FIG. 20

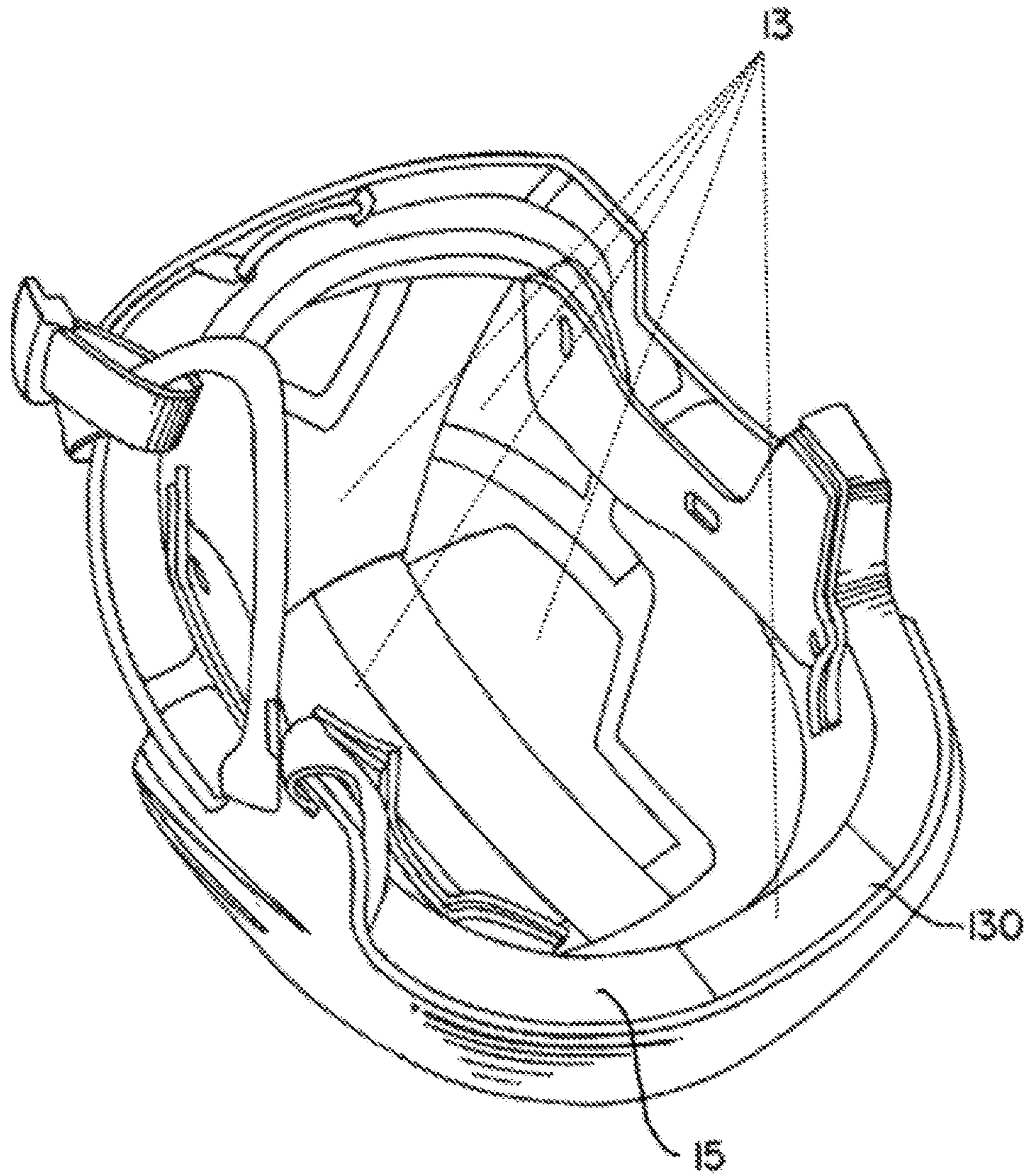

FIG. 21
Amended

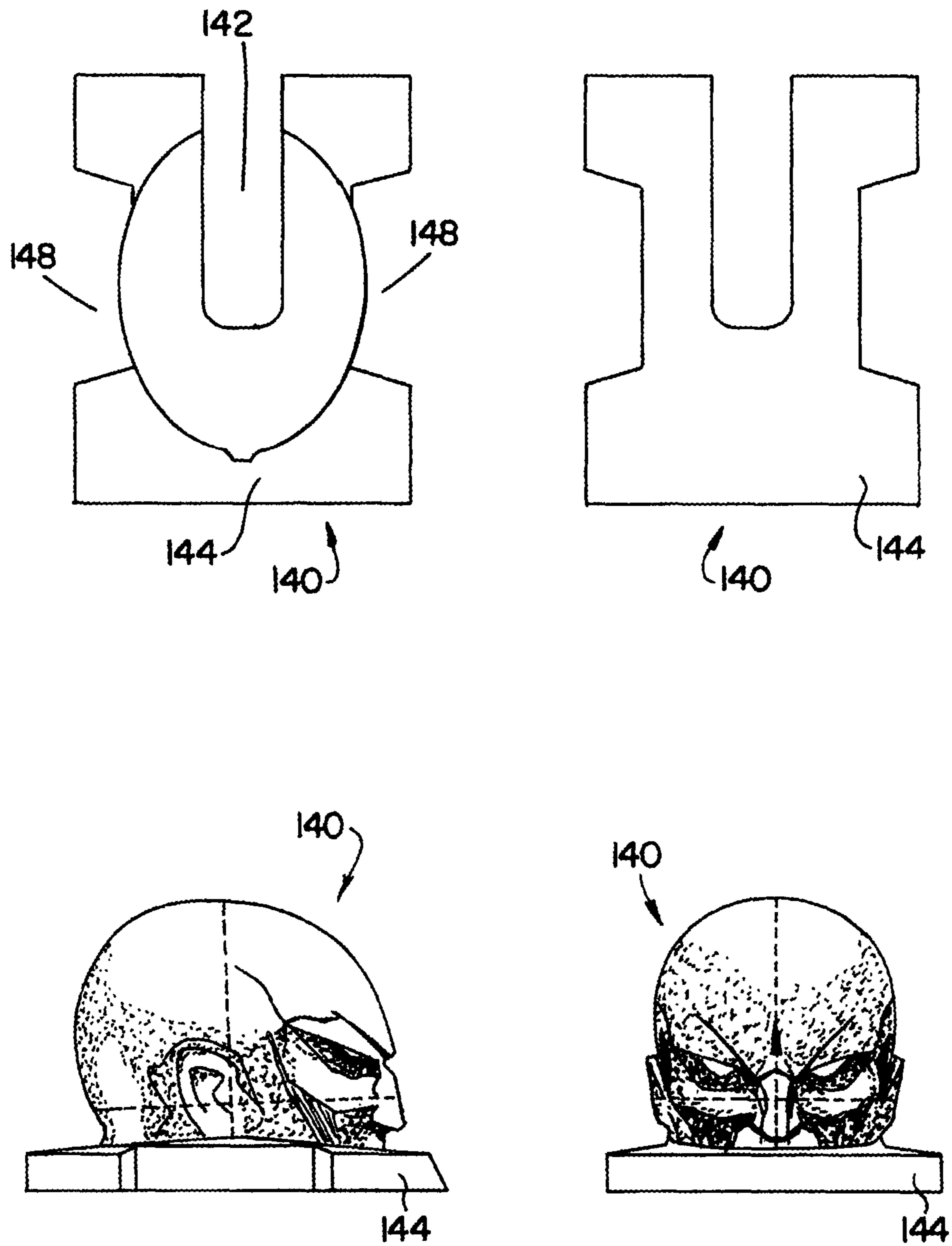

FIG. 22

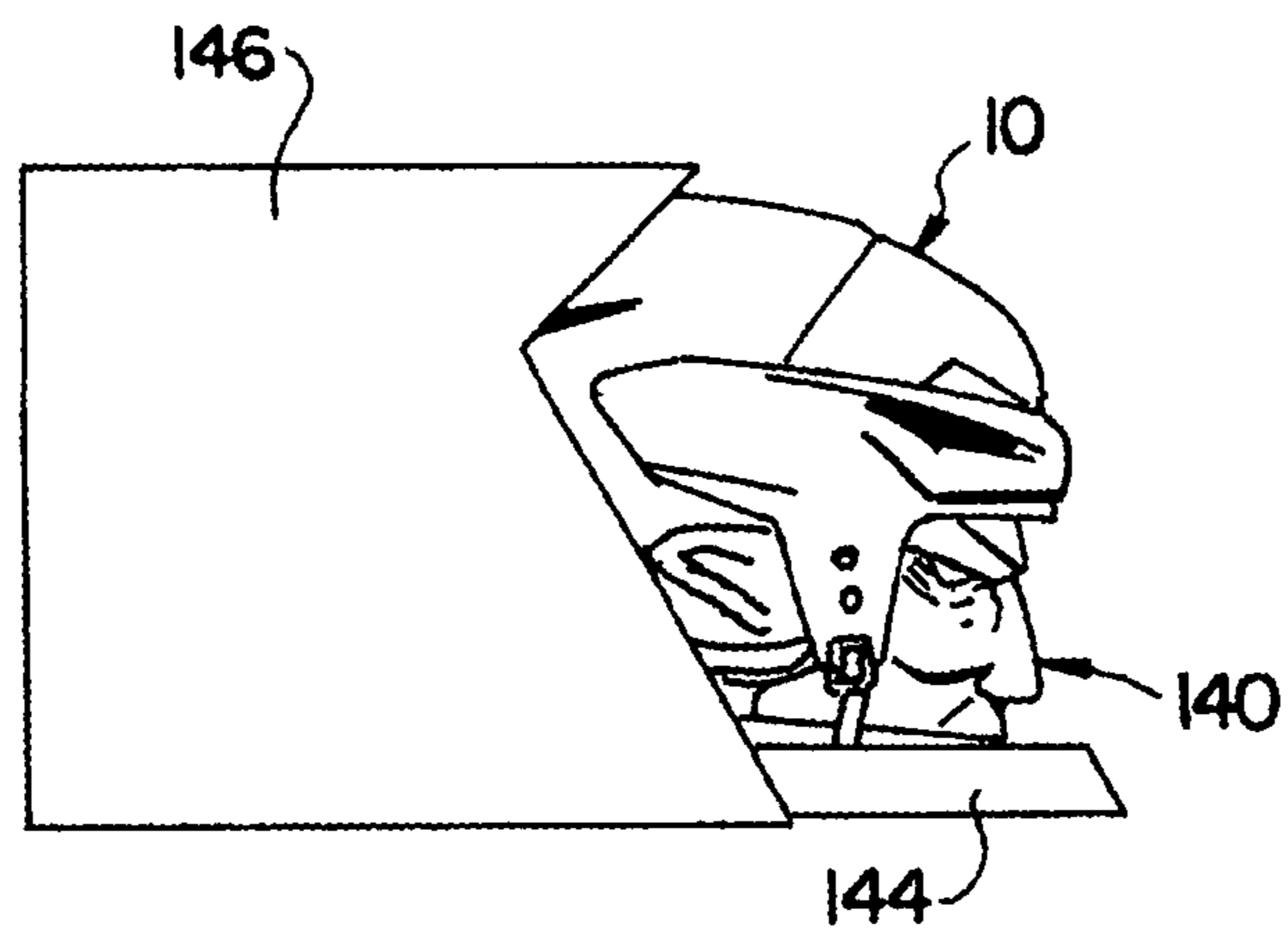

FIG. 23

ADJUSTABLE HOCKEY HELMET

Matter enclosed in heavy brackets [] appears in the original patent but forms no part of this reissue specification; matter printed in italics indicates the additions made by reissue; a claim printed with strikethrough indicates that the claim was canceled, disclaimed, or held invalid by a prior post-patent action or proceeding.

CROSS REFERENCE TO RELATED APPLICATIONS

Notice: More than one reissue application has been filed for the reissue of U.S. Pat. No. 8,832,870. The reissue applications are the present application, application Ser. No. 16/867,511, filed May 5, 2020, application Ser. No. 15/904,016, filed Feb. 23, 2018, which issued as U.S. Pat. No. RE48,048, and application Ser. No. 15/268,127, filed Sep. 16, 2016, which issued as U.S. Pat. No. RE47,747. This application is a continuation reissue of application Ser. No. 16/867,511, which is a continuation reissue of application Ser. No. 15/904,016 (now U.S. Pat. No. RE48,048), which is a continuation reissue of application Ser. No. 15/268,127 (now U.S. Pat. No. RE47,747), which is a reissue of U.S. Pat. No. 8,832,870 (application Ser. No. 13/654,260, filed Oct. 17, 2012), which is a continuation of U.S. patent application Ser. No. 12/191,000 (now U.S. Pat. No. 8,296,868), filed Aug. 13, 2008, which claims priority to U.S. Provisional Patent Application No. 60/956,621, filed Aug. 17, 2007, [both] all of which are hereby incorporated by reference.

BACKGROUND

Adjustable hockey helmets are used to accommodate various head sizes of wearers. A typical adjustable hockey helmet includes a front shell that is movable or slidable relative to a rear shell to adjust the length of the helmet. Cam mechanisms or other locking devices are commonly included on the sides of the helmet to securely engage the front shell against the rear shell to prevent longitudinal movement of the shells relative to each other once the helmet is adjusted to the desired length. While existing adjustable hockey helmets have been relatively effective, it would be advantageous to have a hockey helmet that is more readily adjustable and that can more easily be secured in place.

SUMMARY

An adjustable hockey helmet includes a front shell that is longitudinally movable relative to a rear shell to adjust the length of the helmet. One or more substantially rigid straps or similar elements are attached to the front shell and extend to the interior of the rear shell. A cam mechanism or similar device is included on the rear shell for securing the straps directly or indirectly against the interior of the rear shell to prevent longitudinal movement of the front shell relative to the rear shell once the helmet is adjusted to a desired length. Alternatively, the one or more straps may be attached to the rear shell and the cam mechanism may be included on the front shell.

Other features and advantages will appear hereinafter. The features described above can be used separately or together, or in various combinations of one or more of them.

BRIEF DESCRIPTION OF THE DRAWINGS

In the drawings, wherein the same reference number indicates the same element throughout the several views:

FIG. 1 is an exterior perspective view of an adjustable hockey helmet according to one embodiment.

FIG. 2 is an interior perspective view of the helmet shown in FIG. 1.

FIG. 3 is an interior perspective view of the helmet shown in FIGS. 1 and 2, with the interior padding removed to reveal elements positioned between the padding and the interior surface of the helmet.

FIG. 4A is a rear perspective view of the helmet shown in FIGS. 1-3 with the cam mechanism in the closed or locked position.

FIG. 4B is a side perspective view of the rear shell of the helmet shown in FIGS. 1-4 with the cam mechanism in the open or unlocked position.

FIG. 5 is a perspective view of a side plate included on the helmet shown in FIGS. 1-4.

FIG. 6 is a perspective view of a side strap of the longitudinal adjustment mechanism included in the helmet shown in FIGS. 1-4.

FIG. 7 is a perspective view of the side strap shown in FIG. 6 attached to the side plate shown in FIG. 5 with the other helmet elements removed for clarity.

FIG. 8 is a side-perspective view of a cam mechanism included in the helmet shown in FIGS. 1-4.

FIG. 9 is a rear perspective view of the cam mechanism shown in FIG. 8.

FIG. 10 is a perspective view of the longitudinal adjustment mechanism included in the helmet shown in FIGS. 1-4, including adjustment straps and the cam mechanism shown in FIGS. 8 and 9.

FIG. 11 is a perspective view of a lateral and occipital adjustment system included in the helmet shown in FIGS. 1-4.

FIG. 12 is a perspective view of the longitudinal, lateral, and occipital adjustment systems included in the helmet shown in FIGS. 1-4.

FIG. 13 is a perspective view of a height-adjustable earpiece and a clamping plate included in the helmet shown in FIGS. 1-4.

FIG. 14 is a perspective view of a height-adjustable J-clip included in the helmet shown in FIGS. 1-4.

FIG. 15 is a perspective view of an ear-loop included in the helmet shown in FIGS. 1-4.

FIG. 16 is a perspective view of an interior region of a front plate included in the helmet shown in FIGS. 1-4.

FIG. 17A is a perspective view of one embodiment of a front screw-plate that may be included in the helmet shown in FIGS. 1-4.

FIG. 17B is a perspective view of an alternative embodiment of a front screw-plate that may be included in the helmet shown in FIGS. 1-4.

FIG. 18 includes multiple perspective views of a magnetic buckle optionally included on the helmet shown in FIGS. 1-4.

FIG. 19 includes multiple perspective views of a wire facemask and height-adjustable chin cup optionally included on the helmet shown in FIGS. 1-4.

FIG. 20 includes multiple sectional views of a locking tab optionally included in the helmet shown in FIGS. 1-4.

FIG. 21 is a perspective view of a comfort nose-pad optionally included in the helmet shown in FIGS. 1-4.

FIG. 22 includes multiple views of a head-form optionally included in helmet packaging.

FIG. 23 includes multiple views of a helmet packaging assembly, including the head-form shown in FIG. 22.

DETAILED DESCRIPTION OF THE DRAWINGS

Various embodiments of the invention will now be described. The following description provides specific

details for a thorough understanding and enabling description of these embodiments. One skilled in the art will understand, however, that the invention may be practiced without many of these details. Additionally, some well-known structures or functions may not be shown or described in detail so as to avoid unnecessarily obscuring the relevant description of the various embodiments.

The terminology used in the description presented below is intended to be interpreted in its broadest reasonable manner, even though it is being used in conjunction with a detailed description of certain specific embodiments of the invention. Certain terms may even be emphasized below; however, any terminology intended to be interpreted in any restricted manner will be overtly and specifically defined as such in this detailed description section.

Where the context permits, singular or plural terms may also include the plural or singular term, respectively. Moreover, unless the word "or" is expressly limited to mean only a single item exclusive from the other items in a list of two or more items, then the use of "or" in such a list is to be interpreted as including (a) any single item in the list, (b) all of the items in the list, or (c) any combination of items in the list.

Turning now in detail to the drawings, as shown in FIGS. 1-4, one embodiment of an adjustable hockey helmet 10 includes a front shell 12 and a rear shell 14. As shown in FIG. 2, the front and rear shells 12, 14 include liners of protective padding 15 screwed, adhered, or otherwise affixed to interior surfaces of the shells 12, 14. The padding 15 may be made of a foam material, such as expanded polypropylene ("EPP"), or of any other material or combination of materials suitable for protecting a wearer's head.

The front shell 12 includes two side plates 16, which are preferably positioned in recesses in the front shell 12. As is best shown in FIG. 5, two rivets 18, or other suitable connectors, are insert-molded within (or otherwise affixed to) an inner surface of each of the side plates 16. The rivets 18 are preferably made of a metal material, such as aluminum, but may be made of any other suitable material. Any other suitable number of rivets 18 may alternatively be used.

The rivets 18 extend through aligned slots or openings 17 in the front and rear shells 12, 14. The rivets 18 are preferably press-fit into female receiving elements 22, which are molded onto or otherwise affixed to substantially rigid side straps 24, shown in FIG. 6, positioned inside the helmet 10. This press-fit relationship, shown in FIG. 7, provides an appropriate tolerance between each side plate 16 and its corresponding side strap 24 to allow the shells 12, 14 (omitted from FIG. 7 for clarity) to be longitudinally adjusted with respect to each other.

As shown in FIG. 3, the side straps 24 extend into the rear interior of the helmet 10. In one embodiment, an upper strap 26, which is ultrasonically welded or otherwise attached to an upper exterior region of the front shell 12, also extends into the rear interior of the helmet 10. The upper strap 26 is optionally attached to the front shell 12 at a location underneath a front region of the rear shell 14. The side straps 24 and the upper strap 26 may be made of nylon or polyethylene, or of any other material or combination of materials having enough strength or stiffness to prevent longitudinal adjustment of the front and rear shells 12, 14 when the straps 24, 26 are held securely in place inside the helmet 10, as further described below. While two side straps 24 and one upper strap 26 are shown, any other suitable number of straps may be used in the helmet 10. For example, in one embodiment, the upper strap 26 may be omitted such that only the side straps 24 are included.

As shown in FIG. 3, in one embodiment, one or more upper strap sleeves or strap guides 30 are attached to an upper interior surface of the rear shell 14 for guiding the upper strap 26 and maintaining it in a position close to the upper interior surface. The upper strap 26 passes through the upper strap guide 30 toward the rear interior of the helmet 10. Similarly, one or more side strap sleeves or strap guides 32 may be attached to each inner side surface of the rear shell 14 for guiding each of the side straps 24 and maintaining them close to the inner side surfaces. Each side strap 24 passes through its corresponding side strap guide 32 toward the rear interior of the helmet 10. In an alternative embodiment, a lesser or greater number of strap guides may be included, or strap guides may be omitted altogether.

As shown in FIGS. 4 and 8-10, a cam assembly 35 is included at a rear region of the rear shell 14. The cam assembly 35 includes an exterior cam handle 36 attached to a cam post 38. The cam post 38 extends through an opening in the rear shell 14 into the interior of the helmet 10. A cam plate 40 is attached to an end of the cam post 38 via a nut 41 or other suitable connector. Alternatively, the cam plate 40 may be molded or otherwise affixed to the nut 41. A connector with male threads, and a receptor with female threads, may alternatively be used in place of the nut 41 and cam post 38, respectively.

The upper strap 26 and the side straps 24 optionally each include a slot or opening 28 near their free ends. The openings 28 in each of the straps 24, 26 are positioned around the cam post 38 such that the ends of the straps 24, 26 partially overlap one another. A reinforcing plate or shim 42 is optionally positioned around the cam post 38 between the straps 24, 26 and the interior surface of the rear shell 14 to provide a clamping surface for the straps 24, 26, as well as structural support for the cam assembly 35. In one embodiment, the shim 42 is positioned within a recess in the interior surface of the rear shell 14. The shim 42 prevents transmission of excessive compressive force against the interior surface of the rear shell 14, and thus inhibits or prevents permanent compression or "creep" in the rear shell 14. If creep does occur, the nut 41 may be tightened to compensate for the creep.

The cam handle 36 is preferably rotatable between an open position in which the cam handle 36 is in a substantially horizontal position extending away from an outer surface of the rear shell 14, as shown in FIG. 4B, and a closed position in which the cam handle 36 is in a substantially vertical position against or adjacent to the outer surface of the rear shell 14, as shown in FIGS. 4A and 8-10. When in the open position, the cam handle 36 urges the cam post 38 toward the interior of the helmet 10, pushing the cam plate 40 away from the straps 24, 26 so that they are free to move or slide about the cam post 38. When in the closed position, the cam handle 36 urges the cam post 38 toward the rear of the helmet 10, pulling the cam plate 40 against the straps 24, 26. In this closed position, the cam plate 40 presses the straps 24, 26 against the shim 42 (or against the interior surface of the rear shell 14 if the shim 42 is omitted) so that they are prevented from moving or sliding about the cam post 38.

When the cam assembly 35 is in the open position, the length of the helmet 10 may be adjusted by pushing the front and rear shells 12, 14 toward each other or by pulling them away from each other. During this adjustment, the straps 24, 26 are guided via their respective strap guides 30, 32, while their openings 28 slide or move about the cam post 38. After the helmet 10 is adjusted to a desired length, the cam handle 36 may be rotated into the closed position to secure the side

5

straps **24** and the upper strap **26** against the shim **42** (or against the interior surface of the rear shell **14** if a shim **42** is omitted). When in the closed position, the rigidity or stiffness of the straps **24**, **26** prevents further longitudinal adjustment of the helmet **10**.

This single-cam system allows for faster length adjustment than the multi-cam or multi-screw systems used in many existing helmets. Furthermore, a snug fit can more readily be achieved when the helmet **10** is positioned on a wearer's head, since the wearer can use one hand to adjust and hold the helmet in place, while using the other hand to close the cam handle **36** to secure the helmet **10** in place.

In an alternative embodiment, single-screw side plates may be used to provide longitudinal helmet adjustment, instead of the strap-based, cam-lock system described above. In this embodiment, each side plate includes one insert-molded rivet on its inner surface, and an opening through which a screw or bolt may be threaded (instead of including a second rivet). In the closed or locked position, the screw or bolt is threaded through the opening in the side plate, through the front shell **12**, and into a threaded receiving element in the rear shell **14**. Alternatively, the side plate may be omitted and the screw or bolt may be threaded directly through the front shell **12** into the threaded receiving element in the rear shell **14**.

To adjust the helmet's length, a user loosens or partially unthreads the single screw in each side plate, which allows the front and rear shells **12**, **14** to be longitudinally adjusted relative to each other. Once a desired length is achieved, the user tightens the single screw in each side plate to secure the front and rear shells **12**, **14** to each other, thus preventing longitudinal movement between them. Many existing adjustable helmets, conversely, typically include two screws in each side plate (or in the helmet shells on each side of the helmet), and therefore require more time and effort to perform length adjustments.

In a related embodiment, the single screw may be replaced with a wing-nut, which may be loosened and tightened by hand. The wing-nut may include a folding or pivoting flap, which, when pivoted to the closed position, abuts or is adjacent to the helmet's surface. When the flap is pivoted to the open position, it provides enough surface area for a user to twist the wing-nut and unthread it from the receiving element in the rear shell **14**. Thus, including a wing-nut instead of a standard screw obviates the need for a screwdriver when adjusting the helmet's length.

In one embodiment, as shown in FIGS. **2**, **3**, **11**, and **12**, the helmet **10** may additionally or alternatively include a lateral and occipital adjustment system **48** configured to engage the sides and back of a wearer's head or the nape of the wearer's neck. The lateral and occipital adjustment system **48** includes one or more bands **50** or straps attached or affixed to the padding **15** (or to the front shell **12**) in the front interior region of the helmet **10**, via screws, snaps, or any other suitable connectors. The bands **50** or straps are preferably made of a relatively flexible plastic, nylon, or other suitable material.

The bands **50** or straps may be tightened or loosened, such that they are displaced laterally toward or away from the central interior of the helmet **10**, via a dial in a dial housing **52**, a knob, or another device located at a rear of the helmet **10**. The lateral and occipital adjustment system **48** also preferably includes an upper attachment portion **53** that may be attached to the liner padding **15**, or to the rear shell **14**, or to a separate attachment element **55** (see FIG. **2**), via screws, snaps, or any other suitable connectors. An occipital pad **57** or similar element is preferably attached to the dial

6

52, the straps **50**, or the attachment portion **53** for engaging the rear of a wearer's head or the nape of the wearer's neck. Any other suitable lateral and occipital adjustment system may alternatively be used in the helmet **10**.

The adjustable helmet **10** may include one or more of the longitudinal, lateral, and occipital adjustment systems described above. FIG. **12** shows the general spatial relationship between the longitudinal, lateral, and occipital adjustment systems when all are included in a helmet **10**, according to one embodiment. Variations may of course be made to the relative spacing and orientation of the various adjustment systems.

In an alternative embodiment, the various adjustment systems may be integrated with one another. For example, the longitudinal and lateral adjustment systems may be operable via a single knob and cam system. In such a system, the knob may first be rotated to adjust the longitudinal length of the front and rear shells **12**, **14**. The cam mechanism may then be moved into the locked position, after which the knob may be turned to adjust the lateral bands of the system. The reverse of this system, in which the lateral bands are adjusted when the cam is in the unlocked position, may alternatively be used. These integrated adjustment systems may be accomplished using gears associated with the cam system or using another suitable switching mechanism.

One or more of the following additional features may optionally be included in the adjustable helmet **10**. As shown in FIGS. **1** and **13**, height-adjustable earpieces **54** may be included to allow a wearer to adjust the vertical position of the earpieces **54** on the helmet **10**. An opening **56** in each earpiece is preferably positioned over a raised projection (not visible in the drawings) on an interior surface of the front shell **12**. A clamping plate **59** or similar structure, which may be a molded foam or similar material, includes threaded receiving elements **61** or other receiving elements. The clamping plate **59** is positioned behind (i.e., toward the interior of the helmet **10**) the earpiece **54** to provide a clamping force on the earpiece **54** when one or more screws or other suitable connectors are threaded into the receiving elements **61**.

The rear region of the earpiece **54** is sandwiched between the inner surface of the rear shell **14** and the liner padding **15**. The rear region of the earpiece **54** includes a slot **58** or opening that is positioned around a post-screw assembly (not visible in the drawings) used to attach the liner padding **15** to the rear shell **14**. The post-screw assembly provides a point of rotation for the earpiece **54**. To adjust the height of the earpiece **54**, a user loosens the screws in the receiving elements **61**, causing the clamping plate to release its clamping force on the earpiece **54**. The user then rotates the front region of the earpiece **54** to a desired height, after which the user tightens the screws to secure the earpiece **54** at the desired height. The raised projection positioned in the opening **56** limits the vertical movement of the earpiece **54** in the upward and downward directions by engaging the upper or lower surfaces that define the upper and lower regions of the opening **56**.

As shown in FIGS. **1** and **14**, height-adjustable J-clips **60** may optionally be included at the temple regions of the front shell **12**. Each J-clip **60** includes a hooded arm **62** or similar device for preventing an optional face protector from over-rotating into a wearer's face during impact with a puck or other object. The J-clip includes a slot **64** about which four substantially circular regions, which are defined by ridges **65**, are longitudinally arranged for receiving two screws **66** or similar connectors (or any other suitable number of screws or connectors) that are threaded into openings in the

front shell **12**. A user may adjust the vertical height of the J-clip **60** relative to the front shell **12** by partially loosening the screws **66** until the heads of the screws **66** move beyond the ridges **65**. The user then slides the J-clip **60** into the desired vertical position, after which the user re-tightens the screws **66**.

A conventional J-clip, conversely, includes four round holes into which two screws may be threaded, allowing the J-clip to be moved between the high and low positions. To move a conventional J-clip between these two positions, however, the two screws must be completely removed from the helmet shell, then re-inserted and re-tightened once the J-clip's position has been adjusted. Thus, the slotted configuration shown in FIGS. **1** and **14** allows for more efficient adjustment of the J-clip **60**.

In an alternative embodiment, the recessed slot may include longitudinal ridges instead of ridges **65** that define substantially circular regions. In such an embodiment, the screws **66** must be adequately tightened to prevent vertical movement of the J-clip **60** without the aid of the circular regions. In another alternative embodiment, a horizontal divider, which divides the slot **64** into two separate vertical slotted regions, may be included to provide additional strength to the J-clip **60**.

As shown in FIGS. **1** and **15**, ear-loops **70** are preferably attached to the front and rear shells **12**, **14** on each side of the helmet **10**. The ear-loops **70** include enlarged end portions **71** that are insertable through slots or openings in the front and rear shells **12**, **14** for securing the ear-loops **70** to the helmet **10**. The rear portion (or front portion) of each ear-loop **70** includes a raised ledge **72**, bead, or similar feature that snaps into or squeezes through the slot in the rear shell **14** (or the front shell **12**) when the ear-loop **70** is rotated into an up position, thus maintaining the ear-loop **70** in an up position. Players often like to flip up their ear-loops during warm-ups and in between periods. Conventional ear-loops, however, typically do not remain in the up position because they do not include a mechanism for maintaining the ear-loop in the up position.

As shown in FIGS. **1** and **16**, a front plate **74**, which may be made of a nylon material or other similar material, includes a plurality of posts **76** injection-molded or otherwise integrated onto its rear surface. The front-facing region of the front shell **12** includes a recessed area including corresponding openings into which the posts **76** may be inserted. The posts **76** are optionally heat-staked into the openings to permanently attach them to the front shell **12**. A bubble logo or other decorative element may be adhered or otherwise affixed to the front surface of the front plate **74**. Because the front surface of the front plate **74** is made of a nylon or similar material, as opposed to polyethylene, the logo or decorative element can be securely glued to the front plate **74**.

As shown in FIGS. **1** and **17A**, a front screw-plate **80** may be included for securing the front shell **12** to the liner padding **15**. The screw-plate **80** includes two circular, threaded receiving elements **82** molded on or otherwise integrated thereon. The front shell **12** includes two circular openings in which the receiving elements **82** are positioned.

The screw-plate **80** is directly or indirectly affixed to a portion of the front liner padding **15**. In one embodiment, a stiff fabric material is sandwiched between the screw plate **80** and the interior surface of the front shell **12**. The stiff fabric material has a greater surface area than, and therefore extends beyond the boundaries of, the screw plate **80**. The liner padding **15** may be adhered or otherwise affixed to the stiff fabric material. Screws **78** or bolts are threaded from the

exterior of the front shell **12** into the receiving elements **82** to secure the fabric material between the front shell **12** and the screw-plate **80**.

FIG. **17B** illustrates an alternative embodiment of a screw plate **81** including lateral flanges **83** positioned adjacent to two circular, threaded receiving elements **85**. The screw plate **81** may be a unitary piece or may include one or more support arms, such as the upper support arm **87** and the lower support arm **89** shown in FIG. **17B**. The screw plate **81** is preferably embedded within a front region of the liner padding **15**. The receiving elements **85** protrude out of the liner padding **15** and are positioned in the circular openings in the front shell **12** for receiving the screws **78** or bolts.

During threading of the screws **78** or bolts, the receiving elements **82** or **85** are prevented from rotating due to their connection via the screw-plate **80** or **81** in conjunction with their positioning in the shell openings. Many existing helmets, conversely, use individual, non-circular receiving elements that fit into non-circular holes in the helmet shell. The receiving elements are non-circular to prevent them from rotating within the shell openings when screws or bolts are threaded into the non-circular receiving elements. Thus, by incorporating a single, integrated screw-plate **80** or **81**, circular receiving elements **82** or **85** may be used to secure the front shell **12** to the liner padding **15**.

As shown in FIG. **18**, a chin strap **84**, which may be attached at its free ends to the ear-loops **70** or to other suitable helmet regions, includes a magnetic buckle **86**. The buckle **86** includes a first component **88** and a second component **90**, each including a magnet **92** insert-molded thereon or otherwise affixed thereto.

The first and second components **88**, **90** preferably include first and second walls **94**, **96**, respectively, each oriented substantially perpendicularly to the face onto which its respective magnet **92** is molded. The first and second walls **94**, **96** engage each other when the first and second components **88**, **90** are magnetically coupled to each other. This wall arrangement prevents the first and second components from readily disengaging from each other when the chin-strap is pulled in tension. The first and second walls **94**, **96**, in conjunction with the magnets **92**, are optionally configured in a manner that allows the first and second components **88**, **90** to disengage from each other when a predetermined amount of tensile force is applied to the chin strap **84**. The magnetic buckle **86** is substantially easier to connect and disconnect than are traditional snap-fit arrangements.

As shown in FIG. **19**, a chin-cup assembly **98** for use on an optional wire cage facemask **102** includes a chin cup **100** and a chin cup retainer **104**. The chin cup **100** may be injection-molded, compression-molded, or otherwise formed, and optionally includes female receiving elements **106** molded therein. The retainer **104** optionally includes corresponding insert-molded male snaps **108** or rivets (the male and female elements could of course be reversed). The chin cup **100** and the retainer **104** may be press-fit together or otherwise attached to each other around the wires of the facemask **102**.

An integral, vertically extending indexing arm **110** is optionally included on the retainer **104**. The indexing arm **110** includes horizontal grooves **112** that can snap over the horizontal wires on the facemask **102**. To adjust the height of the chin cup **100**, a user slides the chin cup assembly **98** to a desired height on the facemask **102**, allowing a wire to snap into one of the horizontal grooves **112**. Thus, the chin cup assembly **98** can be secured in a desired location, and

does not have to be removed from the facemask **102** to have its vertical position adjusted on the facemask **102**.

As shown in FIG. **20**, a substantially rear-projecting tab **120** or similar element may be included on the interior surface of the rear shell **14** for engaging a corresponding slot **122** in the liner padding **15**. The tab **120** substantially prevents the padding **15** from rotating in a forward direction, which is often an issue with existing helmets. In an alternative embodiment, the tab **120** may be included on the upper strap guide **30**, which is secured to the upper interior surface of the rear shell **14**.

As shown in FIG. **21**, the helmet **10** may include a plurality of comfort pads **13** arranged to contact different portions of the wearer's head when the helmet is worn. For example, a comfort pad **130** made of a soft foam or other soft material may be included at the front of the helmet **10** to provide a soft engagement surface, when the helmet is rotated forward, for a wearer's nose. As shown in FIG. **21**, the front comfort pad **130** is wrapping around the lower front edge of the liner padding **15**. A channel is optionally created in the lower front edge of the liner padding **15** for receiving the comfort pad **130**, which may be adhered or otherwise affixed to the liner padding or to the front shell **12**.

As shown in FIGS. **22** and **23**, a head-form **140** may be included as part of the helmet's packaging. The head-form **140** may be made of expanded polystyrene (EPS) or of another suitable material. The head-form **140** preferably includes a base region **144** configured to fit within a packaging box **146**. The base region **144** preferably includes side openings **148** to accommodate the ear-loops **70** and the chin strap **84** of the helmet **10**.

The head-form **140** substantially fills the interior of the helmet **10** and substantially prevents the liner padding **15** from being dented or damaged during shipping and handling. The liner padding in many existing helmets, conversely, often becomes marked or dented because the padding is exposed during shipping and while the helmet rests on a shelf.

The head-form **140** preferably includes a slot **142** or opening in its rear upper region, or in another suitable location. The slot **142** provides flexibility so that the head-form **140** may accommodate different helmet sizes. For example, when a medium helmet is placed over the head-form **140**, the sides of the head-form **140** are pressed toward each other such that the slot **142** is narrowed. When a small helmet is placed over the head-form **140**, the sides of the head-form **140** are pressed toward each other to a greater degree such that the slot **142** is narrowed even further. Accordingly, the head-form **140** may be snugly secured within helmets of various sizes.

The various helmet components described herein, if not otherwise specified, may be made of any suitable material or combination of materials. While specific elements are often described above, in many cases, other suitable elements may be used in their place (e.g., wing-nuts may be used instead of screws, where applicable).

Any of the above-described embodiments may be used alone or in combination with one another. Furthermore, the adjustable helmet may include additional features not described herein. While several embodiments have been shown and described, various changes and substitutions may of course be made, without departing from the spirit and scope of the invention. The invention, therefore, should not be limited, except by the following claims and their equivalents.

What is claimed is:

[1. An adjustable helmet, comprising:

- a first shell;
- padding attached to the first shell;
- a second shell engaged with the first shell;
- a plurality of substantially rigid straps connected to the first shell and extending into the second shell;
- a cam assembly on the second shell in engagement with the straps, wherein the straps are movable relative to the cam assembly, and the cam assembly includes a cam handle that is pivotable between:
 - an open position in which the straps are free to move through the cam assembly, such that the first shell may be longitudinally adjusted relative to the second shell; and
 - a closed position in which the straps are prevented from moving through the cam assembly, such that the first shell is prevented from being longitudinally adjusted relative to the second shell.]

[2. The helmet of claim **1** wherein the first shell is a front shell and the second shell is a rear shell, or the first shell is a rear shell and the second shell is a front shell.]

[3. The helmet of claim **1** further comprising a lateral adjustment mechanism including a plurality of bands attached directly or indirectly to the first shell or the second shell, wherein the bands are configured to engage sides of a wearer's head.]

[4. The helmet of claim **3** wherein the lateral adjustment mechanism further includes a device for tightening and loosening the bands.]

[5. The helmet of claim **3** further comprising a pad attached to the lateral adjustment mechanism for engaging an occipital portion of a wearer's head.]

[6. The helmet of claim **1** further comprising a height-adjustable earpiece on the helmet.]

[7. The helmet of claim **1** further comprising a height-adjustable J-clip attached to the first shell via at least one threaded connector, with the J-clip including a slot positioned around the threaded connector for allowing the J-clip to be vertically adjusted relative to the first shell when the threaded connector is loosened without requiring removal of the threaded connector from the first shell.]

[8. The helmet of claim **1** further comprising an ear loop including a raised ledge configured to pass through a slot in the helmet and to engage an inner surface of the helmet to maintain the ear loop in an upward position.]

[9. The helmet of claim **1** further comprising padding in an interior of the second shell, and a rear-projecting tab on an interior surface of the second shell that engages a slot in the padding to prevent rotation of the padding.]

[10. An adjustable helmet, comprising:

- a first shell;
- a second shell engaged with the first shell;
- a plurality of substantially rigid straps connected to the first shell and extending into an interior region of the second shell, with each of the straps including an opening;
- a cam assembly attached to an exterior region of the second shell, the cam assembly including a cam post extending into the interior region of the second shell and through the openings in the straps, and a cam plate on the cam post;

wherein the cam assembly is movable between:

- a closed position in which the cam plate secures the straps against the second shell, such that the first shell is prevented from being longitudinally adjusted relative to the second shell, and

11

an open position in which the straps are free to move about the cam post such that the first shell may be longitudinally adjusted relative to the second shell.]

[11. The helmet of claim 10 wherein the first shell is a front shell and the second shell is a rear shell, or the first shell is a rear shell and the second shell is a front shell.]

[12. An adjustable helmet, comprising:

a first shell;

padding attached to the first shell;

a second shell engaged with the first shell;

a plurality of substantially rigid straps connected to the first shell and extending into the second shell;

a cam assembly on an exterior region of the second shell in engagement with the plurality of straps, wherein the cam assembly is not engageable with the first shell.]

[13. An adjustable helmet, comprising:

a front shell;

padding attached to the front shell;

a rear shell engaged with the front shell;

at least one substantially rigid strap attached to the front shell and extending into the rear shell; and

a cam assembly on an exterior region of the rear shell that is engageable with the strap, wherein the cam assembly includes a cam handle that is pivotable between an open position and a closed position.]

[14. The helmet of claim 13 wherein the strap is attached to an upper region of the front shell such that, in use, the strap overlies the top of a wearer's head.]

[15. The helmet of claim 13 wherein engagement of the cam assembly with the strap substantially prevents longitudinal adjustment of the front shell relative to the rear shell.]

[16. The helmet of claim 13 wherein the cam assembly is located on a rear-exterior region of the rear shell.]

[17. The helmet of claim 13 wherein the strap comprises at least one opening engageable by the cam assembly.]

[18. An adjustable helmet, comprising:

a first shell;

padding attached to the first shell;

a second shell engaged with the first shell;

at least one substantially rigid strap attached to the first shell and extending into the second shell, wherein the strap is contained within the interior of the helmet; and means for engaging the strap to substantially prevent longitudinal movement of the first shell relative to the second shell, wherein the means for engaging is located on a rear exterior region of the second shell.]

19. An adjustable helmet, having a front region, a rear region, and generally opposite side regions, the helmet comprising:

a) an external protective shell circumscribing an inside region for receiving a wearer's head;

b) interior padding residing between the protective shell and the head of the wearer when the helmet is being worn, the interior padding comprising:

i) liner padding attached to the protective shell, wherein a recess is defined in a lower front edge of the liner padding in the front region of the helmet; and

ii) comfort padding arranged to be disposed between the liner padding and the wearer's head when the helmet is worn, wherein the comfort padding comprises a front comfort pad received by the recess in the lower front edge of the liner padding in the front region of the helmet.

20. The adjustable helmet as defined in claim 19, wherein the recess comprises a channel formed in the lower front edge of the liner padding.

12

21. The adjustable helmet as defined in claim 20, wherein the liner padding has an outer face oriented towards the external protective shell and an inner face oriented toward the wearer's head, and wherein the channel defined in the lower front edge of the liner padding extends between the inner and outer faces of the liner padding in the front region of the helmet.

22. The adjustable helmet as defined in claim 19, wherein the front comfort pad wraps around the lower front edge of the liner padding.

23. The adjustable helmet as defined in claim 22, wherein the front comfort pad is affixed to the liner padding.

24. The adjustable helmet as defined in claim 19, further comprising:

c. a fit adjustment system, including:

i. a pair of elongated members, each elongated member extending along a respective side region of the helmet toward the front region thereof;

ii. a manually operable mechanism located in the rear region of the helmet, the pair of elongated members projecting from opposite sides of the manually operable mechanism;

iii. each of the first and the second elongated members including:

a front connection area at which the elongated member connects to the adjustable helmet;

a rear connection area at which the elongated member connects to the manually operable mechanism;

iv. the manually operable mechanism being operable by the wearer to selectively tighten or loosen the elongated members to adjust a fit of the adjustable helmet.

25. The adjustable helmet as defined in claim 24, wherein the front connection area of each of the first and the second elongated members is fastened to the liner padding.

26. The adjustable helmet as defined in claim 24, wherein each of the first and the second elongated members is at least partially covered by a portion of the comfort padding that is located between the elongated member and the wearer's head when the helmet is worn.

27. The adjustable helmet as defined in claim 24, wherein the comfort padding comprises a plurality of comfort pads arranged to contact different portions of the wearer's head when the adjustable helmet is worn.

28. The adjustable helmet as defined in claim 27, wherein the comfort padding comprises an occipital pad configured to engage an occipital region of the wearer's head.

29. The adjustable helmet as defined in claim 28, wherein the fit adjustment system further comprises an attachment portion connected to the manually operable mechanism and extending upwardly therefrom to connect the manually operable mechanism to a portion of the helmet that is located above the manually operable mechanism.

30. The adjustable helmet as defined in claim 29, wherein the manually operable mechanism includes a dial mounted in a dial housing.

31. The adjustable helmet as defined in claim 30, wherein the occipital pad is mounted to the dial housing.

32. The adjustable helmet as defined in claim 29, wherein the upwardly extending attachment portion includes a plurality of arms connecting the manually operable mechanism to the portion of the helmet located above the manually operable mechanism.

33. The adjustable helmet as defined in claim 32, wherein the attachment portion extends upwardly from the manually

operable mechanism to connect the manually operable mechanism to the liner padding.

34. The adjustable helmet as defined in claim 33, wherein the plurality of arms include a first arm and a second arm that extend upwardly and meet at a common point of connection that is fastened to the liner padding.

35. The adjustable helmet as defined in claim 24, wherein the first and the second elongated members are formed from nylon.

36. The adjustable helmet as defined in claim 24, wherein the front connection areas of the first and the second elongated members are located at or near temple regions on the first and the second side regions of the adjustable helmet.

37. The adjustable helmet as defined in claim 24, wherein the external protective shell includes a rear portion facing a rear region of the wearer's head when the helmet is worn, wherein a portion of the manually operable mechanism resides in an interior region of the adjustable helmet between the rear portion and the wearer's head when the helmet is worn.

38. The adjustable helmet as defined in claim 24, wherein the manually operable mechanism is the sole actuator to perform an adjustment of a dimension of the inside region to adjust a fit of the adjustable helmet.

39. An adjustable helmet, having a front region, a rear region, and generally opposite side regions, the helmet comprising:

a. an external protective shell circumscribing an inside region for receiving a wearer's head;

b. interior padding residing between the protective shell and the head of the wearer when the helmet is being worn, the interior padding comprising:

i. liner padding attached to the protective shell, wherein a channel is defined along a surface of the liner padding in the front region of the helmet; and
ii. comfort padding arranged to contact the wearer's head when the helmet is worn;

c. a fit adjustment system, the fit adjustment system comprising:

iii. a manually operable mechanism in the inside region and facing a rear portion of the wearer's head when the helmet is worn;

iv. a pair of elongated members, the elongated members projecting from opposite sides of the manually operable mechanism toward respective side regions of the helmet and each elongated member extending along a respective side region of the helmet toward the front region thereof, wherein a front portion of the comfort padding is disposed over the channel in the liner padding in the front region of the helmet, and a rear portion of the comfort padding is disposed between the manually operable mechanism and the rear portion of the wearer's head when the helmet is worn;

v. the manually operable mechanism being operable by the wearer to selectively tighten or loosen the elongated members to adjust a fit of the adjustable helmet.

40. The adjustable helmet as defined in claim 39, wherein the comfort padding comprises a plurality of comfort pads arranged to contact different portions of the wearer's head when the adjustable helmet is worn.

41. The adjustable helmet as defined in claim 40, wherein the front portion of the comfort padding comprises a front comfort pad arranged to contact a front portion of the wearer's head when the helmet is worn.

42. The adjustable helmet as defined in claim 40, wherein the rear portion of the comfort padding comprises an occipital pad configured to engage an occipital region of the wearer's head.

43. The adjustable helmet as defined in claim 42, wherein the fit adjustment system further comprises an attachment portion connected to the manually operable mechanism and extending upwardly therefrom to connect the manually operable mechanism to a portion of the helmet that is located above the manually operable mechanism.

44. The adjustable helmet as defined in claim 43, wherein the manually operable mechanism includes a dial mounted in a dial housing.

45. The adjustable helmet as defined in claim 44, wherein the occipital pad is mounted to the dial housing.

46. The adjustable helmet as defined in claim 43, wherein the upwardly extending attachment portion includes a plurality of arms connecting the manually operable mechanism to the portion of the helmet located above the manually operable mechanism.

47. The adjustable helmet as defined in claim 39, wherein each of the first and the second elongated members includes: a front connection area at which the elongated member connects to the adjustable helmet;

a rear connection area at which the elongated member connects to the manually operable mechanism.

48. The adjustable helmet as defined in claim 47, wherein the front connection area of each of the first and the second elongated members is fastened to the liner padding.

49. The adjustable helmet as defined in claim 39, wherein the front connection areas of the first and the second elongated members are located at or near temple regions on the first and the second side regions of the adjustable helmet.

50. The adjustable helmet as defined in claim 39, wherein the external protective shell includes a rear portion facing a rear region of the wearer's head when the helmet is worn, wherein a portion of the manually operable mechanism resides in an interior region of the adjustable helmet between the rear portion and the wearer's head when the helmet is worn.

51. The adjustable helmet as defined in claim 39, wherein the manually operable mechanism is the sole actuator to perform an adjustment of a dimension of the inside region to adjust a fit of the adjustable helmet.