



US00RE49488E

(19) **United States**
(12) **Reissued Patent**
De Boer et al.

(10) **Patent Number:** **US RE49,488 E**
(45) **Date of Reissued Patent:** ***Apr. 11, 2023**

(54) **LITHOGRAPHY SYSTEM, METHOD OF CLAMPING AND WAFER TABLE**

(58) **Field of Classification Search**
CPC .. G03F 7/707; G03F 7/70691; G03F 7/70875;
G03F 7/70783

(71) Applicant: **ASML Netherlands B.V.**, Veldhoven (NL)

See application file for complete search history.

(72) Inventors: **Guido De Boer**, GP Someren (NL);
Michel Pieter Dansberg, HP Berkel en Rodenrijs (NL); **Pieter Kruit**, EB Delft (NL)

(56) **References Cited**

U.S. PATENT DOCUMENTS

4,918,870 A 4/1990 Torbert
4,944,645 A 7/1990 Suzuki
(Continued)

(73) Assignee: **ASML Netherlands B.V.**, Veldhoven (NL)

FOREIGN PATENT DOCUMENTS

(*) Notice: This patent is subject to a terminal disclaimer.

CN 1364679 8/2002
CN 1614511 A 5/2005
(Continued)

(21) Appl. No.: **16/427,295**

OTHER PUBLICATIONS

(22) Filed: **May 30, 2019**

Notice of Allowance in U.S. Appl. No. 14/135,378 dated Dec. 23, 2016. 11 pages.

Related U.S. Patent Documents

(Continued)

Reissue of:

(64) Patent No.: **9,665,013**
Issued: **May 30, 2017**
Appl. No.: **14/135,372**
Filed: **Dec. 19, 2013**

Primary Examiner — Christina Y. Leung
(74) *Attorney, Agent, or Firm* — Finnegan, Henderson, Farabow, Garrett & Dunner, LLP

U.S. Applications:

(62) Division of application No. 12/218,080, filed on Jul. 11, 2008, now Pat. No. 8,705,010.

(Continued)

(57) **ABSTRACT**

The invention relates to a lithography system, for example for projecting an image or an image pattern on to a target (1) such as a wafer, said target being included in said system by means of a target table (2), clamping means being present for clamping said target on said table. Said clamping means comprises a layer of stationary liquid (3), included at such thickness between target and target table that, provided the material of the liquid (C) and of the respective contacting faces (A, B) of the target (1) and target table (2), a pressure drop (P_{cap}) arises.

(51) **Int. Cl.**
G03F 7/20 (2006.01)

(52) **U.S. Cl.**
CPC **G03F 7/70783** (2013.01); **G03F 7/707** (2013.01); **G03F 7/70691** (2013.01); **G03F 7/70875** (2013.01)

24 Claims, 3 Drawing Sheets

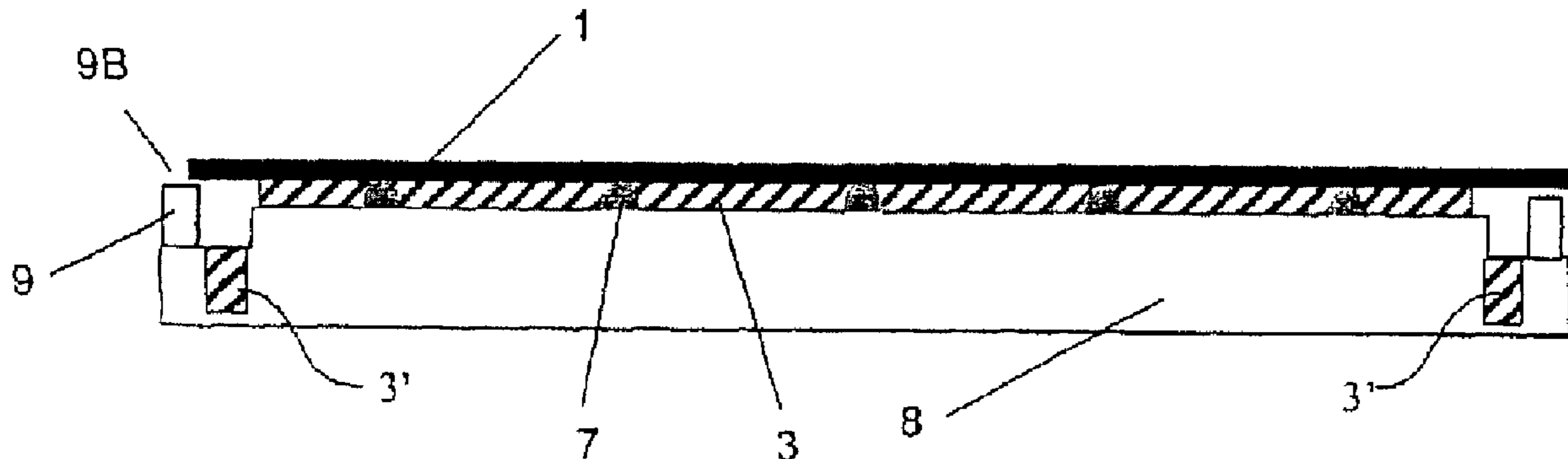

Related U.S. Application Data

(60) Provisional application No. 60/959,531, filed on Jul. 13, 2007.

(56) **References Cited**

U.S. PATENT DOCUMENTS

7,158,211 B2 1/2007 Straaijer
 7,307,696 B2 12/2007 Ottens et al.
 2001/0028456 A1* 10/2001 Nishi G03F 7/70866
 356/400
 2003/0082466 A1 5/2003 del Puerto et al.
 2004/0160582 A1* 8/2004 Lof et al. 355/30
 2004/0227925 A1 11/2004 Sato
 2005/0046813 A1 3/2005 Streefkerk et al.
 2005/0122503 A1 6/2005 Ottens et al.
 2005/0128463 A1 6/2005 Ottens et al.
 2005/0146694 A1 7/2005 Tokita
 2005/0237501 A1* 10/2005 Furukawa G03F 7/70341
 355/30
 2005/0259236 A1 11/2005 Straaijer
 2005/0259238 A1 11/2005 Gao et al.
 2006/0017893 A1 1/2006 Mertens et al.
 2006/0033892 A1 2/2006 Cadee et al.
 2006/0087637 A1* 4/2006 Ottens G03F 7/70783
 355/72
 2006/0132733 A1 6/2006 Modderman
 2006/0139614 A1* 6/2006 Owa et al. 355/72
 2006/0285096 A1 12/2006 Jacobs et al.
 2007/0009649 A1 1/2007 Nakamura et al.
 2007/0177125 A1* 8/2007 Shibazaki G03F 7/70341
 355/72
 2007/0196774 A1* 8/2007 Fujiwara G03F 7/11
 430/322
 2007/0273856 A1* 11/2007 Margeson G03F 7/70716
 355/53
 2008/0043210 A1* 2/2008 Shibuta G03F 7/70866
 355/30
 2008/0106712 A1* 5/2008 Nagasaka G03F 7/70716
 355/30
 2008/0117391 A1 5/2008 Onvlee et al.
 2008/0129969 A1 6/2008 Peng et al.
 2008/0137055 A1* 6/2008 Hennus G03F 7/70875
 355/72
 2008/0202555 A1* 8/2008 Shibazaki G03F 7/70341
 134/6
 2008/0278695 A1 11/2008 Shirata
 2008/0284995 A1 11/2008 Ottens et al.
 2009/0027649 A1 1/2009 De Boer et al.
 2010/0238421 A1* 9/2010 De Jong B82Y 10/00
 355/53
 2010/0265486 A1 10/2010 De Jong et al.

FOREIGN PATENT DOCUMENTS

CN 1614513 A 5/2005
 CN 1614513 A 9/2005
 CN 2726828 9/2005

CN 1684001 A 10/2005
 CN 1723541 A 1/2006
 CN 1839463 A 9/2006
 CN 1873914 12/2006
 DE 2010-533385 A 10/2010
 EP 1304727 4/2003
 EP 1493 838 A1 1/2005
 EP 1586948 A 4/2005
 EP 1586948 A1 4/2005
 EP 1571695 A1 9/2005
 EP 1610182 12/2005
 EP 1280188 1/2007
 EP 1791027 5/2007
 EP 1923743 5/2008
 EP 13 17 9130 9/2013
 EP 13 17 9131 9/2013
 EP 13179130 9/2013
 EP 13179131 9/2013
 JP 61-239624 10/1986
 JP 61239624 10/1986
 JP 05-183042 A 7/1993
 JP 5183042 7/1993
 JP 07-017628 A 1/1995
 JP 7017628 1/1995
 JP 2004-0134538 A 4/2004
 JP 2004119716 4/2004
 JP 2004363160 12/2004
 JP 2005-109489 A 4/2005
 JP 2005-142570 A 6/2005
 JP 2006-310588 9/2006
 JP 2010-533385 A 10/2010
 JP 5372928 9/2013
 JP 2014-030038 A 2/2014
 JP 2014-039048 A 2/2014
 KR 10-2003-0084370 A 11/2003
 KR 10-2004-0102365 A 12/2004
 TW 561522 B 11/2003
 TW 200409700 A 6/2004
 WO 2004/033197 A2 4/2004

OTHER PUBLICATIONS

Tas et al. The Institution of Electrical Engineers, Stevenage, GB, Tas, N.R et al., "Capillarity Induced Negative Pressure of Water Plugs in Nanochannels", XP002502485, Database Accession No (Aug. 19, 2003).
 Taiwanese Search Report with English Language Translation, dated Oct. 22, 2015, Taiwanese Application No. 102129451.
 Office Action for Chinese Publication No. CN103456671 dated Jul. 16, 2015 (16 pages).
 Office Action for Chinese Publication No. CN103456670 dated Jul. 21, 2015 (17 pages).
 Chinese Office Action with English Language Translation, dated Apr. 8, 2016, Chinese Application No. 2013103789804.
 United States Office Action, dated Jun. 14, 2016, U.S. Appl. No. 14/135,378.
 Notice of Allowance in U.S. Appl. No. 14/135,378 mailed Dec. 23, 2016. 11 pages.

* cited by examiner

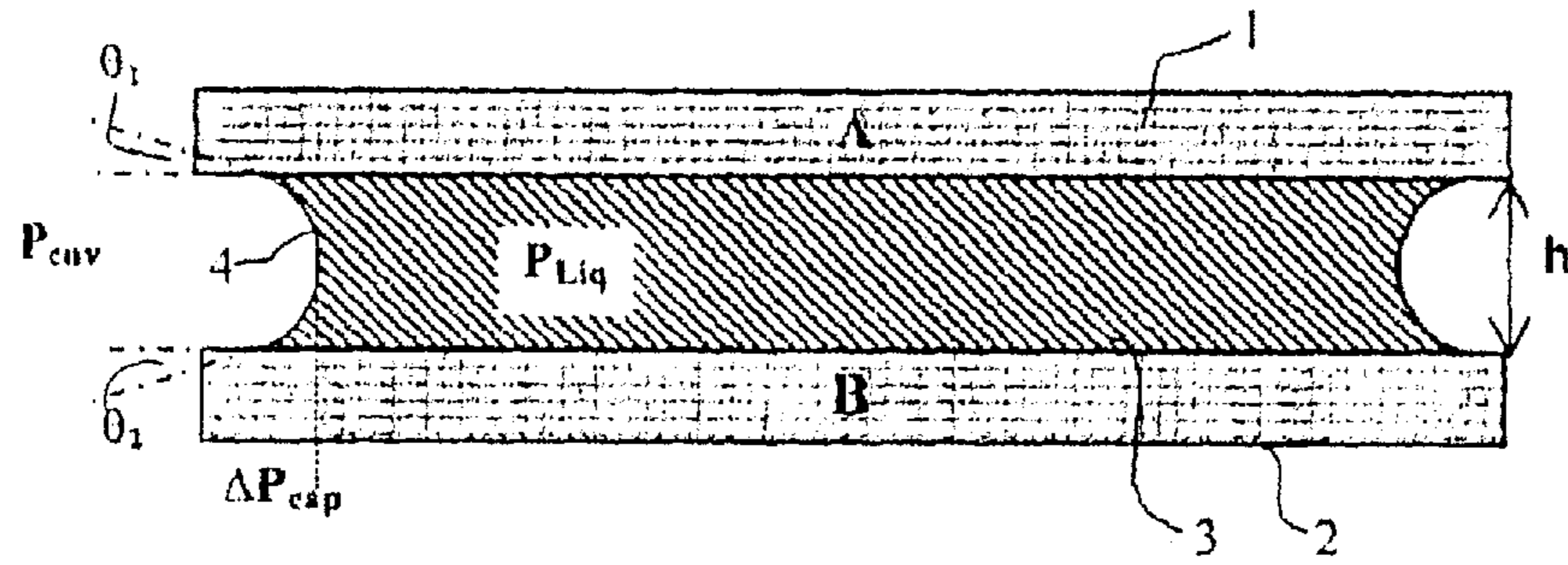

FIG. 1

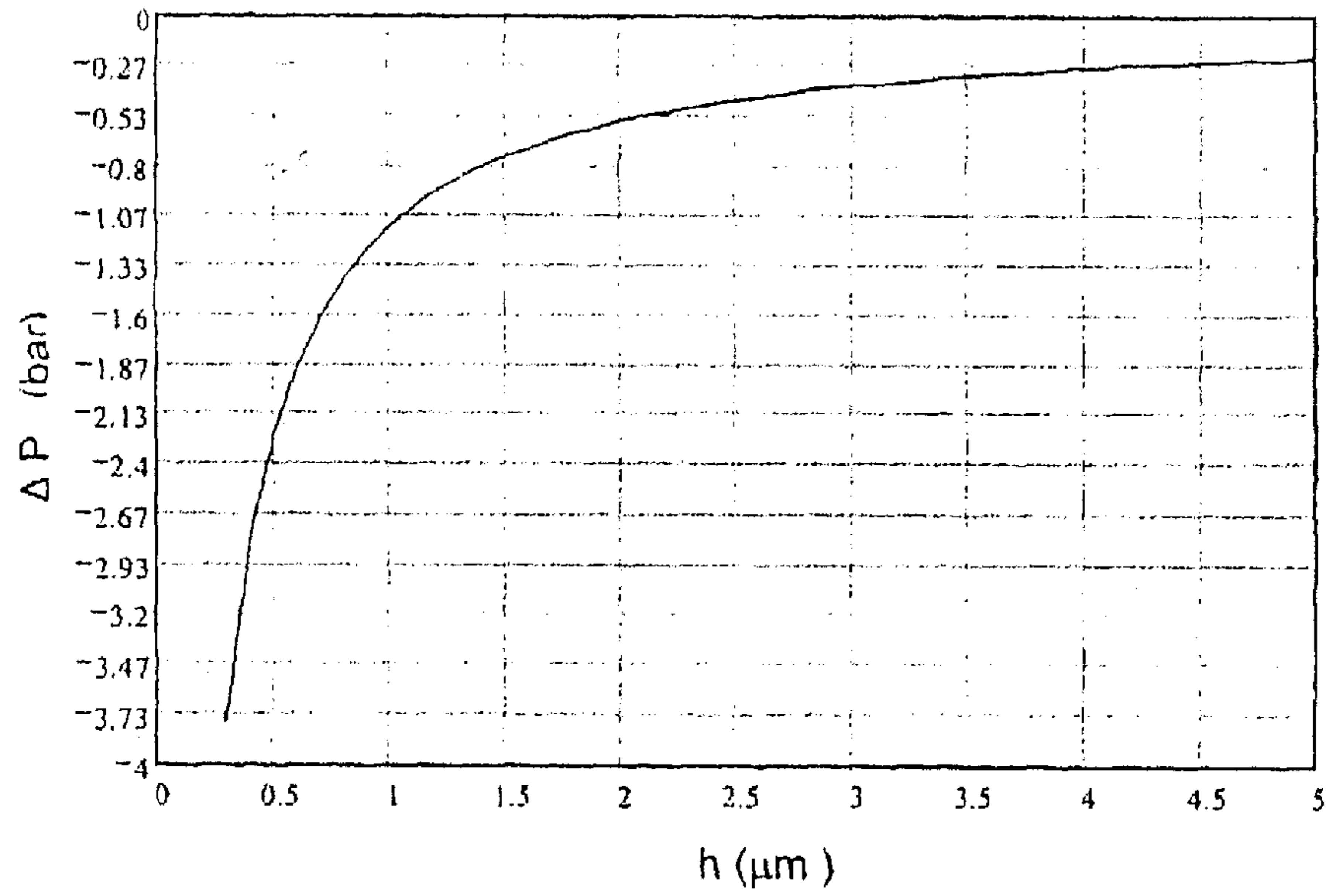

FIG. 2

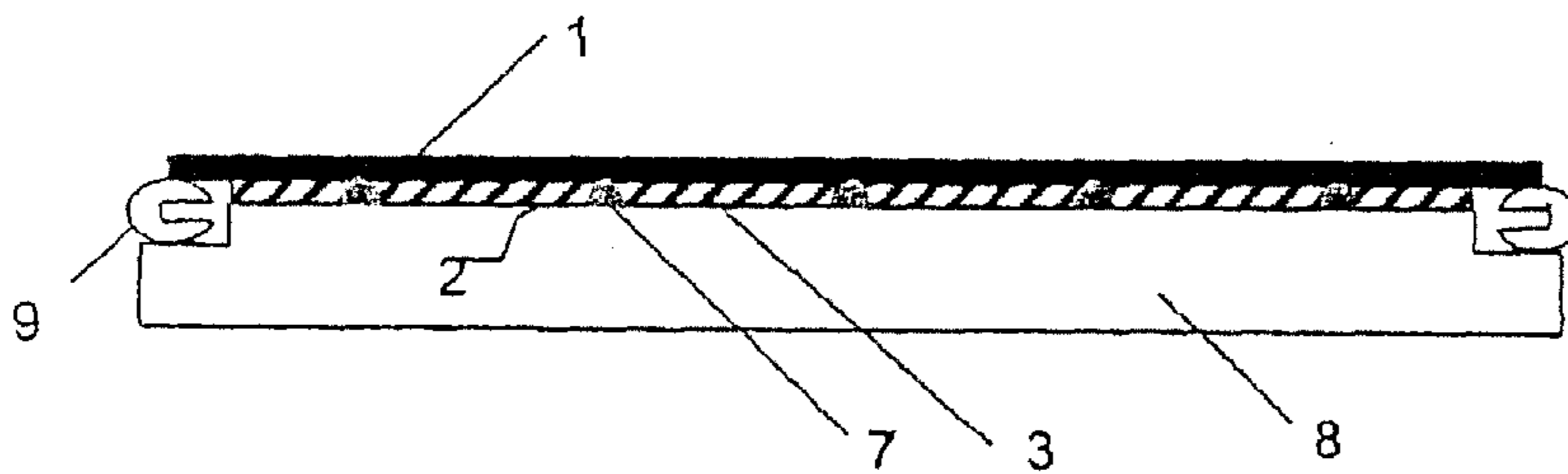

FIG. 3

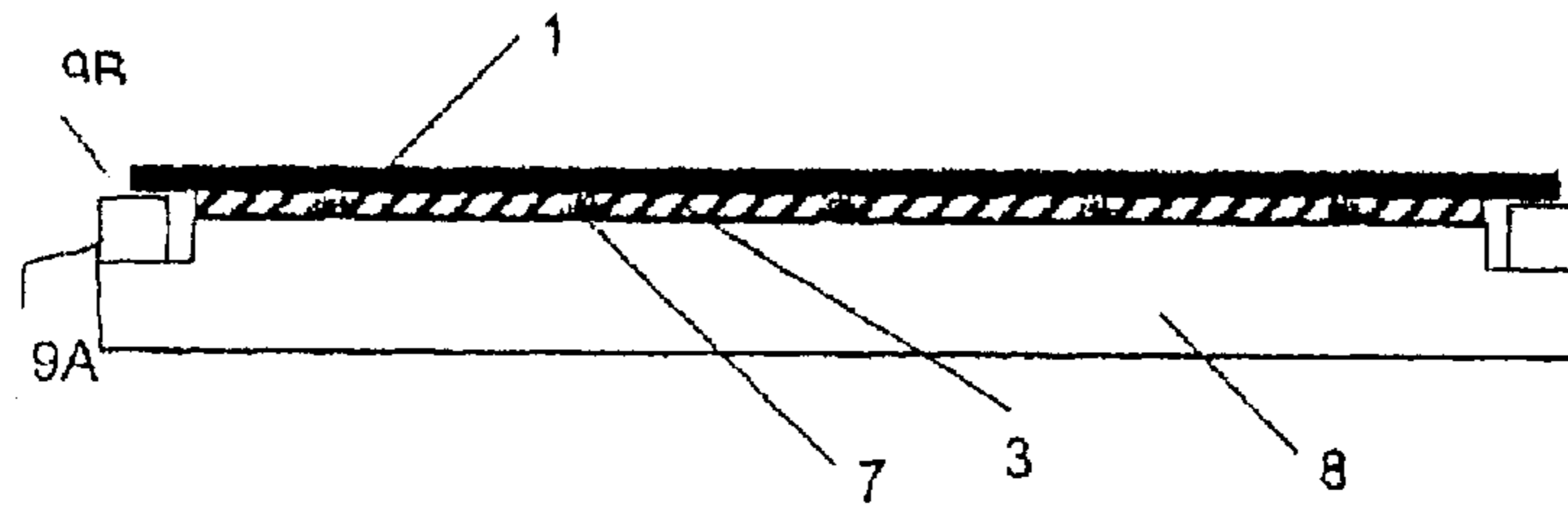

FIG. 4

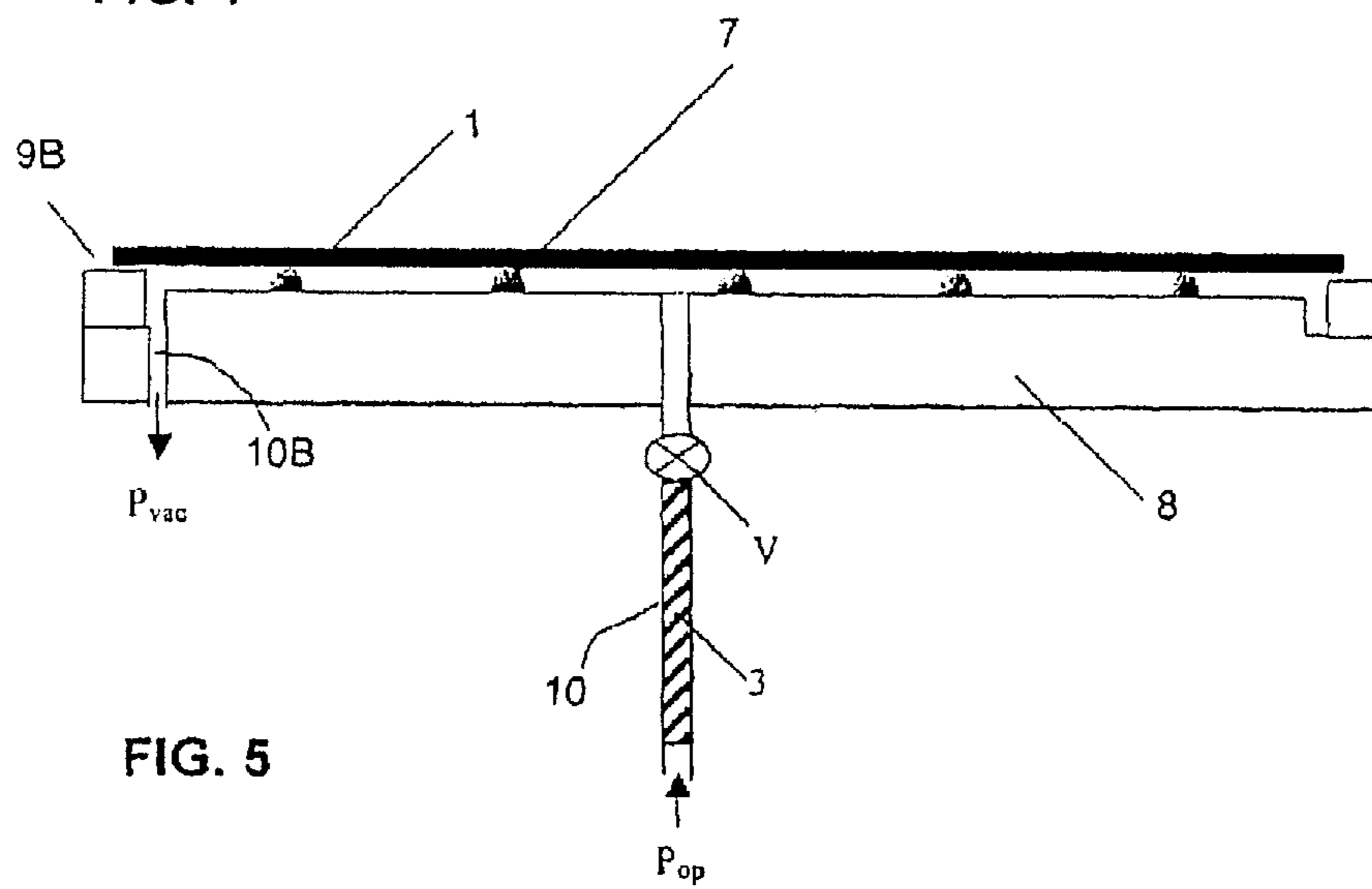

FIG. 5

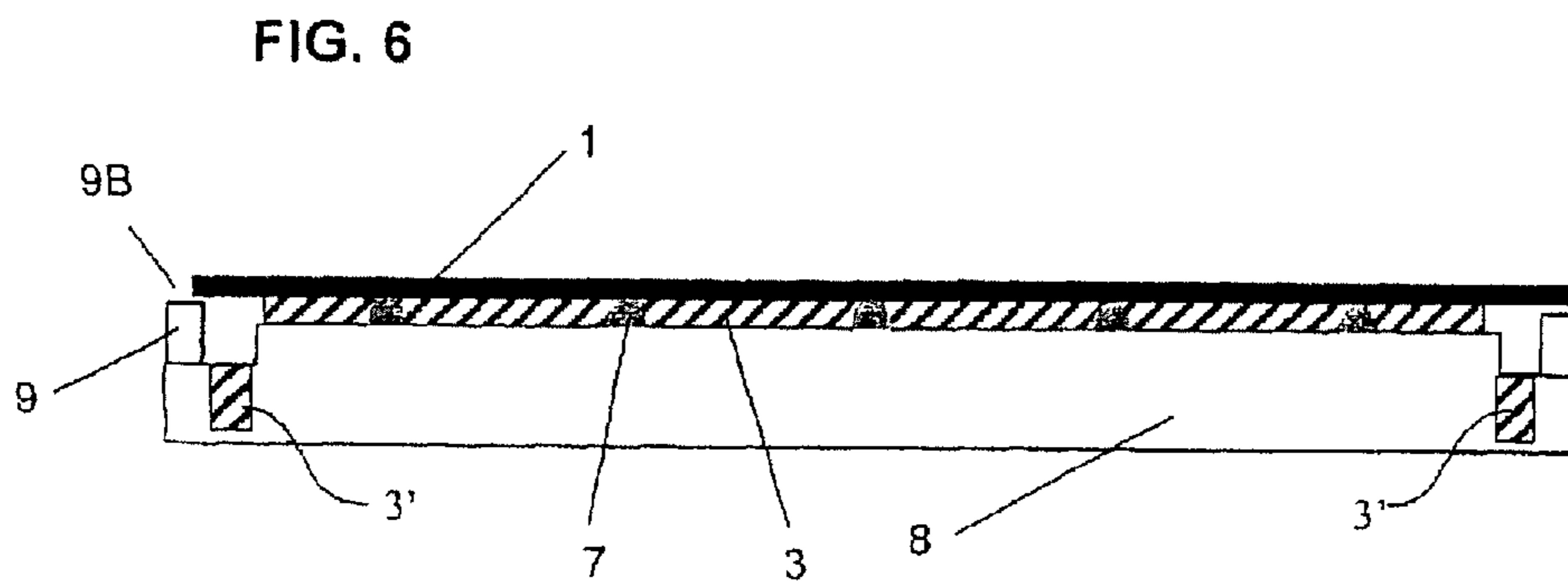

FIG. 6

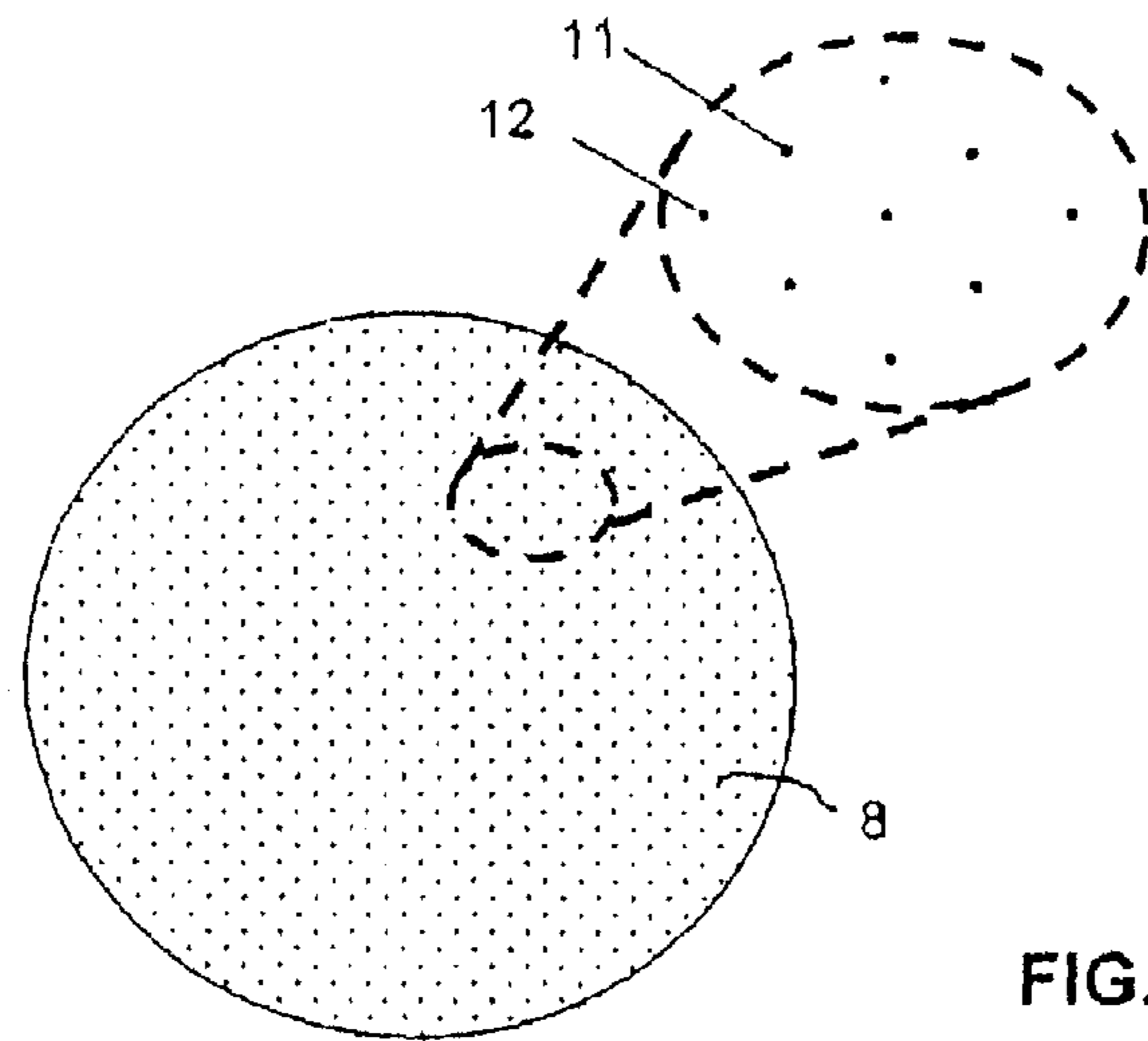

FIG. 7

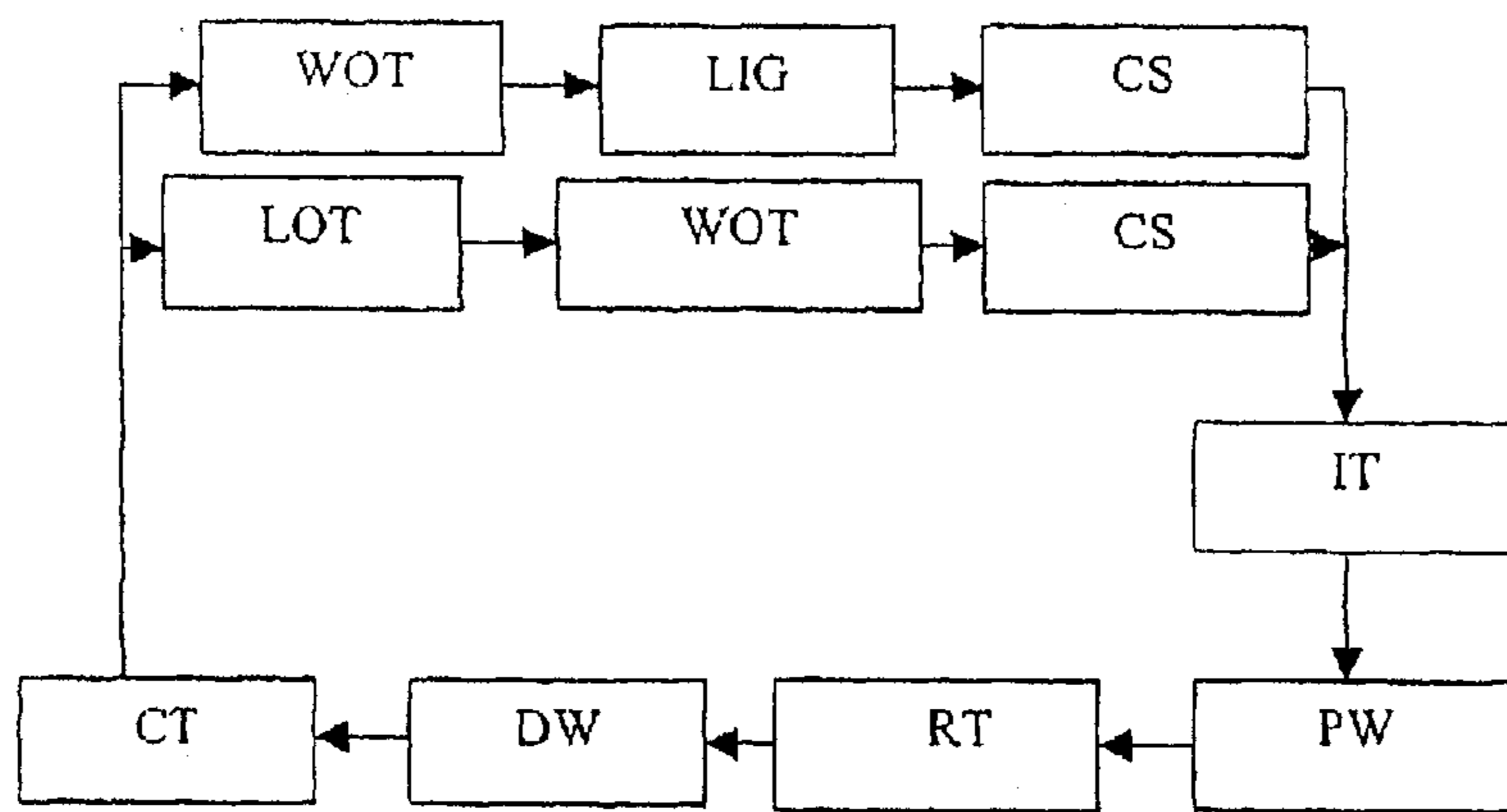

FIG. 8

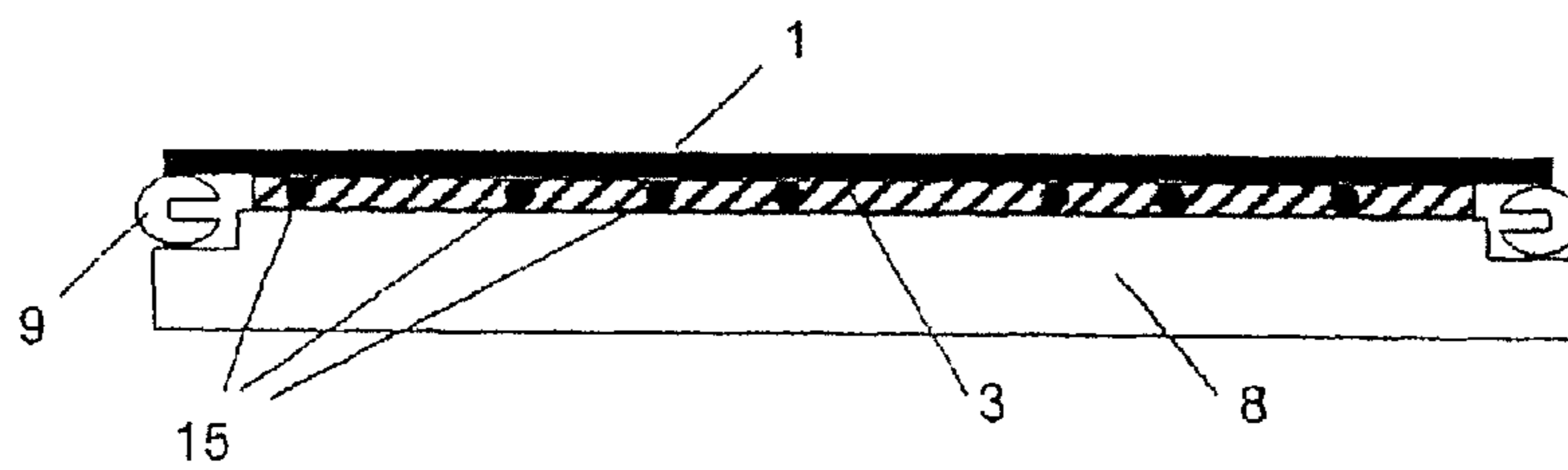

FIG. 9

LITHOGRAPHY SYSTEM, METHOD OF CLAMPING AND WAFER TABLE

Matter enclosed in heavy brackets [] appears in the original patent but forms no part of this reissue specification; matter printed in italics indicates the additions made by reissue; a claim printed with strikethrough indicates that the claim was canceled, disclaimed, or held invalid by a prior post-patent action or proceeding.

[CROSS REFERENCE TO RELATED APPLICATION] CROSS-REFERENCE TO RELATED APPLICATION

[The present patent application is a non-provisional application claiming the priority of a provisional application of Application No. 60/959,133, filed Jul. 13, 2007.] *This is a reissue of U.S. Pat. No. 9,665,013, issued on May 30, 2017, from U.S. patent application Ser. No. 14/135,372, filed Dec. 19, 2013; which claims the benefit of priority from U.S. patent application Ser. No. 12/218,080, filed Jul. 11, 2008, now U.S. Pat. No. 8,705,010, issued Apr. 22, 2014; which claims the benefit of priority from U.S. Patent Application No. 60/959,531, filed Jul. 13, 2007. The entire contents of the above-identified applications are incorporated herein by reference in their entireties.*

FIELD OF THE INVENTION

The present invention relates to a Lithography system for projecting an image pattern on to a target surface such as a wafer.

Such systems are generally known, e.g. from WO 2004038509. In the example presented by the latter system, the target to be patterned is subjected to incidence of photons or charged particles such as ions and electrons. So as to realize high precision patterning of the target, it is to be firmly bonded or connected to a target table by means of which the target is moved relative to the source of incidence, at least if position measurement of said target is performed via said target table. Such movement is performed at least in a direction essentially transversely to a main direction of incidence. It is preferably also to remain in position relative to said table during handling of the target, e.g. during insertion and removal of the target to and from the position where it is to be processed, all be it that relative position of target and table could be measured as a final handling part. Moreover, such requirement should remain valid where insertion and removal is to be performed to and from vacuum environment. Various solutions exist for meeting the above requirements, e.g. by means of electromechanical clamping.

The position where the target, commonly a wafer, is processed in a modern lithography system is a target carrying means, commonly a chuck or a wafer table, here alternatively denoted as a reference to the target. Such reference, i.e. carrying means is shaped ultimately flat so as to support minimization of positioning and/or focus errors during lithographic exposure of the target. To this end, in particular for taking away and/or preventing occurrence of bow and warp therein, the target is at least during exposure maintained in close contact to the reference by the exertion of a force thereon. In this manner the target is also maintained optimally within focus depth of the lithography system in which it is included. Commonly said force is

realized as a pulling force, generated by electrostatic and or vacuum means acting on said target.

Such solutions however, may have the disadvantage of carrying tubes, cables and/or wiring with the table, thereby increasing the complexity of a required, highly refined positioning of said table relative to a projection means of the litho system. The disadvantage is also present in systems where the target is to be taken out and in integrally with the target table give the coupling and decoupling actions which are then to be performed on cabling, wiring and/or conduits.

Still further and important requirements to lithography system for patterning a target include the realization of flatness thereof, i.e. a requirement towards cancellation of wafer bow and warp, which is done by pulling the target to a reference. The means for performing this function are normally the same as or limited to those for performing the function of keeping the target in position on said table within an exposure field.

The means for maintaining said target in position and/or for pulling the same to a flat reference may be loaded by thermal expansion and contraction due to an energy load of a projection system of the system, as included for patterning said wafer.

Thus a further requirement to the known lithography systems is to realize a thermal conduction between target and target table, in practice so as to conduct heat from said target towards a heat dissipating part of the system. Such swift conduction and dissipation of heat limits positioning distortion by thermal expansion or contraction of the target. The latter is in particular important in modern lithography systems where is a quest for realizing high throughput, e.g. in terms of wafers per hour, the target is subjected to relatively high energy loads which normally translate into heat and which may cause said positioning distortion if not addressed.

Where heat dissipation may be addressed by heat dissipating means, the transport of heat induced to said target towards said heat dissipating means may still be a limiting factor in any solution towards heat dissipation. It is therefore a further object of the present invention to realize a method for clamping and a clamping means which optimally addresses the issue of heat conduction while remaining practical in use and while minimally if not totally not distorting a positioning function of the table or chuck carrying said target.

BACKGROUND

In general positioning of targets such as wafers on a chuck is known from machining processes, as in EP 0100648, JP7237066 and JP8064662, where wafers are frozen on to a chuck before machining the same. According to abstract of the latter publication, a wafer is mounted to a wafer mounting face through a pure water layer having micro thickness. A disadvantage in respect of the required positioning precision in case of transfer of these known concepts to a lithography system, is the piping required for feeding refrigerant through the chuck.

The preceding disadvantage is illustrated in PCT/US01/26772, which discloses a wafer clamp in a lithography system. The clamp is also used for transport of heat induced by a charged particle beam on a target. The clamping and releasing of the target is in this device performed by applying "one or more" phase transitions to a clamping component that is applied between a wafer and a supporting structure. These phase transitions "facilitate various operations throughout the process" and "ensure that the wafer

may be easily loaded and released from the structure. The clamping component is applied in a liquid or gaseous form, and brought into a solid state by active cooling of the support structure, so as to achieve a solid clamping of wafer to said structure. It is here concluded that such a manner of clamping can basically be denoted as gluing the wafer.

The above known clamping device for a lithography system is indicated to be “particularly useful in processes that require wafer cooling”, in particular in vacuum due to a large contact area between component and wafer, and a high thermal conductivity of the clamping component. A disadvantage of this known system however, in addition to the required temperature changes in the support structure, is the plurality of conduits required for separately delivering the clamping component and a circulated chilled fluid to the target table.

US patent publication 2005/0186517 relates to a process for a lithography system, of attaching a wafer to a chuck aligning a wafer to a wafer stage and subsequently exposing the wafer. In particular it teaches to cause opposite stress against wafer expansion after an initial stress relieving expansion of a wafer chuck, thereby potentially doubling the amount of allowed heating of the wafer before undesired slip between wafer and chuck occurs. The attaching process is exemplified by a process using electrostatic clamping and by a process of using vacuum clamping, also requiring cabling and or conduits to a moveable table carrying said target.

Outside the vacuum environment encountered in the field of lithographic exposure of targets, it is from the technical area of wafer testing, known by EP patent application 511928 of 1991 en by presentation publication “Liquid interface at wafer test” presented at the SWTW 2005 conference on Jun. 4, 2005, known to integrate heat conduction and clamping of a wafer to a chuck by means of a flowing film of water. The principle conceived in this known device is to realise conduction of target induced heat through the film of water by maintaining the same at ultimately small thickness, however sufficiently large for levelling out roughness as typically encountered at wafer back-sides. Clamping is in this principle according to the first document realised by fluid transfer on the top side of a grooved, planar clamping section of a chuck. The later document, where the grooves seem to have been omitted from the clamping section, implicitly confirms this explanation by noting that heat is not carried away by fluid flow: “it is conducted through the fluid into the chuck”. Moreover it indicates that a wafer is tightly pulled onto the film by means of a vacuum, which vacuum is applied to a liquid film between chuck and wafer, at recovery locations in the chuck, peripheral to a wafer positioned on the chuck, the fluid thereby entering via a central opening.

It is impractical to carry over this concept known from the field of wafer testing to the field of wafer exposure, due to the vacuum circumstances at which lithographic exposure is performed in modern systems. However also for lithographic systems not performing under severe vacuum conditions, a disadvantage exists in that said flowing of water may be an undesired phenomenon in general, and in particular due to a risk of water leads becoming clogged by contaminations. In case of a required vacuum operation the known system fails due to a lack of over pressure at the top side of the target. Where the recovery openings require some amount of vacuum, or pressure below atmospheric for creating the flow of liquid, the central supply opening for the fluid pre-supposes a pressure higher than that at the recovery side. Should this system be entered into a vacuum environ-

ment, the target will tend to be lifted from its position rather than that it will tend to be clamped.

SUMMARY OF THE INVENTION

The present invention now, seeks to realise a clamping system for contemporary lithography systems, i.e. with highly refined pixel resolutions and highly refined accurately at relative positioning of target and source. Constraints herewith encompass a vacuum operable system and optimal heat conduction from an exposed target to a target carrying means or chuck. In realising such, the invention proposes to use a stationary liquid film, capillary included between said carrying means and said target for performing both said heat conduction function and a clamping function by the same liquid means.

With the novel solution cables or conduits and the like leading from “fixed” world to a moveable target carrying means are entirely obviated, thereby considerably if not totally reducing negative effect thereof on positioning accuracy of the carrying means.

The present invention surprisingly departs from an idea that strong pulling forces may be exerted to liquids like water if the conditions thereto are set properly, as is in very general wording set out in the article “The Physics of negative pressure”, published by Discover on Mar. 27, 2003. It was conceived that in the case of lithography systems, such settings could be reached if a liquid was maintained stationary in capillary manner between the surfaces of a target of wafer and a target carrying means or chuck, which surfaces are for obvious reasons normally maintained as flat as possible.

At such capillary inclusion of liquid, in fact a liquid volume between two plates or plate like structures as in the present lithography application, adhesion of the liquid to the surfaces of the plates causes a circumferentially extending liquid surface, concavely extending between said two plates. This concave liquid surface tends to maintain its shape, even if tension is applied by pulling the plates apart, implying that negative tension occurs with the capillary included liquid volume.

It was further realised by the invention that with said capillary inclusion, the liquid layer is of such small magnitude that boiling of the liquid, e.g. water, can not occur, even when the liquid is at negative pressure. This phenomenon is also of practical value at heat conduction. Thus it was conceived that a liquid at negative pressure may be applied for providing the force required for pulling a target or wafer to a flat reference. In other words, a liquid in a small gap, as between plates formed by said reference and said target, exerts a force on the plates constructing the gap. This force, which apart from the height of the gap depends on the material properties of liquid and plates, is applied for realising the force for maintaining a target and a target table integral.

Although in such novel concept the pressure inside the fluid is below zero, implying that there is tension in the liquid, it was realised that the liquid will not cavitate, i.e. will not boil, when the height of the gap between target and reference is made smaller than the critical radius of a vapour bubble at accompanying liquid pressure. It was thus realised that also in this respect, the impossibility of a liquid like water to boil when in the described stationary capillary inclusion, a liquid may generate a considerable clamping force, sufficient for lithographic application.

It may be evident that the presently invented principle may be set into practice in various manners.

BRIEF DESCRIPTION OF THE DRAWINGS

The invention will be further elucidated by way of example in the following embodiment of a mask-less lithography system according to the current invention, in which:

FIG. 1 in sectional view schematically illustrates a liquid, capillary included between two plate like structures, i.e. surfaces of materials A and B;

FIG. 2 is a graphical illustration of the relation of capillary pressure drop for a fused silica optical flat and a silicon wafer, with gap height between such plates capillary including water;

FIGS. 3 and 4, are schematic illustrations of implementations of the idea underlying the present invention;

FIG. 5 is a schematic illustration of a first manner of introducing liquid in the capillary gap between table and target;

FIG. 6 by the provision of a circumferential gutter schematically illustrates a measure for minimising evaporation of liquid from the capillary gap;

FIG. 7 is a figurative illustration of a manner of realising a liquid layer between target and target table;

FIG. 8 is a process flow for a lithographic system, at least part thereof according to the present invention; and

FIG. 9 is a schematic illustration of the use of spacers.

In the figures, corresponding structural features, i.e. at least functionally, are referred to by identical reference numbers.

DETAILED DESCRIPTION OF THE INVENTION

FIG. 1 shows a lithography target, here in the form of a wafer 1, which normally moves relative to e.g. a charged particle beam column of a litho apparatus, or other kind of beam source for lithography, by means of an actuated target table or chuck, not indicated in this drawing. Between a top side of such target table 2 and said target 1, a volume of liquid 3 is included capillary. To this end the target 1 and top surface 2 have a mutual nominal distance of gap height h. The volume of liquid, according to the invention preferably water, is such that the radius of the target, as taken in top view, is virtually met by a radius R of the capillary included liquid 3. In any case, the radius of an incircle of the target is at least met by the radius of an excircle fitting the volume of liquid within the boundary of the target. In fact, the liquid is to remain, preferably only with a small distance thereto, within the boundaries of the target. The thus included liquid 3 forms a liquid surface 4, alternatively denoted fluid interface 4 at its outer periphery which, as taken in the section according to FIG. 1, is generally concavely shaped, due to adhesive connection of the liquid to the target 1 and the top side 2 of a target table respectively. This concave surface 4 tends to maintain its shape at pulling the target and target table apart, and depends on pressure differential. The concaveness of the interface 4 depends on respective contact angles θ_1 and θ_2 , which in turn depend on the material of table 2, and target 1, in this case material A and material B respectively.

In FIG. 1, the capillary pressure ΔP_{cap} is the pressure drop over the fluid interface 4 at the edge of the volume of liquid 3. The capillary pressure may according to yet further insight underlying the invention defined by a simplified equation:

$$\Delta P_{capillary} = \frac{-\gamma_{liquid}(\cos(\theta_1) + \cos(\theta_2))}{h} \quad (1)$$

In which γ_{liquid} is the surface tension of the Liquid in [N/m] and in which the contact angles θ_1 and θ_2 are the angles at which the liquid/vapor interface 4 meets the materials A and B respectively. The contact angle is amongst others, however significantly if not predominantly determined by material properties of the liquid 3 and the solid material A and B at the location of interface 4. In the same respect also the following equations holds:

$$P_{env} + \Delta P_{cap} = P_{liq} \quad (2)$$

With

P_{env} = environmental pressure

ΔP_{cap} = capillary pressure at interface 4

P_{liquid} = pressure in liquid 3

Combining equations (1) and (2) it may be seen that

20

$$\text{If } -\Delta P_{cap} > P_{env}, \text{ then } P_{liquid} < 0 \text{ bar} \quad (3)$$

The latter situation arises when P_{env} approximates 0 bar, or under atmospheric pressure when $|\Delta P_{cap}| \geq 1$ bar. Because $P_{liq} < 0$ bar this means that the pressure inside the liquid is negative. It is further recognised that in case P_{liq} is smaller than the vapor pressure of the liquid, then fluid 3 might start to boil or cavitate. Boiling of fluid 3 is however prevented by making the height of the gap smaller than a critical radius of the bubbles.

30

FIG. 2 illustrates the capillary pressure drop, which is taken as indicative for an amount of force that can be exerted, at pulling apart the plates having included a fluid, in casu water, as described above. The depicted curve is derived from a calculation involving two plates, i.e. contacting faces and water, one being a silicon wafer, and the other a fused silica optical flat. The validity of the curve has been tested on the basis of calculations and measurements involving glass plates instead of SiO₂. The present curve, which compares to that of glass and water, indicates that sufficient pulling power can be developed at gap heights as of nominally 10 μm and below, which, even at nominal heights of 5 μm is well in reach of regular lithographic applications. A particularly interesting range exists below a gap height of around 1 μm and below, since at this gap height the pressure drop is more than 1 bar, implying that negative pressure in the gap liquid already occurs at atmospheric pressure. However, already the pressure drop of near 0.2 bar, occurring at gap height of 10 μm is sufficient for such clamping that safe handling of a wafer table with placed wafer, e.g. at insertion into vacuum, is guaranteed.

50

FIG. 3 illustrates a practical elaboration on the invented principle and schematically shows part of a lithographic system, including a target 1 embodied by a wafer, a top side 2 of a wafer table 8 or chuck part, a liquid 3 in the form of water, and so called viton or rubber O-rings 9. The O-rings 9 seal off liquid vapour evaporating from the gap containing liquid 3 by being inserted in a rim part of reduced height of the wafer table 8. By this measure the top side of the O-ring is set to a level corresponding in height to that of, and preferably being slightly higher than that of burrs 7 on the top side of wafer table 8. Being provided with an incision at a radial side, in this example the radial inward turned side, the O-ring may be compressed between table and wafer without undue force requirement, however sufficient for preventing leakage of vapour, which is especially an issue in the vacuum environment in which such lithography means may be applied. In fact the O-ring, which is here of a

60

65

thickness in the range from 0 to 5 mm diameter, thus form a C-ring, implying that the pressure required for compressing the O-ring is kept minimal. Some radial distance is kept between the O-ring and the central, raised table part of the target carrying means **8**, so as to allow for openings, not depicted here, such as recovery openings for the fluid **3** applied in between. Preferably an O-ring or kind-like elastically deformable means is applied circumferentially around the target. In this manner larger forces may be applied between target and elastically deformable means, which allows the use of elastically deformable means with higher roughness, which is easier to get hands on, and relatively economic at purchase.

Alternatively, as in FIG. 4, leakage of vapour is prevented by a vapour limiting ring **9A**, supported by an outer rim of the table, largely closing off the circumferential opening of the liquid gap, by leaving a very small vertical distance **9B** between ring **9A**, and target **1**, supported by an outer rim of the table. In particular this may be 10 to 20 times smaller than the gap height between target and target table.

Further to the set up according to the present invention, use is made of the principle that liquid at a pressure below its vapour pressure is or can be in a metastable state. Notice is taken that there is a critical radius for cavities beyond which such cavities grow unlimited. When now the smallest dimension of the liquid containing volume, as in accordance with preferred embodiment of the invention, is made very small in relative to, or even smaller than this critical radius, cavitation will not occur. When the pressure drop is from the Laplace-pressure, the critical radius is approximately twice the gap height or more. The height depends on the material properties between liquid and solid surface (contact angle).

The invention may further encompass the presence of one or more openings that can be closed for entry of fluid, which may be gas, and opened for release of fluid in said wafer table, thereby enabling release of a target from the table. A volumetrically highly precise fluid entry tube is provided preferably centrally. The invention may also include a pressing means for initially pressing the target into firm contact with said target table, i.e. with a multiplicity of burls **7** thereon. One embodiment for such pressing means involves a high pressure directed perpendicular towards the top side of the target **1**, thereby eliminating any bow of the target and allowing the capillary action to be installed. One favourable manner of realising such pressure in accordance with a further aspect of the present invention is to direct a stream of fluidal means such as wind and water on to said target.

FIG. 5 illustrates a preferred manner of operation in which initial clamping alternatively denoted chucking, i.e. removing bow in the target is removed and in which liquid is introduced between target and table in a more or less combined manner. To this end a central entry channel **10** is provided in said target table, provided with a valve **V**. The wafer is chucked to the wafer table by a vacuum force generated by a vacuum pressure P_{vac} , applied via a plurality of circumferentially present openings **10B**. When the wafer is correctly chucked to the wafer table the valve **V** is opened and the liquid will be sucked into the gap between the wafer and the wafer table. The filling speed of the water that flows into the gap is determined by the sum of the capillary pressure P_{cap} and the pressure difference between the prevailing vacuum pressure P_{vac} and an overpressure P_{op} , and present or applied at the entry of channel **10**, i.e. at a non-illustrated fluid source. Overpressure P_{op} is defined to be higher than the pressure P_{env} prevailing over the target. It is for practical reasons limited to 1 bar, so as not to disturb

the position of the target on the table, and the effective liquid pressure P_{liq} is calculated with.

FIG. 6 illustrates a manner of preventing, at least further minimising evaporation of liquid from the capillary gap, i.e. from between target and target table. Circumferentially to the target, in the target table, and within the area sealed by elastic deformable means **9**, or minimal gap **9B**, a gutter of significantly larger width than the capillary gap height is made for containing non capillary included liquid **3'**. Preferably the fluid **3'** is of the same type as the capillary included fluid **3**. It is however provided with a significantly larger surface or interface area. Although this gutter could be filled using the liquid source with pressure P_{op} , for channel **10**, be it via a separate lead and valve, preferably separate filling means are provided, i.e. independent from the supply of capillary included fluid. The filling means may be any independent filling means, e.g. including a separate liquid source, dedicated leads and valve towards said gutter, and/or a fluid pump.

FIG. 7 figuratively illustrates an alternative manner of introducing said capillary layer. Rather than entering fluid via a central opening as in the first embodiment example, the fluid is here entered to either one or both surfaces of table and target by depositing droplets **11**, e.g. by spraying. Preferably however the deposition in a controlled manner so as to achieve evenly distributed liquid parts, e.g. by placing droplets by means of a droplet dispensing means, for example having one or more droplet dispensing mouths at predefined locations. In these manners of deposition a swift distribution of liquid is achieved, enhancing the practicability of the present new clamping method and means therefore. In the present example droplets are deposited on the target table **8**. In this embodiment various openings **12** for prevention of air inclusion are distributed in a pre-defined manner, preferably generally evenly distributed, over the area of the target table.

Apart from above said openings, the surface of the target table is defined by the presence of burls **7**, which burls are for the sake of withstanding the clamping force of the capillary liquid included with an increased density of distribution. In this manner an attracted target may remain flat, i.e. will not bow between the burls under the force of the capillary fluid.

As a specific measure, one or both of the contacting surfaces of target and table may be surface treated, or coated with a material for influencing a contacting angle between the liquid and the relevant contacting surface, in particular towards a desired clamping pressure, more in particular at operating conditions, i.e. in vacuum. In practice, given a current standard for targets in case of wafers, only the target table will be coated. So as to still influence the capillary pressure drop in the clamp according to the present invention, it is conceived to adapt the burl height to a specific, desired pressure drop, given the conditions of liquid material, target and target table contacting face material. Such adaptation may for instance be made to meet a minimum desired clamping force and to adapt to a specific combination of clamping force and distribution or mutual distance of burls, in particular to prevent local bow of the target between the burls, given a clamping pressure and resulting force on the target. A minimum burl height is hereby taken into account, while it is also considered that burl density may be adapted, for instance it may be increased to meet a minimum required clamping force. Said minimum burl height is considered in respect of a measure to accommodate dust or other contaminating particles between the burls and within the gap height. the latter of course within the constraint of a measure

according to the invention of maintaining the gap height to such minimum that boiling of the fluid in between cannot occur.

FIG. 8 illustrates a relevant part of a process flow for a lithographic apparatus or system improved with the present invention, where the target is formed by a wafer. The process part departs from the action and status of clean wafer table CT, indicated in the lower left corner. From there two alternative process paths may be followed. The first and above illustrated path part is characterised by first step WOT of placing a wafer on the target table, second step LIG of liquid flow into the gap between table and wafer through conduits in the table, and third step CS of sealing the conduits for water, i.e. liquid supply and air inclusion removal. The second possibility of implementing a process in accordance with the invention is indicated by the lower branch, showing the steps of first applying liquid on the table LOT, placing a wafer on the table WOT, and conduit sealing CS, which in this case merely encompasses sealing the air inclusion discharge. Such sealing is preferably performed in a central discharge or supply conduit which is linked to the table surface via multiple branches.

In a subsequent step IT the table and wafer are inserted in a part of the litho system which is to be brought to vacuum, the wafer is processed in step PW, table and wafer are removed from the apparatus in step RT, the water is detached from the table in step DW amongst others by removing or opening any conduit seal, and the wafer table is cleaned.

In case of liquid application LIG, water is applied by at least one, but alternatively also a multitude of water conduits through which the water is supplied to the gap. In accordance with a further aspect of this invention, filling of the gap is performed by relying on a sufficiently large capillary pressure for allowing water, or any other relevant liquid, to pull itself into the gap. In a further embodiment this process is improved, i.e. made faster by using external pressure to increase the pressure during filling. In yet a further elaboration of the invention, also the air inclusion openings are used to supply a lower pressure.

In case of water application LOT on table, application of water is performed by applying small evenly distributed droplets on the surface of the wafer table or wafer. When the wafer is placed on the wafer table the droplets will spread due to capillary action. This process can be aided by suction through opening holes. In case of sealing conduits CS, all holes that are used for filling of the gap have to be sealed after application of the liquid so as to prevent evaporation when the combination of wafer table and wafer are in vacuum. In case of detaching a wafer from the table in process step DW, the openings that are used to supply water and/or prevent air inclusions are also used to apply air pressure and, in yet a further elaboration of the invention the wafer is blown off from the table. The air pressure is in this case applied at least fairly evenly distributed so that the wafer will not brake.

It is also considered that the smaller the gap, the larger the pressure drop that is required to keep flowing speed equal. Such increase in required pressure drop is more than the pressure increase from the capillary pressure available from smaller gaps. Therefore flow by capillary pressure is slower for smaller gaps, in fact gaps beyond a critical gap height given certain conditions including liquid material and contacting face material. At very small gaps an electro-viscous effect increases the apparent viscosity of water, as may per se be known from 'capillary filling speeds of water in nano channels'. Burls are required to reduce the influence of contamination by particles on the backside of the wafer. The

maximum pitch of the burls is determined by deflection of the wafer in between the burls caused by the capillary pressure. A typical value for the pitch of the burls is 3 [mm]. The height of the burl determines the gap, and is in accordance with the invention used for regulating clamping pressure given other system conditions such as materials and dimensions and vice versa. The surface per burl is made sufficient so as not to deform or brake under capillary pressure. The diameter per burl is approximately 25 μm or more. It is preferred that burls are shaped generally rounded, i.e. without edges, to reduce the possibility of particulate contamination during cleaning. These are particles from a tissue during wiping of the table.

In addition to or in stead of using burls 7, spacers 15 (glass grains, SiO₂ grains, etc.) are dispersed uniformly over the carrying means 8 as shown in FIG. 9, for example by being sprayed from over the carrying means 8 or by applying a dispersed solution of the spacers 15, thus providing spacers 15. In an embodiment, the spacers 15 are dispersed in the liquid 3 which ultimately forms the layer of stationary liquid.

Apart from the concepts and all pertaining details as described in the preceding, the invention relates to all features as defined in the following set of claims as well as to all details as may directly and unambiguously be derived by one skilled in the attached figures. In the following set of claims, rather than fixating the meaning of a preceding term, any reference numbers corresponding to structures in the figures are for reason of support at reading the claim, included solely for indicating an exemplary meaning of a preceding term and are thus included between brackets.

A lithography system, for example for projecting an image or an image pattern on to a target (1) such as a wafer, said target being included in said system by means of a target table (2), clamping means being present for clamping said target on said table, wherein said clamping means comprises a layer of stationary liquid (3), included at such thickness between target and target table that, provided the material of the liquid (C) and of the respective contacting faces (A, B) of the target (1) and target table (2), a pressure drop (P_{cap}) arises.

In an embodiment, the pressure drop results in a pressure (P_{liq}) in said volume of Liquid, which is below its vapour pressure.

In an embodiment, the pressure drop is realized in vacuum.

In an embodiment, a pressure (P_{env}) arises, which is significantly lower than an actual environmental pressure (P_{env}) for said layer (3).

In an embodiment, the inclusion is arranged such that said lower pressure (P_{liq}) realizes a negative pressure at vacuum condition, in particular at typical lithographic vacuum condition.

In an embodiment, the wafer table is provided with spacers (7, 15) for defining the thickness of the layer of stationary liquid (3).

In an embodiment, the wafer table is provided with burls, and the liquid (3) is maintained at a capillary condition (P_{cap}) by means of a predefined burl height, i.e., gap height between target table and target, maintained at such minimal level that given the clamping conditions, the liquid (3) is prevented from a possibility to boil, i.e., from a possibility to cavitate.

In an embodiment, the capillary condition is realized by so maintaining a nominal mutual distance of between 0, 1 and 10 μm between target (1) and target table (8).

11

In an embodiment, the circumferential sealing means such as O-rings are included, in particular for preventing liquid from vaporization.

In an embodiment, the sealing means is composed as an elastically deformable means, in particular having a generally C-shaped form as taken in cross section.

In an embodiment, the O-ring or sort means is included circumferentially around said target.

In an embodiment, the sealing means is composed of an O-ring provided with circumferentially extending, slotted cut out, open to a radial side of the ring, in particular to the radial inner side, and extending over a substantial part of the diameter of the ring, in particular up to around the center of the O-ring.

In an embodiment, the circumferential sealing means is composed as a circumferential air gap (9B) between target table (8) and target of a height equal or smaller than the height realized for maintaining said capillary condition.

In an embodiment, the wafer table is provided with a gutter for containing fluid, the gutter being of a width significantly larger than the height of the gap, and located circumferential to a target carrying part of the target table, within the circumference defined by said sealing means for sealing said capillary included liquid between said target and said target table.

In an embodiment, the table is provided with closeable discharge openings, in particular for release of air, at least gaseous material at entry of capillary liquid, in particular centrally closable.

In an embodiment, the openings are included in a recessed circumferential rim of said table, preferably circumferentially to a wafer carrying part of said wafer table, i.e., comprising chucks, in particular within the circumference defined by said sealing means.

In an embodiment, the discharge openings are included generally evenly spread over the surface of said table.

In an embodiment, the clamping liquid is composed of water.

In an embodiment, the table is provided with at least one preferably centrally closeable entry opening, in particular for entry of capillary liquid.

In an embodiment, entry of fluid is realized by spread application of liquid on to either one contact face of table and target.

In an embodiment, the liquid is deposited in a controlled manner by means of a liquid depositing means releasing controlled volumes of liquid drops or lines on the table surface.

In an embodiment, liquid is deposited by a precise depositing means comprising a plurality of depositing mouths.

In an embodiment, the density of burls on the contacting face of said table is determined by a nominal pitch value within the range of 1 to 3 mm.

In an embodiment, at least one of either mutual contacting face of target and table is provided with a coating of different material than of said face base.

In an embodiment, initial pressure means are provided for realizing an initial firm contact between target and table.

In an embodiment, an initial pressure means is realized by means of one or more e.g., centrally provided openings comprising a valve in a supply channel connected to such opening, either in a channel central to all such openings or in each separate channel, which valve is closed in advance of providing fluid to the gap between target and target table, and which gap is exposed to vacuum pressure via further openings, circumferential to a wafer carrying part of said wafer table.

12

In an embodiment, initial pressure means comprises a pump such as a water pump and an air pump or blower, in particular for realizing a first contact between target and table by urging a stream of flowing material on to said target, in particular one of air and water.

In an embodiment, the target table is adapted for loose inclusion, i.e., without connection of conduits in a lithographic apparatus for treating a target carried by the table.

In an embodiment, a wafer table for insertion into a vacuum environment, such as in a lithographic apparatus, is provided with clamping means adapted to the use of a stationary layer of liquid, for clamping a target such as a wafer.

In an embodiment, the clamping are adapted to realize said clamping outside the vacuum space of a lithographic apparatus, in particular before insertion thereof into the vacuum compartment of a lithographic apparatus for treating a target carried by said target table.

In an embodiment, clamping an object having a generally flat contacting face to another object also having a generally flat contacting face is provided, wherein for the purpose of mutual clamping of said objects a layer of stationary held liquid is maintained capillary between said faces.

In an embodiment, the objects are part of a vacuum operable lithographic system.

In an embodiment, the two objects are pressed to one another, in particular by an air stream, in order to allow installment of said capillary inclusion as a clamping means.

In an embodiment, the wafer table is taken out of the lithography system for replacing a target thereon.

In an embodiment, a wafer table in a lithographic apparatus is exchanged with another one for the purpose of exchanging a target in said lithographic apparatus.

In an embodiment, the target table is treated outside a lithographic apparatus, in which treatment the temperature thereof is conditioned.

The invention claimed is:

1. Wafer table (8) for supporting a wafer (1) during processing of said wafer in a lithography system, said wafer table (8) having a top side (2) provided with burls (7) for supporting said wafer (1), wherein said burls have a height above said top side, said wafer table (8) comprising a circumferential gutter located circumferential and directly adjacent to a wafer carrying part (2) of the wafer table, said gutter having a width larger than the height of said burls (7), wherein an outer rim of said wafer table comprises a ring having a fixed position on said outer rim and which is arranged for leaving a very small vertical distance (9B) to said wafer (1) when said wafer (1) is supported by the burls (7),

wherein said gutter is arranged below a plane defined by said top side in a manner that liquid is flowable in said gutter from said top side, and wherein said ring is arranged circumferential to said gutter, wherein the gutter is arranged on the inside of the ring, and said ring extends at least partially above said plane,

wherein said wafer table is adapted for being moved into and out of the lithography system while the wafer is clamped to the wafer table by means of a stationary layer of liquid which is spaced apart from the gutter and arranged in a gap between the top side of the wafer table and a bottom side of the wafer.

2. Wafer table according to claim 1, wherein said burls (7) have a height for maintaining a nominal mutual distance of between [0, 1] 0.1 and 10 μm between said wafer (1) and said top side (2) of said wafer table (8).

13

3. Wafer table according to claim 1 or claim 2, wherein said ring largely closes off a circumferential gap (9B) between said wafer table (8) and [a] the wafer [(8)] (1) supported by said burls (7).

4. Wafer table according to claim 1, wherein said very small vertical distance (9B) is 10 to 20 times smaller than the height of said burls.

5. Wafer table according to claim 1, wherein said wafer table (8) is provided with a plurality of circumferentially present openings (10B).

6. Wafer table according to claim 5, wherein said plurality of circumferentially present openings (10B) are included in said gutter.

7. Wafer table according to claim 1, wherein said burls (7) are dispersed uniformly over said wafer table (8).

8. Wafer table according to claim 1, wherein said wafer table (8) encompasses the presence of one or more openings that can be opened for release of fluid from said wafer table (8).

9. Wafer table according to claim 1, wherein said wafer table is adapted for being moved into and out of a vacuum environment of the lithography system while the wafer is clamped to the wafer table by means of a stationary layer of liquid which is spaced apart from the gutter and arranged in a gap between the top side of the wafer table and a bottom side of the wafer.

10. Lithography system comprising a wafer table according to claim 1 or claim 9.

11. Wafer table according to claim 1 or 9, wherein the ring has an outer diameter that is greater than the diameter of the wafer, and has an inner diameter that is smaller than the diameter of the wafer.

12. Wafer table according to claim 1 or 9, wherein, when said wafer is supported by said burls, no part of the wafer table projects past a top face of said wafer.

13. Wafer table according to claim 1 or 9, wherein no part of the wafer table projects past the end of said burls that is arranged for contacting the wafer.

14. Lithography system according to claim 10, further comprising dispensing means for dispensing liquid on said top side (2) of the wafer table (8).

15. Lithography system according to claim 10, further comprising [a] the wafer (1) supported by said burls (7) of said wafer table (8), wherein [a] the stationary layer of liquid (3) is included between said wafer table (8) and said wafer [(2)] (1), said stationary layer of liquid contacting both said wafer table (8) and said wafer (1), and wherein said stationary layer of liquid (3) has a thickness which is defined by the height of said burls (7).

16. Lithography system according to claim 10, wherein said stationary layer of liquid (3) is a layer of water.

17. Lithography system according to claim 10, [adapted for projecting] wherein the lithography system is configured to project an image or an image pattern onto said wafer (1) supported by said wafer table (8).

18. Lithography system according to claim 10, adapted for moving said wafer table and wafer (1) clamped thereon relative to a beam source for lithography, by means of an actuated target table or chuck, wherein said wafer table (8) is adapted for loose inclusion in said lithography system without connection of conduits to said wafer table, for treating said wafer (1) carried by the wafer table (8).

14

19. Lithography system according to claim 10, comprising a vacuum environment for processing said wafer while said wafer is clamped to the wafer table by the stationary layer of liquid.

20. A charged particle exposure apparatus configured to expose a charged particle beam on a wafer, the apparatus comprising:

a vacuum environment configured to operate in vacuum conditions;

a first wafer table configured to support a first wafer and be removable from the vacuum environment, wherein the first wafer table is thermally conditioned prior to being placed in the vacuum environment;

a second wafer table configured to support a second wafer and be removable from the vacuum environment, wherein the second wafer table is thermally conditioned prior to being placed in the vacuum environment;

wherein the charged particle exposure apparatus is configured to expose a charged particle beam on the first wafer on the thermally conditioned first wafer table when the wafer is positioned in the vacuum environment, and wherein, after the first wafer is exposed, the first wafer table supporting the first wafer is removed from the vacuum environment and the thermally conditioned second wafer table supporting the second wafer is inserted into the vacuum environment for exposing the second wafer.

21. The charged particle exposure apparatus of claim 20, wherein the first wafer table includes a first clamping mechanism that enables clamping the first wafer to the first wafer table when the first wafer table is positioned outside of the vacuum environment.

22. The charged particle exposure apparatus of claim 20, wherein the second wafer table includes a second clamping mechanism that enables clamping the second wafer to the second wafer table when the second wafer table is positioned outside of the vacuum environment.

23. A method of exchanging a wafer in a charged particle exposure apparatus, wherein the charged particle exposure apparatus is configured to expose a charged particle beam on a wafer when the wafer is in a vacuum environment, the method comprising:

placing a first wafer on a first wafer table;

thermally conditioning the first wafer table supporting the first wafer;

placing the thermally conditioned first wafer table and the first wafer in the vacuum environment;

exposing, in the vacuum environment, the first wafer to a charged particle beam; and

removing the first wafer table supporting the first wafer from the vacuum environment and inserting, into the vacuum environment, a thermally conditioned second wafer table supporting a second wafer for exposing the second wafer to a charged particle beam.

24. The method of claim 23, wherein placing the first wafer on the first wafer table further comprises clamping the first wafer on the first table outside of the vacuum environment.

* * * * *