



US00RE49336E

(19) **United States**  
(12) **Reissued Patent**  
**Kimura et al.**

(10) **Patent Number:** **US RE49,336 E**  
(45) **Date of Reissued Patent:** **\*Dec. 20, 2022**

(54) **PRINTING APPARATUS AND LIQUID STORAGE MEMBER**

(71) Applicant: **CANON KABUSHIKI KAISHA**,  
Tokyo (JP)

(72) Inventors: **Yukimichi Kimura**, Kawasaki (JP);  
**Takahiro Kiuchi**, Fuchu (JP); **Junichi Kubokawa**, Kawasaki (JP); **Kyohei Sato**, Kawasaki (JP); **Koki Shimada**, Kawasaki (JP); **Masaya Shimmachi**, Kawasaki (JP); **Yusuke Tanaka**, Kawasaki (JP); **Hideaki Matsumura**, Kawasaki (JP); **Keiichiro Tsukuda**, Yokohama (JP); **Tatsuo Nanjo**, Kawasaki (JP)

(73) Assignee: **CANON KABUSHIKI KAISHA**,  
Tokyo (JP)

(\*) Notice: This patent is subject to a terminal disclaimer.

(21) Appl. No.: **16/728,460**

(22) Filed: **Dec. 27, 2019**

**Related U.S. Patent Documents**

Reissue of:

(64) Patent No.: **10,118,396**  
Issued: **Nov. 6, 2018**  
Appl. No.: **15/643,225**  
Filed: **Jul. 6, 2017**

U.S. Applications:

(62) Division of application No. 15/296,876, filed on Oct. 18, 2016, now Pat. No. 9,738,081.

(30) **Foreign Application Priority Data**

Oct. 30, 2015 (JP) ..... 2015-214358

(51) **Int. Cl.**

**B41J 2/175** (2006.01)  
**B41J 29/02** (2006.01)

(Continued)

(52) **U.S. Cl.**

CPC ..... **B41J 2/17513** (2013.01); **B41J 2/175** (2013.01); **B41J 2/17509** (2013.01);  
(Continued)

(58) **Field of Classification Search**

CPC ..... **B41J 2/17513**; **B41J 2/17556**; **B41J 2/17553**; **B41J 29/02**; **B41J 29/13**;  
(Continued)

(56) **References Cited**

**U.S. PATENT DOCUMENTS**

5,430,471 A 7/1995 Nakajima et al. .... 347/87  
5,448,274 A \* 9/1995 Hirabayashi ..... 347/86  
(Continued)

**FOREIGN PATENT DOCUMENTS**

CN 1616233 5/2005  
CN 1833870 9/2006  
(Continued)

**OTHER PUBLICATIONS**

Office Action dated Aug. 11, 2020 in counterpart Japanese Application No. 2020-027079, together with English translation thereof.  
(Continued)

*Primary Examiner* — Minh Nguyen

(74) *Attorney, Agent, or Firm* — Venable LLP

(57) **ABSTRACT**

The printing apparatus of the present invention includes: a print head; and a liquid storage container in which a liquid storage chamber that stores a liquid to be supplied to the print head, an atmosphere communication chamber that communicates with the atmosphere, and a communication flow path that causes the liquid storage chamber and the atmosphere communication chamber to communicate are formed integrally. The liquid storage container can take a first posture in which the atmosphere communication chamber is located under the liquid storage chamber in the direction of gravity and a second posture in which the

(Continued)

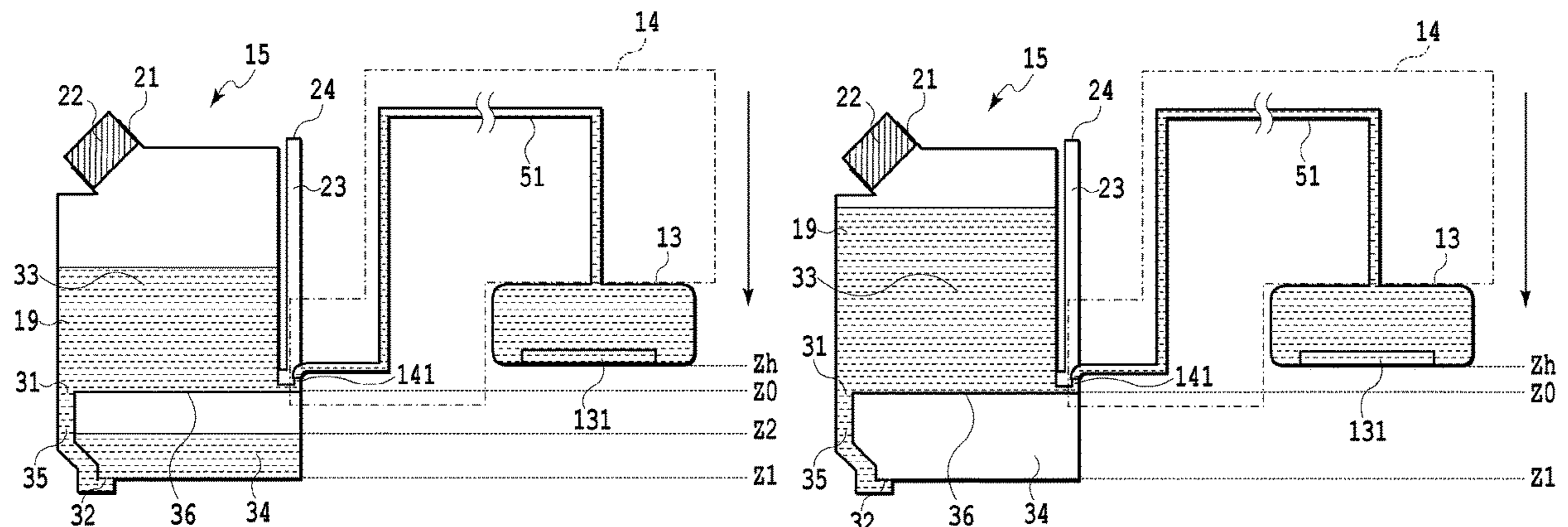

atmosphere communication chamber and the liquid storage chamber are located side by side in the horizontal direction. In the case where the liquid storage container is in the second posture, the liquid injection portion and the communication flow path are located on the upper side of the liquid storage container.

**40 Claims, 9 Drawing Sheets**

- (51) **Int. Cl.**  
*B41J 29/377* (2006.01)  
*B41J 29/13* (2006.01)
- (52) **U.S. Cl.**  
 CPC ..... *B41J 2/17523* (2013.01); *B41J 2/17553* (2013.01); *B41J 2/17556* (2013.01); *B41J 2/17596* (2013.01); *B41J 29/02* (2013.01); *B41J 29/13* (2013.01); *B41J 29/377* (2013.01)
- (58) **Field of Classification Search**  
 CPC ..... B41J 2/175; B41J 29/377; B41J 2/17596; B41J 2/17523; B41J 2/17509  
 See application file for complete search history.

(56) **References Cited**

U.S. PATENT DOCUMENTS

5,504,511	A	4/1996	Nakajima et al.	347/86
5,583,549	A	12/1996	Ujita et al.	347/86
5,589,862	A	12/1996	Ujita et al.	347/87
5,604,523	A	2/1997	Tsukuda et al.	347/86
5,608,437	A	3/1997	Iwata et al.	347/86
5,619,237	A	4/1997	Inoue et al.	347/86
5,781,213	A	7/1998	Ujita et al.	347/86
5,784,088	A	7/1998	Ujita et al.	347/86
5,900,889	A	5/1999	Tsukuda	347/23
5,988,804	A	11/1999	Kotaki et al.	347/87
6,102,533	A	8/2000	Nozawa et al.	347/86
6,152,555	A	11/2000	Nozawa et al.	347/49
6,170,939	B1	1/2001	Ujita et al.	347/86
6,224,201	B1	5/2001	Shigemura	347/93
6,234,615	B1	5/2001	Tsukuda	347/85
6,264,315	B1	7/2001	Nozawa et al.	347/86
6,336,709	B1	1/2002	Inoue et al.	347/49
6,338,546	B1	1/2002	Kotaki et al.	347/49
6,338,551	B1	1/2002	Sato et al.	347/85
6,338,552	B1	1/2002	Sato et al.	347/85
6,361,158	B1	3/2002	Inoue et al.	347/86
6,402,298	B1	6/2002	Nanjo et al.	347/49
6,454,399	B2	9/2002	Ujita et al.	347/86
6,565,199	B2	5/2003	Ujita et al.	347/86
6,702,427	B2	3/2004	Shimizu et al.	347/50
6,712,458	B2	3/2004	Hatasa et al.	347/86
6,783,220	B2	8/2004	Ujita et al.	347/87
6,815,381	B1	11/2004	Yamamoto et al.	442/187
6,824,258	B2	11/2004	Yamamoto et al.	347/86
6,942,325	B2	9/2005	Nanjo	347/86
6,971,741	B2	12/2005	Nanjo et al.	347/85
7,077,514	B2	7/2006	Inoue et al.	347/86
7,104,640	B2	9/2006	Ogura et al.	347/86
7,207,159	B2	4/2007	Nanjo et al.	53/492
7,264,341	B2	9/2007	Katayama	347/86
7,293,865	B2	11/2007	Tsukuda et al.	347/86
7,303,090	B2	12/2007	Nanjo et al.	220/360
7,384,129	B2	6/2008	Nagata et al.	347/43
7,401,909	B2	7/2008	Inoue et al.	347/86
7,407,274	B2	8/2008	Inoue et al.	347/86
7,407,275	B2	8/2008	Inoue et al.	347/86
7,552,837	B2	6/2009	Nanjo et al.	220/360
7,686,442	B2	3/2010	Katsumura	347/92
7,775,646	B2	8/2010	Yamaguchi	347/86
7,914,137	B2	3/2011	Inoue et al.	347/86
8,002,396	B2	8/2011	Yamada	347/86

8,047,641	B2	11/2011	Nanjo et al.	347/86
8,197,043	B2	6/2012	Watanabe et al.	347/85
8,205,974	B2	6/2012	Ogura et al.	347/86
8,425,022	B2	4/2013	Inoue et al.	347/86
8,678,567	B2	3/2014	Shimizu et al.	347/85
8,678,572	B2	3/2014	Kawate	347/86
8,733,916	B2	5/2014	Kinoshita	347/92
8,770,730	B2	7/2014	Nanjo et al.	347/86
8,770,731	B2	7/2014	Miyashita et al.	347/86
8,960,869	B2	2/2015	Takada et al.	347/86
9,016,842	B2	4/2015	Miyashita et al.	347/86
9,033,479	B2	5/2015	Kawate	347/86
9,079,413	B2	7/2015	Kudo et al.	B41J 2/17556
9,102,162	B2	8/2015	Watanabe et al.	B41J 2/16532
9,109,132	B2	8/2015	Nakano et al.	C08K 5/3415
9,144,985	B2	9/2015	Koike et al.	B41J 2/175
9,289,999	B2	3/2016	Koike et al.	B41J 2/17513
9,375,938	B2	6/2016	Kondo et al.	B41J 2/1752
9,381,748	B2	7/2016	Kimura et al.	B41J 2/175
9,409,407	B2	8/2016	Kudo et al.	B41J 29/02
9,567,473	B2	2/2017	Nakano et al.	C09D 11/322
9,605,172	B2	3/2017	Aoki et al.	C09D 11/324
9,815,295	B2	11/2017	Kudo et al.	B41J 2/19
9,878,551	B2	1/2018	Shimizu et al.	B41J 2/17523
2001/0017642	A1	8/2001	Shigemura	347/85
2002/0140789	A1	10/2002	Tajima et al.	347/87
2005/0099473	A1	5/2005	Katayama	347/86
2006/0028514	A1	2/2006	Balducci et al.	347/84
2006/0082626	A1	4/2006	Oikawa et al.	347/86
2007/0236549	A1	10/2007	Yamada	347/87
2008/0198207	A1	8/2008	Katada	347/85
2012/0038719	A1*	2/2012	Shimizu	B41J 2/175 347/86
2012/0188315	A1	7/2012	Kawate	347/87
2013/0169720	A1	7/2013	Nakamura et al.	B41J 2/175
2013/0187995	A1	7/2013	Kobashi et al.	B41J 2/17556
2013/0235133	A1	9/2013	Watanabe et al.	347/92
2014/0043408	A1	2/2014	Kudo et al.	B41J 2/17556
2014/0125743	A1	5/2014	Aruga	347/86
2014/0160210	A1	6/2014	Kawate	347/86
2015/0049144	A1	2/2015	Aoki et al.	347/85
2015/0049146	A1	2/2015	Nakano et al.	347/86
2015/0049147	A1*	2/2015	Nakano	B41J 2/17513 347/87
2015/0109378	A1	4/2015	Koike et al.	347/85
2015/0109379	A1	4/2015	Koike et al.	347/85
2015/0306882	A1	10/2015	Kudo et al.	347/87
2015/0352853	A1	12/2015	Kudo et al.	347/86
2015/0367648	A1	12/2015	Kimura et al.	347/86
2016/0200113	A1	7/2016	Nanjo et al.	347/86
2016/0200114	A1	7/2016	Nanjo et al.	347/86
2017/0120608	A1	5/2017	Takaoka et al.	B41J 2/17506
2017/0120609	A1	5/2017	Kimura et al.	B41J 2/17509
2017/0120612	A1	5/2017	Fukuchi et al.	B41J 2/17553
2017/0120613	A1	5/2017	Ikebe et al.	B41J 2/17553

FOREIGN PATENT DOCUMENTS

CN	101049763	10/2007
CN	104085197	10/2014
CN	104553338	4/2015
EP	0773109	5/1997
JP	H08-90785	4/1996
JP	H09-323430	12/1997
JP	2007-144643	6/2007
JP	2010-208151	9/2010
JP	2012-051308	3/2012
JP	2012-061624	3/2012
JP	2012-196777	10/2012
JP	2013-067111	4/2013
JP	2013-146977	8/2013
JP	2013-151100	8/2013
JP	2013-151101	8/2013
JP	2013-184424	9/2013
JP	2014-054823	3/2014
JP	2014-054826	3/2014
JP	2014-079932	5/2014
JP	2014-156125	8/2014
JP	2014-177033	9/2014

(56)

**References Cited**

FOREIGN PATENT DOCUMENTS		
JP	2014-195908	10/2014
JP	2015-044379	3/2015
JP	2015-061749	4/2015
JP	2015-147423	8/2015
JP	2015-178281	10/2015
JP	2015-091670	5/2016
JP	2017-013242	1/2017
JP	2017-077652	4/2017
KR	10-1999-0014249	2/1999
KR	10-0517102 B	9/2005
KR	10-2012-0041254	4/2012
KR	10-1484827 B1	1/2015
KR	10-2016-0044584	4/2016
WO	2013/085023	6/2013
WO	2014/112344	7/2014
WO	2015/059926	4/2015

**OTHER PUBLICATIONS**

Office Action dated Feb. 4, 2020 in counterpart Korean Application No. 10-2019-0143148, together with English Translation thereof.  
 Office Action dated Jan. 29, 2021 in counterpart Korean Application No. 10-2019-0143148, together with English Translation thereof.  
 Office Action dated May 26, 2020 in counterpart Japanese Application No. 2020-027079, together with English translation thereof.  
 Office Action dated Sep. 17, 2020 in counterpart Korean Application No. 10-2019-0143148, together with English Translation thereof.  
 Office Action dated Apr. 7, 2020 in counterpart Chinese Application No. 201910293315.2, together with English translation thereof.  
 Chinese Office Action dated Aug. 24, 2018 issued in counterpart Chinese Application No. 201601963802.1 (with whole English Translation).  
 Office Action dated Sep. 11, 2018 in counterpart Japan Application No. 2015-214358, together with English translation thereof.

\* cited by examiner

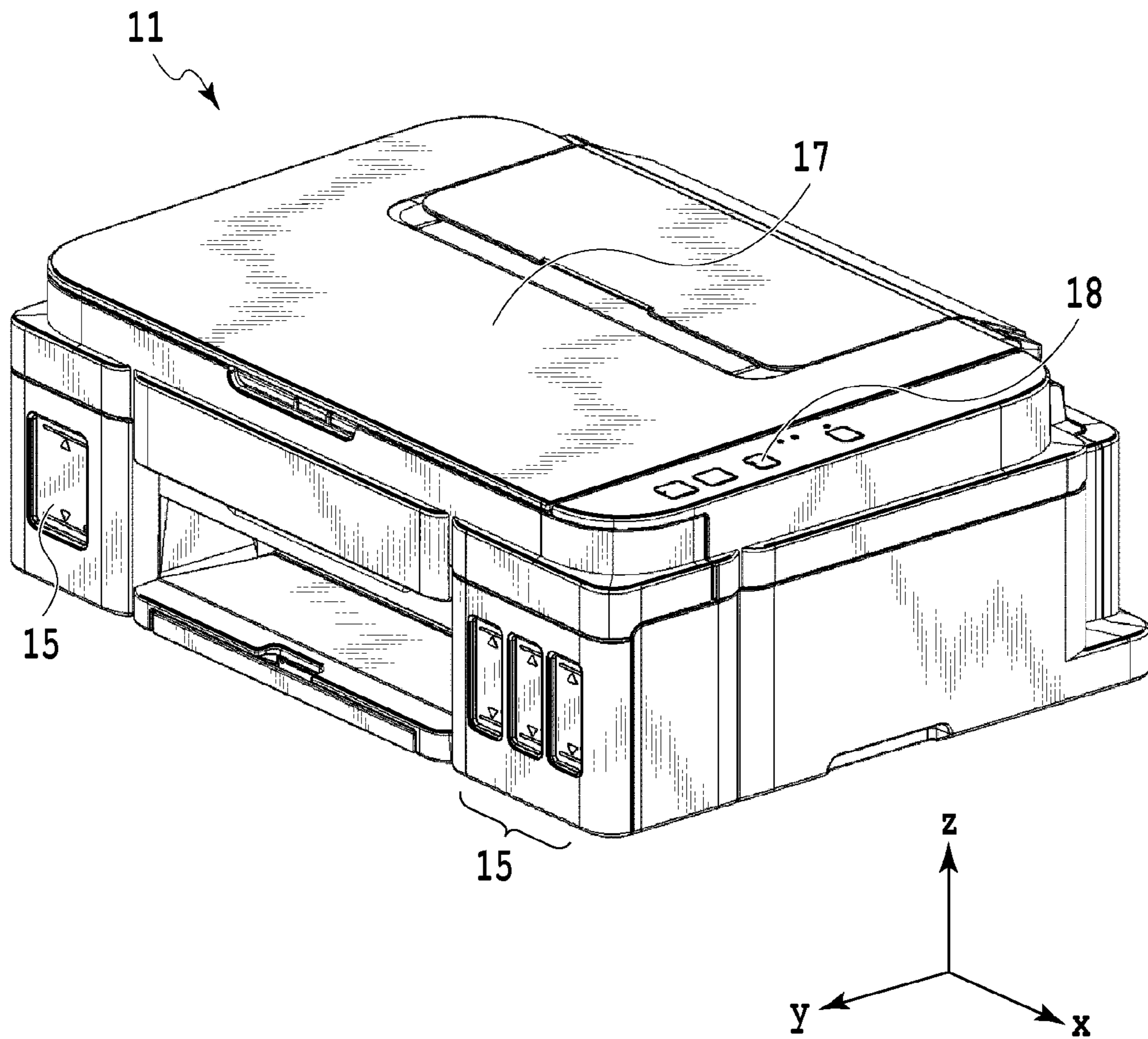

FIG.1

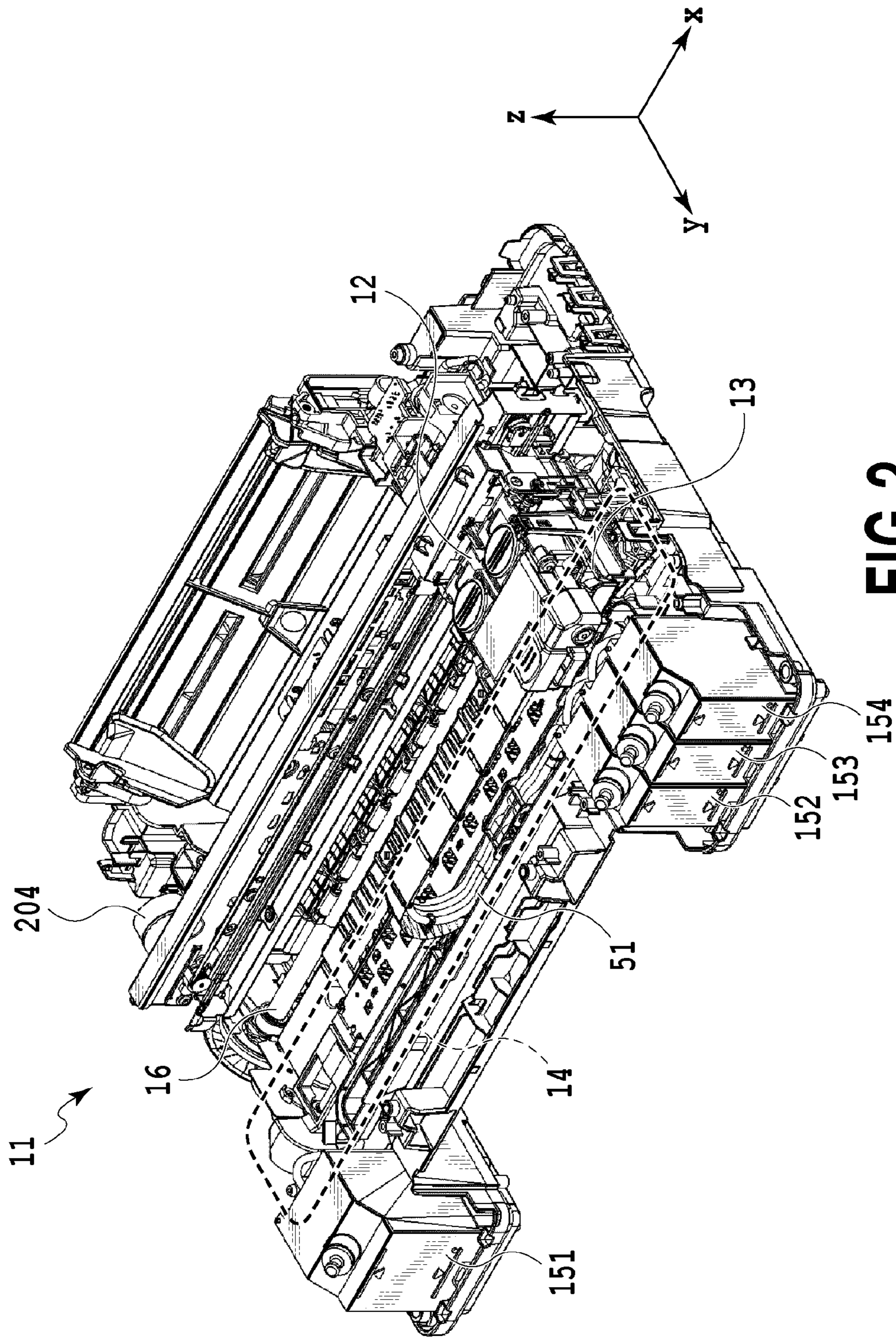

FIG. 2

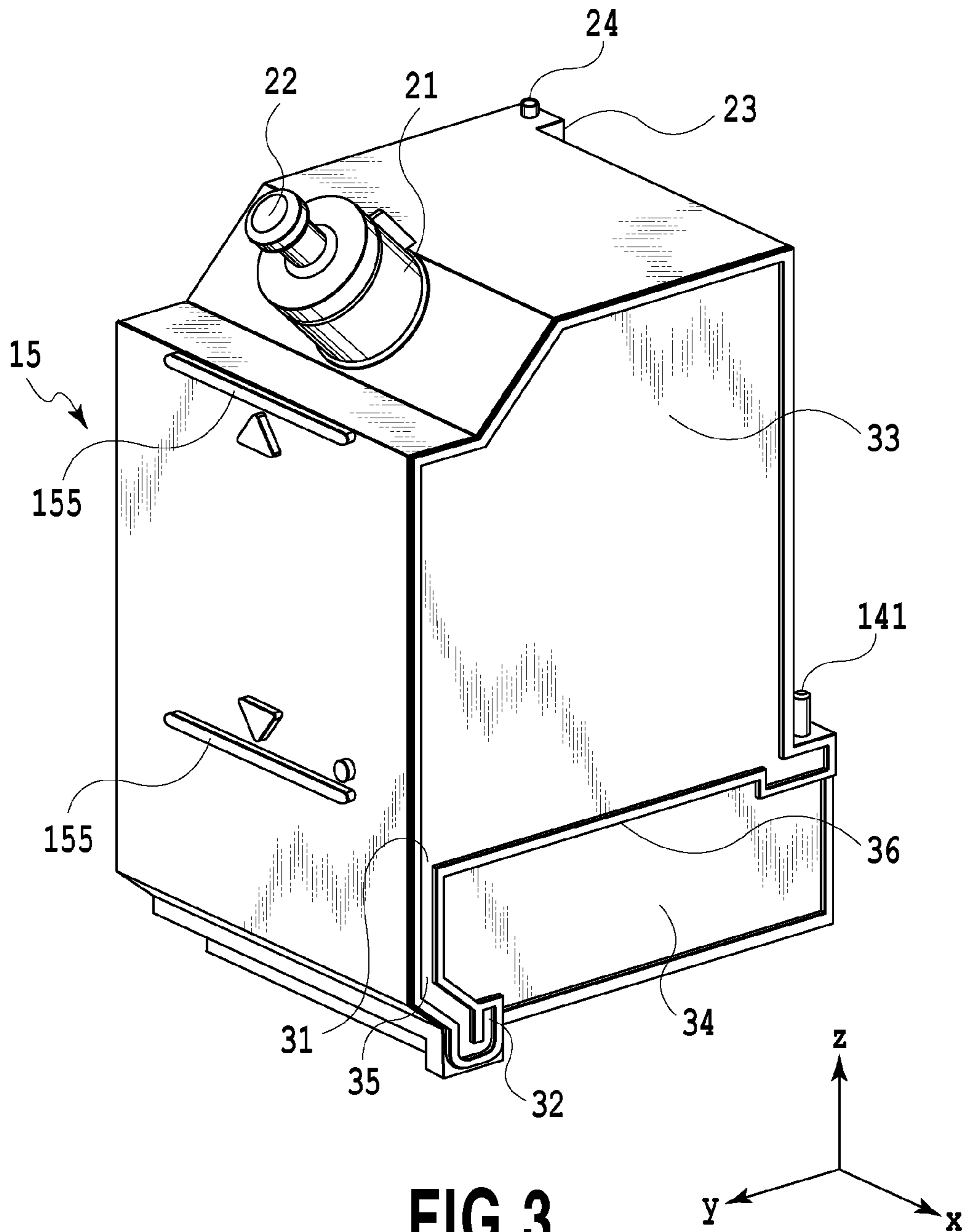

FIG. 3

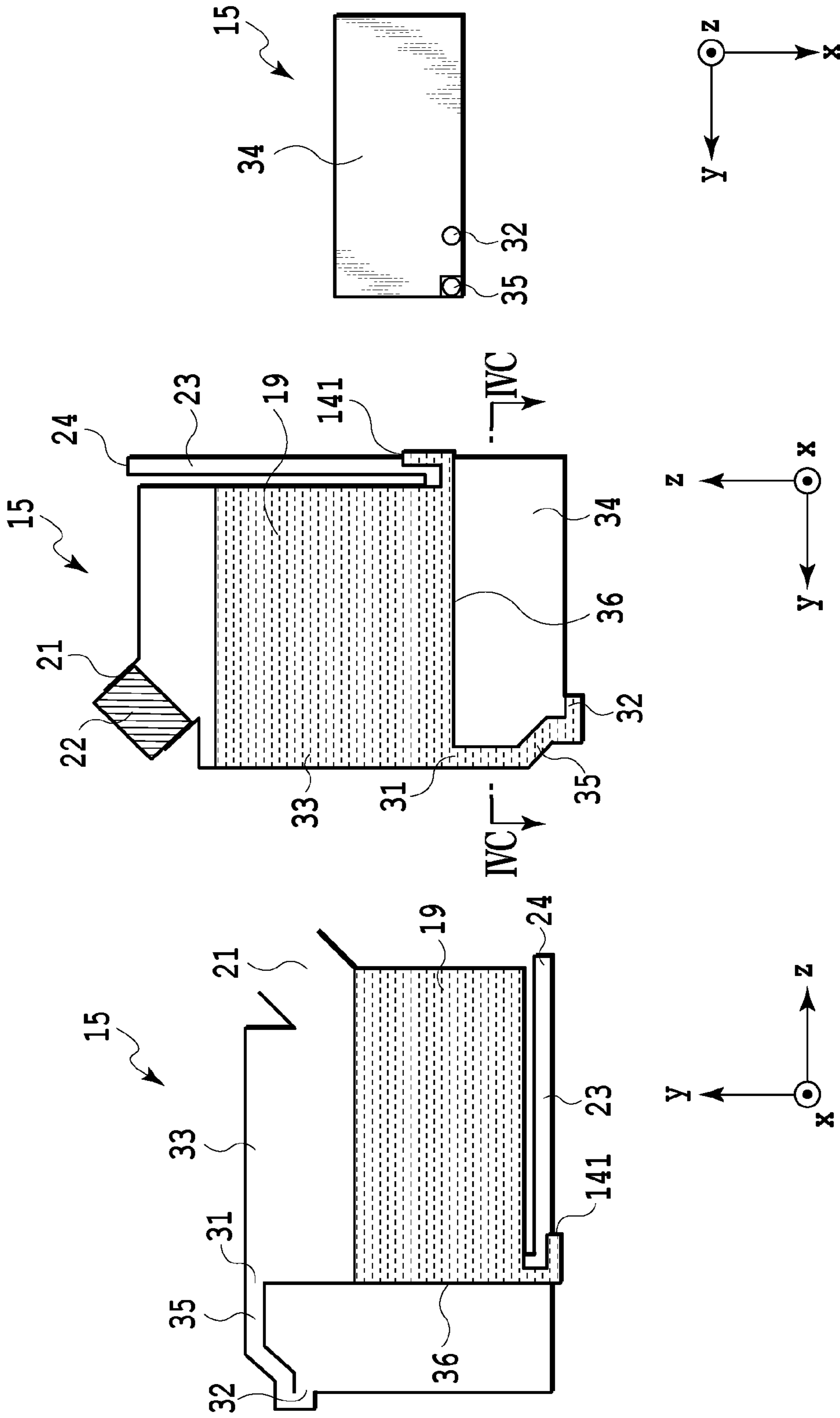
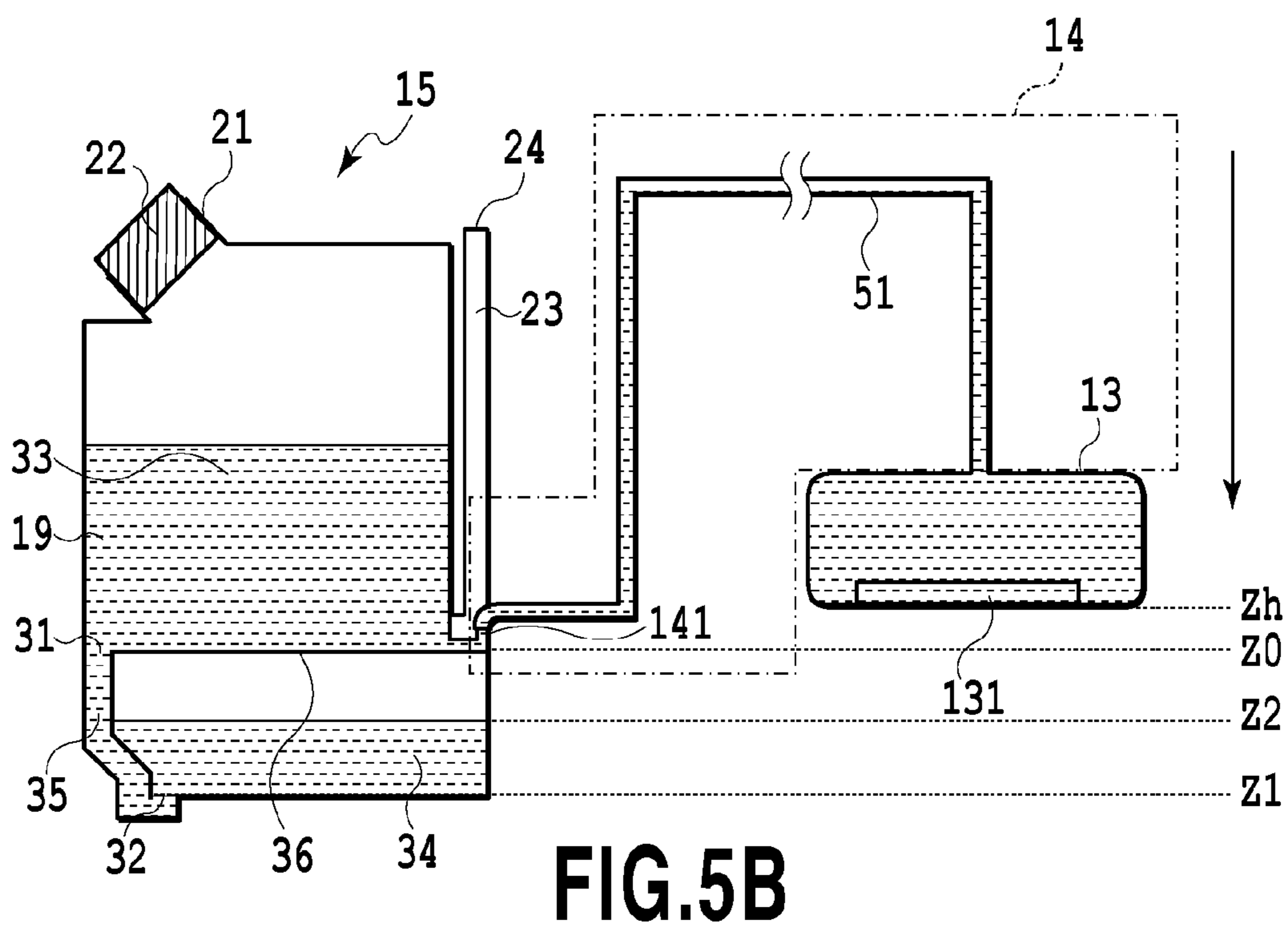
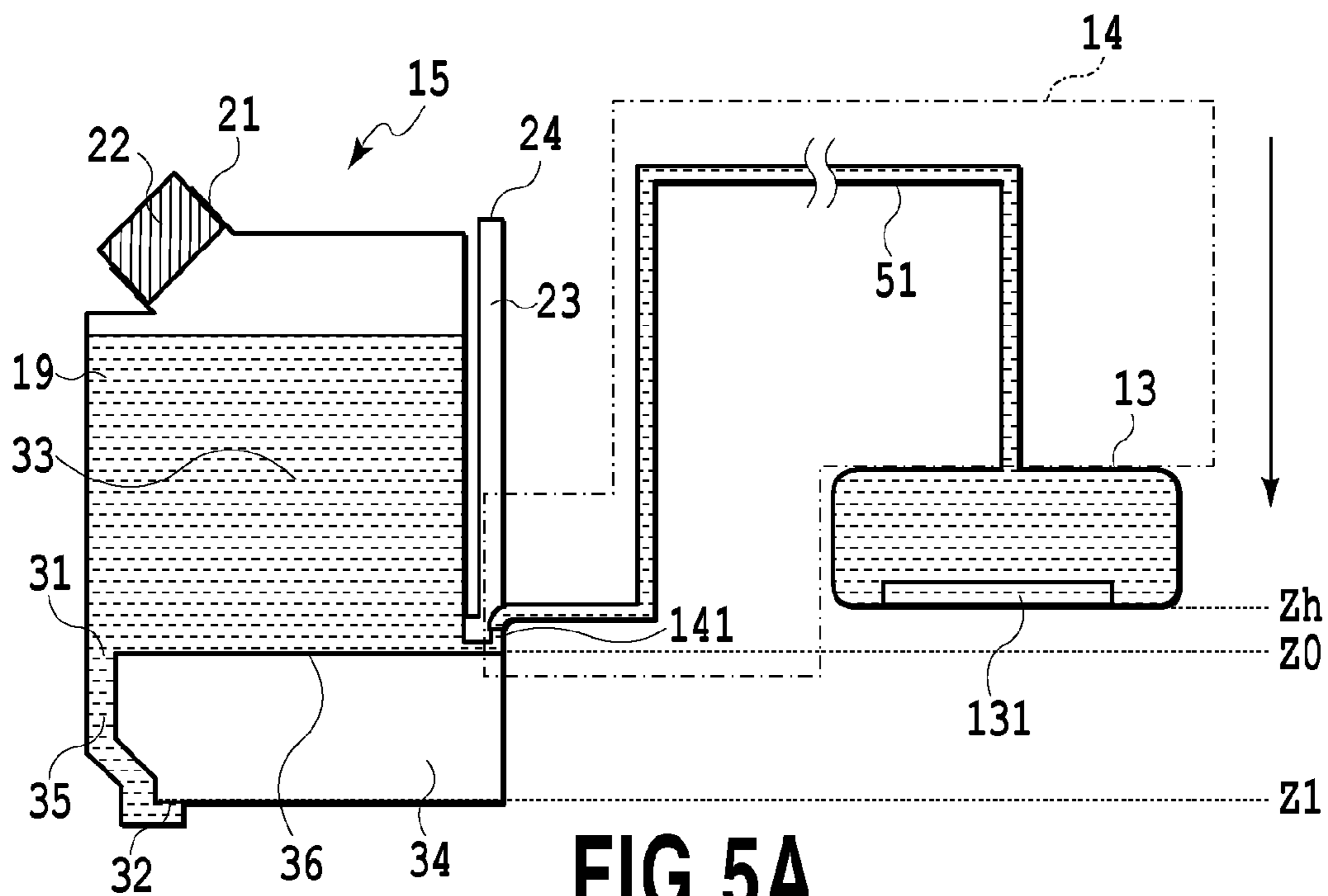

FIG.4C

FIG.4B

FIG.4A





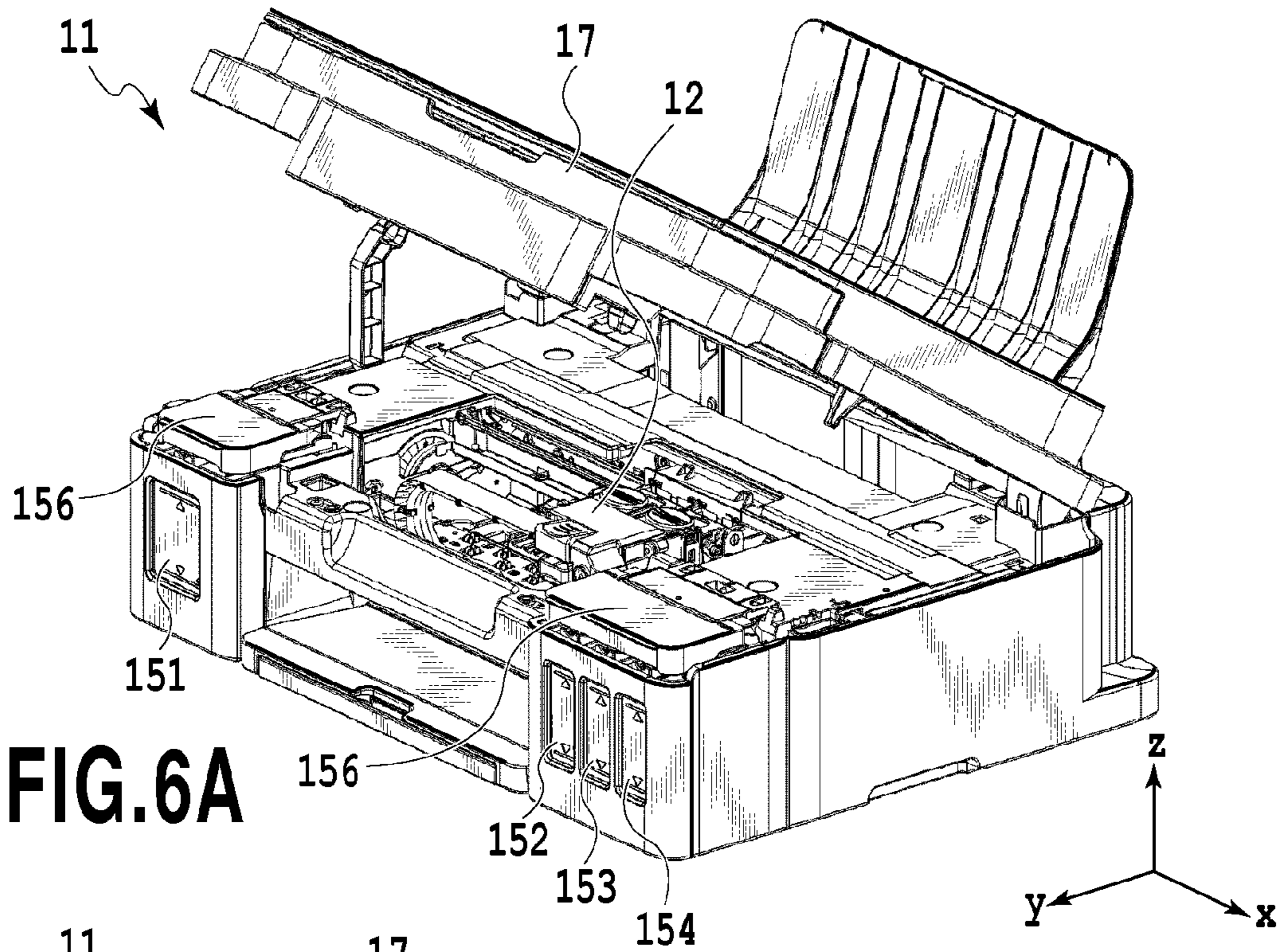

**FIG. 6A**

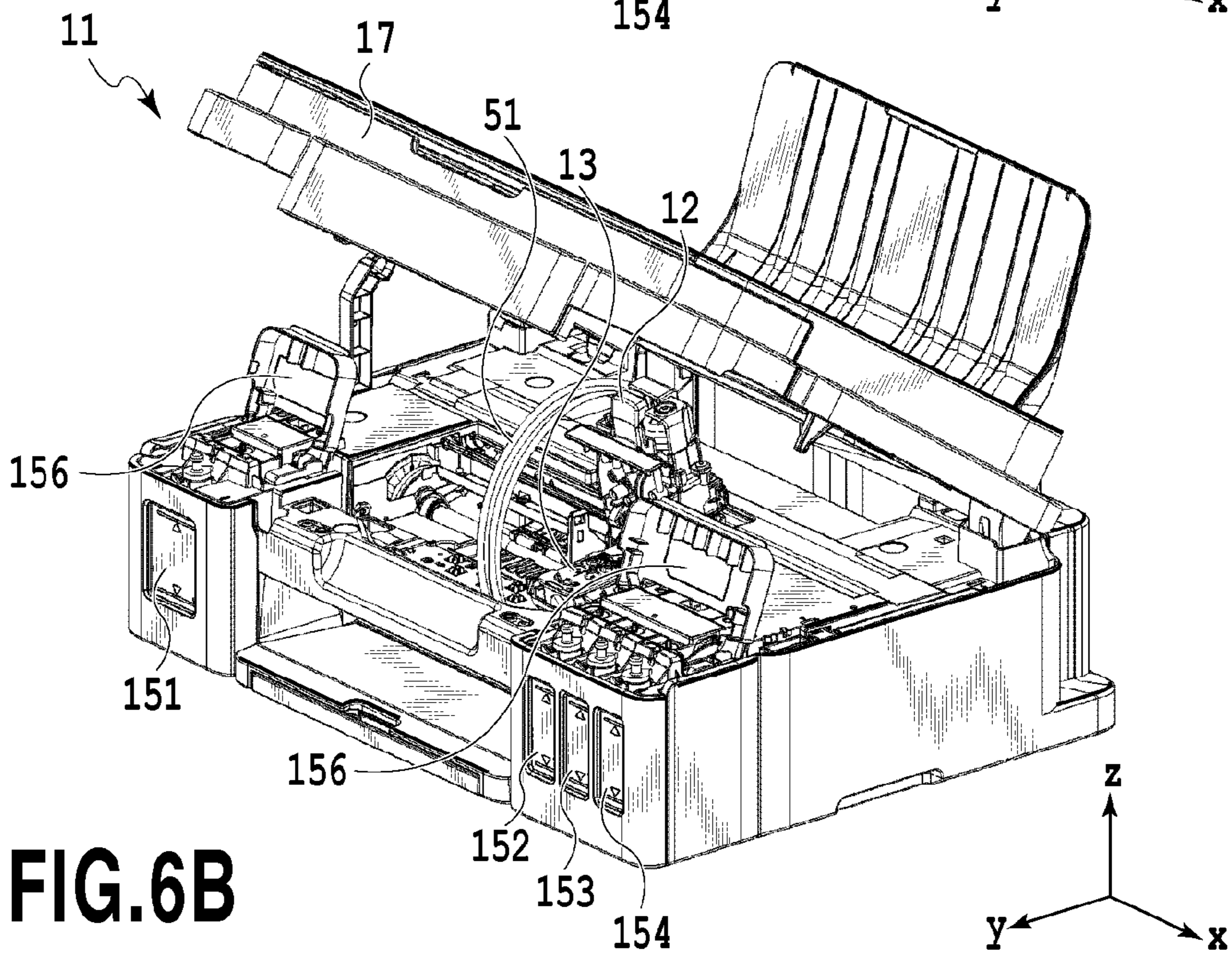

**FIG. 6B**

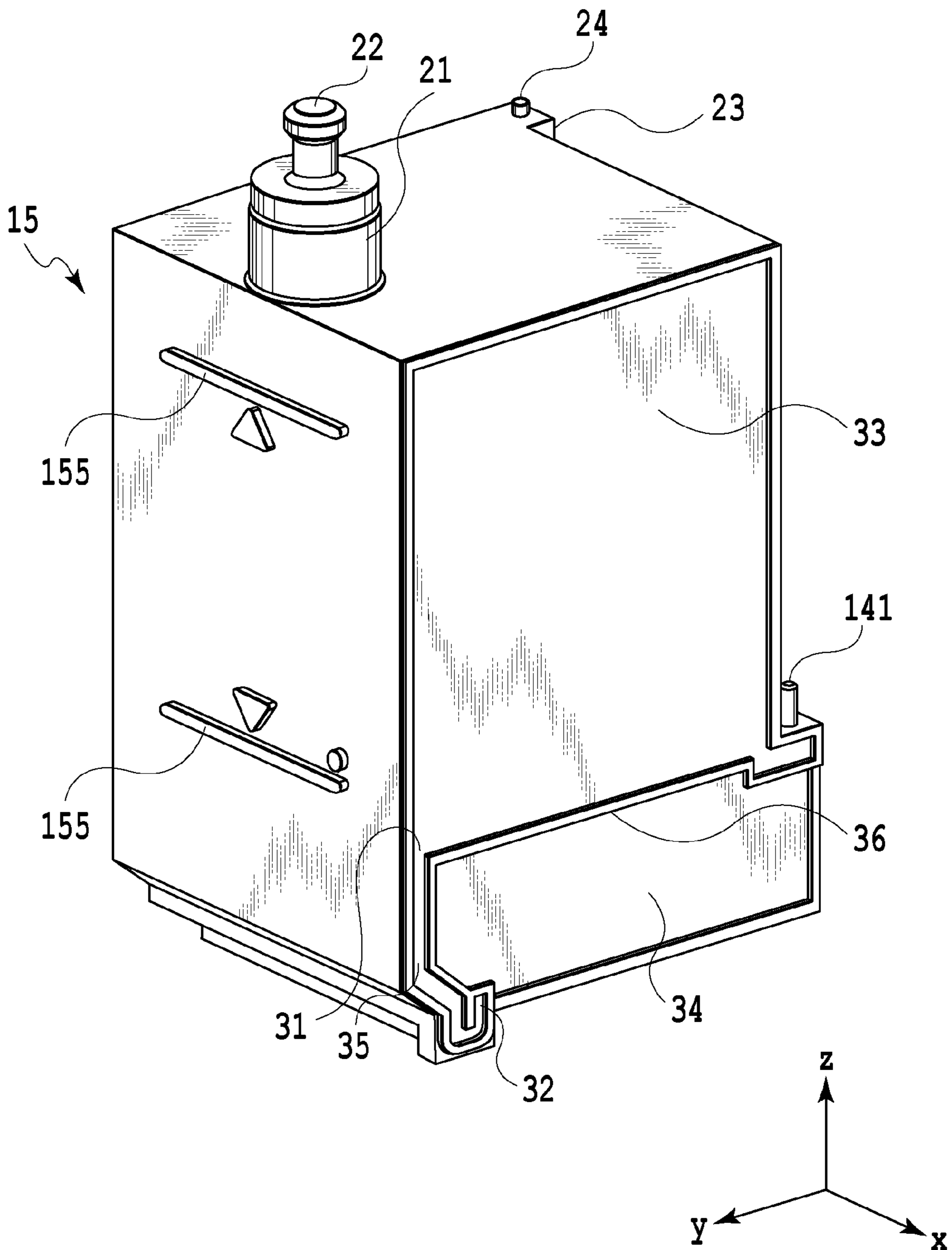

FIG. 7

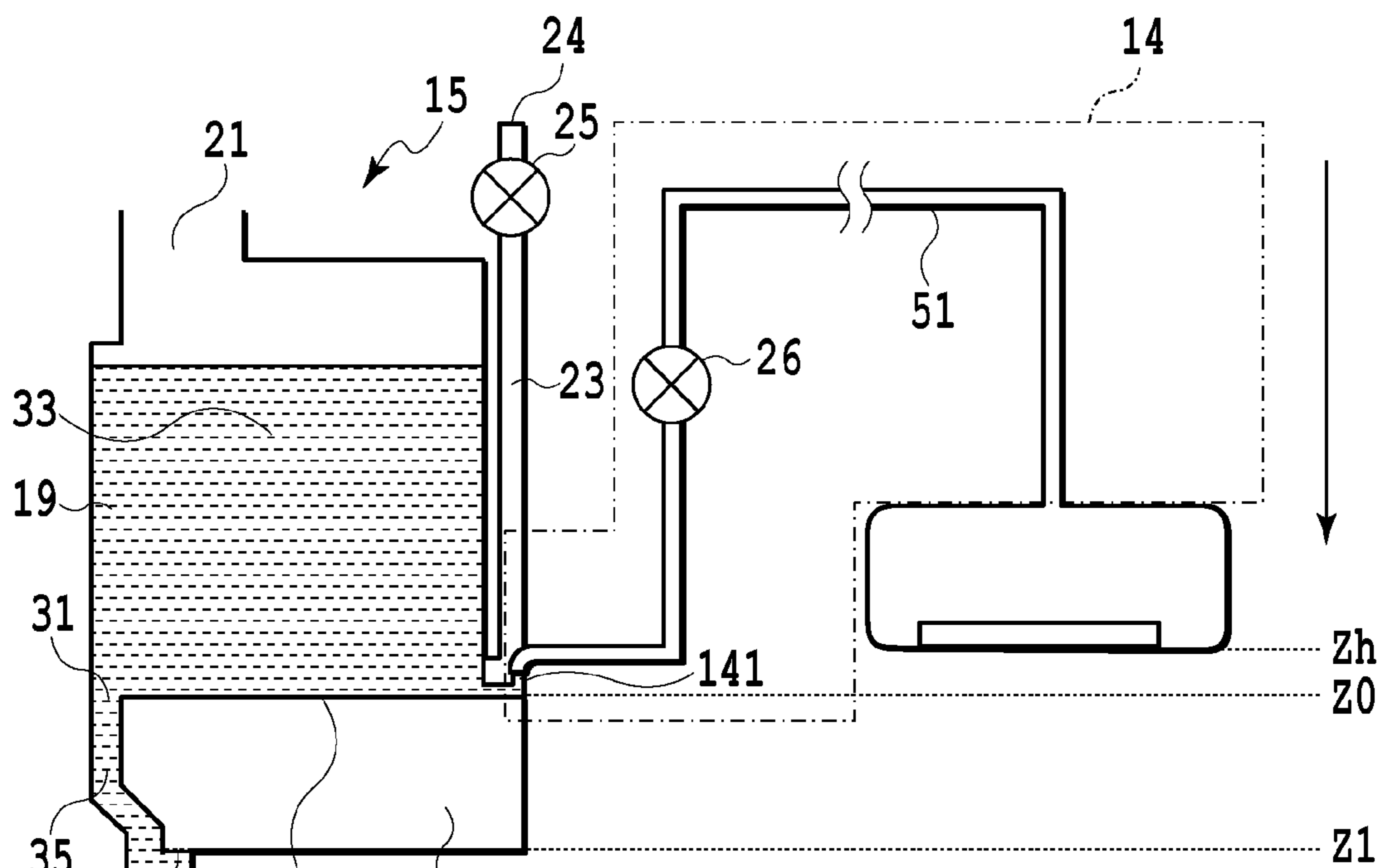

FIG. 8A

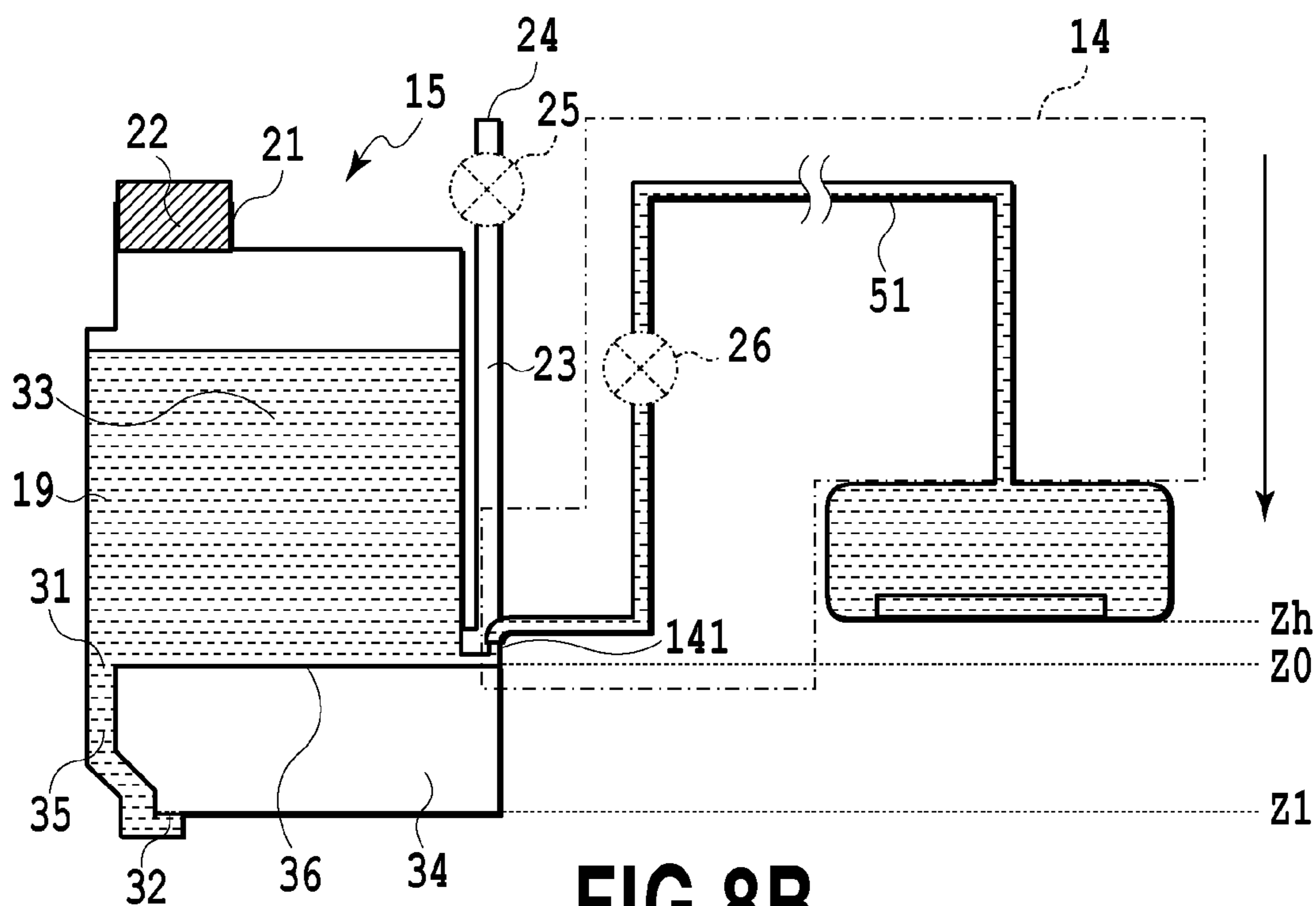
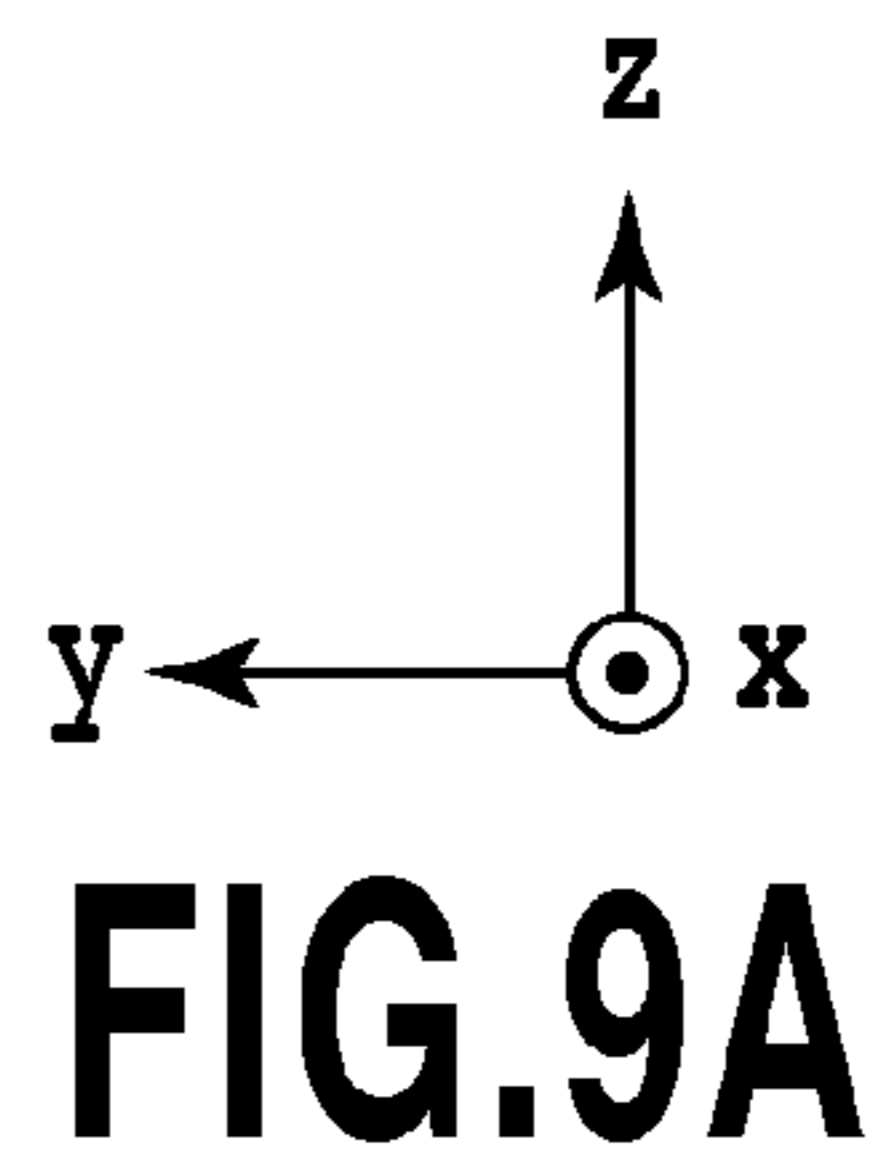
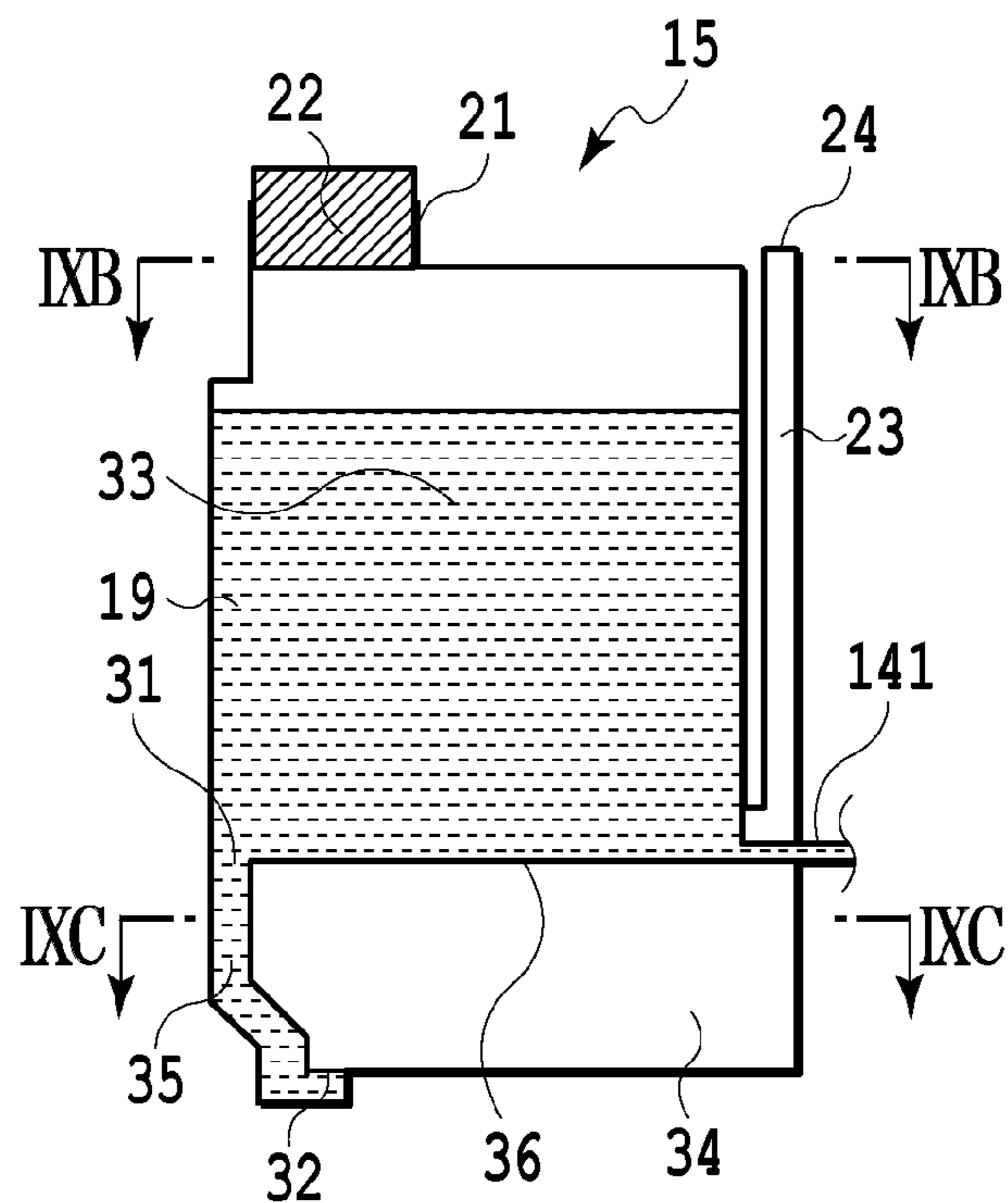
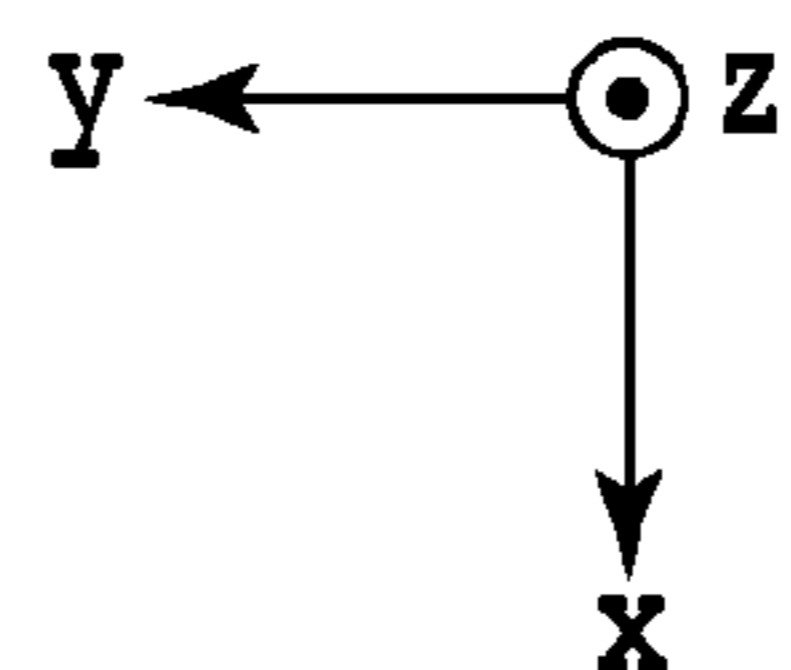
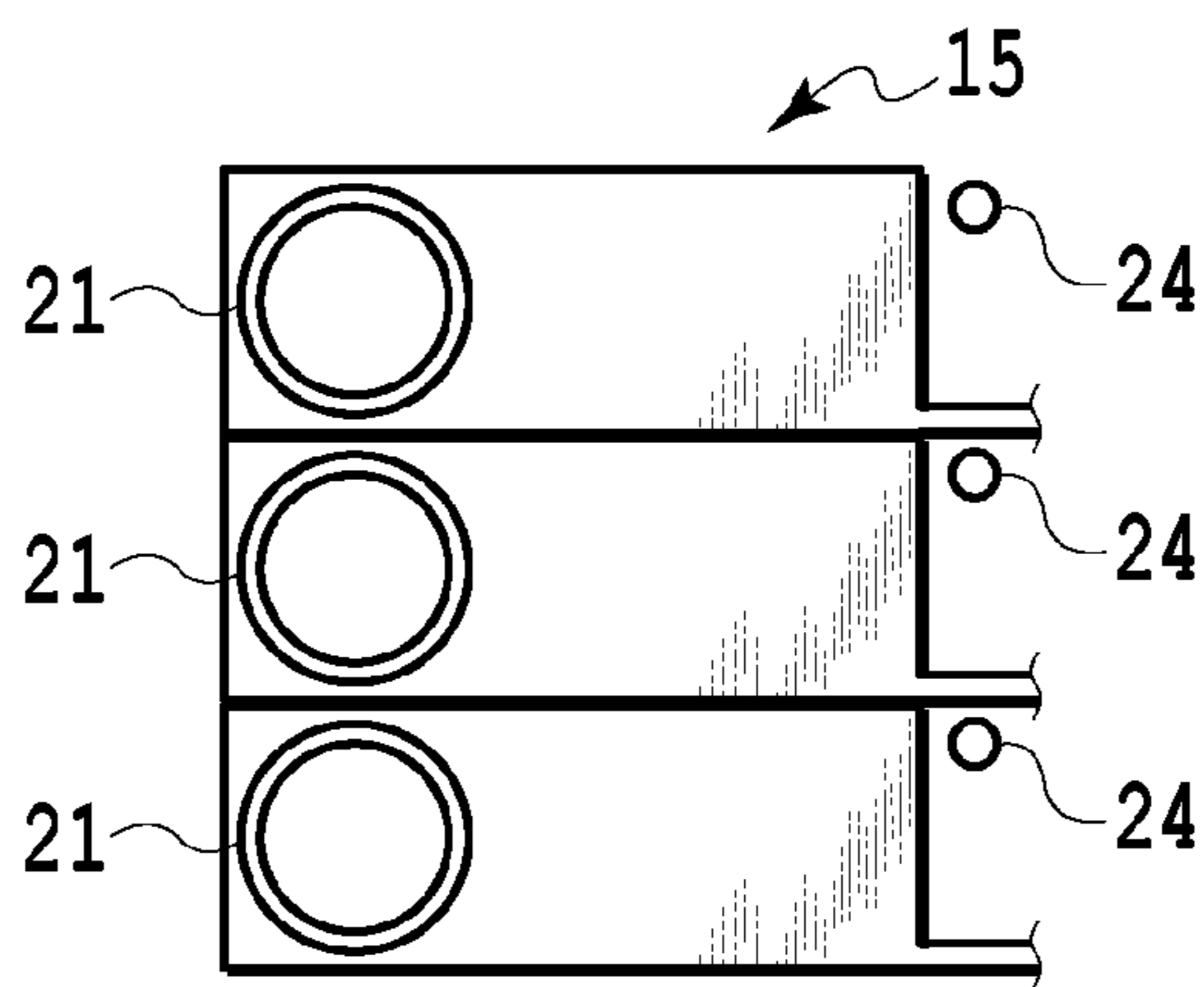

FIG. 8B



**FIG. 9A**



**FIG. 9B**

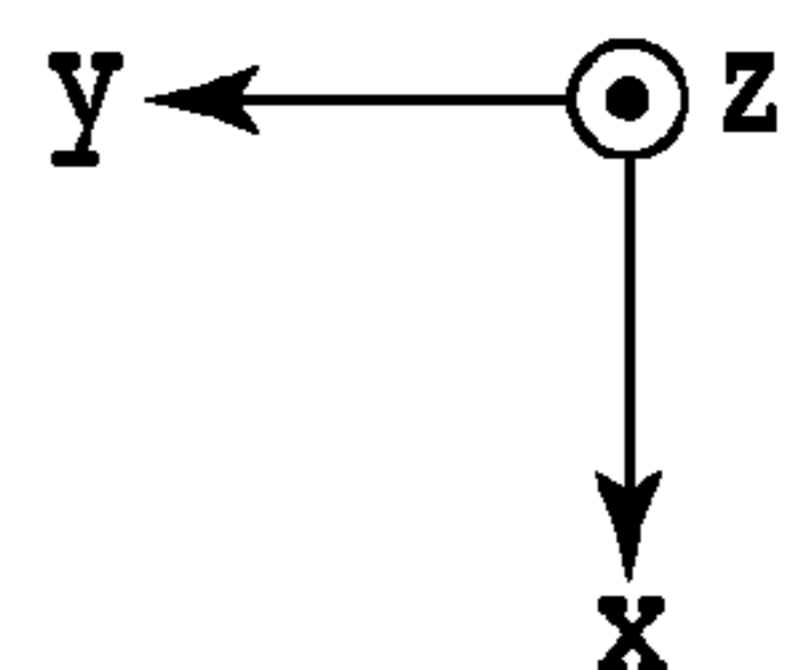
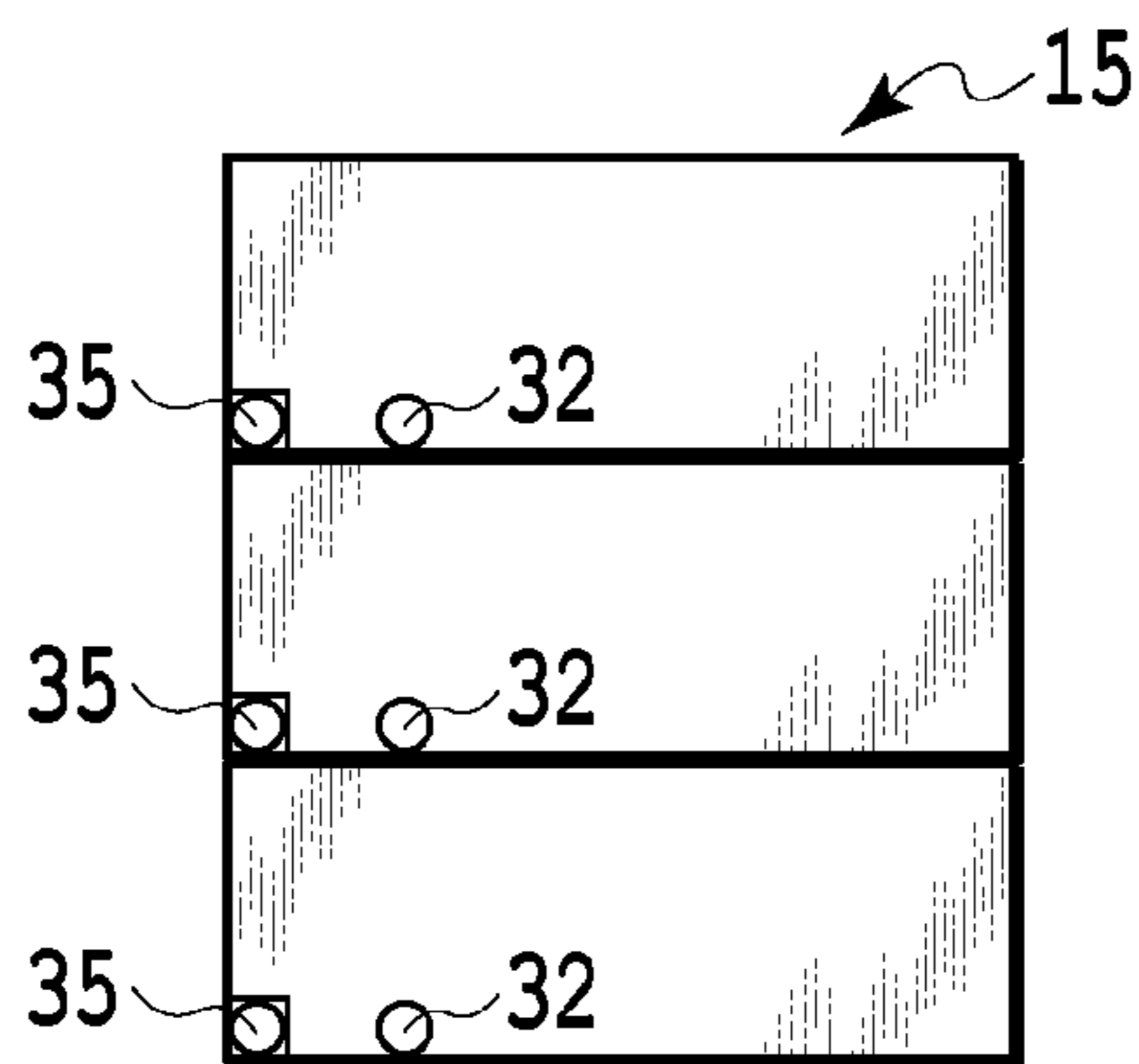

**FIG. 9C**

## PRINTING APPARATUS AND LIQUID STORAGE MEMBER

**Matter enclosed in heavy brackets [ ] appears in the original patent but forms no part of this reissue specification; matter printed in italics indicates the additions made by reissue; a claim printed with strikethrough indicates that the claim was canceled, disclaimed, or held invalid by a prior post-patent action or proceeding.**

[This application is a division of application Ser. No. 15/296,876 filed Oct. 18, 2016, and claims priority under 35 U.S.C. § 119 to Japan Application 2015-214358 filed in Japan on Oct. 30, 2015; and the contents of all of which are incorporated herein by reference as if set forth in full.]

*Notice: More than one reissue application has been filed for the reissue of U.S. Pat. No. 10,118,396. The reissue application numbers are 16/728,460 (this application) and 17/750,772, which is a continuation reissue of this application and a reissue of U.S. Pat. No. 10,118,396.*

*This application is for reissue of U.S. Pat. No. 10,118,396 issued Nov. 6, 2018, which was filed as U.S. patent application Ser. No. 15/643,225 on Jul. 6, 2017, and which is a division of U.S. patent application Ser. No. 15/296,876 filed Oct. 18, 2016, now issued as U.S. Pat. No. 9,738,081 on Aug. 22, 2017; and claims priority under 35 U.S.C. § 119 to Japan Application No. 2015-214358 filed in Japan on Oct. 30, 2015; and the contents of all of which are incorporated herein by reference as if set forth in full.*

### BACKGROUND OF THE INVENTION

#### Field of the Invention

The present invention relates to a printing apparatus that performs a printing operation by ejecting ink onto a printing medium and a liquid storage member used in a printing apparatus.

#### Description of the Related Art

For a conventional ink jet printing apparatus, there is a configuration including a head that ejects ink, an ink tank that stores ink, and an ink flow path that connects the head and the ink tank (Japanese Patent Laid-Open No. 2010-208151). The ink tank has a buffer tank communicating with the atmosphere and is designed so that air flows into the ink tank from the buffer tank in the case where ink is consumed in the head.

In the ink jet printing apparatus described in Japanese Patent Laid-Open No. 2010-208151, the opening of a communication flow path through which the ink tank and the buffer tank communicate within the buffer than is arranged under an ejection port surface of the head so as to prevent ink from leaking out of the head. Due to the configuration such as this, the interior of the head is maintained in the negative pressure state by a hydraulic head difference.

### SUMMARY OF THE INVENTION

In the field of the ink jet printing apparatus, there exists an ink jet printing apparatus including an injection port through which ink can be injected into an ink tank from the top of the ink tank. In the ink jet printing apparatus such as this, it is difficult to maintain the negative pressure state

within the head by making use of the hydraulic head difference as in Japanese Patent Laid-Open No. 2010-208151.

That is, in the configuration of the ink jet printing apparatus described in Japanese Patent Laid-Open No. 2010-208151, the injection port is provided on the top of the ink tank and in the case where the injection port opens, the ink tank is caused to communicate with the atmosphere via the injection port. In this case, there is a possibility that the ink within the ink tank leaks out to the outside through the buffer tank and the atmosphere communication port of the buffer tank.

An object of the present invention is to provide a printing apparatus or a liquid storage member that suppresses ink from leaking out to the outside at the time of ink injection in a configuration in which an injection port is provided to an ink tank. The printing apparatus of the present invention includes a print head that performs a printing operation by ejecting a liquid, a liquid storage container in which a liquid storage chamber that stores the liquid to be supplied to the print head, an atmosphere communication chamber that communicates with the atmosphere, and a communication flow path that causes the liquid storage chamber and the atmosphere communication chamber to communicate are formed integrally, and a liquid injection portion provided on the liquid storage container and configured to be injected the liquid into the liquid storage chamber from the outside, and the liquid storage container can take a first posture in which the atmosphere communication chamber is located under the liquid storage chamber in the direction of gravity and a second posture in which the atmosphere communication chamber and the liquid storage chamber are located side by side in the horizontal direction, and in the case where the posture of the liquid storage container is the second posture, the liquid injection portion and the communication flow path are located on the upper side of the liquid storage container.

Further features of the present invention will become apparent from the following description of exemplary embodiments (with reference to the attached drawings).

### BRIEF DESCRIPTION OF THE DRAWINGS

FIG. 1 an external perspective view of a printing apparatus in an embodiment;

FIG. 2 is a perspective view showing an internal configuration of the printing apparatus in the embodiment;

FIG. 3 is an external perspective view of an ink tank in the embodiment;

FIG. 4A is a schematic diagram showing a section (second posture state) of the ink tank in the embodiment;

FIG. 4B is a schematic diagram showing a section (first posture state) of the ink tank in the embodiment;

FIG. 4C is a section view along IVC-IVC line of the ink tank in the embodiment;

FIG. 5A is a section view showing an ink-filled state in the printing apparatus of the embodiment;

FIG. 5B is a section view showing the ink-filled state in the printing apparatus of the embodiment;

FIG. 6A is an external perspective view of a printing apparatus in a second embodiment;

FIG. 6B is an external perspective view of the printing apparatus in the second embodiment;

FIG. 7 is an external perspective view of an ink tank in the second embodiment;

FIG. 8A is a section view showing an ink-filled state in the printing apparatus of the second embodiment;

3

FIG. 8B is a section view showing the ink-filled state in the printing apparatus of the second embodiment;

FIG. 9A is a schematic diagram showing a section of an ink tank in a third embodiment;

FIG. 9B is a section view along IXB-IXB line of the ink tank in the embodiment; and

FIG. 9C is a section view along IXC-IXC line of the ink tank in the embodiment.

## DESCRIPTION OF THE EMBODIMENTS

### First Embodiment

Hereinafter, embodiments of the present invention are explained in detail with reference to the attached drawings. Explanation is given by attaching the same symbols to the same configurations through each drawing. In the present embodiment, as a printing apparatus, a serial-type ink jet printing apparatus **11** (hereinafter, described as a "printing apparatus") is explained as an example.

FIG. 1 is an external perspective view showing an outline of the printing apparatus **11** in the present embodiment. As shown in FIG. 1, the printing apparatus **11** of the present embodiment includes a casing, a printing unit (not shown) configured to perform a printing operation mainly on a printing medium (not shown), and an ink tank **15** that stores ink in the printing unit. In the present embodiment, the ink tank **15** is arranged on the front surface of the casing of the printing apparatus **11**. On the top of the casing, a scanner unit **17**, an operation input unit **18** capable of receiving an input of instructions or the like by a user, etc., are arranged. For explanation, the coordinate axes are set so that the main scanning direction of the printing apparatus **11** is the X axis, the sub scanning direction is the Y axis, and the direction perpendicular to the X axis and the Y axis is the Z axis. Through each drawing, each of the directions of the X, Y, and Z axes indicates the same direction.

FIG. 2 is a perspective view showing an internal configuration of the printing apparatus **11** in the present embodiment. As shown in FIG. 2, the printing apparatus **11** includes a paper feed roller (not shown), a conveyance roller **16**, and a paper discharge roller (not shown) as a configuration for conveying a printing medium in the form of a sheet. Further, the printing apparatus **11** includes a maintenance unit (not shown) of a print head **13**, a main chassis, a timing belt, and a carriage motor **204**.

A carriage **12** receives a drive from the carriage motor **204** via the timing belt while being supported by the main chassis and moves along the main scanning direction perpendicular to the conveyance direction of a printing medium. Due to the configuration such as this, it is possible for the print head **13** to reciprocate along the main scanning direction together with a carriage **12**. In the vicinity of the carriage **12**, a code strip for detecting the position of the carriage **12** is installed in a stretched state in parallel to the timing belt. In the code strip, for example, markings are formed at a pitch of 150 to 300 per inch. On the other hand, on the carriage **12**, an encode sensor for reading the code strip is mounted.

In the present embodiment, it is possible for the print head **13** to eject inks of four colors (cyan, magenta, yellow, black) and ejection units **131** each ejecting each of the inks of four colors are arranged in parallel to one another in the main scanning direction. The ejection unit **131** is formed by, for example, an ejection port (nozzle) corresponding to each of the inks of four colors and an ejection port formation surface, to be described later, refers to a surface on which the ejection port in the print head **13** is formed. The print head

4

**13** prints an image by ejecting each ink to a printing medium based on image data input to the printing apparatus **11**. The printing medium may be any medium on which an image can be formed by landing ink droplets. For example, it is possible to use those of various materials and in various forms, such as paper, cloth, an optical disk label surface, a plastic sheet, an OHP sheet, and an envelope. Further, the printing apparatus **11** includes an ink flow path **14** of each ink corresponding to the ink of each color of the print head **13** and can supply the ink of each color to the print head from the ink tank **15**. The printing apparatus **11** of the present embodiment includes four kinds of ink tank: a tank for black **151**, a tank for cyan **152**, a tank for magenta **153**, and a tank for yellow **154**.

Further, the printing apparatus **11** includes a maintenance unit within a movement range in the scanning direction of the carriage **12**. The maintenance unit includes a recovery unit configured to perform recovery processing of the print head **13** and is arranged so as to face the ejection unit **131**, to be described later. The recovery unit includes a cap unit configured to cap the ejection unit **131** and a suction mechanism configured to forcibly suck in ink in the capped state to remove the residual bubbles and the ink of which the viscosity has been increased within the ejection unit **131**. By the recovery processing of the recovery unit, the function of the print head **13** is recovered and at the same time, the ejection characteristics of the print head are maintained.

FIG. 3 is an external perspective view of the ink tank **15** in the present embodiment. As in FIG. 1, the Y-axis direction indicates the longitudinal direction (hereinafter, sometimes described as "the front side and the rear side") of the printing apparatus **11** and the Z-axis direction indicates the height direction (hereinafter, sometimes described as "the top side and the bottom side"). The ink tank **15** in FIG. 3 is the ink tank **15** in the "first posture state", to be described later in FIG. 4B.

As shown in FIG. 3, on the front side in the longitudinal direction of the ink tank **15**, an index **155** indicating the amount of ink in an ink storage chamber **33** is formed. On an inclined surface on the top-front side of the ink tank **15**, an ink injection port **21** through which ink is injected into the ink storage chamber (into the liquid storage chamber) is arranged. To the ink injection port **21**, a tank cap **22** is attached in an attachable/detachable manner. In the present embodiment, in the direction of gravity, on the top of the ink tank **15**, the ink storage chamber **33** that stores ink is arranged and at the bottom of the ink tank, a buffer space **34** capable of temporarily storing ink is arranged. The ink injection port **21** communicates with the ink storage chamber **33** and receives injection of ink from the outside of the ink tank **15**. The ink tank **15** and the ink injection port **21** configure the liquid storage container (liquid storage member) and the liquid injection portion, respectively, in the present invention. The ink storage chamber **33** and the buffer space **34** configure the liquid storage chamber and the atmosphere communication chamber, respectively, in the present invention.

The ink storage chamber **33** and the buffer space **34** communicate via a communication flow path **35**. In the present embodiment, the ink storage chamber **33** and the buffer space **34** share part of the bottom surface of the ink storage chamber **33** so that the bottom surface serves as the ceiling surface of the buffer space **34**. It can be said that the bottom surface of the ink storage chamber **33** and the ceiling surface of the buffer space **34** are partition walls **36** that define the ink storage chamber **33** and the buffer space **34**.

As shown in FIG. 3, the communication flow path 35 is arranged on the bottom-front side of the ink tank 15. In the first posture of the ink tank 15, one end of the communication flow path 35 is connected to the bottom surface side of the ink storage chamber 33 and the other end of the communication flow path 35 is connected to the bottom surface side of the buffer space 34. Further, in the ink tank 15 of the present embodiment, the ink storage chamber 33, the buffer space 34, and the communication flow path 35 are formed integrally.

An ink outflow unit 141 communicates with the ink storage chamber 33 and supplies ink to the print head 13 by causing the ink to flow out. The ink outflow unit 141 is formed in the vicinity of the bottom surface of the ink storage chamber 33. The ink outflow unit 141 configures the liquid outflow unit in the present invention.

The buffer space 34 and the outside of the ink tank 15 communicate via an atmosphere communication flow path 23 including an atmosphere opening 24 that opens into the atmosphere. In the present embodiment, the atmosphere communication flow path 23 is arranged on the rear side of the ink tank 15 and the atmosphere opening 24 is arranged in the vicinity of the top of the ink tank 15. Due to the configuration such as this, in the case where the ink in the ink storage chamber 33 is consumed in the state of being hermetically closed by the tank cap 22, it is possible to take in the outside air via the atmosphere communication flow path 23 and the atmosphere opening 24. It is possible for the ink tank 15 of the present embodiment to store the ink in the buffer space 34, which is pushed out by the expanded air, in the case where the air within the ink storage chamber 33 expands due to the fluctuations in pressure or the change in temperature as in the case of the ink tank described in Japanese Patent Laid-Open No. 2010-208151. Due to the configuration such as this, it is possible to prevent the ink that is pushed out by the expanded air and which flows backward through the atmosphere communication flow path 23 from leaking out through the atmosphere opening 24.

FIG. 4A to FIG. 4C are each a schematic diagram showing a section of the ink tank 15 in the present embodiment. FIG. 4A is a schematic diagram showing the ink tank 15 in the second posture state and FIG. 4B is a schematic diagram showing the ink tank 15 in the first posture state. FIG. 4C is a section view along IVC-IVC line in FIG. 4B. In the present embodiment, the ink tank 15 is configured so as to be capable of being removable from the printing apparatus 11 and is formed so as to be capable of changing into the first posture state and the second posture state before and after attachment/detachment. In the present embodiment, the ink outflow unit 141 is connected to the ink flow path 14 also after attachment/detachment.

FIG. 4A shows the second posture state, which is the posture of the ink tank 15 in the case where ink is injected. The second posture refers to the posture in which the ink tank 15 is arranged so that the buffer space 34 and the ink storage chamber 33 are put side by side in the horizontal direction. Further, in the case where the posture of the ink tank 15 is the second posture, the ink injection port 21 and the communication flow path 35 are located on the upper side of the ink tank 15 and the ink outflow unit 141 is located on the lower side of the ink tank 15. After being detached from the printing apparatus 11, the ink tank 15 is tilted so that the communication flow path 35 and the ink injection port 21 are located on the top side (the top side is in the positive Y-axis direction). Next, after the tank cap 22 is detached, it is made possible to inject ink into the ink tank 15. Even in the case where ink is injected through the ink

injection port 21 in the second posture state, the communication flow path 35 is always located above the liquid surface of an ink 19 in the ink storage chamber 33, and therefore, the ink 19 does not flow into the buffer space 34 via the communication flow path 35. After the ink is injected, the ink injection port 21 of the ink tank 15 is closed by the tank cap 22.

In the present embodiment, at the time of ink injection, in the case where the liquid surface within the ink tank 15 is at a height position that does not exceed a height position (Zh) of the ejection port formation surface of the head in the second posture (see FIG. 4A), it is made possible to inject ink into the ink tank 15 without the need to provide an open/close valve in the ink flow path 14. That is, in the second posture, even in the state where the ink injection port 21 is open, there exists a hydraulic head difference necessary to maintain the negative pressure within the head, and therefore, it becomes more unlikely that the ink leaks out of the head.

Further, in the case where an open/close valve is provided in the ink flow path 14, it is no longer necessary to take into consideration the position (hydraulic head difference) of the ink tank at the time of ink injection, and it is also possible to more securely suppress the leakage of ink at the time of ink injection.

FIG. 4B shows the first posture state, which is the posture of the ink tank 15 in the case of being attached to the printing apparatus 11 after ink injection. The first posture refers to the posture in which the buffer space 34 is located under the ink storage chamber 33 in the direction of gravity. The ink tank 15 of the present embodiment is attached to the printing apparatus 11 in the above-described first posture state. At this time, in the ink tank 15, the ink injection port 21 is hermetically closed by the tank cap 22, and therefore, air does not enter the ink tank 15 through the ink injection port 21. In the first posture, one end of the communication flow path 35 is connected to the bottom surface side of the ink storage chamber 33 and the other end is connected to the bottom surface side of the buffer space 34. Further, the communication flow path 35 and the opening 32 are arranged on the bottom-front side (the front side is in the positive Y-axis direction) of the ink tank 15 and the atmosphere opening 24 is arranged on the top-rear side (the top side is in the positive Z-axis direction) of the ink tank 15.

As shown in FIG. 4C, in the first posture state, the opening 32 of the communication flow path 35 in the buffer space 34 is formed on the bottom surface of the buffer space 34 facing the upper side in the direction of gravity. Due to the configuration such as this, a meniscus is formed in the opening 32 of the communication flow path 35, and therefore, the ink in the ink storage chamber 33 does not flow out into the buffer space 34 located ahead of the opening 32.

FIG. 5A and FIG. 5B are each a schematic section view showing an ink-filled state of the ink tank 15 and the print head 13 in the printing apparatus 11 of the present embodiment. A tube 51 extends from the ink outflow unit 141 of the ink tank 15 and communicates with the print head 13 and is used to cause the ink 19 in the ink storage chamber 33 to flow out to be supplied to the print head 13. In the present embodiment, the ink outflow unit 141 and the tube 51 configure the ink flow path 14. Further, the tube 51 configures the second communication flow path of the present invention.

FIG. 5A shows a state where up to the inside of the print head 13 is filled with the ink within the ink storage chamber 33 via the ink flow path 14. In the state where the print head 13 is filled with ink in FIG. 5A, in the case where the ink in

the print head 13 is ejected through the ink ejection unit 131, it is possible for the print head 13 to receive supply of ink corresponding to the amount of consumed ink from the ink storage chamber 33.

In FIG. 5A, the arrow indicates the direction of gravity and the "height" in the following explanation of FIGS. 5A and 5B and FIGS. 8A and 8B means the height in the direction of gravity.

The height of the ejection port formation surface, which is the arrangement surface on which the ejection units 131 are arranged side by side, is taken to be  $Z_h$  and the lowest position in the ink flow path 14, which is the flow path connecting the ink outflow unit 141 and the print head 13, is taken to be  $Z_0$ . In the present embodiment, the ink outflow unit 141 is provided at the position the height of which is the same as that of the bottom surface (partition wall surface of the partition wall 36) of the ink storage chamber 33.

Further, the height of the position of the opening 32 in the communication flow path 35 is taken to be  $Z_1$ . At this time, the height  $Z_1$  corresponds to the liquid surface height of ink at which the gas-liquid exchange between the ink and the atmosphere is performed as the ink is consumed by the print head 13.

As described previously, the buffer space 34 is located under the ink storage chamber 33 in the direction of gravity, and therefore, the position ( $Z_1$ ) of the opening 32 is arranged on the lower side of the height ( $Z_h$ ) of the ejection port formation surface of the print head 13. Due to the configuration such as this, it is possible for the printing apparatus 11 of the present embodiment to cause a hydraulic head difference to occur between  $Z_h$  and  $Z_1$  and to favorably keep the negative pressure within the print head 13. Further, in the printing apparatus 11 of the present embodiment, a meniscus is formed also in the ejection port (ejection unit 131), and therefore, the backflow of ink into the ink storage chamber 33 is prevented, which is caused by air being mixed through the ejection port.

FIG. 5B shows a state where the air within the ink storage chamber 33 expands due to the fluctuations in the pressure and the change in temperature and the ink 19 in the ink storage chamber 33 is pushed out into the buffer space 34. A height  $Z_2$  of the ink liquid surface in the buffer space 34 corresponds to the height at which the gas-liquid exchange between the ink and the atmosphere is performed.

The height  $Z_2$  of the ink liquid surface is arranged under the height ( $Z_h$ ) of the ejection port formation surface of the print head 13. Because of this, even in the case where the ink 19 is pushed out into the buffer space 34, the negative pressure within the print head 13 does not change reversely to the positive pressure immediately, and therefore, it is unlikely that the ink leaks out of the print head 13.

Further, by limiting the height ( $Z_2$ ) of the ink liquid surface in the buffer space 34 to the position ( $Z_0$ ) of the partition wall surface or lower, which is the surface of the partition wall 36, the height ( $Z_2$ ) is always lower than the height of the ejection port formation surface of the print head 13, and therefore, it is possible to stably keep the negative pressure within the print head.

By limiting the height ( $Z_2$ ) of the ink liquid surface in the buffer space 34 to the position ( $Z_0$ ) of the partition wall surface or lower and further setting the lowest position in the ink flow path 14 to the position ( $Z_0$ ) of the partition wall surface or higher, the ink flow path 14 will always be located at the position higher than the height ( $Z_2$ ) of the ink liquid surface. Because of this, even in the case where air is mixed within the ink flow path 14, it is possible to favorably keep the negative pressure within the print head. Due to the

configuration such as this, it is possible for the printing apparatus 11 of the present embodiment to favorably keep the negative pressure within the print head 13 even in the case where ink is stored in the buffer space 34.

As explained above, it is possible for the ink tank 15 of the present embodiment to take the first posture in which the buffer space 34 is located under the ink storage chamber 33 in the direction of gravity and the second posture in which the buffer space 34 and the ink storage chamber 33 are located side by side in the horizontal direction. Due to the configuration such as this, it is unlikely for the printing apparatus 11 of the present embodiment to cause the atmosphere to communicate through the ink injection port in the state where the negative pressure in the print head 13 is kept favorably. Because of this, even in the case of a configuration in which the ink injection port 21 is provided to the ink tank 15, it is possible to suppress ink from leaking out to the outside at the time of ink injection.

## Second Embodiment

FIG. 6A and FIG. 6B are each an external perspective view showing an outline of the printing apparatus 11 in the present embodiment. FIG. 6A is an external perspective view illustrating a state where the scanner unit 17 of the printing apparatus 11 of the present embodiment is open and FIG. 6B is an external perspective view showing a state where the carriage 12 and an ink tank cover 156 of the printing apparatus 11 are open. In explanation of the present embodiment, the same symbols are attached to the same configurations as those of the first embodiment and explanation of the duplicated contents is omitted.

As shown in FIG. 6A, the canner unit 17 is configured so as to be capable of being opened from and closed to the casing of the printing apparatus 11 and by lifting the canner unit 17, an open area is formed.

As shown in FIG. 6B, the carriage 12 and the ink tank cover 156 are configured so as to be capable of being opened/closed. It is made possible for a user to exchange the print head 13 with another by lifting the carriage 12 and to access the ink tank 15 by lifting the ink tank cover 156. Further, the tube 51 that communicates with each ink tank is connected and via the tube 51, each ink is supplied to the print head 13. As in the first embodiment, the ink outflow unit 141 and the tube 51 configure the ink flow path 14. In the present embodiment, a valve 26 is provided that connects the ink outflow unit 141 and the print head 13, opens/closes the tube 51 through which ink is supplied from the ink storage chamber 33 to the print head 13, and cuts out communication between ink and air.

FIG. 7 is an external perspective view showing the ink tank 15 in the present embodiment. The buffer space 34 and the outside of the ink tank 15 communicate with each other via the atmosphere communication flow path 23 and the atmosphere opening 24. The atmosphere communication flow path 23 is arranged on the rear side of the ink tank 15 and the atmosphere opening 24 is arranged in the vicinity of the top of the ink tank 15. In the present embodiment, a valve 25 is provided that opens/closes the atmosphere communication flow path 23 that causes the buffer space 34 and the atmosphere opening 24 to communicate and cuts off the communication of air.

FIG. 8A and FIG. 8B are each a schematic section view showing an ink-filled state of the ink tank 15 and the print head 13 in the printing apparatus 11 of the present embodiment.



FIG. 8A shows a state where ink is injected into the ink storage chamber 33. That is, in the present embodiment, it is possible to inject ink in the posture (first posture) shown in FIG. 8A. In the present embodiment, at the time of ink injection, the valves 25 and 26 are closed and ink is injected through the ink injection port 21. The ink 19 stored in the ink storage chamber 33 does not flow out into the buffer space located ahead of the opening 32.

FIG. 8B shows a state where the valves 25 and 26 are opened after ink is injected into the ink tank 15 and the tank cap 22 is attached. After the valves 25 and 26 are opened, the ink stored in the ink storage chamber 33 fills the print head 13 through the ink flow path 14. As described above, in the printing apparatus 11 of the present embodiment, because the valves 25 and 26 are provided, it is possible to inject ink into the ink tank 15 also in the posture (first posture) at the time in use without the need to detach the ink tank 15 from the printing apparatus 11.

As explained above, according to the printing apparatus 11 of the present embodiment, the effect that it is possible to provide a printing apparatus with good operability is obtained in addition to the effect by the first embodiment.

### Third Embodiment

FIG. 9A to FIG. 9C are each a schematic diagram showing a section of the ink tank 15 in the present embodiment. FIG. 9A shows a section of the ink tank 15 in the first posture state and FIG. 9B and FIG. 9C show a section view along IXB-IXB line in FIG. 9A and a section view along IXC-IXC line in FIG. 9A, respectively. In explanation of the present embodiment, the same symbols are attached to the same configurations as those of the above-described embodiments and explanation of the duplicated contents is omitted.

In the above-described embodiments, the aspect is explained in which the ink tank 15 stores one kind of ink in the one ink storage chamber 33 and in the one buffer space 34. However, the embodiments are not limited to those described above.

That is, as shown in FIG. 9B and FIG. 9C, the ink tank 15 of the present embodiment has a plurality of ink storage chambers each storing each of a plurality of kinds of ink and a plurality of the buffer spaces 34 each corresponding to each of the plurality of ink storage chambers. Due to the configuration such as this, it is made possible to store a plurality of kinds of ink in the one ink tank 15, and therefore, it is possible to provide an ink tank and a printing apparatus with good operability while further downsizing the printing apparatus 11.

### Other Embodiments

Embodiment(s) of the present invention can also be realized by a computer of a system or apparatus that reads out and executes computer executable instructions (e.g., one or more programs) recorded on a storage medium (which may also be referred to more fully as a 'non-transitory computer-readable storage medium') to perform the functions of one or more of the above-described embodiment(s) and/or that includes one or more circuits (e.g., application specific integrated circuit (ASIC)) for performing the functions of one or more of the above-described embodiment(s), and by a method performed by the computer of the system or apparatus by, for example, reading out and executing the computer executable instructions from the storage medium to perform the functions of one or more of the above-described embodiment(s) and/or controlling the one or more

circuits to perform the functions of one or more of the above-described embodiment(s). The computer may comprise one or more processors (e.g., central processing unit (CPU), micro processing unit (MPU)) and may include a network of separate computers or separate processors to read out and execute the computer executable instructions. The computer executable instructions may be provided to the computer, for example, from a network or the storage medium. The storage medium may include, for example, one or more of a hard disk, a random-access memory (RAM), a read only memory (ROM), a storage of distributed computing systems, an optical disk (such as a compact disc (CD), digital versatile disc (DVD), or Blu-ray Disc (BD)<sup>TM</sup>), a flash memory device, a memory card, and the like.

According to the printing apparatus of the present invention, it is possible to suppress ink from leaking out to the outside at the time of ink injection in a configuration in which an injection port is provided to an ink tank.

While the present invention has been described with reference to exemplary embodiments, it is to be understood that the invention is not limited to the disclosed exemplary embodiments. The scope of the following claims is to be accorded the broadest interpretation so as to encompass all such modifications and equivalent structures and functions.

This application claims the benefit of Japanese Patent Application No. 2015-214358, filed Oct. 30, 2015, which is hereby incorporated by reference wherein in its entirety.

What is claimed is:

1. A printing apparatus comprising:

a print head having an ejection port surface on which an ejection port which ejects a liquid is formed; and  
a liquid storage container including:

a liquid storage chamber configured to store the liquid to be supplied to the print head;

a liquid injection portion configured for injection of the liquid into the liquid storage chamber from the outside;

an atmosphere communication chamber configured to communicate with the atmosphere, the atmosphere communication chamber being arranged under the liquid storage chamber in a direction of gravity *in a state where the print head ejects liquid*; and

a communication flow path configured to allow communication between the liquid storage chamber and the atmosphere communication chamber, the communication flow path having an opening in the atmosphere communication chamber, the opening being arranged under the ejection port surface in the direction of gravity,

*wherein the atmosphere communication chamber being arranged under the liquid storage chamber in a direction of gravity in a state where the liquid is supplied to the liquid storage chamber.*

2. The printing apparatus according to claim 1, further comprising:

a liquid supply path that connects the liquid storage chamber and the print head;

a second valve provided on the liquid supply path and configured to switch a second open state in which the liquid is supplied to the print head from the liquid storage chamber and a second closed state in which the liquid is not supplied to the print head from the liquid storage chamber.

3. The printing apparatus according to claim 2,

wherein the second valve is in the second closed state when the liquid is injected into the liquid storage chamber from the liquid injection portion.

## 11

4. The printing apparatus according to claim 1, wherein the liquid storage container further includes an atmosphere communication flow path that is connected to the atmosphere communication chamber and an atmosphere opening that opens into the atmosphere, and  
5  
the printing apparatus further comprising a first valve provided on the atmosphere communication flow path and configured to switch a first open state in which the atmosphere communication chamber communicates with the atmosphere through the atmosphere opening and a first closed state in which the atmosphere communication chamber does not communicate with the atmosphere.
5. The printing apparatus according to claim 4, wherein the first valve is in the first closed state when the liquid is injected into the liquid storage chamber from the liquid injection portion.
6. The printing apparatus according to claim 4, wherein the atmosphere opening is arranged in the vicinity of a top of the liquid storage container.
7. The printing apparatus according to claim 1, wherein one end of the communication flow path is connected to a bottom surface side of the liquid storage chamber and the other end is connected to a bottom surface side of the atmosphere communication chamber.
8. The printing apparatus according to claim 1, wherein the liquid storage container is installed in the printing apparatus.
9. The printing apparatus according to claim 1, wherein the liquid storage chamber and the atmosphere communication chamber are formed by being defined by a partition wall arranged within the liquid storage container.
10. The printing apparatus according to claim 1, wherein the opening in the atmosphere communication chamber of the communication flow path is formed on a bottom surface side of the atmosphere communication chamber, and  
40  
a bottom surface of the atmosphere communication chamber is arranged so as to be under an ejection port surface on which an ejection port through which the liquid is ejected is formed in the print head.
11. The printing apparatus according to claim 1, wherein the storage container has a liquid supply portion from which the liquid in the liquid storage chamber is supplied to the print head, and  
45  
the liquid supply portion is located on a lower side of the liquid storage container.
12. The printing apparatus according to claim 11, wherein a bottom surface of the atmosphere communication chamber is arranged so as to be under the lowest position of a flow path that connects the liquid supply portion and the print head.
13. The printing apparatus according to claim 1, wherein a top surface of the atmosphere communication chamber is arranged under the ejection port surface in the direction of gravity.
14. The printing apparatus according to claim 1, wherein the liquid injection portion is arranged above the ejection port surface in the direction of gravity.
15. A liquid storage container comprising:  
60  
a liquid storage chamber configured to store a liquid to be supplied to a print head of the printing apparatus;  
65  
a liquid injection portion configured for injection of the liquid into the liquid storage chamber from the outside;

## 12

- an atmosphere communication chamber configured to communicate with the atmosphere, the atmosphere communication chamber being arranged under the liquid storage chamber in a direction of gravity *in a state where the print head ejects liquid*; and  
a communication flow path configured to allow communication between the liquid storage chamber and the atmosphere communication chamber, the communication flow path having an opening in the atmosphere communication chamber, the opening being arranged under an ejection port surface of the print head in the direction of gravity,  
*wherein the atmosphere communication chamber is arranged under the liquid storage chamber in a direction of gravity in a state where the liquid is supplied to the liquid storage chamber.*
16. A printing apparatus comprising:  
a print head having an ejection port surface on which an ejection port which ejects a liquid is formed;  
a liquid storage container including:  
a liquid storage chamber configured to store the liquid to be supplied to the print head;  
a liquid injection portion configured for injection of the liquid into the liquid storage chamber from the outside;  
an atmosphere communication chamber configured to communicate with the atmosphere, the atmosphere communication chamber being arranged under the liquid storage chamber in a direction of gravity;  
a communication flow path having an opening in the atmosphere communication chamber and configured to allow communication between the liquid storage chamber and the atmosphere communication chamber, the opening being arranged under the ejection port surface in the direction of gravity; and  
an atmosphere communication flow path that is connected to the atmosphere communication chamber and an atmosphere opening that opens into the atmosphere; and  
wherein the printing apparatus further comprises a first valve provided on the atmosphere communication flow path and configured to switch a first open state in which the atmosphere communication chamber communicates with the atmosphere through the atmosphere opening and a first closed state in which the atmosphere communication chamber does not communicate with the atmosphere.
17. The printing apparatus according to claim 16, wherein the first valve is in the first closed state when the liquid is injected into the liquid storage chamber from the liquid injection portion.
18. The printing apparatus according to claim 16, further comprising:  
55  
a liquid supply path that connects the liquid storage chamber and the print head;  
a second valve provided on the liquid supply path and configured to switch a second open state in which the liquid is supplied to the print head from the liquid storage chamber and a second closed state in which the liquid is not supplied to the print head from the liquid storage chamber.
19. The printing apparatus according to claim 18, wherein the second valve is in the second closed state when the liquid is injected into the liquid storage chamber from the liquid injection portion.

## 13

20. The printing apparatus according to claim 16, wherein one end of the communication flow path is connected to a bottom surface side of the liquid storage chamber and the other end is connected to a bottom surface side of the atmosphere communication chamber. 5
21. The printing apparatus according to claim 16, wherein the liquid storage container is installed in the printing apparatus.
22. The printing apparatus according to claim 16, wherein the storage container has a liquid supply portion from which the liquid in the liquid storage chamber is supplied to the print head, and the liquid supply portion is located on a lower side of the liquid storage container. 15
23. The printing apparatus according to claim 16, wherein a top surface of the atmosphere communication chamber is arranged under the ejection port surface in the direction of gravity. 20
24. The printing apparatus according to claim 16, wherein the liquid injection portion is arranged above the ejection port surface in the direction of gravity.
25. *The printing apparatus according to claim 1, wherein a liquid surface at which a gas-liquid exchange between liquid in the communication flow path and atmosphere in the atmosphere communication chamber is performed is below the ejection port surface in the direction of gravity.* 25
26. *A printing apparatus comprising:*  
*a print head having an ejection port surface on which an ejection port which ejects a liquid is formed; and* 30  
*a liquid storage container including:*  
*a liquid storage chamber configured to store the liquid to be supplied to the print head;*  
*a liquid injection portion configured for injection of the liquid into the liquid storage chamber from the outside;* 35  
*an atmosphere communication chamber configured to communicate with the atmosphere, a top surface of the atmosphere communication chamber being arranged below the ejection port surface in a direction of gravity in a state where the print head ejects liquid; and* 40  
*a communication flow path configured to allow communication between the liquid storage chamber and the atmosphere communication chamber,* 45  
*wherein a liquid surface at which a gas-liquid exchange between the liquid in the communication flow path and the atmosphere in the atmosphere communication chamber is performed is below the ejection port surface in the direction of gravity, and* 50  
*wherein the atmosphere communication chamber is arranged under the liquid storage chamber in a direction of gravity in a state where the liquid is supplied to the liquid storage chamber.* 55
27. *A printing apparatus comprising:*  
*a print head having an ejection port surface on which an ejection port which ejects a liquid is formed; and*  
*a liquid storage container including:*  
*a liquid storage chamber configured to store the liquid to be supplied to the print head;* 60  
*a liquid injection portion configured for injection of the liquid into the liquid storage chamber from the outside;*  
*an atmosphere communication chamber configured to communicate with the atmosphere, a large part of the atmosphere communication chamber being* 65

## 14

- arranged under the liquid storage chamber in a direction of gravity in a state where the print head ejects liquid; and*  
*a communication flow path configured to allow communication between the liquid storage chamber and the atmosphere communication chamber,*  
*wherein a liquid surface at which a gas-liquid exchange between the liquid in the communication flow path and the atmosphere in the atmosphere communication chamber is performed is below the ejection port surface in the direction of gravity, and*  
*wherein the atmosphere communication chamber is arranged under the liquid storage chamber in a direction of gravity in a state where the liquid is supplied to the liquid storage chamber.*
28. *The printing apparatus according to claim 27, wherein a majority of the atmosphere communication chamber is arranged under the liquid storage chamber in the direction of gravity.* 20
29. *A printing apparatus comprising:*  
*a print head having an ejection port surface on which an ejection port which ejects a liquid is formed; and*  
*a liquid storage container including:*  
*a liquid storage chamber configured to store the liquid to be supplied to the print head;*  
*a liquid injection portion configured for injection of the liquid into the liquid storage chamber from the outside;*  
*an atmosphere communication chamber configured to communicate with the atmosphere, a large part of the atmosphere communication chamber being arranged under the liquid storage chamber in a direction of gravity; and*  
*a communication flow path configured to allow communication between the liquid storage chamber and the atmosphere communication chamber; and*  
*a liquid flow path for supplying the liquid stored in the liquid storage chamber to the print head,*  
*wherein a liquid surface at which a gas-liquid exchange between the liquid in the communication flow path and the atmosphere in the atmosphere communication chamber is performed is below the ejection port surface in a direction of gravity,*  
*wherein a position where the liquid flow path is connected to the liquid storage chamber is above the liquid surface in the direction of gravity, and*  
*wherein the atmosphere communication chamber is arranged under the liquid storage chamber in a direction of gravity in a state where the liquid is supplied to the liquid storage chamber.*
30. *The printing apparatus according to claim 26, further comprising:*  
*a valve provided on a flow path from the liquid injection portion to the print head and capable of blocking the flow path.*
31. *The printing apparatus according to claim 30, further comprising:*  
*a supply path for supplying the liquid stored in the liquid storage chamber to the print head,*  
*wherein the valve is provided on the supply path.*
32. *The printing apparatus according to claim 30, wherein the valve blocks the flow path in a state where the liquid is injected from the liquid injection portion.*
33. *The printing apparatus according to claim 26, wherein the liquid surface is horizontal in a state where the print head ejects the liquid.*

34. The printing apparatus according to claim 27, further comprising:

a valve provided on a flow path from the liquid injection portion to the print head and capable of blocking the flow path. 5

35. The printing apparatus according to claim 34, further comprising:

a supply path for supplying the liquid stored in the liquid storage chamber to the print head, wherein the valve is provided on the supply path. 10

36. The printing apparatus according to claim 34, wherein the valve blocks the flow path in a state where the liquid is injected from the liquid injection portion.

37. The printing apparatus according to claim 27, wherein the liquid surface is parallel to a horizontal direction in a state where the print head ejects the liquid. 15

38. The printing apparatus according to claim 29, further comprising:

a valve provided on the liquid flow path to the print head and capable of blocking the liquid flow path. 20

39. The printing apparatus according to claim 38, wherein the valve blocks the liquid flow path in a state where the liquid is injected from the liquid injection portion.

40. The printing apparatus according to claim 29, wherein the liquid surface is parallel to a horizontal direction in a state where the print head ejects the liquid. 25

\* \* \* \* \*