

US00RE49263E

(19) **United States**
 (12) **Reissued Patent**
Han et al.

(10) **Patent Number: US RE49,263 E**
 (45) **Date of Reissued Patent: Oct. 25, 2022**

(54) **METHOD AND APPARATUS FOR TRANSMITTING CONTROL INFORMATION IN A WIRELESS COMMUNICATION SYSTEM**

(71) Applicant: **LG ELECTRONICS INC.**, Seoul (KR)

(72) Inventors: **Seung Hee Han**, Anyang-si (KR); **Jae Hoon Chung**, Anyang-si (KR); **Sung Ho Moon**, Anyang-si (KR); **Moon Il Lee**, Anyang-si (KR)

(73) Assignee: **LG Electronics Inc.**, Seoul (KR)

(21) Appl. No.: **15/476,254**

(22) Filed: **Mar. 31, 2017**

Related U.S. Patent Documents

Reissue of:

(64) Patent No.: **8,995,384**
 Issued: **Mar. 31, 2015**
 Appl. No.: **14/266,019**
 Filed: **Apr. 30, 2014**

U.S. Applications:

(63) Continuation of application No. 13/521,710, filed as application No. PCT/KR2011/000286 on Jan. 14, 2011, now Pat. No. 8,767,661.

(60) Provisional application No. 61/311,740, filed on Mar. 8, 2010, provisional application No. 61/301,160, filed on Feb. 3, 2010, provisional application No. 61/298,550, filed on Jan. 27, 2010, provisional application No. 61/295,741, filed on Jan. 17, 2010.

(30) **Foreign Application Priority Data**

Dec. 16, 2010 (KR) 10-2010-0129072

(51) **Int. Cl.**

H04W 4/00 (2018.01)
H04L 5/00 (2006.01)
H04W 72/04 (2009.01)
H04W 72/02 (2009.01)
H04J 11/00 (2006.01)
H04L 27/26 (2006.01)

(52) **U.S. Cl.**

CPC **H04W 72/0413** (2013.01); **H04J 11/0069** (2013.01); **H04L 5/001** (2013.01); **H04L 5/0026** (2013.01); **H04L 5/0053** (2013.01); **H04L 5/0055** (2013.01); **H04L 5/0094** (2013.01); **H04L 27/2602** (2013.01); **H04L 27/2636** (2013.01); **H04L 27/2697** (2013.01); **H04W 72/02** (2013.01); **H04W 4/00** (2013.01)

(58) **Field of Classification Search**

CPC . **H04L 27/2636**; **H04L 27/2697**; **H04L 5/001**; **H04L 5/0026**; **H04L 5/0055**; **H04L 5/0094**; **H04W 72/0413**; **H04W 72/02**
 USPC 370/329
 See application file for complete search history.

(56) **References Cited**

U.S. PATENT DOCUMENTS

2007/0041404 A1* 2/2007 Palanki H04B 1/692
 370/479
 2008/0075060 A1* 3/2008 Tirola H04L 5/0016
 370/344
 2008/0080467 A1* 4/2008 Pajukoski H04B 1/7103
 370/342
 2008/0090528 A1 4/2008 Malladi
 2008/0095106 A1 4/2008 Malladi et al. H04L 5/0057
 370/329
 2008/0298502 A1* 12/2008 Xu H04L 5/0055
 375/299
 2008/0310547 A1* 12/2008 Tirola H04L 27/2615
 375/296
 2009/0129259 A1 5/2009 Malladi et al. H04B 7/0417
 370/210
 2009/0196366 A1 8/2009 Shen et al.
 2009/0245284 A1 10/2009 Xu et al.

(Continued)

FOREIGN PATENT DOCUMENTS

CN 101558678 A 10/2009
 CN 101617489 A 12/2009

(Continued)

OTHER PUBLICATIONS

R1-091204, XP050338819: 3GPP TSF RAN WG1 #56bis, Seoul Korea, Mar. 23-27, 2009, "UL Control channel design to support carrier aggregation," LG Electronics, pp. 1-6.

R1-093942, XP050388442: 3GPP TSG-RAN WG1 Meeting #58bis, Oct. 12-16, 2009, Miyazaki, Japan, Panasonic, "UL ACK/NACK transmission on PUCCH for carrier aggregation pp. 1-4.

XP031600105: "Performance Comparison Between Cyclic Shift and Block Spreading CDMA Using MLD with Channel Coding Information for Uplink Control Signals;" Department of Information Network Engineering, Tokyo City University, Takahashi, et al., 2009, pp. 1-5.

(Continued)

Primary Examiner — Nick Corsaro

(74) *Attorney, Agent, or Firm* — Dentons US LLP

(57) **ABSTRACT**

The present invention relates to a wireless communication system. More specifically, the present invention relates to a method for transmitting control signal via a PUCCH in a wireless communication system, and to an apparatus for the method, wherein the method comprises the following steps: joint-coding a plurality of pieces of control information to obtain a single codeword; obtaining a first modulation symbol sequence from the single codeword; obtaining, from the first modulation symbol sequence, a plurality of second modulation symbol sequences corresponding to each slot in the PUCCH; cyclically shifting the plurality of second modulation symbol sequences in a time domain to obtain a plurality of third modulation symbol sequences; performing a discrete Fourier transform (DFT) precoding process on the plurality of third modulation symbol sequences to obtain a plurality of complex symbol sequences in a frequency domain; and transmitting the plurality of complex symbol sequences via the PUCCH.

22 Claims, 59 Drawing Sheets

(56)

References Cited

U.S. PATENT DOCUMENTS

2010/0098012 A1 4/2010 Bala et al.
 2011/0110246 A1 5/2011 Damnjanovic et al.
 2011/0243066 A1 10/2011 Nayeb Nazar et al.
 2011/0280203 A1 11/2011 Han et al.
 2012/0014320 A1 1/2012 Nam et al.
 2012/0300726 A1* 11/2012 Han et al. 370/329

FOREIGN PATENT DOCUMENTS

KR 10-2008-0076131 A 8/2008
 KR 10-2009-0099500 A 9/2009
 KR 10-2009-0111271 A 10/2009
 KR 1020100002114 A 1/2010

OTHER PUBLICATIONS

R1-080138, XP050108669: 3GPP TSG RAN WG1, Meeting #51bis, Sevilla, Spain, Jan. 14-18, 2008, Panasonic, Samsung "Way Forward on the Cyclic shift Hopping for PUCCH," pp. 1-2.
 XP002558928: LTE Phy Spec. Samsung Electronics Jun. 24, 2008, pp. 1-77.
 XP002723008: 3GPP TS 36.211 V9.0.0, Release 9, 5.4 Physical uplink control channel, (Dec. 2009) pp. 1-5.
 Office Action of European Patent Office in Appl'n No. 11733101.7, dated Jan. 30, 2018.
 Notice of Allowance of the Korean Patent Office in Appl'n No. 10-2017-0050546, dated Jan. 25, 2018.
 Notice of Allowance of Korean Patent Office in Appl'n No. 10-2010-0129072, dated Jan. 19, 2017.
 Reissue of U.S. Pat. No. 8,995,384.
 Continuation of U.S. Pat. No. 8,767,661.
 Ryota Takahashi, et al., Performance comparison between cyclic shift and block spreading CDMA using MLD with channel coding information for uplink control signals, Vehicular Technology conference fall (VTC 2009-Fall), 2009 IEEE 70th, Sep. 20, 2009, pp. 1-5.

3GPP TS 36.211 V8.5.0 (Dec. 2008).

Ericsson et al.: "A/N transmission in the uplink for carrier aggregation", 3GPP Draft; R1-100044, 3rd Generation Partnership Project (3GPP), Mobile Competence Centre; 650, Route Des Lucioles; F-06921 Sophia-Antipolis Cedex; France, vol. RAN WG1, no. Valencia, Spain; 20100118, Jan. 15, 2010, XP050418357.

Nokia Siemens Networks et al.: "Multiplexing capability of CQIs and ACK/NACKs from different UEs", 3GPP Draft; R1-072315, 3rd Generation Partnership Project (3GPP), Mobile Competence Centre 650, Route Des Lucioles; F-06921 Sophia-Antipolis Cedex; France, vol. RAN WG1, no. Kobe, Japan 20070502, May 2, 2007, XP050106045.

NTT Docomo et al.: "on PUCCH structure for CQI Report", 3GPP Draft; R1-074812 On Pucch Structure for CQI Report, 3rd Generation Partnership Project (3GPP), Mobile Competence Centre; 650, Route Des Lucioles; F-06921 Sophia-Antipolis Cedex; France, vol. RAN WG1, no. Korea; 20071030, Oct. 30, 2007, XP050108276.
 Ericsson: "On multiple ACK/NACK for LTE TDD", 3GPP Draft; R1-0082001, 3rd Generation Partnership Project (3GPP), Mobile Competence Centre; 650, Route Des Lucioles; F-06921 Sophia-Antipolis Cedex; France, vol. RAN WG1, no. Kansas City, USA; 20080514, May 14, 2008, XP050110348.

Huawei: "PUCCH design for carrier aggregation", 3GPP Draft; R1-093838, 3rd Generation Partnership Project (3GPP), Mobile Competence Centre; 650, Route Des Lucioles; F-06921 Sophia-Antipolis Cedex; France, no. Miyazaki; 20091012, Oct. 12, 2009, XP050388345.

Anonymous: "LTE; Evolved Universal Terrestrial Radio Access (E-UTRA); Multiplexing and channel coding (3GPP TS 36.212 version 9.0.0 Release 9)", ETSI TS 136 212, Jan. 12, 2010, pp. 37-37, France.

Farooq Khan: "LTE for 4G Mobile Broadband", Mar. 1, 2009, Cambridge University Press, UK, pp. 342-367.

Qualcomm, NTT DoCoMo, CATT, CATR, "Description of PUSCH-like PUCCH format with CDM", 3GPP TSG RAN WG1 #82bis, Oct. 5-9, 2015, R1-156308.

* cited by examiner

FIG. 1
PRIOR ART

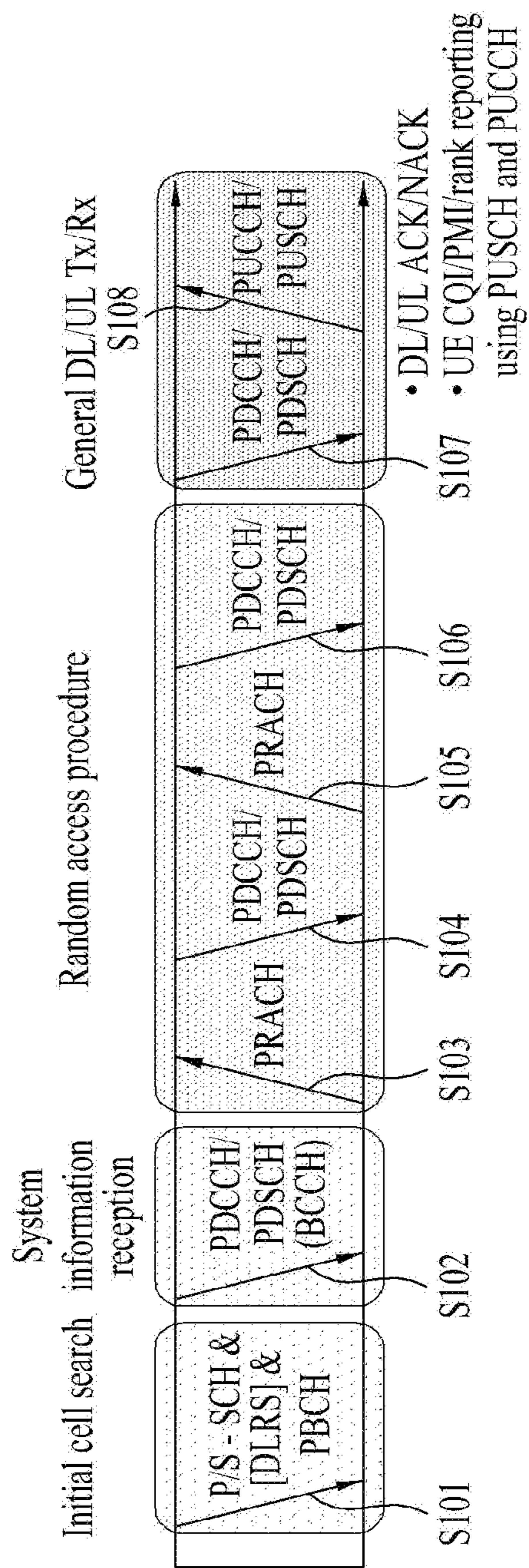

Amended

FIG. 2
PRIOR ART

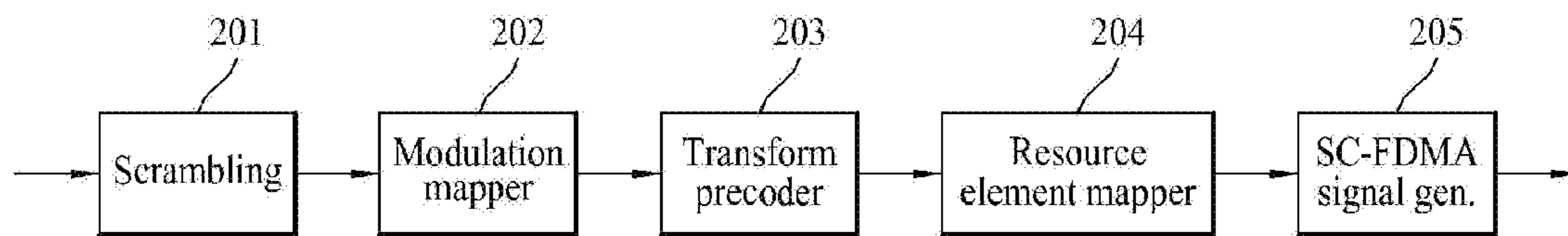

Amended

FIG. 3
PRIOR ART

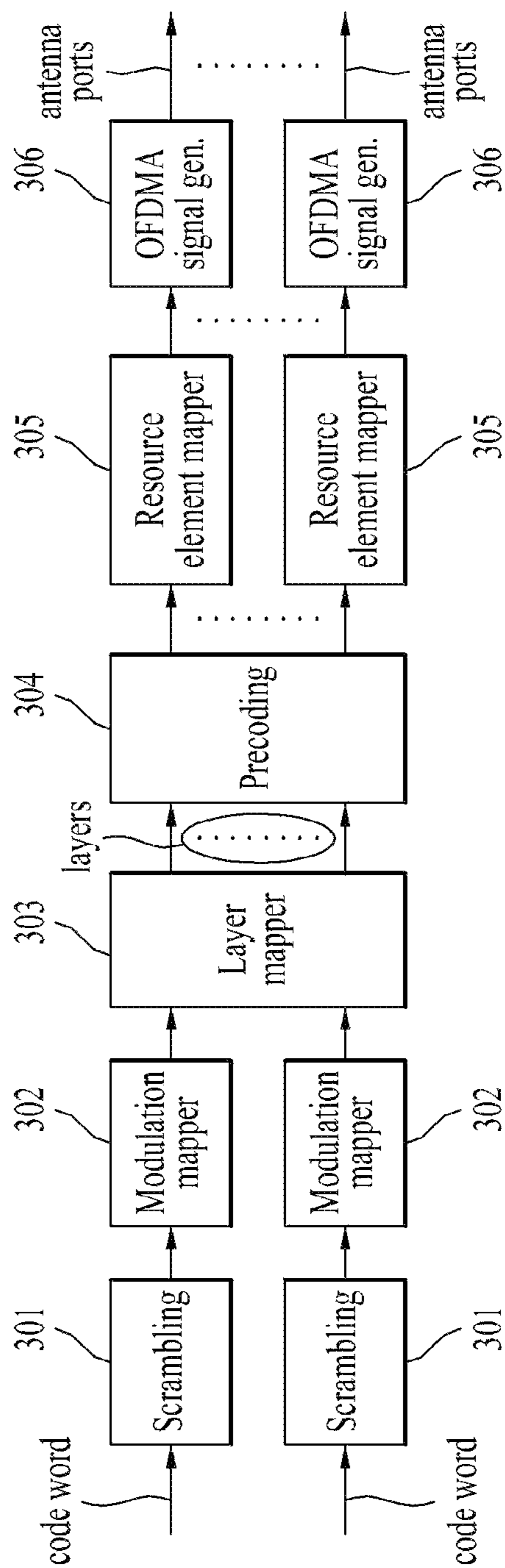

Amended

FIG. 4
PRIOR ART

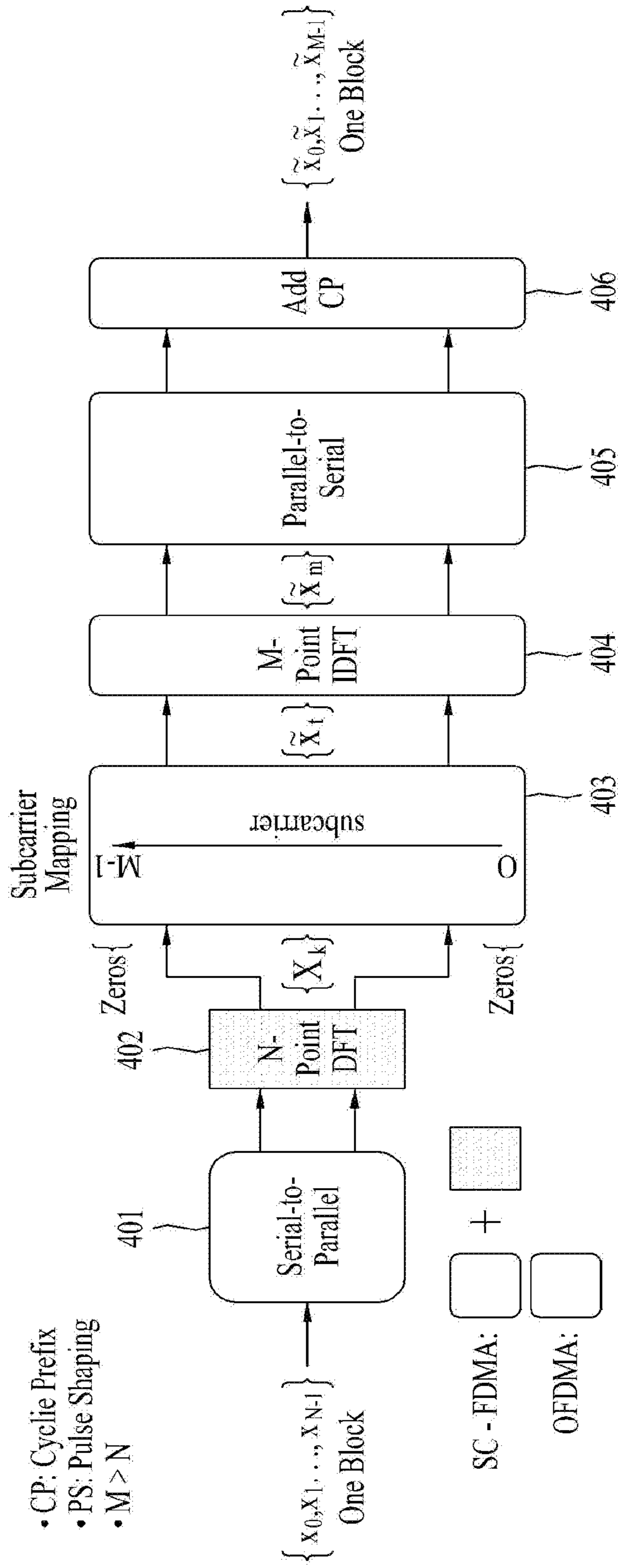

Amended

FIG. 5
PRIOR ART

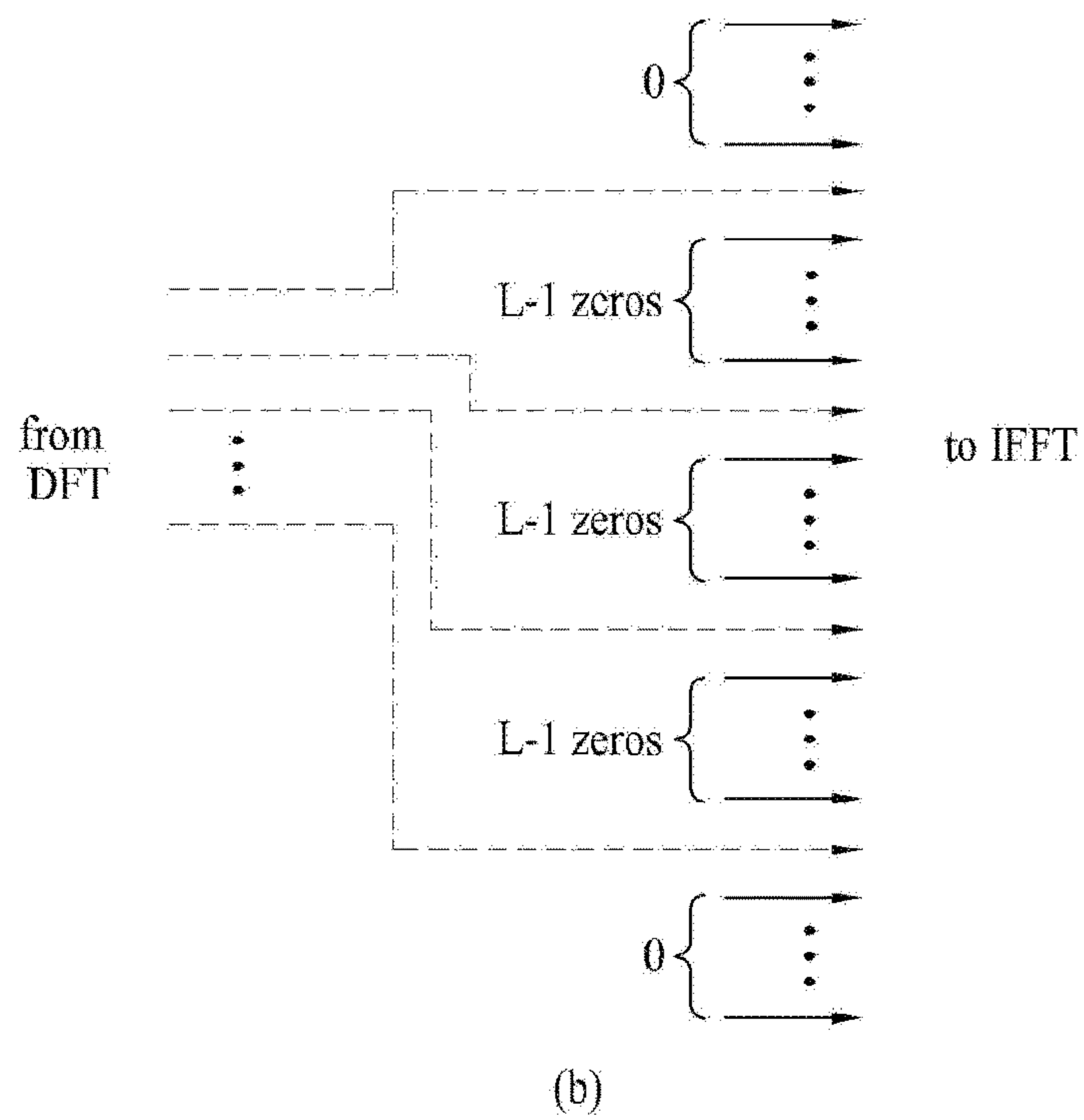
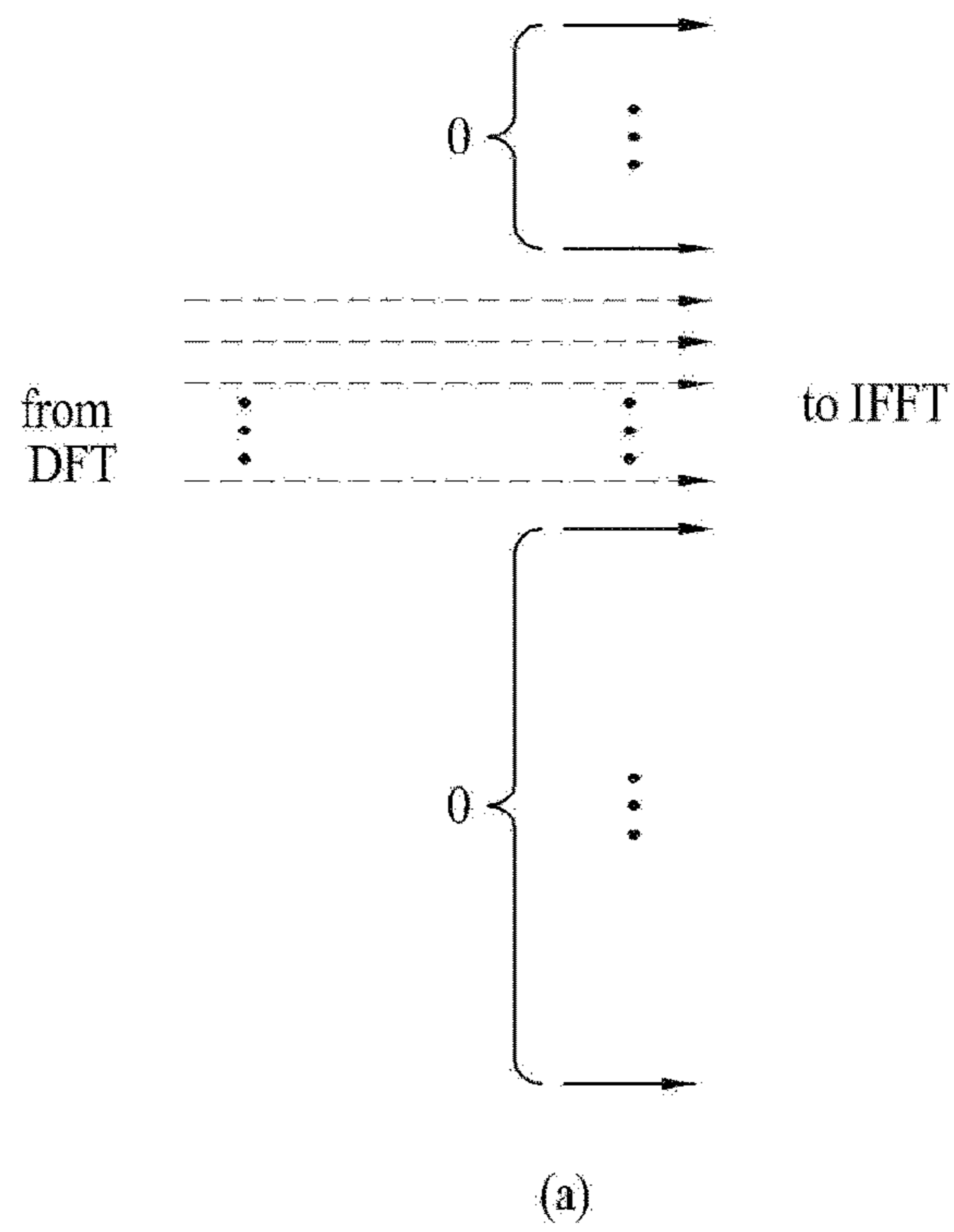
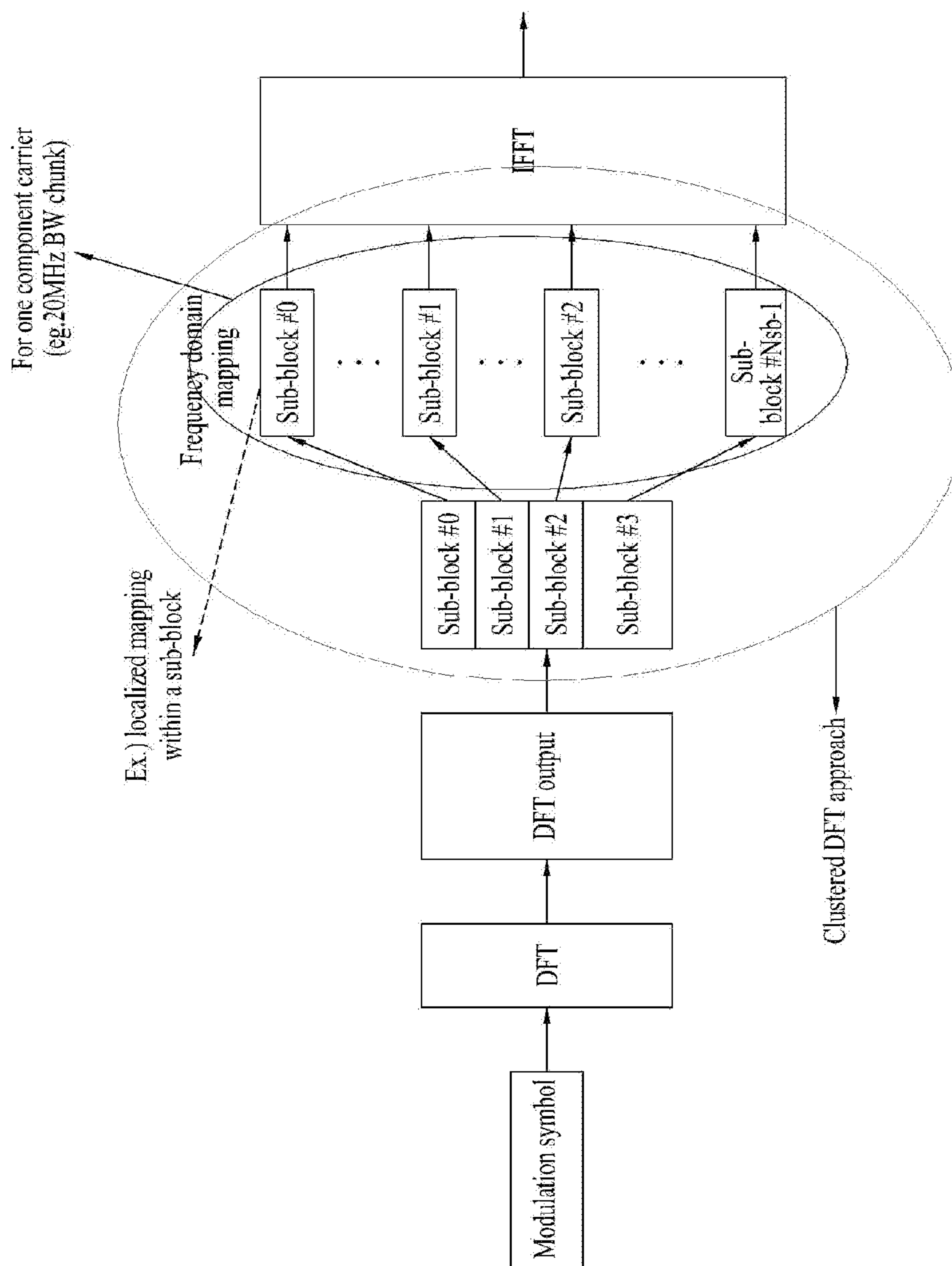

FIG. 6
PRIOR ART



Amended

FIG. 7
PRIOR ART

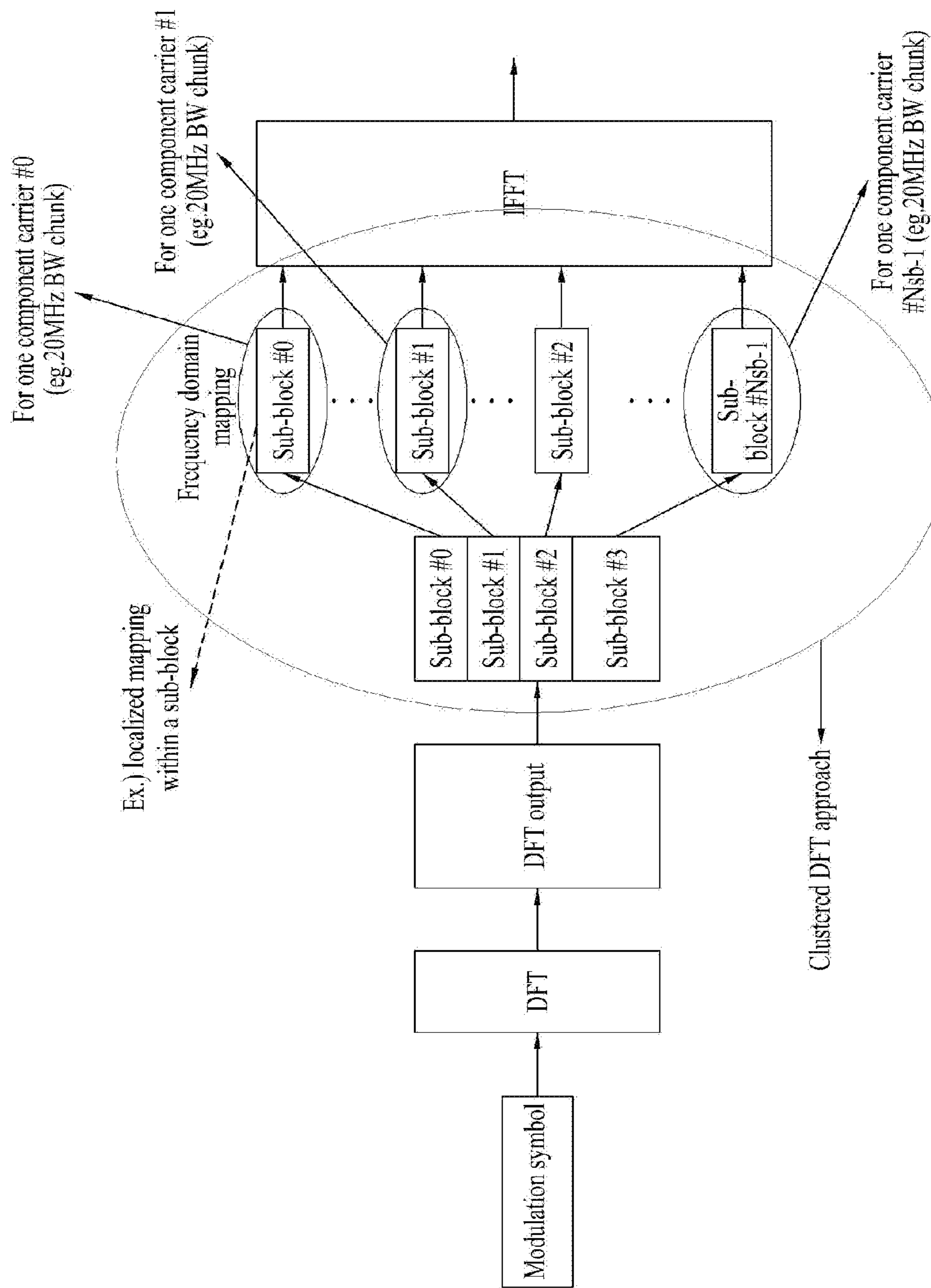

FIG. 8
PRIOR ART

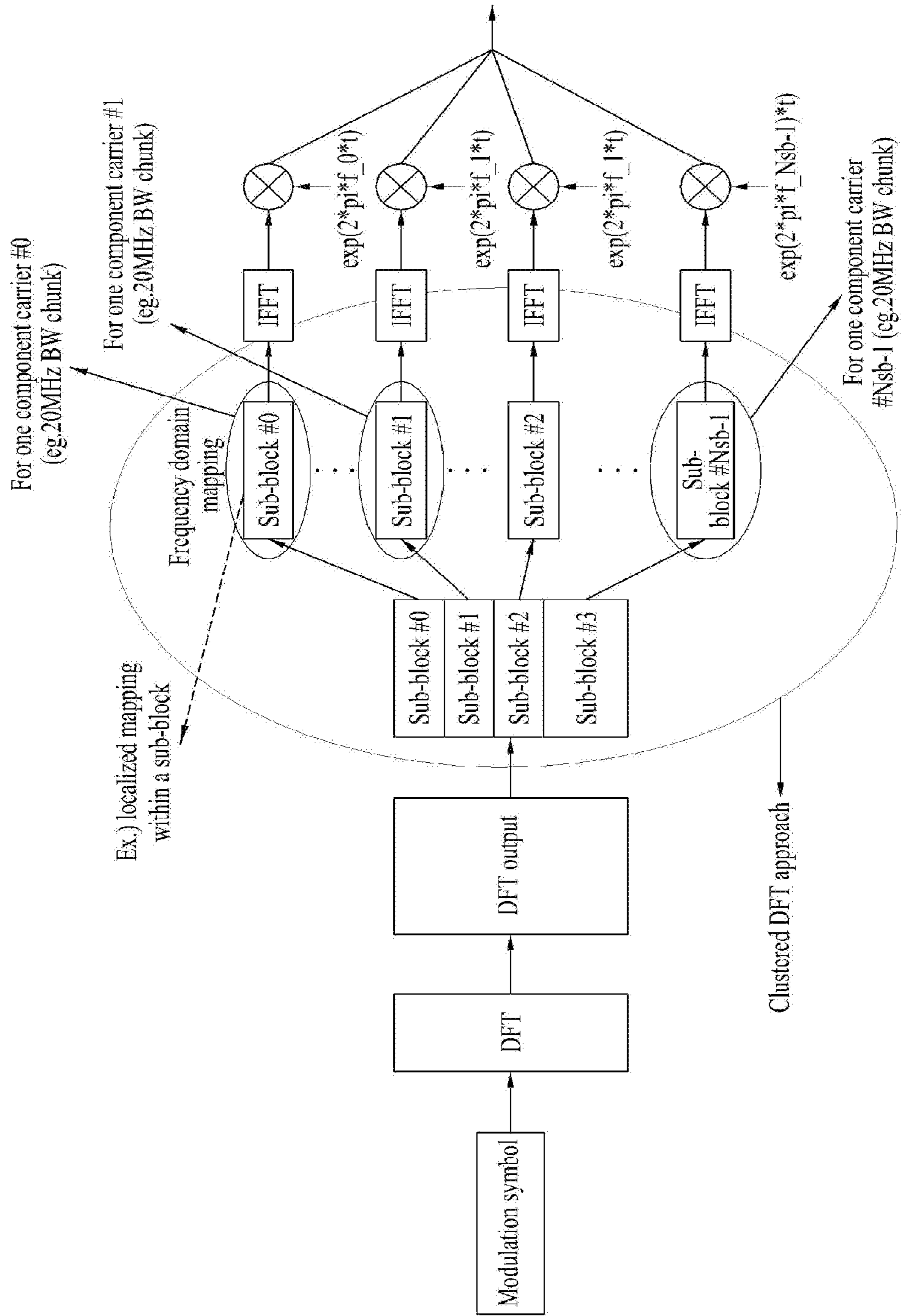

FIG. 9
PRIOR ART

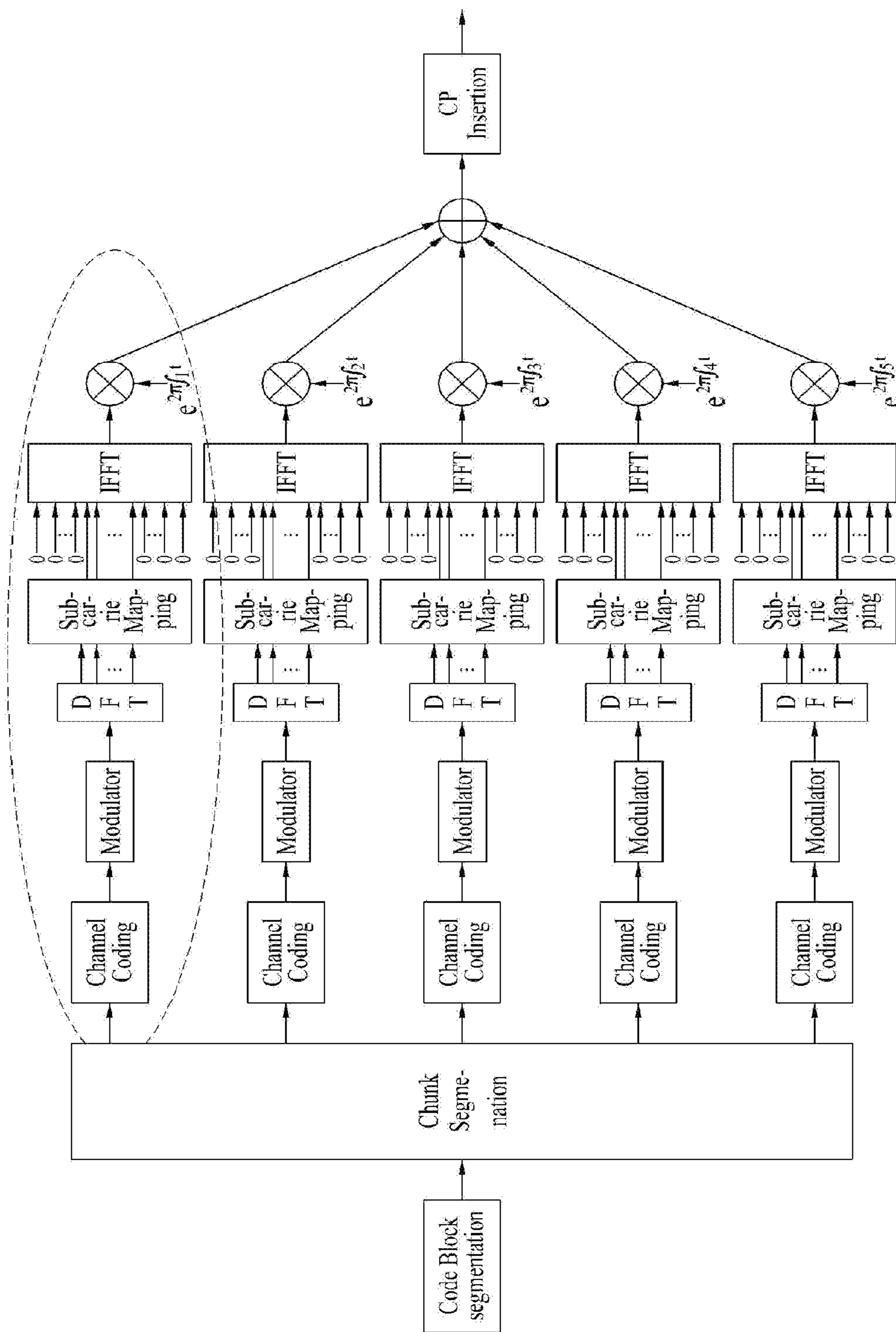

FIG. 10
PRIOR ART

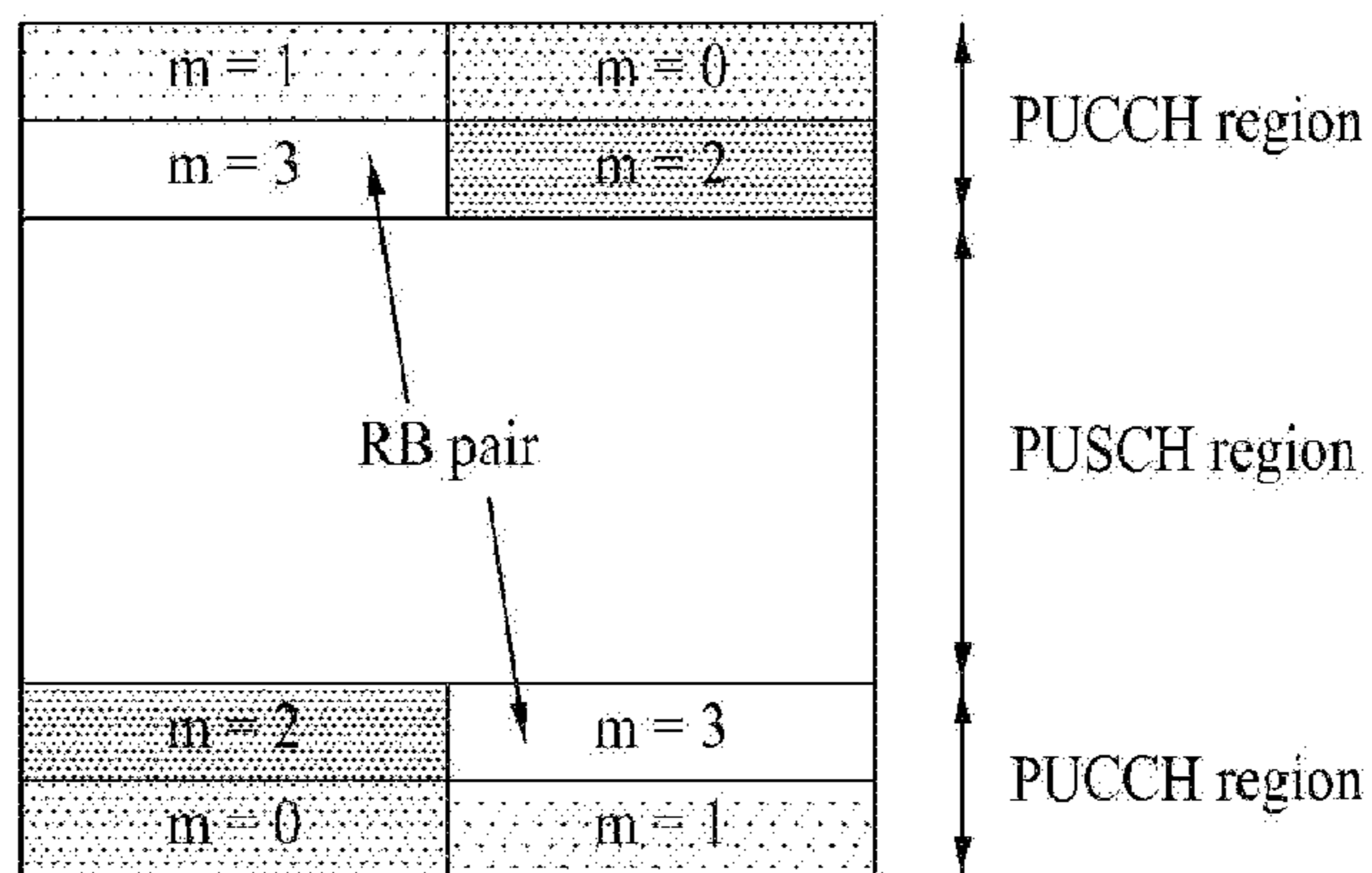

FIG. 11
PRIOR ART

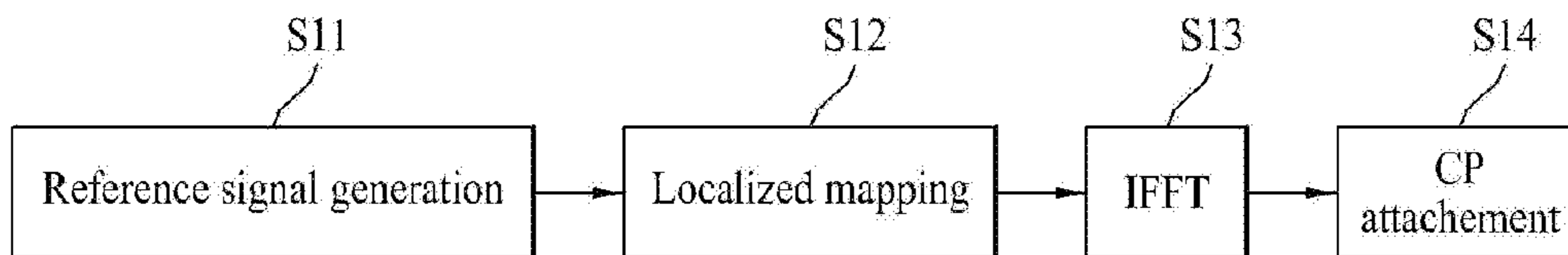

FIG. 12A
PRIOR ART

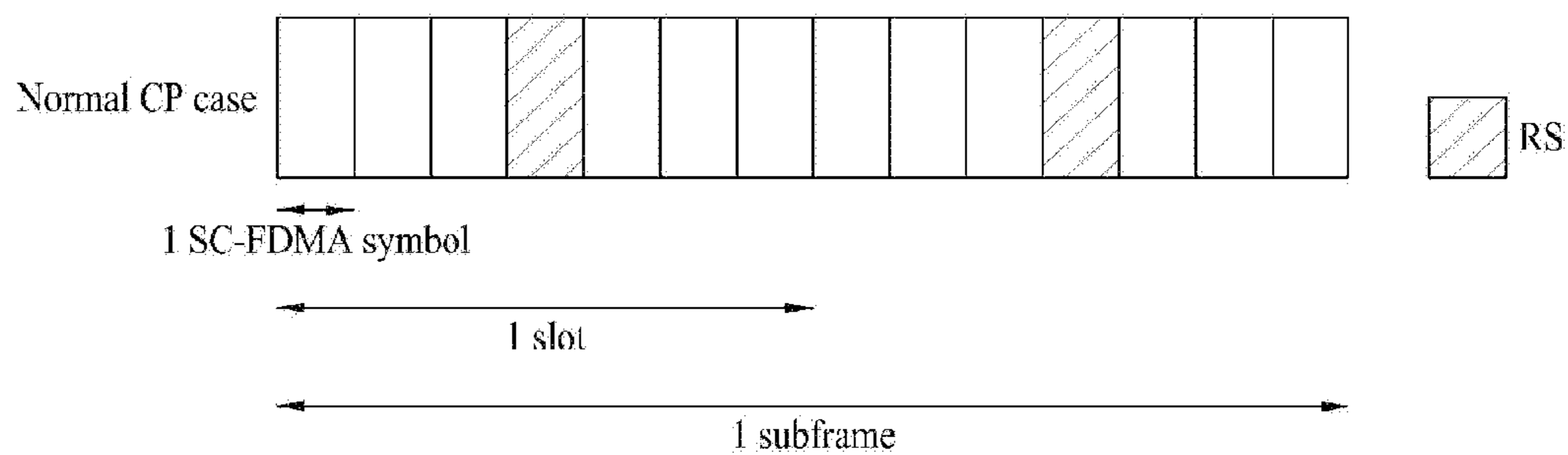
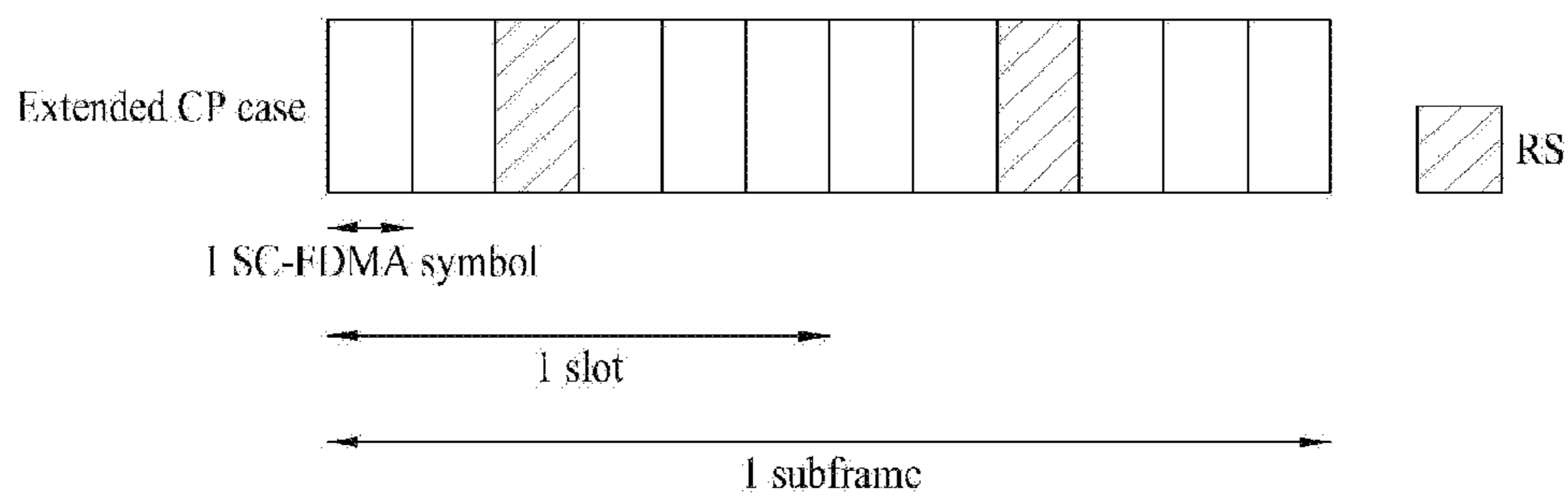
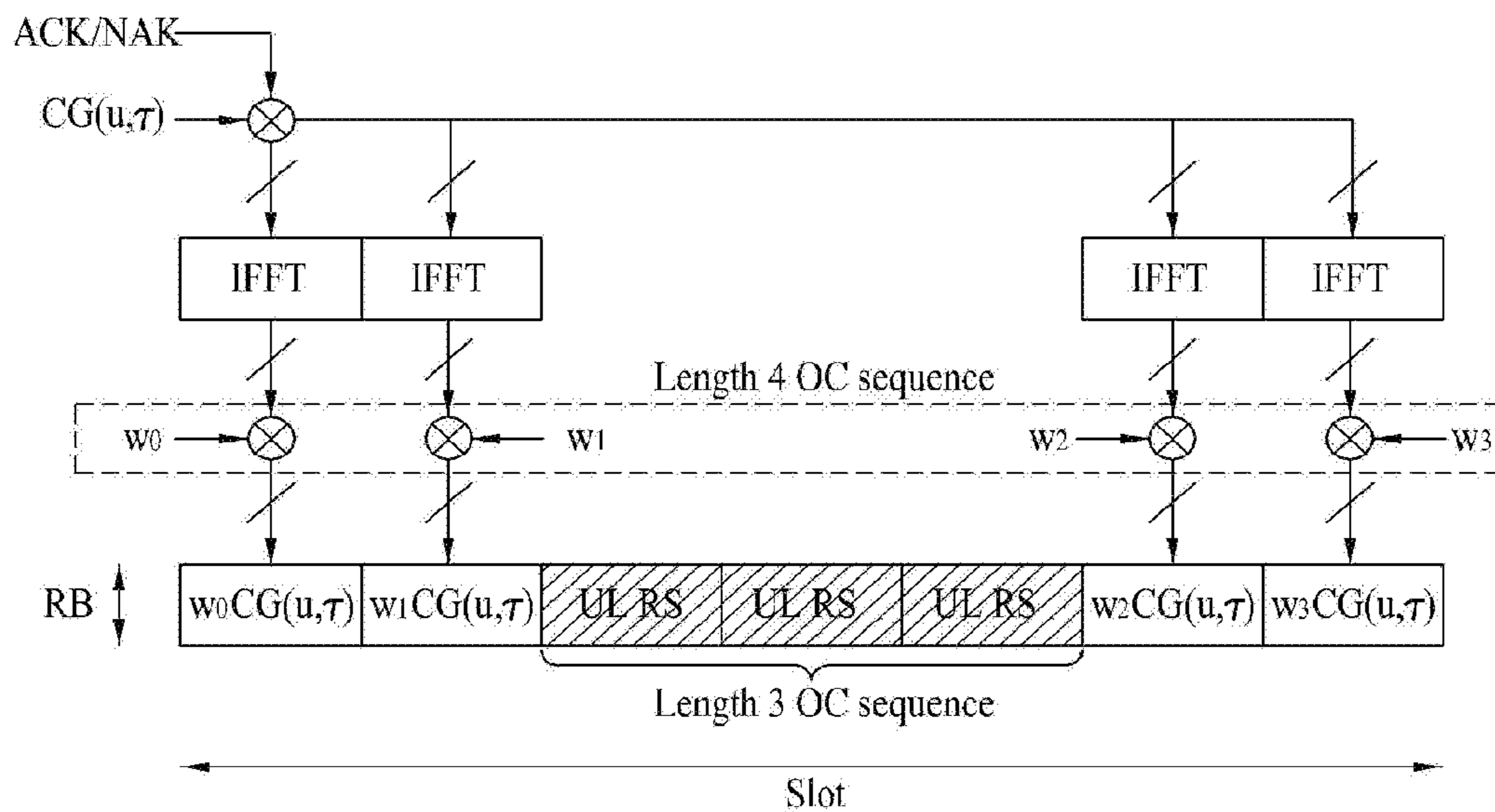

FIG. 12B
PRIOR ART



Amended

FIG. 13
PRIOR ART



PUCCH format 1a and 1b structure (normal CP case)

FIG. 14
PRIOR ART

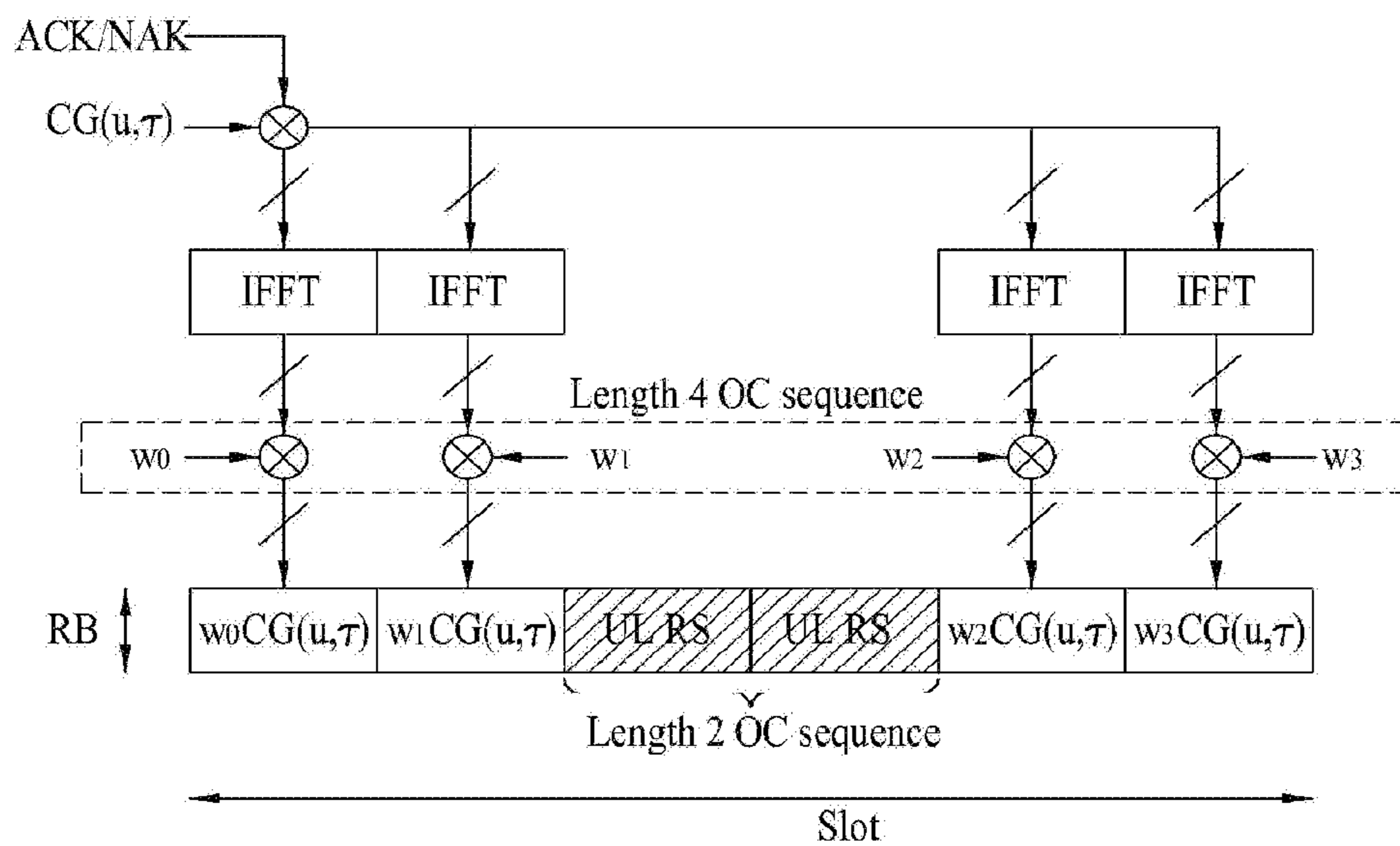

PUCCH format 1a and 1b structure (extended CP case)

Amended

FIG. 15
PRIOR ART

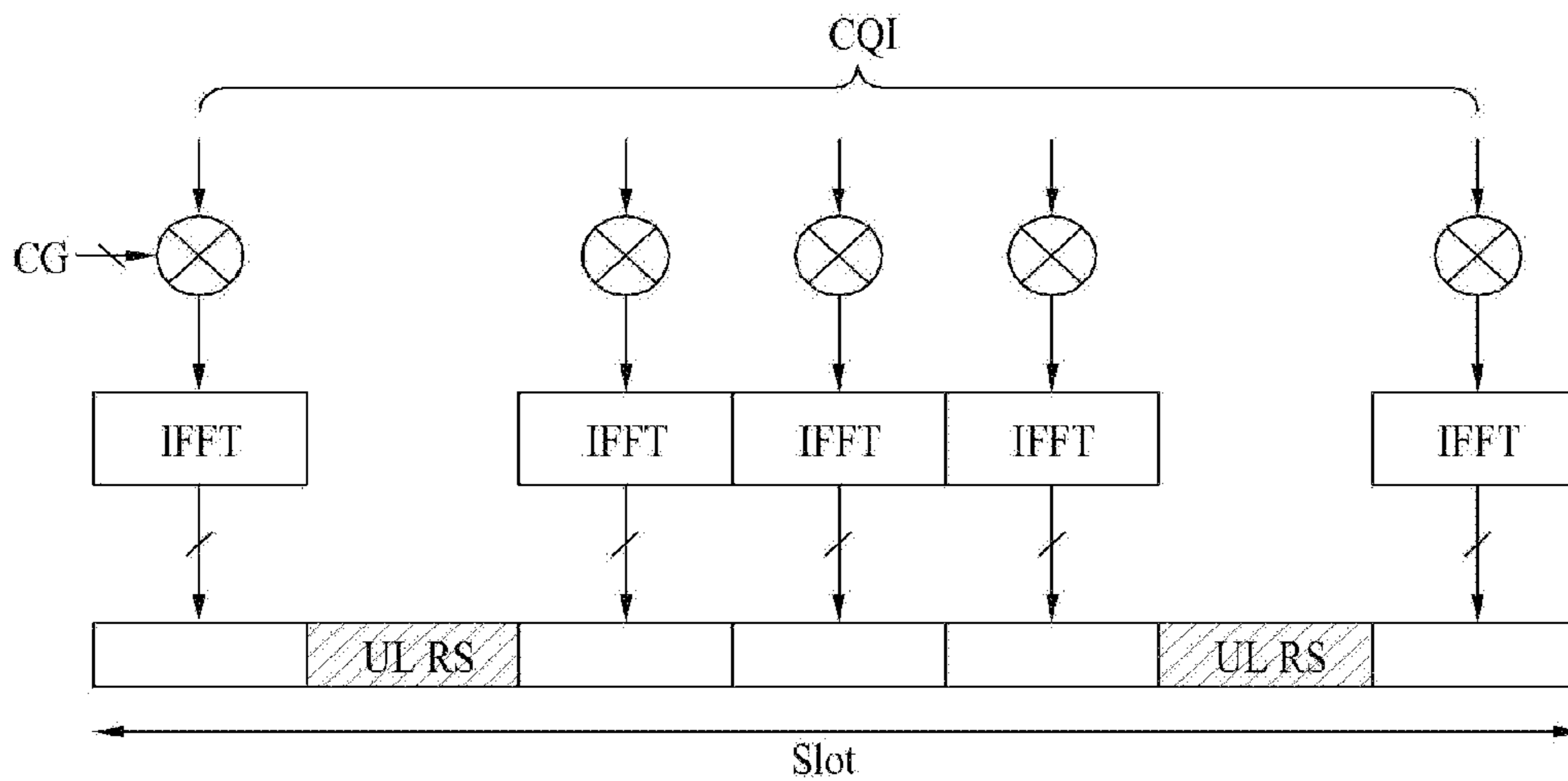

PUCCH format 2,2a and 2b structure (normal CP case)

FIG. 16
PRIOR ART

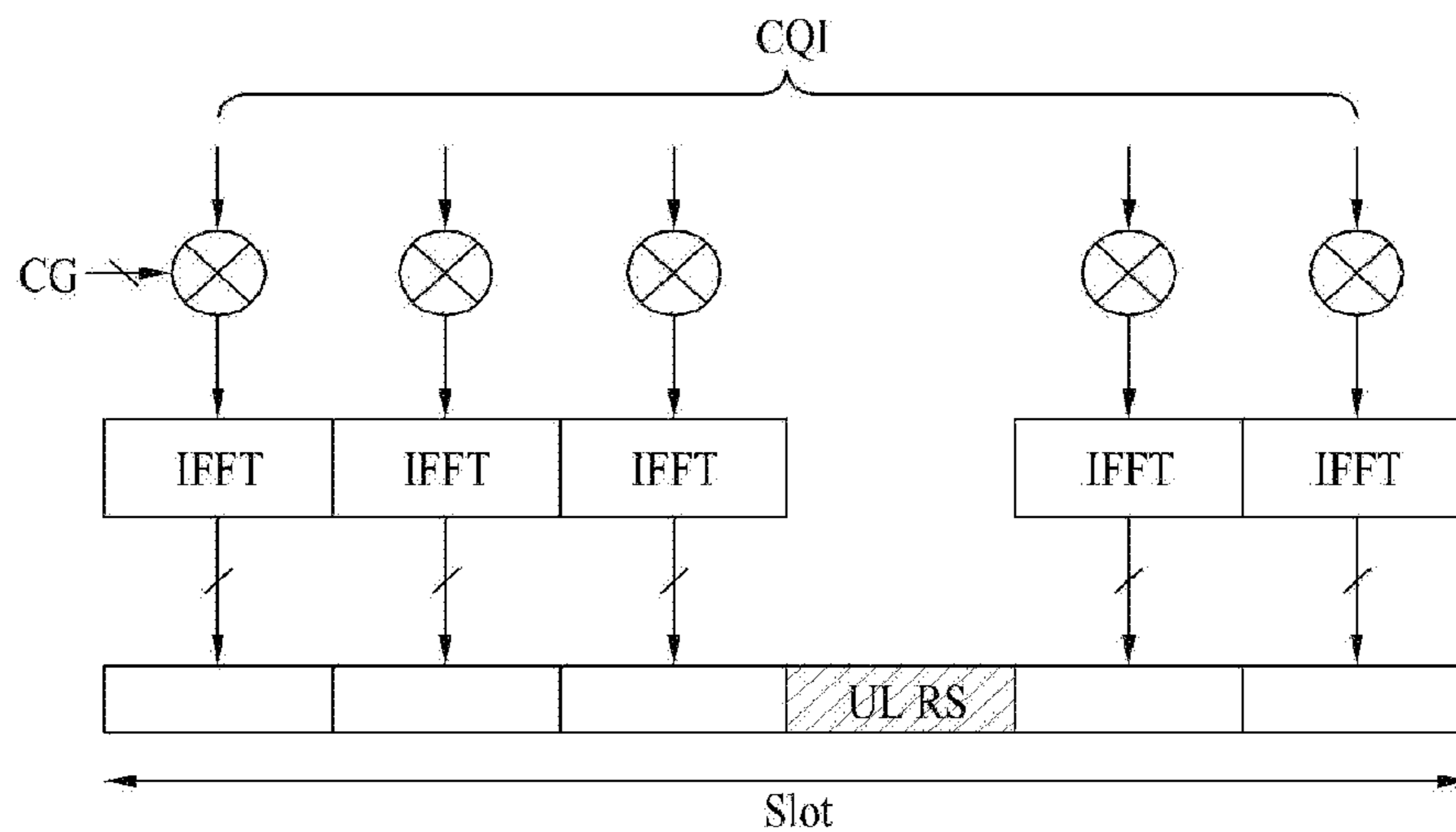

PUCCH format 2,2a and 2b structure (extended CP case)

FIG. 17
PRIOR ART

Resource allocation: 18 ACK/NACK channels with normal CP $\Delta_{\text{shift}} = \frac{\text{PUCCH}}{\text{shift}} = 2$

Cell specific cyclic shift offset		RS orthogonal cover		ACK/NACK orthogonal cover	
$\delta_{\text{offset}}^{\text{PUCCH}} = 1$	$\delta_{\text{offset}}^{\text{PUCCH}} = 0$	$\bar{n}_{\text{OC}} = 0$	$\bar{n}_{\text{OC}} = 1$	$n_{\text{OC}} = 0$	$n_{\text{OC}} = 1$
$n_{\text{CS}} = 1$	$n_{\text{CS}} = 0$	$n' = 0$			
2	1	6		6	
3	2	1		7	
4	3			8	
5	4	2		9	
6	5			10	
7	6	3		11	
8	7			12	
9	8	4		13	
10	9			14	
11	10	5		15	
0	11			16	
				17	

$\Delta_{\text{shift}}^{\text{PUCCH}} \in \{1, 2, 3\}$ for normal cyclic prefix
 $\Delta_{\text{shift}}^{\text{PUCCH}} \in \{1, 2, 3\}$ for extended cyclic prefix

$\delta_{\text{offset}}^{\text{PUCCH}} \in \{0, 1, \dots, \Delta_{\text{shift}}^{\text{PUCCH}} - 1\}$ Cell specific cyclic shift offset

n_{OC} Orthogonal sequence index for ACK/NACK
 \bar{n}_{OC} Orthogonal sequence index for RS
 n_{CS} Cyclic shift value of a CAZAC sequence
 n' ACK/NACK resource index used for the channelization in a RB

FIG. 18
PRIOR ART

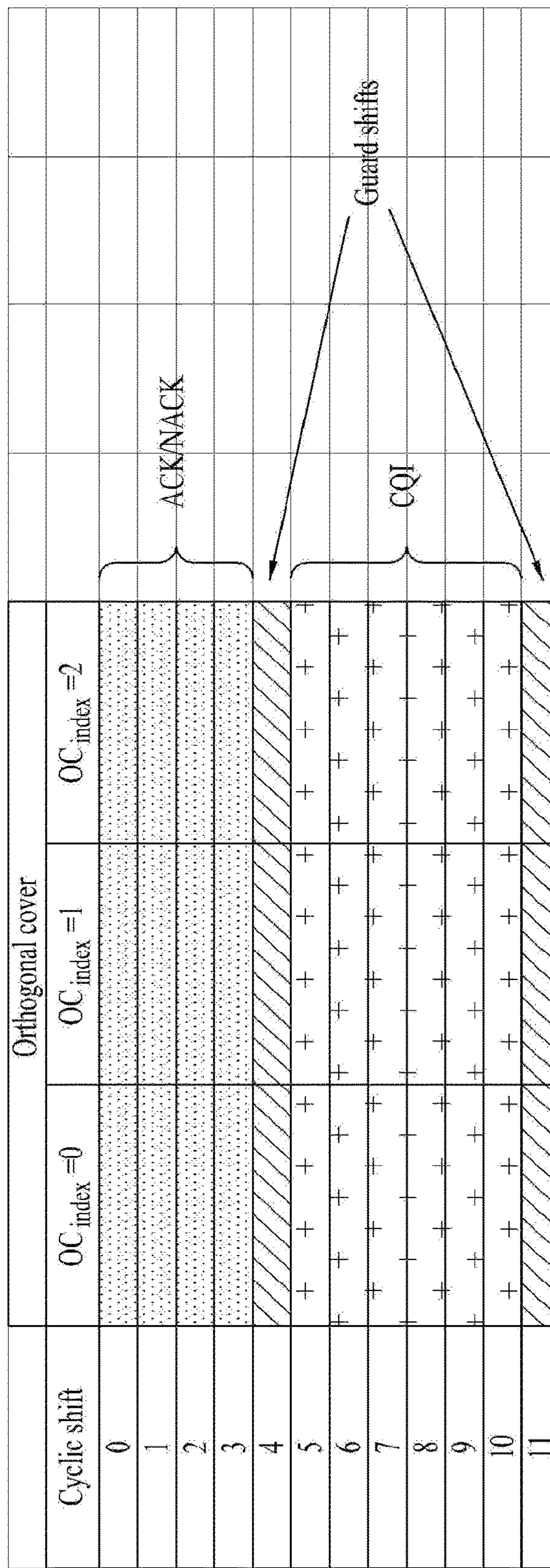

Amended

FIG. 19
PRIOR ART

□ PRBs to be used for transmission of PUCCH in slot n_s

$$n_{PRB} = \begin{cases} \left\lfloor \frac{m}{2} \right\rfloor & \text{if } (m + n_s \bmod 2) \bmod 2 = 0 \\ N_{RB}^{UL} - 1 - \left\lfloor \frac{m}{2} \right\rfloor & \text{if } (m + n_s \bmod 2) \bmod 2 = 1 \end{cases}$$

- Mapping order :
From RBs in outer edge to RBs in inner edge
- PUCCH format 2/2a/2b first
- Secondly mixed ACK/NACK and CQI format
- PUCCH format 1/1a/1b

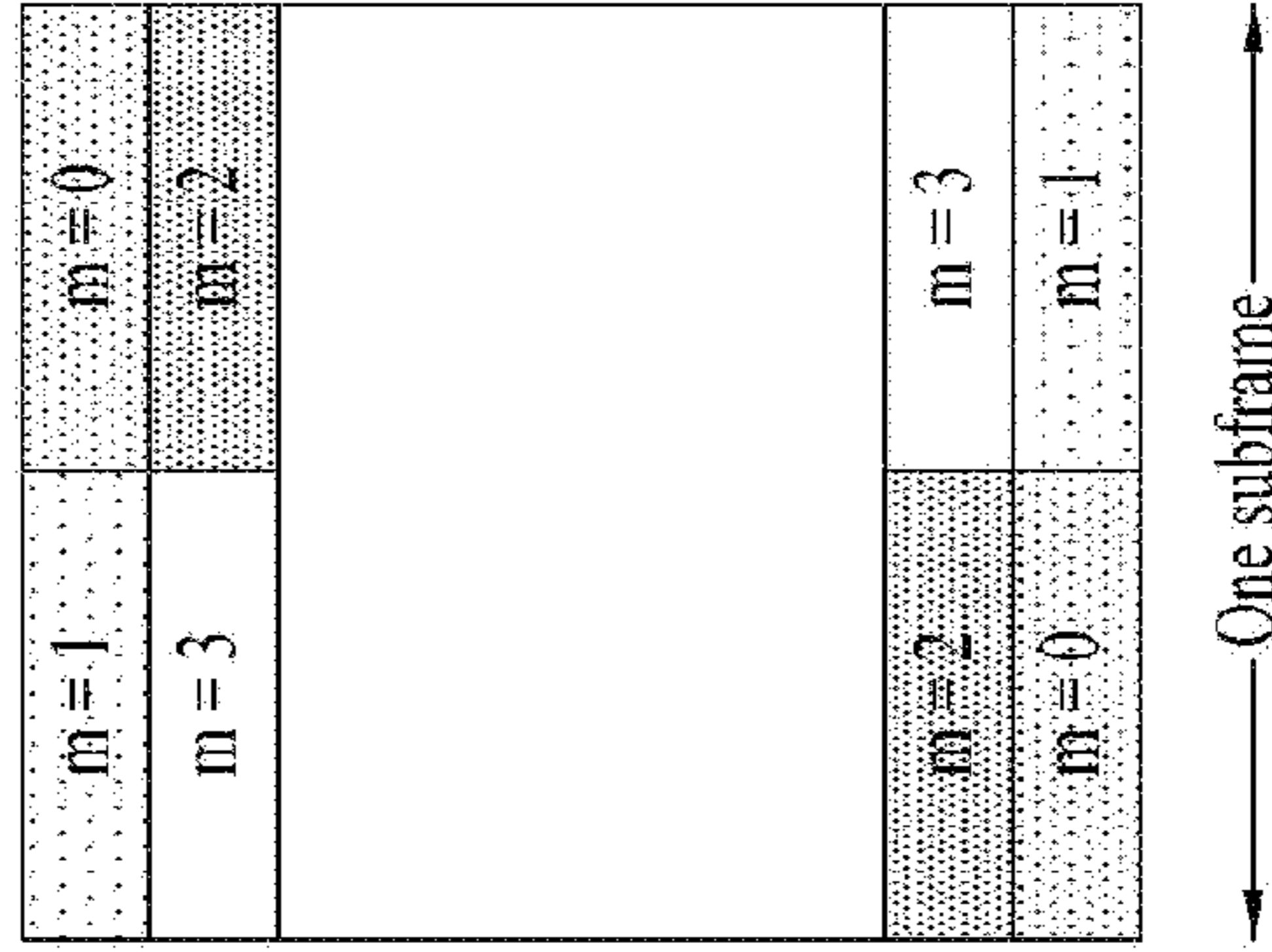
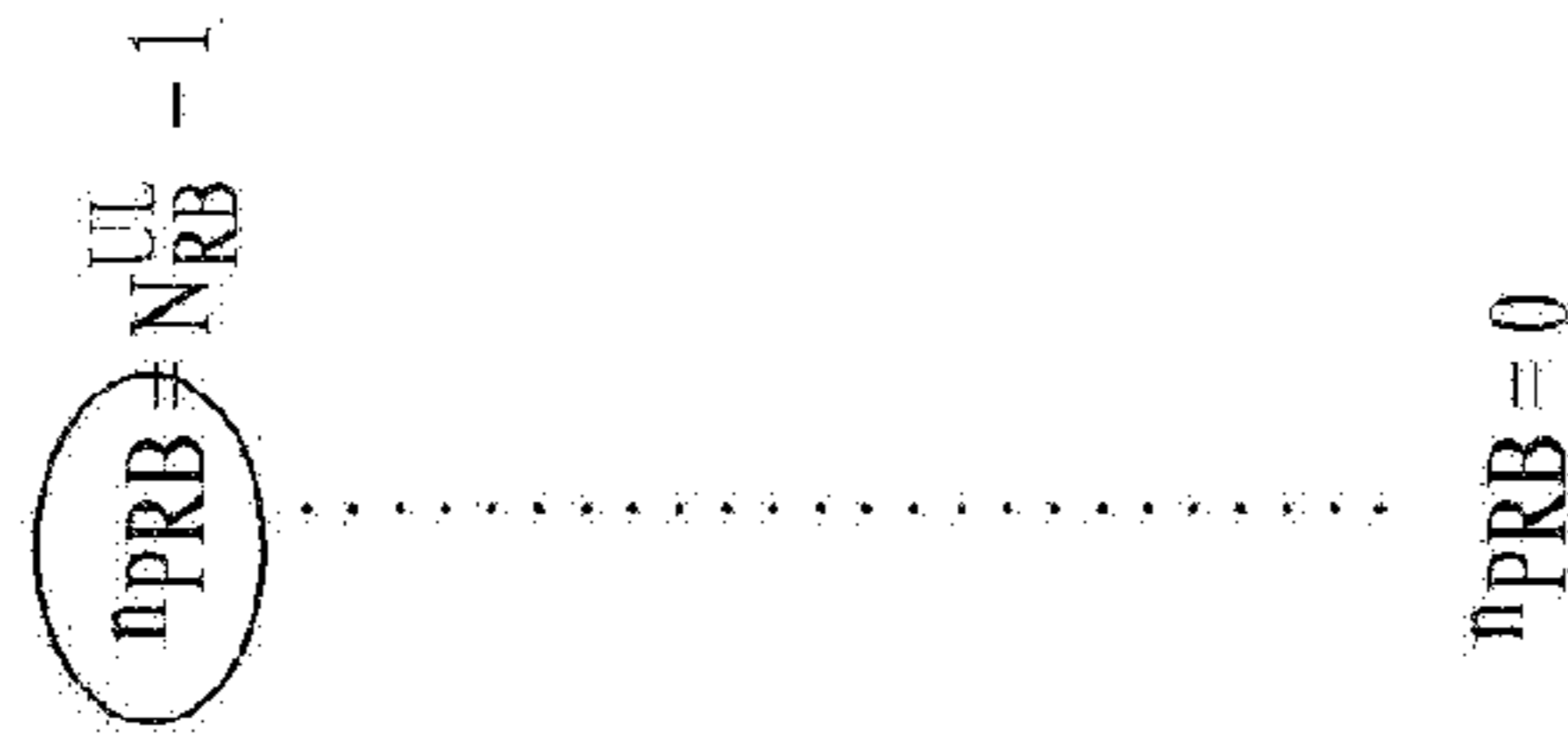

PUCCH Format 1/1a/1b

$$m = \begin{cases} N_{RB}^{(2)} & \text{if } n_{PUCCH}^{(1)} < c \cdot N_{cs}^{(1)} / \Delta_{\text{shift}}^{PUCCH} \\ \left\lfloor \frac{n_{PUCCH}^{(1)} - c \cdot N_{cs}^{(1)} / \Delta_{\text{shift}}^{PUCCH}}{c \cdot N_{cs}^{RB} / \Delta_{\text{shift}}^{PUCCH}} \right\rfloor + N_{RB}^{(2)} & \text{otherwise} \end{cases}$$

$c = \begin{cases} 3 & \text{normal cyclic prefix} \\ 2 & \text{extended cyclic prefix} \end{cases}$

PUCCH Format 2/2a/2b

$$m = \left\lfloor \frac{n_{PUCCH}^{(2)}}{N_{sc}^{RB}} \right\rfloor$$

FIG. 20
PRIOR ART

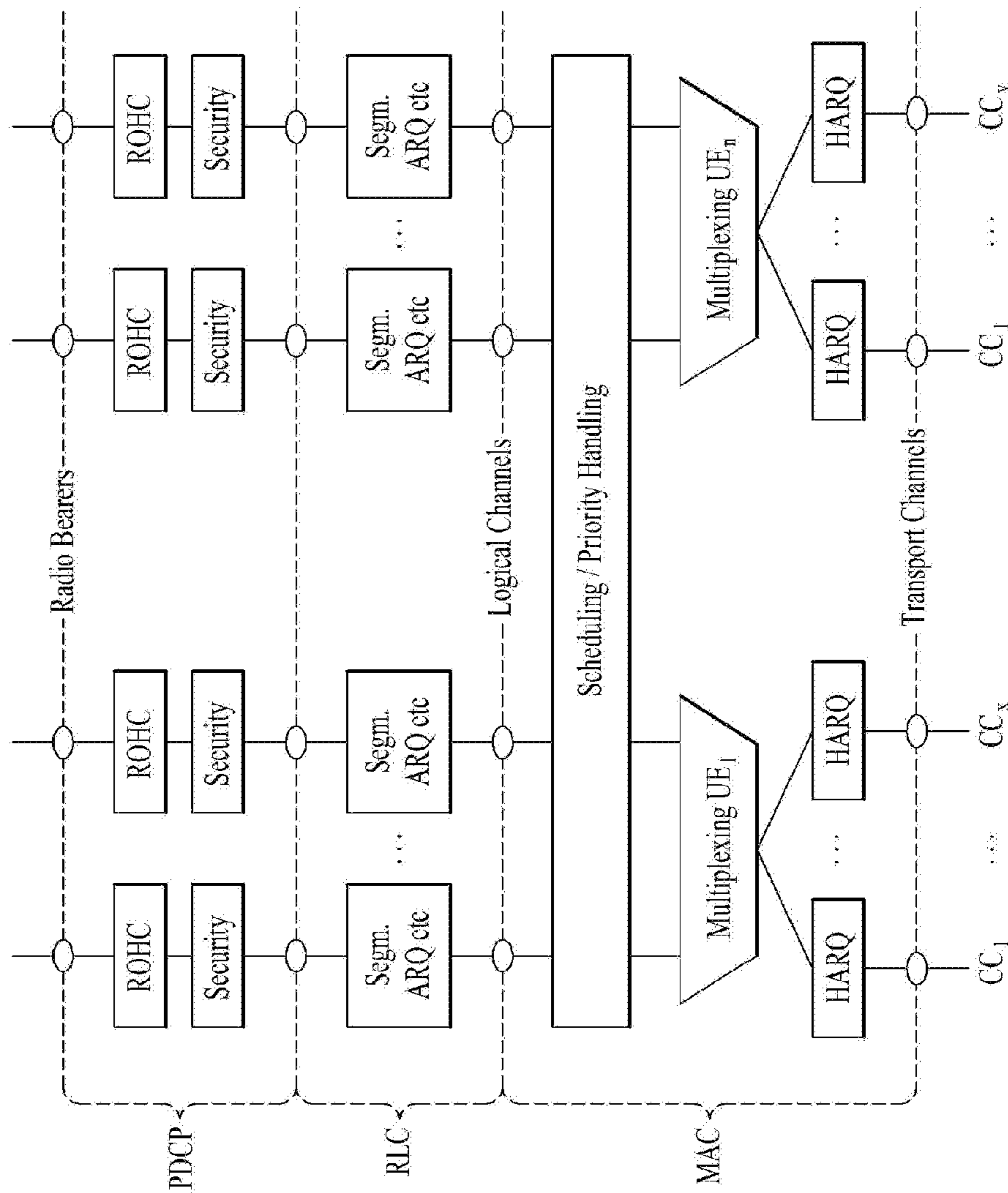

Amended

FIG. 21
PRIOR ART

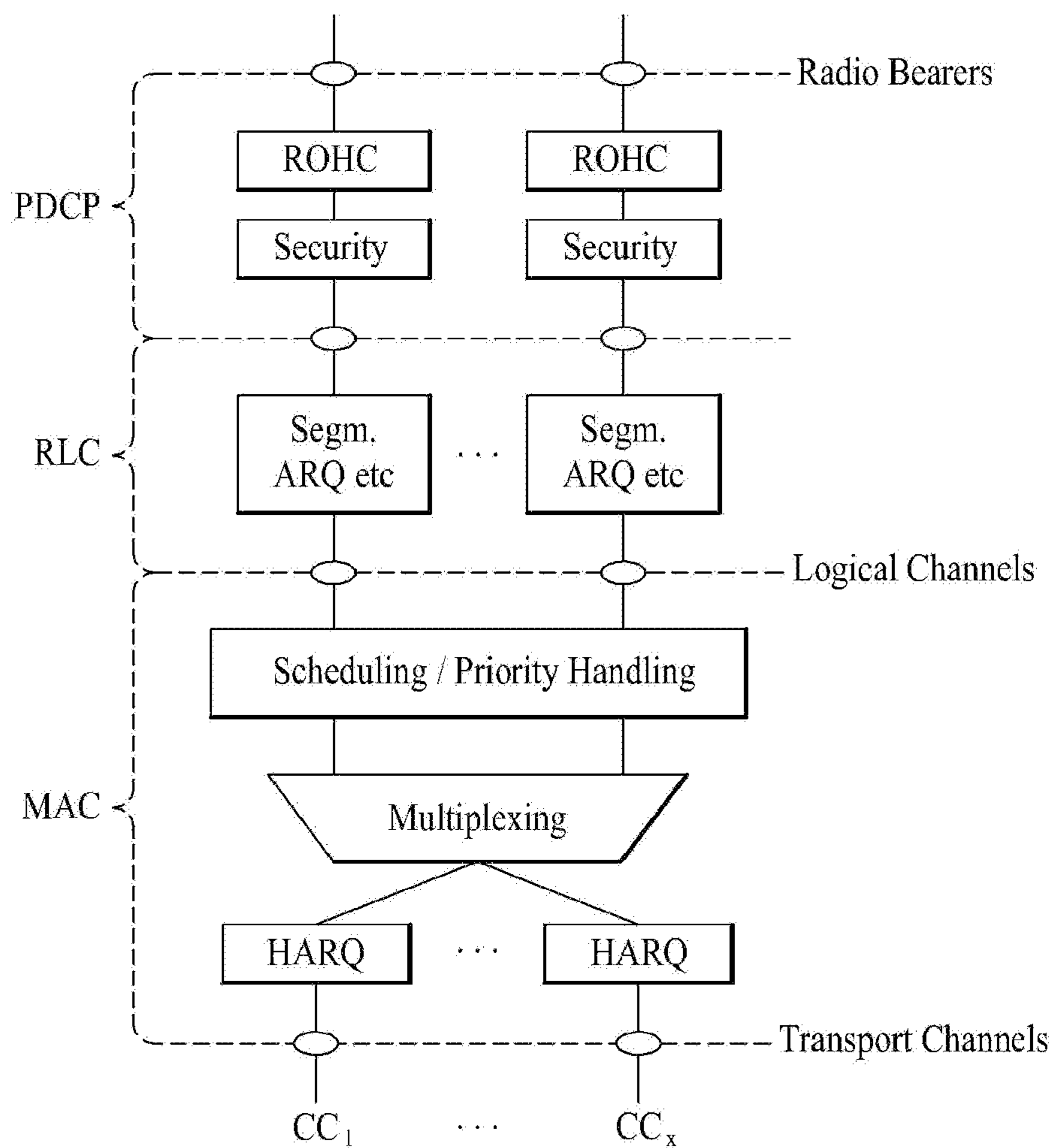

Amended

FIG. 22
PRIOR ART

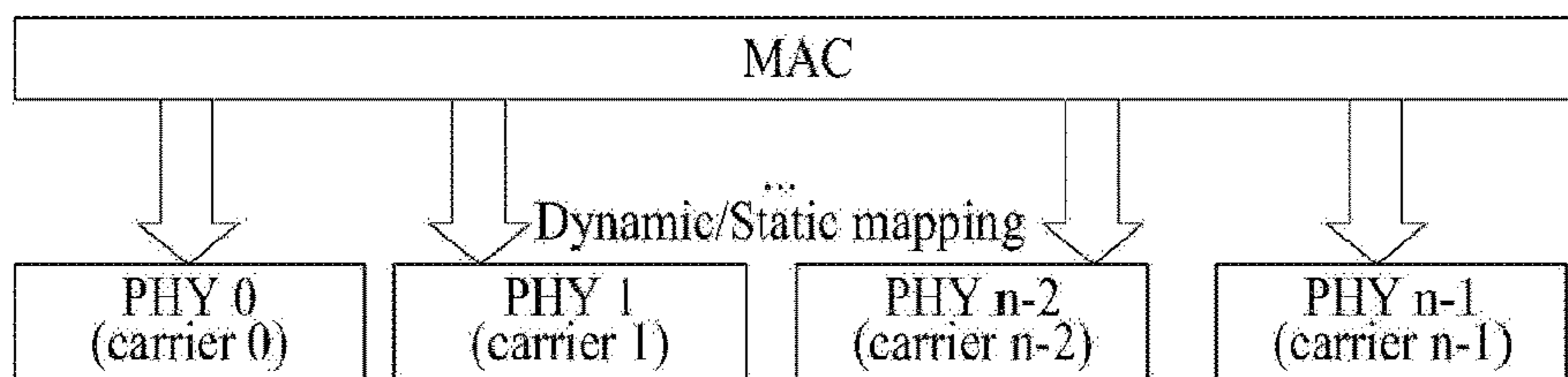

FIG. 23
PRIOR ART

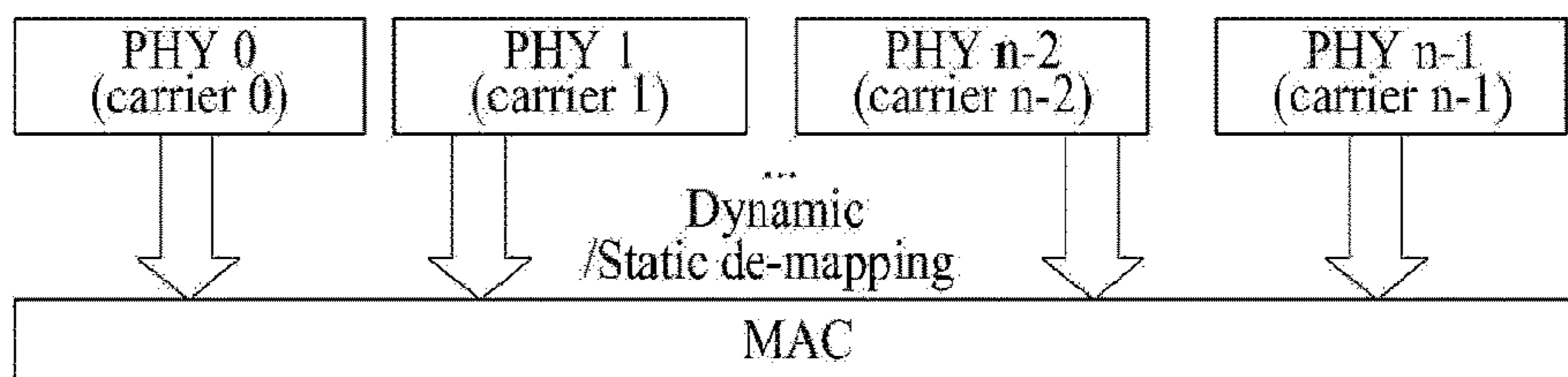

FIG. 24
PRIOR ART

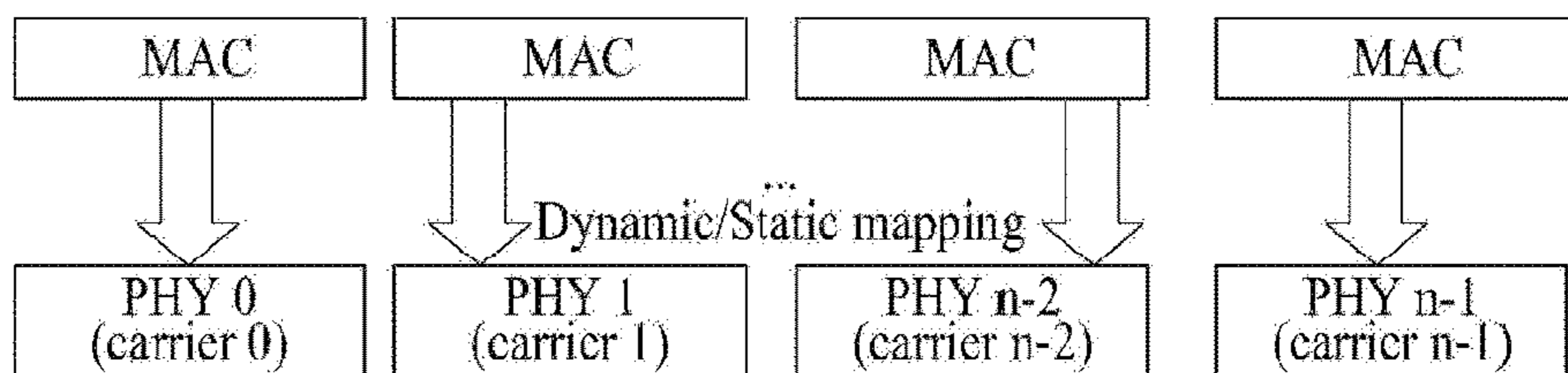

FIG. 25
PRIOR ART

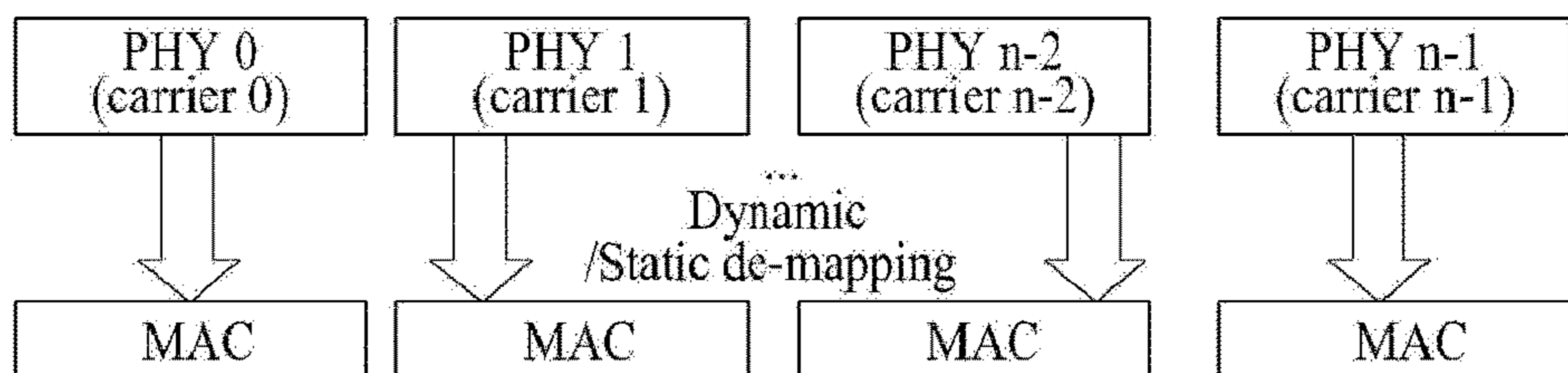

FIG. 26
PRIOR ART

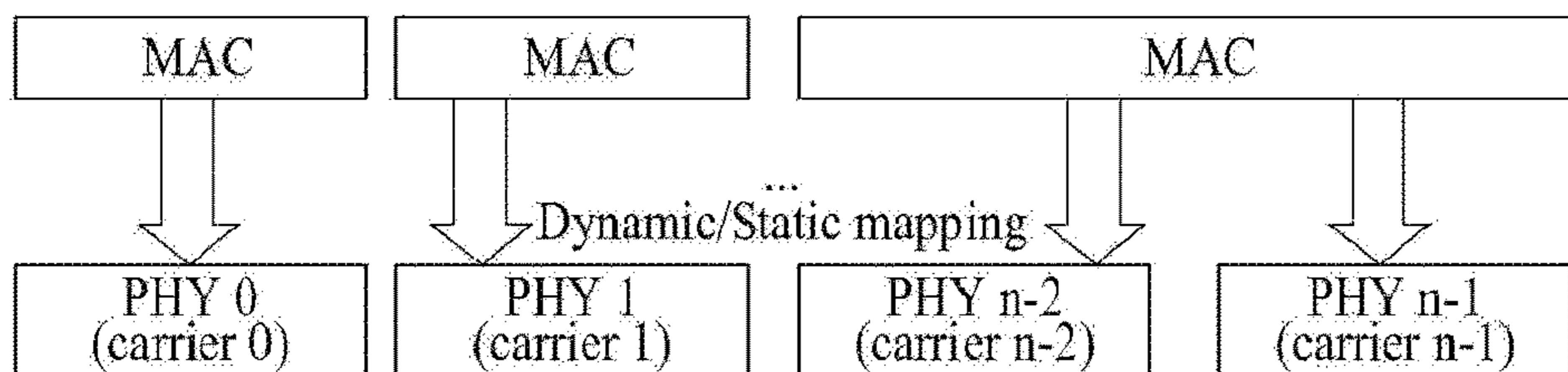

FIG. 27
PRIOR ART

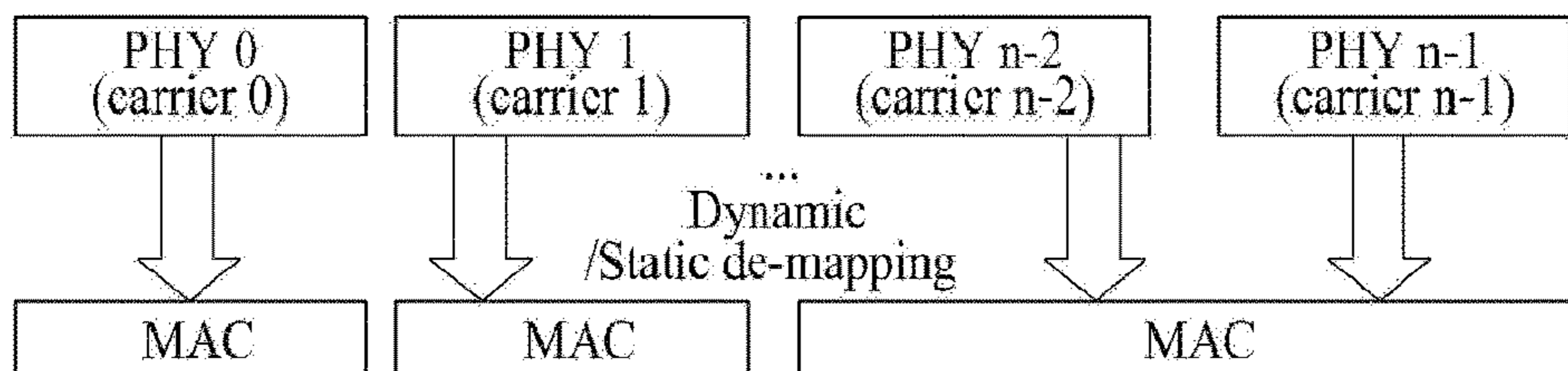
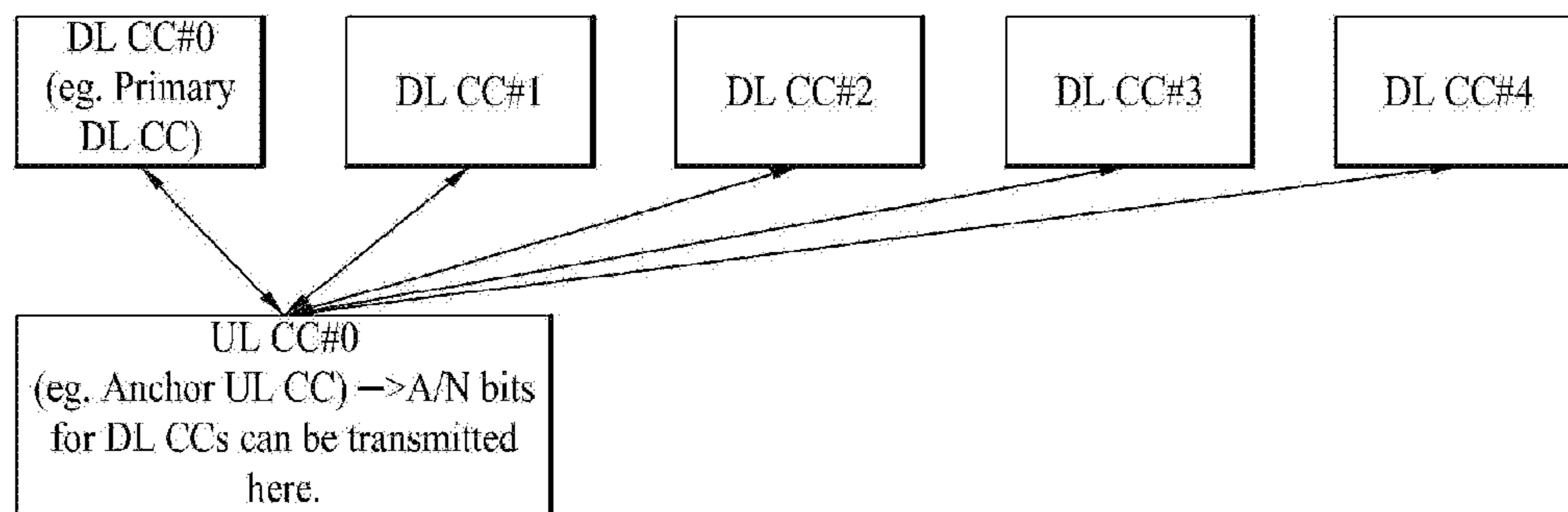

FIG. 28
PRIOR ART



Amended

FIG. 29A

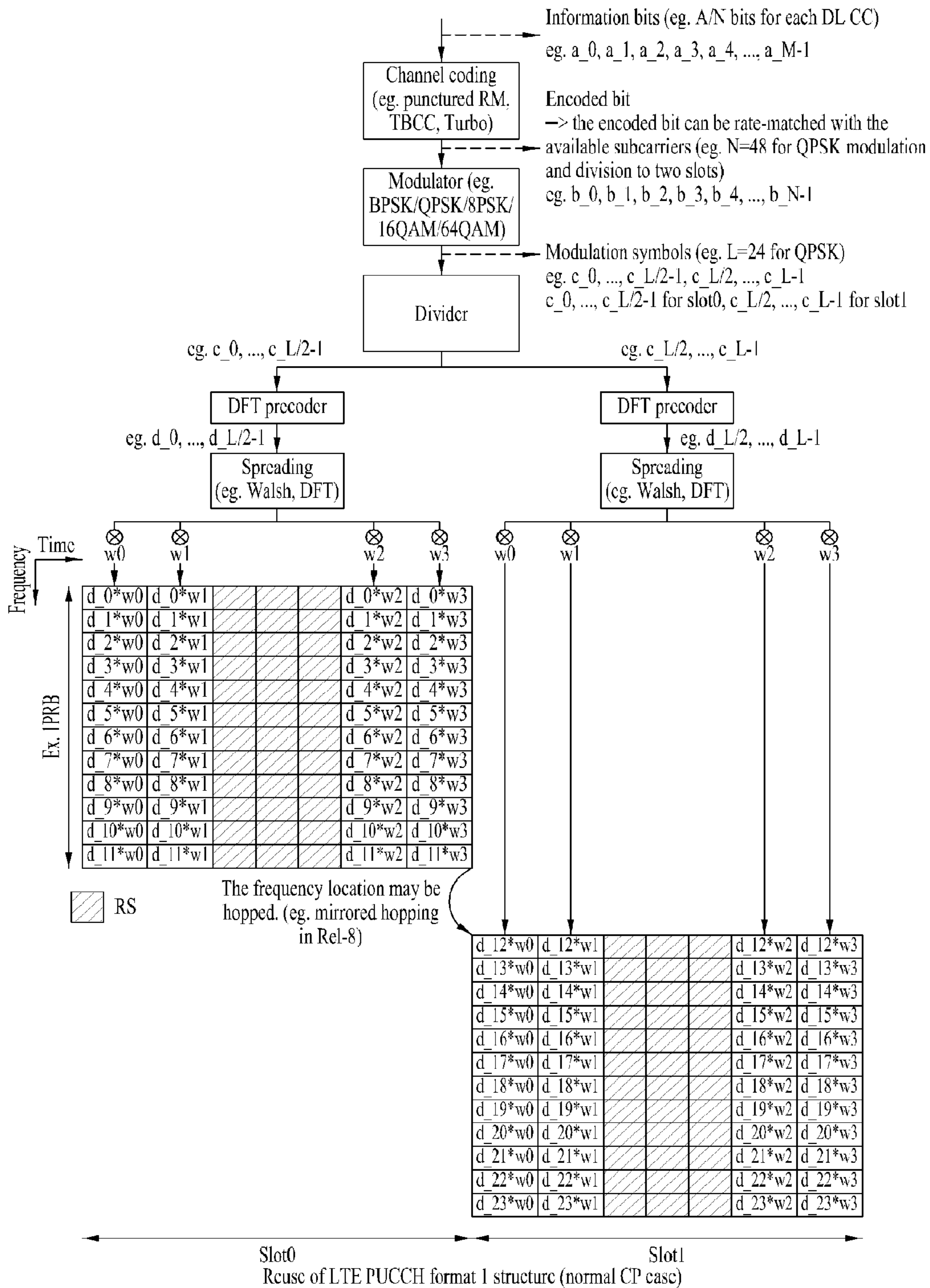

FIG. 29B

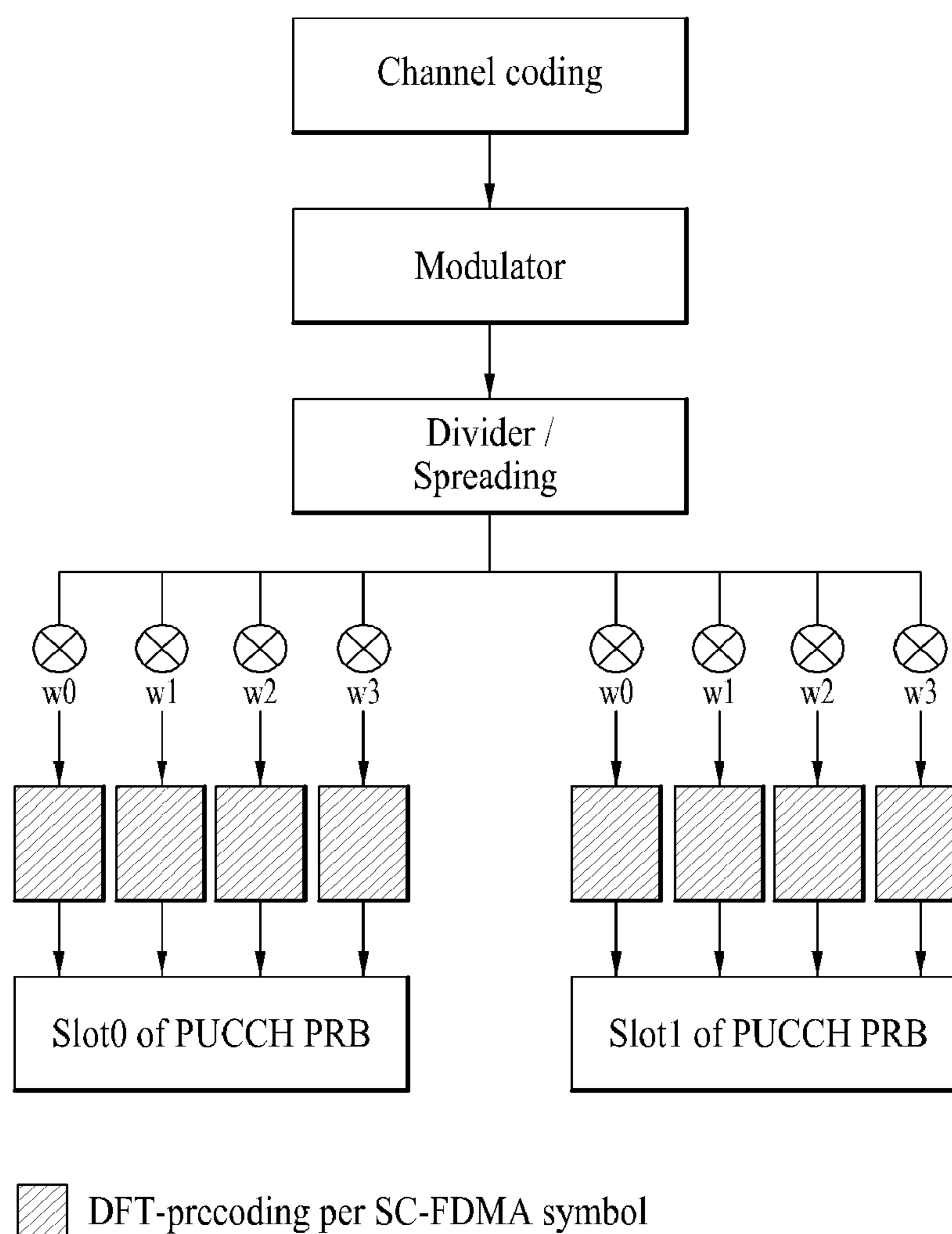

FIG. 29C

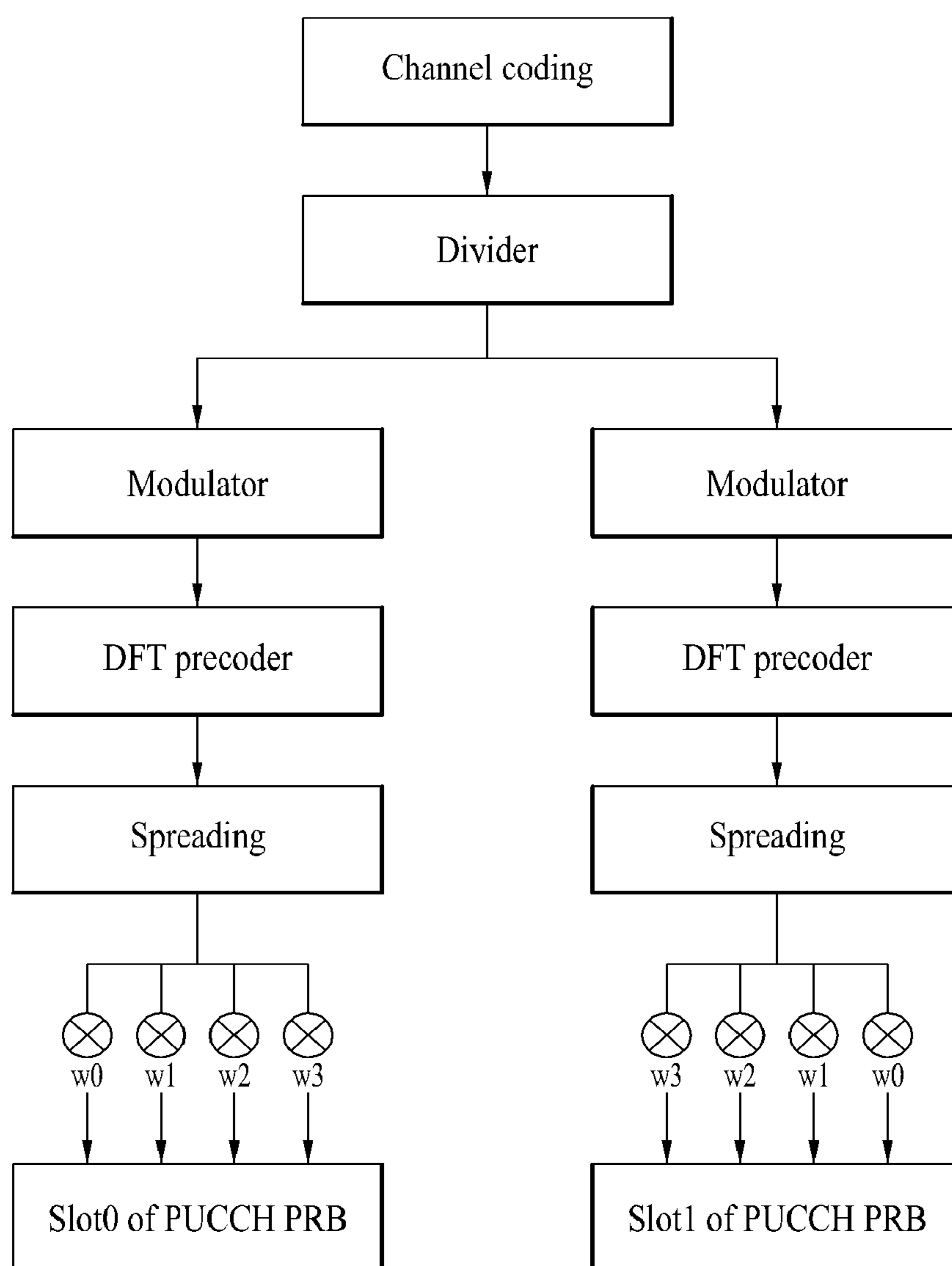

FIG. 29D

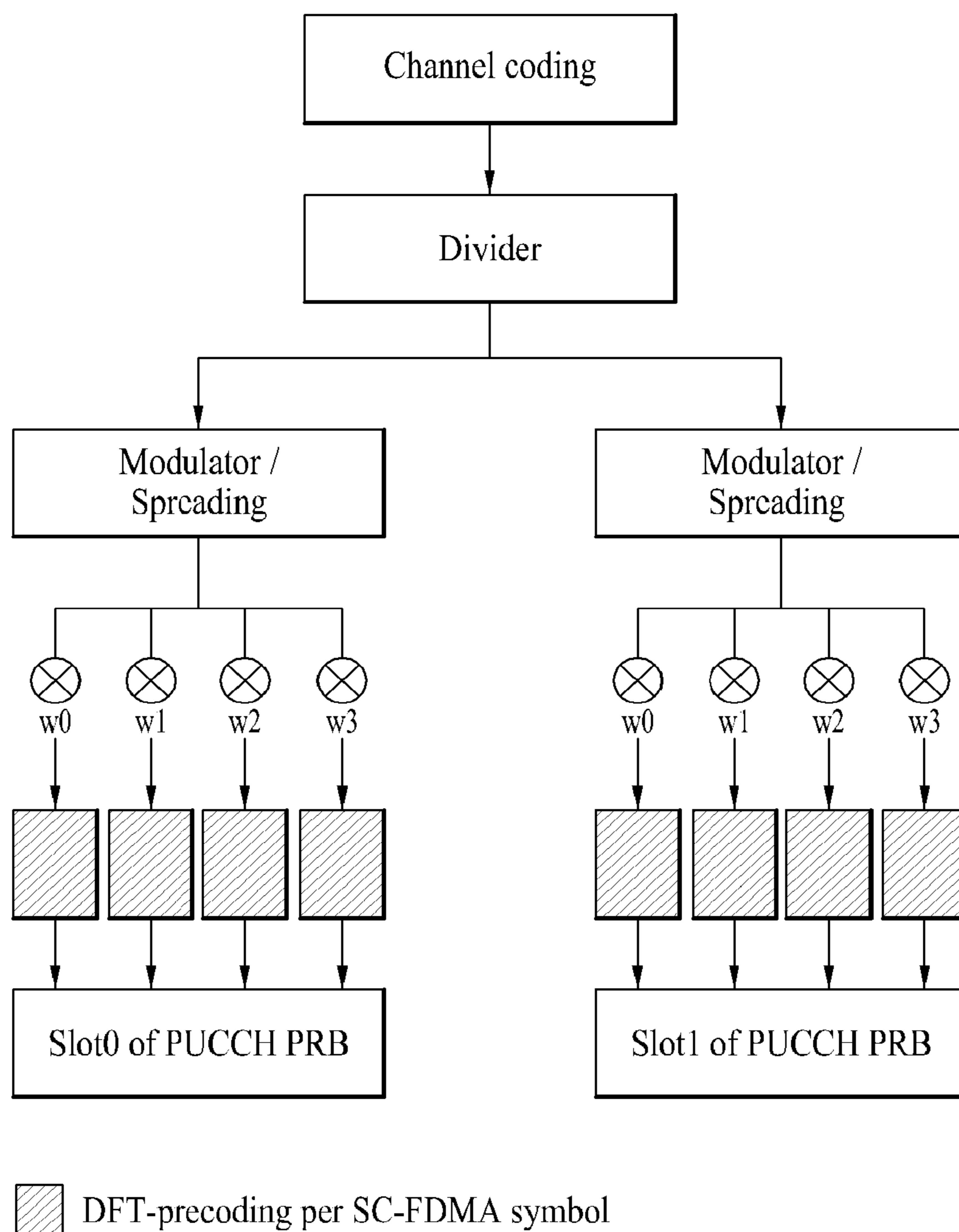

FIG. 29E

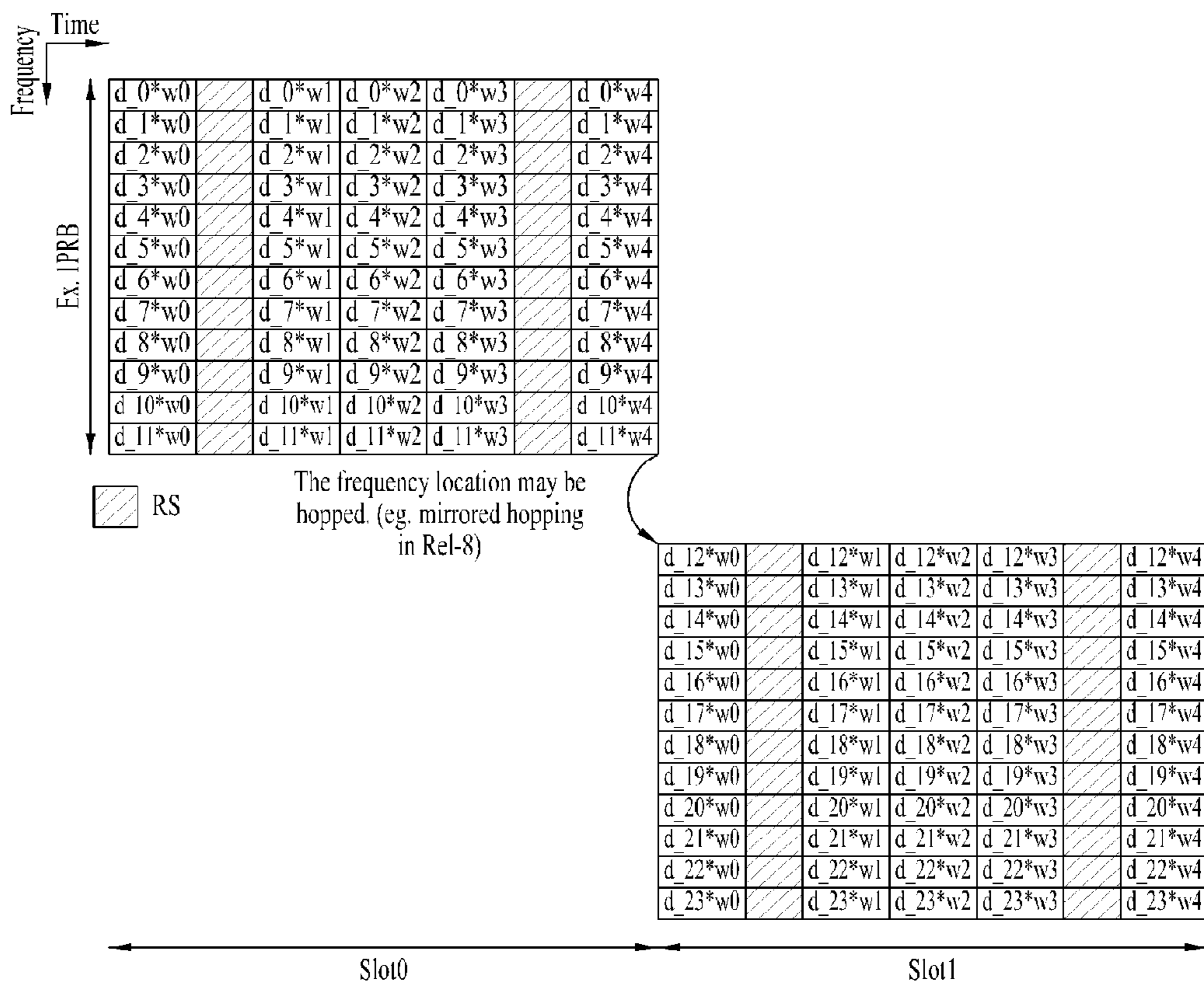
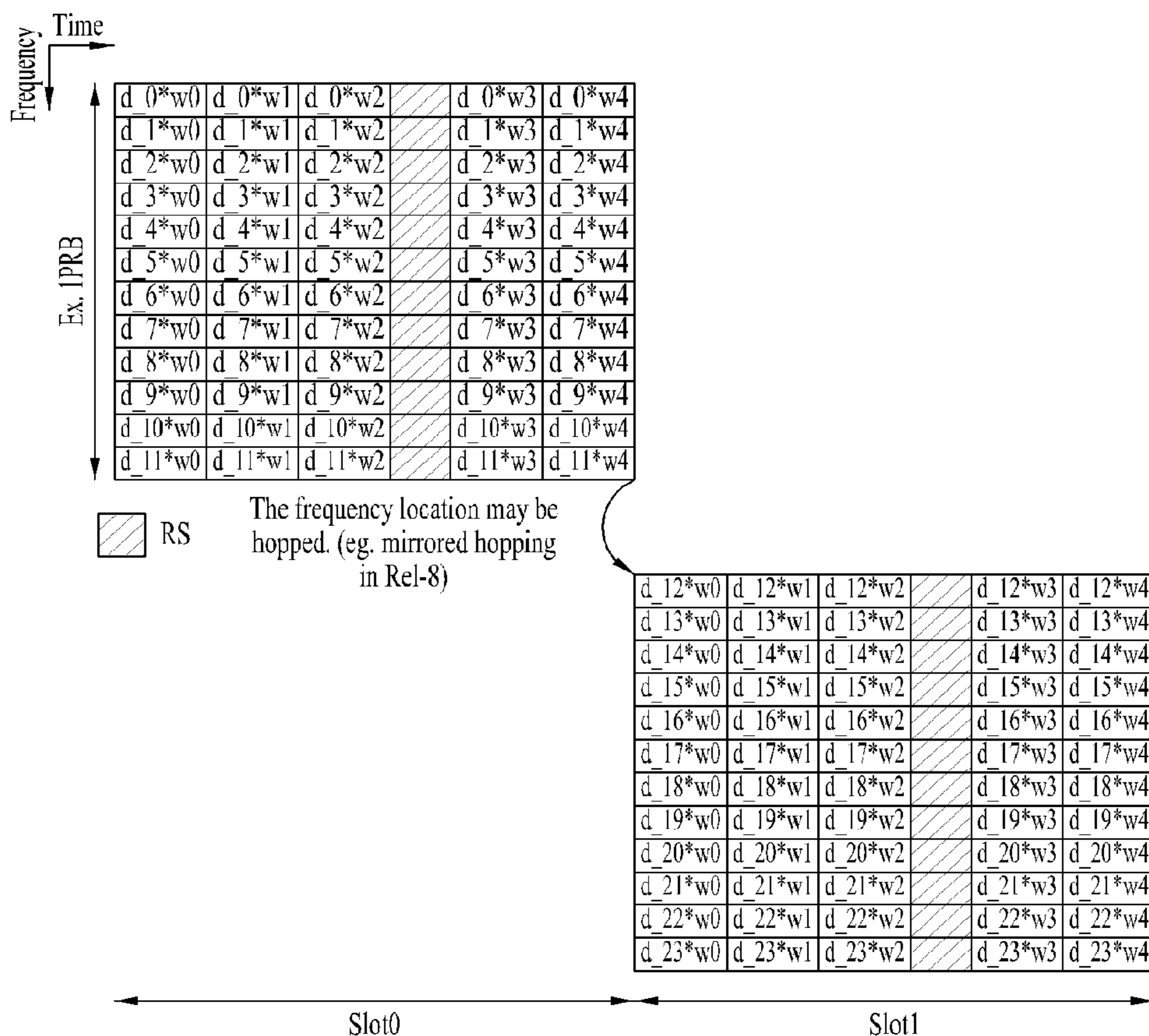

FIG. 29F



Reuse of LTE PUCCH format 2 structure (extended CP case)

FIG. 30

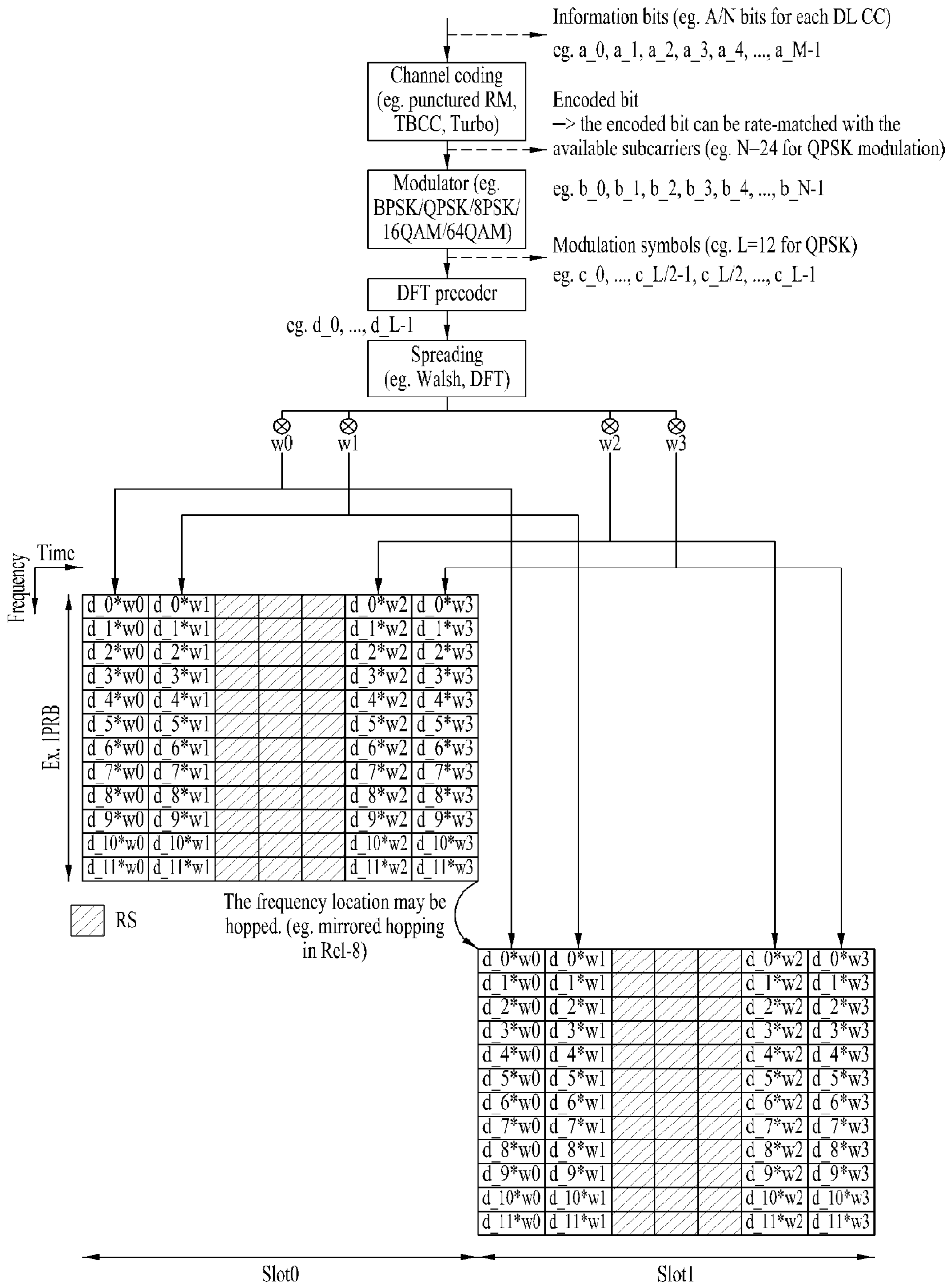

FIG. 31

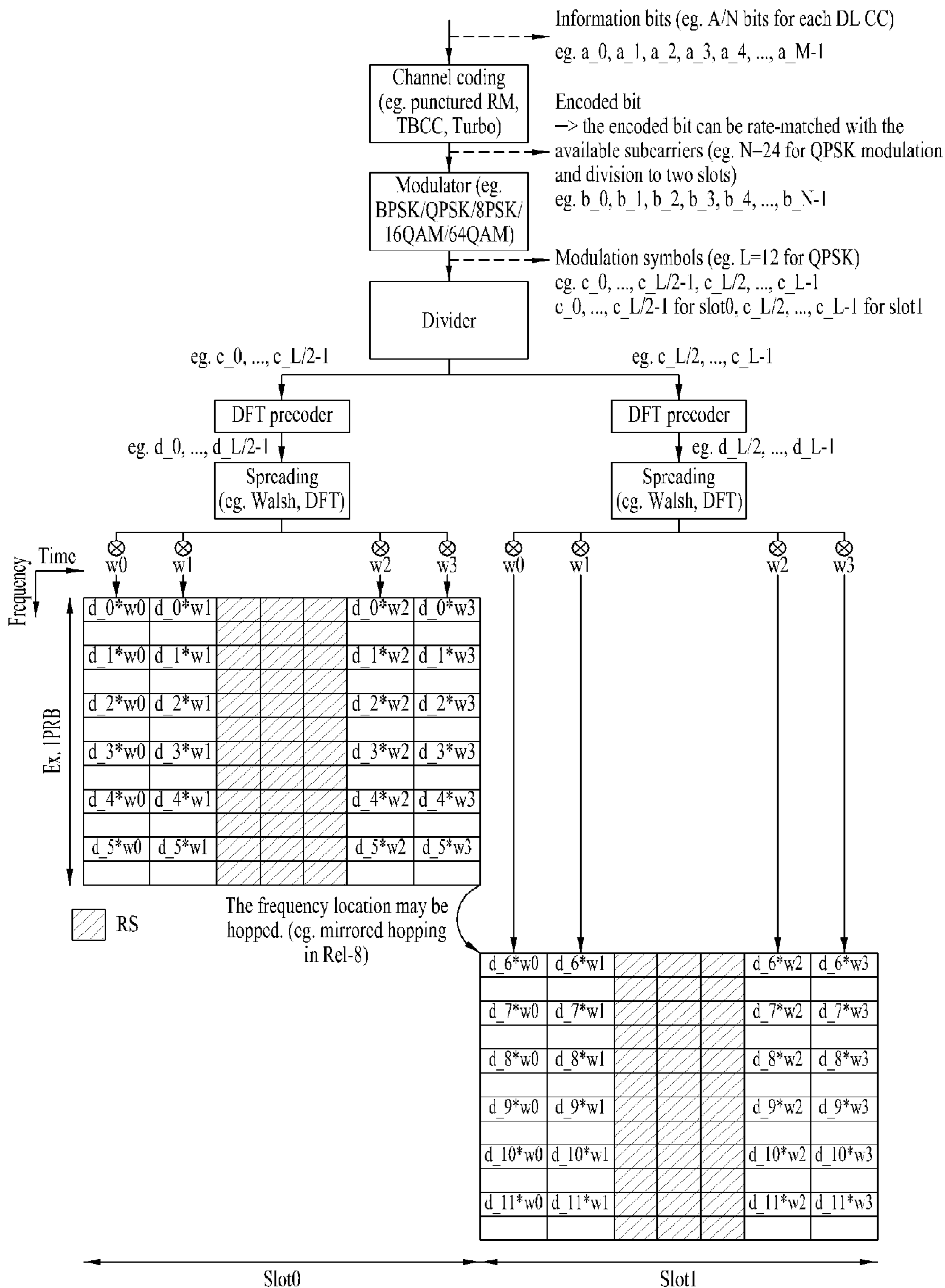

FIG. 33

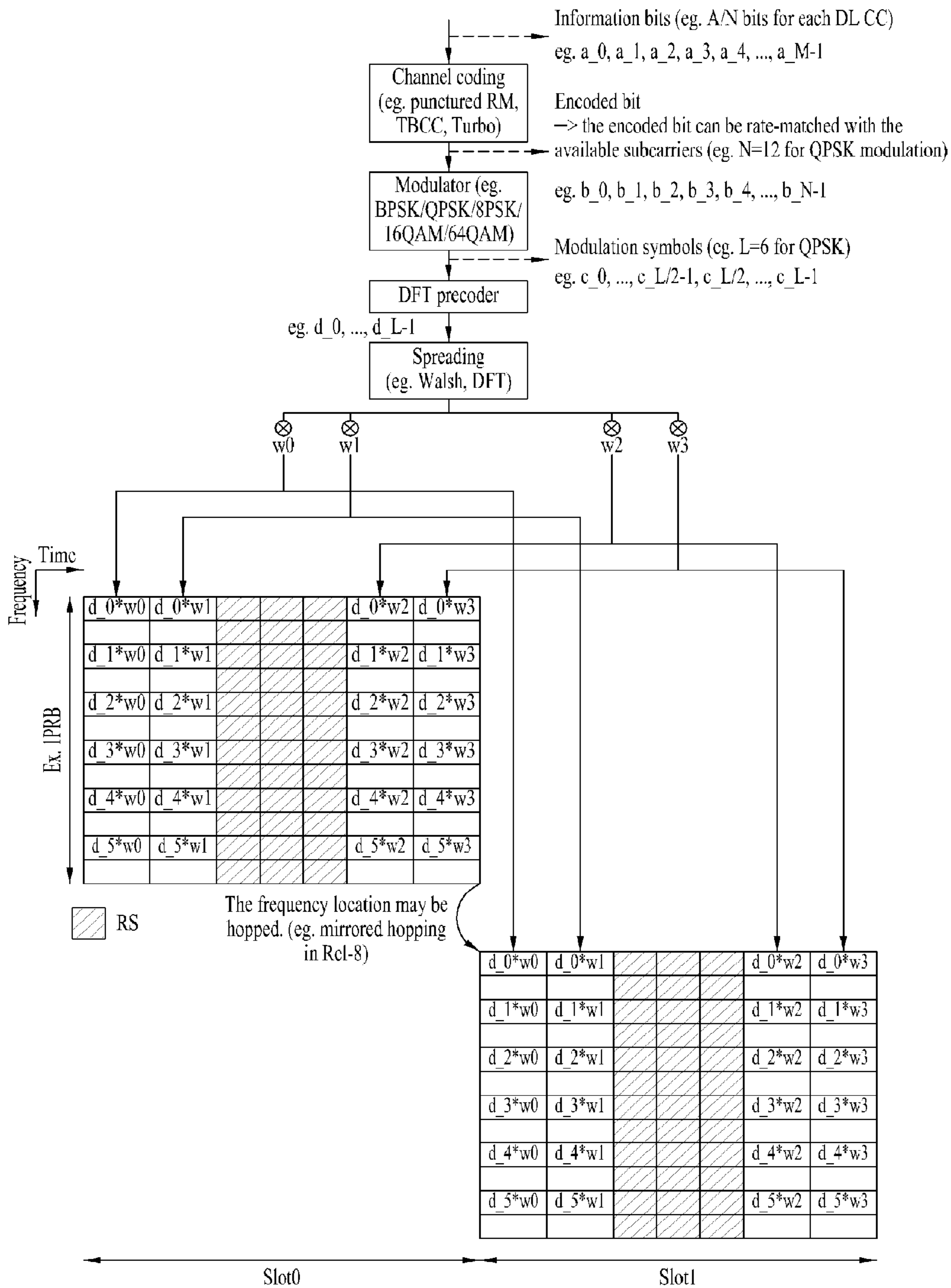

FIG. 34

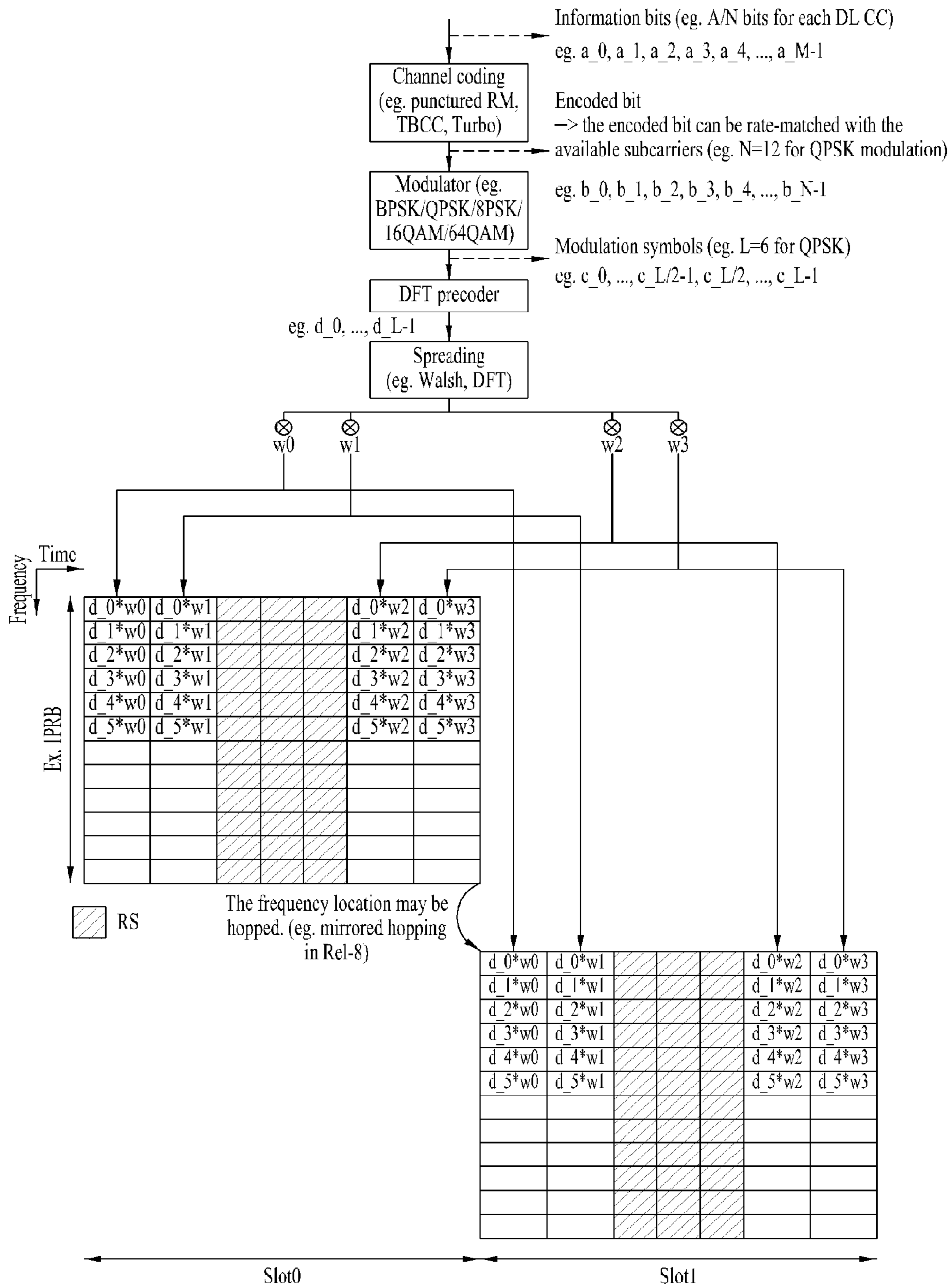

FIG. 35A

Orthogonal code index

Subcarrier index

	0	1	2	3
0	0	1	2	3
1	0	1	2	3
2	0	1	2	3
3	0	1	2	3
4	0	1	2	3
5	0	1	2	3
6	0	1	2	3
7	0	1	2	3
8	0	1	2	3
9	0	1	2	3
10	0	1	2	3
11	0	1	2	3

When frequency factor = 1

FIG. 35B

Orthogonal code index

Subcarrier index

May not be able to be used due to the limitation from RS multiplexing

	0	1	2	3
0	0	1	2	3
1	0	1	2	3
2	0	1	2	3
3	0	1	2	3
4	0	1	2	3
5	0	1	2	3
6	0	1	2	3
7	0	1	2	3
8	0	1	2	3
9	0	1	2	3
10	0	1	2	3
11	0	1	2	3

When frequency factor = 1

FIG. 36A

Orthogonal code index

Subcarrier index

	0	1	2	3
0	0	2	4	6
1	1	3	5	7
2	0	2	4	6
3	1	3	5	7
4	0	2	4	6
5	1	3	5	7
6	0	2	4	6
7	1	3	5	7
8	0	2	4	6
9	1	3	5	7
10	0	2	4	6
11	1	3	5	7

When frequency factor = 2

FIG. 36B

May not be able to be used due to the limitation from RS multiplexing

Orthogonal code index

Subcarrier index

	0	1	2	3
0	0	2	4	6
1	1	3	5	7
2	0	2	4	6
3	1	3	5	7
4	0	2	4	6
5	1	3	5	7
6	0	2	4	6
7	1	3	5	7
8	0	2	4	6
9	1	3	5	7
10	0	2	4	6
11	1	3	5	7

When frequency factor = 2

FIG. 37A

Orthogonal code index

Subcarrier index

	0	1	2	3
0	0	3	6	9
1	1	4	7	10
2	2	5	8	11
3	0	3	6	9
4	1	4	7	10
5	2	5	8	11
6	0	3	6	9
7	1	4	7	10
8	2	5	8	11
9	0	3	6	9
10	1	4	7	10
11	2	5	8	11

When frequency factor = 3

FIG. 37B

May not be able to be used due to the limitation from RS multiplexing

Orthogonal code index

Subcarrier index

	0	1	2	3
0	0	3	6	9
1	1	4	7	10
2	2	5	8	11
3	0	3	6	9
4	1	4	7	10
5	2	5	8	11
6	0	3	6	9
7	1	4	7	10
8	2	5	8	11
9	0	3	6	9
10	1	4	7	10
11	2	5	8	11

When frequency factor = 3

FIG. 38A

Orthogonal code index

Subcarrier index

	0	1	2	3
0	0	4	8	12
1	1	5	9	13
2	2	6	10	14
3	3	7	11	15
4	0	4	8	12
5	1	5	9	13
6	2	6	10	14
7	3	7	11	15
8	0	4	8	12
9	1	5	9	13
10	2	6	10	14
11	3	7	11	15

When frequency factor = 4

FIG. 38B

May not be able to be used due to the limitation from RS multiplexing

Orthogonal code index

Subcarrier index

	0	1	2	3
0	0	4	8	12
1	1	5	9	13
2	2	6	10	14
3	3	7	11	15
4	0	4	8	12
5	1	5	9	13
6	2	6	10	14
7	3	7	11	15
8	0	4	8	12
9	1	5	9	13
10	2	6	10	14
11	3	7	11	15

When frequency factor = 4

FIG. 39A

Orthogonal code index

Subcarrier index

	0	1	2	3
0	0	6	12	18
1	1	7	13	19
2	2	8	14	20
3	3	9	15	21
4	4	10	16	22
5	5	11	17	23
6	0	6	12	18
7	1	7	13	19
8	2	8	14	20
9	3	9	15	21
10	4	10	16	22
11	5	11	17	23

When frequency factor = 6

FIG. 39B

May not be able to be used due to the limitation from RS multiplexing

Orthogonal code index

Subcarrier index

	0	1	2	3
0	0	6	12	18
1	1	7	13	19
2	2	8	14	20
3	3	9	15	21
4	4	10	16	22
5	5	11	17	23
6	0	6	12	18
7	1	7	13	19
8	2	8	14	20
9	3	9	15	21
10	4	10	16	22
11	5	11	17	23

When frequency factor = 6

FIG. 40A

Orthogonal code index

Subcarrier index

	0	1	2	3
0	0	12	24	36
1	1	13	25	37
2	2	14	26	38
3	3	15	27	39
4	4	16	28	40
5	5	17	29	41
6	6	18	30	42
7	7	19	31	43
8	8	20	32	44
9	9	21	33	45
10	10	22	34	46
11	11	23	35	47

When frequency factor = 12

FIG. 40B

May not be able to be used due to the limitation from RS multiplexing

Orthogonal code index

Subcarrier index

	0	1	2	3
0	0	12	24	36
1	1	13	25	37
2	2	14	26	38
3	3	15	27	39
4	4	16	28	40
5	5	17	29	41
6	6	18	30	42
7	7	19	31	43
8	8	20	32	44
9	9	21	33	45
10	10	22	34	46
11	11	23	35	47

When frequency factor = 12

FIG. 41

Orthogonal code index

		0	1	2	3
Subcarrier index	0	0	5	7	9
	1	1	3	8	10
	2	2	4	6	11
	3	0	5	7	9
	4	1	3	8	10
	5	2	4	6	11
	6	0	5	7	9
	7	1	3	8	10
	8	2	4	6	11
	9	0	5	7	9
	10	1	3	8	10
	11	2	4	6	11

When frequency factor = 3

FIG. 42A

Orthogonal code index

		0	1	2
Subcarrier index	↓			
0		0	12	24
1		1	13	25
2		2	14	26
3		3	15	27
4		4	16	28
5		5	17	29
6		6	18	30
7		7	19	31
8		8	20	32
9		9	21	33
10		10	22	34
11		11	23	35

when $\Delta_{\text{shift}}^{\text{PUCCH}} = 1$

FIG. 42B

Orthogonal code index

		0	1	2
Subcarrier index	↓			
0		0		12
1			6	
2		1		13
3			7	
4		2		14
5			8	
6		3		15
7			9	
8		4		16
9			10	
10		5		17
11			11	

when $\Delta_{\text{shift}}^{\text{PUCCH}} = 2$

FIG. 42C

Orthogonal code index

	0	1	2
Subcarrier index			
0	0		
1		4	
2			8
3	1		
4		5	
5			9
6	2		
7		6	
8			10
9	3		
10		7	
11			11

when $\Delta_{\text{shift}}^{\text{PUCCH}} = 3$

FIG. 42D

Orthogonal code index

	0	1	2
Subcarrier index			
0	0		
1		3	
2			6
3			
4	1		
5		4	
6			7
7			
8	2		
9		5	
10			8
11			

when $\Delta_{\text{shift}}^{\text{PUCCH}} = 4$

FIG. 42E

Orthogonal code index

		0	1	2
Subcarrier index	↓			
0		0		
1			2	
2				4
3				
4				
5				
6		1		
7			3	
8				5
9				
10				
11				

when $\Delta_{\text{shift}}^{\text{PUCCH}} = 6$

FIG. 42F

Orthogonal code index

		0	1	2
Subcarrier index	↓			
0		0		
1			1	
2				2
3				
4				
5				
6				
7				
8				
9				
10				
11				

when $\Delta_{\text{shift}}^{\text{PUCCH}} = 12$

FIG. 43A

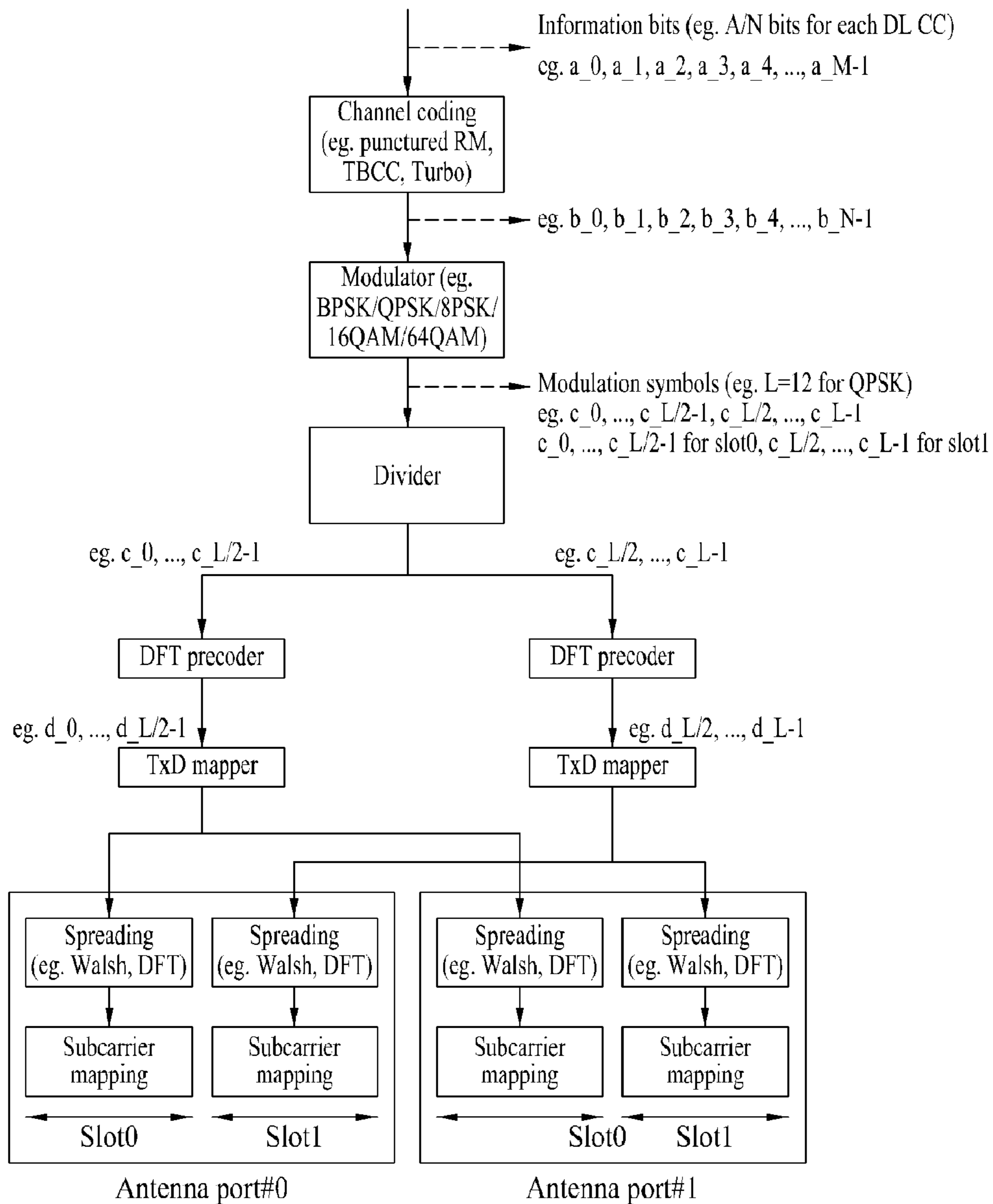

FIG. 43B

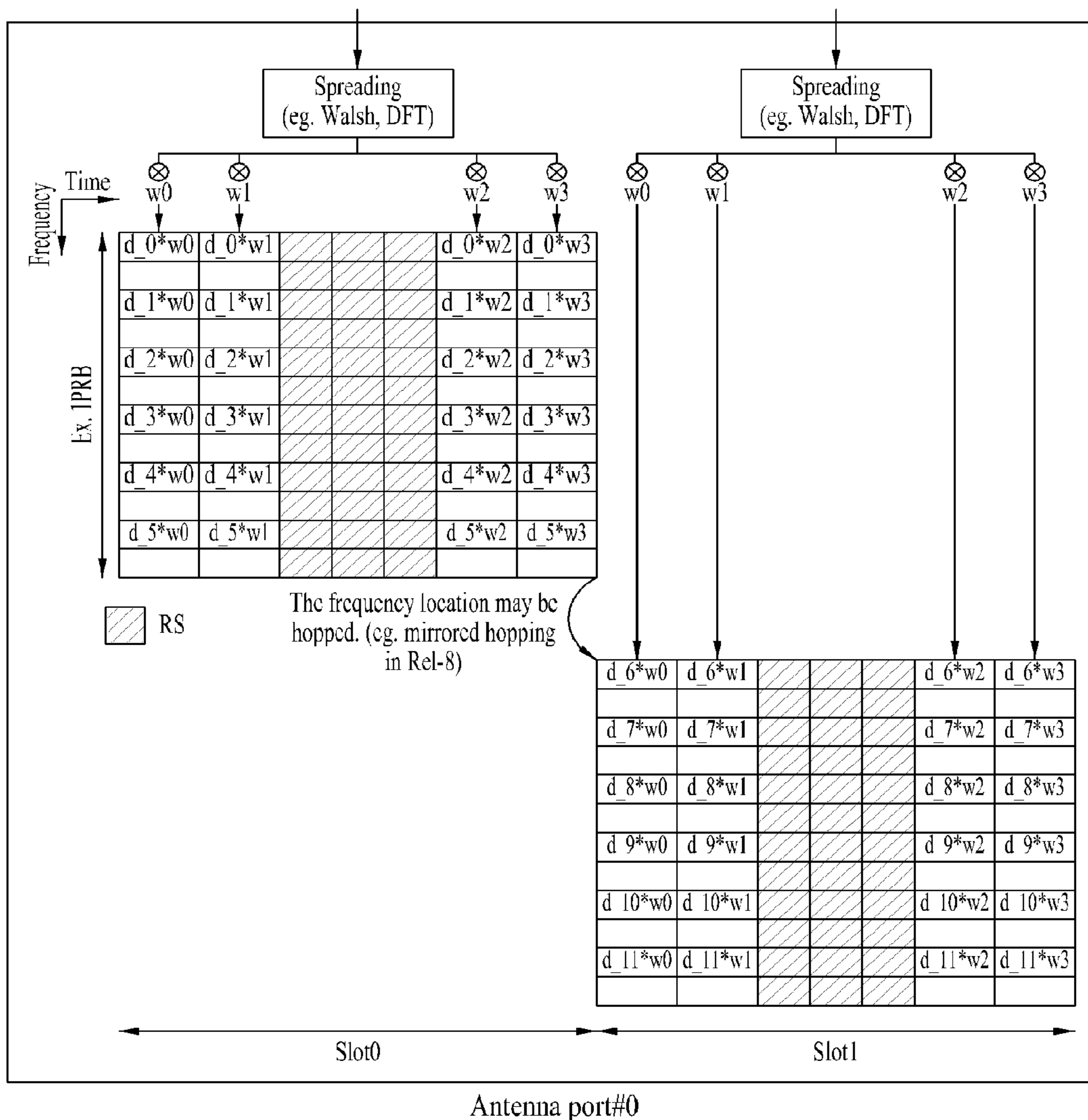

FIG. 43C

$C(\cdot)$: complex conjugate of (\cdot)

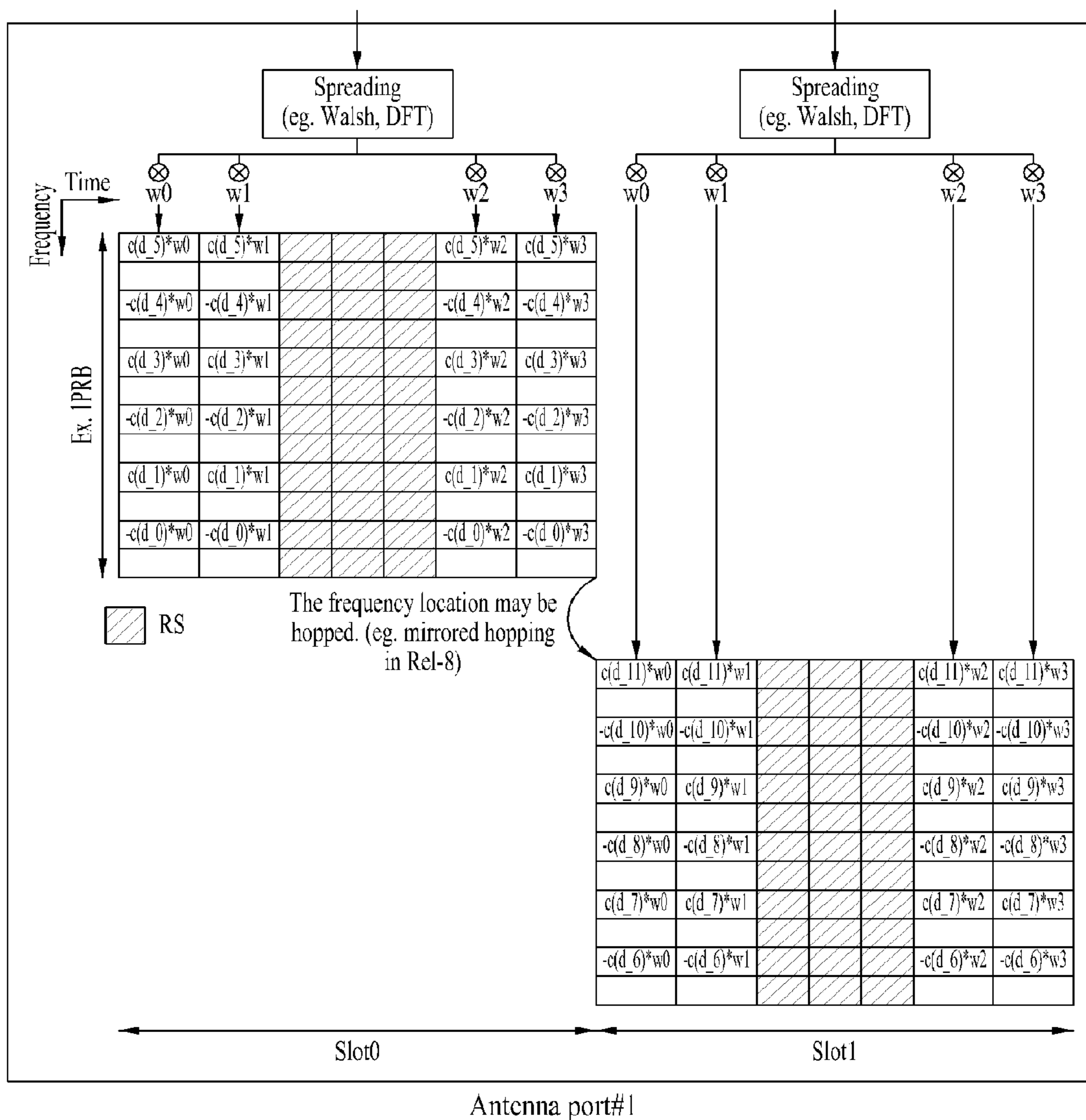

FIG. 44

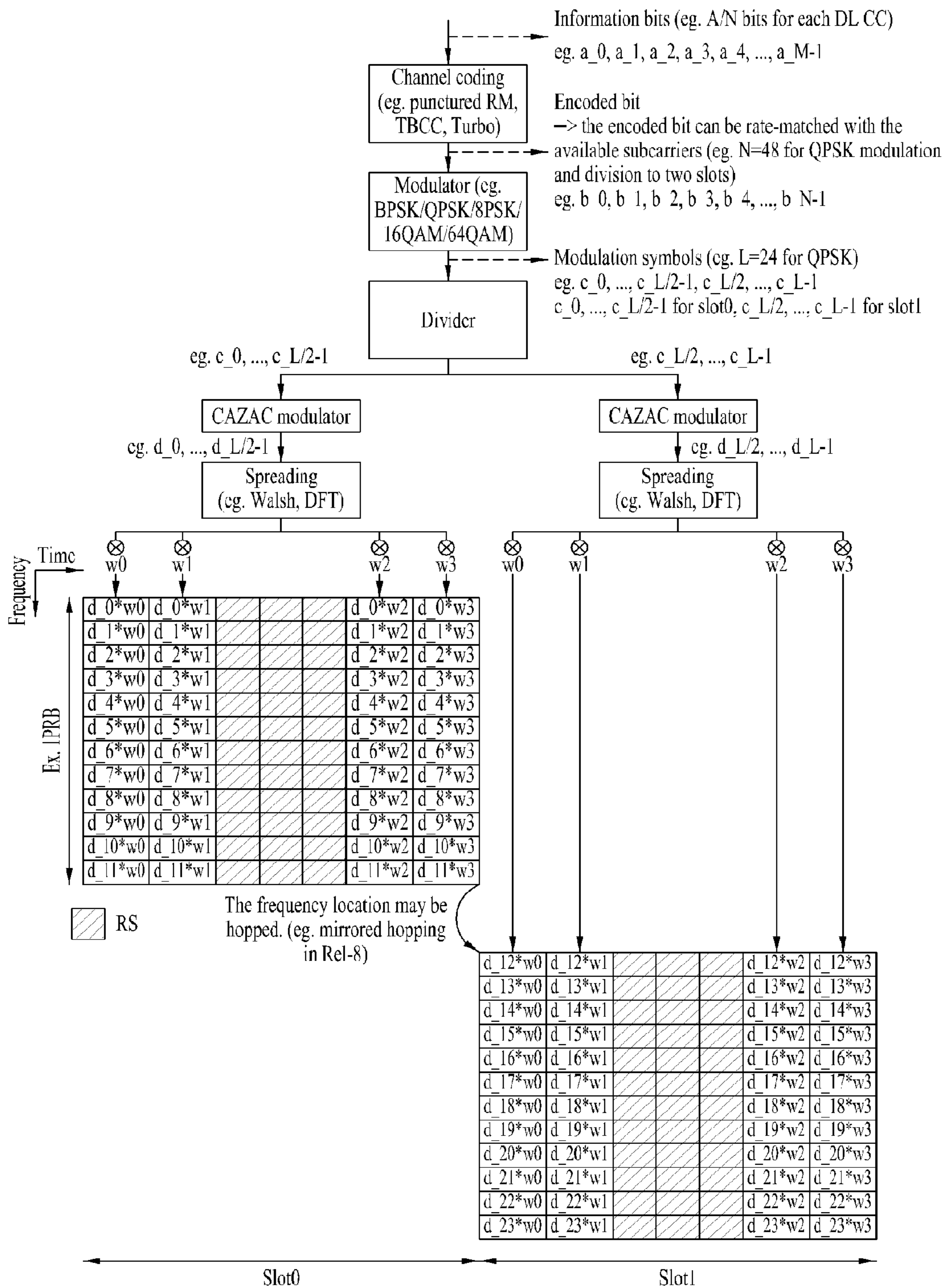

FIG. 45

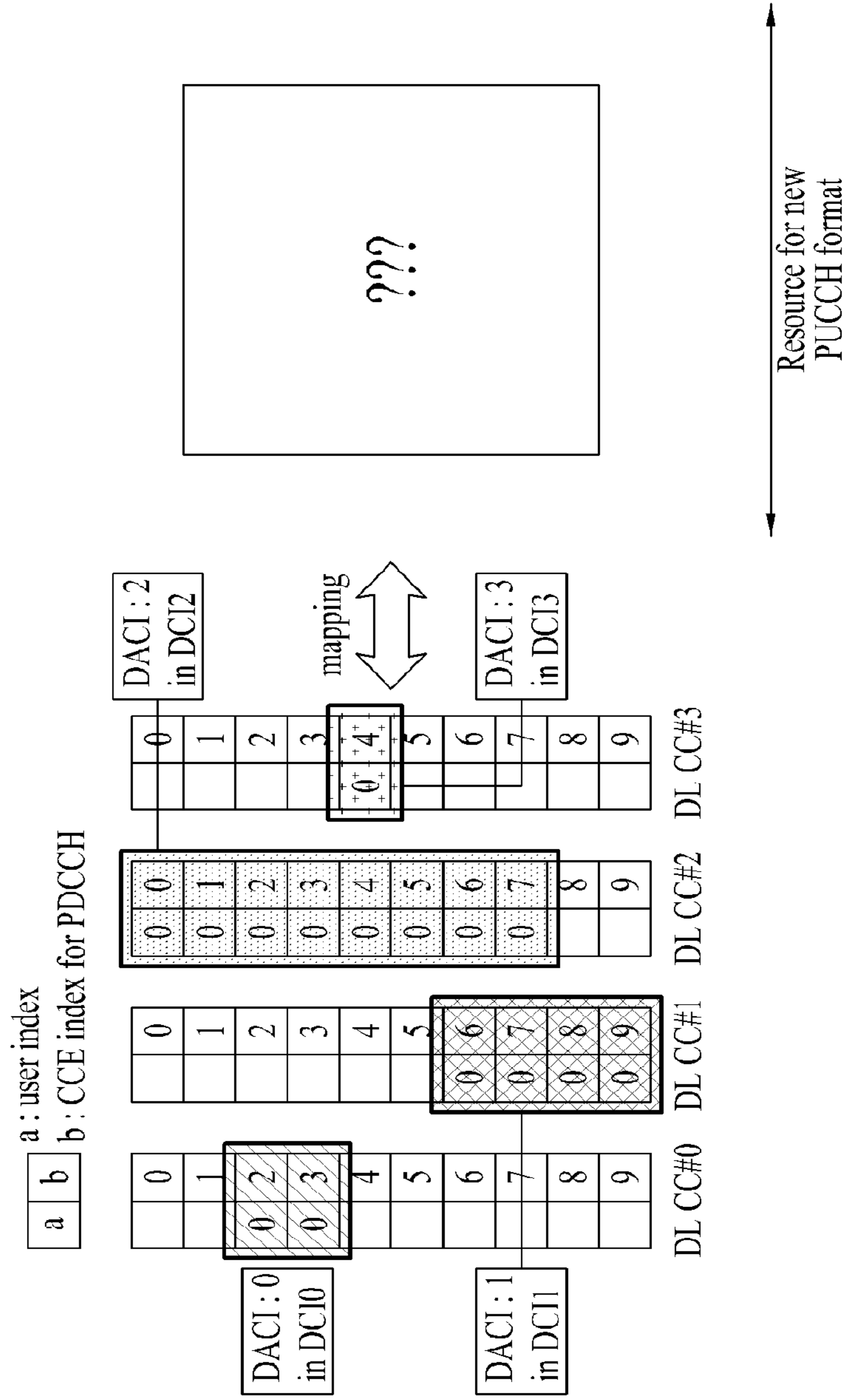

FIG. 46

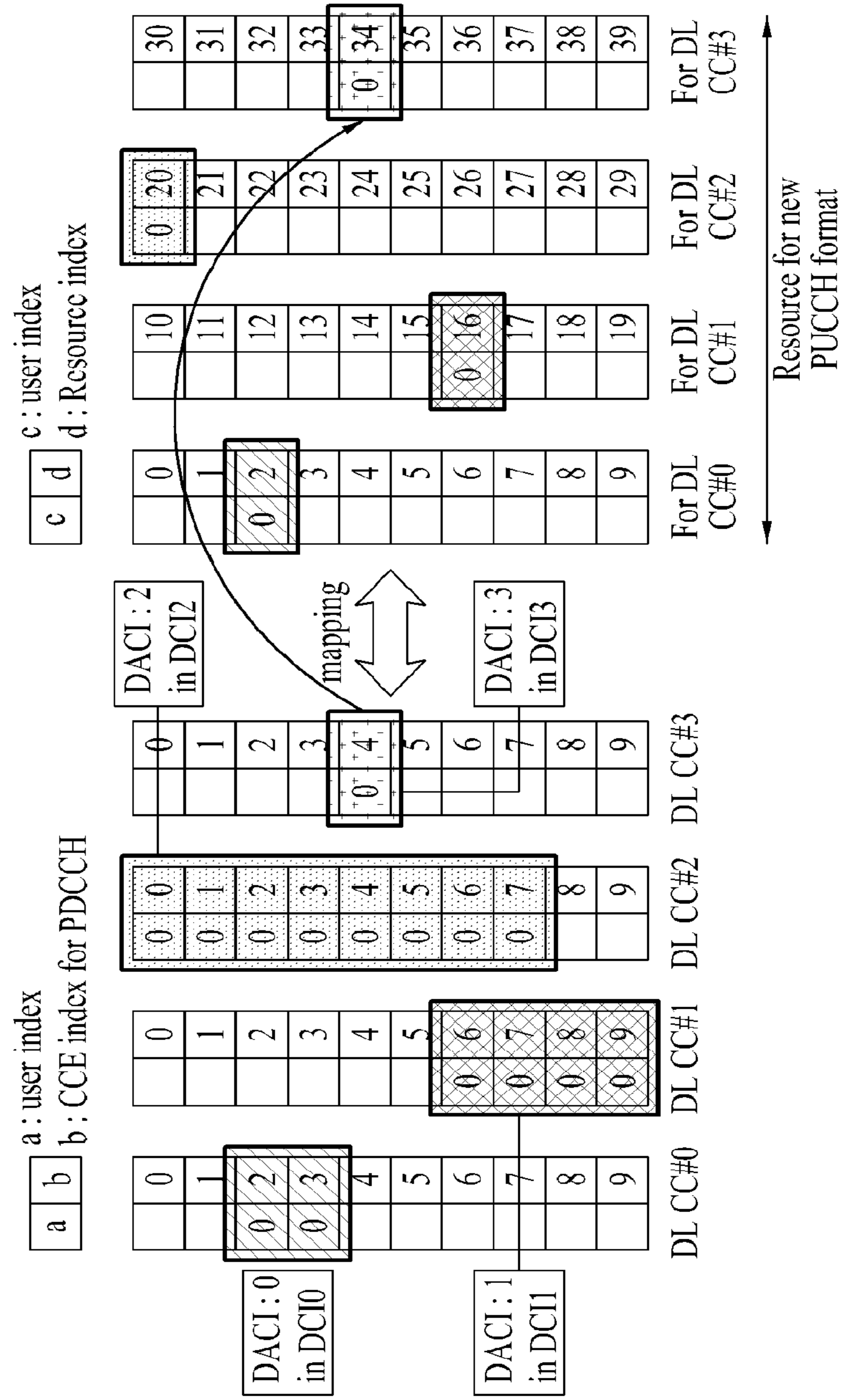

FIG. 47

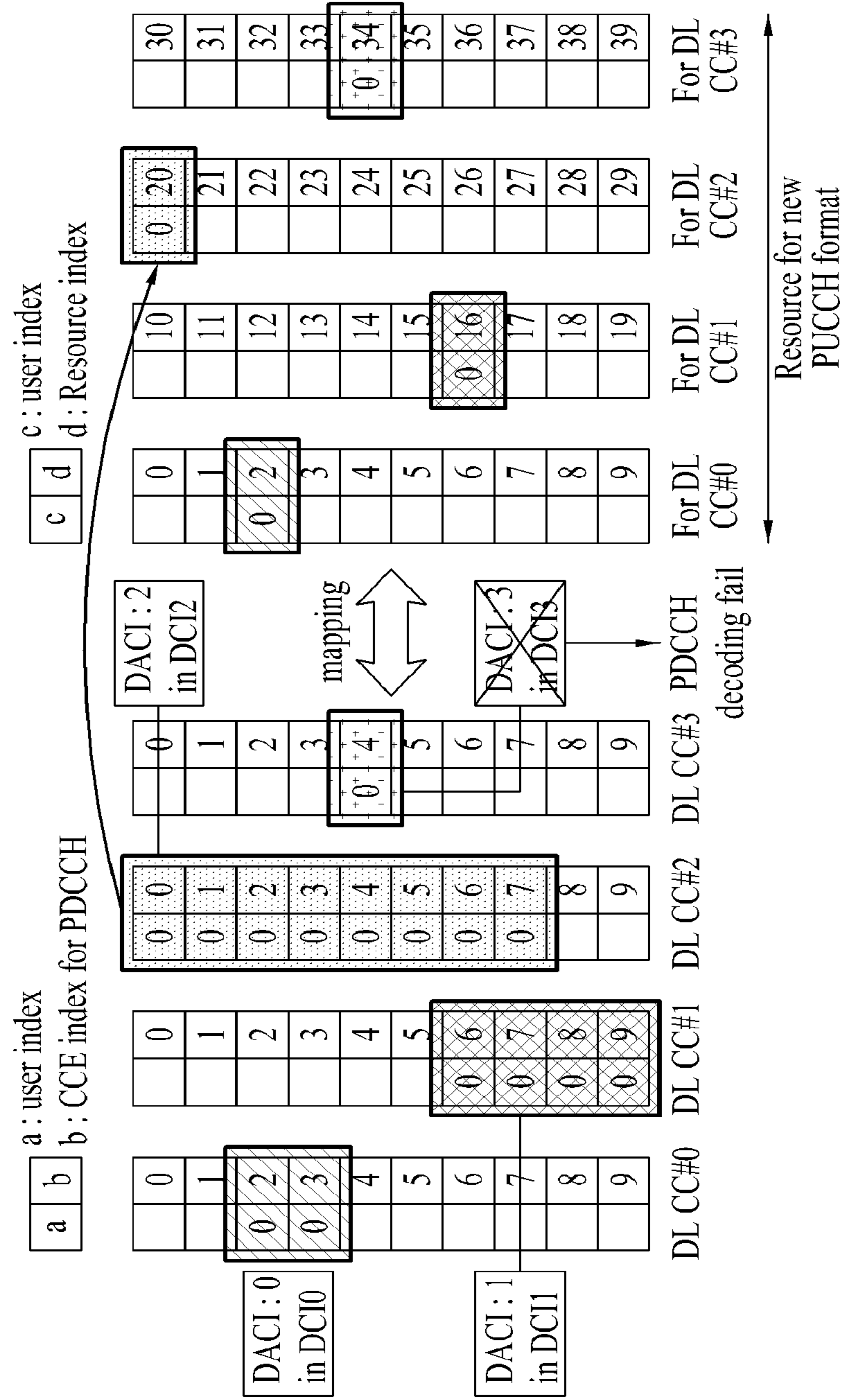

FIG. 48

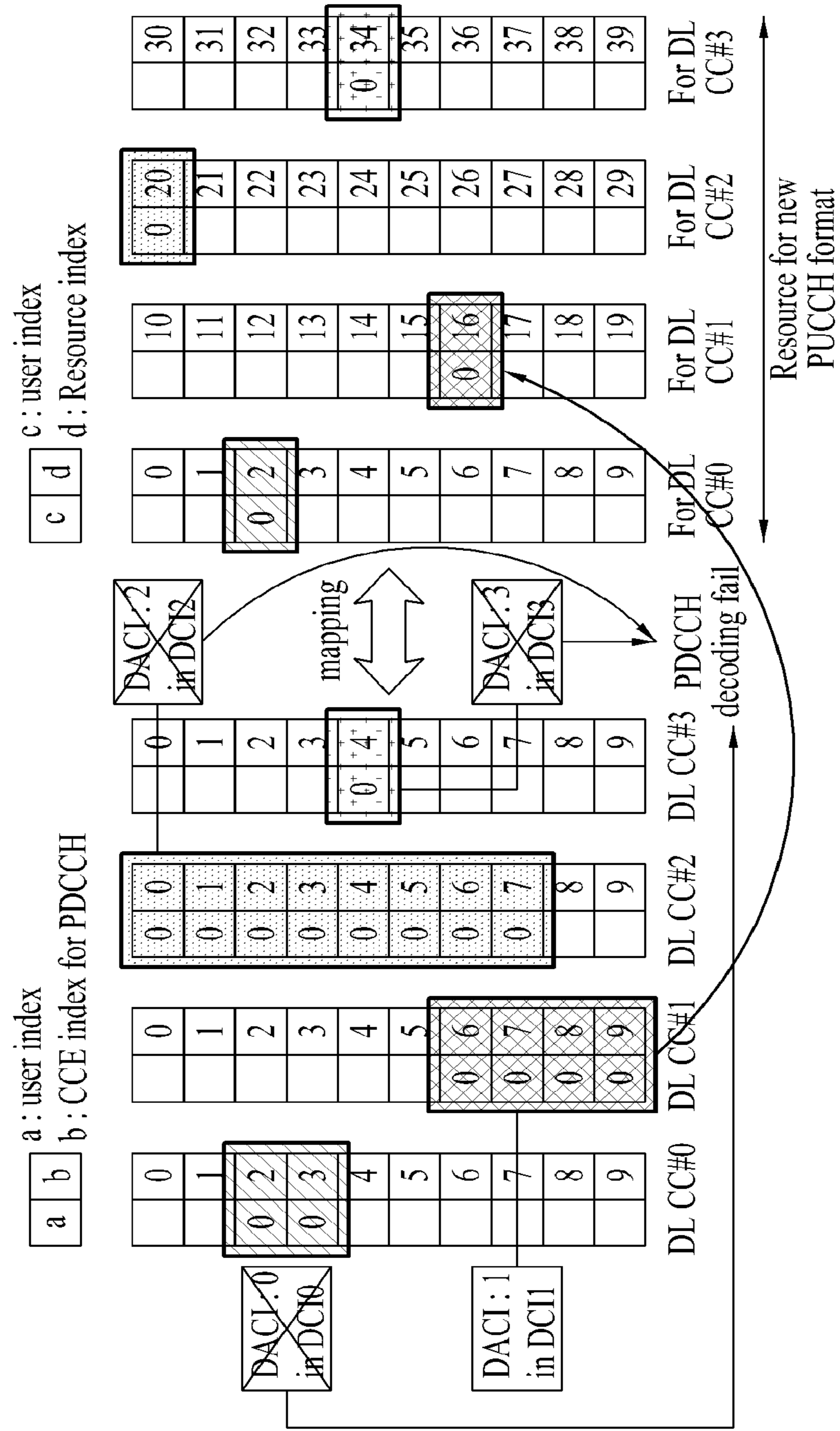

FIG. 49

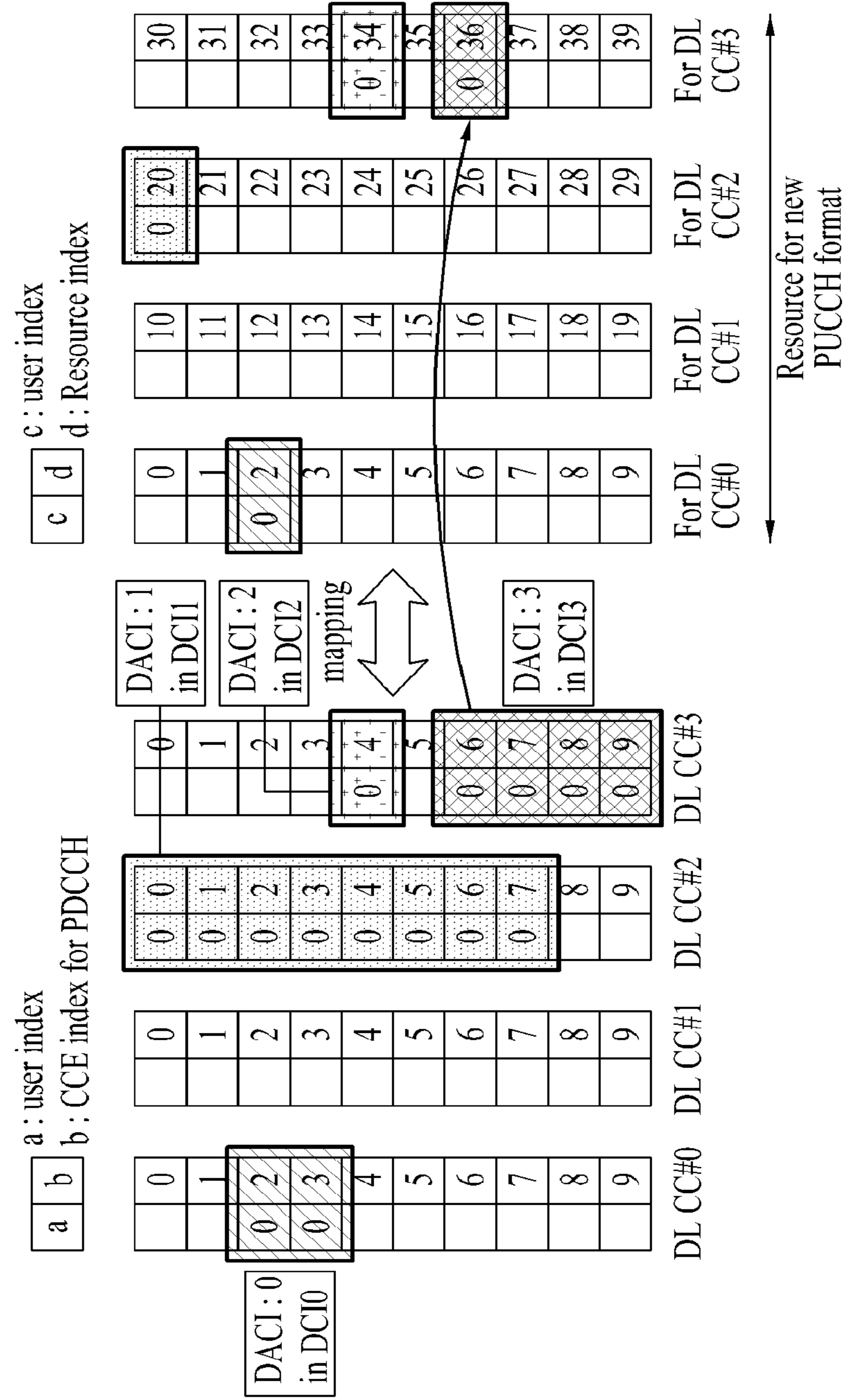

FIG. 50

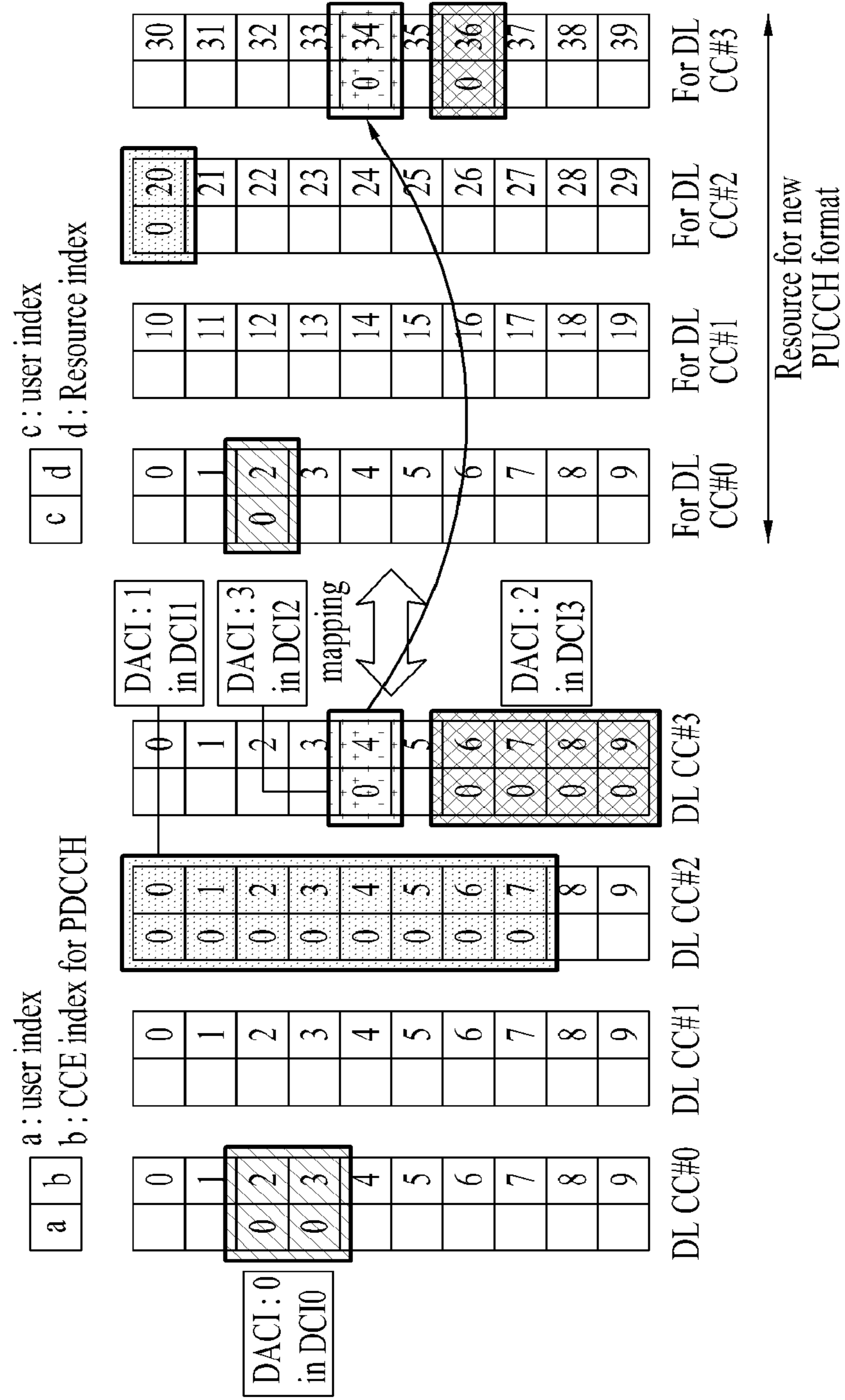

FIG. 51

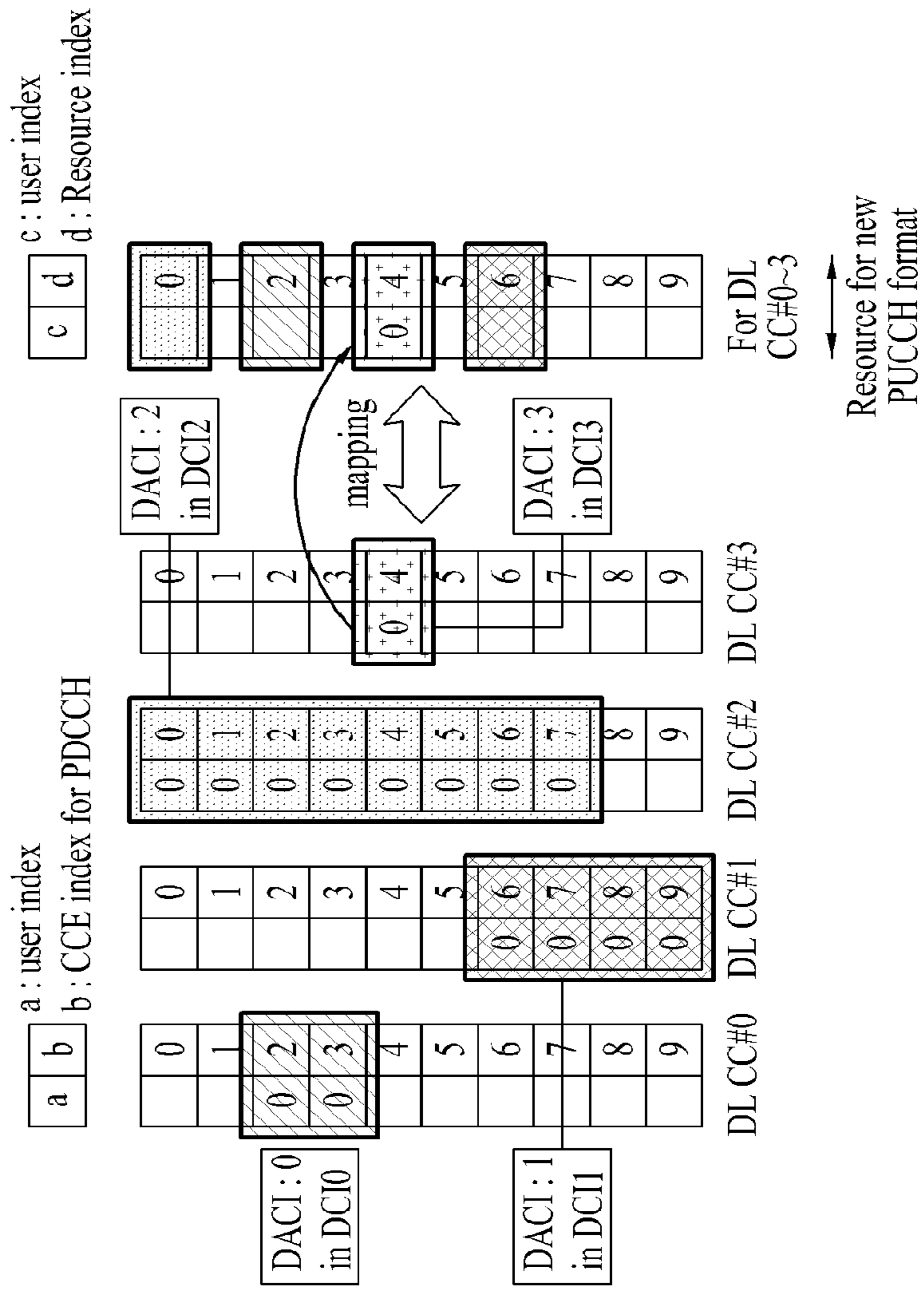

FIG. 52

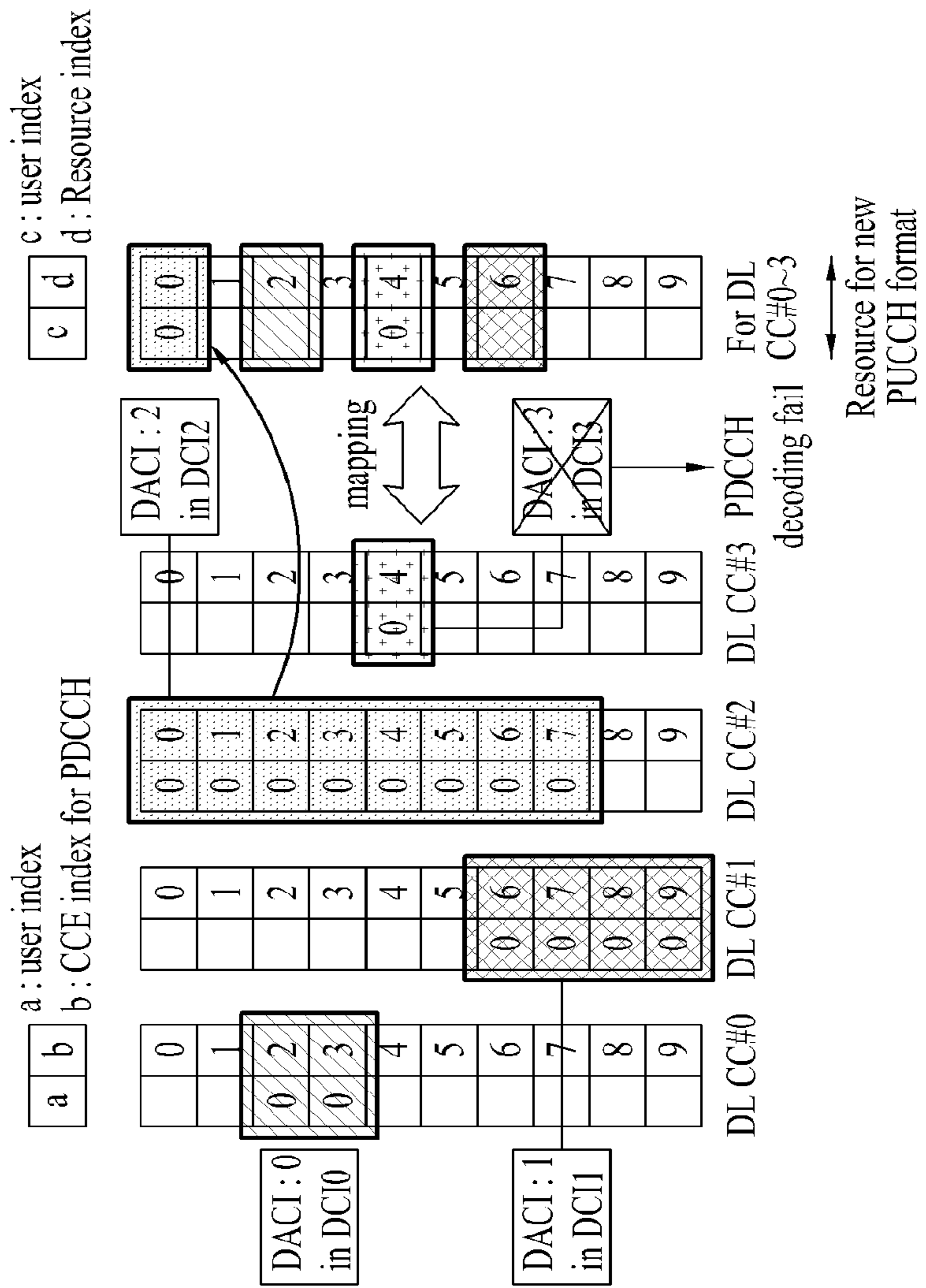

FIG. 53

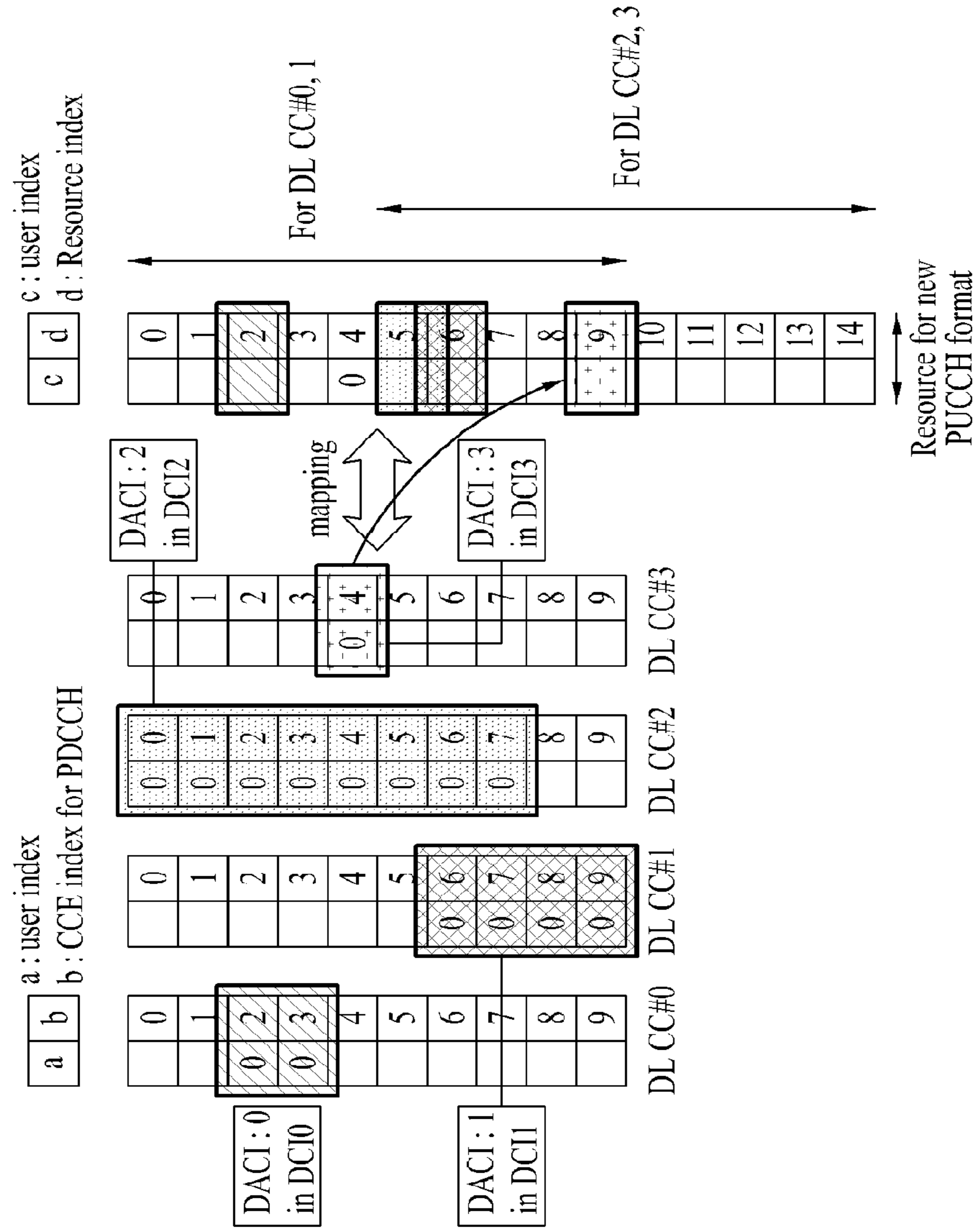

FIG. 54

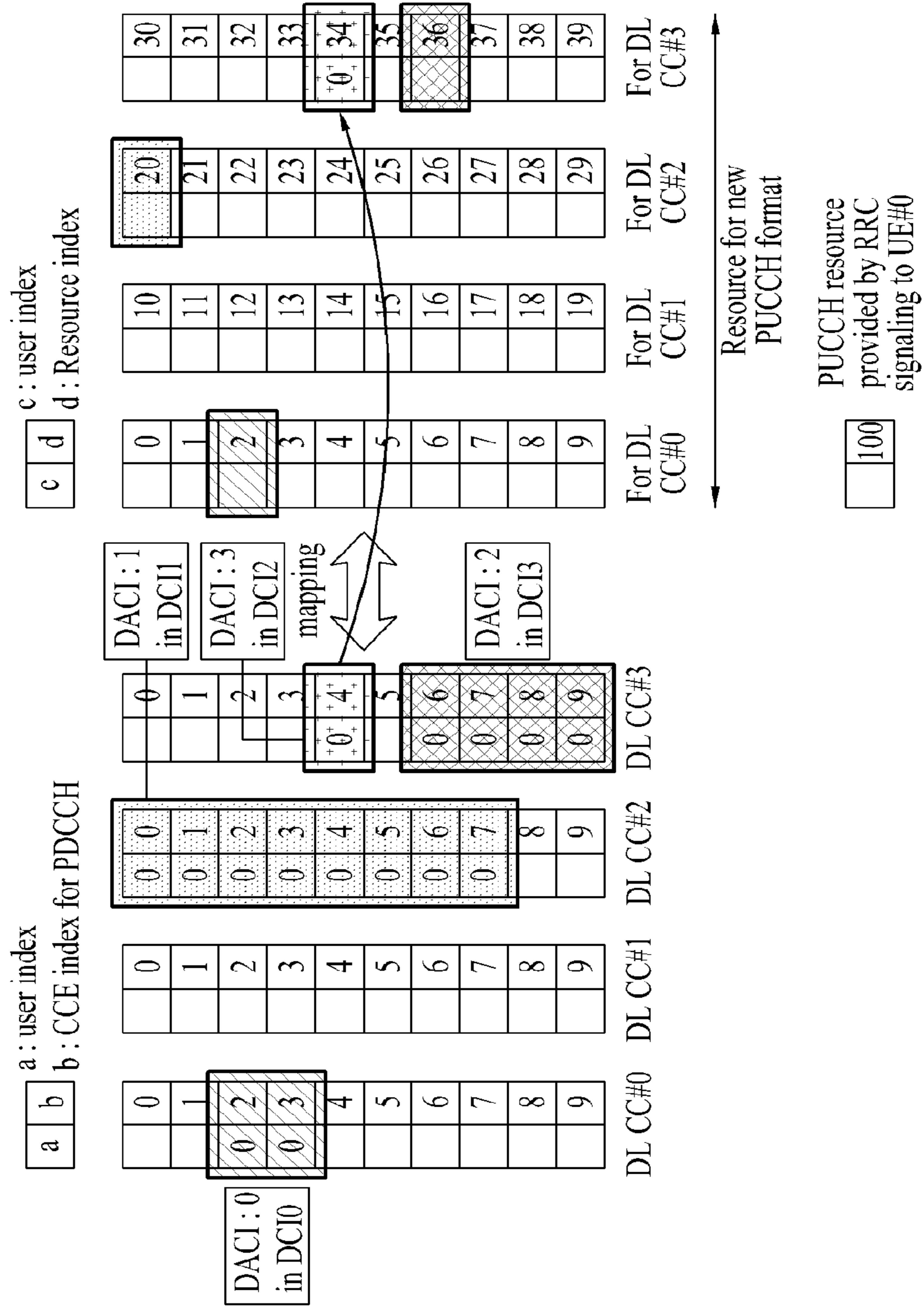

FIG. 55

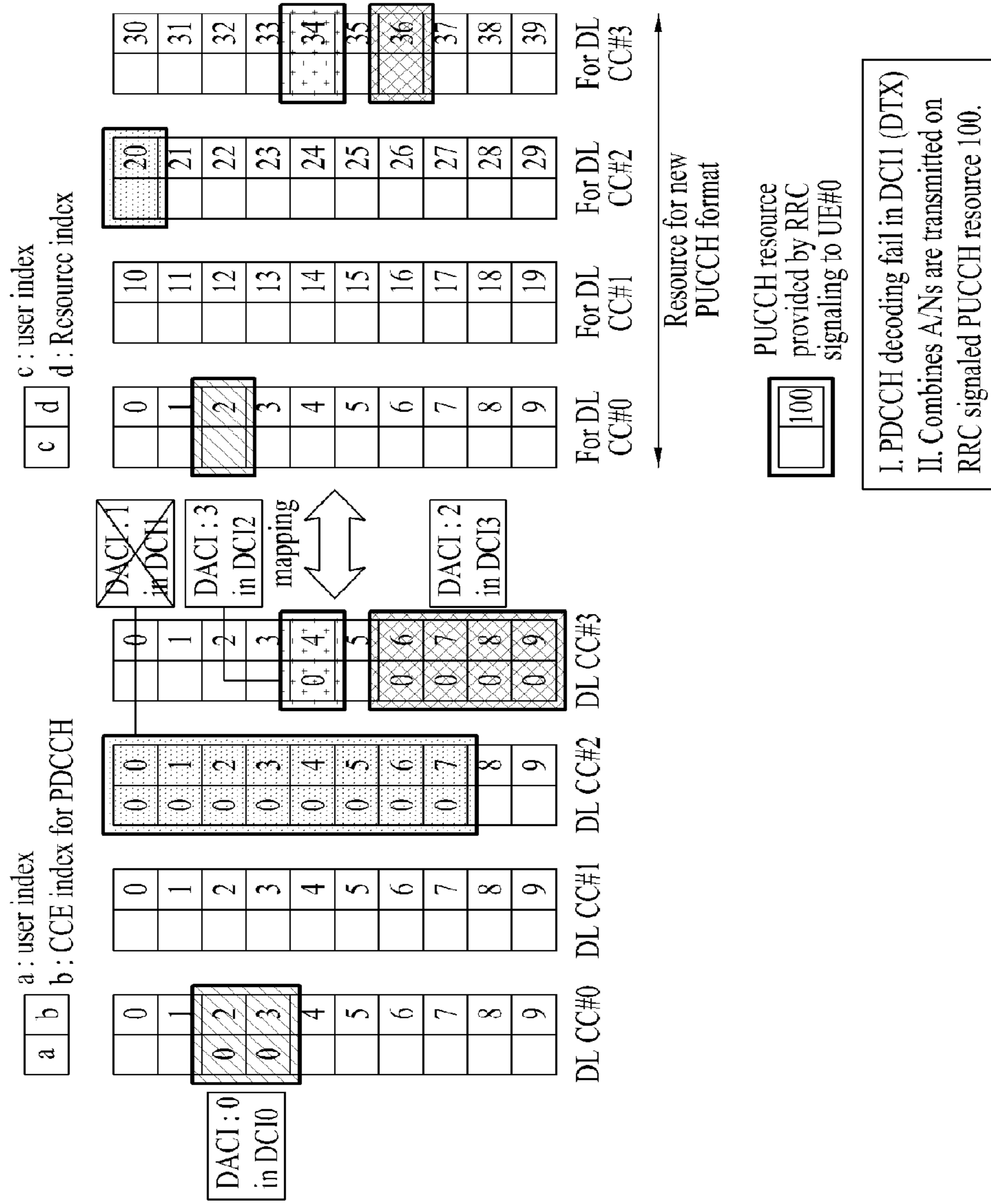
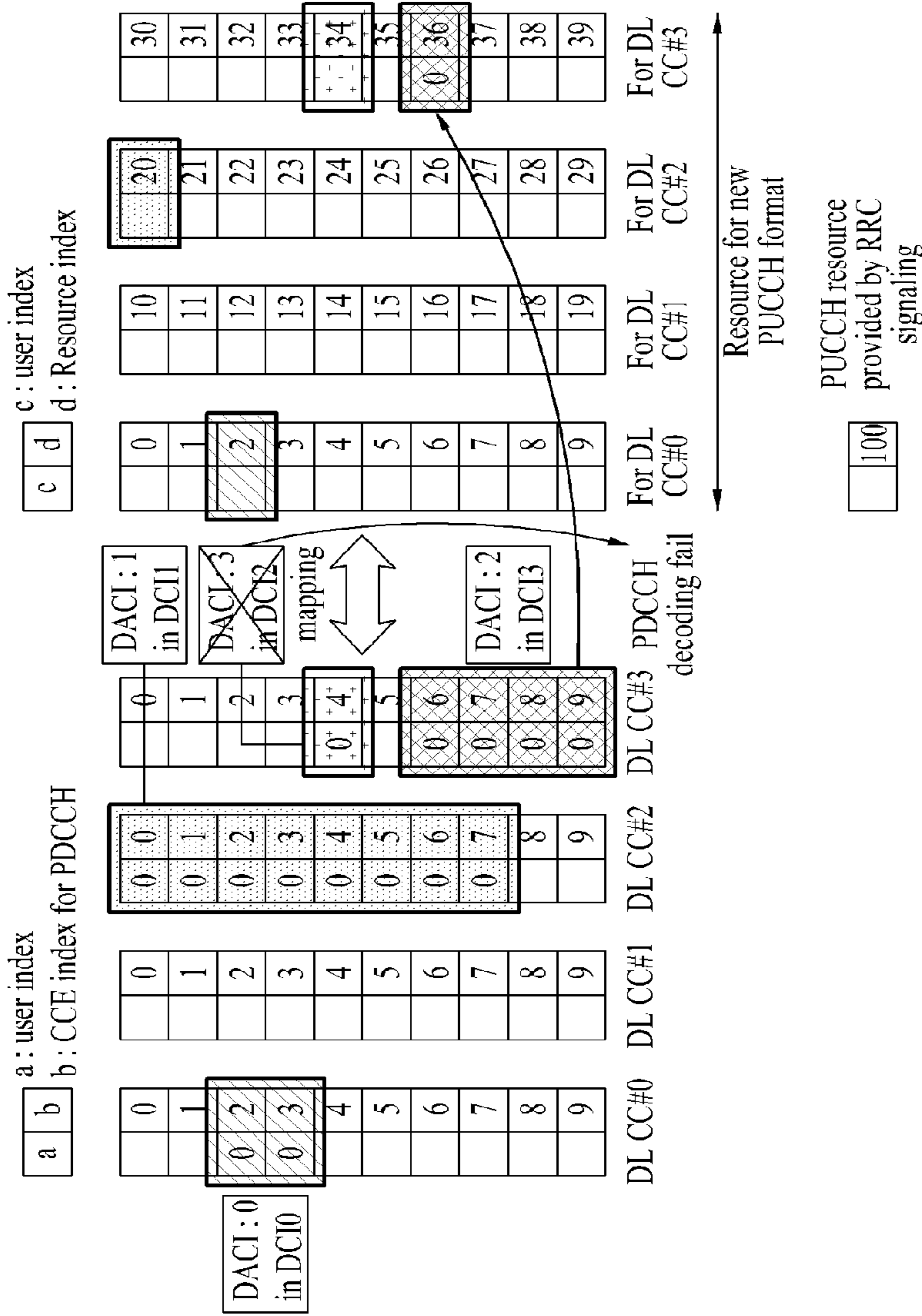
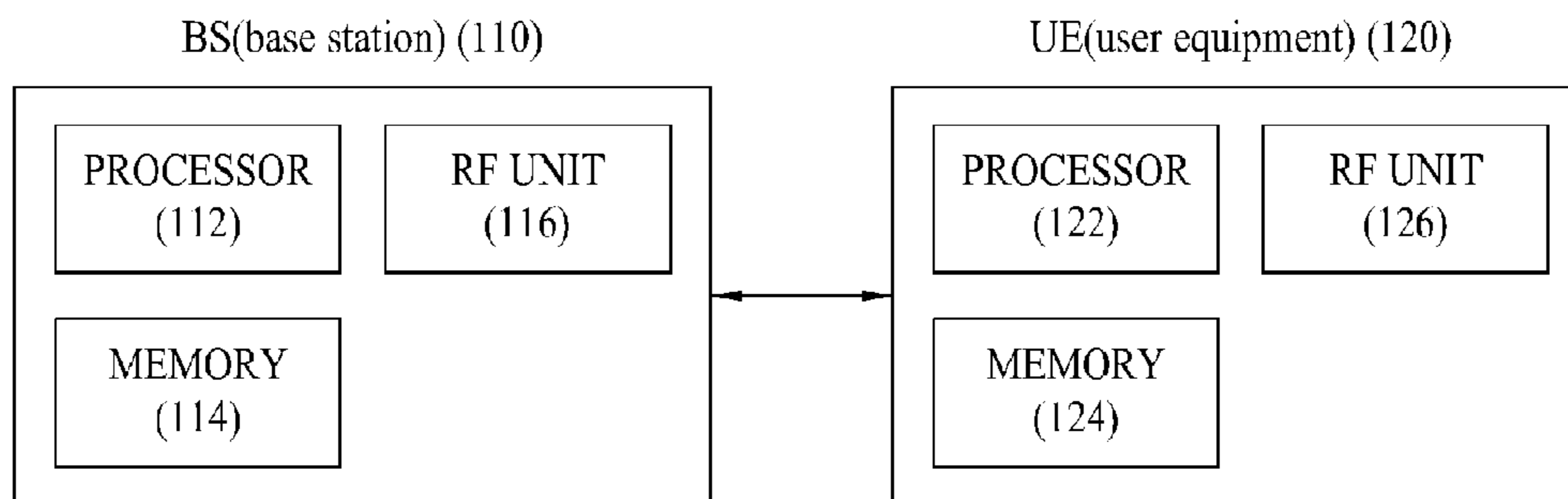

FIG. 56



- I. PDCCH decoding fail in DCI1 (DTX), but UE#0 cannot be aware of it.
- II. UE#0 transmits combined A/N on PUCCH resource 36 corresponding to DCI 3.
- III. The eNB can know that the UE transmits DTX for the DCI with largest value of DACI because eNB may expect the UCI on PUCCH resource 34 corresponding to DCI2 or RRC signaled PUCCH resource.

FIG. 57



**METHOD AND APPARATUS FOR
TRANSMITTING CONTROL INFORMATION
IN A WIRELESS COMMUNICATION
SYSTEM**

Matter enclosed in heavy brackets [] appears in the original patent but forms no part of this reissue specification; matter printed in italics indicates the additions made by reissue; a claim printed with strikethrough indicates that the claim was canceled, disclaimed, or held invalid by a prior post-patent action or proceeding.

This application is a reissue of U.S. Pat. No. 8,995,384 B2, which issued Mar. 31, 2015 from U.S. patent application Ser. No. 14/266,019, filed Apr. 30, 2014, which is a continuation of application Ser. No. 13/521,710 filed Jul. 11, 2012 which is now U.S. Pat. No. 8,767,661 issued Jul. 1, 2014, which claims the benefit of 35 USC §371 National Stage entry of International Application No. PCT/KR2011/000286 filed Jan. 14, 2011, which claims priority of Korean Application No. 10-2010-0129072 filed Dec. 16, 2010, and claims priority of U.S. Provisional Application No. 61/295,741 filed Jan. 17, 2010, 61/298,550 filed Jan. 27, 2010, 61/301,160 filed Feb. 3, 2010 and 61/311,740 filed Mar. 8, 2010, which are hereby incorporated by reference in its entirety.

TECHNICAL FIELD

The present invention relates to a wireless communication system and, more particularly, to a method and apparatus for transmitting control information. The wireless communication system can support carrier aggregation (CA).

BACKGROUND ART

Extensive research has been conducted to provide various types of communication services including voice and data services in wireless communication systems. In general, a wireless communication system is a multiple access system that supports communication with multiple users by sharing available system resources (e.g. bandwidth, transmission power, etc.) among the multiple users. The multiple access system may adopt a multiple access scheme such as Code Division Multiple Access (CDMA), Frequency Division Multiple Access (FDMA), Time Division Multiple Access (TDMA), Orthogonal Frequency Division Multiple Access (OFDMA), Single Carrier Frequency Division Multiple Access (SC-FDMA), etc.

DISCLOSURE

Technical Problem

An object of the present invention is to provide a method and apparatus for efficiently transmitting control information in a wireless communication system. Another object of the present invention is to provide a channel format, signal processing method and apparatus for efficiently transmitting control information. Another object of the present invention is to provide a method and apparatus for efficiently allocating resources for transmitting control information.

It will be appreciated by persons skilled in the art that the objects that could be achieved with the present invention are not limited to what have been particularly described hereinabove and the above and other objects that the present

invention could achieve will be more clearly understood from the following detailed description taken in conjunction with the accompanying drawings.

Technical Solution

The object of the present invention can be achieved by providing a method for transmitting control information through a physical uplink control channel (PUCCH) at a user equipment (UE) in a wireless communication system, the method including: joint-coding a plurality of control information to obtain a single codeword; obtaining a first modulation symbol sequence from the single codeword; spreading modulation symbols, corresponding to each slot in the PUCCH, in the first modulation symbol sequence so as to correspond to a plurality of single carrier-frequency division multiplexing (SC-FDMA) symbols in the corresponding slot to obtain a plurality of spread second modulation symbol sequences corresponding to the plurality of SC-FDMA symbols per each slot; and transmitting the plurality of spread second modulation symbol sequences through the corresponding SC-FDMA symbols in the PUCCH.

In another aspect of the present invention, there is provided a UE configured to transmit control information through a PUCCH in a wireless communication system, the UE including: a radio frequency (RF) unit; and a processor, wherein the processor is configured to joint-code a plurality of pieces of control information to obtain a single codeword, to obtain a first modulation symbol sequence from the single codeword, to spread modulation symbols, corresponding to each slot in the PUCCH, in the first modulation symbol sequence so as to correspond to a plurality of SC-FDMA symbols in the corresponding slot to obtain a plurality of spread second modulation symbol sequences corresponding to the plurality of SC-FDMA symbols per each slot, and to transmit the plurality of spread second modulation symbol sequences through the corresponding SC-FDMA symbols in the PUCCH.

Precoding for single carrier property may be applied to the plurality of spread second modulation symbol sequences on an SC-FDMA symbol basis.

The first half of the first modulation symbol sequence may be divided into a first slot and the second half thereof may be divided into a second slot.

A spreading code used for the spreading may be independently determined for each slot. In this case, the spreading code used for the spreading may be hopped on a slot basis.

Indexes of the SC-FDMA symbols, through which the plurality of spread second modulation symbol sequences are transmitted, in each slot are 0, 2, 3, 4 and 6 in a normal cyclic prefix (CP) case and 0, 1, 2, 4 and 5 in an extended CP case, and a spreading code used for the spreading is selected from orthogonal codes shown in the following table.

Index m	Orthogonal code SF = 5
0	[1 1 1 1 1]
1	[1 $e^{j2\pi/5}$ $e^{j4\pi/5}$ $e^{j6\pi/5}$ $e^{j8\pi/5}$]
2	[1 $e^{j4\pi/5}$ $e^{j8\pi/5}$ $e^{j2\pi/5}$ $e^{j6\pi/5}$]
3	[1 $e^{j6\pi/5}$ $e^{j2\pi/5}$ $e^{j8\pi/5}$ $e^{j4\pi/5}$]
4	[1 $e^{j8\pi/5}$ $e^{j6\pi/5}$ $e^{j4\pi/5}$ $e^{j2\pi/5}$]

The single codeword may be obtained by joint-coding multiple ACK (Acknowledgement)/NACK (Negative ACK) information for a plurality of downlink data.

According to embodiments of the present invention, control information can be efficiently transmitted in a wireless communication system. Furthermore, a channel format and a signal processing method for efficiently transmitting control information can be provided. In addition, resources for control information transmission can be efficiently allocated.

It will be appreciated by persons skilled in the art that the effects that could be achieved with the present invention are not limited to what has been particularly described hereinabove and these and other advantages of the present invention will be more clearly understood from the following detailed description taken in conjunction with the accompanying drawings.

DESCRIPTION OF DRAWINGS

The accompanying drawings, which are included to provide a further understanding of the invention and are incorporated in and constitute a part of this application, illustrate embodiment(s) of the invention and together with the description serve to explain the principle of the invention. In the drawings:

FIG. 1 illustrates physical channels used in a 3GPP LTE system and a signal transmission method using the same;

FIG. 2 illustrates an uplink signal processing procedure;

FIG. 3 illustrates a downlink signal processing procedure;

FIG. 4 illustrates SC-FDMA and OFDMA schemes;

FIG. 5 illustrates a signal mapping scheme in a frequency domain, which satisfies single carrier property;

FIG. 6 illustrates a signal processing procedure of mapping DFT process output samples to a single carrier in clustered SC-FDMA;

FIGS. 7 and 8 illustrate a signal processing procedure of mapping DFT process output samples to multiple carriers in clustered SC-FDMA;

FIG. 9 illustrates a signal processing procedure in segmented SC-FDMA;

FIG. 10 illustrates an uplink subframe structure;

FIG. 11 illustrates a signal processing procedure for transmitting a reference signal (RS) on uplink;

FIGS. 12A-12B illustrate a demodulation reference signal (DMRS) structure for a PUSCH;

FIGS. 13 and 14 illustrate slot level structures of PUCCH formats 1a and 1b;

FIGS. 15 and 16 illustrate slot level structures of PUCCH formats 2/2a/2b;

FIG. 17 illustrates ACK/NACK channelization for PUCCH formats 1a and 1b;

FIG. 18 illustrates channelization for a hybrid structure of PUCCH formats 1/1 a/1b and 2/2a/2b in the same PRB;

FIG. 19 illustrates PRB allocation for PUCCH transmission;

FIG. 20 illustrates a concept of management of downlink component carriers in a base station (BS);

FIG. 21 illustrates a concept of management of uplink component carriers in a user equipment (UE);

FIG. 22 illustrates a concept of management of multiple carriers by one MAC layer in a BS;

FIG. 23 illustrates a concept of management of multiple carriers by one MAC layer in a UE;

FIG. 24 illustrates a concept of management of multiple carriers by multiple MAC layers in a BS;

FIG. 25 illustrates a concept of management of multiple carriers by multiple MAC layers in a UE;

FIG. 26 illustrates a concept of management of multiple carriers by multiple MAC layers in a BS;

FIG. 27 illustrates a concept of management of multiple carriers by one or more MAC layers in a UE;

FIG. 28 illustrates asymmetrical carrier aggregation in which a plurality of DL CCs are linked to one UL CC;

FIGS. 29A-29F illustrate a PUCCH format and a signal processing procedure for the same according to an embodiment of the present invention;

FIG. 30 illustrates a PUCCH format and a signal processing procedure for the same according to an embodiment of the present invention;

FIGS. 31 to 34 illustrate a PUCCH format and a signal processing procedure for the same according to another embodiment of the present invention;

FIGS. 35A-35B illustrate PUCCH resources according to an embodiment of the present invention;

FIGS. 36A-36B illustrate PUCCH resources according to an embodiment of the present invention;

FIGS. 37A-37B illustrate PUCCH resources according to an embodiment of the present invention;

FIGS. 38A-38B illustrate PUCCH resources according to an embodiment of the present invention;

FIGS. 39A-39B illustrate PUCCH resources according to an embodiment of the present invention;

FIGS. 40A-40B illustrate PUCCH resources according to an embodiment of the present invention;

FIG. 41 illustrates PUCCH resources according to an embodiment of the present invention;

FIGS. 42A-42F illustrate PUCCH resources according to an embodiment of the present invention;

FIGS. 43A-43C illustrate a signal processing procedure for transmitting a PUCCH through multiple antennas according to an embodiment of the present invention;

FIG. 44 illustrates a PUCCH format and a signal processing procedure for the same according to another embodiment of the present invention;

FIGS. 45 to 56 illustrate PUCCH resource allocation according to an embodiment of the present invention; and

FIG. 57 illustrates configurations of a BS and a UE applicable to the present invention.

BEST MODE

Embodiments of the present invention are applicable to a variety of wireless access technologies such as Code Division Multiple Access (CDMA), Frequency Division Multiple Access (FDMA), Time Division Multiple Access (TDMA), Orthogonal Frequency Division Multiple Access (OFDMA), Single Carrier Frequency Division Multiple Access (SC-FDMA), etc. CDMA can be implemented as a wireless technology such as Universal Terrestrial Radio Access (UTRA) or CDMA2000. TDMA can be implemented as a wireless technology such as Global System for Mobile communications (GSM)/General Packet Radio Service (GPRS)/Enhanced Data Rates for GSM Evolution (EDGE). OFDMA can be implemented as a wireless technology such as Institute of Electrical and Electronics Engineers (IEEE) 802.11 (Wireless Fidelity (Wi-Fi)), IEEE 802.16 (Worldwide interoperability for Microwave Access (WiMAX)), IEEE 802.20, Evolved UTRA (E-UTRA). UTRA is a part of Universal Mobile Telecommunications System (UMTS). 3rd Generation Partnership Project (3GPP) Long Term Evolution (LTE) is a part of Evolved UMTS (E-UMTS) using E-UTRA. LTE-Advanced (LTE-A) is an evolution of 3GPP LTE. While the following description is given, centering on 3GPP LTE/LTE-A for clarity of descrip-

tion, this is purely exemplary and thus should not be construed as limiting the present invention.

In a wireless communication system, a UE receives information from a BS through downlink and transmits information to the BS through uplink. Information transmitted and received between the BS and the UE includes data and various types of control information. Various physical channels are present according to type/usage of information transmitted and received between the BS and the UE.

FIG. 1 illustrates physical channels used in a 3GPP LTE system and a signal transmission method using the same.

When powered on or when a UE initially enters a cell, the UE performs initial cell search involving synchronization with a BS in step S101. For initial cell search, the UE may be synchronized with the BS and acquire information such as a cell Identifier (ID) by receiving a Primary Synchronization Channel (P-SCH) and a Secondary Synchronization Channel (S-SCH) from the BS. Then the UE may receive broadcast information from the cell on a Physical Broadcast Channel (PBCH). In the mean time, the UE may determine a downlink channel status by receiving a Downlink Reference Signal (DL RS) during initial cell search.

After initial cell search, the UE may acquire more specific system information by receiving a Physical Downlink Control Channel (PDCCH) and receiving a Physical Downlink Shared Channel (PDSCH) based on information of the PDCCH in step S102.

The UE may perform a random access procedure to access the BS in steps S103 to S106. For random access, the UE may transmit a preamble to the BS on a Physical Random Access Channel (PRACH) (S103) and receive a response message for preamble on a PDCCH and a PDSCH corresponding to the PDCCH (S104). In the case of contention-based random access, the UE may perform a contention resolution procedure by further transmitting the PRACH (S105) and receiving a PDCCH and a PDSCH corresponding to the PDCCH (S106).

After the foregoing procedure, the UE may receive a PDCCH/PDSCH (S107) and transmit a Physical Uplink Shared Channel (PUSCH)/Physical Uplink Control Channel (PUCCH) (S108), as a general downlink/uplink signal transmission procedure. Here, control information transmitted from the UE to the BS is called uplink control information (UCI). The UCI may include a Hybrid Automatic Repeat and request Acknowledgement/Negative-ACK (HARQ ACK/NACK) signal, scheduling request (SR), a Channel Quality Indicator (CQI), a Precoding Matrix Index (PMI), a Rank Indication (RI), etc. While the UCI is transmitted through a PUCCH in general, it may be transmitted through a PUSCH when control information and traffic data need to be simultaneously transmitted. The UCI may be aperiodically transmitted through a PUSCH at the request/instruction of a network.

FIG. 2 illustrates a signal processing procedure through which a UE transmits an uplink signal.

To transmit the uplink signal, a scrambling module 210 of the UE may scramble the uplink signal using a UE-specific scramble signal. The scrambled signal is input to a modulation mapper 220 in which the scrambled signal is modulated into complex symbols using Binary Phase Shift Keying (BPSK), Quadrature Phase Shift Keying (QPSK) or 16-Quadrature amplitude Modulation (QAM)/64-QAM according to signal type and/or channel status. The modulated complex symbols are processed by a transform precoder 230, and then applied to a resource element mapper 240. The resource element mapper 240 may map the complex symbols to time-frequency resource elements. The

signal processed in this manner may be subjected to an SC-FDMA signal generator 250 and transmitted to a BS through an antenna.

FIG. 3 illustrates a signal processing procedure through which the BS transmits a downlink signal.

In a 3GPP LTE system, the BS may transmit one or more codewords on downlink. The codewords may be processed into complex symbols through a scrambling module 301 and a modulation mapper 302 as in the uplink shown in FIG. 2. Then, the complex symbols are mapped to a plurality of layers by a layer mapper 303. The layers may be multiplied by a precoding matrix in a precoding module 304 and allocated to transport antennas. The processed signals for the respective antennas may be mapped to time-frequency resource elements by a resource element mapper 305 and subjected to an OFDM signal generator 306 to be transmitted through the antennas.

When the UE transmits an uplink signal in a wireless communication system, a peak-to-average ratio (PAPR) becomes a problem, as compared to a case in which the BS transmits a downlink signal. Accordingly, uplink signal transmission uses SC-FDMA while downlink signal transmission uses OFDMA, as described above with reference to FIGS. 2 and 3.

FIG. 4 illustrates SC-FDMA and OFDMA schemes. The 3GPP system employs OFDMA in downlink and uses SC-FDMA in uplink.

Referring to FIG. 4, both a UE for transmitting an uplink signal and a BS for transmitting a downlink signal include a serial-to-parallel converter 401, a subcarrier mapper 403, an M-point IDFT module 404, and a cyclic prefix (CP) adder 406. The UE for transmitting a signal according to SC-FDMA additionally includes an N-point DFT module 402.

FIG. 5 illustrates a signal mapping scheme in a frequency domain, which satisfies single carrier property. FIG. 5(a) illustrates a localized mapping scheme and FIG. 5B illustrates a distributed mapping scheme.

Clustered SC-FDMA, which is a modified version of SC-FDMA, will now be described. Clustered SC-FDMA divides DFT process output samples into sub-groups in a subcarrier mapping process and discretely maps the sub-groups to the frequency domain (or subcarrier domain).

FIG. 6 illustrates a signal processing procedure for mapping DFT process output samples to a single carrier in clustered SC-FDMA. FIGS. 7 and 8 illustrate a signal processing procedure for mapping DFT process output samples to multiple carriers in clustered SC-FDMA. FIG. 6 shows an example of application of intra-carrier clustered SC-FDMA while FIGS. 7 and 8 show examples of application of inter-carrier clustered SC-FDMA. FIG. 7 illustrates a case in which a signal is generated through a single IFFT block when sub-carrier spacing between neighboring component carriers is set while component carriers are contiguously allocated in the frequency domain. FIG. 8 shows a case in which a signal is generated through a plurality of IFFT blocks when component carriers are non-contiguously allocated in the frequency domain.

FIG. 9 illustrates a signal processing procedure in segmented SC-FDMA.

Segmented SC-FDMA is a simple extension of the DFT spreading and IFFT subcarrier mapping structure of the conventional SC-FDMA, when the number of DFT blocks is equal to the number of IFFT blocks and thus the DFT blocks and the IFFT blocks are in one-to-one correspondence. While the term 'segmented SC-FDMA' is adopted herein, it may also be called NxSC-FDMA or Nx DFT spread OFDMA (Nx DFT-s-OFDMA). Referring to FIG. 9, the

segmented SC-FDMA is characterized in that total time-domain modulation symbols are divided into N groups (N is an integer larger than 1) and a DFT process is performed on a group-by-group basis to relieve the single carrier property constraint.

FIG. 10 illustrates an uplink subframe structure.

Referring to FIG. 10, an uplink subframe includes a plurality of slots (e.g. two slots). The slots may include different numbers of SC-FDMA symbols according to CP length. For example, the slot can include 7 SC-FDMA symbols in case of normal CP. The uplink subframe is divided into a data region and a control region. The data region includes a PUSCH and is used to transmit a data signal such as audio data. The control region includes a PUCCH and is used to transmit UCI. The PUCCH includes RB pairs (e.g. 7 RB pairs in frequency mirrored positions, and $m=0, 1, 2, 3, 4$) located on both ends of the data region in the frequency domain and is hopped based on slots. The UCI includes HARQ ACK/NACK, CQI, PMI, RI, etc.

FIG. 11 illustrates a signal processing procedure for transmitting a reference signal (RS) on uplink. While data is converted into a frequency domain signal through a DFT precoder, frequency-mapped, and then transmitted through IFFT, an RS does not pass the DFT precoder. Specifically, an RS sequence generated in the frequency domain (S11) is sequentially subjected to localization mapping (S12), IFFT (S13) and CP addition (S14) to be transmitted.

RS sequence $r_{u,v}^{(\alpha)}(n)$ is defined by cyclic shift α of a base sequence and may be represented by Equation 1.

$$r_{u,v}^{(\alpha)}(n) = e^{j\alpha n} \bar{r}_{u,v}(n), 0 \leq n < M_{sc}^{RS} \quad \text{[Equation 1]}$$

Here, $M_{sc}^{RS} = mN_{sc}^{RB}$ denotes the length of the RS sequence, N_{sc}^{RB} denotes a resource block size on a subcarrier basis, $1 \leq m \leq N_{RB}^{max,UL}$, and $N_{RB}^{max,UL}$ represents a maximum uplink transmission bandwidth.

Base sequence $\bar{r}_{u,v}(n)$ is divided into several groups. $u \in \{0, 1, \dots, 29\}$ denotes a group number and v corresponds to a base sequence number in a corresponding group. Each group includes one base sequence ($v=0$) having a length of $M_{sc}^{RS} = mN_{sc}^{RB}$ ($1 \leq m \leq 5$) and two base sequences ($v=0,1$) having a length of $M_{sc}^{RS} = mN_{sc}^{RB}$ ($6 \leq m \leq N_{RB}^{max,UL}$). The sequence group number u and base sequence number v in the corresponding group may vary with time. Base sequence $\bar{r}_{u,v}(0), \dots, \bar{r}_{u,v}(M_{sc}^{RS}-1)$ is defined according to sequence length M_{sc}^{RS} .

A base sequence having a length of longer than $3N_{sc}^{RB}$ can be defined as follows.

For $M_{sc}^{RS} \geq 3N_{sc}^{RB}$, base sequence $\bar{r}_{u,v}(0), \dots, \bar{r}_{u,v}(M_{sc}^{RS}-1)$ is given by the following Equation 2.

$$\bar{r}_{u,v}(n) = x_q(n \bmod N_{zc}^{RS}), 0 \leq n < M_{sc}^{RS} \quad \text{[Equation 2]}$$

Here, the q -th root Zadoff-Chu sequence can be defined by the following Equation 3.

$$x_q(m) = e^{-j \frac{\pi q m(m+1)}{N_{zc}^{RS}}}, 0 \leq m \leq N_{zc}^{RS} - 1 \quad \text{[Equation 3]}$$

Here, q satisfies the following Equation 4.

$$q = \lfloor \bar{q} + 1/2 \rfloor + v \cdot (-1)^{\lfloor 2\bar{q} \rfloor} \quad \text{[Equation 4]}$$

$$\bar{q} = N_{zc}^{RS} \cdot (u+1) / 31$$

The length N_{zc}^{RS} of the Zadoff-Chu sequence is given by the largest prime number, and thus $N_{zc}^{RS} < M_{sc}^{RS}$ is satisfied.

A base sequence having a length of less than $3N_{sc}^{RB}$ can be defined as follows. The base sequence is given by the following Equation 5 for $M_{sc}^{RS} = N_{sc}^{RB}$ and $M_{sc}^{RS} = 2N_{sc}^{RB}$.

$$\bar{r}_{u,v}(n) = e^{j\phi(n)\pi/4}, 0 \leq n \leq M_{sc}^{RS} - 1 \quad \text{[Equation 5]}$$

Here, for $M_{sc}^{RS} = N_{sc}^{RB}$ and $M_{sc}^{RS} = 2N_{sc}^{RB}$, $\phi(n)$ is given as shown in Tables 1 and 2, respectively.

TABLE 1

u	$\phi(0), \dots, \phi(11)$											
0	-1	1	3	-3	3	3	1	1	3	1	-3	3
1	1	1	3	3	3	-1	1	-3	-3	1	-3	3
2	1	1	-3	-3	-3	-1	-3	-3	1	-3	1	-1
3	-1	1	1	1	1	-1	-3	-3	1	-3	3	-1
4	-1	3	1	-1	1	-1	-3	-1	1	-1	1	3
5	1	-3	3	-1	-1	1	1	-1	-1	3	-3	1
6	-1	3	-3	-3	-3	3	1	-1	3	3	-3	1
7	-3	-1	-1	-1	1	-3	3	-1	1	-3	3	1
8	1	-3	3	1	-1	-1	-1	1	1	3	-1	1
9	1	-3	-1	3	3	-1	-3	1	1	1	1	1
10	-1	3	-1	1	1	-3	-3	-1	-3	-3	3	-1
11	3	1	-1	-1	3	3	-3	1	3	1	3	3
12	1	-3	1	1	-3	1	1	1	-3	-3	-3	1
13	3	3	-3	3	-3	1	1	3	-1	-3	3	3
14	-3	1	-1	-3	-1	3	1	3	3	3	-1	1
15	3	-1	1	-3	-1	-1	1	1	3	1	-1	-3
16	1	3	1	-1	1	3	3	3	-1	-1	3	-1
17	-3	1	1	3	-3	3	-3	-3	3	1	3	-1
18	-3	3	1	1	-3	1	-3	-3	-1	-1	1	-3
19	-1	3	1	3	1	-1	-1	3	-3	-1	-3	-1
20	-1	-3	1	1	1	1	3	1	-1	1	-3	-1
21	-1	3	-1	1	-3	-3	-3	-3	-3	1	-1	-3
22	1	1	-3	-3	-3	-3	-1	3	-3	1	-3	3
23	1	1	-1	-3	-1	-3	1	-1	1	3	-1	1
24	1	1	3	1	3	3	-1	1	-1	-3	-3	1
25	1	-3	3	3	1	3	3	1	-3	-1	-1	3
26	1	3	-3	-3	3	-3	1	-1	-1	3	-1	-3
27	-3	-1	-3	-1	-3	3	1	-1	1	3	-3	-3
28	-1	3	-3	3	-1	3	3	-3	3	3	-1	-1
29	3	-3	-3	-1	-1	-3	-1	3	-3	3	1	-1

TABLE 2

u	$\phi(0), \dots, \phi(23)$																							
0	-1	3	1	-3	3	-1	1	3	-3	3	1	3	-3	3	1	-1	1	3	-3	3	-3	-1	-3	
1	-3	3	-3	-3	-3	1	-3	-3	3	-1	1	1	1	3	1	-1	3	-3	-3	1	3	1	1	-3
2	3	-1	3	3	1	1	-3	3	3	3	3	1	-1	3	-1	1	1	-1	-3	-1	-1	1	3	3
3	-1	-3	1	1	3	-3	1	1	-3	-1	-1	1	3	1	3	1	-1	3	1	1	-3	-1	-3	-1
4	-1	-1	-1	-3	-3	-1	1	1	3	3	-1	3	-1	1	-1	-3	1	-1	-3	-3	1	-3	-1	-1
5	-3	1	1	3	-1	1	3	1	-3	1	-3	1	1	-1	-1	3	-1	-3	3	-3	-3	-3	1	1
6	1	1	-1	-1	3	-3	-3	3	-3	1	-1	-1	1	-1	1	1	-1	-3	-1	1	-1	3	-1	-3
7	-3	3	3	-1	-1	-3	-1	3	1	3	1	3	1	1	-1	3	1	-1	1	3	-3	-1	-1	1
8	-3	1	3	-3	1	-1	-3	3	-3	3	-1	-1	-1	-1	1	-3	-3	-3	1	-3	-3	-3	1	-3
9	1	1	-3	3	3	-1	-3	-1	3	-3	3	3	3	-1	1	1	-3	1	-1	1	1	-3	1	1
10	-1	1	-3	-3	3	-1	3	-1	-1	-3	-3	-3	-1	-3	-3	1	-1	1	3	3	-1	1	-1	3

TABLE 2-continued

u	$\phi(0), \dots, \phi(23)$																							
11	1	3	3	-3	-3	1	3	1	-1	-3	-3	-3	3	3	-3	3	3	-1	-3	3	-1	1	-3	1
12	1	3	3	1	1	1	-1	-1	1	-3	3	-1	1	1	-3	3	3	-1	-3	3	-3	-1	-3	-1
13	3	-1	-1	-1	-1	-3	-1	3	3	1	-1	1	3	3	3	-1	1	1	-3	1	3	-1	-3	3
14	-3	-3	3	1	3	1	-3	3	1	3	1	1	3	3	-1	-1	-3	1	-3	-1	3	1	1	3
15	-1	-1	1	-3	1	3	-3	1	-1	-3	-1	3	1	3	1	-1	-3	-3	-1	-1	-3	-3	-3	1
16	-1	-3	3	-1	-1	-1	-1	1	1	-3	3	1	3	3	1	-1	1	-3	1	-3	1	1	-3	-1
17	1	3	-1	3	3	-1	-3	1	-1	-3	3	3	3	-1	1	1	3	-1	-3	-1	3	-1	-1	-1
18	1	1	1	1	1	-1	3	-1	-3	1	1	3	-3	1	-3	-1	1	1	-3	-3	3	1	1	-3
19	1	3	3	1	-1	-3	3	-1	3	3	3	-3	1	-1	1	-1	-3	-1	1	3	-1	3	-3	-3
20	-1	-3	3	-3	-3	-3	-1	-1	-3	-1	-3	3	1	3	-3	-1	3	-1	1	-1	3	-3	1	-1
21	-3	-3	1	1	-1	1	-1	1	-1	3	1	-3	-1	1	-1	1	-1	-1	3	3	-3	-1	1	-3
22	-3	-1	-3	3	1	-1	-3	-1	-3	-3	3	-3	3	-3	-1	1	3	1	-3	1	3	3	-1	-3
23	-1	-1	-1	-1	3	3	3	1	3	3	-3	1	3	-1	3	-1	3	3	-3	3	1	-1	3	3
24	1	-1	3	3	-1	-3	3	-3	-1	-1	3	-1	3	-1	-1	1	1	1	-1	-1	-3	-1	3	3
25	1	-1	1	-1	3	-1	3	1	1	-1	-1	-3	1	1	-3	1	3	-3	1	1	-3	-3	-1	-1
26	-3	-1	1	3	1	1	-3	-1	-1	-3	3	-3	3	1	-3	3	-3	1	-1	1	-3	1	1	1
27	-1	-3	3	3	1	1	3	-1	-3	-1	-1	-1	3	1	-3	-3	-1	3	-3	-1	-3	-1	-3	-1
28	-1	-3	-1	-1	1	-3	-1	-1	1	-1	-3	1	1	-3	1	-3	-3	3	1	1	-1	3	-1	-1
29	1	1	-1	-1	-3	-1	3	-1	3	-1	1	3	1	-1	3	1	3	-3	-3	1	-1	-1	1	3

RS hopping will now be described.

The sequence group number u in slot n_s can be defined by group hopping pattern $f_{gh}(n_s)$ and a sequence-shift pattern f_{ss} according to Equation 6.

$$u = (f_{gh}(n_s) + f_{ss}) \bmod 30 \quad \text{[Equation 6]}$$

Here, mod denotes a modulo operation.

There are 17 different hopping patterns and 30 different sequence-shift patterns. Sequence group hopping may be enabled or disabled by means of a parameter that enables group hopping and is provided by higher layers.

PUCCH and PUSCH have the same hopping pattern but may have different sequence-shift patterns.

The group hopping pattern $f_{gh}(n_s)$ is the same for PUSCH and PUCCH and given by the following Equation 7.

$$f_{gh}(n_s) = \begin{cases} 0 & \text{if group hopping is disabled} \\ \left(\sum_{i=0}^7 c(8n_s + i) \cdot 2^i \right) \bmod 30 & \text{if group hopping is enable} \end{cases} \quad \text{[Equation 7]}$$

Here, $c(i)$ corresponds to a pseudo-random sequence and the pseudo-random sequence generator may be initialized with

$$c_{init} = \left\lfloor \frac{N_{ID}^{cell}}{30} \right\rfloor$$

at the beginning of each radio frame.

Sequence-shift pattern f_{ss} differs between PUCCH and PUSCH.

For PUCCH, sequence-shift pattern f_{ss}^{PUCCH} is given by $f_{ss}^{PUCCH} = N_{ID}^{cell} \bmod 30$. For PUSCH, sequence shift pattern f_{ss}^{PUSCH} is given by $f_{ss}^{PUSCH} = (f_{ss}^{PUCCH} + \Delta_{ss}) \bmod 30$. $\Delta_{ss} \in \{0, 1, \dots, 29\}$ is configured by higher layers.

Sequence hopping will now be described.

Sequence hopping only applies for reference signals of length $M_{sc}^{RS} \geq 6N_{sc}^{RB}$.

For reference signals of length $M_{sc}^{RS} < 6N_{sc}^{RB}$, the base sequence number v within the base sequence group is given by $v=0$.

For reference signals of length $M_{sc}^{RS} \geq 6N_{sc}^{RB}$, the base sequence number v within the base sequence group in slot n_s is given by the following Equation 8.

$$v = \begin{cases} c(n_s) & \text{if group hopping is disabled and} \\ & \text{sequence hopping is enabled} \\ 0 & \text{otherwise} \end{cases} \quad \text{[Equation 8]}$$

Here, $c(i)$ corresponds to the pseudo-random sequence and a parameter that is provided by higher layers and enables sequence hopping determines if sequence hopping is enabled or not. The pseudo-random sequence generator may be initialized with

$$c_{init} = \left\lfloor \frac{N_{ID}^{cell}}{30} \right\rfloor \cdot 2^5 + f_{ss}^{PUSCH}$$

at the beginning of each radio frame.

A reference signal for PUSCH is determined as follows.

Reference signal sequence $r^{PUSCH}(\cdot)$ for PUSCH is defined by $r^{PUSCH}(m \cdot M_{sc}^{RS} + n) = r_{u,v}^{(\alpha)}(n)$ where

$$m = 0, 1$$

$$n = 0, \dots, M_{sc}^{RS} - 1$$

and $M_{sc}^{RS} = M_{sc}^{PUSCH}$.

A cyclic shift is given by $\alpha = 2 \cdot n_{cs} / 12$ and $n_{cs} = (n_{DMRS}^{(1)} + n_{DMRS}^{(2)+n_{PRS}(n_s)}) \bmod 12$ in one slot.

Here, $n_{DMRS}^{(1)}$ is a broadcast value, $n_{DMRS}^{(2)}$ is given by uplink scheduling allocation, and $n_{PRS}(n_s)$ is a cell-specific cyclic shift value. $n_{PRS}(n_s)$ varies with slot number n_s and is given by $n_{PRS}(n_s) = \sum_{i=0}^7 c(8n_s + i) \cdot 2^i$.

Here, $c(i)$ denotes the pseudo-random sequence and is a cell-specific value. The pseudo-random sequence generator may be initialized with

$$c_{init} = \left\lfloor \frac{N_{ID}^{cell}}{30} \right\rfloor \cdot 2^5 + f_{ss}^{PUSCH}$$

at the beginning of each radio frame.

11

Table 3 shows a cyclic shift field and $n_{DMRS}^{(2)}$ in downlink control information (DCI) format 0.

TABLE 3

Cyclic shift field in DCI format 0	$n_{DMRS}^{(2)}$
000	0
001	2
010	3
011	4
100	6
101	8
110	9
111	10

A physical mapping method for an uplink RS in a PUSCH will now be described.

The sequence is multiplied with the amplitude scaling factor β_{PUSCH} and mapped to the same set of a physical resource block (PRB) used for the corresponding PUSCH in a sequence starting with $r^{PUSCH}(0)$. Mapping to resource elements (k,l), with $l=3$ for normal CP and $l=2$ for extended CP, in the subframe will be in increasing order of first k, then the slot number.

In summary, a ZC sequence is used with cyclic extension for length $3N_{sc}^{RB}$ or larger, whereas a computer generated sequence is used for length less than $3N_{sc}^{RB}$. A cyclic shift is determined according to cell-specific cyclic shift, UE-specific cyclic shift and hopping pattern.

FIG. 12a shows a DMRS structure for PUSCH in case of normal CP and FIG. 12b shows a DMRS structure for PUSCH in case of extended CP. A DMRS is transmitted through the fourth and eleventh SC-FDMA symbols in FIG. 12a and transmitted through the third and ninth SC-FDMA symbols in FIG. 12b.

FIGS. 13 to 16 illustrate slot level structures of PUCCH formats. A PUCCH has the following formats in order to transmit control information.

(1) Format 1: on-off keying (OOK) modulation, used for scheduling request (SR).

(2) Formats 1a and 1b: used for ACK/NACK transmission.

1) Format 1a: BPSK ACK/NACK for one codeword

2) Format 1b: QPSK ACK/NACK for two codewords

(3) Format 2: QPSK modulation, used for CQI transmission.

(4) Formats 2a and 2b: used for simultaneous transmission of CQI and ACK/NACK

Table 4 shows modulation schemes according to PUCCH format and the number of bits per subframe. Table 5 shows the number of RSs per slot according to PUCCH format and Table 6 shows SC-FDMA symbol position in an RS according to PUCCH format. In Table 4, PUCCH formats 2a and 2b correspond to normal CP.

TABLE 4

PUCCH format	Modulation scheme	Number of bits per subframe (M_{bit})
1	N/A	N/A
1a	BPSK	1
1b	QPSK	2
2	QPSK	20
2a	QPSK + BPSK	21
2b	QPSK + BPSK	22

12

TABLE 5

PUCCH format	Normal CP	Extended CP
1, 1a, 1b	3	2
2	2	1
2a, 2b	2	N/A

TABLE 6

PUCCH format	SC-FDMA symbol position in RS	
	Normal CP	Extended CP
1, 1a, 1b	2, 3, 4	2, 3
2, 2a, 2b	1, 5	3

FIG. 13 illustrates PUCCH formats 1a and 1b in case of normal CP and FIG. 14 illustrates PUCCH formats 1a and 1b in case of extended CP. In PUCCH formats 1a and 1b, the same control information is repeated in a subframe on a slot-by-slot basis. ACK/NACK signals are respectively transmitted from UEs through different resources configured by different cyclic shifts (CSs) (frequency domain codes) and orthogonal cover codes (OCs or OCCs) (time domain spreading codes) of a computer-generated constant amplitude zero auto correlation (CG-CAZAC) sequence. An OC includes a Walsh/DFT orthogonal code, for example. If the number of CSs is 6 and the number of OCs is 3, a total of 18 UEs can be multiplexed in the same physical resource block (PRB) on a single antenna basis. Orthogonal sequences w_0, w_1, w_2, w_3 may be applied in the arbitrary time domain (after FFT modulation) or in the arbitrary frequency domain (prior to FFT modulation).

An ACK/NACK resource composed of CS, OC and PRB may be given to a UE through radio resource control (RRC) for SR and persistent scheduling. The ACK/NACK resource may be implicitly provided to the UE by the lowest CCE index of a PUCCH corresponding to a PDSCH for dynamic ACK/NACK and non-persistent scheduling.

FIG. 15 illustrates PUCCH formats 2/2a/2b in case of normal CP and FIG. 16 illustrates PUCCH formats 2/2a/2b in case of extended CP. Referring to FIGS. 15 and 16, one subframe includes 10 QPSK data symbols in addition to RS symbols in case of normal CP. Each of the QPSK symbols is spread in the frequency domain by CS and then mapped to the corresponding SC-FDMA symbol. SC-FDMA symbol level CS hopping may be applied to randomize inter-cell interference. An RS may be multiplexed by CDM using CSs. For example, if the number of available CSs is 12 or 6, 12 or 6 UEs can be multiplexed in the same PRB. That is, a plurality of UEs can be multiplexed by CS+OC+PRB and CS+PRB in PUCCH formats 1/1a/1b and 2/2a/2b respectively.

Orthogonal sequences with length-4 and length-3 for PUCCH formats 1/1a/1b are shown in Table 7 and Table 8.

TABLE 7

Length-4 orthogonal sequences for PUCCH formats 1/1a/1b		
Sequence index $n_{oc}(n_s)$	Orthogonal sequences $[w(0) \dots w(N_{SF}^{PUCCH} - 1)]$	
0	[+1 +1 +1 +1]	
1	[+1 -1 +1 -1]	
2	[+1 -1 -1 +1]	

13

TABLE 8

Length-3 orthogonal sequences for PUCCH formats 1/1a/1b	
Sequence index $n_{oc}(n_s)$	Orthogonal sequences [w(0) . . . w(N _{SF} ^{PUCCH} - 1)]
0	[1 1 1]
1	[1 e ^{j2π/3} e ^{j4π/3}]
2	[1 e ^{j4π/3} e ^{j2π/3}]

Orthogonal sequences for RS in PUCCH formats 1/1a/1b are shown in Table 9.

TABLE 9

1a and 1b		
Sequence index $n_{oc}(n_s)$	Normal cyclic prefix	Extended cyclic prefix
0	[1 1 1]	[1 1]
1	[1 e ^{j2π/3} e ^{j4π/3}]	[1 -1]
2	[1 e ^{j4π/3} e ^{j2π/3}]	N/A

14

A representative index n_r includes n_{cs} , n_{oc} and n_{rb} , where indexes indicating CS, OC and RB are n_{cs} , n_{oc} , and n_{rb} , respectively. Here, n_r satisfies $n_r = (n_{cs}, n_{oc}, n_{rb})$.

CQI, PMI, RI and a combination of CQI and ACK/NACK may be transmitted through PUCCH formats 2/2a/2b. In this case, Reed-Muller (RM) channel coding is applicable.

For example, channel coding for a UL CQI in an LTE system is described as follows. Bit stream $a_0, a_1, a_2, a_3, \dots, a_{A-1}$ is channel-coded using RM code (20,A). Table 10 shows a base sequence for code (20,A). Here, a_0 and a_{A-1} denote the most significant bit (MSB) and the least significant bit (LSB). In the case of extended CP, a maximum number of information bits is 11 in cases other than a case in which CQI and ACK/NACK are simultaneously transmitted. The UL CQI may be subjected to QPSK modulation after being coded into 20 bits using the RM code. The coded bits may be scrambled before being subjected to QPSK modulation.

TABLE 10

I	$M_{i,0}$	$M_{i,1}$	$M_{i,2}$	$M_{i,3}$	$M_{i,4}$	$M_{i,5}$	$M_{i,6}$	$M_{i,7}$	$M_{i,8}$	$M_{i,9}$	$M_{i,10}$	$M_{i,11}$	$M_{i,12}$
0	1	1	0	0	0	0	0	0	0	0	1	1	0
1	1	1	1	0	0	0	0	0	0	1	1	1	0
2	1	0	0	1	0	0	1	0	1	1	1	1	1
3	1	0	1	1	0	0	0	0	1	0	1	1	1
4	1	1	1	1	0	0	0	1	0	0	1	1	1
5	1	1	0	0	1	0	1	1	1	0	1	1	1
6	1	0	1	0	1	0	1	0	1	1	1	1	1
7	1	0	0	1	1	0	0	1	1	0	1	1	1
8	1	1	0	1	1	0	0	1	0	1	1	1	1
9	1	0	1	1	1	0	1	0	0	1	1	1	1
10	1	0	1	0	0	1	1	1	0	1	1	1	1
11	1	1	1	0	0	1	1	0	1	0	1	1	1
12	1	0	0	1	0	1	0	1	1	1	1	1	1
13	1	1	0	1	0	1	0	1	0	1	1	1	1
14	1	0	0	0	1	1	0	1	0	0	1	0	1
15	1	1	0	0	1	1	1	1	0	1	1	0	1
16	1	1	1	0	1	1	1	0	0	1	0	1	1
17	1	0	0	1	1	1	0	0	1	0	0	1	1
18	1	1	0	1	1	1	1	1	0	0	0	0	0
19	1	0	0	0	0	1	1	0	0	0	0	0	0

FIG. 17 illustrates ACK/NACK channelization for PUCCH formats 1a and 1b. FIG. 17 corresponds to a case of $\Delta_{shift}^{PUCCH}=2$.

FIG. 18 illustrates channelization for a hybrid structure of PUCCH formats 1/1a/1b and 2/2a/2b in the same PRB.

CS hopping and OC remapping may be applied as follows.

(1) Symbol-based cell-specific CS hopping for randomization of inter-cell interference

(2) Slot level CS/OC remapping

1) For inter-cell interference randomization

2) Slot-based access for mapping between ACK/NACK channels and resources (k)

Resource n_r for PUCCH formats 1/1a/1b includes the following combination.

(1) CS (corresponding to a DFT orthogonal code at a symbol level) n_{cs}

(2) OC (orthogonal code at a slot level) n_{oc}

(3) Frequency resource block (RB) n_{rb}

Channel-coded bits $b_0, b_1, b_2, b_3, \dots, b_{B-1}$ may be generated according to Equation 9.

$$b_i = \sum_{n=0}^{A-1} (a_n \cdot M_n) \bmod 2 \quad [\text{Equation 9}]$$

Here, $i=0, 1, 2, \dots, B-1$.

Table 11 shows an uplink control information (UCI) field for wideband (single antenna port, transmit diversity or open loop spatial multiplexing PDSCH) CQI feedback.

TABLE 11

Field	Band
Wideband CQI	4

15

Table 12 shows a UCI field for wideband CQI and PMI feedback. This field reports closed loop spatial multiplexing PDSCH transmission.

TABLE 12

Field	Band			
	2 antenna ports		4 antenna ports	
	Rank = 1	Rank = 2	Rank = 1	Rank > 1
Wideband CQI	4	4	4	4
Spatial differential CQI	0	3	0	3
PMI (Precoding Matrix Index)	2	1	4	4

Table 13 shows a UCI field for RI feedback for wideband report.

TABLE 13

Field	Bit widths		
	2 antenna ports	4 antenna ports	
		Maximum 2 layers	Maximum 4 layers
RI (Rank Indication)	1	1	2

FIG. 19 illustrates PRB allocation. As shown in FIG. 19, a PRB may be used for PUCCH transmission in slot n_s .

A multi-carrier system or a carrier aggregation system means a system using aggregation of a plurality of carriers having a bandwidth narrower than a target bandwidth for supporting wideband. When the plurality of carriers having a bandwidth narrower than the target bandwidth are aggregated, the bandwidth of the aggregated carriers may be limited to the bandwidths used in existing systems for backward compatibility with the existing systems. For example, an LTE system supports bandwidths of 1.4 MHz, 3 MHz, 5 MHz, 10 MHz, 15 MHz and 20 MHz and an LTE-A system evolved from the LTE system can support bandwidths wider than 20 MHz by using bandwidths supported by the LTE system. Alternatively, a new bandwidth may be defined to support carrier aggregation irrespective of the bandwidths used in existing systems. The term 'multi-carrier' can be used with carrier aggregation and bandwidth aggregation. Carrier aggregation collectively refers to both contiguous carrier aggregation and non-contiguous carrier aggregation.

FIG. 20 illustrates a concept of management of downlink component carriers in a BS and FIG. 21 illustrates a concept of management of uplink component carriers in a UE. For convenience of description, higher layers are simply referred to as a MAC layer in the following description.

FIG. 22 illustrates a concept of management of multiple carriers by one MAC layer in a BS and FIG. 23 illustrates a concept of management of multiple carriers by MAC layer in a UE.

Referring to FIGS. 22 and 23, one MAC layer manages and operates one or more frequency carriers for transmission and reception. In this case, resource management is flexible because frequency carriers managed by one MAC layer need not be contiguous. In FIGS. 22 and 23, one PHY layer corresponds to one component carrier. Here, one PHY layer does not necessarily mean an independent radio frequency

16

(RF) device. While one independent RF device means one PHY layer in general, one RF device is not limited thereto and may include multiple PHY layers.

FIG. 24 illustrates a concept of management of multiple carriers by multiple MAC layers in a BS and FIG. 25 illustrates a concept of management of multiple carriers by multiple MAC layers in a UE. FIG. 26 illustrates a concept of management of multiple carriers by multiple MAC layers in a BS and FIG. 27 illustrates a concept of management of multiple carriers by one or more MAC layers in a UE.

Distinguished from the structures shown in FIGS. 22 and 23, multiple carriers may be controlled by multiple MAC layers as shown in FIGS. 24 to 27.

Multiple MAC layers may control one-to-one multiple carriers as shown in FIGS. 24 and 25. Referring to FIGS. 26 and 27, MAC layers may control one-to-one some carriers and one MAC layer may control other carriers.

The above-described system includes one to N carriers which are contiguous or non-contiguous. This can be applied in both uplink and downlink. A TDD system is configured such that N carriers for downlink transmission and uplink transmission are operated and an FDD system is configured such that multiple carriers are respectively used for uplink and downlink. The FDD system may support asymmetrical carrier aggregation in which the numbers of aggregated carriers and/or carrier bandwidths are different between uplink and downlink.

When the number of aggregated component carriers in uplink equals that of downlink, it is possible to configure all component carriers such that they are compatible with the existing systems. However, the configurations of component carriers that are not considered to be compatible with the existing systems are not excluded from the present invention.

While the following description is made on the assumption that, when a PDCCH is transmitted using downlink component carrier #0, a PDSCH corresponding to the PDCCH is transmitted through downlink component carrier #0, it is apparent that the PDSCH can be transmitted through a different downlink component carrier using cross-carrier scheduling. The term 'component carrier' can be replaced with an equivalent term (e.g. cell).

FIG. 28 illustrates a scenario of transmitting UCI in a wireless communication system that supports carrier aggregation. This scenario is based on the assumption that UCI is ACK/NACK information. However, this is exemplary and UCI can include control information such as channel status information (e.g. CQI, PMI, RI, etc.) and scheduling request information (e.g. SR).

FIG. 28 illustrates asymmetrical carrier aggregation in which 5 DL CCs are linked to one UL CC. This asymmetrical carrier aggregation may be set from the viewpoint of UCI transmission. That is, DL CC-UL CC linkage for the UCI and DL CC-UL CC linkage for data may be different from each other. When it is assumed that one DL CC can transmit a maximum of two codewords, at least two UL ACK/NACK bits are needed. In this case, at least 10 ACK/NACK bits are necessary to transmit ACK/NACK information for data, received through 5 DL CCs, using one UL CC. If DTX status is also supported for each DL CC, at least 12 bits ($=5 \times 2 = 10 + 2 = 12$ bits) are needed for ACK/NACK transmission. The conventional PUCCH formats 1a/1b can transmit ACK/NACK information having a maximum of 2 bits, and thus it cannot transmit ACK/NACK information having an increased number of bits. While it has been described that carrier aggregation increases the quantity of UCI, an increase in the number of antennas, presence of a backhaul

subframe in a TDD system and a relay system, etc. may cause an increase in the quantity of UCI. Similarly to ACK/NACK information, when control information related to a plurality of DL CCs is transmitted through one UL CC, the quantity of the control information increases. For example, when CQI/PMI/RI related to a plurality of DL CCs is transmitted through, a UCI payload may increase. A DL CC and a UL CC may also be respectively called a DL cell and a UL cell and an anchor DL CC and an anchor UL CC may be respectively called a DL primary cell (PCell) and a UL PCell.

The DL primary CC may be defined as a DL CC linked with the UL primary CC. Here, linkage includes both implicit linkage and explicit linkage. In LTE, one DL CC and one UL CC are uniquely paired. For example, a DL CC linked with the UL primary CC according to LTE pairing can be called the DL primary CC. This can be regarded as implicit linkage. Explicit linkage means that a network configures a linkage in advance and it may be signaled through RRC. In explicit linkage, a DL CC paired with the UL primary CC may be called the DL primary CC. Here, the UL primary (anchor) CC may be a UL CC that carries a PUCCH. Otherwise, the UL primary CC may be a UL CC that carries UCI over a PUCCH or a PUSCH. The DL primary CC can be configured through higher layer signaling. The DL primary CC may be a DL CC through which a UE performs initial access. DL CCs other than the DL primary CC can be called DL secondary CCs. Similarly, UL CCs other than the UL primary CC can be called UL secondary CCs.

DL-UL pairing may correspond to FDD only. DL-UL pairing may not be additionally defined for TDD because TDD uses the same frequency. DL-UL linkage may be determined from UL linkage through UL EARFCN information of SIB2. For example, DL-UL linkage can be obtained through SIB2 decoding in the event of initial access and acquired through RRC signaling in other cases. Accordingly, only SIB2 linkage is present and other DL-UL pairing may not be explicitly defined. For example, in a 5DL:1UL structure shown in FIG. 28, DL CC#0 and UL CC#0 is in a SIB2 linkage relationship and other DL CCs may be in the SIB2 linkage relationship with other UL CCs that are not set to the corresponding UE.

Although embodiments of the present invention are herein focused on asymmetric carrier aggregation, it is merely for illustrative purpose and the present invention can be applied to various carrier aggregation scenarios including symmetric carrier aggregation.

A scheme for efficiently transmitting an increased quantity of UCI will now be described. Specifically, a new PUCCH format/signal processing procedure/resource allocation method for transmitting an increased quantity of UCI are proposed. In the following description, the PUCCH format proposed by the present invention is referred to as a new PUCCH format, LTE-A PUCCH format, or PUCCH format 3 in view of the fact that up to PUCCH format 2 has been defined in LTE. The technical spirit of the PUCCH format proposed by the present invention can be easily applied to an arbitrary physical channel (e.g. PUSCH) capable of transmitting UCI using the same or similar scheme. For example, an embodiment of the present invention can be applied to a periodic PUSCH structure that periodically transmits control information or an aperiodic PUSCH structure that aperiodically transmits control information.

In the following description, the UCI/RS symbol structure of the existing PUCCH format 1 (normal CP) of LTE is used

as a subframe/slot level UCI/RS symbol structure applied to PUCCH format 3 according to an embodiment of the present invention. However, the subframe/slot level UCI/RS symbol structure is exemplary and the present invention is not limited to a specific UCI/RS symbol structure. In the PUCCH format 3 according to the present invention, the number of UCI/RS symbols, positions of the UCI/RS symbols, etc. may be freely changed according to system designs. For example, the PUCCH format 3 according to the present invention can be defined using the RS symbol structures of the existing PUCCH format 2/2a/2b of LTE.

The PUCCH format 3 according to embodiments of the present invention can be used to transmit arbitrary types/sizes of UCI. For example, the PUCCH format 3 can transmit information such as ACK/NACK, CQI, PMI, RS, SR, etc. or a combination thereof. This information may have a payload of an arbitrary size. Description of the following embodiments and drawings are focused on a case in which the PUCCH format 3 according to the present invention transmits ACK/NACK information.

Example 1

FIGS. 29a to 29f illustrate PUCCH format structures and signal processing procedures for the same according to an embodiment of the present invention.

FIG. 29a illustrates a case in which the PUCCH format according to the present invention is applied to PUCCH format 1 (normal CP). Referring to FIG. 29a, a channel coding block channel-codes information bits a_0, a_1, \dots, a_{M-1} (e.g. multiple ACK/NACK bits) to generate encoded bits (coded bits or coding bits) (or a codeword) b_0, b_1, \dots, b_{N-1} . Here, M denotes an information bit size and N denotes an encoded bit size. The information bits include multiple ACK/NACK bits for a plurality of data (or PDSCH) received through a plurality of DL CCs, for example. The information bits a_0, a_1, \dots, a_{M-1} are joint-coded regardless of the type/number/size of UCI that forms the information bits. For example, when the information bits include multiple ACK/NACK bits for a plurality of DL CCs, channel coding is performed for all information bits instead of each DL CC and each ACK/NACK bit to generate a single codeword. Channel coding is not limited thereto and includes simplex repetition, simplex coding, RM coding, punctured RM coding, Tail-biting convolutional coding (TBCC), low-density parity-check (LDPC) or turbo-coding. The encoded bits can be rate-matched in consideration of a modulation order and resource quantity, which is not shown in the figure. The rate matching function may be included in the channel coding block or may be executed through a separate functional block.

A modulator modulates the encoded bits b_0, b_1, \dots, b_{N-1} to generate modulation symbols c_0, c_1, \dots, c_{L-1} where L denotes the size of the modulation symbols. A modulation method is performed by modifying the size and phase of a transmission signal. For example, the modulation method includes n -PSK (Phase Shift Keying) and n -QAM (Quadrature Amplitude Modulation) (n being an integer of 2 or greater). Specifically, the modulation method may include BPSK (Binary PSK), QPSK (Quadrature PSK), 8-PSK, QAM, 16-QAM, 64-QAM, etc.

A divider divides the modulation symbols c_0, c_1, \dots, c_{L-1} into slots. The order/pattern/scheme of dividing the modulation symbols into slots are not particularly limited. For example, the divider can sequentially divide the modulation symbols into the slots (localized scheme). In this case, modulation symbols $c_0, c_1, \dots, c_{L/2-1}$ can be divided

into slot 0 and modulation symbols $c_{L/2}$, $c_{L/2+1}$, . . . , c_{L-1} can be divided into slot 1, as shown in FIG. 29a. Furthermore, the modulation symbols may be interleaved (or permuted) when divided into the slots. For example, even-numbered modulation symbols can be divided into slot 0 and odd-numbered modulation symbols can be divided into slot 1. The order of the modulation operation and division operation may be changed.

A DFT precoder performs DFT precoding (e.g. 12-point DFT) for the modulation symbols divided into each slot in order to generate a single carrier waveform. Referring to FIG. 29a, the modulation symbols c_0 , c_1 , . . . , $c_{L/2-1}$ divided into slot 0 can be DFT-precoded into DFT symbols d_0 , d_1 , . . . , $d_{L/2-1}$ and the modulation symbols $c_{L/2}$, $c_{L/2+1}$, . . . , c_{L-1} divided into slot 1 can be DFT-precoded into DFT symbols $d_{L/2}$, $d_{L/2+1}$, . . . , d_{L-1} . DFT precoding can be replaced by other corresponding linear operations (e.g. Walsh precoding).

A spreading block spreads the DFT precoded signal at an SC-FDMA symbol level (time domain). Time domain spreading at an SC-FDMA symbol level is performed using a spreading code (sequence). The spreading code includes a quasi-orthogonal code and an orthogonal code. The quasi-orthogonal code includes a pseudo noise (PN) code. However, the quasi-orthogonal code is not limited thereto. The orthogonal code includes a Walsh code and a DFT code. However, the orthogonal code is not limited thereto. In the following description, the orthogonal code is used as the spreading code for ease of description. However, the orthogonal code is exemplary and can be replaced by the quasi-orthogonal code. The maximum value of spreading code size (or spreading factor SF) is limited by the number of SC-FDMA symbols used for control information transmission. For example, when 4 SC-FDMA symbols are used for control information transmission in one slot, a (quasi) orthogonal code w_0 , w_1 , w_2 , w_3 having a length of 4 can be used for each slot. The SF means a spreading degree of control information and may be related to a UE multiplexing order or an antenna multiplexing order. The SF can be changed to 1, 2, 3, 4, . . . according to system requirements, and pre-defined between a BS and a UE or signaled to the UE through DCI or RRC signaling. For example, when one of SC-FDMA symbols for control information is punctured in order to transmit an SRS, a spreading code with a reduced SF (e.g. SF=3 instead of SF=4) can be applied to control information of the corresponding slot.

The signal generated through the above-mentioned procedure is mapped to subcarriers in a PRB and then subjected to IFFT to be transformed into a time domain signal. A cyclic prefix is added to the time domain signal to generate SC-FDMA symbols which are then transmitted through an RF unit.

The above-mentioned procedure will now be described in more detail on the assumption that ACK/NACK bits for 5 DL CCs are transmitted. When each DL CC can transmit 2 PDSCHs, ACK/NACK bits for the DL CC may be 12 bits if a DTX status is included. A coding block size (after rate matching) may be 48 bits on the assumption that QPSK and SF=4 time spreading are used. Encoded bits are modulated into 24 QPSK symbols and 12 QPSK symbols are divided into each slot. In each slot, 12 QPSK symbols are converted to 12 DFT symbols through 12-point DFT. In each slot, 12 DFT symbols are spread and mapped to 4 SC-FDMA symbols using a spreading code with SF=4 in the time domain. Since 12 bits are transmitted through [2 bits×12

subcarriers×8 SC-FDMA symbols], the coding rate is 0.0625 (=12/192). In the case of SF=4, a maximum of 4 UEs can be multiplexed per PRB.

The signal mapped to the PRB in the procedure shown in FIG. 29a may be obtained through various equivalent signal processing procedures. Signal processing procedures equivalent to the signal processing procedure of FIG. 29a will now be described with reference to FIGS. 29b to 29g.

FIG. 29b shows a case in which the order of operations of the DFT precoder and the spreading block of FIG. 29a is changed. The function of the spreading block corresponds to operation of multiplying a DFT symbol sequence output from the DFT precoder by a specific constant at the SC-FDMA symbol level, and thus the same signal value is mapped to SC-FDMA symbols even though the order of operations of the DFT precoder and the spreading block is changed. Accordingly, the signal processing procedure for the PUCCH format 3 can be performed in the order of channel coding, modulation, division, spreading and DFT precoding. In this case, the division and spreading may be performed by one functional block. For example, modulation symbols can be alternately divided into slots and, simultaneously, spread at the SC-FDMA symbol level. Alternatively, the modulation symbols can be copied such that they correspond to the size of a spreading code when divided into the slots, and the copied modulation symbols can be multiplied one-to-one by respective elements of the spreading code. Accordingly, a modulation symbol sequence generated for each slot is spread to a plurality of SC-FDMA symbols. Then, a complex symbol sequence corresponding to the SC-FDMA symbols is DFT-precoded for each SC-FDMA symbol.

FIG. 29c shows a case in which the order of operations of the modulator and the divider of FIG. 29a is changed. In this case, in the signal processing procedure for PUCCH format 3, joint channel coding and division are performed at the subframe level, and modulation, DFT precoding and spreading are sequentially performed at the slot level.

FIG. 29d shows a case in which the order of operations of the DFT precoder and the spreading block of FIG. 29c is changed. As described above, since the function of the spreading block corresponds to operation of multiplying a DFT symbol sequence output from the DFT precoder by a specific constant at the SC-FDMA symbol level, the same signal value is mapped to SC-FDMA symbols even though the order of operations of the DFT precoder and the spreading block is changed. Accordingly, in the signal processing procedure for PUCCH format 3, joint channel coding and division are performed at the subframe level, and modulation is carried out at the slot level. The modulation symbol sequence generated for each slot is spread to a plurality of SC-FDMA symbols and DFT-precoded for each SC-FDMA symbol. In this case, the modulation and spreading operations can be performed by one functional block. For example, the generated modulation symbols can be directly spread at the SC-FDMA symbol level during modulation of the encoded bits. Alternatively, during modulation of the encoded bits, the generated modulation symbols can be copied such that they correspond to the size of the spreading code and multiplied one-to-one by respective elements of the spreading code.

FIG. 29e shows a case in which PUCCH format 3 according to the present embodiment is applied to PUCCH format 2 (normal CP) and FIG. 29f shows a case in which PUCCH format 3 according to the present embodiment is applied to PUCCH format 2 (extended CP). While a basic signal processing procedure is the same as the procedures

described with reference to FIGS. 29a to 29d, the numbers/positions of UCI SC-FDMA symbols and RS SC-FDMA symbols are different from those of FIG. 29a since PUCCH format 2 of LTE is reused.

Table 14 shows RS SC-FDMA symbol position in the PUCCH format 3. It is assumed that the number of SC-FDMA symbols in a slot is 7 (indexes: 0 to 6) in case of normal CP and 6 (indexes: 0 to 5) in case of extended CP.

TABLE 14

PUCCH format 3	RS SC-FDMA symbol position		Note
	Normal CP	Extended CP	
	2, 3, 4	2, 3	Reuse PUCCH format 1
	1, 5	3	Reuse PUCCH format 2

Tables 15 and 16 show exemplary spreading codes according to SF value. Table 15 shows DFT codes with SF=5 and SF=3 and Table 16 shows Walsh codes with SF=4 and SF=2. A DFT code is an orthogonal code represented by $\bar{w}_m = [w_0 \ w_1 \ \dots \ w_{k-1}]$, where $w_k = \exp(j2\pi km/SF)$ where k denotes a DFT code size or SF value and m is 0, 1, . . . , SF-1. Tables 15 and 16 show a case in which m is used as an index for orthogonal codes.

TABLE 15

Index m	Orthogonal code $\bar{w}_m = [w_0 \ w_1 \ \dots \ w_{k-1}]$	
	SF = 5	SF = 3
0	[1 1 1 1 1]	[1 1 1]
1	$[1 \ e^{j2\pi/5} \ e^{j4\pi/5} \ e^{j6\pi/5} \ e^{j8\pi/5}]$	$[1 \ e^{j2\pi/3} \ e^{j4\pi/3}]$
2	$[1 \ e^{j4\pi/5} \ e^{j8\pi/5} \ e^{j2\pi/5} \ e^{j6\pi/5}]$	$[1 \ e^{j4\pi/3} \ e^{j2\pi/3}]$
3	$[1 \ e^{j6\pi/5} \ e^{j2\pi/5} \ e^{j8\pi/5} \ e^{j4\pi/5}]$	
4	$[1 \ e^{j8\pi/5} \ e^{j6\pi/5} \ e^{j4\pi/5} \ e^{j2\pi/5}]$	

TABLE 16

Index m	Orthogonal code	
	SF = 4	SF = 2
0	[+1 +1 +1 +1]	[+1 +1]
1	[+1 -1 +1 -1]	[+1 -1]
2	[+1 +1 -1 -1]	
3	[+1 -1 -1 +1]	

Code index m may be designated in advance or signaled from the BS. For example, the code index m can be implicitly linked with a CCE index (e.g. the lowest CCE index) constituting a PDCCH. The code index m may be explicitly designated through a PDCCH or RRC signaling. Furthermore, the code index m may be derived from a value designated through the PDCCH or RRC signaling. The code index m may be independently given for each subframe, each slot, and multiple SC-FDMA symbols. Preferably, the code index m can be changed for each subframe, each slot and multiple SC-FDMA symbols. That is, the code index m can be hopped at a predetermined interval.

Cell-specific scrambling using a scrambling code (e.g. a PN code such as a Gold code) corresponding to a physical cell ID (PCI) or UE-specific scrambling using a scrambling code corresponding to a UE ID (e.g. RNTI) can be additionally applied for inter-cell interference randomization,

which is not shown in the figure. Scrambling may be performed for the entire information, performed in SC-FDMA symbols, carried out between SC-FDMA symbols, or carried out for both the entire information and SC-FDMA symbols. Scrambling the entire information can be achieved by performing scrambling on the information bits, encoded bits and modulation symbols prior to division. Intra-SC-FDMA symbol scrambling may be implemented by performing scrambling on the modulation symbols or DFT symbols after division. Inter-SC-FDMA symbol scrambling may be achieved by carrying out scrambling on the SC-FDMA symbols in the time domain after spreading.

UE multiplexing can be achieved by applying CDM before being subjected to the DFT precoder. For example, the signal before being subjected to the DFT precoder is a time domain signal, and thus CDM can be implemented through circular shift (or cyclic shift) or Walsh (or DFT) spreading. CDM can be performed at the information bit level, encoded bit level and modulation symbol level. Specifically, a case of multiplexing 2 UEs to one SC-FDMA symbol using a Walsh code with SF=2 is exemplified. When QPSK is performed on 12 encoded bits, a complex signal of $a_0 \ a_1 \ a_2 \ a_3 \ a_4 \ a_5$ is generated. An example of spreading control information of each UE using Walsh code [+1 +1] [+1 -1] is as follows.

UE#0: [+1 +1] is applied. $a_0 \ a_1 \ a_2 \ a_3 \ a_4 \ a_5 \ a_0 \ a_1 \ a_2 \ a_3 \ a_4 \ a_5$ are transmitted.

UE#1: [+1 -1] is applied. $a_0 \ a_1 \ a_2 \ a_3 \ a_4 \ a_5 \ -a_0 \ -a_1 \ -a_2 \ -a_3 \ -a_4 \ -a_5$ are transmitted.

In this case, interleaving may be additionally performed. The interleaving may be applied before or after spreading. An example of applying both the spreading and interleaving is as follows.

UE#0: [+1 +1] is applied. $a_0 \ a_0 \ a_1 \ a_1 \ a_2 \ a_2 \ a_3 \ a_3 \ a_4 \ a_4 \ a_5 \ a_5$ are transmitted.

UE#1: [+1 -1] is applied. $a_0, -a_0, a_1, -a_1, a_2, -a_2, a_3, -a_3, a_4, -a_4, a_5, -a_5$ are transmitted.

A signal generated from spreading and/or interleaving in a stage prior to the DFT precoder is subjected to DFT precoding (and additionally subjected to time spreading at the SC-FDMA symbol level as necessary) and mapped to sub-carriers of the corresponding SC-FDMA symbols.

FIG. 30 illustrates another exemplary PUCCH format according to the present embodiment of the invention. While the PUCCH format shown in FIG. 30 has the same basic structure as that of the PUCCH format shown in FIG. 29, the PUCCH format of FIG. 30 is different from the PUCCH format of FIG. 29 in that the same encoded bits are repeated on a slot-by-slot basis. Accordingly, a signal processing block shown in FIG. 30 does not include a divider.

A description will be given of methods of allocating a PUCCH resource to a UE on the assumption that multiple ACK/NACK bits are transmitted for data received through a plurality of DL CCs. For convenience of description, the PUCCH resource includes a resource for control information transmission and/or a resource for RS transmission and it is assumed that a (quasi) orthogonal resource for control information transmission is referred to as resource A and a (quasi) orthogonal resource for RS transmission is referred to as resource B. Resource A includes at least one of a PRB index and a spreading code (e.g. Walsh code) index. One representative logical index may be given for resource A and the PRB index and spreading code index may be derived from the representative logical index. Resource B includes at least one of a PRB index, a circular shift index and an orthogonal cover index. One representative logical index may be given for resource B, and the PRB index, circular

shift index and orthogonal cover index may be inferred from the representative logical index. The logical indexes of resource A and resource B may be linked with each other. Furthermore, indexes of resources constituting resource A and resource B may be linked with each other. Alternatively, a separate (representative) PUCCH resource index may be defined and linked with resource A and/or resource B. That is, resource A and/or resource B may be inferred from the separate PUCCH resource index.

A first resource allocation method signals both resource A and resource B. For example, both resource A and resource B can be signaled through physical control channel (e.g. PUCCH) or RRC signaling. In this case, the resource A index for control information transmission and the resource B index for RS transmission may be respectively signaled or only one thereof may be signaled. For example, if RS format and indexing conform to LTE, only resource B index for RS transmission can be signaled. Because it is preferable to transmit control information in the same PRB as that of the RS, the PRB index for the control information may be derived from the resource B index for the RS, and the control information may be transmitted through a PRB corresponding to the PRB index. The orthogonal code index used for the control information may be derived from the orthogonal cover index or circular shift index used for the RS. Alternatively, it is possible to signal an additional PUCCH resource index and infer resource A and/or resource B from the additional PUCCH resource index. That is, when the additional PUCCH resource index is given, the PRB and/or the orthogonal cover index for the control information and the PRB, orthogonal cover index and/or circular shift index for the RS can be inferred from the additional PUCCH resource index.

To reduce signaling overhead and efficiently use resources, a plurality of candidate PUCCH resources (indexes) can be signaled to a UE or a UE group through higher layer signaling (e.g. RRC signaling) and a specific PUCCH resource (index) can be indicated through a physical control channel (e.g. PDCCH). As described above, a PUCCH resource (index) can be given as [resource A index and resource B index], [resource A index or resource B index] or [separate PUCCH resource index]. Specifically, the PUCCH resource index can be signaled through a PDCCH of a DL secondary CC. When carrier aggregation is applied, transmit power control (TPC) of a DL secondary CC need not be used because a PUCCH is transmitted through the UL primary CC only. Accordingly, the PUCCH resource (index) can be signaled through a TPC field of a PDCCH transmitted through a DL secondary CC.

A second resource allocation method reuses the implicit method of LTE in case of dynamic ACK/NACK resource allocation. For example, a resource index that corresponds to the lowest CCE index of a PDCCH corresponding to a DL grant of a specific DL CC (e.g. primary DL CC) and conforms to LTE rule ($n_r = n_{cce} + N_{PUCCH}^{(1)}$) can be inferred. Here, n_r denotes the resource A (and/or resource B) index, n_{cce} denotes the lowest CCE index constituting the PDCCH, and $N_{PUCCH}^{(1)}$ denotes a value configured by a higher layer. For example, the RS can use a resource corresponding to the inferred resource index. In the case of control information, the PRB index can be derived from the inferred resource index and ACK/NACK information for a plurality of DL CCs can be transmitted using a corresponding resource (e.g. spreading code) in the PRB corresponding to the PRB index. When the resource index corresponding to the RS is inferred from the resource index corresponding to the control information, the circular shift index used for the

RS cannot be derived from the resource index corresponding to the control information because the resource corresponding to the circular shift index from among RS resources (e.g. a combination of the circular shift, orthogonal cover and PRB index) is not used for the control information.

A scheme of transmitting a PUCCH using a multi-antenna transmission method will now be described. While 2Tx transmit diversity scheme is described in the following embodiment, the embodiment can be equally/similarly applied to an n-Tx transmit diversity scheme. It is assumed that a (quasi) orthogonal resource for control information transmission is referred to as resource A and a (quasi) orthogonal resource for RS transmission is referred to as resource B. Logical indexes of resource A and resource B may be linked with each other. For example, if the logical index of resource B is given, the logical index of resource A can be automatically provided. The logical indexes of resource A and resource B may be configured through different physical configuration methods. The following two cases are present.

1) Control information can be transmitted through the same PRB at all antennas (ports).

A. The control information can be transmitted through two different resources A (e.g. Walsh or DFT codes with different indexes) selected for each antenna (port).

B. An RS can be transmitted through two different resources B (e.g. a combination of a circular shift and a DFT cover) selected for each antenna (port).

2) The control information can be transmitted through different PRBs for antennas. For example, the control information can be transmitted through PRB#4 at antenna (port) 0 and transmitted through PRB#6 at antenna (port) 1.

A. Resources for the control information transmitted through different antennas (ports) are not particularly limited (i.e. the resources can be equal to and different from each other).

B. Resources for RSs transmitted through different antennas (ports) are not particularly limited (i.e. the resources can be equal to and different from each other).

In a multi-antenna transmit (e.g. 2Tx transmit) mode, two resources A (e.g. orthogonal codes) for control information transmission and two resources B (e.g. a combination of a circular shift and a DFT cover) for RS transmission can be defined in advance or provided through physical control channel (e.g. PDCCH)/RRC signaling. In this case, signaling for the control information and RS can be individually performed. When resource information for one antenna (port) is signaled, resource information for the other antenna (port) can be inferred from the previously signaled resource information. For example, the spreading code index m for the control information can be designated in advance or signaled from the BS. Otherwise, the spreading code index m can be implicitly linked with a CCE index that configures a PDCCH. Or, the spreading code index m can be explicitly designated through PDCCH or RRC signaling. The spreading code index m can be linked with the orthogonal code index or circular shift index for the RS. The spreading code index m can be changed on a subframe, slot or multi-SC-FDMA symbol basis. That is, the spreading code index m can be hopped in the unit of a specific interval (e.g. slot).

Example 2

FIGS. 31 and 32 illustrate PUCCH format structures and signal processing procedures for the same according to another embodiment of the present invention. In the present embodiment, control information is FDM-mapped to the

frequency domain according to interleaving and local schemes. FDM mapping can be used for UE multiplexing or antenna (port) multiplexing. The present embodiment can be applied to CDM mapping using time/frequency domain cyclic shift.

Referring to FIG. 31, a channel coding block channel-codes information bits a_0, a_1, \dots, a_{M-1} (e.g. multiple ACK/NACK bits) to generate encoded bits (coded bits or coding bits) (or a codeword) b_0, b_1, \dots, b_{N-1} . Here, M denotes an information bit size and N denotes an encoded bit size. The information bits include multiple ACK/NACK bits, for example. The information bits a_0, a_1, \dots, a_{M-1} are joint-coded regardless of the type/number/size of UCI that forms the information bits. For example, when the information bits include multiple ACK/NACK bits for a plurality of DL CCs, channel coding is not performed per each DL CC or individual ACK/NACK bit but performed for all information bits, thereby generating a single codeword. Channel coding is not limited thereto and includes simple repetition, simplex coding, RM coding, punctured RM coding, Tail-biting convolutional coding (TBCC), low-density parity-check (LDPC) or turbo-coding. The encoded bits can be rate-matched in consideration of a modulation order and resource quantity, which is not shown in the figure. The rate matching function may be included in the channel coding block or may be executed through a separate functional block.

A modulator modulates the encoded bits b_0, b_1, \dots, b_{N-1} to generate modulation symbols c_0, c_1, \dots, c_{L-1} where L denotes the size of the modulation symbols. A modulation method is performed by modifying the size and phase of a transmission signal. For example, the modulation method includes n -PSK (Phase Shift Keying) and n -QAM (Quadrature Amplitude Modulation) (n being an integer of 2 or greater). Specifically, the modulation method may include BPSK (Binary PSK), QPSK (Quadrature PSK), 8-PSK, QAM, 16-QAM, 64-QAM, etc.

A divider divides the modulation symbols c_0, c_1, \dots, c_{L-1} into slots. The order/pattern/scheme of dividing the modulation symbols into slots are not particularly limited. For example, the divider can sequentially divide the modulation symbols into the slots (localized type). In this case, modulation symbols $c_0, c_1, \dots, c_{L/2-1}$ can be divided into slot 0 and modulation symbols $c_{L/2}, c_{L/2+1}, \dots, c_{L-1}$ can be divided into slot 1, as shown in FIG. 29a. Furthermore, the modulation symbols may be interleaved (or permuted) when divided into the slots. For example, even-numbered modulation symbols can be divided into slot 0 and odd-numbered modulation symbols can be divided into slot 1. The order of the modulation operation and division operation may be changed.

A DFT precoder performs DFT precoding (e.g. 6-point DFT) for the modulation symbols divided into each slot in order to generate a single carrier waveform. Referring to FIG. 29a, the modulation symbols $c_0, c_1, \dots, c_{L/2-1}$ divided into slot 0 can be DFT-precoded into DFT symbols $d_0, d_1, \dots, d_{L/2-1}$ and the modulation symbols $c_{L/2}, c_{L/2+1}, \dots, c_{L-1}$ divided into slot 1 can be DFT-precoded into DFT symbols $d_{L/2}, d_{L/2+1}, \dots, d_{L-1}$. DFT precoding can be replaced by another corresponding linear operation (e.g. Walsh precoding).

A spreading block spreads the DFT precoded signal at an SC-FDMA symbol level (time domain). Time domain spreading at an SC-FDMA symbol level is performed using a spreading code (sequence). The spreading code includes a quasi-orthogonal code and an orthogonal code. The orthogonal code includes a Walsh code and a DFT code. However,

the orthogonal code is not limited thereto. The maximum spreading code size (or spreading factor SF) is limited by the number of SC-FDMA symbols used for control information transmission. For example, when 4 SC-FDMA symbols are used for control information transmission in one slot, a (quasi) orthogonal code w_0, w_1, w_2, w_3 having a length of 4 can be used for each slot. The SF means a spreading degree of control information and may be related to a UE multiplexing order or an antenna multiplexing order. The SF can be changed to 1, 2, 3, 4, \dots according to system requirements, and pre-defined between a BS and a UE or signaled to the UE through DCI or RRC signaling. For example, when an SC-FDMA symbol for transmitting control information according to an SRS, a spreading code with SF=3 can be applied to control information of the corresponding slot. Examples of the spreading code may refer to Tables 15 and 16.

The signal generated through the above-mentioned procedure is mapped to subcarriers in a PRB. Distinguished from the first embodiment, the spread signal is non-contiguously mapped to the subcarriers in SC-FDMA symbols. FIG. 31 shows a case in which the spread signal is mapped in the SC-FDMA symbols in an interleaving manner and FIG. 32 shows a case in which the spread signal is mapped in the SC-FDMA symbols in a localized manner. The frequency domain signal mapped to the subcarriers is transformed to a time domain signal through IFFT. A CP is added to the time domain signal to generate SC-FDMA symbols which are then transmitted through an RF unit.

The above-mentioned procedure will now be described in more detail on the assumption that ACK/NACK bits for 5 DL CCs are transmitted. When each DL CC can transmit 2 PDSCHs, ACK/NACK bits for the DL CC may be 12 bits when a DTX status is included. A coding block size (after rate matching) may be 24 bits on the assumption that QPSK, SF=4 time spreading and non-contiguous mapping are used. Encoded bits are modulated into 12 QPSK symbols and 6 QPSK symbols are divided into each slot. In each slot, 6 QPSK symbols are converted to 6 DFT symbols through 6-point DFT. In each slot, 6 DFT symbols are spread and mapped to 4 SC-FDMA symbols using a spreading code with SF=4 in the time domain. Since 12 bits are transmitted through [2 bits \times 6 subcarriers \times 8 SC-FDMA symbols], the coding rate is 0.125(=12/96). In the case of SF=4, a maximum of 8 UEs can be multiplexed per PRB.

If a subcarrier spacing is changed from 2 blocks to blocks when the DFT symbols are mapped to the frequency domain, a maximum of 12 UEs can be multiplexed. When the subcarrier interval is configured to 4/6 blocks, a maximum of 16/24 UEs can be multiplexed. Here, the RS can employ the DFT code with SF=3 and circular shift used in LTE. In the case of a Walsh code with SF=4 in LTE, [1 1 -1 -1] is not used because the multiplexing order is limited by SF=3 of the RS. However, the present invention can define [1 1 -1 -1] such that it can be reused.

Cell-specific scrambling using a scrambling code (e.g. a PN code such as a Gold code) corresponding to a physical cell ID (PCI) or UE-specific scrambling using a scrambling code corresponding to a UE ID (e.g. RNTI) can be additionally applied for inter-cell interference randomization, which is not shown in the figure. Scrambling may be performed for the entire information, performed in SC-FDMA symbols, carried out between SC-FDMA symbols, or carried out for both the entire information and SC-FDMA symbols. Scrambling the entire information can be achieved by performing scrambling at the information bit level, encoded bit level or modulation symbol level prior to

division. Intra-SC-FDMA symbol scrambling may be implemented by performing scrambling on the modulation symbols or DFT symbols after division. Inter-SC-FDMA symbol scrambling may be achieved by carrying out scrambling on the SC-FDMA symbols in the time domain after spreading.

UE multiplexing can be achieved by applying CDM to a signal before being subjected to the DFT precoder. For example, the signal before being subjected to the DFT pre-coder is a time domain signal, and thus CDM can be implemented through circular shift (or cyclic shift) or Walsh (or DFT) spreading. CDM multiplexing can be performed for one at the information bit level, encoded bit level and modulation symbol level. Specifically, a case of multiplexing 2 UEs to one SC-FDMA symbol using a Walsh code with SF=2 is exemplified. When QPSK is performed on 6-bit encoded bits, a complex signal of a_0, a_1, a_2 is generated. Control information of each UE is spread using Walsh code [+1 +1] [+1 -1] as follows.

UE#0: [+1 +1] is applied. $a_0, a_1, a_2, a_0, a_1, a_2$ are transmitted.

UE#1: [+1 -1] is applied. $a_0, a_1, a_2, -a_0, -a_1, -a_2$ are transmitted.

In this case, interleaving may be additionally performed. The interleaving may be applied before or after spreading. Both the spreading and interleaving are applied as follows.

UE#0: [+1 +1] is applied. $a_0, a_0, a_1, a_1, a_2, a_2$ are transmitted.

UE#1: [+1 -1] is applied. $a_0, -a_0, a_1, -a_1, a_2, -a_2$ are transmitted.

FIGS. 33 and 34 illustrate another exemplary PUCCH format according to the present embodiment of the invention. While the PUCCH format shown in FIGS. 33 and 34 has the same basic structure as that of the PUCCH formats shown in FIGS. 31 and 32, the PUCCH format of FIGS. 33 and 34 is distinguished from the PUCCH format of FIGS. 31 and 32 in that the same encoded bits are repeated on a slot-by-slot basis. Accordingly, a signal processing block shown in FIGS. 33 and 34 does not include a divider.

A description will be given of methods of allocating a PUCCH resource to a UE on the assumption that multiple ACK/NACK bits are transmitted for data received through a plurality of DL CCs. For convenience of description, it is assumed that a (quasi) orthogonal resource for control information transmission is referred to as resource A and a (quasi) orthogonal resource for RS transmission is referred to as resource B. Resource A includes at least one of a PRB index, a spreading code (e.g. Walsh code) index and a subcarrier shift (or offset or index) according to frequency factor. One representative logical index may be given for resource A and the PRB index, spreading code index and a subcarrier shift (or offset or index) according to frequency factor may be derived from the representative logical index. Resource B includes at least one of a PRB index, a circular shift index and an orthogonal cover index. One representative logical index may be given for resource B, and the PRB index, circular shift index and orthogonal cover index may be inferred from the representative logical index. The logical indexes of resource A and resource B may be linked with each other. Furthermore, indexes of resources constituting resource A and resource B may be linked with each other.

A first resource allocation method signals both resource A and resource B. For example, both resource A and resource B can be signaled through physical control channel (e.g. PUCCH) or RRC signaling. In this case, the resource A index for control information transmission and the resource B index for RS transmission may be respectively signaled or only one thereof may be signaled. For example, if RS format

and indexing conform to LTE, only resource B index for RS transmission can be signaled. Because it is preferable to transmit control information in the same PRB as that of the RS, the PRB index for the control information may be derived from the resource B index for the RS and the control information may be transmitted through a PRB corresponding to the PRB index. The orthogonal code index used for the control information may be derived from the orthogonal cover index or circular shift index used for the RS. The subcarrier shift (or offset or index) according to frequency factor for resource A may be inferred from the circular shift index used for the RS. Alternatively, the subcarrier shift (or offset or index) according to frequency factor for resource A may be RRC signaled. Here, the frequency factor (or linear operation corresponding thereto, e.g. the reciprocal of the frequency factor) can be RRC signaled or implicitly determined on the basis of the number of DL CCs. That is, the frequency factor can be configured by the system or previously designated.

FDM mapping can also be applied to the RS. The RS can be directly generated in the frequency domain without a DFT precoder (i.e. the DFT precoder can be omitted) because a previously designated low-CM sequence is used whereas a low PAPR/CM signal is generated using DFT precoding in the case of control information. However, it may be technically preferable to apply CDM mapping using circular shift to the RS rather than FDM mapping for the following reason.

Design of sequences with various lengths is required when FDM mapping is used for the RS. That is, a new sequence with a length of 6 is needed when a frequency factor (FF) (or subcarrier interval) is 2 although a minimum sequence length for the RS is 12 in LTE.

When FDM mapping is used for the RS, channel estimation performance may be deteriorated in a high frequency selective channel because a channel of a specific frequency position is estimated and interpolation is performed on other positions. However, the channel estimation performance is not deteriorated because the RS covers all frequency regions in the case of CDM mapping.

A second resource allocation method reuses the implicit method of LTE in case of dynamic ACK/NACK resource allocation. For example, a resource index that corresponds to the lowest CCE index of a PDCCH corresponding to a DL grant of a specific DL CC (e.g. primary DL CC) and conforms to LTE rule ($n_r = n_{cce} + N_{PUCCH}^{(1)}$) can be inferred. Here, n_r denotes the resource A (and/or resource B) index, n_{cce} denotes the lowest CCE index constituting the PDCCH, and $N_{PUCCH}^{(1)}$ denotes a value configured by higher layers. For example, the RS can use a resource corresponding to the inferred resource index. In the case of control information, the PRB index can be derived from the inferred resource index and ACK/NACK information for a plurality of DL CCs can be transmitted using a corresponding resource (e.g. spreading code and/or subcarrier shift (or offset or index) according to frequency factor) in the PRB corresponding to the PRB index. When the resource index corresponding to the RS is inferred from the resource index corresponding to the control information, the circular shift index used for the RS cannot be derived from the resource index corresponding to the control information because the resource corresponding to the circular shift index from among RS resources (e.g. a combination of the circular shift, orthogonal cover and PRB index) is not used for the control information.

FIGS. 35 to 41 illustrate a method of defining a resource index according to an embodiment of the present invention. FIGS. 35 and 41 show a case in which a resource index (i.e. resource A index) for control information is defined as a combination of a subcarrier mapping pattern/position (e.g. subcarrier index of offset) and a spreading code (e.g. orthogonal code). When a PRB for RS transmission is confirmed, a PRB for control information transmission can be configured as the PRB for RS transmission. Otherwise, the PRB for control information transmission can be signaled through physical control channel (e.g. PDCCH)/RRC signaling. In the present embodiment, a subcarrier shift (or offset or index) according to frequency factor for the control information can be inferred from the circular shift index of the RS. Otherwise, the subcarrier shift (or offset or index) according to frequency factor can be RRC signaled. Here, the frequency factor can be RRC signaled or implicitly determined on the basis of the number of DL CCs. That is, the frequency factor can be configured by the system or previously designated. In this case, a representative index for indicating a combination (e.g. [PRB, spreading code] or [PRB, spreading code, frequency factor]) of detailed resources may not be separately defined in a channel resource for the control information.

Referring to FIGS. 35 to 41, numerals in boxes mean resource indexes (i.e. resource A indexes for control information transmission). In the present embodiment, resource indexes for the control information are linked with [orthogonal code indexes, subcarrier shifts (or offsets or indexes)]. Accordingly, the control information is spread at the SC-FDMA symbol level using an orthogonal code corresponding to resource indexes and mapped to subcarriers corresponding to the resource indexes. While the resource indexes are counted in ascending order of frequency resource (subcarrier index) in FIGS. 35 to 41, the resource indexes may be counted on the basis of the orthogonal code index axis. FIGS. 35b, 36b, 37b, 38b, 39b and 40b show that resource indexing for the control information is limited by an RS multiplexing order. For example, if the RS multiplexing order is 3 and a Walsh code with SF=4 is used for control information transmission, [+1 +1 -1 -1] (resource index 3) may not be used, as in LTE.

The resource indexes may be relative values (e.g. offset). For example, PUCCH format 2/2a/2b may be transmitted through the outermost portion of a band, 1 PRB in which PUCCH formats 1/1a/1b and 2/2a/2b coexist may be located inside the outermost portion of the band, and PUCCH format 1/1a/1b may be transmitted through a portion inside the portion where PUCCH formats 1/1a/1b and 2/2a/2b coexist in LTE. When a PRB for PUCCH format 1/1a/1b and a PRB for PUCCH format 2/2a/2b are present together (only one PRB is allowed in LTE), if the number of HARQ-ACK/NACK resources is M in the corresponding PRBs, n substantially represents M+n. In this case, each frequency resource (e.g., frequency factor) or orthogonal code index may be cell-specifically/UE-specifically hopped at the SC-FDMA symbol level/slot level.

FIG. 41 illustrates a case in which orthogonal resource indexes are staggered for each orthogonal code index or circularly shifted along the frequency axis. In this case, the resource indexes in FIG. 37a are staggered subcarrier by subcarrier for each orthogonal code index. Circular shifts or orthogonal code indexes can be cell-specifically/UE-specifically hopped at the SC-FDMA symbol level/slot level.

FIG. 42 illustrates a resource indexing method for an RS. Resource indexing for an RS may conform to the method defined in LTE.

Referring to FIG. 42, numerals in boxes denote resource indexes (i.e. indexes of resource B for RS transmission). In this example, the resource indexes for the RS are linked with [circular shift values, orthogonal code indexes]. Accordingly, an RS sequence is circular-shifted by a value corresponding to a resource index along the frequency axis and covered in the time domain with an orthogonal code corresponding to the resource index. In FIG. 42, Δ_{shift}^{PUCCH} denotes a circular shift interval and a used circular shift value may be $c \cdot \Delta_{shift}^{PUCCH}$ (c being a positive integer). A phase shift value according to a circular shift can be given as $\alpha(n_s, 1) = 2\pi \cdot n_{cs}(n_s, 1) / N_{sc}^{RB}$ where n_s is a slot index, 1 is an SC-FDMA symbol index, $n_{cs}(n_s, 1)$ is a circular shift value, and N_{sc}^{RB} denotes the number of subcarriers that form a resource block.

In this example, the resource indexes for the RS are counted first along the circular shift axis. However, the resource indexes may be counted first along the orthogonal code axis.

Δ_{shift}^{PUCCH} of the RS and the frequency factor of control information (or a corresponding linear operation, e.g. the reciprocal of the frequency factor) can be signaled through physical control channel (e.g. PDCCH) or RRC signaling.

Resource indexing for the control information may correspond to resource indexing for the RS. In this case, only one of the control information resource index and RS resource index may be signaled to a UE through physical control channel (e.g. PDCCH)/RRC signaling and the other may be inferred from the resource index signaled to the UE. For example, the frequency factor can be inferred from information (e.g. the circular shift spacing) about circular shift used in the RS. If conventional Δ_{shift}^{PUCCH} signaling is reused, both Δ_{shift}^{PUCCH} for the RS and the frequency factor (interval) for the control information can be designated through one-time Δ_{shift}^{PUCCH} signaling. Specifically, they are associated with resource indexing shown in FIG. 42 and resource indexing shown in FIGS. 35b, 36b, 37b, 38b, 39b and 40b, respectively.

Table 17 shows an example of mapping Δ_{shift}^{PUCCH} and the frequency factor.

TABLE 17

Δ_{shift}^{PUCCH}	Frequency Factor (FF)
1	1
2	2
3	3
4	4
6	6
12	12

Table 18 shows an example of mapping Δ_{shift}^{PUCCH} and the frequency factor in consideration of the number of available resources (i.e. multiplexing order). For example, when the multiplexing order according to circular shift is 6 in one SC-FDMA symbol, $\Delta_{shift}^{PUCCH}=2$ and FF=6 can be paired.

TABLE 18

Δ_{shift}^{PUCCH}	Frequency Factor (FF)	Multiplexing order due to circular shift only
1	12	12
2	6	6
3	4	4
4	3	3

TABLE 18-continued

Δ_{shift}^{PUCCH}	Frequency Factor (FF)	Multiplexing order due to circular shift only
6	2	2
12	1	1

Alternatively, the frequency factor can be RRC signaled or implicitly determined on the basis of the number of DL CCs. Specifically, the frequency factor can be implicitly determined on the basis of the number of configured DL CCs or on the basis of the number of activated DL CCs. For example, a frequency factor for 5 configured (activated) DL CCs can be configured to 2 in advance and used. Frequency factors for 4, 3, 2 and 1 configured (activated) DL CCs can be implicitly configured and used, respectively.

FIG. 43a illustrates a signal processing procedure to transmit control information through multiple antennas. Since the overall flow of the signal processing procedure shown in FIG. 43a is similar to those of embodiments 1 and 2, described with reference to FIGS. 29 to 34, the following description is focused on a transmit diversity (TxD) mapper, which is a main difference between the signal processing procedure of FIG. 43a and the signal processing procedures of FIGS. 29 to 34. The TxD mapper performs resource allocation/MIMO (Multiple Input Multiple Output) precoding/process for transmitting the control information through multiple antennas (ports).

A description will be given of a scheme of transmitting a PUCCH in a MIMO mode using the TxD mapper. While 2Tx transmit diversity scheme is described in the following embodiment, the embodiment can be equally/similarly applied to an n-Tx transmit diversity scheme. It is assumed that a (quasi) orthogonal resource for control information transmission is referred to as resource A and a (quasi) orthogonal resource for RS transmission is referred to as resource B. Logical indexes of resource A and resource B may be linked with each other. For example, if the logical index of resource B is given, the logical index of resource A can be automatically provided. The logical indexes of resource A and resource B may be configured through different physical configuration methods. The following two cases are present.

1) Control information can be transmitted through the same PRB at all antennas (ports).

A. The control information can be transmitted through two different resources A (e.g. a combination of an orthogonal code and a subcarrier shift (or offset or index) according to frequency factor). For example, the orthogonal code includes a Walsh code and a DFT code and the frequency factor can be given as N_{sc}/N_{freq} or the reciprocal thereof. Here, N_{sc} denotes the number of subcarriers in a PRB and N_{freq} denotes the number of subcarriers used for control information transmission.

B. An RS can be transmitted through two different resources B (e.g. a combination of a circular shift and a DFT cover) selected for each antenna (port).

2) The control information can be transmitted through different PRBs for antennas. For example, the control infor-

mation can be transmitted through PRB#4 at antenna (port) 0 and transmitted through PRB#6 at antenna (port) 1.

A. Resources for the control information transmitted through different antennas (ports) are not particularly limited (i.e. the resources can be equal to and different from each other).

B. Resources for RSs transmitted through different antennas (ports) are not particularly limited (i.e. the resources can be equal to and different from each other).

In a multi-antenna transmit (e.g. 2Tx transmit) mode, two resources A (e.g. a combination of an orthogonal code and subcarrier position (e.g. shift, offset or index) according to frequency factor) for control information transmission and two resources B (e.g. a combination of a circular shift and a DFT cover) for RS transmission can be defined in advance or provided through physical control channel (e.g. PDCCH)/RRC signaling. In this case, signaling for the control information and RS can be individually performed. When resource information for one antenna (port) is signaled, resource information for the other antenna (port) can be inferred from the previously signaled resource information. For example, code index m and/or the subcarrier position (e.g. shift, offset or index) according to frequency factor can be designated in advance or signaled from the BS. Otherwise, code index m and/or the subcarrier position (e.g. shift, offset or index) according to frequency factor can be implicitly linked with a CCE index that consists of a PDCCH. Or, code index m and/or the subcarrier position (e.g. shift, offset or index) according to frequency factor can be explicitly designated through PDCCH or RRC signaling. The code index m and/or the subcarrier position (e.g. shift, offset or index) according to frequency factor can be changed on a subframe, slot or multi-SC-FDMA symbol basis. That is, the code index m and/or the subcarrier position (e.g. shift, offset or index) according to frequency factor can be hopped in the unit of a specific time interval (e.g. slot).

If the multiplexing order for the RS is more than twice the multiplexing order for the control information, the following 2Tx transport diversity scheme can be applied. In this case, two from among resources CS+OC+PRB for the RS may be used for channel estimation of each transmit antenna and only one resource (subcarrier position+OC+PRB) may be used for the control information.

As another transport diversity scheme, the Alamouti scheme can be applied to an output value of the DFT precoder in the frequency domain. The Alamouti scheme can be represented by the following matrix.

$$\begin{pmatrix} s_1 & -s_2^* \\ s_2 & s_1^* \end{pmatrix} \quad \text{[Equation 10]}$$

Here, column 0 and column 1 respectively denote signal vectors transmitted through antenna (port) 0 and antenna (port) 1, row 0 and row 1 respectively denote complex signal vectors transmitted through first and second subcarriers, * represents complex conjugate operation. Any form linearly transformed from the matrix can be applied to the present invention.

When the Alamouti scheme is applied to the PUCCH format according to the embodiment of the present invention, the order of DFT symbols mapped to SC-FDMA symbols corresponding to antenna (port) 1 is changed for every two DFT symbols. For example, d_0, d_1, d_2, d_3 are mapped to the SC-FDMA symbols corresponding to antenna (port) 0 whereas $-d_1^*, d_0^*, -d_3^*, d_2^*$ are mapped to the SC-FDMA symbols corresponding to antenna (port) 1. This damages single carrier property of the signal mapped to antenna (port) 1, and thus CM increases at antenna (port) 1.

A multi-antenna coding scheme that does not cause CM increase even when the Alamouti scheme is applied will now be described with reference to FIGS. 43b and 43c. FIGS. 43b and 43c illustrate the spreading operation.

Referring to FIGS. 43b and 43c, when the control information is mapped to antenna (port) 0, the complex signal is mapped to subcarriers after being subjected to DFT precoding. When the control information is mapped to antenna (port) 1, (1) mapping to subcarriers in SC-FDMA symbols in reverse order, (2) complex conjugate operation and (3) alternative minus sign addition are performed. Operations (1), (2) and (3) are exemplary and the order of the operations can be changed. This scheme can be equally applied to the embodiments of the present invention. For example, referring to FIG. 29 or 30, a complex symbol sequence mapped to SC-FDMA symbols transmitted through a first antenna (port) and a second antenna (port) can be given as follows.

First antenna (port): a_k

Second antenna (port): $(-1)^{\text{mod}(k,2)} \cdot \text{conj}(a_{11-k})$ [Equation 11]

Here, a_k denotes the complex symbol sequence mapped to subcarriers of the SC-FDMA symbols, k denotes a complex symbol index (0 to 11), $\text{mod}(a, b)$ represents the remainder obtained when a is divided by b , and $\text{conj}(a)$ represents the complex conjugate value of a .

Equation 12 assumes a case in which the complex signal is mapped to all subcarriers in the SC-FDMA symbols. Equation 16 can be normalized to Equation 11 considering a case in which the frequency factor is used as shown in FIGS. 31 to 34.

First antenna (port): a_k

Second antenna (port): $(-1)^{\text{mod}(k,2)} \cdot \text{conj}(a_{n-k})$ or $(-1)^{\text{mod}(k+1,2)} \cdot \text{conj}(a_{n-k})$ [Equation 12]

Here, n represents (length of complex symbol sequence a_k mapped to the subcarriers of the SC-FDMA symbols)-1 (e.g. $0 \leq n \leq 11$).

The complex symbol sequence mapped to the SC-FDMA symbols transmitted through the first antenna (port) or the second antenna (port) can be circular-shifted (e.g. shifted by half the length of the complex symbol sequence) in the frequency domain. Tables 19 to 21 show cases in which the Alamouti scheme is applied according to the embodiment of the present invention.

TABLE 19

SC-FDMA	Subcarrier index											
symbol	0	1	2	3	4	5	6	7	8	9	10	11
Antenna (port) 0	a_0	a_1	a_2	a_3	a_4	a_5	a_6	a_7	a_8	a_9	a_{10}	a_{11}
Antenna (port) 1	$-a_{11}^*$	a_{10}^*	$-a_9^*$	a_8^*	$-a_7^*$	a_6^*	$-a_5^*$	a_4^*	$-a_3^*$	a_2^*	$-a_1^*$	a_0^*

TABLE 20

SC-FDMA	Subcarrier index											
symbol	0	1	2	3	4	5	6	7	8	9	10	11
Antenna (port) 0	a_0	a_1	a_2	a_3	a_4	a_5	a_6	a_7	a_8	a_9	a_{10}	a_{11}
Antenna (port) 1	$-a_5^*$	a_4^*	$-a_3^*$	a_2^*	$-a_1^*$	a_0^*	$-a_{11}^*$	a_{10}^*	$-a_9^*$	a_8^*	$-a_7^*$	a_6^*

TABLE 21

SC-FDMA	Subcarrier index											
symbol	0	1	2	3	4	5	6	7	8	9	10	11
Antenna (port) 0	a_0	a_1	a_2	a_3	a_4	a_5						
Antenna (port) 1	$-a_5^*$	a_4^*	$-a_3^*$	a_2^*	$-a_1^*$	a_0^*						

Example 3

FIG. 44 illustrates a PUCCH format structure and a signal processing procedure for the same according to a third embodiment of the present invention. Since the overall flow of the signal processing procedure is similar to those described with reference to FIGS. 29 to 43, the following description is focused on a CAZAC modulator that is a main difference between the signal processing procedure of FIG. 44 and the signal processing procedures of FIGS. 29 to 43.

Referring to FIG. 44, the CAZAC modulator modulates the modulation symbols $[c_0, c_1, \dots, c_{L/2-1}]$ and $[c_{L/2}, c_{L/2+1}, \dots, c_{L-1}]$ divided into corresponding slots into corresponding sequences to generate CAZAC modulation symbols $[d_0, d_1, \dots, d_{L/2-1}]$ and $[d_{L/2}, d_{L/2+1}, \dots, d_{L-1}]$. The CAZAC modulator includes a CAZAC sequence or a LTE computer generated (CG) sequence for 1RB. For example, if the LTE CG sequence is $r_0, \dots, r_{L/2-1}$, a CAZAC modulation symbol may be $d_n = c_n * r_n$ or $d_n = \text{conj}(c_n) * r_n$. While FIG. 44 illustrates slot-level joint coding, the present invention can be equally applied to separate coding for each slot, slot-level repetition, and a case in which a frequency factor is applied. In the present embodiment, cell-specific scrambling can be omitted because a CAZAC or CG sequence functioning as a base sequence is cell-specific. Otherwise, only UE-specific scrambling can be applied for greater randomization. A resource allocation method, relation with RS indexes, a signaling method, and transmit diversity can use the methods described in the above embodiments.

Example 4

A description will be given of a case in which dynamic ACK/NACK resource allocation is applied to the new PUCCH formats described in the first, second and third embodiments. The following description can be equally applied to other new PUCCH formats as well as the new PUCCH formats according to the present invention. For example, LTE PUCCH format 2 can be reused as a new PUCCH format for multi-ACK/NACK. In this case, resource indexing for ACK/NACK can employ the method used in LTE PUCCH format 2, that is, the method of indexing resources on the circular shift axis first, and then indexing PRBs. Use of LTE PUCCH format 2 as a new PUCCH format has the advantage of using an existing format. However, because only up to 13 bits can be supported and a coding rate is limited in PUCCH format 2, the PUCCH format 2 is inferior to the PUCCH formats described in the above embodiments in terms of flexibility and performance.

A region (or PRB) for a new PUCCH format can be defined as follows.

1. An additional PUCCH region (or PRB) for LTE-A can be defined in addition to the PUCCH region defined in LTE.

2. Part of the PUCCH region (or PRB) defined in LTE can be derived. That is, some resources of the PUCCH region can be used as resources for the new PUCCH format while the PUCCH region is defined according to LTE.

A description will be given of PUCCH format adaptation according to a carrier aggregation scenario. A PUCCH format used for PUCCH format adaptation is not limited. The PUCCH format adaptation described in the specification is divided into the following two types.

1. PUCCH format adaptation according to carrier aggregation configuration

2. Format adaptation on the basis of the number of PDCCHs and/or PDSCHs allocated to a UE

A. PUCCH format adaptation based only on the number of PDCCHs/PDSCHs

B. Format adaptation based on the number of DL CCs carrying PDCCHs or PDSCHs

The format adaptation scheme according to carrier aggregation configuration is described as a first PUCCH format adaptation scheme. When the number (N) of cell-specifically or UE-specifically aggregated DL CCs is less than a specific value (e.g. 2), a HARQ-ACK/NACK resource may correspond to the lowest CCE index as in LTE. Here, the aggregated DL CCs may be candidate DL CCs from which a PDCCH is detected for cross-carrier scheduling. Furthermore, the aggregated DL CCs may be some of DL CC sets configured for respective cells. Moreover, the aggregated DL CCs may be activated DL CCs. The PUCCH format used in this case may be the LTE PUCCH format 1/1a/1b.

Schemes that can be used when $N \geq 3$ include multi-sequence modulation (MSM) that performs simultaneous transmission using M ($M \leq N$) resources and HARQ-ACK/NACK multiplexing (or sequence selection) that selects some of resources and transmits the selected resources. The PUCCH format used in this case may be the LTE PUCCH format 1/1a/1b. When $N=1$, that is, when carrier aggregation is not performed (i.e. 1DL-1UL pairing), HARQ-ACK/NACK resources can use the LTE rule and PUCCH format 1/1a/1b.

When more than N DL CCs are cell-specifically or UE-specifically aggregated, HARQ-ACK/NACK can be transmitted through the new PUCCH formats described in the first, second and third embodiments. A PUCCH resource can be configured such that it corresponds to the lowest CCE index regardless of whether a region (or PRB) for a new PUCCH format is defined exclusively of LTE or defined compatibly with LTE. In this case, transmitted HARQ-ACK/NACK information may correspond to data transmitted through multiple DL CCs.

PUCCH format adaptation on the basis of the number of PDCCHs and/or PDSCHs assigned to a UE is described as a second PUCCH format adaptation scheme. While the number of DL CCs including PDSCHs equals the number of DL CCs including PDSCHs in general, they may become different from each other when cross-carrier scheduling is employed. Furthermore, if the number of PDSCHs or PDSCHs for each DL CC is limited to 1, the number of PDSCHs/PDSCHs may correspond to the number of DL CCs used for the PDSCHs. An implicit rule for HARQ-ACK/NACK resources may relate to the PDSCHs. Since the number of PDSCHs equals the number of PDSCHs, the following description is made on the basis of the number of PDSCHs. Furthermore, since PUCCH format adaptation based on the number of DL CCs carrying PDSCHs/PDSCHs can be achieved by extending the PUCCH format adaptation based on the number of PDSCHs, detailed description thereof is omitted.

When the number (N) of PDCCHs scheduled for one UE is less than a specific value, resources for HARQ-ACK/NACK transmission may correspond to the lowest CCE index according to the LTE rule. Here, a PUCCH format used in this case may be LTE PUCCH format 1/1a/1b. A scheme used when $N \geq 3$ may be MSM that performs simultaneous transmission using M ($M \leq N$) resources and HARQ-ACK/NACK multiplexing (or sequence selection) that selects some resources and transmits the selected resources. A PUCCH format used in this case may be LTE PUCCH format 1/1a/1b. When $N=1$, that is, when only one PDCCH

of one UE is scheduled, HARQ-ACK/NACK resources can use the LTE rule and PUCCH format 1/1a/1b.

HARQ-ACK/NACK can be transmitted through a newly defined PUCCH format when N or more PDCCHs are scheduled for one UE. A PUCCH resource can be configured such that it corresponds to the lowest CCE index regardless of whether regions (or PRB) for the new PUCCH format are defined exclusively or compatibly with regions for an LTE PUCCH format. In this case, multiple HARQ-ACK/NACK information may correspond to data transmitted through multiple DL CCs.

A description will be given of error handling. It is assumed that $N=2$ for convenience of description. If a scheduler transmits 2 PDCCHs (which may correspond to 2 PDSCHs transmitted through 2 DL CCs, in general) to one UE, the UE may mis-detect that one PDCCH has been scheduled. In this case, while the BS expects to receive HARQ-ACK/NACK information through the new PUCCH format for two or more PDCCHs, the UE transmits HARQ-ACK/NACK information through an LTE PUCCH format since the UE has detected one PDCCH. The BS recognizes that DTX is generated for the one PDCCH because the BS receives a PUCCH format different from the expected format.

Recognition of DTX status of the UE by the BS may affect performance in incremental redundancy (IR) based HARQ. When DTX is generated, for example, because the UE is not aware of the fact that a PDCCH has been transmitted, the UE cannot store a decoded soft bit result value of a PDSCH corresponding to the PDCCH in a soft buffer. Accordingly, it is necessary for the BS not to change a redundancy version (RV) or to transmit as many system bits as possible in the event of HARQ retransmission, upon generation of DTX. However, if the BS is not aware of the DTX status of the UE and performs retransmission with a different RV value, system throughput may be decreased because the RV is changed and system bits are lost during retransmission. For this reason, 3GPP signals the DTX status of the UE to the BS in standards from WCDMA.

A description will be given of a resource determination method for HARQ-ACK/NACK and a DTX handing method in a new PUCCH format. Here, it is assumed that the new PUCCH format can simultaneously transmit information including HARQ-ACK/NACK corresponding to multiple DL CCs and DTX statuses of DL CCs. For example, if 5 DL CCs are present and each DL CC transmits 2 code-words, the new PUCCH format can carry at least 12-bit information for supporting ACK/NACK and DTX for the 5 DL CCs.

While a case in which PUCCH resources for the new PUCCH format are exclusively reserved for each CC and a case in which at least some of a plurality of CCs are shared are described for facilitation of explanation, the present invention is not limited thereto. If 4 DL CCs are present and 10 PUCCH resources are reserved for each DL CC as an example of exclusive reservation of resources for PUCCH transmission for each CC, 40 ($=10*4$) PUCCH resources can be reserved, PUCCH resource indexes 0 to 9 can be used for DL CC#0, PUCCH resource indexes 10 to 19 can be used for DL CC#1, PUCCH resource indexes 20 to 29 can be used for DL CC#2, and PUCCH resource indexes 30 to 39 can be used for DL CC#3 (PUCCH resource stacking). If 4 DL CCs are present and 10 PUCCH resources are reserved for each DL CC as an example of sharing PUCCH resources by multiple CCs, PUCCH resource indexes 0 to 9 can be shared for all DL CCs.

As described above, a PUCCH region (or PRB) in which the new PUCCH format can be used can be defined as a new region (or a specific section of resources) for LTE-A or defined using some resources defined in LTE. Furthermore, "lowest CCE" concept can be used as in LTE or another implicit method can be applied.

An example of detailed resource allocation according to the present invention will now be described. It is assumed that 4 HARQ-ACK/NACK signals need to be transmitted for 4 PDSCHs transmitted through 4 DL CCs and the HARQ-ACK/NACK signals are transmitted through one UL CC (e.g. anchor UL carrier). Here, HARQ-ACK/NACK includes ACK, NACK, DTX and NACK/DTX. It is assumed that 10 PUCCH resources are reserved for each DL CC such that a total of 40 PUCCH resources are reserved. While the present embodiment is described for one UE (i.e., UE#0), it can be equally applied to multiple UEs. Furthermore, while the present embodiment describes sequential indexing of resources 0 to 39 in exclusive resource definition, it can also be applied to a case in which 4 PUCCH resource regions each having indexes 0 to 9 for each DL CCs are present.

FIG. 45 illustrates an example of transmitting multiple PDCCHs in association with a downlink assignment carrier index (DACI) at UE#0. In this case, statuses of all DL CCs for PDSCHs are transmitted according to the new PUCCH format, and thus it is difficult to apply CCE based implicit mapping of LTE. In the present embodiment, it is assumed that one PDCCH is transmitted to UE#0 for each CC, UE#0 successfully decodes all PDCCHs to generate no DTX, and CCE indexing in each DL CC starts from 0. Furthermore, CCE indexing can include CCE indexing of previous DL CCs. For example, CCE indexes for DL CC#1 may be 10 to 19.

A DACI is a counter for PDCCHs transmitted to a UE and is configured for each UE. When a plurality of PDCCHs is transmitted, the DACI can indicate the order of the PDCCHs. If 4 PDCCHs are transmitted, as shown in FIG. 45, the DACI has values of 0 to 3. The DACI may be included in a DCI field of the corresponding PDCCHs and signaled to the corresponding UE, or signaled to the UE through other signaling methods. A downlink assignment index (DAI) field used in LTE TDD can be used as a DACI field.

The DACI can indicate the number of PDSCHs (or the number of PDCCHs) in all DL CCs. For example, if the DACI indicates the number of PDCCHs in the example shown in FIG. 45, all the DACI values in the PDCCHs may be 4. When the DACI indicates the number of PDCCHs, the DACI can be applied to a case in which the UE transmits ACK/NACK in an ACK/NACK bundling mode. ACK/NACK bundling is a method of transmitting representative HARQ-ACK/NACK through a logical AND operation. For example, NACK is transmitted as a representative value when at least one of ACK/NACK results corresponds to NACK and ACK is transmitted as a representative value when all the ACK/NACK results correspond to ACK. If the number of PDCCHs successfully decoded by the UE is 3 although a DACI value indicating the total number of PDCCHs is 4, which means that one PDCCH is not decoded, NACK, DTX or NACK/DTX can be signaled as a representative value to the BS. Accordingly, the BS and the UE can be aware of a DTX status using the DACI. The method of transmitting NACK when DTX is generated is exemplary and a DTX status may be signaled by transmitting no information. The present invention is not limited by the DTX signaling scheme.

For facilitation of description, a case in which the DACI is used as a CC index counter is described. A DACI counter can be set such that it corresponds to a carrier indicator field (CIF) for cross-carrier scheduling. For example, if a CIF value is 3 bits, a DACI value may also be 3 bits. The DACI may be counted from a low frequency CC to a high frequency CC (or counted from a high frequency CC to a low frequency CC). Otherwise, the DACI may be circularly counted in ascending order from the primary carrier. If multiple PDCCHs are transmitted in one DL CC, the DACI can be counted from a low CCE index to a high CCE index. For example, when the lowest CCE index of PDCCH0 in DL CC#0 for a PDSCH of DL CC#1 is 10 and the lowest CCE index of PDCCH1 in DL CC#0 for a PDSCH of DL CC#2 is 20, PDCCH0 may have a DACI value lower than that of PDCCH1. Alternatively, a DACI value transmitted in each PDCCH may be determined by the network without a particular rule and transmitted. That is, the DACI may not conform to a specific rule.

The DACI may be defined as a combination with a DAI used in LTE TDD. For example, when 4 DAI statuses and 5 DACI statuses are present, a total of 20 combinations of DAI and DACI can be defined with indexes of 0 to 19. Even in this case, the present invention is applicable.

A primary objective of the DACI is to enable the UE to detect DTX. For example, if decoding of a PDCCH corresponding to DL CC#2 fails in the example of FIG. 45, UE#0 acquires DACI counter values 0, 1 and 3 through DCI0, DCI1 and DCI3, respectively. UE#0 may recognize that blind decoding of DCI2 has failed (i.e. enters a DTX status) because DACI=2 is missed and transmit the DTX status to the BS.

However, even when the DACI is used, UE#0 cannot be aware of whether or not blind decoding of the last DCI fails. In other words, when UE#0 fails to decode the last DCI even though the BS has transmitted the last DCI to UE#0, UE#0 cannot be aware of whether decoding of the last DCI fails or the BS does not transmit the last DCI. Referring to FIG. 45, when UE#0 fails to decode DCI3 although the BS has transmitted DCI3 in DL CC#3, UE#0 does not know whether DCI3 is present or decoding of DCI3 fails.

Therefore, the present embodiment proposes a method for correctly providing ACK/NACK (including DTX) states for all DL PDSCHs to the BS and UEs. Specifically, the present embodiment proposes a method of transmitting ACK/NACK information using a PUCCH resource corresponding to a PDCCH over which the last value of the DACI counter is transmitted.

FIG. 46 illustrates an embodiment according to the present invention. This embodiment shows a case in which the BS transmits 4 PDCCHs and UE#0 successfully decodes all PDCCHs. In this case, HARQ-ACK/NACK information for 4 PDSCHs transmitted through 4 DL CCs is delivered through PUCCH resource 34 corresponding to the lowest CCE index 4 of a PDCCH having the largest DACI value 3 from among the detected PDCCHs. If the DACI is counted in reverse order (e.g. 3, 2, 1, 0), the HARQ-ACK/NACK information can be transmitted through PUCCH resource 2 corresponding to the lowest CCE index 2 of the first PDCCH (DL CC#0).

FIG. 47 illustrates a case in which UE#0 successfully decodes a PDCCH corresponding to DCI2 and fails to decode a PDCCH corresponding to DCI3. The BS will expect to receive HARQ-ACK/NACK information through PUCCH resource 34 from UE#0 on the assumption that UE#0 successfully decodes DCI3. However, when UE#0 successfully decodes DCI2 (it is not necessary to consider

whether or not DCI0 and DCI1 are successfully decoded because UE#0 can recognize it through DACI) but fails to decode DCI3, UE#0 transmits the HARQ-ACK/NACK information through PUCCH resource 20 corresponding to DCI2. Accordingly, the BS can recognize whether DTX was occurred as for the last DCI3 through the transmitted resource.

FIG. 48 illustrates a case in which UE#0 fails to decode DCI0, DCI2 and DCI3. UE#0 can recognize whether decoding of DCI0 fails through a received DACI because it has successfully decoded DCI1. However, UE#0 cannot be aware of whether DTX is generated for DCI2 and DCI3. UE#0 transmits HARQ-ACK/NACK information through PUCCH resource 16 corresponding to the lowest CCE index 6 of a PDCCH having the largest DACI value 1 from among detected PDCCHs although it does not know whether DTX is generated for DCI2 and DCI3. Accordingly, the BS can recognize that DTX is generated for DCI2 and DCI3.

FIG. 49 illustrates a case in which 2 PDCCHs are transmitted through DL CC#3 on the assumption that the DACI is counted from a low CCE index to a high CCE index when a plurality of PDCCHs is transmitted through one DL CC. In this case, UE#0 transmits HARQ-ACK/NACK information through PUCCH resource 36 corresponding to the lowest CCE index 6 of a PDCCH having the largest DACI value 3 from among detected PDCCHs.

FIG. 50 illustrates a case in which 2 PDCCHs are transmitted through DL CC#3 and a DCI having a lower CCE index has a larger DACI value. In this case, UE#0 transmits HARQ-ACK/NACK information through PUCCH resource 34 corresponding to the lowest CCE index 4 of a PDCCH having the largest DACI value 3 from among detected PDCCHs.

A description will be given of a case in which PUCCHs for DL CCs are defined such that the PUCCHs are shared with reference to FIGS. 51 and 52.

FIG. 51 illustrates a case in which UE#0 successfully decodes all 4 PDCCHs for DL CCs while the PDCCHs are shared. In this case, UE#0 transmits HARQ-ACK/NACK information through PUCCH resource 4 corresponding to the lowest CCE index 4 of a PDCCH having the largest DACI value 3 from among the detected PDCCHs.

FIG. 52 illustrates a case in which UE#0 fails to decode DCI3 with DACI=3. In this case, UE#0 transmits HARQ-ACK/NACK information through PUCCH resource 0 corresponding to the lowest CCE index 0 of a PDCCH having the largest DACI value 2 from among the detected PDCCHs. Accordingly, the BS can recognize that DTX is generated for DCI3.

FIG. 53 illustrates a case in which PUCCH resources for DL CCs partially overlap. UE#0 transmits HARQ-ACK/NACK information in the same manner as the above cases.

Another scheme for solving a DTX problem for the last DACI value will now be described. Specifically, a scheme of simultaneously using a parameter indicating a PDCCH counter value and a parameter indicating the number of PDCCHs is proposed.

For example, if DACI0 serves as a PDCCH counter (e.g. DACI counts 0 to 7 when it is 3 bits), DACI1 can transmit information indicating the number of allocated PDCCHs (or PDSCHs) (e.g. DACI transmits 1 to 8 when it is 3 bits; 0 need not be transmitted). For example, when 4 PDCCHs are transmitted, each PDCCH may carry the following information.

DCI0: DACI0=0, DACI1=4
DCI1: DACI0=1, DACI1=4

DCI2: DACI0=2, DACI1=4

DCI3: DACI0=3, DACI1=4

Here, DACI1 can be additionally defined with DACI0. Alternatively, DACI1 may be transmitted over one or more of the PDCCHs. Alternatively, if one of DCIs is limited such that cross-carrier scheduling is not permitted therefor, the CIF field of the corresponding DCI can be used to carry DACI1. Alternatively, DACI0 and DACI1 can be transmitted through RRC signaling or broadcasting signaling.

Another method for solving the DTX problem in the last DACI value uses RRC signaling. In this method, a specific UE can be assigned a unique PUCCH resource through RRC signaling. The PUCCH resource may be a resource shared by multiple UEs or a resource allocated for SPS or ACK/NACK repetition. When DTX is generated in at least one PDCCH, the specific UE transmits HARQ-ACK/NACK information through the PUCCH resource assigned thereto through RRC signaling. When no DTX is generated, the UE performs dynamic ACK/NACK operation in an implicit manner. Conversely, the UE may transmit the HARQ-ACK/NACK information using the PUCCH resource allocated thereto when no DTX is generated and may implicitly perform the dynamic ACK/NACK operation when DTX is generated. In this case, the DACI may simply indicate the number of transmitted PDCCHs. When the DACI indicates the number of transmitted PDCCHs, it is impossible to know which PDCCH is lost and only whether DTX is generated can be recognized. The implicit rule for the dynamic ACK/NACK operation is to transmit HARQ-ACK/NACK information using a PUCCH resource corresponding to the lowest CCE index of a PDCCH having the largest CCE index among PDCCH(s) of the largest CC index, a PUCCH resource corresponding to the lowest CCE index of a PDCCH having the lowest CCE index among PDCCH(s) of the largest CC index, a PUCCH resource corresponding to the lowest CCE index of a PDCCH having the lowest CCE index, among PDCCH(s) of the lowest CC index, or a PUCCH resource corresponding to the lowest CCE index of a PDCCH having the largest CCE index among PDCCH(s) of the lowest CC index.

If the DACI is defined as a counter, it is possible to perform implicit mapping using the lowest CCE index of a PDCCH having the largest DACI value.

FIG. 54 illustrates a case in which a PUCCH resource is defined by the lowest CCE index of a PDCCH having the lowest CCE index among PDCCH(s) of the largest CC index, according to the implicit rule and DTX is not generated for any PDCCH. Since DTX is not generated, UE#0 transmits HARQ-ACK/NACK information through PUCCH resource 34 corresponding to the lowest CCE index 4 of a PDCCH having the largest DACI value 3 from among detected PDCCHs. The HARQ-ACK/NACK information may be information bundled for control information of all PDSCHs.

FIG. 55 illustrates a case in which DTX is generated for DCI1. In this case, UE#0 recognizes that DTX is generated for a DCI corresponding to DACI=2 because UE#0 has successfully performed decoding for DACI=0, DACI=1 and DACI=3. UE#0 transmits HARQ-ACK/NACK information through RRC-sigaled PUCCH resource 100 because DTX has been generated. The HARQ-ACK/NACK information may be information bundled for control information of all PDSCHs.

FIG. 56 illustrates a case in which UE#0 fails to decode a PDCCH having the last DACI value. In this case, UE#0 cannot be aware of whether DTX is generated for a DCI corresponding to DACI=3. Accordingly, UE#0 recognizes

that DTX is not generated and transmits HARQ-ACK/NACK information through PUCCH resource 36 corresponding to the lowest CCE index 6 of a PDCCH having the largest DACI value 2 from among detected PDCCHs. The BS expects to receive HARQ-ACK/NACK information (combined ACK/NACK) through PUCCH resource 34 corresponding to DCI2, which corresponds to the PDCCH having the largest DACI value, or RRC-sigaled PUCCH resource 100. However, UE#0 transmits the HARQ-ACK/NACK information through PUCCH resource 36 corresponding to DCI3, and thus the BS recognizes that DTX is generated for DCI2.

The above-mentioned methods may be combined. For example, the format adaptation and the schemes for detecting DTX (i.e. the scheme of using the CCE index of the PDCCH carrying the last DACI value, the scheme of simultaneously transmitting DACI0 and DACI1, and the scheme of using RRC signaling) can be combined.

FIG. 57 is a block diagram showing configurations of a BS and a UE.

Referring to FIG. 57, a wireless communication system includes a BS 110 and a UE 120. The BS includes a processor 112, a memory 114, an RF unit 116. The processor 112 may be configured to implement the procedures and/or methods proposed by the present invention. The memory 114 is connected to the processor 112 and stores information related to operations of the processor 112. The RF unit 116 is connected to the processor 112, transmits and/or receives an RF signal. The UE 120 includes a processor 122, a memory 124, and an RF unit 126. The processor 122 may be configured to implement the procedures and/or methods proposed by the present invention. The memory 124 is connected to the processor 122 and stores information related to operations of the processor 122. The RF unit 126 is connected to the processor 122, transmits and/or receives an RF signal. The BS 110 and/or UE 120 may include a single antenna or multiple antennas.

The embodiments of the present invention described hereinbelow are combinations of elements and features of the present invention. The elements or features may be considered selective unless otherwise mentioned. Each element or feature may be practiced without being combined with other elements or features. Further, an embodiment of the present invention may be constructed by combining parts of the elements and/or features. Operation orders described in embodiments of the present invention may be rearranged. Some constructions of any one embodiment may be included in another embodiment and may be replaced with corresponding constructions of another embodiment. It will be obvious to those skilled in the art that claims that are not explicitly cited in each other in the appended claims may be presented in combination as an embodiment of the present invention or included as a new claim by a subsequent amendment after the application is filed.

In the embodiments of the present invention, a description is made centering on a data transmission and reception relationship among a BS, a relay, and an MS. In some cases, a specific operation described as performed by the BS may be performed by an upper node of the BS. Namely, it is apparent that, in a network comprised of a plurality of network nodes including a BS, various operations performed for communication with an MS may be performed by the BS, or network nodes other than the BS. The term 'BS' may be replaced with the term 'fixed station', 'Node B', 'enhanced Node B (eNode B or eNB)', 'access point', etc.

The term 'UE' may be replaced with the term 'Mobile Station (MS)', 'Mobile Subscriber Station (MSS)', 'mobile terminal', etc.

The embodiments of the present invention may be achieved by various means, for example, hardware, firm-ware, software, or a combination thereof. In a hardware configuration, the methods according to the embodiments of the present invention may be achieved by one or more Application Specific Integrated Circuits (ASICs), Digital Signal Processors (DSPs), Digital Signal Processing Devices (DSPDs), Programmable Logic Devices (PLDs), Field Programmable Gate Arrays (FPGAs), processors, controllers, microcontrollers, microprocessors, etc.

In a firmware or software configuration, the embodiments of the present invention may be implemented in the form of a module, a procedure, a function, etc. For example, software code may be stored in a memory unit and executed by a processor. The memory unit is located at the interior or exterior of the processor and may transmit and receive data to and from the processor via various known means.

Those skilled in the art will appreciate that the present invention may be carried out in other specific ways than those set forth herein without departing from the spirit and essential characteristics of the present invention. The above embodiments are therefore to be construed in all aspects as illustrative and not restrictive. The scope of the invention should be determined by the appended claims and their legal equivalents, not by the above description, and all changes coming within the meaning and equivalency range of the appended claims are intended to be embraced therein.

INDUSTRIAL APPLICABILITY

The present invention can be used for a UE, a BS or other devices in a wireless communication system. Specifically, the present invention is applicable to a method for transmitting uplink control information and an apparatus therefor.

The invention claimed is:

1. A method for transmitting control information through a physical uplink control channel (PUCCH) at a user equipment (UE) in a wireless communication system, the method comprising:

modulating control information bits to generate N_1 modulation symbols, wherein N_1 is twice of a number of subcarriers in one resource block (RB);

block-wise multiplying the first $N_1/2$ modulation symbols of the N_1 modulation symbols by each element of a first orthogonal code of spreading factor $M-1$ to generate a first plurality of sequences, wherein M is a plural number;

block-wise multiplying the second $N_1/2$ modulation symbols of the N_1 modulation symbols by each element of a second orthogonal code of spreading factor $M[-1]$ to generate a second plurality of sequences; and

transmitting the first and second plurality of sequences in a subframe,

wherein each sequence of the first plurality of sequences is mapped to a corresponding single carrier frequency division multiple access (SC-FDMA) symbol in a 1st slot of the subframe, and each sequence of the second plurality of sequences is mapped to a corresponding SC-FDMA symbol in a 2nd slot of the subframe, wherein each sequence of the first and second plurality of sequences [is] includes a respective discrete [fourier] Fourier transformed sequence.

2. The method of claim 1, wherein the first $N_1/2$ modulation symbols are the first half of the N_1 modulation

symbols, and the second $N_1/2$ modulation symbols are the second half of the N_1 modulation symbols.

3. The method of claim 1, wherein the first orthogonal code and the second orthogonal code are independently determined for each slot.

4. The method of claim 1, wherein indexes of the SC-FDMA symbols, through which the first plurality of sequences are transmitted, in slot 0 are 0, 2, 3, 4 and 6 in a normal cyclic prefix (CP) case and 0, 1, 2, 4 and 5 in an extended CP case, and the first orthogonal code of spreading factor M is selected from the following table:

	[1 1 1 1 1]
[1	$e^{j2\pi/5}$ $e^{j4\pi/5}$ $e^{j6\pi/5}$ $e^{j8\pi/5}$]
[1	$e^{j4\pi/5}$ $e^{j8\pi/5}$ $e^{j2\pi/5}$ $e^{j6\pi/5}$]
[1	$e^{j6\pi/5}$ $e^{j2\pi/5}$ $e^{j8\pi/5}$ $e^{j4\pi/5}$]
[1	$e^{j8\pi/5}$ $e^{j6\pi/5}$ $e^{j4\pi/5}$ $e^{j2\pi/5}$].

5. The method of claim 1, wherein indexes of the SC-FDMA symbols, through which the second plurality of sequences are transmitted, in slot 1 are 0, 2, 3 and 4 in a normal cyclic prefix (CP) case and 0, 1, 2 and 4 in an extended CP case, and the second orthogonal code of spreading factor $M-1$ is selected from the following table:

	[1 1 1 1]
	[1 -1 1 -1]
	[1 1 -1 -1]
	[1 -1 -1 1].

6. The method of claim 1, wherein the control information bits include multiple ACK/NACK information for a plurality of downlink data.

7. An User equipment (UE) configured to transmit control information through a PUCCH in a wireless communication system, the UE comprising:

[a radio frequency (RF) unit; and
a processor,

wherein the processor is configured to:]

a modulator configured to modulate control information bits to generate N_1 modulation symbols, wherein N_1 is twice of a number of sub-carriers in one resource block (RB),

a spreader configured to block-wise multiply the first $N_1/2$ modulation symbols of the N_1 modulation symbols by each element of a first orthogonal code of spreading factor M to generate a first plurality of sequences, wherein M is a plural number,

the spreader configured to block-wise multiply the second $N_1/2$ modulation symbols of the N_1 modulation symbols by each element of a second orthogonal code of spreading factor $M-1$ to generate second plurality of sequences, and

a transmitter configured to transmit the first and second plurality of sequences [on] in a subframe, each sequence of the first plurality of sequences is mapped to a corresponding single carrier frequency division multiple access (SC-FDMA) symbol in a 1st slot of the subframe, and each sequence of the second plurality of sequences is mapped to a corresponding SC-FDMA symbol in a 2nd slot of the subframe, wherein each sequence of the first and second plurality of sequences [is] includes a respective discrete [fourier] Fourier transformed sequence.

45

8. The UE of claim 7, wherein the first $N_1/2$ modulation symbols are the first half of the N_1 modulation symbols, and the second $N_1/2$ modulation symbols are the second half of the N_1 modulation symbols.

9. The UE of claim 7, wherein the first orthogonal code and the second orthogonal code are independently determined for each slot.

10. The UE of claim 7, wherein indexes of the SC-FDMA symbols, through which the first plurality of sequences are transmitted, in slot 0 are 0, 2, 3, 4 and 6 in a normal cyclic prefix (CP) case and 0, 1, 2, 4 and 5 in an extended CP case, and the first orthogonal code of spreading factor M is selected from the following table:

	[1 1 1 1]
[1	$e^{j2\pi/5}$ $e^{j4\pi/5}$ $e^{j6\pi/5}$ $e^{j8\pi/5}$]
[1	$e^{j4\pi/5}$ $e^{j8\pi/5}$ $e^{j2\pi/5}$ $e^{j6\pi/5}$]
[1	$e^{j6\pi/5}$ $e^{j2\pi/5}$ $e^{j8\pi/5}$ $e^{j4\pi/5}$]
[1	$e^{j8\pi/5}$ $e^{j6\pi/5}$ $e^{j4\pi/5}$ $e^{j2\pi/5}$].

11. The UE of claim 7, wherein indexes of the SC-FDMA symbols, through which the second plurality of sequences are transmitted, in slot 1 are 0, 2, 3 and 4 in a normal cyclic prefix (CP) case and 0, 1, 2 and 4 in an extended CP case, and the second orthogonal code of spreading factor $M-1$ is selected from the following table:

	[1 1 1 1]
	[1 -1 1 -1]
	[1 1 -1 -1]
	[1 -1 -1 1].

12. The UE of claim 7, wherein the control information bits include multiple ACK/NACK information for a plurality of downlink data.

13. The method of claim 1, wherein M is same as a number of SC-FDMA symbols to which for the first plurality of sequences is mapped.

14. The UE of claim 7, wherein M is same as a number of SC-FDMA symbols to which for the first plurality of sequences is mapped.

15. A method for a device to transmit control information in a wireless communication system, the method comprising: modulating control information to provide N modulation symbols;

46

spreading a block of modulation symbols using an orthogonal sequence with a spreading factor M to provide a length- L spread modulation symbol sequence,

wherein the block of modulation symbols includes L/M modulation symbols among the N modulation symbols, and L is a number of subcarriers in a resource block (RB);

discrete fourier transforming the length- L spread modulation symbol sequence to provide a length- L complex-valued symbol sequence; and

transmitting the length- L complex-valued symbol sequence through a corresponding one of single carrier frequency division multiple access (SC-FDMA) symbols for a physical uplink control channel (PUCCH).

16. The method of claim 15, wherein M is 2.

17. The method of claim 15, wherein L is 12.

18. The method of claim 15, wherein the control information includes multiple ACK/NACKs for a plurality of data.

19. A device for use in a wireless communication system, the device comprising:

a modulator configured to modulate control information to provide N modulation symbols,

a spreader configured to spread a block of modulation symbols using an orthogonal sequence with a spreading factor M to provide a length- L spread modulation symbol sequence,

wherein the block of modulation symbols includes L/M modulation symbols among the N modulation symbols, and L is a number of subcarriers in a resource block (RB),

a precoder configured to discrete fourier transform the length- L spread modulation symbol sequence to provide a length- L complex-valued symbol sequence, and

a transmitter configured to transmit the length- L complex-valued symbol sequence through a corresponding one of single carrier frequency division multiple access (SC-FDMA) symbols for a physical uplink control channel (PUCCH).

20. The device of claim 19, wherein M is 2.

21. The device of claim 19, wherein L is 12.

22. The device of claim 19, wherein the control information includes multiple ACK/NACKs for a plurality of data.

* * * * *