



US00RE49227E

(19) **United States**
(12) **Reissued Patent**
Peron

(10) **Patent Number: US RE49,227 E**
(45) **Date of Reissued Patent: Oct. 4, 2022**

(54) **MEDICAL DRESSING**

(56) **References Cited**

(71) Applicant: **Smith & Nephew PLC**, Watford (GB)

U.S. PATENT DOCUMENTS

(72) Inventor: **Yannick Louis Peron**, East Yorkshire (GB)

1,066,934 A	7/1913	Manney	
2,613,696 A *	10/1952	MacIntyre	139/418
2,682,873 A	7/1954	Evans et al.	
3,342,183 A *	9/1967	Edenbaum	604/307
3,568,675 A	3/1971	Harvey	
D235,737 S	7/1975	Paone et al.	
D240,199 S	6/1976	Perfect	
4,219,019 A	8/1980	Coates	
4,228,798 A	10/1980	Deaton	
4,252,119 A	2/1981	Coates	
4,341,207 A	7/1982	Steer et al.	
4,360,015 A	11/1982	Mayer	
4,360,021 A	11/1982	Stima	
D267,510 S *	1/1983	Golub	D24/189
4,499,896 A	2/1985	Heinecke	
4,561,435 A	12/1985	McKnight et al.	
4,564,010 A *	1/1986	Coughlan et al.	604/307
4,587,146 A *	5/1986	Anhauser et al.	428/42.2
4,627,429 A *	12/1986	Tsuk	604/307
4,699,134 A	10/1987	Samuelsen	
D292,826 S *	11/1987	Sproles	D24/189
4,759,354 A	7/1988	Quarfoot	
4,798,603 A	1/1989	Meyer et al.	
4,808,172 A *	2/1989	Murata	604/306
4,867,150 A	9/1989	Gilbert	
4,872,450 A	10/1989	Austad	
4,875,473 A	10/1989	Alvarez	
4,882,213 A	11/1989	Gaddis et al.	
4,917,112 A *	4/1990	Kalt	A61F 13/023 128/888

(73) Assignee: **Smith & Nephew PLC**, Watford (GB)

(21) Appl. No.: **29/709,413**

(22) Filed: **Mar. 19, 2020**

Related U.S. Patent Documents

Reissue of:

(64) Patent No.: **Des. 679,820**
Issued: **Apr. 9, 2013**
Appl. No.: **29/389,783**
Filed: **Apr. 15, 2011**

U.S. Applications:

(60) Continuation of application No. 29/639,290, filed on Mar. 5, 2018, now Pat. No. Re. 47,645, which is a continuation of application No. 29/548,270, filed on Dec. 11, 2015, now Pat. No. Re. 46,778, which is a division of application No. 29/510,717, filed on Dec. 2, 2014, now Pat. No. Re. 46,289, which is an application for the reissue of Pat. No. Des. 679,820.

(30) **Foreign Application Priority Data**

Oct. 15, 2010 (GB) 4017442
Oct. 15, 2010 (GB) 4017443

(51) **LOC (13) Cl.** **24-04**

(52) **U.S. Cl.**
USPC **D24/184**

(58) **Field of Classification Search**
USPC D24/189
CPC A61F 13/02; A61M 1/009; A61M 27/00;
A61M 1/0088

See application file for complete search history.

4,969,880 A	11/1990	Zamierowski	
4,972,829 A	11/1990	Knerr	
4,997,425 A	3/1991	Shioya et al.	
5,052,381 A *	10/1991	Gilbert et al.	602/52
5,056,510 A *	10/1991	Gilman	602/52
5,080,661 A	1/1992	Lavender et al.	
5,134,994 A	8/1992	Say	
5,149,331 A	9/1992	Ferdman et al.	
5,152,757 A	10/1992	Eriksson	
5,176,663 A	1/1993	Svedman et al.	
5,218,973 A	6/1993	Weaver et al.	
5,261,893 A	11/1993	Zamierowski	
5,264,218 A	11/1993	Rogozinski	
5,266,371 A *	11/1993	Sugii et al.	428/41.5
5,322,695 A	6/1994	Shah et al.	

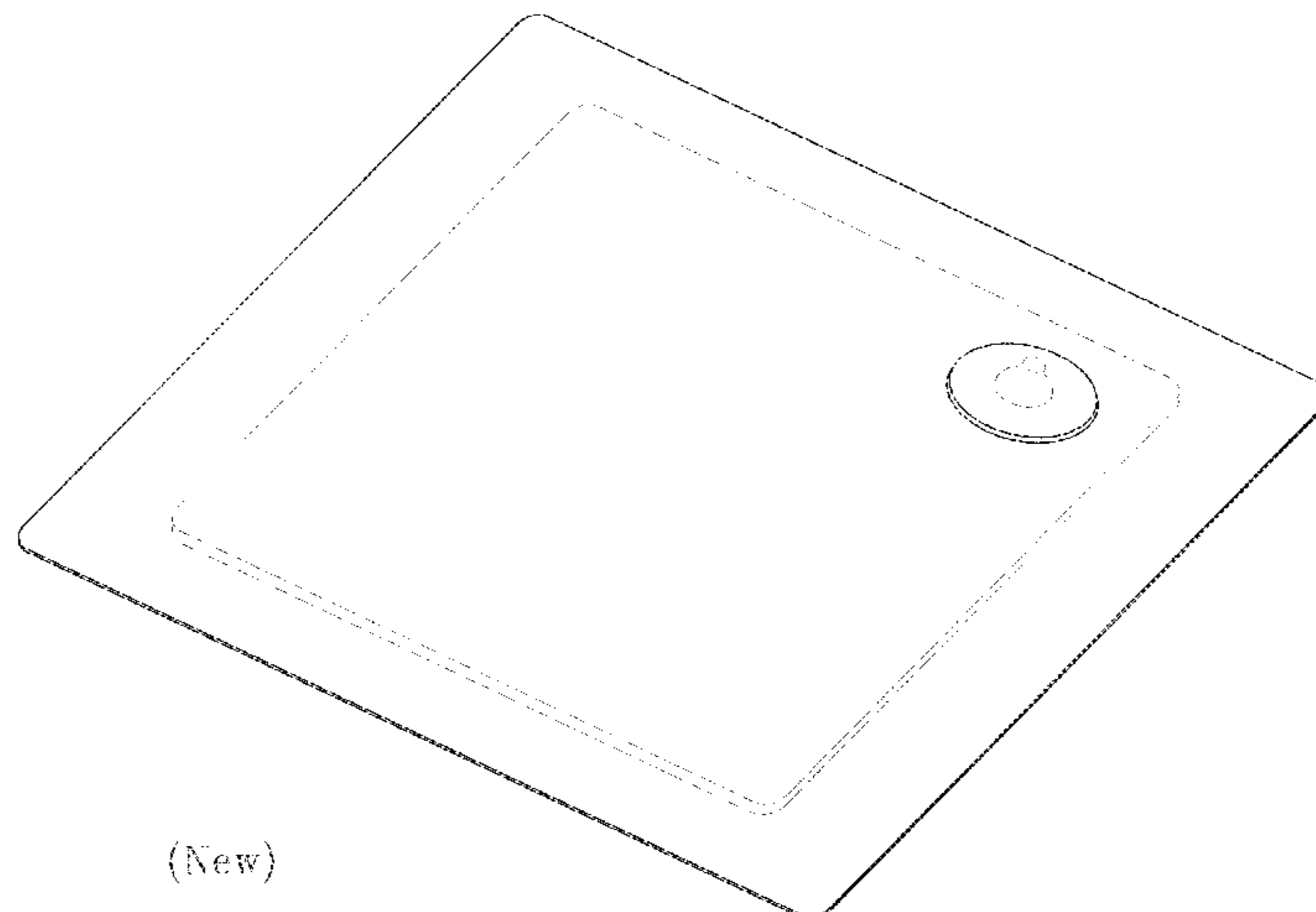

(New)

US RE49,227 E

5,336,209 A	8/1994	Porzilli		D481,459 S	10/2003	Nahm	
D352,463 S	11/1994	Kubo		6,648,862 B2	11/2003	Watson	
D352,782 S *	11/1994	Kirk et al.	D24/189	6,680,113 B1	1/2004	Lucast et al.	
D357,742 S *	4/1995	Peery et al.	D24/189	6,685,681 B2	2/2004	Lockwood et al.	
5,437,651 A	8/1995	Todd et al.		6,752,794 B2	6/2004	Lockwood et al.	
5,445,604 A	8/1995	Lang		6,755,807 B2	6/2004	Risk et al.	
D362,505 S *	9/1995	Fabricant	D24/189	D495,056 S *	8/2004	Watanabe	D24/189
5,486,158 A	1/1996	Samuelson		6,794,554 B2	9/2004	Sessions et al.	
5,496,605 A	3/1996	Augst et al.		6,797,855 B2	9/2004	Worthley	
D369,907 S *	5/1996	Sayovitz et al.	D5/53	6,814,079 B2	11/2004	Heaton et al.	
D370,127 S *	5/1996	Bonaddio et al.	D5/58	6,838,589 B2	1/2005	Liedtke et al.	
5,527,293 A	6/1996	Zamierowski		6,855,135 B2	2/2005	Lockwood et al.	
D372,098 S *	7/1996	Lattin et al.	D24/189	D504,953 S	5/2005	Ryan	
5,549,584 A	8/1996	Gross		D506,547 S	6/2005	Cruz et al.	
5,593,395 A	1/1997	Martz		6,936,037 B2	8/2005	Bubb et al.	
5,599,289 A	2/1997	Castellana		D509,299 S *	9/2005	Watanabe	D24/189
5,616,387 A	4/1997	Augst et al.		6,951,553 B2	10/2005	Bubb et al.	
5,624,423 A	4/1997	Anjur et al.		6,974,428 B2	12/2005	Knutson et al.	
5,633,007 A	5/1997	Webb et al.		D516,217 S	2/2006	Brown et al.	
5,636,643 A	6/1997	Argenta et al.		7,004,915 B2	2/2006	Boynton et al.	
5,645,081 A	7/1997	Argenta et al.		7,005,556 B1	2/2006	Becker et al.	
D382,343 S *	8/1997	Wandell et al.	D24/189	7,030,288 B2	4/2006	Liedtke et al.	
D384,745 S *	10/1997	Lattin et al.	D24/189	7,041,868 B2	5/2006	Greene et al.	
D385,038 S *	10/1997	Shultz	D24/189	D522,657 S	6/2006	Murphy et al.	
5,681,579 A	10/1997	Freeman		7,108,683 B2	9/2006	Zamierowski	
D389,581 S *	1/1998	Fein	D24/189	7,137,968 B1	11/2006	Burrell et al.	
5,713,881 A	2/1998	Rezai et al.		D537,944 S	3/2007	Eda et al.	
5,714,225 A	2/1998	Hansen et al.		D537,948 S	3/2007	Smith	
5,733,305 A	3/1998	Fleischmann		7,195,624 B2	3/2007	Lockwood et al.	
D393,591 S	4/1998	Baryshyan		D543,691 S	6/2007	Payne et al.	
5,759,570 A	6/1998	Arnold		D544,092 S	6/2007	Lewis	
D396,954 S	8/1998	Iversen et al.		D544,607 S	6/2007	Henry et al.	
D396,955 S	8/1998	Iversen et al.		D545,055 S	6/2007	Lieberman et al.	
D396,956 S	8/1998	Iversen et al.		D546,952 S	7/2007	May	
5,792,090 A	8/1998	Ladin		D548,347 S	8/2007	Ichino et al.	
5,810,755 A	9/1998	LeVeen et al.		D548,954 S	8/2007	Andersen et al.	
D400,249 S	10/1998	Holubar et al.		D551,769 S	9/2007	Skwarek et al.	
D403,774 S	1/1999	Laughlin et al.		D554,266 S	10/2007	Striepe et al.	
D406,899 S	3/1999	Cottle		7,288,745 B2	10/2007	Colonna	
5,885,237 A	3/1999	Kadash et al.		7,291,762 B2	11/2007	Flick	
D408,625 S	4/1999	Barker		D556,444 S	12/2007	Ipsen et al.	
D408,920 S	4/1999	Dunshee et al.		7,317,954 B2	1/2008	McGreevy	
5,899,893 A	5/1999	Dyer et al.		7,335,809 B2	2/2008	Riesinger	
5,928,265 A	7/1999	Fleischmann		7,338,482 B2	3/2008	Lockwood et al.	
5,958,420 A	9/1999	Jenson		D571,922 S *	6/2008	Freeland	D24/189
D414,925 S	10/1999	Holland		7,381,859 B2	6/2008	Hunt et al.	
D415,836 S	10/1999	Dunshee et al.		D572,367 S *	7/2008	Freeland	D24/189
5,964,723 A	10/1999	Augustine		D572,588 S	7/2008	Osborn et al.	
5,981,822 A	11/1999	Addison		D572,824 S *	7/2008	Propp	D24/189
5,985,990 A	11/1999	Kantner et al.		D572,825 S *	7/2008	Freeland	D24/189
5,998,694 A *	12/1999	Jensen et al.	602/57	7,401,703 B2	7/2008	McMichael et al.	
6,010,527 A	1/2000	Augustine et al.		7,438,705 B2	10/2008	Karpowicz et al.	
6,011,194 A	1/2000	Buglino et al.		D580,285 S	11/2008	Hendrickson et al.	
D423,102 S	4/2000	Mertenant		D585,135 S	1/2009	Mori et al.	
D424,699 S *	5/2000	Allen	D24/189	D585,137 S	1/2009	Onoda et al.	
6,071,267 A	6/2000	Zamierowski		D585,543 S	1/2009	Yodfat et al.	
6,087,549 A	7/2000	Flick		D586,466 S	2/2009	Smith et al.	
6,117,111 A	9/2000	Fleischmann		D587,376 S	2/2009	Takano et al.	
6,136,796 A	10/2000	Kozak		D587,901 S	3/2009	Pidgeon et al.	
D434,150 S	11/2000	Tumey et al.		D588,160 S	3/2009	Beale et al.	
6,142,982 A	11/2000	Hunt et al.		D589,798 S	4/2009	Liipola	
D439,341 S	3/2001	Tumey et al.		D590,841 S	4/2009	Muhlenberend	
6,203,563 B1	3/2001	Fernandez		7,518,031 B2	4/2009	Liedtke et al.	
6,255,552 B1	7/2001	Cummings et al.		7,531,711 B2	5/2009	Sigurjonsson et al.	
6,291,050 B1	9/2001	Cree et al.		D594,114 S	6/2009	Locke et al.	
6,293,281 B1	9/2001	Shultz et al.		D596,030 S	7/2009	Liipola	
D449,891 S	10/2001	Moro		D598,472 S	8/2009	Andersen et al.	
6,345,623 B1	2/2002	Heaton et al.		7,569,742 B2	8/2009	Haggstrom et al.	
6,350,339 B1	2/2002	Sessions		D600,354 S *	9/2009	Sachi	D24/189
D456,514 S	4/2002	Brown et al.		D601,692 S	10/2009	Tout et al.	
D459,078 S	6/2002	Tondino		D602,284 S	10/2009	Pidgeon et al.	
6,398,767 B1	6/2002	Fleischmann		D602,582 S	10/2009	Pidgeon et al.	
6,458,109 B1	10/2002	Henley et al.		D602,583 S	10/2009	Pidgeon et al.	
6,468,199 B1	10/2002	Satou et al.		D602,584 S	10/2009	Pidgeon et al.	
D469,176 S	1/2003	Hall et al.		D604,424 S *	11/2009	Coubetergues	D24/189
6,553,998 B2	4/2003	Heaton et al.		7,611,500 B1	11/2009	Lina et al.	
D475,132 S	5/2003	Randolph		7,615,036 B2	11/2009	Joshi et al.	
D475,454 S	6/2003	Gillespie et al.		D605,299 S *	12/2009	Iwahashi et al.	D24/189
D477,086 S *	7/2003	Tsuruda et al.	D24/189	D607,202 S	1/2010	Pidgeon et al.	

US RE49,227 E

7,645,269 B2	1/2010	Zamierowski	8,808,274 B2	8/2014	Hartwell
D609,922 S *	2/2010	Bridges et al. D5/53	D713,967 S *	9/2014	Adoni D24/189
7,717,313 B2	5/2010	Criscuolo et al.	8,864,748 B2	10/2014	Coulthard et al.
7,722,582 B2	5/2010	Lina et al.	8,905,985 B2	12/2014	Allen et al.
D616,980 S	6/2010	MacDonald et al.	8,951,235 B2	2/2015	Allen et al.
D617,094 S	6/2010	Pidgeon et al.	9,061,095 B2	6/2015	Adie et al.
D618,810 S *	6/2010	Tanigawa et al. D24/189	RE45,864 E	1/2016	Peron
7,745,681 B1	6/2010	Ferguson	RE46,289 E	1/2017	Peron
D620,122 S *	7/2010	Cotton D24/189	9,770,368 B2	9/2017	Robinson et al.
D620,123 S *	7/2010	Igwebuike D24/189	RE46,778 E	4/2018	Peron
7,754,937 B2	7/2010	Boehringer et al.	RE47,644 E	10/2019	Peron
7,758,554 B2	7/2010	Lina et al.	RE47,645 E	10/2019	Peron
7,759,537 B2	7/2010	Bishop et al.	2001/0027285 A1	10/2001	Heinecke et al.
7,759,538 B2	7/2010	Fleischmann	2002/0002209 A1	1/2002	Mork
7,759,539 B2	7/2010	Shaw et al.	2003/0219469 A1	11/2003	Johnson et al.
7,763,769 B2	7/2010	Johnson et al.	2004/0064111 A1	4/2004	Lockwood et al.
7,775,998 B2	8/2010	Riesinger	2004/0167482 A1	8/2004	Watson
7,776,028 B2	8/2010	Miller et al.	2004/0241214 A1	12/2004	Kirkwood et al.
7,779,625 B2	8/2010	Joshi et al.	2005/0113733 A1	5/2005	Liedtke et al.
7,790,945 B1	9/2010	Watson, Jr.	2005/0131327 A1	6/2005	Lockwood et al.
7,790,946 B2	9/2010	Mulligan	2005/0143697 A1	6/2005	Riesinger
7,794,438 B2	9/2010	Henley et al.	2005/0181163 A1	8/2005	Kose
7,803,980 B2	9/2010	Griffiths et al.	2006/0009744 A1	1/2006	Erdman et al.
D625,017 S *	10/2010	Iwahashi et al. D24/189	2006/0142687 A1	6/2006	Liedtke et al.
D625,018 S *	10/2010	Smith et al. D24/189	2006/0178608 A1	8/2006	Stapf
D625,740 S	10/2010	Varini	2006/0241689 A1	10/2006	Leiboff et al.
D625,801 S	10/2010	Pidgeon et al.	2007/0142761 A1	6/2007	Aali
7,811,269 B2	10/2010	Boynton et al.	2007/0276195 A1	11/2007	Xu et al.
7,815,616 B2	10/2010	Boehringer et al.	2007/0276309 A1	11/2007	Xu et al.
7,838,717 B2	11/2010	Haggstrom et al.	2008/0033400 A1	2/2008	Holper et al.
D629,502 S	12/2010	Au et al.	2008/0071216 A1	3/2008	Locke et al.
D630,313 S	1/2011	Pidgeon et al.	2008/0095979 A1	4/2008	Hatanaka et al.
D630,725 S	1/2011	Pidgeon et al.	2008/0167593 A1	7/2008	Fleischmann
D631,166 S *	1/2011	Leffew et al. D24/189	2008/0213344 A1	9/2008	McCarthy et al.
7,880,050 B2	2/2011	Robinson et al.	2008/0300555 A1	12/2008	Olson et al.
7,896,823 B2	3/2011	Mangrum et al.	2009/0099519 A1	4/2009	Kaplan
7,896,856 B2	3/2011	Petrosenko et al.	2009/0130186 A1	5/2009	McCarthy et al.
7,922,703 B2	4/2011	Riesinger	2009/0177136 A1	7/2009	Liedtke et al.
7,951,100 B2	5/2011	Hunt et al.	2009/0223989 A1	9/2009	Gelardi
D639,441 S	6/2011	Sferle	2009/0227969 A1	9/2009	Jaeb et al.
7,959,624 B2	6/2011	Riesinger	2009/0240185 A1	9/2009	Jaeb et al.
7,964,766 B2	6/2011	Blott et al.	2009/0240218 A1	9/2009	Braga et al.
7,976,519 B2	7/2011	Bubb et al.	2009/0275872 A1	11/2009	Addison et al.
D642,594 S	8/2011	Mattson et al.	2009/0281471 A1 *	11/2009	Iwahashi et al. 602/54
D644,318 S	8/2011	MacDonald et al.	2009/0293887 A1	12/2009	Wilkes et al.
D644,330 S	8/2011	Pfeiffer et al.	2009/0299251 A1	12/2009	Buan
8,007,481 B2	8/2011	Schuessler et al.	2009/0299306 A1	12/2009	Buan
D645,137 S	9/2011	Gonzalez	2009/0299340 A1	12/2009	Kazala et al.
D648,353 S	11/2011	Mattson et al.	2009/0299341 A1	12/2009	Kazala et al.
D650,894 S	12/2011	Gonzalez	2009/0312728 A1	12/2009	Randolph et al.
8,080,702 B2	12/2011	Blott et al.	2010/0069829 A1	3/2010	Hutchinson et al.
RE43,195 E	2/2012	Cotton	2010/0069850 A1	3/2010	Fabo
D654,095 S	2/2012	Mattson et al.	2010/0069858 A1	3/2010	Olson
8,152,785 B2	4/2012	Vitaris	2010/0069863 A1	3/2010	Olson
8,158,844 B2	4/2012	McNeil	2010/0069885 A1	3/2010	Stevenson et al.
D659,717 S	5/2012	Mattson et al.	2010/0094234 A1	4/2010	Ramella et al.
D661,188 S	6/2012	Fahy	2010/0106112 A1	4/2010	Vogel
D661,189 S	6/2012	Fahy	2010/0106117 A1	4/2010	Lockwood et al.
D661,190 S	6/2012	Fahy	2010/0121286 A1	5/2010	Locke et al.
8,192,409 B2	6/2012	Hardman et al.	2010/0122417 A1	5/2010	Vrzalik et al.
8,240,470 B2	8/2012	Pidgeon et al.	2010/0125258 A1	5/2010	Coulthard et al.
8,267,908 B2	9/2012	Coulthard	2010/0125259 A1	5/2010	Olson
8,298,200 B2	10/2012	Vess et al.	2010/0160901 A1	6/2010	Hu et al.
8,361,043 B2 *	1/2013	Hu A61F 13/0203 604/319	2010/0191198 A1	7/2010	Heagle
8,372,049 B2	2/2013	Jaeb et al.	2010/0210986 A1	8/2010	Sanders
D679,819 S *	4/2013	Peron D24/189	2010/0228205 A1	9/2010	Hu et al.
D679,820 S *	4/2013	Peron D24/189	2010/0230467 A1	9/2010	Criscuolo et al.
8,409,157 B2	4/2013	Haggstrom et al.	2010/0262090 A1	10/2010	Riesinger
8,444,612 B2	5/2013	Patel et al.	2010/0262091 A1	10/2010	Larsson
8,540,699 B2	9/2013	Miller et al.	2010/0268176 A1	10/2010	Johnson et al.
D692,565 S	10/2013	Lattimore et al.	2010/0268198 A1	10/2010	Buan et al.
8,680,360 B2	3/2014	Greener et al.	2010/0305490 A1	12/2010	Coulthard et al.
D705,428 S *	5/2014	Cheney D24/169	2010/0305526 A1	12/2010	Robinson et al.
D705,429 S *	5/2014	Cheney D24/169	2010/0305549 A1	12/2010	Miller et al.
8,715,256 B2	5/2014	Greener	2010/0324510 A1	12/2010	Anderson et al.
8,764,732 B2	7/2014	Hartwell	2010/0324516 A1	12/2010	Braga et al.
8,791,315 B2	7/2014	Lattimore et al.	2011/0004172 A1	1/2011	Eckstein et al.
8,801,685 B2	8/2014	Armstrong et al.	2011/0028918 A1	2/2011	Hartwell
			2011/0028919 A1	2/2011	Johnnison et al.

2011/0054421	A1	3/2011	Hartwell
2011/0054423	A1	3/2011	Blott et al.
2011/0087179	A2	4/2011	Blott et al.
2011/0092927	A1	4/2011	Wilkes et al.
2011/0106030	A1	5/2011	Scholz
2011/0112492	A1	5/2011	Bharti et al.
2011/0172615	A2	7/2011	Greener
2014/0343520	A1	11/2014	Bennett et al.

FOREIGN PATENT DOCUMENTS

DE	3 539 533	5/1987
DE	20 2005 019 670	4/2006
EP	0 122 085	6/1987
EP	0 418 607	3/1991
EP	0 485 657	5/1992
EP	0 617 938	10/1994
EP	0 619 105	10/1994
EP	0619105 A1	10/1994
EP	0 638 301	2/1995
EP	0 670 705	9/1995
EP	0 762 860	12/1997
EP	0 853 950	7/1998
EP	0 651 983	9/1998
EP	0 875 222	7/2002
EP	1 219 311	7/2004
EP	1 488 816	12/2004
EP	1 440 667	3/2006
EP	1 284 777	4/2006
EP	0 620 720	11/2006
EP	1 923 077	11/2006
EP	1 772 160	4/2007
EP	2 098 257	9/2009
EP	2098257 A1	9/2009
EP	2 111 804	10/2009
EP	2 218 431	8/2010
EP	2 335 749	6/2011
EP	2335749 A1	6/2011
FR	1 163 907	10/1958
GB	1063066	3/1967
GB	2085305	1/1985
GB	2305610	4/1997
GB	2329127	3/1999
GB	2357286	11/2003
GB	2389794	12/2003
GB	2423019	8/2006
GB	4 017 441	10/2010
GB	4 017 442	10/2010
GB	4 017 443	10/2010
GB	4 017 444	10/2010
WO	WO 1990/011795	10/1990
WO	WO 1992/013713	8/1992
WO	WO 1993/000056	1/1993
WO	WO 1996/024316	8/1996
WO	WO 1997/043991	11/1997
WO	WO 1998/038955	9/1998
WO	WO 99/01173 A1	1/1999
WO	WO 1999/01173	1/1999
WO	WO 2000/061206	10/2000
WO	WO 2001/049233	7/2001
WO	WO 01/85248 A1	11/2001
WO	WO 2001/085248	11/2001
WO	WO 2002/005737	1/2002
WO	WO 2002/026180	4/2002
WO	WO 2002/039940	5/2002
WO	WO 2002/041878	5/2002
WO	WO 2002/045761	6/2002
WO	WO 2002/070040	9/2002
WO	WO 2002/091965	11/2002
WO	WO 2003/074100	9/2003
WO	WO 2003/092620	11/2003
WO	WO 2004/018020	3/2004
WO	WO 2006/048246	5/2006
WO	WO 2006/130594	12/2006
WO	WO 2007/030599	3/2007
WO	WO 2007/075379	7/2007
WO	WO 2008/036345	3/2008
WO	WO 2008/039839	4/2008
WO	WO 2008/041926	4/2008

WO	WO 2008/064503	6/2008
WO	WO 2008/104609	9/2008
WO	WO 2008/112304	9/2008
WO	WO 2008/141228	11/2008
WO	WO 2008/141470	11/2008
WO	WO 2009/011856	1/2009
WO	WO 2009/019227	2/2009
WO	WO 2009/019229	2/2009
WO	WO 2009/034322	3/2009
WO	WO 2009/047524	4/2009
WO	WO 2009/062327	5/2009
WO	WO 2009/070905	6/2009
WO	WO 2009/078790	6/2009
WO	WO 2009/103031	8/2009
WO	WO 2009/111657	9/2009
WO	WO 2009/126103	10/2009
WO	WO 2009/126833	10/2009
WO	WO 2009/145703	12/2009
WO	WO 2009/158126	12/2009
WO	WO 2010/033574	3/2010
WO	WO 2010/033574 A1	3/2010
WO	WO 2010/033613	3/2010
WO	WO 2010/035017	4/2010
WO	WO 2010/042240	4/2010
WO	WO 2010/051068	5/2010
WO	WO 2010/051073	5/2010
WO	WO 2010/059849	5/2010
WO	WO 2010/072309	7/2010
WO	WO 2010/072349	7/2010
WO	WO 2010/072395	7/2010
WO	WO 2010/075313	7/2010
WO	WO 2010/083135	7/2010
WO	WO 2010/085270	7/2010
WO	WO 2010/118316	10/2010
WO	WO 2010/147533	12/2010
WO	WO 2010/147533 A1	12/2010
WO	WO 2011/019476	2/2011
WO	WO 2011/019476 A1	2/2011
WO	WO 2011/023275	3/2011
WO	WO 2011/023275 A1	3/2011

OTHER PUBLICATIONS

Thomas, S. et al., "Hydrocolloids: A guide to composition, properties and uses of hydrocolloid dressings and the commercial presentations available," *J. of Wound Care*, vol. 1, No. 2, Jul.-Aug. 1992, pp. 27-30, in 5 pages.

ArjoHuntleigh, WoundAssist® Topical Negative Pressure System, retrieved on Jul. 22, 2011, information posted on the website before the priority date of the present application, in 1 page. URL: <http://www.easytnp.com/Page.asp?PageNumber=14>.

Bagautdinov, N.A., "Variant of External Vacuum Aspiration in the Treatment of Purulent Diseases of Soft Tissues", *Current Problems in Modern Clinical Surgery—Interdepartmental Collection*, edited by V. Ye. Volkov et al. (Chuvash State University, Cheboksary, USSR 1986), pp. 94-96, in 8 pages.

Barker, D. et al., "Vacuum Pack Technique of Temporary Abdominal Closure: A 7-Year Experience with 112 Patients", *Journ. of Trauma: Injury and Critical Care*, Feb. 2000, vol. 48 No. 2, pp. 201-207, in 7 pages.

Brock, W.B. et al., "Temporary closure of open abdominal wounds: the vacuum pack", *The American Surgeon*, Jan. 1995, vol. 61(1), pp. 30-35, abstract, in 6 pages.

Fleischmann, W. et al. "Vacuum Sealing for Treatment of Soft Tissue Injury in Open Fractures," *Emergency Surgery* (1993), vol. 96, pp. 488-492, in 5 pages.

Garner, G. et al., "Vacuum-assisted wound closure provides early fascial reapproximation in trauma patients with open abdomens," *Am. J. of Surgery*, vol. 182 (2001), pp. 630-638, in 9 pages.

Harris, D., "A new technique of skin grafting using Stei-Greffé and a self-adhering foam pad," *Brit. J. of Plastic Surg.*, vol. 34, No. 2, Apr. 1981, pp. 181-185, in 6 pages.

Jeter, K. et al., "Managing Draining Wounds and Fistulae: New and Established Methods", *Chronic Wound Care*, 1990, pp. 240-246, in 7 pages.

Kalypto Medical, NPD 1000 NPWT Pump & Control Module Product Specifications, Oct. 2009, in 2 pages.

Kalypto Medical, NPD 1000™ Negative Pressure Wound Therapy System, Jun. 2011, in 4 pages. Retrieved from http://www.kalyptomedical.com/pdf/50089RevB_Kalypto_NPD_1000_Bro_final.pdf.

KCI Licensing, “V.A.C. Abdominal Dressing System Advanced Management of the Open Abdomen,” 2004, in 6 pages.

KCI, Packaging for V.A.C. Via™ Negative Pressure Wound Therapy System, on sale in the United States before the priority date of the present application.

Navsaria, P.H. et al., “Temporary closure of open abdominal wounds by the modified sandwich-vacuum pack technique”, *British Journal of Surgery*, 2003, vol. 90, pp. 718-722, in 8 pages.

Nicholas, J.M., “Options for Management of the Open Abdomen”, Presentation from Emory University School of Medicine, Invited Speaker American College of Surgeons 32nd Annual Spring Meeting, General Session 12—Presentation and Panel Discussion on The Open Abdomen in General Surgery—How Do You Close the Abdomen When You Can’t—Boston Marriott Copley Place Hotel, Boston, MA Apr. 26, 2004, in 66 pages.

Orgill, D.P. et al., “Guidelines for Treatment of Complex Chest Wounds with Negative Pressure Wound Therapy”, *Wounds, A Compendium of Clinical Research and Practice, Suppl. B*, Dec. 2004, pp. 1-23, in 26 pages.

Schein, M. et al., “The ‘Sandwich Technique’ in the Management of the Open Abdomen,” *British Journal of Surgery*, 1986, vol. 73, May 1986, pp. 369-370, in 2 pages.

Smith, L. et al., “Vacuum Pack Technique of Temporary Abdominal Closure: A Four-Year Experience”, *The American Surgeon*, vol. 63(12), Dec. 1997, pp. 1102-1108, in 7 pages.

Smith & Nephew, Blister Pack Tray for Versajet Hydrosurgery System Handpiece (used for debridement of wounds), on sale in the United States more than one year before the priority date of the present application.

Solovev, V. A., “Treatment and Prevention of Suture Failures after Gastric Resection”, Dissertation Abstract, S.M. Kirov Gorky State Medical Institute, USSR, 1988, in 51 pages.

Web page labeled “The XVS System,” printed from Cerulean Medical website, available before Oct. 14, 2010, in 1 page. URL: http://ceruleanmedical.com/Cerulean_Medical/The_XVS_System.html.

Allevyn Educational Booklet, Smith & Nephew Medical Ltd, Apr. 2014.

Allevyn Wound Dressings Pamphlet, Smith & Nephew, Inc., 2008. KCI Licensing, Prevena™ Incision Management System, Jan. 2010, in 2 pages.

KCI, Prevena™ Incision Management System Clinician Guide, Jan. 2010.

KCI Licensing, Prevena™ Incision Management System Patient Guide, Jan. 2010, in 4 pages.

Teder, H. et al., “Continuous Wound Irrigation in the Pig,” *Journal of Investigative Surgery*, vol. 3, 1990, pp. 399-407, in 9 pages.

US. Appl. No. 29/389,782, filed Apr. 15, 2011, Peron.

U.S. Appl. No. 13/092,042, filed Apr. 21, 2011.

* cited by examiner

Primary Examiner — Darlington Ly

(74) *Attorney, Agent, or Firm* — Knobbe, Martens, Olson & Bear, LLP

(57)

CLAIM

The ornamental design for a medical dressing, as shown and described.

DESCRIPTION

The present application is a continuation reissue application of U.S. Reissue application Ser. No. 29/639,290, which is a continuation reissue application of U.S. Reissue application Ser. No. 29/548,270, which is a divisional reissue application of U.S. Reissue application Ser. No. 29/510,717, filed Dec. 2, 2014, which is an application for reissue of U.S. Des. Pat. No. 679,820, filed Apr. 15, 2011, which claims priority to United Kingdom Design Registration No. 4017442, filed Oct. 15, 2010, and United Kingdom Design Registration No. 4017443, filed Oct. 15, 2010.

[FIG. 1 is a perspective top view of one embodiment of a medical dressing.]

[FIG. 2 is another perspective top view of the medical dressing of FIG. 1.]

[FIG. 3 is a top plan view of the medical dressing of FIG. 1.]

[FIG. 4 is a bottom view of the medical dressing of FIG. 1.]

[FIG. 5 is a far side view of the medical dressing of FIG. 1.]

[FIG. 6 is near side view of the medical dressing of FIG. 1.]

[FIG. 7 is a front view of the medical dressing of FIG. 1; and.]

[FIG. 8 is a rear view of the medical dressing of FIG. 1.]

FIG. 9 is a top, right-side, and front perspective view of a medical dressing.

FIG. 10 is a top, right-side, and rear perspective top view of the medical dressing of FIG. 9.

FIG. 11 is a top plan view of the medical dressing of FIG. 9.

FIG. 12 is a bottom plan view of the medical dressing of FIG. 9.

FIG. 13 is a left side elevation view of the medical dressing of FIG. 9.

FIG. 14 is a right side elevation view of the medical dressing of FIG. 9.

FIG. 15 is a front elevation view of the medical dressing of FIG. 9; and,

FIG. 16 is a rear elevation view of the medical dressing of FIG. 9.

The broken lines in the drawings illustrate portions of the medical dressing that form no part of the claimed design.

1 Claim, 16 Drawing Sheets

Matter enclosed in heavy brackets [] appears in the original patent but forms no part of this reissue; matter printed in italics indicates the additions made by reissue.

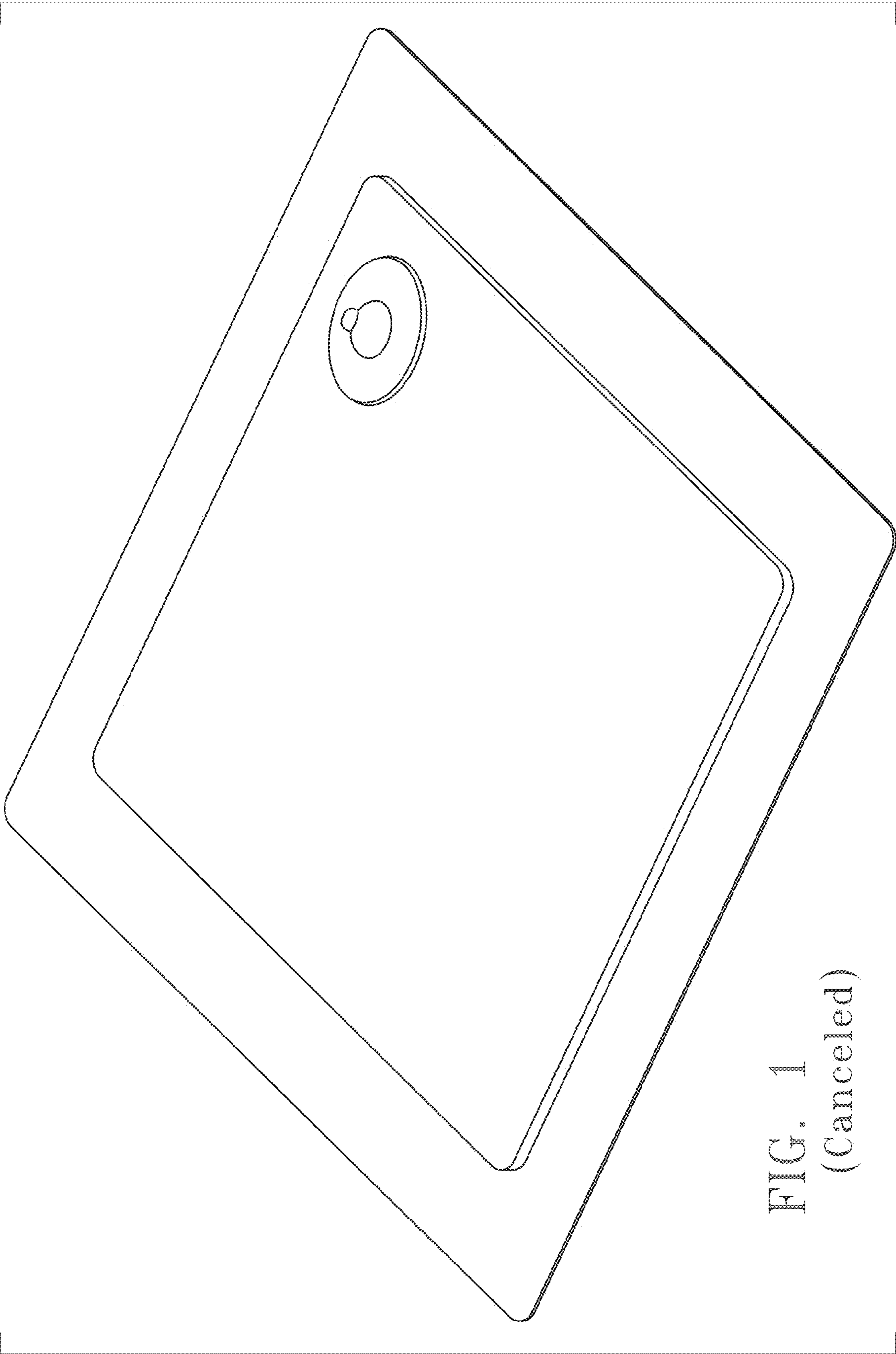

FIG. 1
(Canceled)

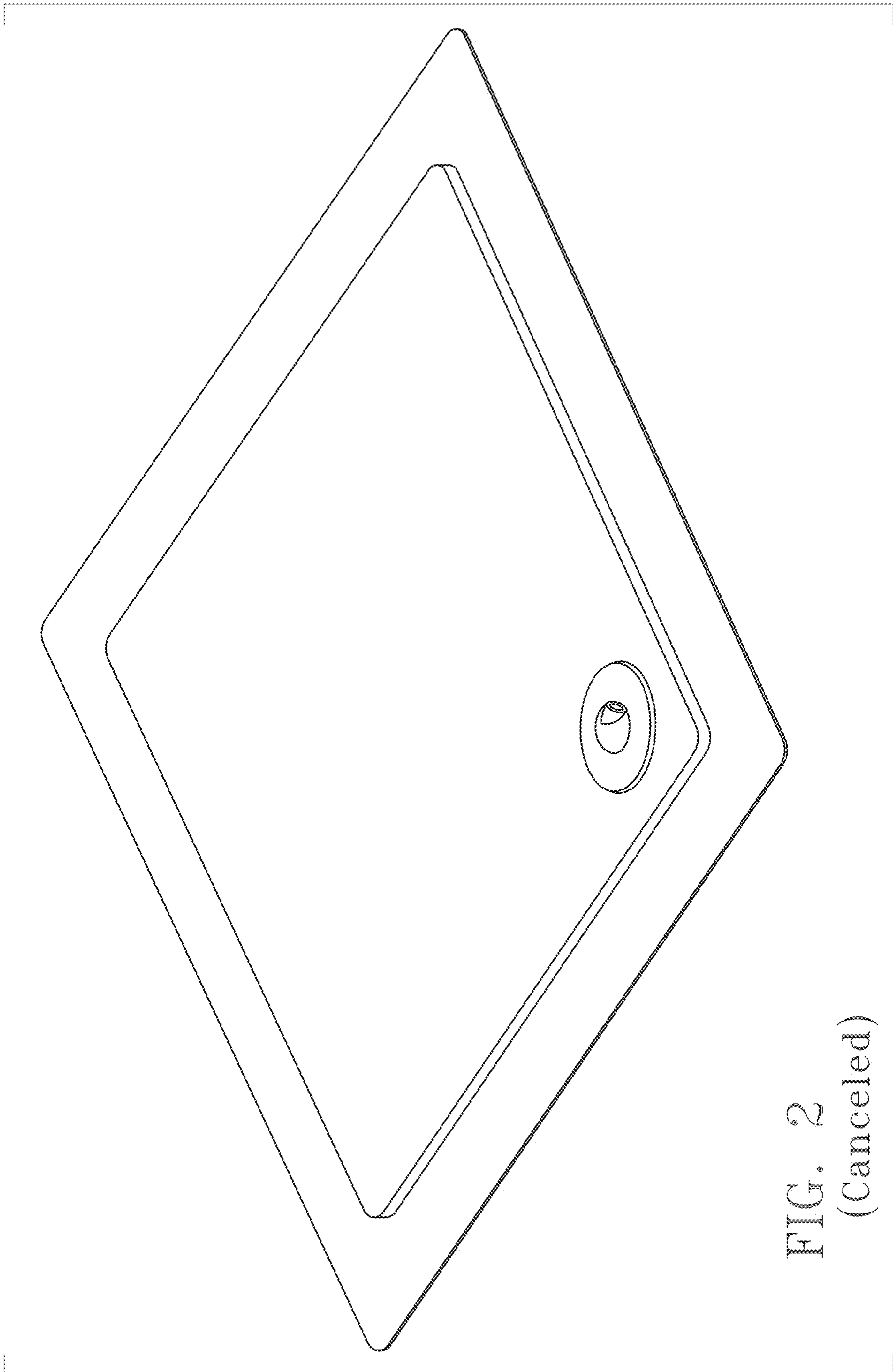

FIG. 2
(Canceled)

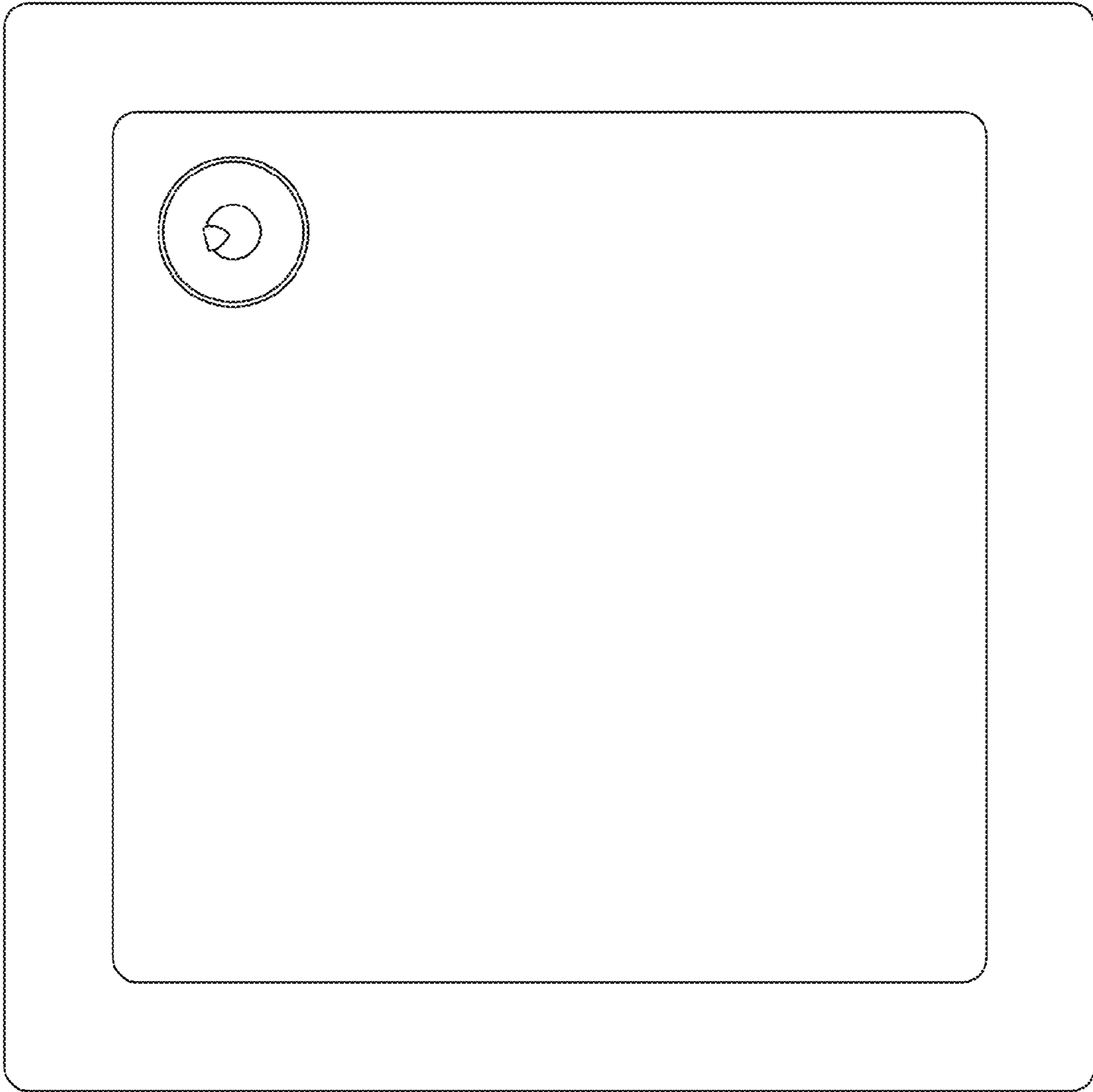

FIG. 3
(Canceled)

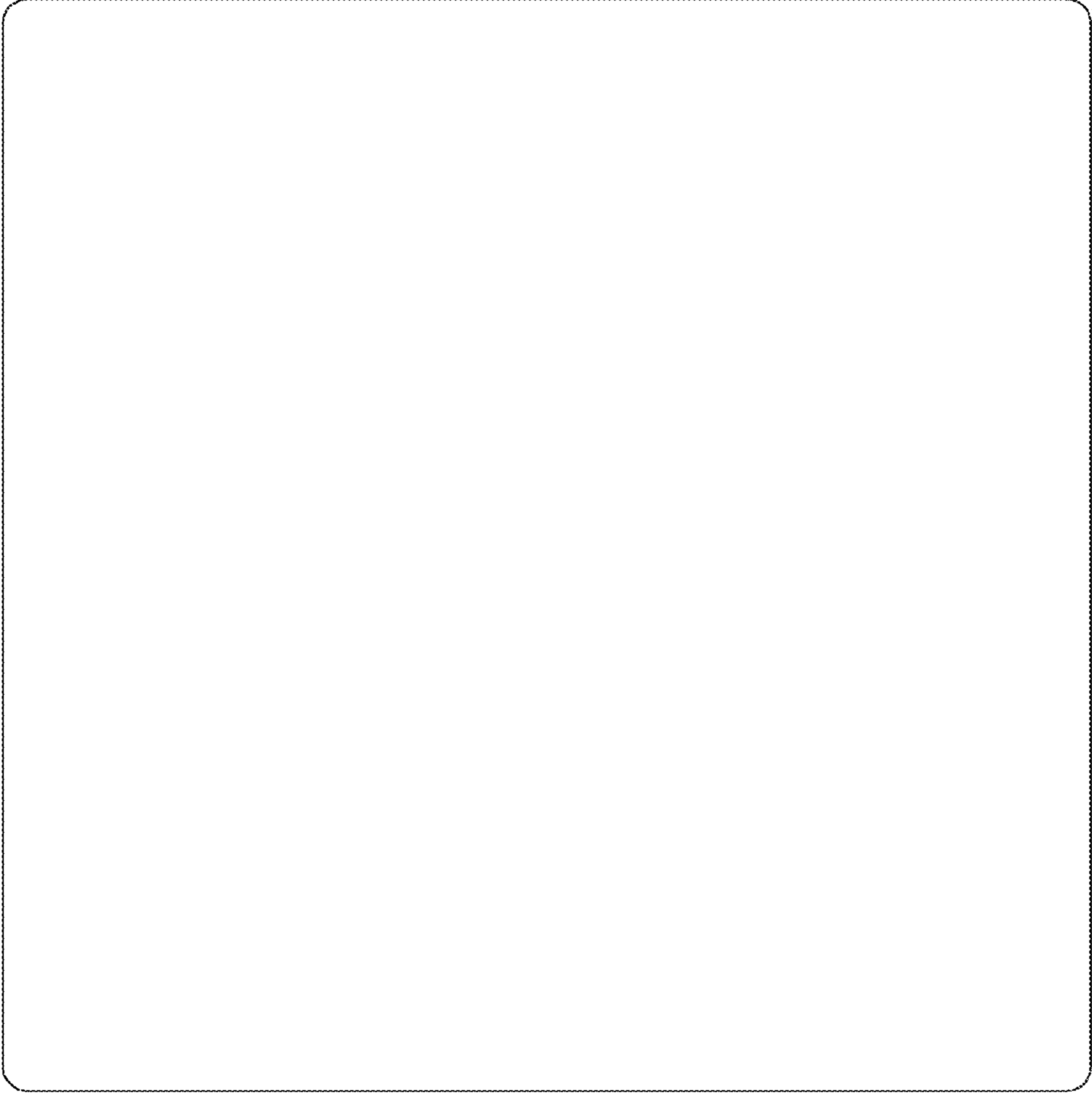
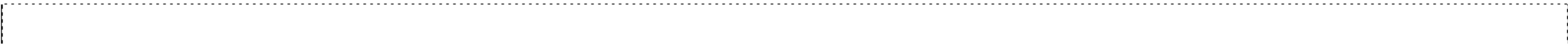

FIG. 4
(Canceled)



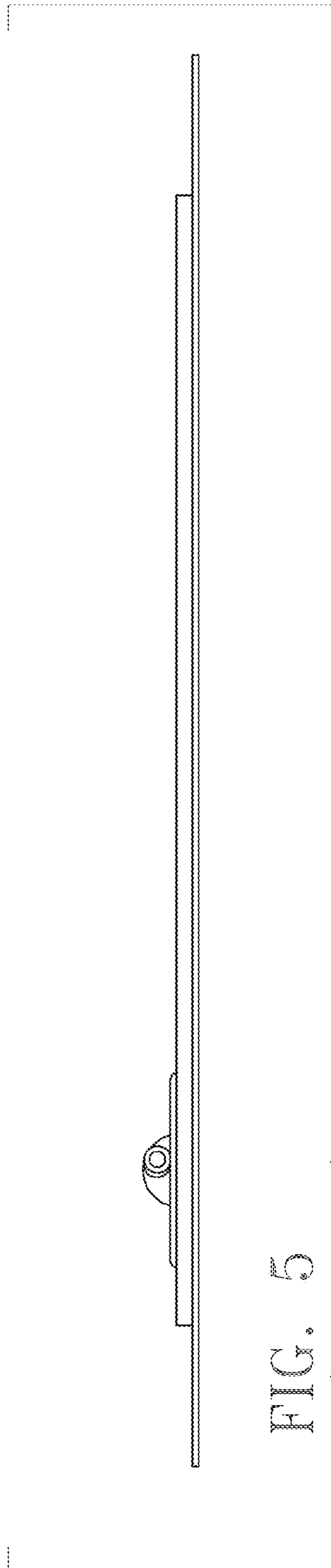

FIG. 5
(Canceled)

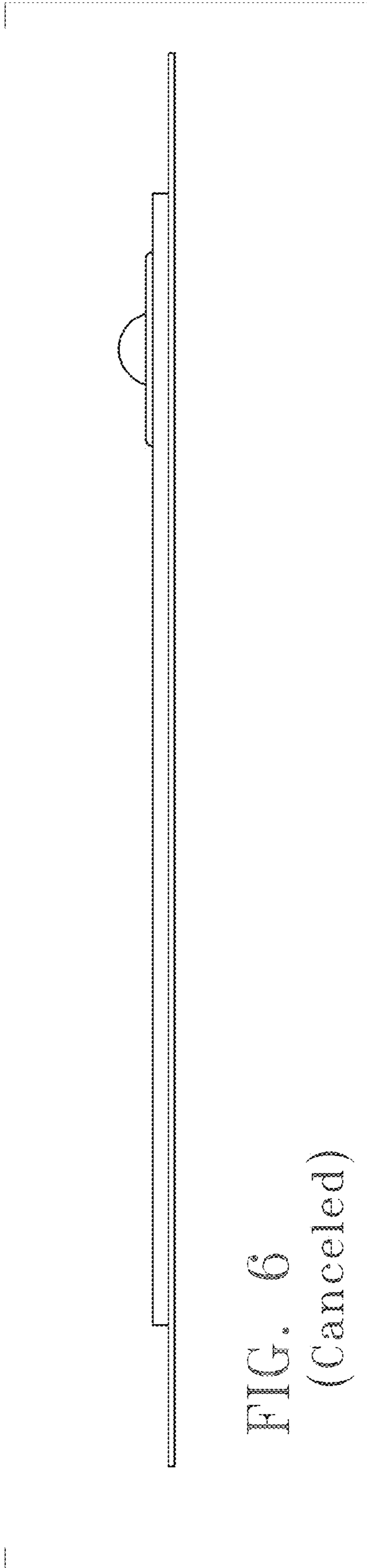

FIG. 6
(Canceled)

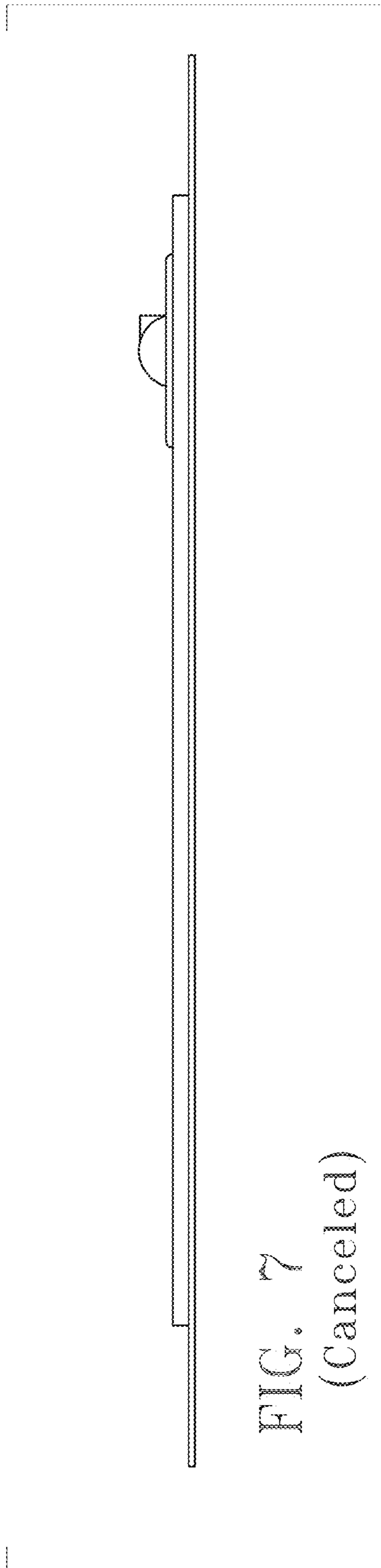

FIG. 7
(Canceled)

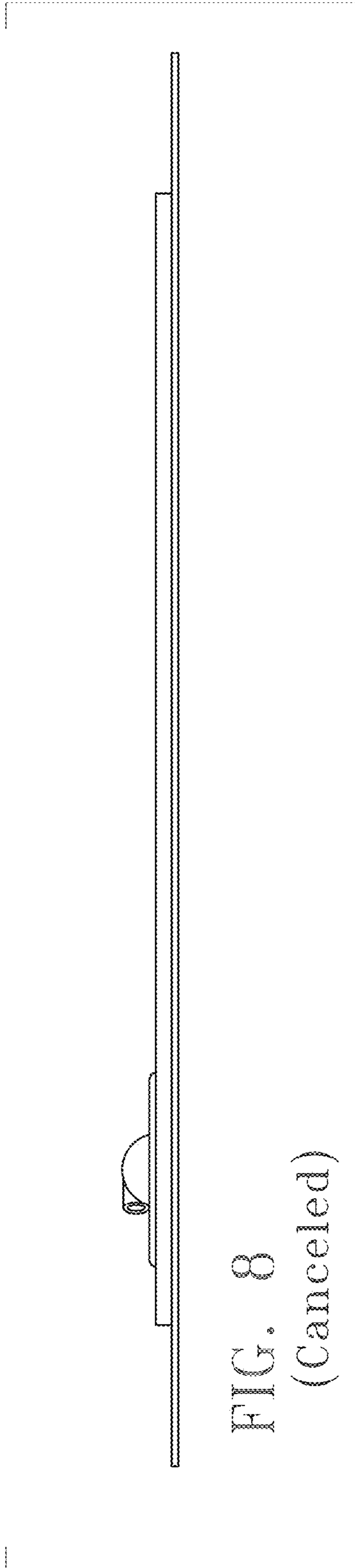

FIG. 8
(Canceled)

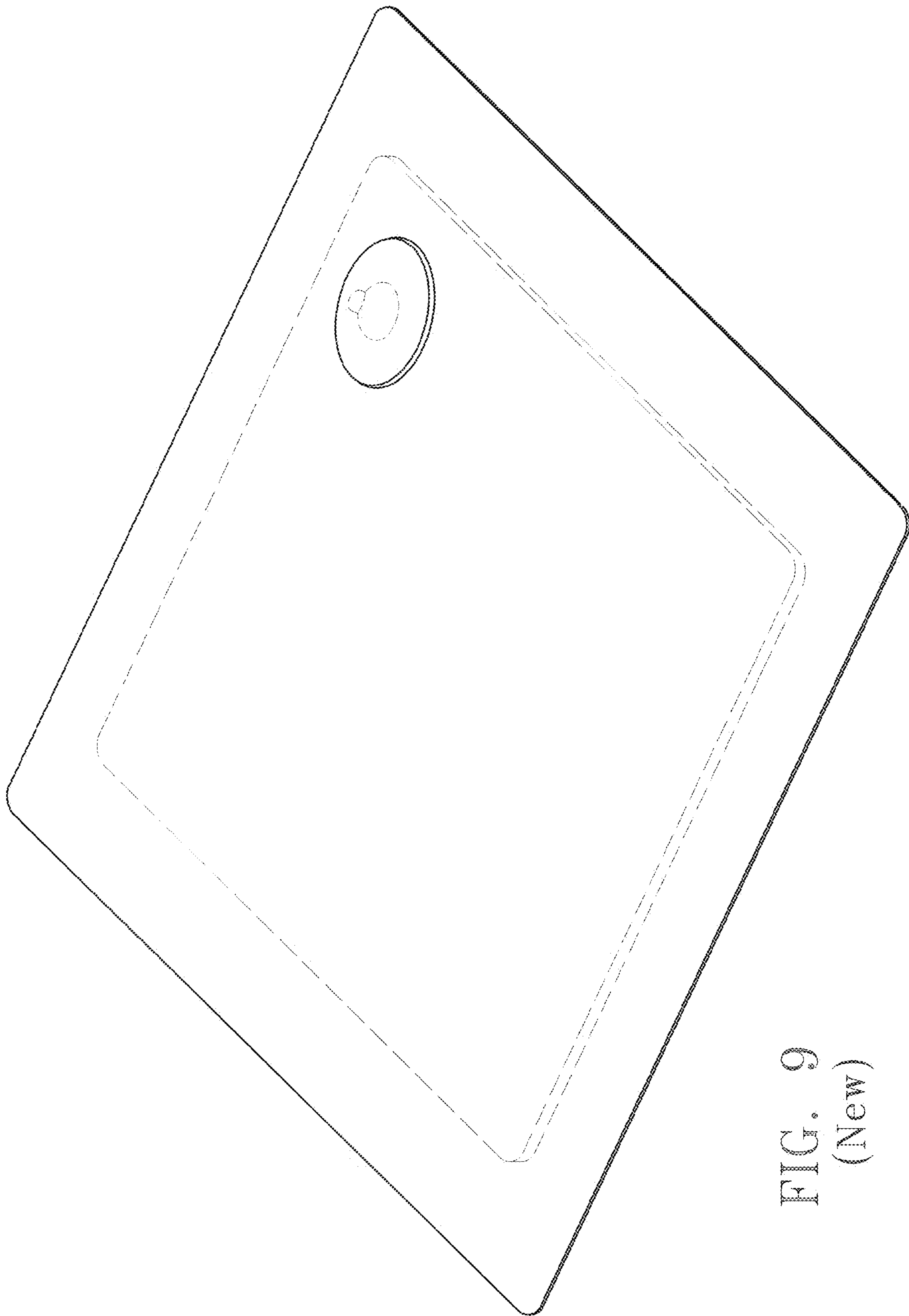

FIG. 9
(New)

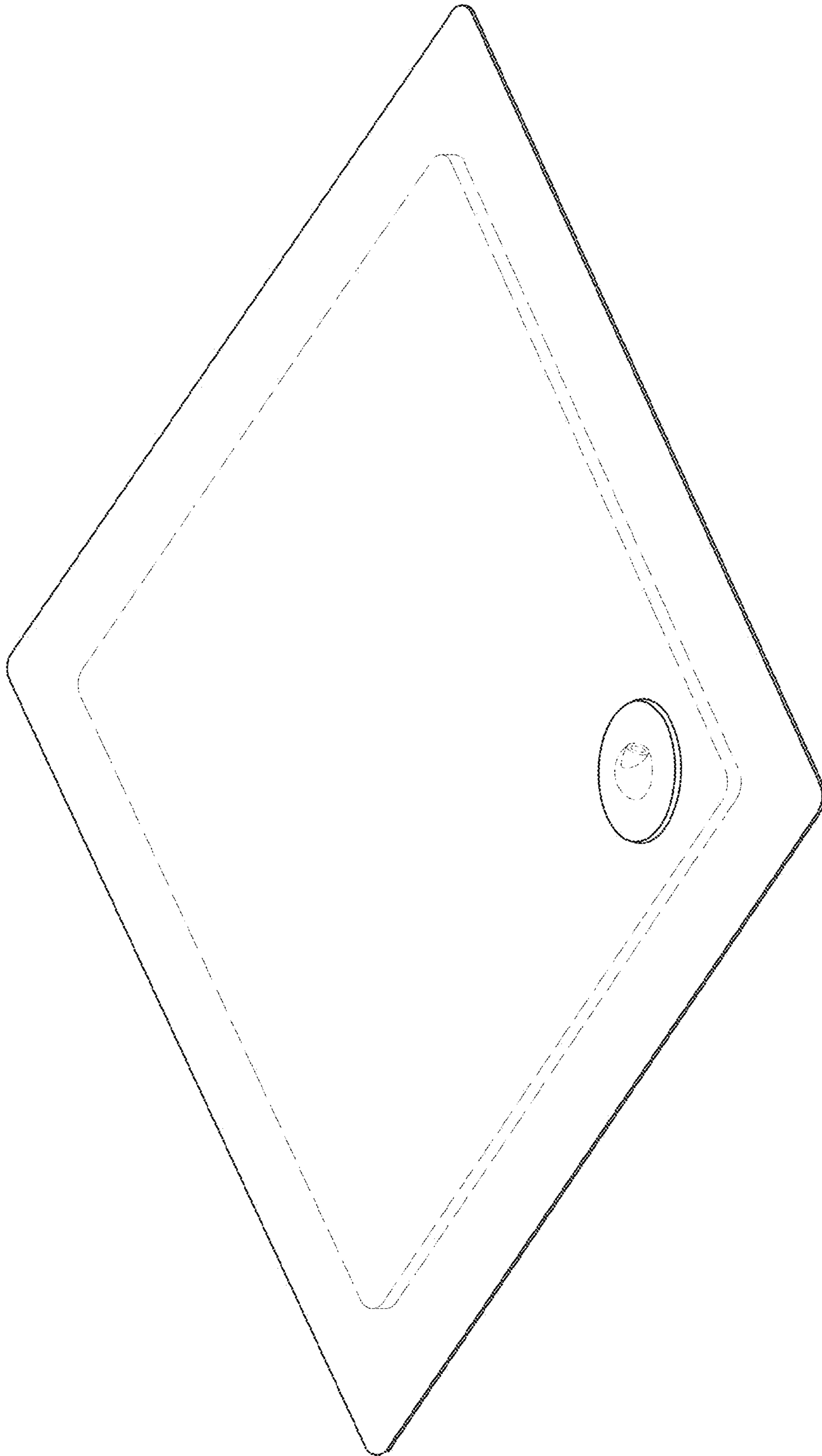

FIG. 10
(New)

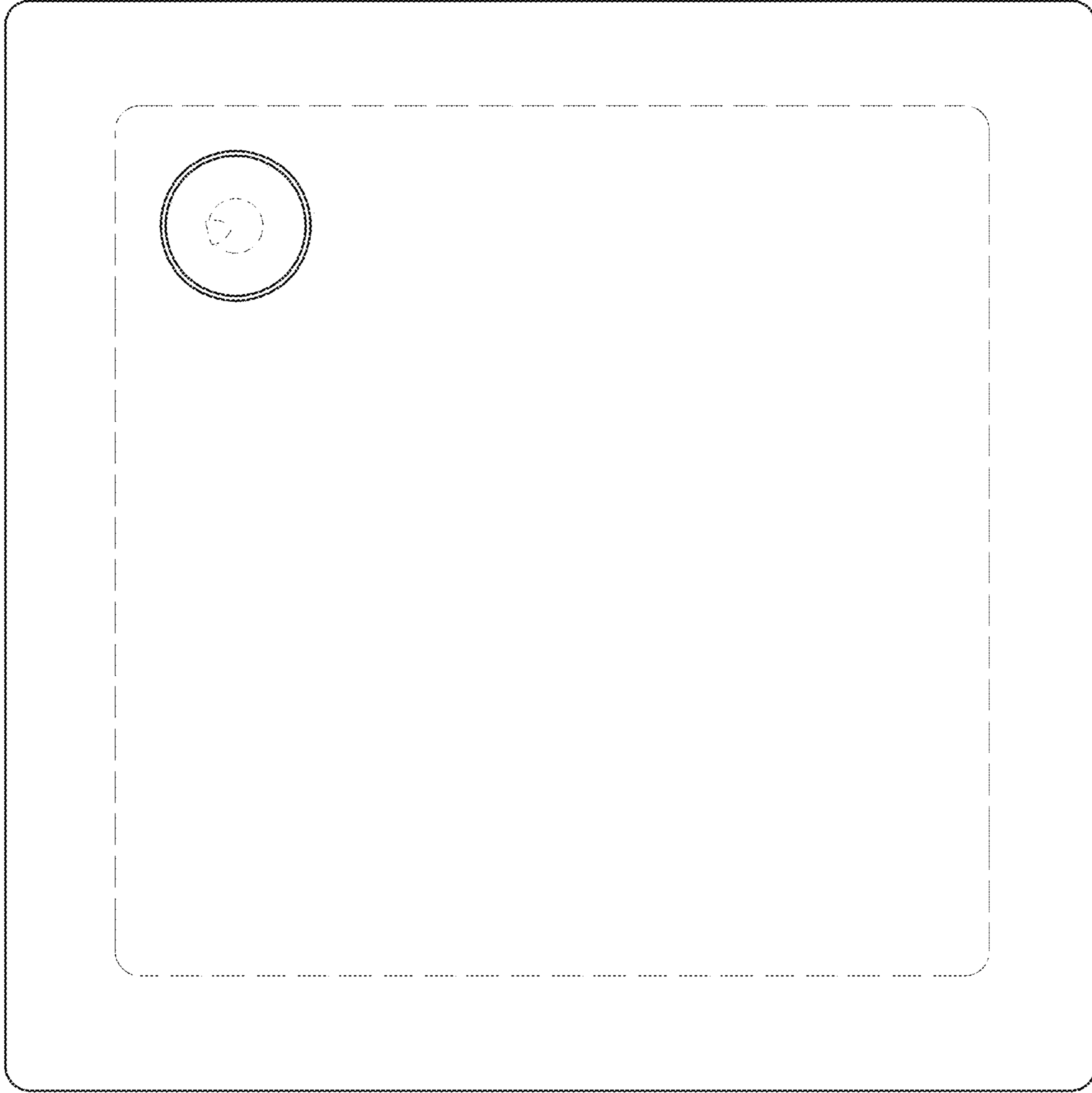

FIG. 11
(New)

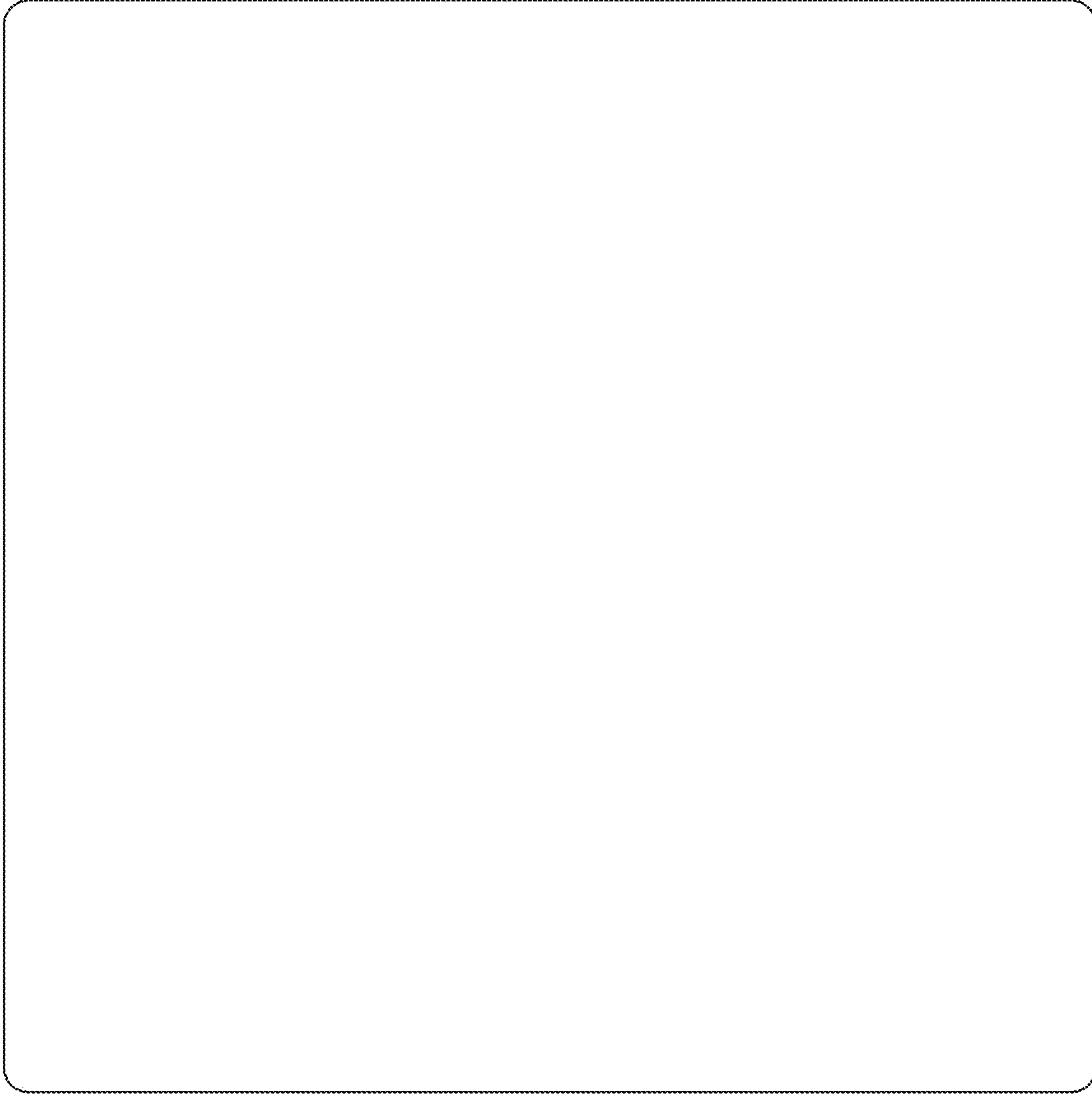

FIG. 12
(New)

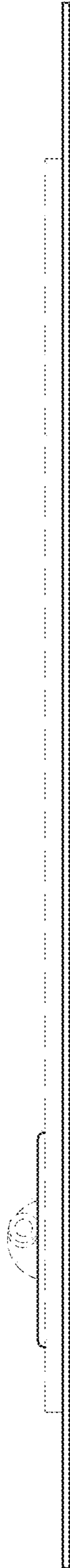

FIG. 13
(New)



FIG. 14
(New)

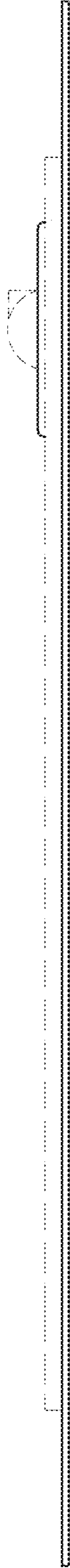

FIG. 15
(New)

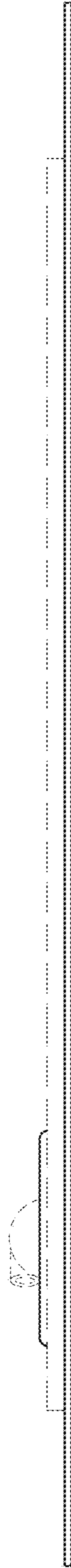

FIG. 16
(New)

UNITED STATES PATENT AND TRADEMARK OFFICE
CERTIFICATE OF CORRECTION

PATENT NO. : RE49,227 E
APPLICATION NO. : 29/709413
DATED : October 4, 2022
INVENTOR(S) : Yannick Louis Peron

Page 1 of 1

It is certified that error appears in the above-identified patent and that said Letters Patent is hereby corrected as shown below:

On the Title Page

Column 1, Item (22) (Filed), delete "Mar. 19, 2020" and insert -- Oct. 14, 2019 --.

Signed and Sealed this
Eighteenth Day of July, 2023
Katherine Kelly Vidal

Katherine Kelly Vidal
Director of the United States Patent and Trademark Office