



US00RE49104E

(19) **United States**
(12) **Reissued Patent**
Fitzpatrick et al.

(10) **Patent Number: US RE49,104 E**
(45) **Date of Reissued Patent: *Jun. 14, 2022**

(54) **AMMUNITION MAGAZINE**

(71) Applicant: **Magpul Industries Corp.**, Austin, CO (US)

(72) Inventors: **Richard M. Fitzpatrick**, West Lake Hills, TX (US); **Michael T. Mayberry**, Denver, CO (US); **Brian L. Nakayama**, Arvada, CO (US); **Eric C. Burt**, Broomfield, CO (US)

(73) Assignee: **Magpul Industries Corp.**, Austin, TX (US)

(*) Notice: This patent is subject to a terminal disclaimer.

(21) Appl. No.: **17/017,408**

(22) Filed: **Sep. 10, 2020**

Related U.S. Patent Documents

Reissue of:

(64) Patent No.: **10,072,903**
Issued: **Sep. 11, 2018**
Appl. No.: **15/661,620**
Filed: **Jul. 27, 2017**

U.S. Applications:

(63) Continuation of application No. 14/632,804, filed on Feb. 26, 2015, now Pat. No. 9,746,264, which is a (Continued)

(51) **Int. Cl.**
F41A 9/65 (2006.01)
F41A 9/70 (2006.01)
(Continued)

(52) **U.S. Cl.**
CPC **F41A 9/70** (2013.01); **F41A 9/62** (2013.01); **F41A 9/65** (2013.01); **F41A 9/67** (2013.01); **F41A 9/69** (2013.01); **F41A 9/83** (2013.01)

(58) **Field of Classification Search**
CPC **F41A 9/62**; **F41A 9/70**; **F41A 9/69**; **F41A 9/65**; **F41A 9/83**; **F41A 9/67**
See application file for complete search history.

(56) **References Cited**

U.S. PATENT DOCUMENTS

1,323,063 A 11/1919 Johnson et al.
3,395,479 A * 8/1968 Collins F41A 9/70
42/50

(Continued)

FOREIGN PATENT DOCUMENTS

DE 654386 C 12/1937
DE 1094155 B 12/1960

(Continued)

OTHER PUBLICATIONS

“Claims Chart Re U.S. Pat. No. 5,638,626 (Westrom)”, “Prior Art Exhibit J in Civil Action No. 1:13-cv-01983-RBJ, *Magpul Industries Corp v. Brookshire Tool & MFG Company, Inc. dba PROMAG Industries*”, p. 21, Published in: US.

(Continued)

Primary Examiner — Jeffrey R Jastrzab

(74) *Attorney, Agent, or Firm* — Neugeboren O’Dowd PC

(57) **ABSTRACT**

The present invention is an ammunition magazine, preferably made of a reinforced polymer, utilizing a structurally enhancing ridge, angular guide rails and a follower made to interface with said guide rails to reduce wobble. The preferred embodiment also features a protective cover that distributes forces from the spring to more structurally sound areas of the magazine, thus reducing feed end splay, and an ammunition indication system comprised of at least one window and a noticeable marker on the follower spring. The follower and magazine casing are also designed to interface to prevent the follower from popping out of the feed end and the floor plate of the magazine utilizes a locking plate and sliding relationship between the floor plate, locking plate and magazine to secure the floor plate onto the magazine casing. The cover features built in tools for, among other things, unloading and disassembling the magazine.

16 Claims, 16 Drawing Sheets

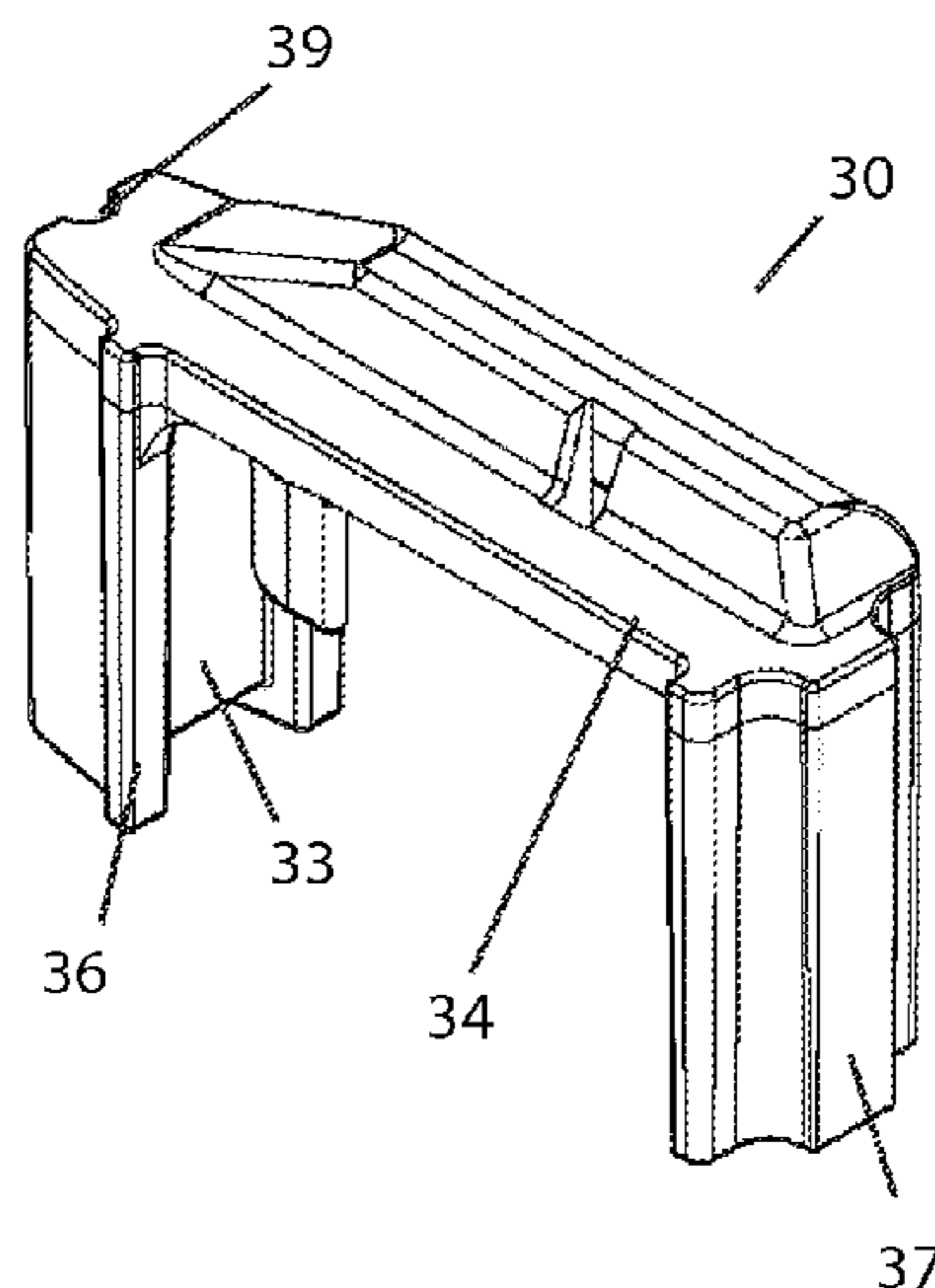

Related U.S. Application Data

continuation of application No. 14/461,229, filed on Aug. 15, 2014, now Pat. No. 8,991,086, which is a continuation-in-part of application No. 14/098,467, filed on Dec. 5, 2013, now Pat. No. 8,839,543, which is a continuation of application No. 13/307,431, filed on Nov. 30, 2011, now Pat. No. 8,635,796.

(51) **Int. Cl.**

- F41A 9/62* (2006.01)
- F41A 9/67* (2006.01)
- F41A 9/69* (2006.01)
- F41A 9/83* (2006.01)

(56)

References Cited

U.S. PATENT DOCUMENTS

3,443,334	A	5/1969	Ardonlino	
3,453,762	A	7/1969	Fremont	
4,127,954	A	12/1978	Hausmann	
4,408,409	A	10/1983	Arias	
4,589,218	A	5/1986	Teppa	
4,672,760	A	6/1987	Chesnut et al.	
5,113,605	A	5/1992	Kim	
5,149,897	A	9/1992	Howard	
5,309,660	A	5/1994	Blackamore	
5,345,660	A	9/1994	Howard	
5,956,878	A	9/1999	Yang	
7,093,386	B1	8/2006	Vieweg	
7,533,483	B1	5/2009	Alazmora et al.	
7,908,780	B2	3/2011	Fitzpatrick et al.	
8,069,601	B1	12/2011	Fitzpatrick et al.	
8,225,541	B2	7/2012	Bigley et al.	
8,635,796	B2	1/2014	Fitzpatrick et al.	
8,839,543	B2	9/2014	Fitzpatrick et al.	
8,991,086	B2	3/2015	Fitzpatrick et al.	
9,746,264	B2	8/2017	Fitzpatrick et al.	
10,072,903	B2	9/2018	Fitzpatrick et al.	
2003/0066227	A1	4/2003	Fitzpatrick	
2010/0101132	A1	4/2010	Jacobson	
2011/0005113	A1	1/2011	Fitzpatrick et al.	
2011/0113663	A1*	5/2011	Nakayama F41A 9/70 42/50
2014/0215878	A1	8/2014	Fitzpatrick et al.	
2015/0184983	A1	7/2015	Pink et al.	

FOREIGN PATENT DOCUMENTS

EP	0608072	A1 *	7/1994 F41A 17/38
EP	2208957	A2 *	7/2010 F41A 9/70
GB	275606	A	10/1927	

OTHER PUBLICATIONS

Magpul, "Magpul PMAG Versus a Chevy Truck", "Retrieved from <https://www.youtube.com/watch?v=UCFXcOOB4jc>", Feb. 24, 2007, p. 3, Published in: US.

Johnson, Stephen, "Office Action Regarding U.S. Appl. No. 16/100,460", dated Oct. 19, 2018, p. 29, Published in: US.

Gruber, Stephen, "Response to office action regarding U.S. Appl. No. 16/100,460", dated Mar. 14, 2019, p. 13, Published in: US.

Nash, William B., "Magpul Industries Corp., V. Brookshire Tool and MFG. Company, Inc. DBA Promag Industries Civil Action No. 1:13-CV-01983-", "First Amended Answer, Affirmative Defenses and Counterclaims", Feb. 18, 2014, p. 19, Published in: US.

Nash, William B., "Civil Action No. 1:13-CV-01983-RBJ; Magpul Industries Corp. V. Brookshire Tool and MFG Company, Inc. DBA Promag Industries", "Second Amended Answer, Affirmative Defenses, and Counterclaims", Mar. 11, 2014, p. 19, Published in: US.

"Claims Chart Re U.S. Pat. No. 7,533,483 (Alzamora)", "Prior Art Exhibit A in Civil Action No. 1:13-cv-01983-RBJ, *Magpul Industries Corp v. Brookshire Tool & MFG Company, Inc*", p. 34, Published in: US.

"Claims Chart Re U.S. Pat. No. 3,377,732 (Bivens)", "Prior Art Exhibit K in Civil Action No. 1:13-cv-01983-RBJ, *Magpul Industries Corp v. Brookshire Tool & MFG Company, Inc. dba Promag Industries*", p. 26, Published in: US.

"Claims Chart Re U.S. Pat. No. 7,497,044 (Cammenga)", "Prior Art Exhibit F in Civil Action No. 1:13-cv-01983-RBJ, *Magpul Industries Corp v. Brookshire Tool & MFG Company, Inc. dba Promag Industries*", p. 22, Published in: US.

"Claims Chart Re U.S. Pat. No. 3,906,652 (Evans)", "Prior Art Exhibit L in Civil Action No. 1:13-cv-01983-RBJ, *Magpul Industries Corp v. Brookshire Tool & MFG Company, Inc. dba Promag Industries*", p. 17, Published in: US.

"Claims Chart Re U.S. Pat. No. 3,465,463 (Grandy)", "Prior Art Exhibit H in Civil Action No. 1:13-cv-01983-RBJ, *Magpul Industries Corp v. Brookshire Tool & MFG Company, Inc. dba Promag Industries*", p. 18, Published in: US.

Gruber, Stephen, "Response to Office Action Regarding U.S. Appl. No. 15/661,620", dated Mar. 30, 2018, p. 11, Published in: US.

"Claims Chart Re U.S. Pat. No. 2,081,235 (Hillyard)", "Prior Art Exhibit E in Civil Action No. 1:13-cv-01983-RBJ, *Magpul Industries Corp v. Brookshire Tool & MFG Company, Inc. dba Promag Industries*", p. 21, Published in: US.

Johnson, Stephen, "United States Office Action Re U.S. Appl. No. 15/661,620", dated Nov. 2, 2017, p. 54, Published in: US.

"Claims Chart Re U.S. Pat. No. 2,783,570 (Kunz)", "Prior Art Exhibit G in Civil Action No. 1:13-cv-01983-RBJ, *Magpul Industries Corp v. Brookshire Tool & MFG Company, Inc. dba Promag Industries*", p. 15, Published in: US.

Tactical Testing & Evaluation, LLC, "Magpul PMAG", "Downloaded from <http://ttelc.net/pmag.htm>", Oct. 14, 2007, p. 2, Published in: US.

"Claims Chart Re U.S. Pat. No. 3,73,686 (Moller)", "Prior Art Exhibit C in Civil Action No. 1:13-cv-01983-RBJ, *Magpul Industries Corp v. Brookshire Tool & MFG Company, Inc. dba Promag Industries*", p. 24, Published in: US.

"Claims Chart Re U.S. Pat. No. 3,110,122 (Musgrave)", "Prior Art Exhibit I in Civil Action No. 1:13-cv-01983-RBJ, *Magpul Industries Corp v. Brookshire Tool & MFG Company, Inc. dba Promag Industries*", p. 20, Published in: US.

"Claims Chart Re U.S. Pat. No. 3,226,869 (Musgrave)", "Prior Art Exhibit D in Civil Action No. 1:13-cv-01983-RBJ, *Magpul Industries Corp v. Brookshire Tool & MFG Company, Inc. dba Promag Industries*", p. 22, Published in: US.

Magpul Industries, Corp., "http://www.magpul.com/catalog/images/pmag1_02.jpg", "Printed Publications on www.magpul.com", Jul. 16, 2007, p. 2, Publisher: Magpul Industries Corp, Published in: US.

Magpul Industries, Corp., "http://www.magpul.com/catalog/images/pmag1_03.jpg", "Printed Publications on www.magpul.com", Dec. 2, 2007, p. 2, Publisher: Magpul Industries Corp., Published in: US.

Magpul Industries, Corp., "http://www.magpul.com/catalog/images/pmag1_04.jpg", "Printed Publications on www.magpul.com", Dec. 2, 2007, p. 2, Publisher: Magpul Industries Corp., Published in: US.

Magpul Industries, Corp., "http://www.magpul.com/catalog/images/pmag1_05.jpg", "Printed Publication on www.magpul.com", Jul. 16, 2007, p. 2, Publisher: Magpul Industries Corp., Published in: US.

Magpul Industries, Corp., "http://www.magpul.com/catalog/images/pmag1_06.jpg", "Printed Publications on www.magpul.com", Jul. 16, 2007, p. 2, Publisher: Magpul Industries Corp, Published in: US.

Magpul Industries, Corp., "The sale and/or offer for sale of the Magpul PMAG", Apr. 28, 2007, p. 6, Published in: US.

"Claims Chart Re U.S. Pat. No. 4,589,218 (Teppa)", "Prior Art Exhibit B in Civil Action No. 1:13-cv-01983-RBJ, *Magpul Industries Corp v. Brookshire Tool & MFG Company, Inc. dba PROMAG Industries*", p. 28, Published in: US.

Johnson, Stephen, "United States Office Action Re U.S. Appl. No. 14/632,804", dated Feb. 2, 2017, p. 8, Published in: US.

Johnson, Stephen, "United States Office Action Re U.S. Appl. No. 14/632,804", dated Apr. 15, 2016, p. 35, Published in: US.

(56)

References Cited

OTHER PUBLICATIONS

- Johnson, Stephen, "United States Office Action Re U.S. Appl. No. 14/632,804", dated Aug. 8, 2016, p. 10, Published in: US.
- Gruber, Stephen S., "Response to Office Action Re U.S. Appl. No. 14/632,804", dated Jan. 9, 2016, p. 11, Published in: US.
- Gruber, Stephen S., "Response to Office Action Re U.S. Appl. No. 14/632,804", dated May 1, 2017, p. 8, Published in: US.
- Gruber, Stephen S., "Response to Office Action Re U.S. Appl. No. 14/632,804", dated Jun. 15, 2016, p. 16, Published in: US.
- Nash, William B., "*MAGPUL Industries Corp., v. Brookshire Tool and MFG. Company, Inc. dba PROMAG Industries* Civil Action No. 1:13-cv-01983-", "First Amended Answer, Affirmative Defenses . . .", Feb. 18, 2014, p. 19, Published in: US.
- Nash, William B., "Civil Action No. 1:13-cv-01983-RBJ; *Magpul Industries Corp. v. Brookshire Tool and MFG Company, Inc. dba Promag Indsutri*", Mar. 11, 2014, p. 19, Published in: US.
- "Alzamora Chart re U.S. Pat. No. 7,533,483", "Exhibit A", p. 34, Published in: US.
- Adams, W. Thad, "Re: *Magpul Industries Corp. v. Big Rock Sports, LLC; Magpul Industries Corp. v. Plinker Arms, LLC*", Sep. 9, 2013, p. 8, Published in: US.
- "Bivens Chart re U.S. Pat. No. 3,377,732", p. 26, Published in: US.
- "Cammenga Chart re U.S. Pat. No. 7,497,044", "Exhibit F", p. 22, Published in: US.
- Long, Alexander S., "Report of the conduct of Geoffrey E. Dobbin pursuant to 37 C.F.R. 11.803", Dec. 13, 2013, p. 8, Published in: US.
- "Document Production for Civil Action *Magpul Industries Corp. v. Brookshire Tool & MFG Company, Inc. dba Promag Industries*", p. 92, Published in: US.
- "Evans Chart re U.S. Pat. No. 3,906,652", p. 17, Published in: US.
- "Grandy Chart re U.S. Pat. No. 3,465,463", p. 18, Published in: US.
- "Hillyard Chart re U.S. Pat. No. 2,081,235", p. 21, Published in: US.
- Adam Webber—hkparts.net, "Product page for G36 30 Round Mag", Oct. 9, 2013, p. 2, Publisher: Page downloaded from www.hkparts.net/shop/pc/G36-30-Round-Mag-13p624.htm downloaded on, Published in: US.
- "Kunz Chart re U.S. Pat. No. 2,783,570", p. 15, Published in: US.
- "Moller Chart re U.S. Pat. No. 3,736,686", p. 24, Published in: US.
- "Musgrave Chart re U.S. Pat. No. 3,110,122", p. 20, Published in: US.
- "Musgrave Chart re U.S. Pat. No. 3,226,869", p. 22, Published in: US.
- Johnson, Stephen, "Office Action re U.S. Appl. No. 14/098,467", dated Mar. 21, 2014, p. 42, Published in: US.
- Johnson, Stephen, "Office Action re U.S. Appl. No. 13/307,431", dated Apr. 5, 2013, p. 7, Published in: US.
- Johnson, Stephen, "Office Action re U.S. Appl. No. 14/098,467", dated Apr. 8, 2014, p. 5, Published in: US.
- Johnson, Stephen, "Office Action re U.S. Appl. No. 14/461,229", dated Oct. 9, 2014, p. 27, Published in: US.
- Johnson, Stephen, "Office Action re U.S. Appl. No. 13/307,431", dated Nov. 2, 2012, p. 8, Published in: US.
- Johnson, Stephen, "Office Action re U.S. Appl. No. 13/307,431", dated Nov. 22, 2013, p. 21, Published in: US.
- Magpul Industries, Corp., "Printed Publications on www.magpul.com", Jul. 16, 2007, p. 2, Retrieved from http://www.magpul.com/catalog/images/pmag1_02.jpg. Published in: US.
- Magpul Industries, Corp., "Printed Publications on www.magpul.com", Dec. 2, 2007, p. 2, Retrieved form http://www.magpul.com/catalog/images/pmag1_03.jpg. Published in: US.
- Magpul Industries, Corp., "Printed Publications on www.magpul.com", Dec. 2, 2007, p. 2, Retrieved from http://www.magpul.com/catalog/images/pmag1_04.jpg. Published in: US.
- Magpul Industries, Corp., "Printed Publication on www.magpul.com", Jul. 16, 2007, p. 2, Retrieved from http://www.magpul.com/catalog/images/pmg1_05.jpg. Published in: US.
- Magpul Industries, Corp., "Printed Publications on www.magpul.com", Jul. 16, 2007, p. 2, Retrieved from http://www.magpul.com/catalog/images/pmag1_06.jpg. Published in: US.
- Magpul Industries, Corp. "Magpul PMag versus a Chevy Truck." Feb. 24, 2007. Retrieved from <https://www.youtube.com/watch?v=UCFXcOOB4jc>.
- Nash, William B., "ProMag's Invalidity Contentions", "Civil Action No. 1:13-cv-01983-RBJ, *Magpul Industries Corp v. Brookshire Tool & MFG Company, Inc. dba PROMAG Industries*", Apr. 28, 2014, p. 11, Published in: US.
- Nash, William B., "PROMAG's Invalidity Contentions for U.S. Pat. No. D614,719S", "Civil Action No. 1:13-cv-01983-RBJ- *MAGPUL Industries Corp., v. Brookshire Tool and MFG Company, Inc. dba PROMAG Industries*", May 12, 2014, p. 9, Published in: US.
- Gruber, Stephen S., "Response to Office Action re U.S. Appl. No. 14/098,467", dated Mar. 28, 2014, p. 15, Published in: US.
- Gruber, Stephen S., "Response to Office Action re U.S. Appl. No. 14/098,467", dated Apr. 8, 2014, p. 13, Published in: US.
- Gruber, Stephen S., "Response to Office Action re U.S. Appl. No. 13/307,431", dated Oct. 4, 2013, p. 22, Published in: US.
- Gruber, Stephen S., "Response to Office Action re U.S. Appl. No. 13/307,431", dated Nov. 25, 2013, p. 22, Published in: US.
- Gruber, Stephen S., "Response to Office Action re U.S. Appl. No. 14/461,229", dated Dec. 11, 2014, p. 13, Published in: US.
- Dobbin, Geoffrey, "Response to Office Action re U.S. Appl. No. 13/307,431", dated Mar. 14, 2013, p. 10, Published in: US.
- Steyr Mannlicher International, "Product Page for Steyr AUG 30 Round Black Magazine", Oct. 9, 2013, p. 3, Publisher: Page downloaded from <http://www.steyrarms.com/store/index.php/magazines/auto-5.html> downloaded on, Published in: US.
- "Teppa Chart re U.S. Pat. No. 4,589,218", p. 28, Published in: US.
- Fitzpatrick, et al., "Specification for related U.S. Appl. No. 14/098,467", filed Dec. 5, 2013, p. 21, Published in: US.
- Fitzpatrick, et al., "Specification for related U.S. Appl. No. 60/941,646", filed Jun. 1, 2007, p. 7, Published in: US.
- "Westrom Chart re U.S. Pat. No. 5,638,626", p. 21, Published in: US.
- Tactical Testing & Evaluation, LLC. "Magpul PMAG." Oct. 14, 2007. Retrieved from <http://ttellc.net/pmag.htm>.

* cited by examiner

FIG. 1

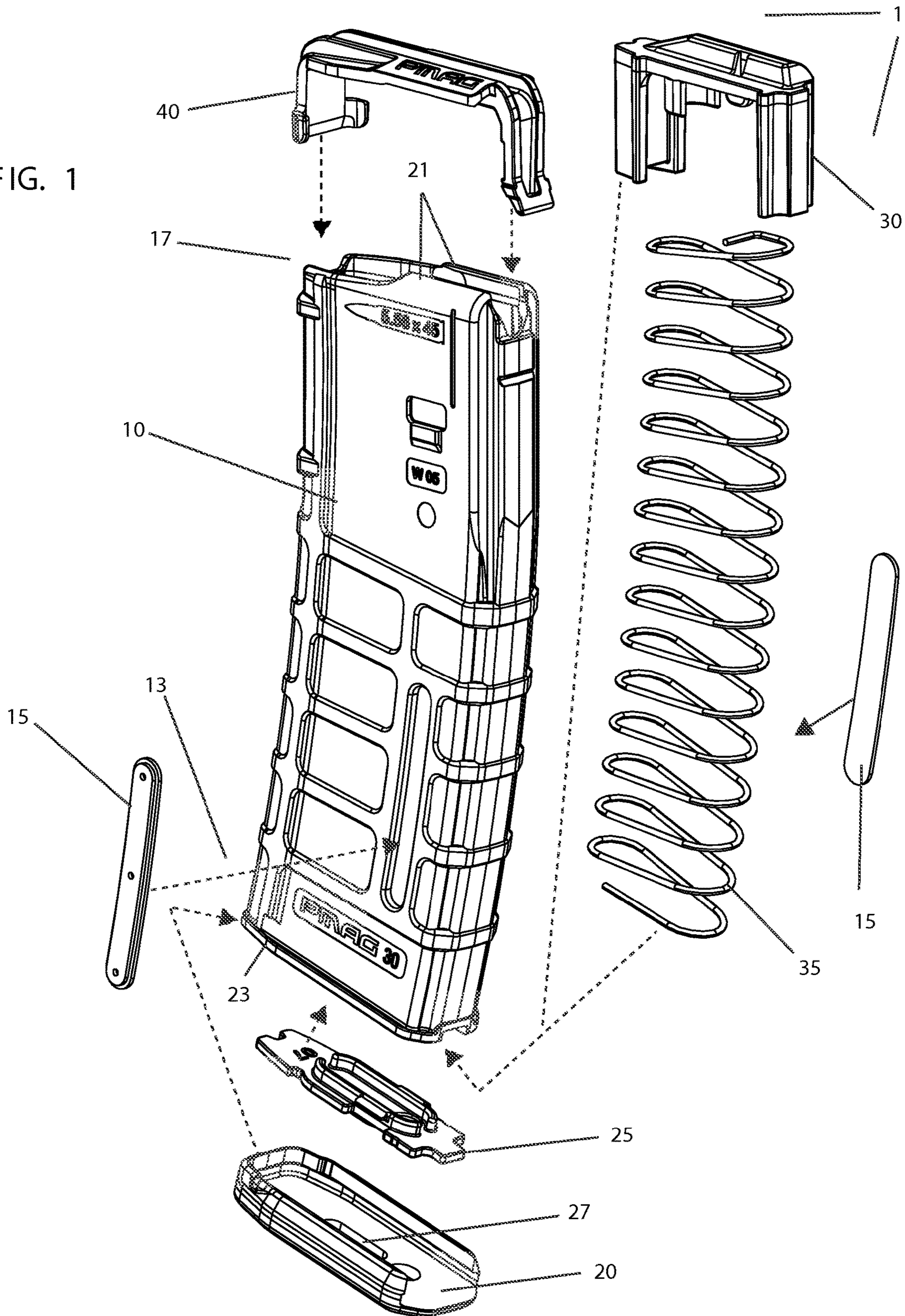

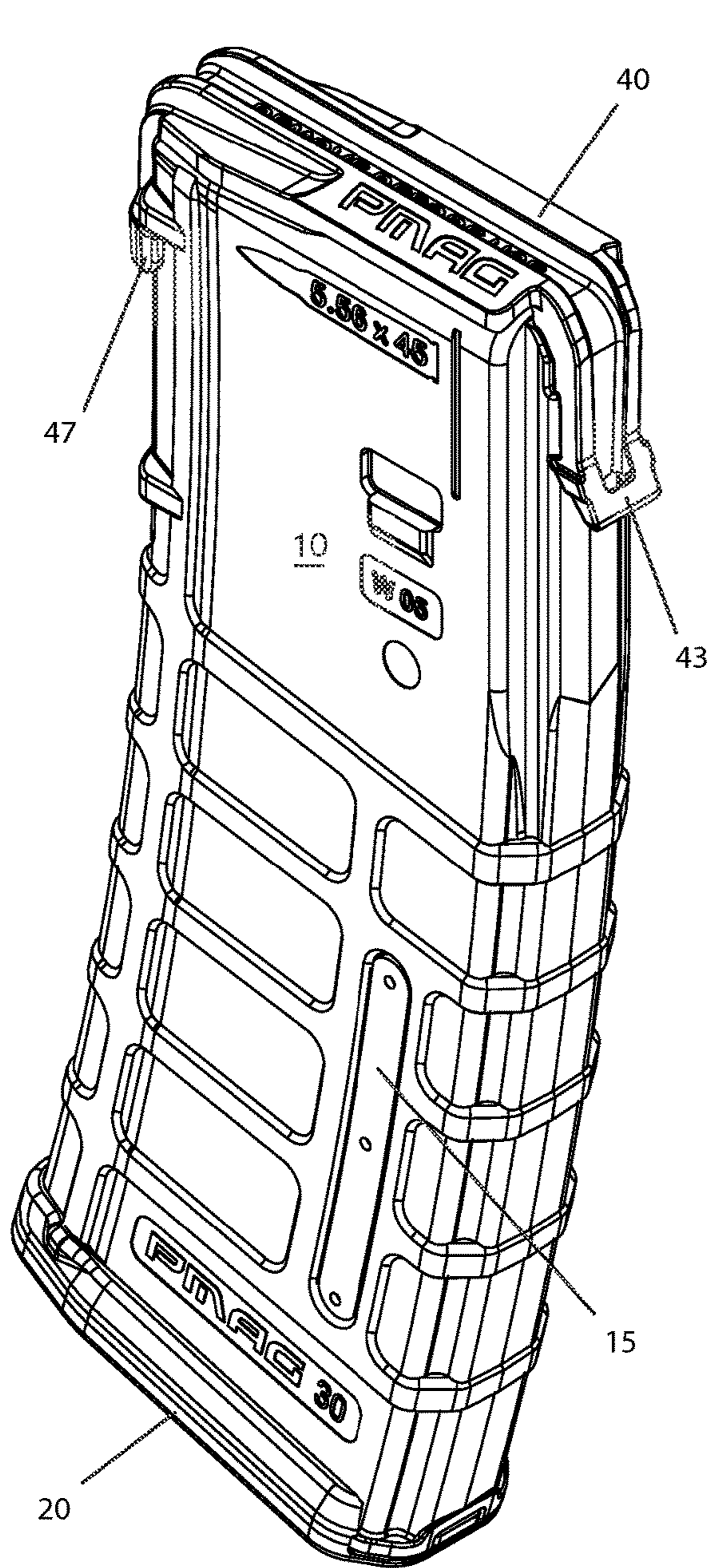

FIG. 2

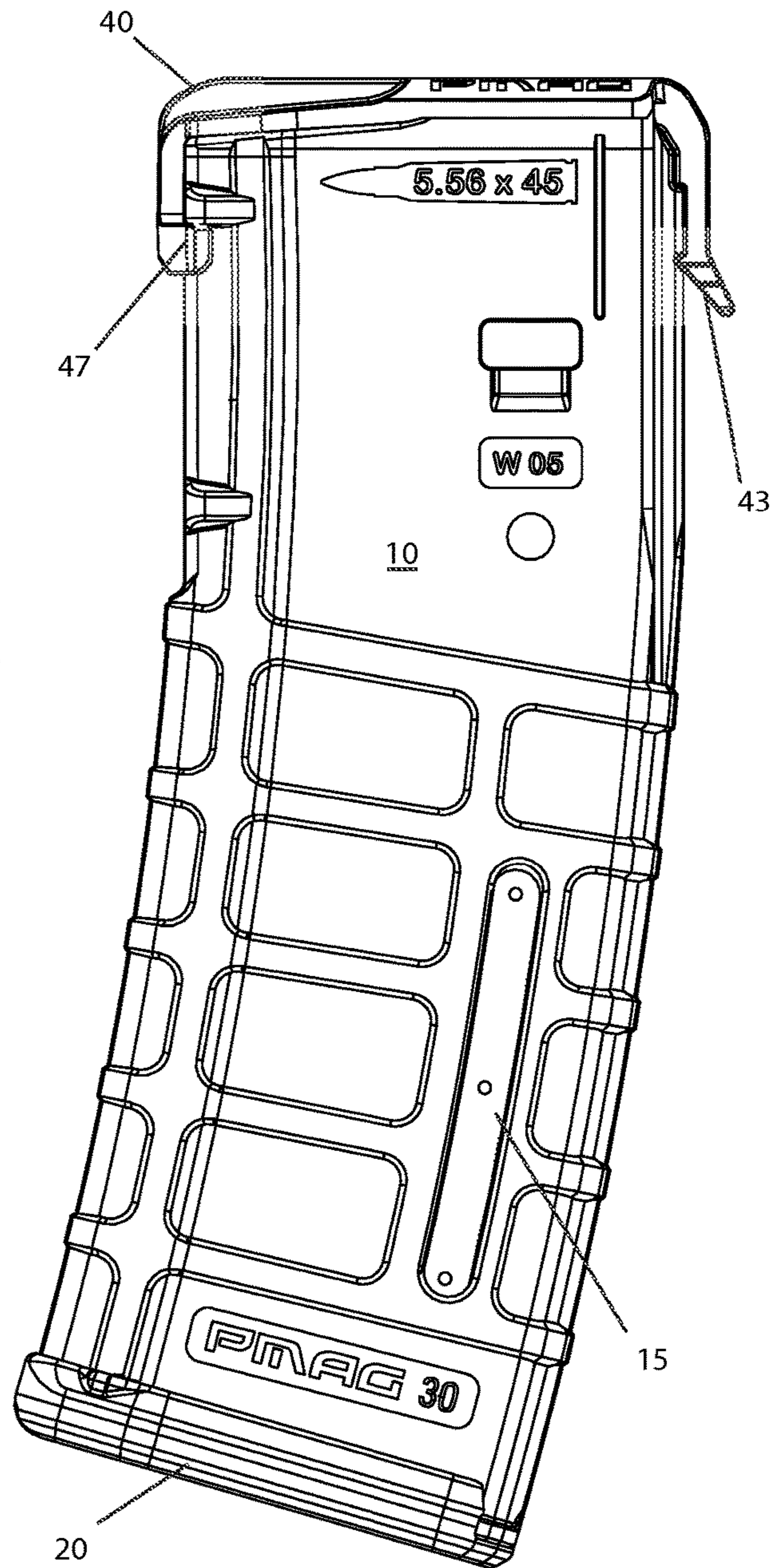
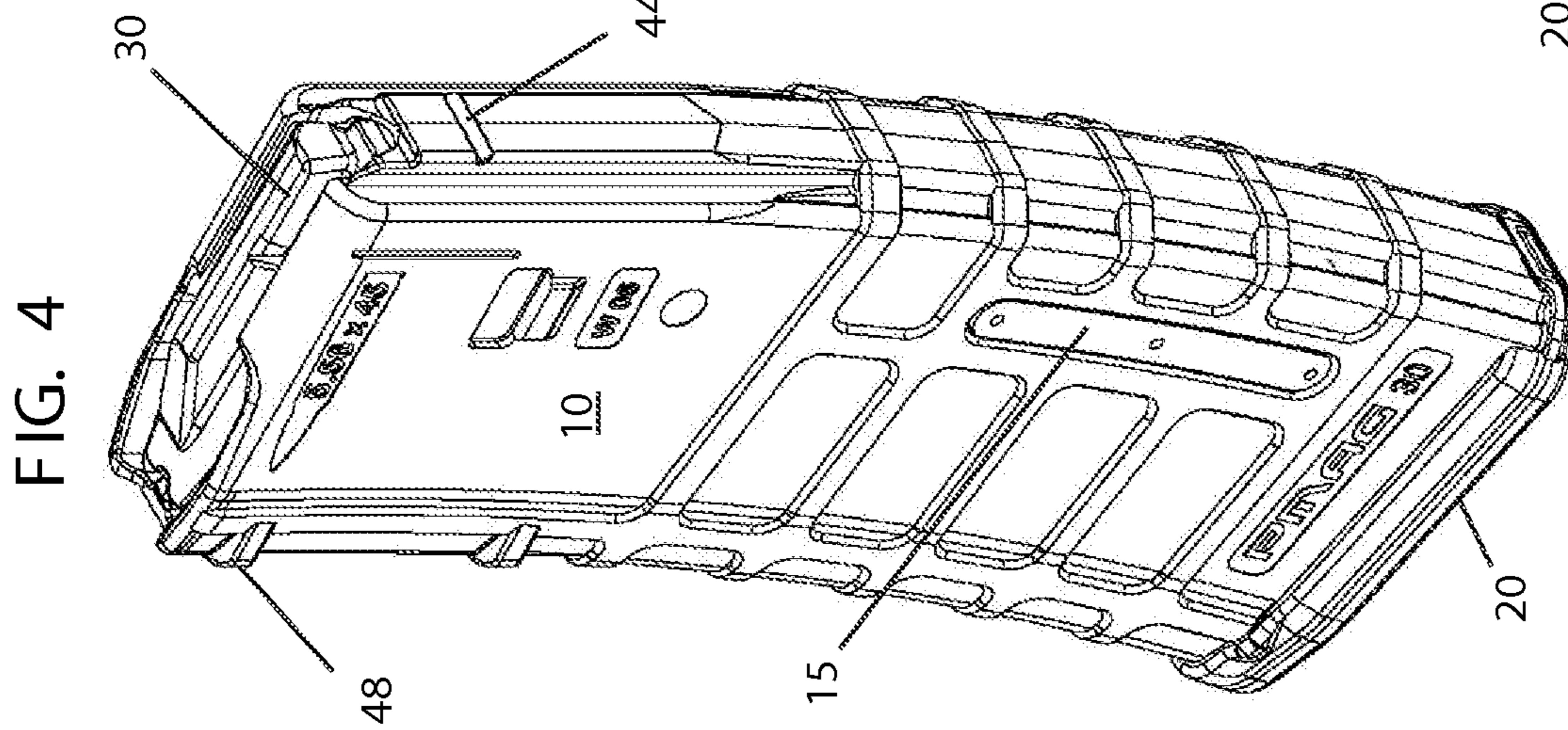
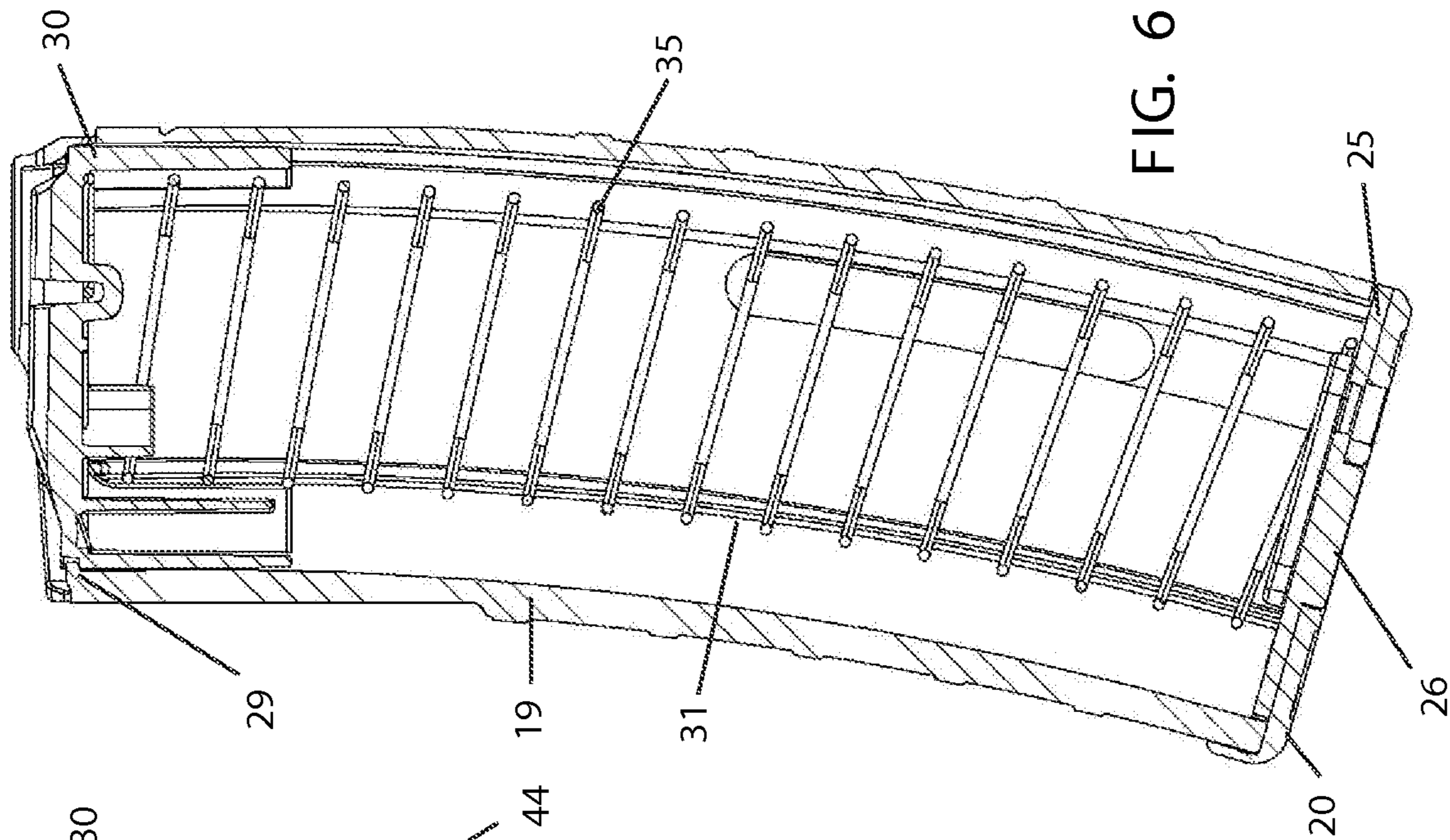
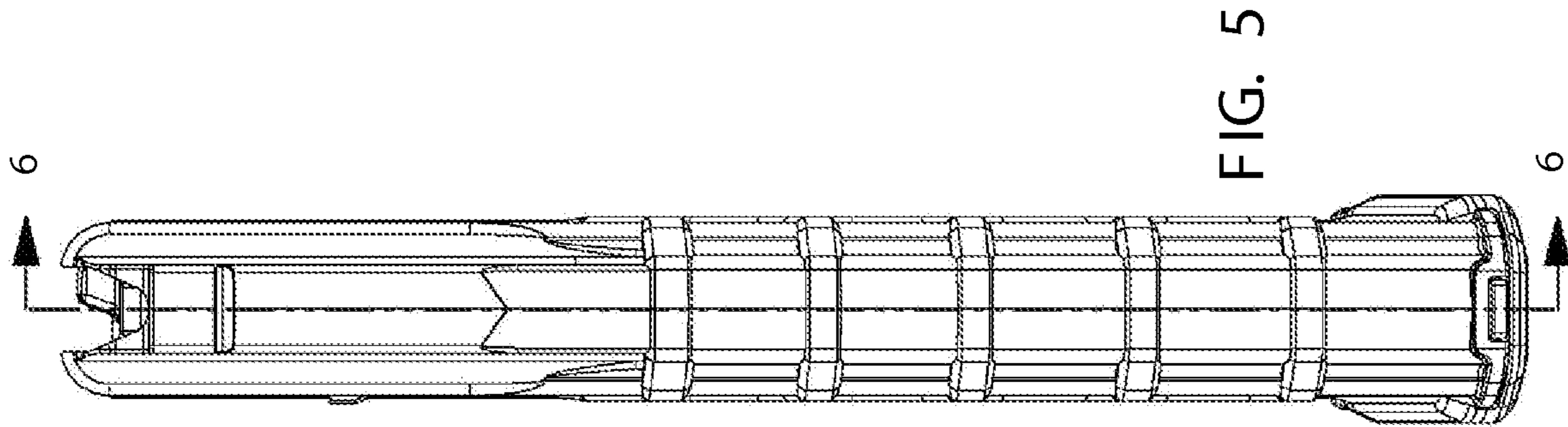

FIG. 3



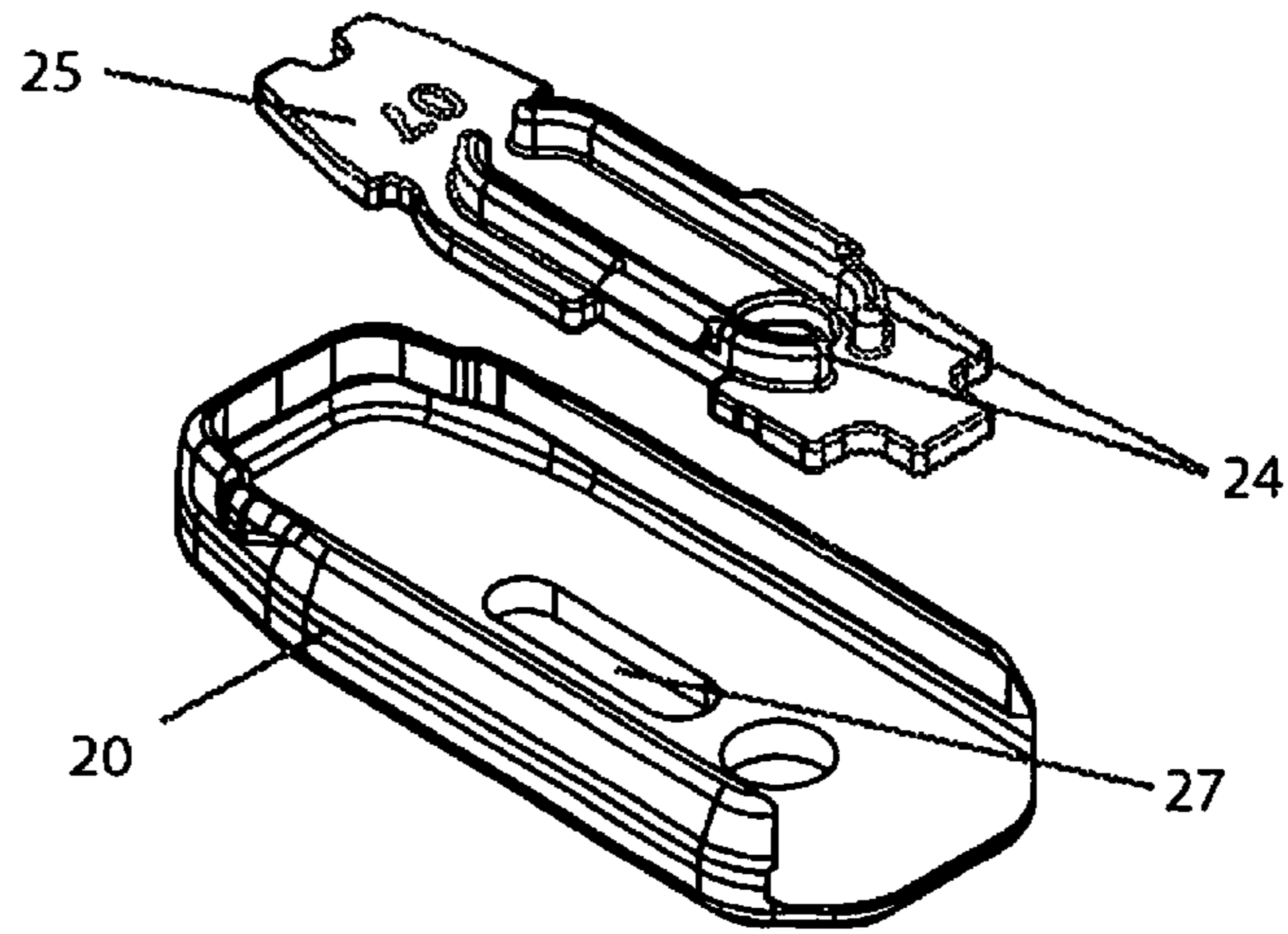

FIG. 6a

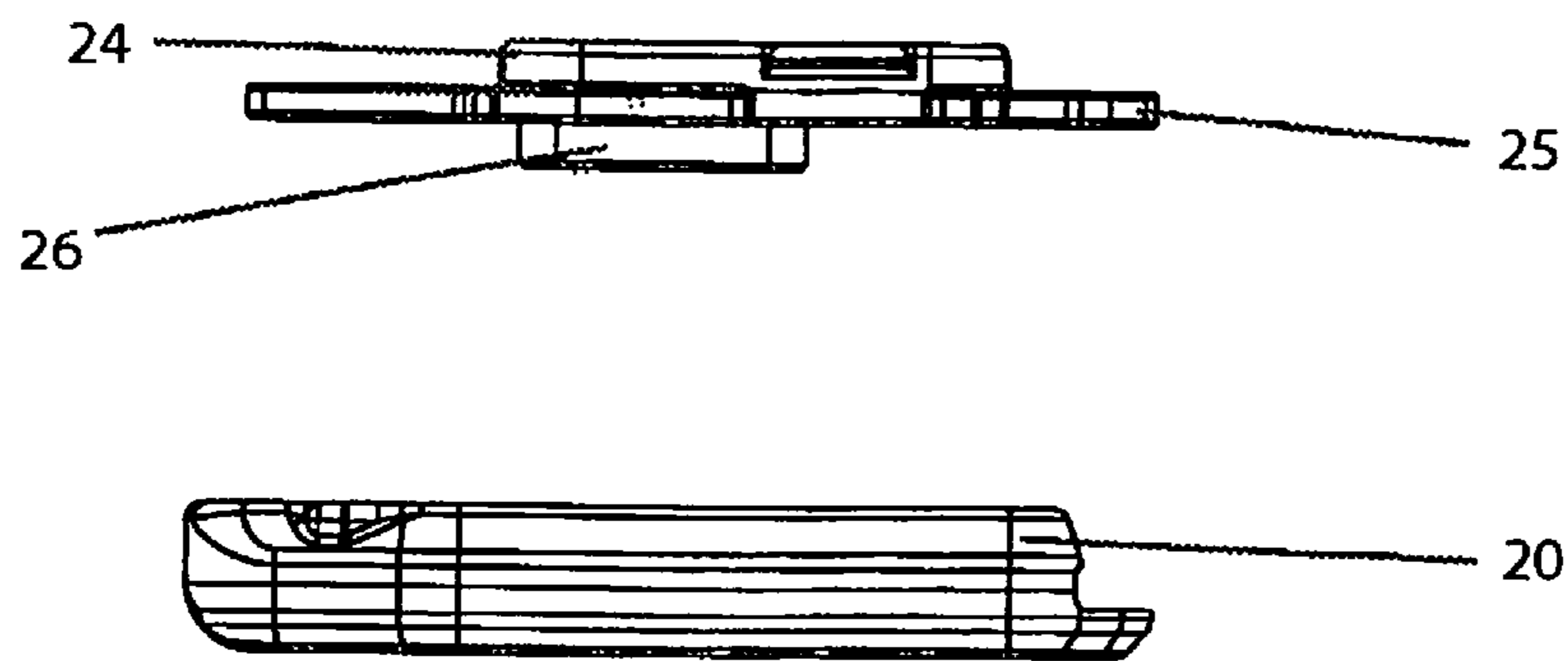

FIG. 6b

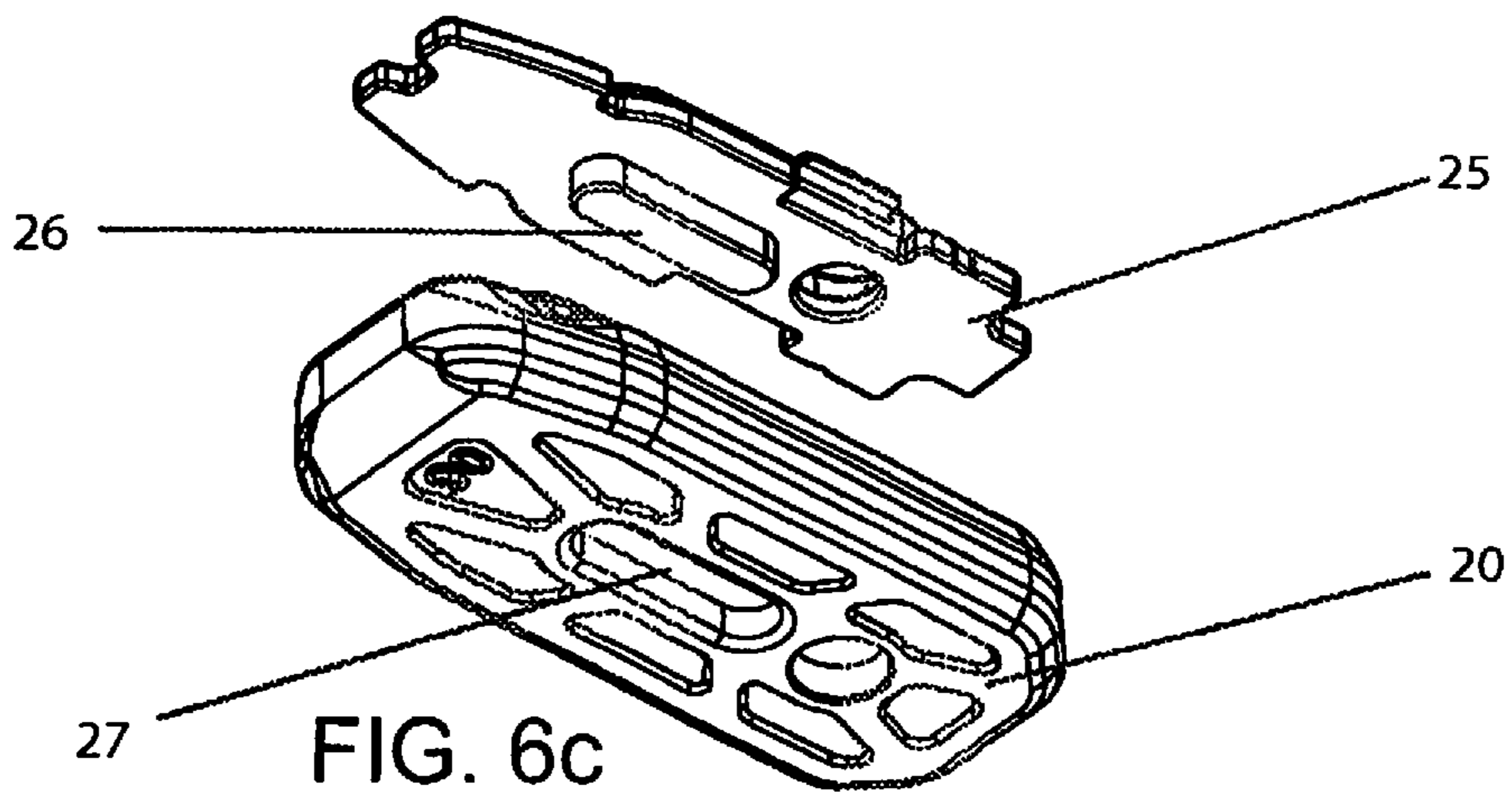
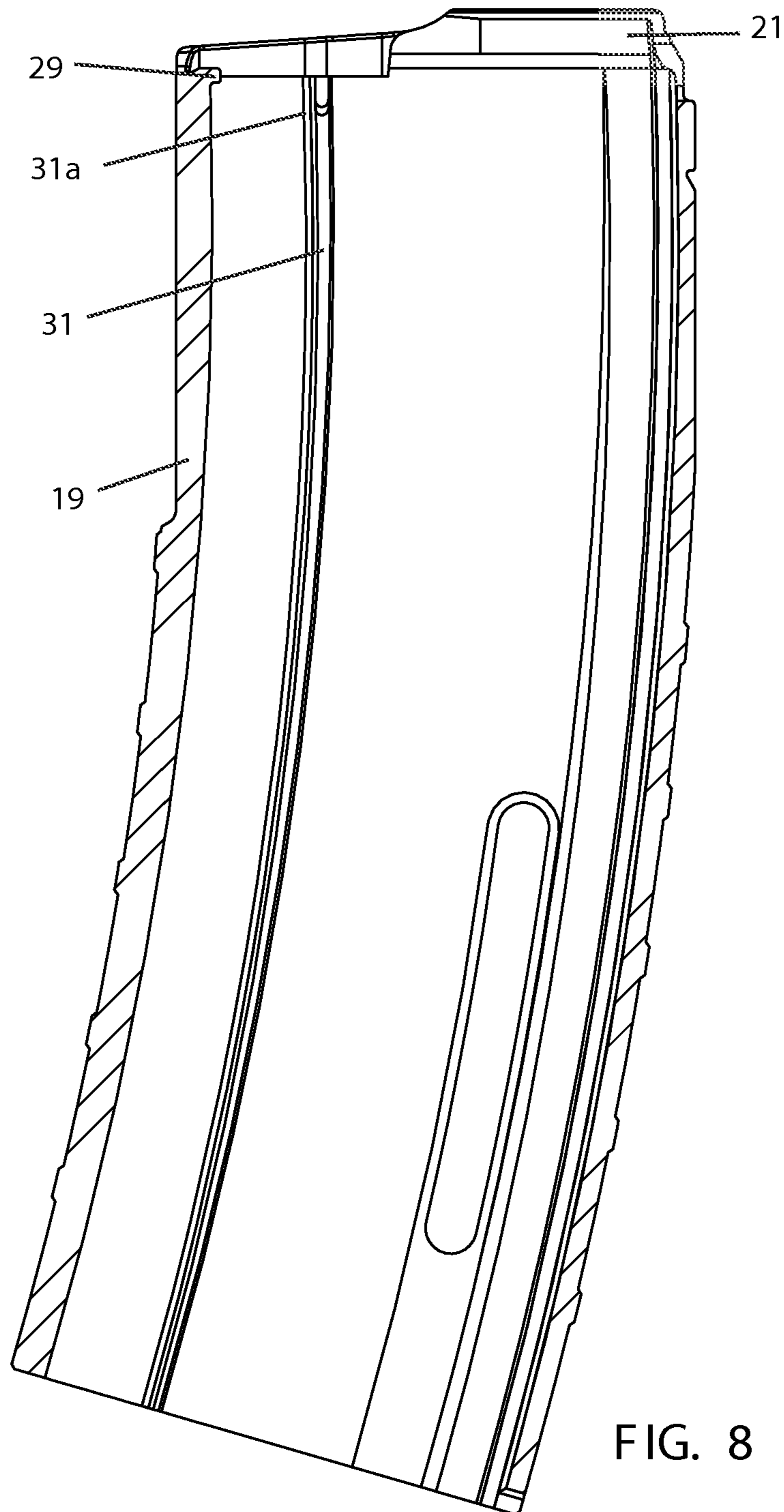
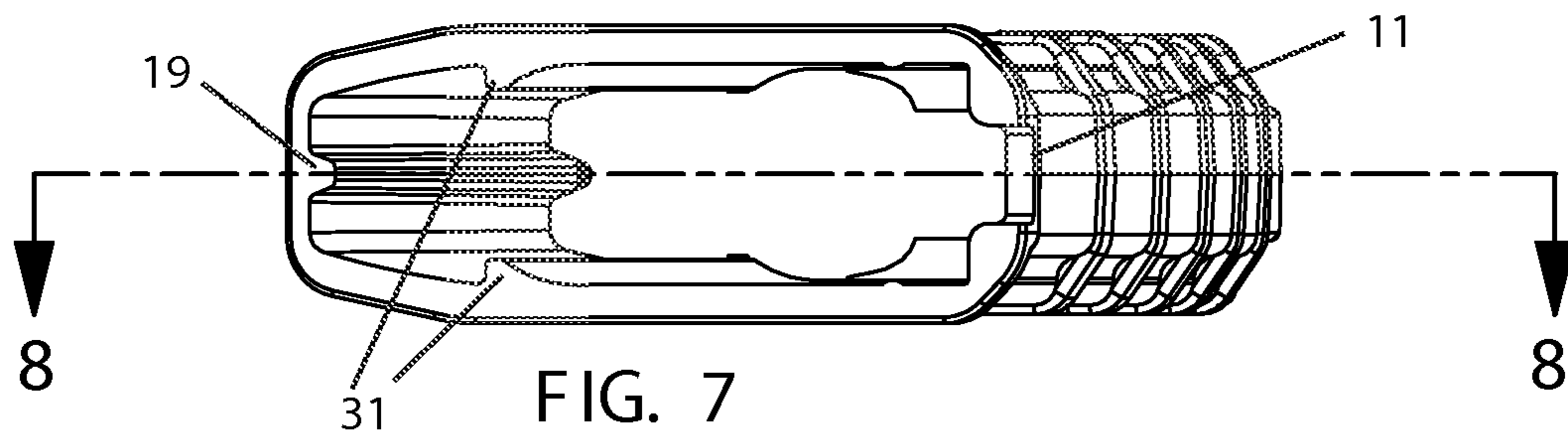

FIG. 6c



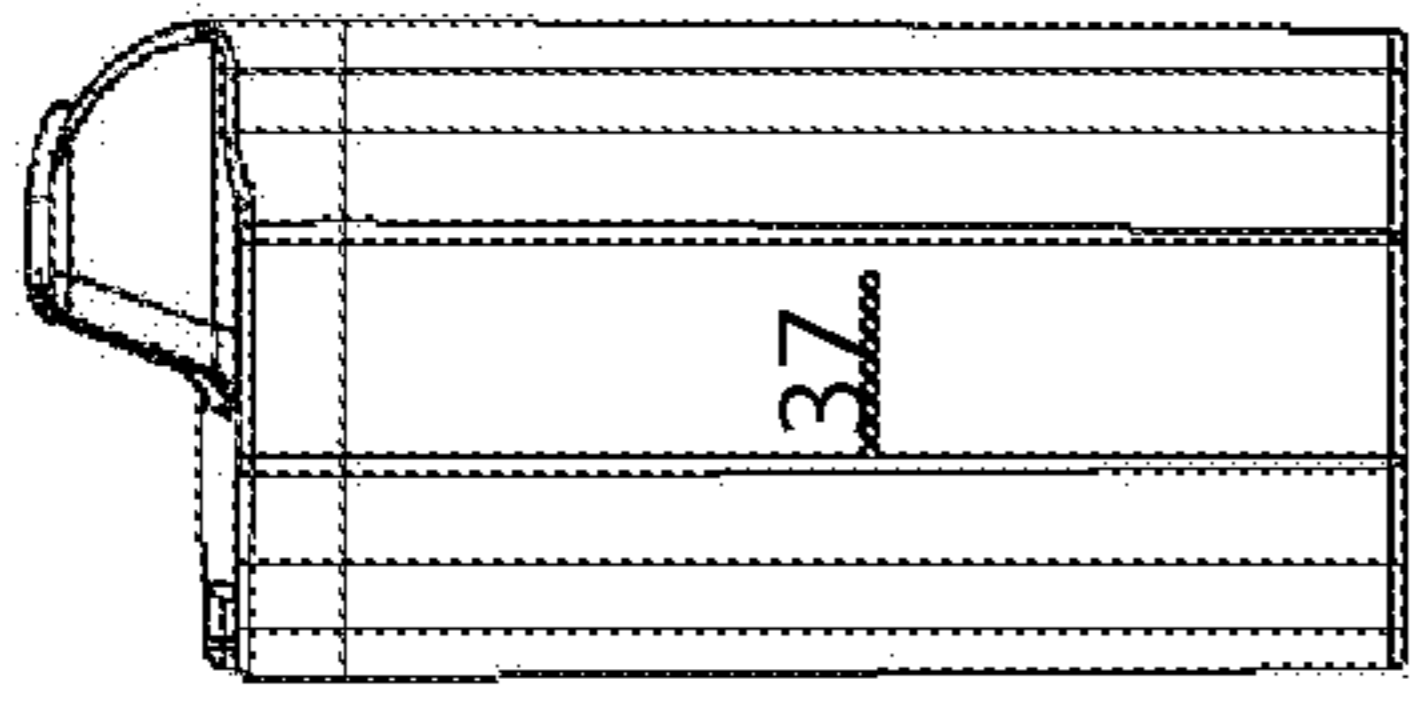

FIG. 9c

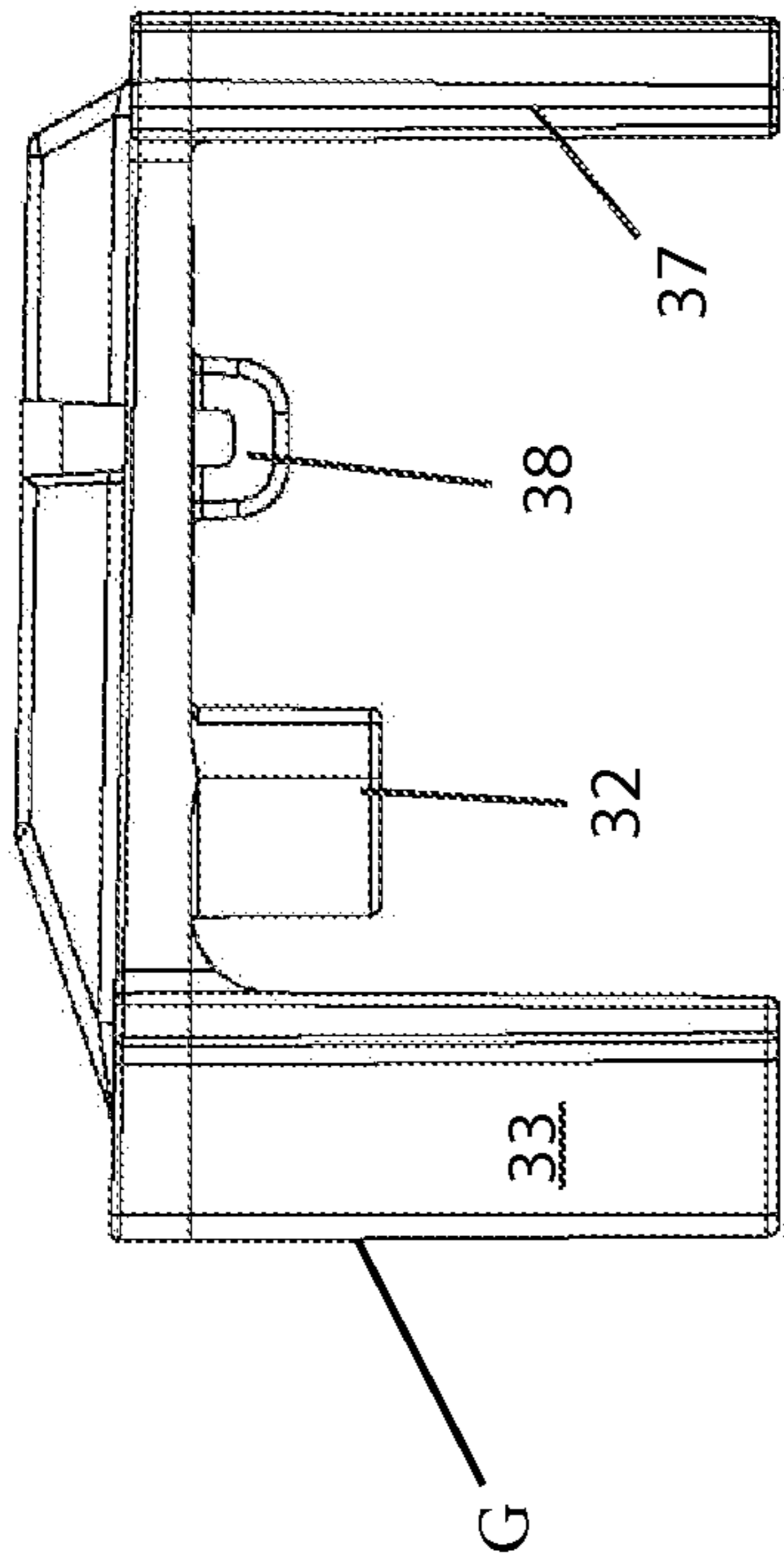

FIG. 9a

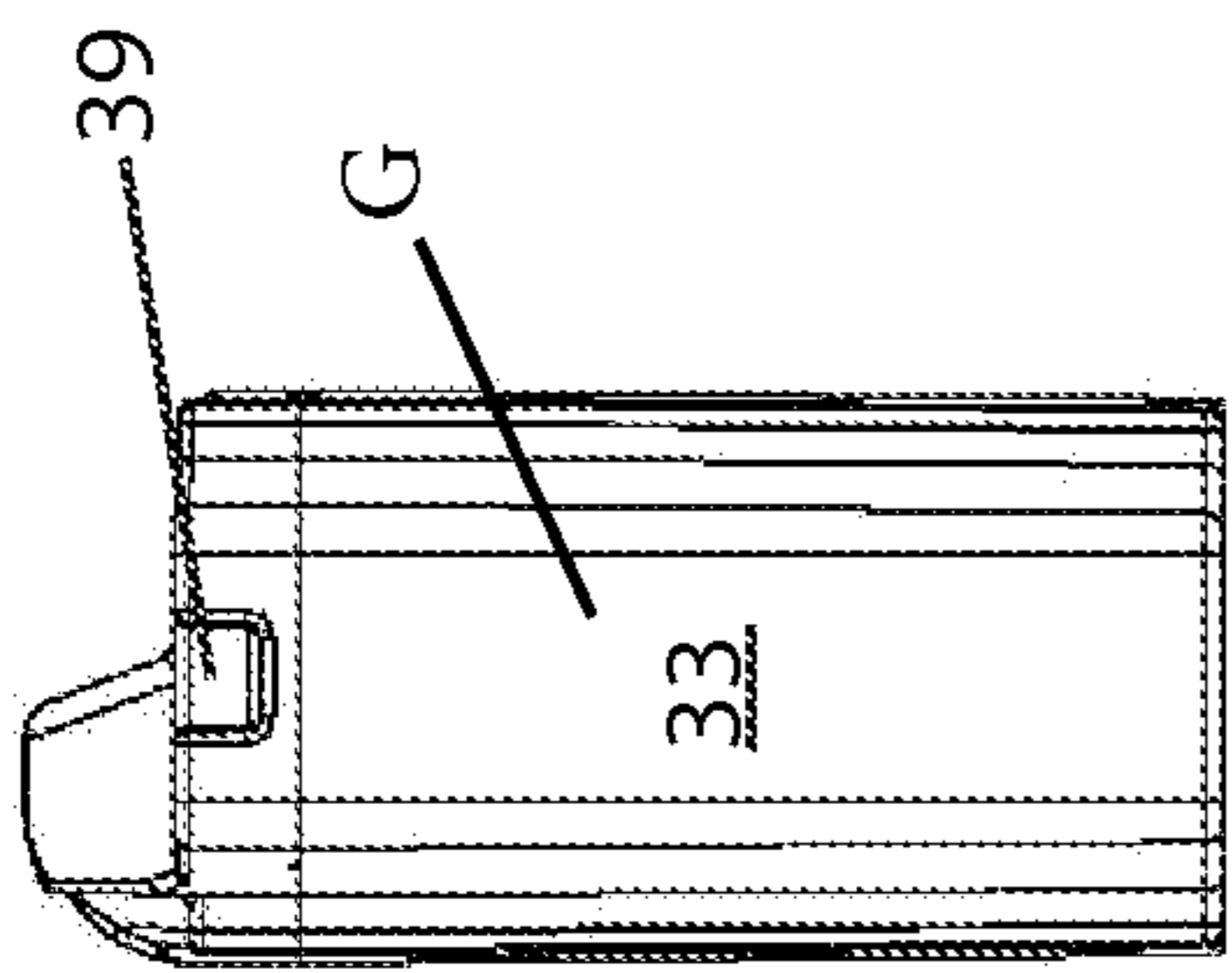

FIG. 9b

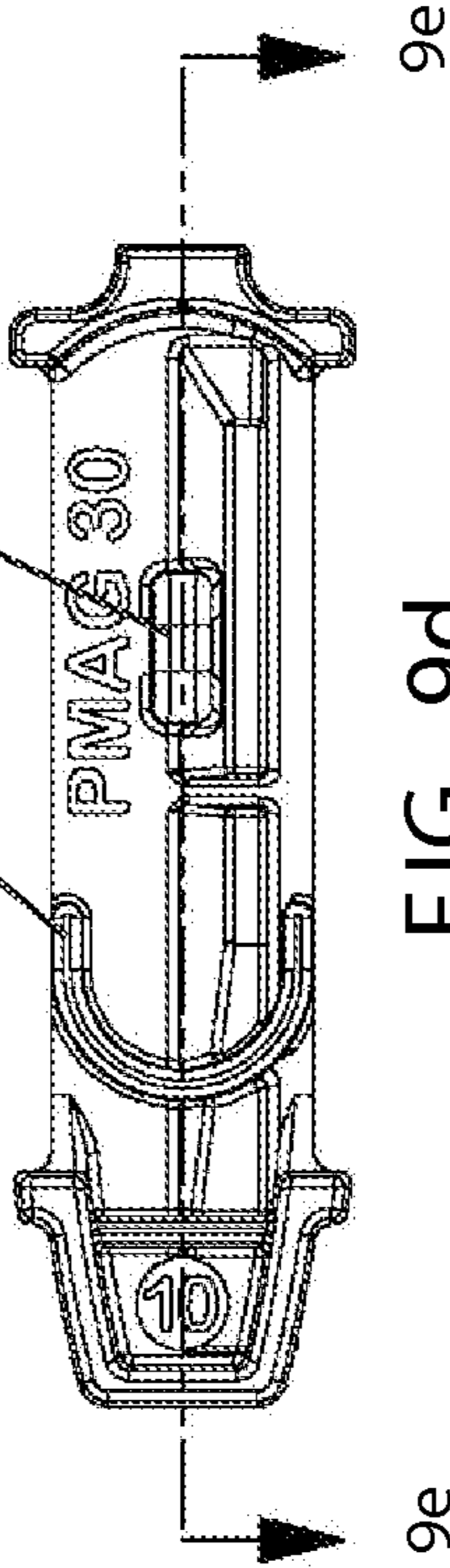

FIG. 9d

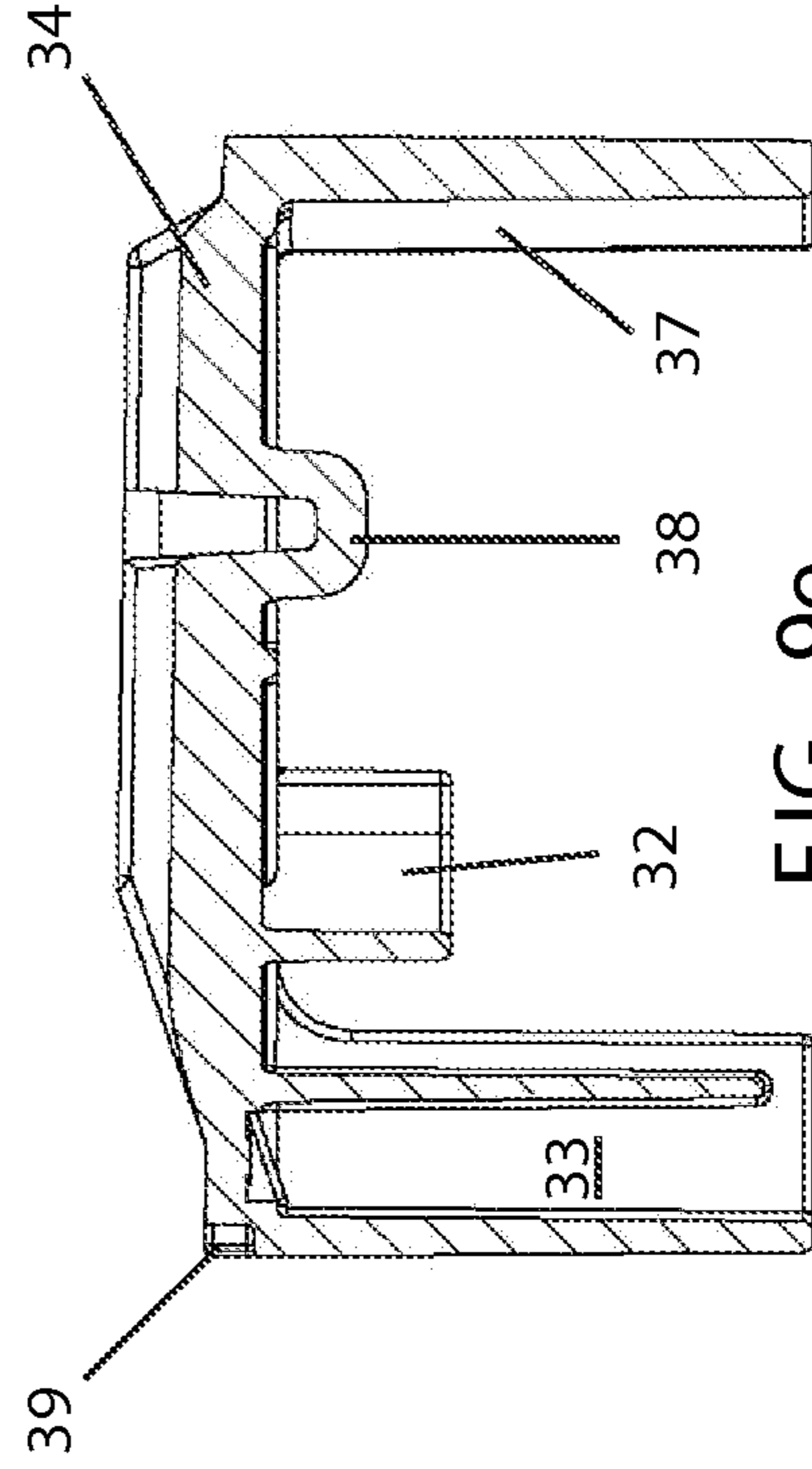

FIG. 9e

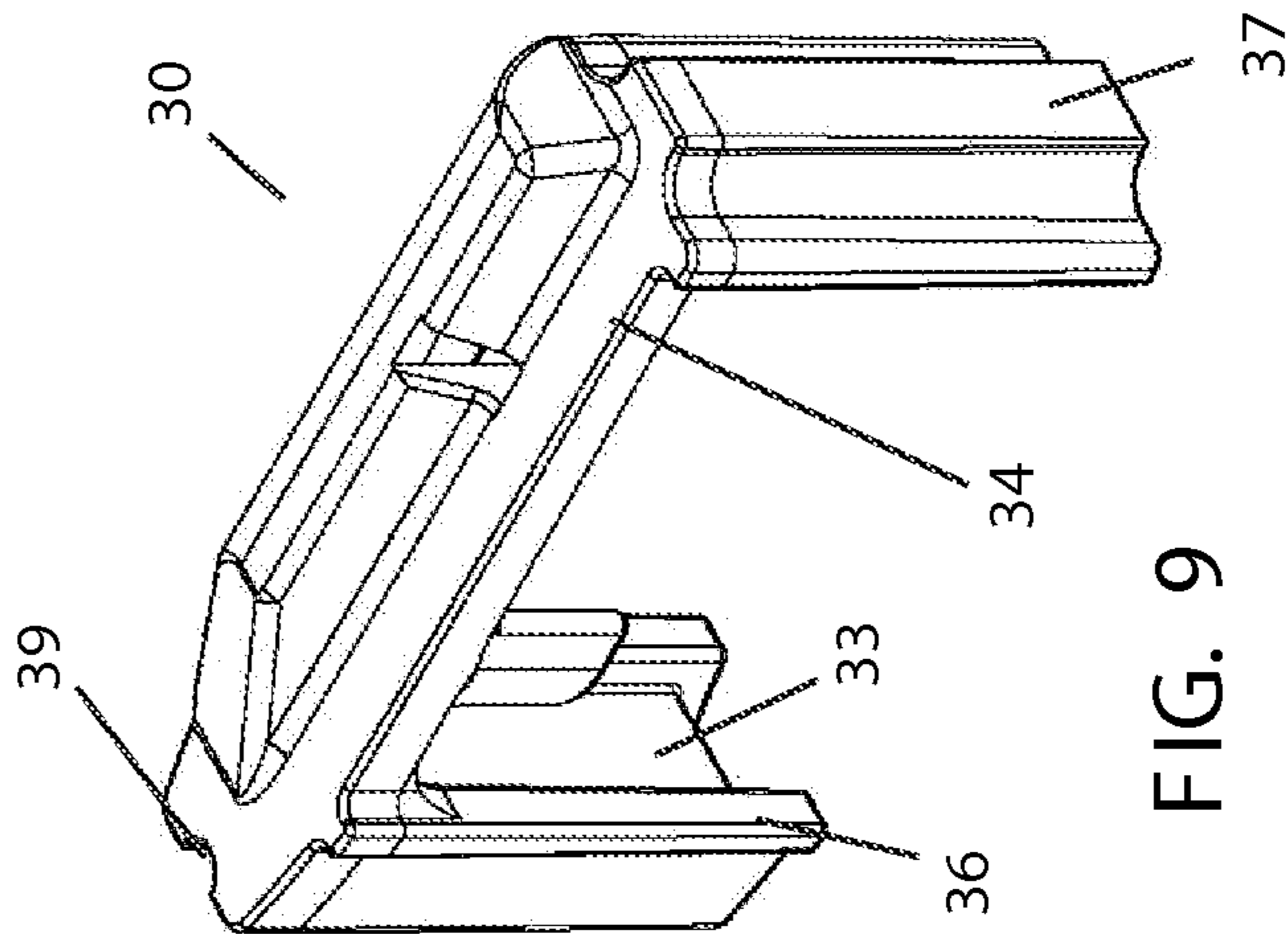

FIG. 9

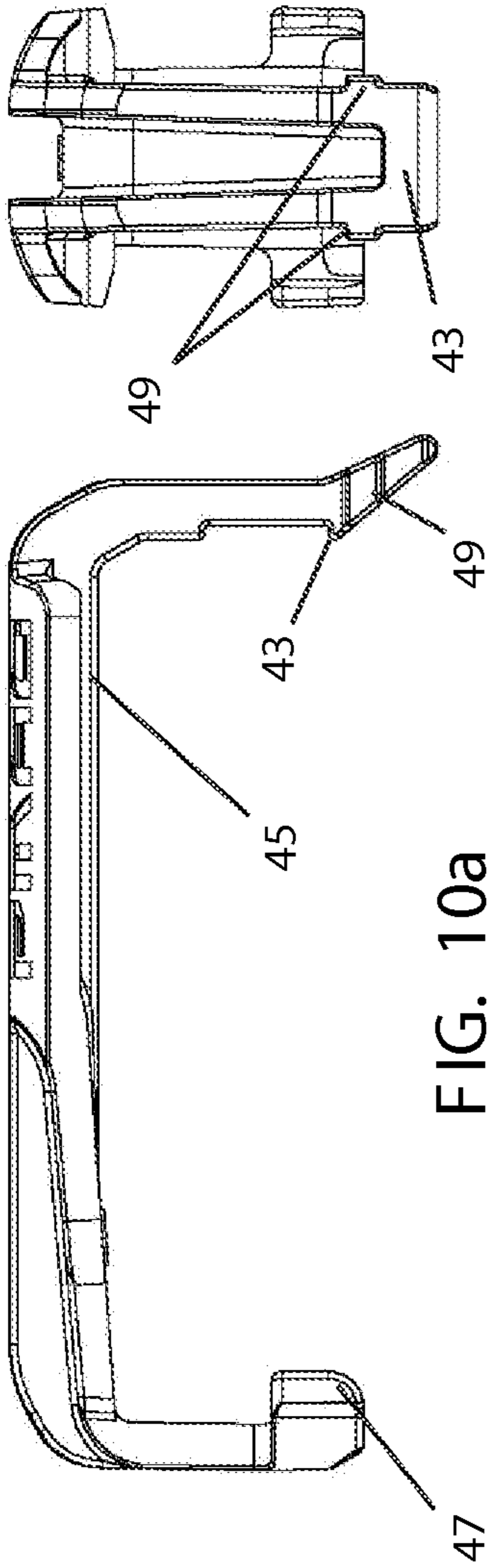

FIG. 10a

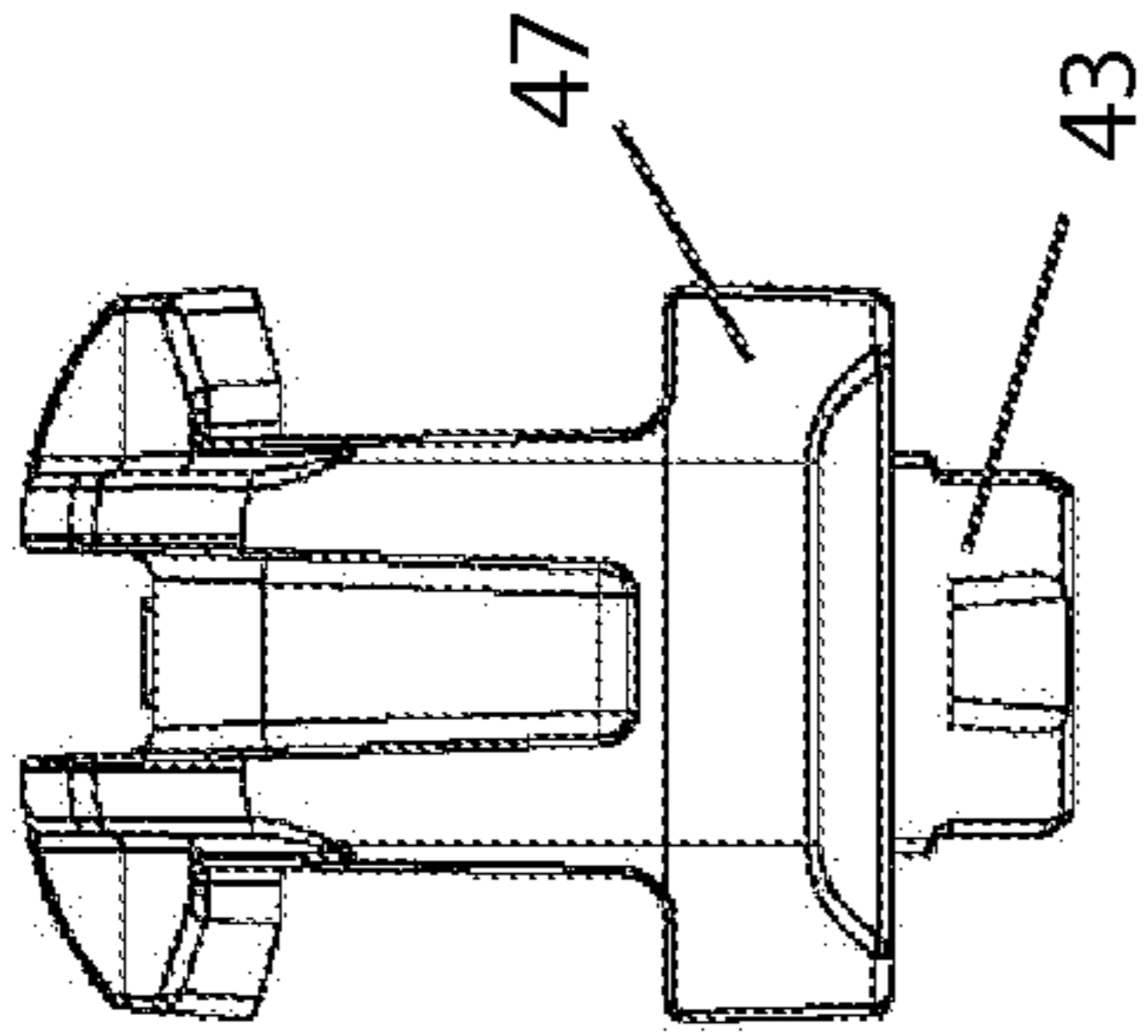

FIG. 10b

FIG. 10c

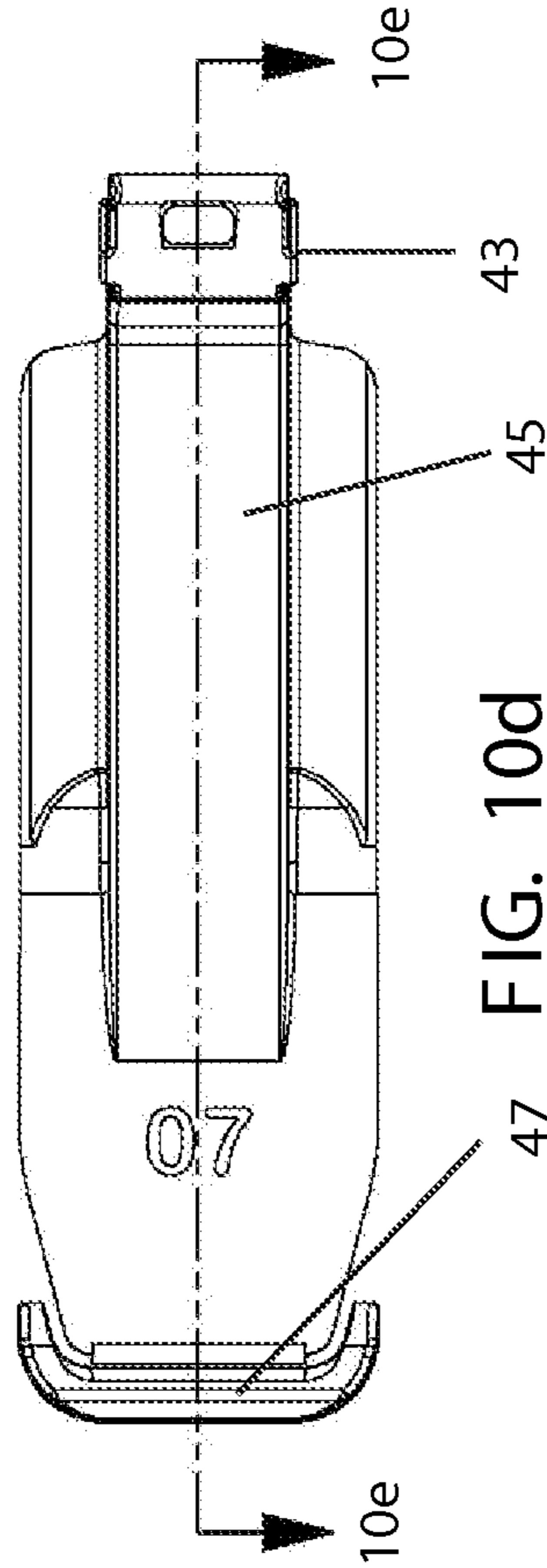

FIG. 10d

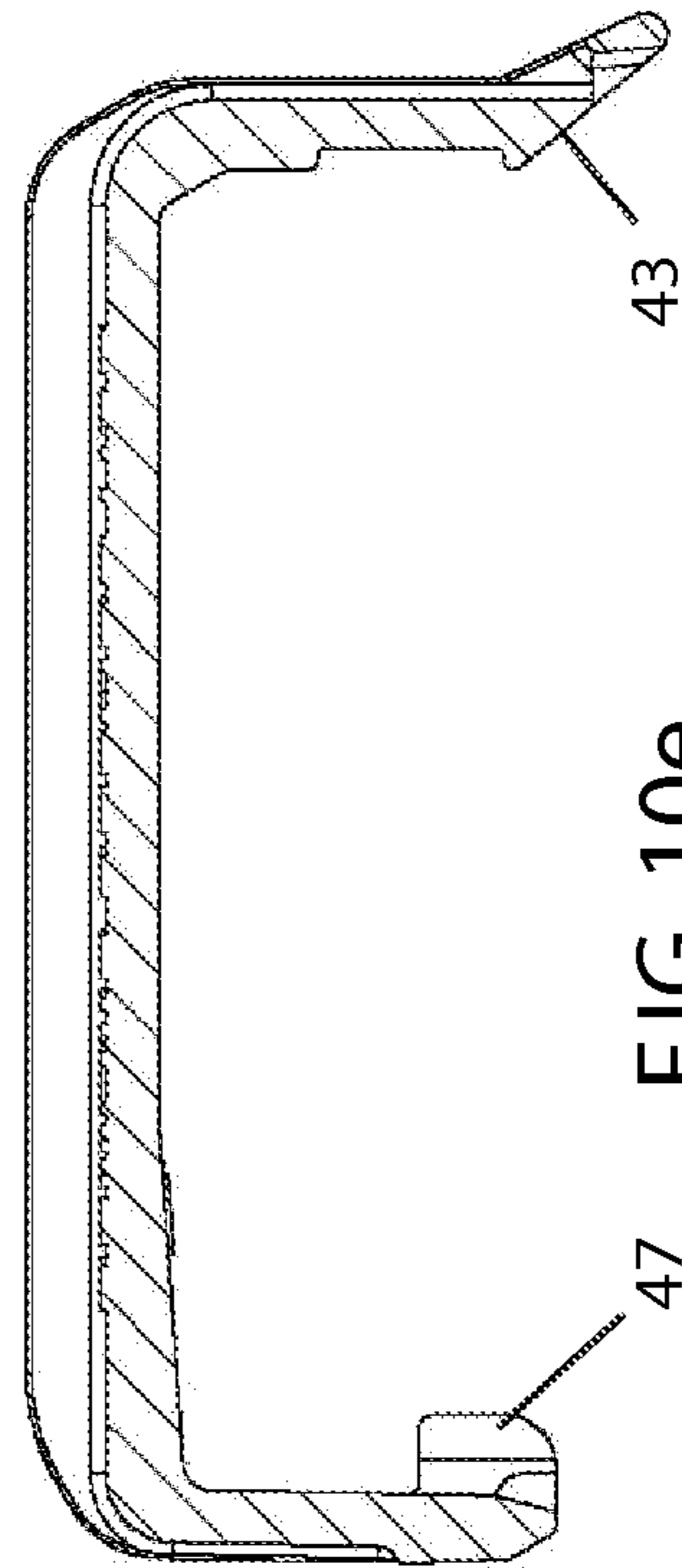

FIG. 10e

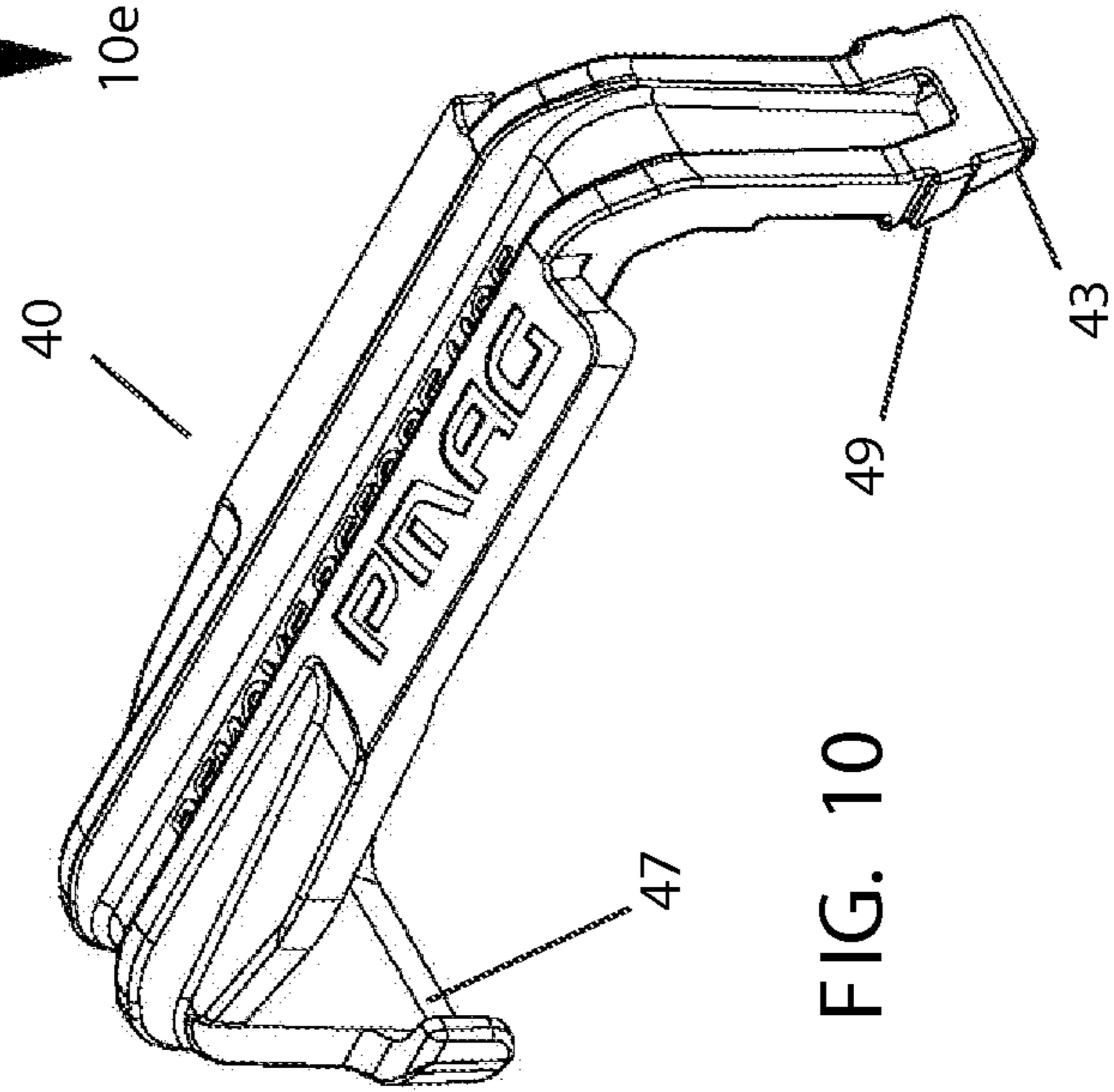

FIG. 10

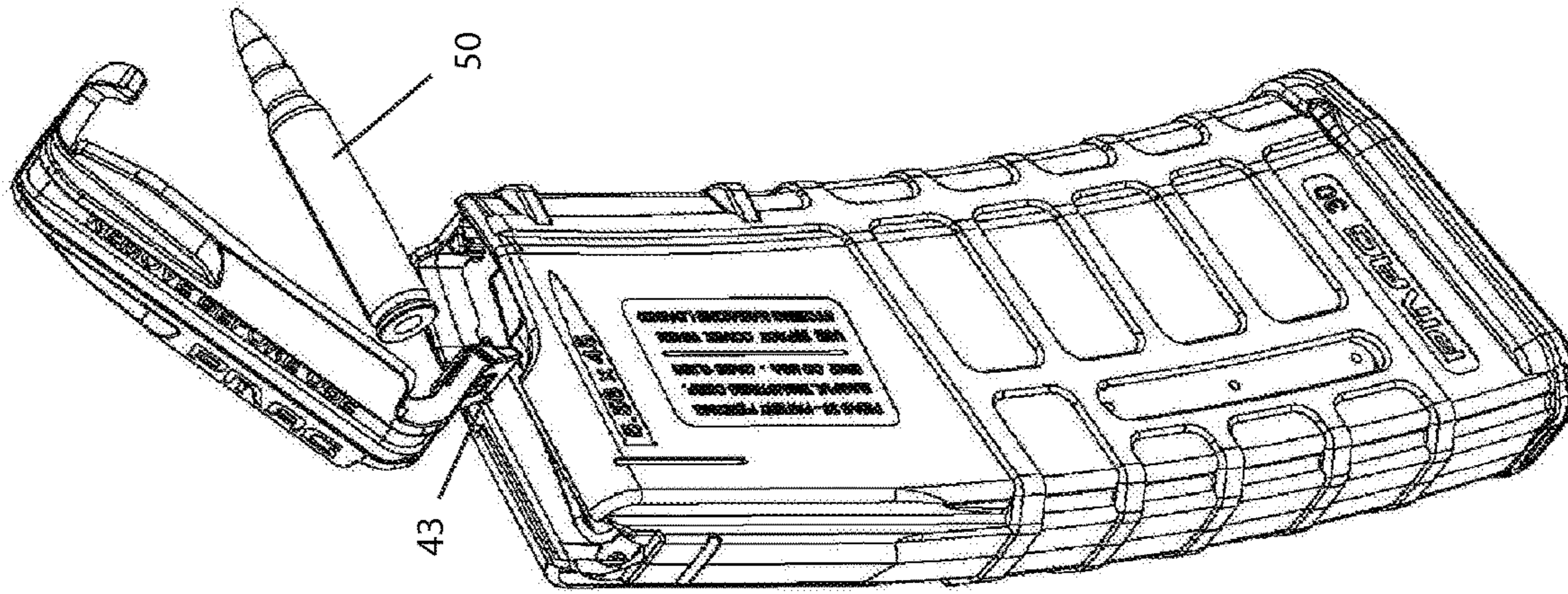

FIG. 11c

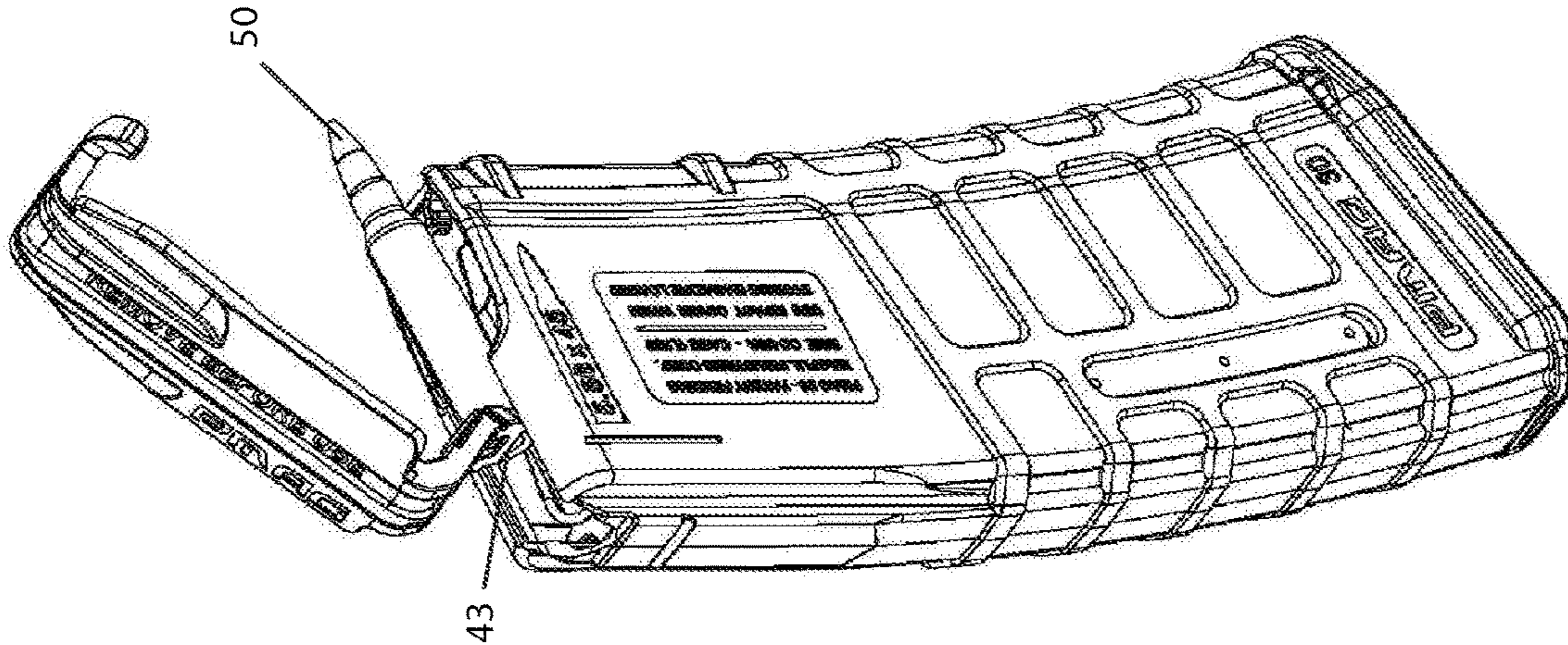

FIG. 11b

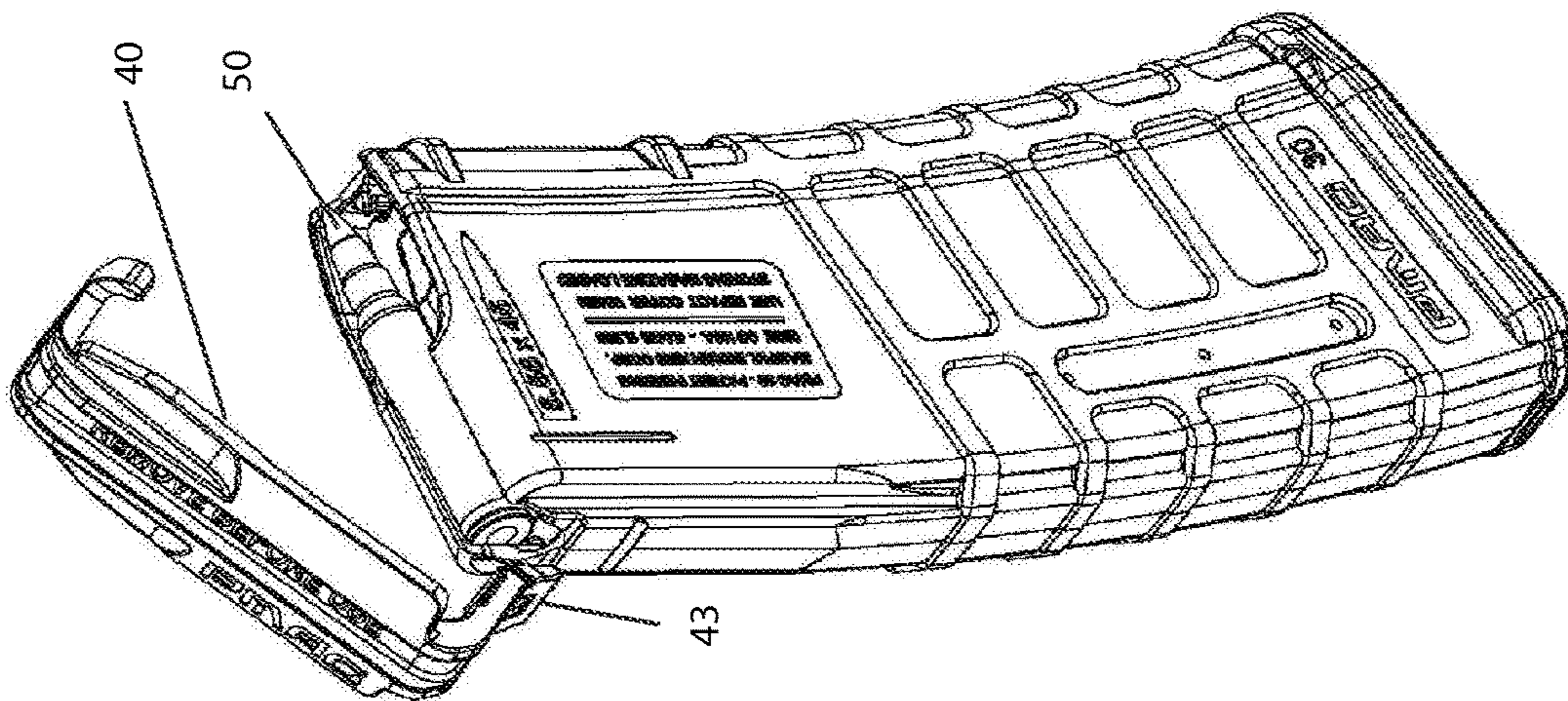

FIG. 11a

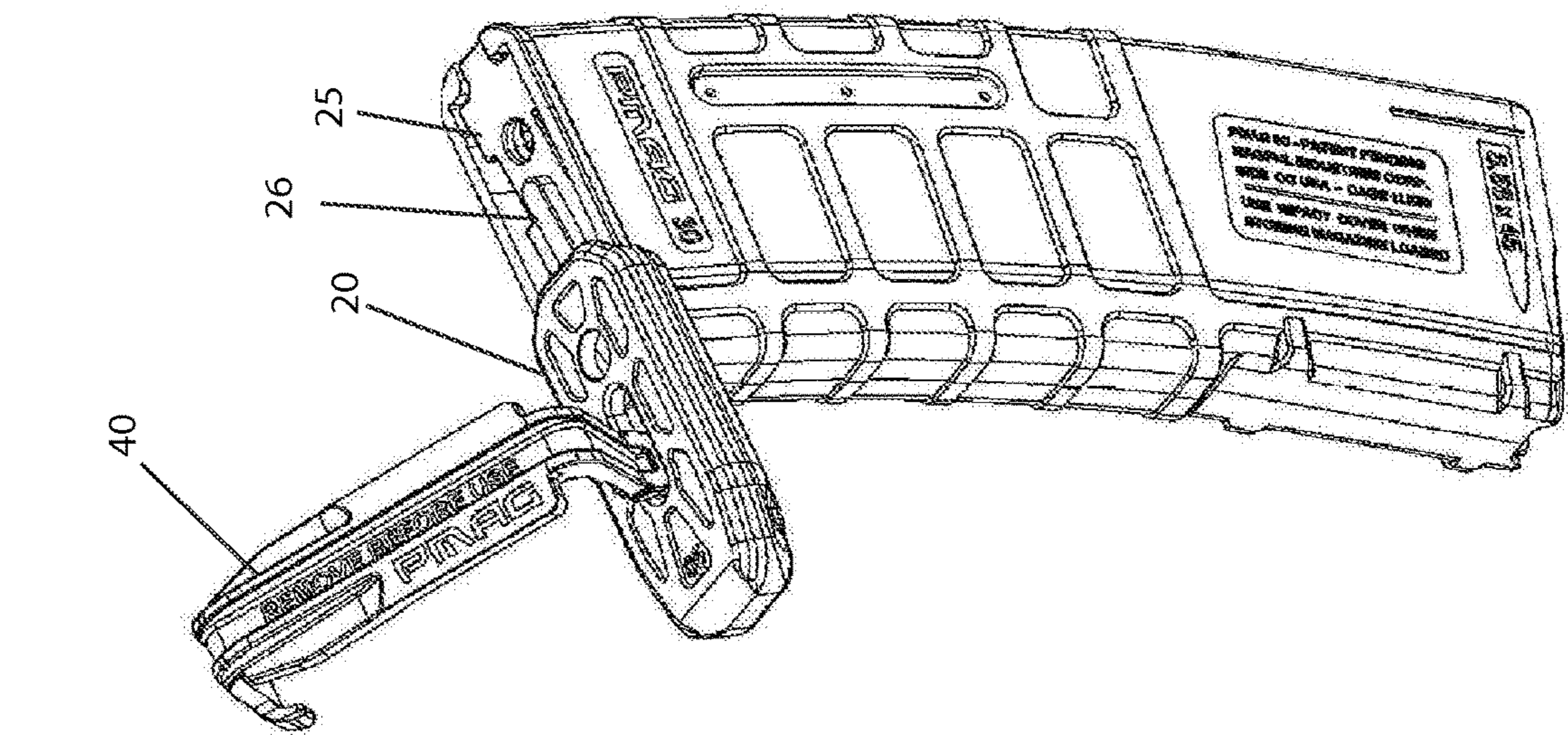

FIG. 12c

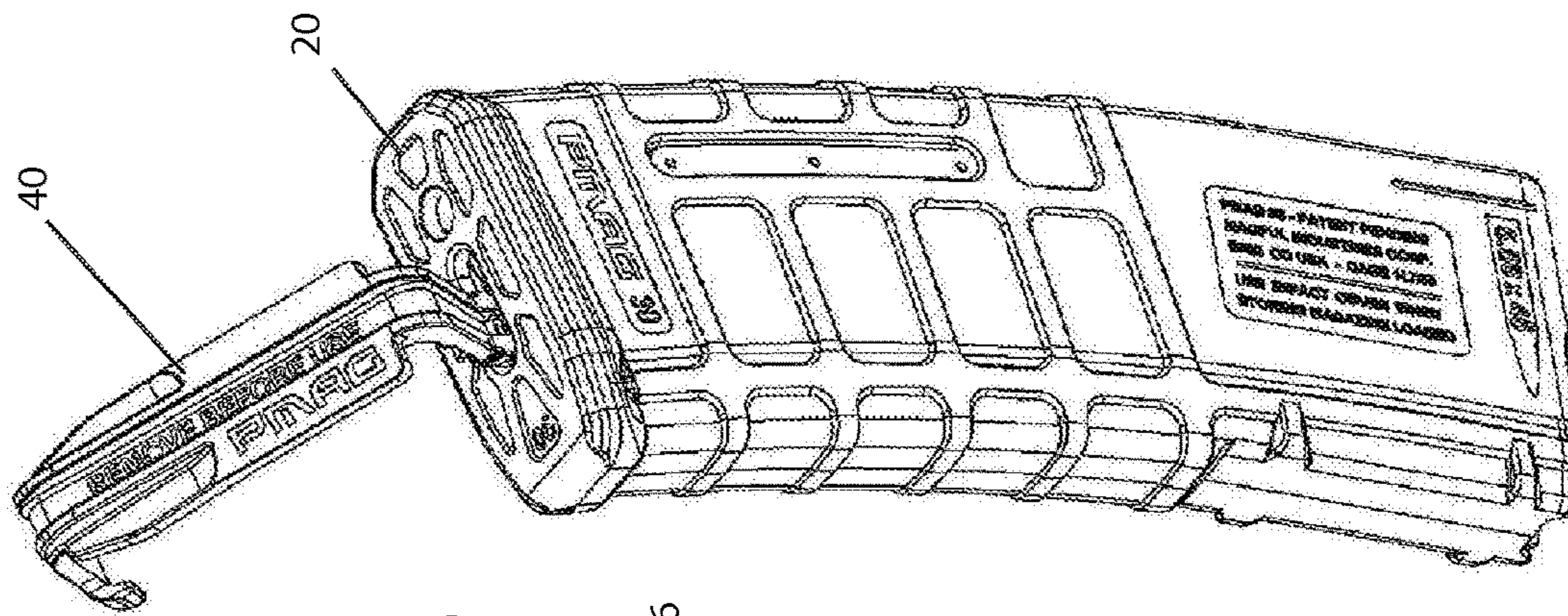

FIG. 12b

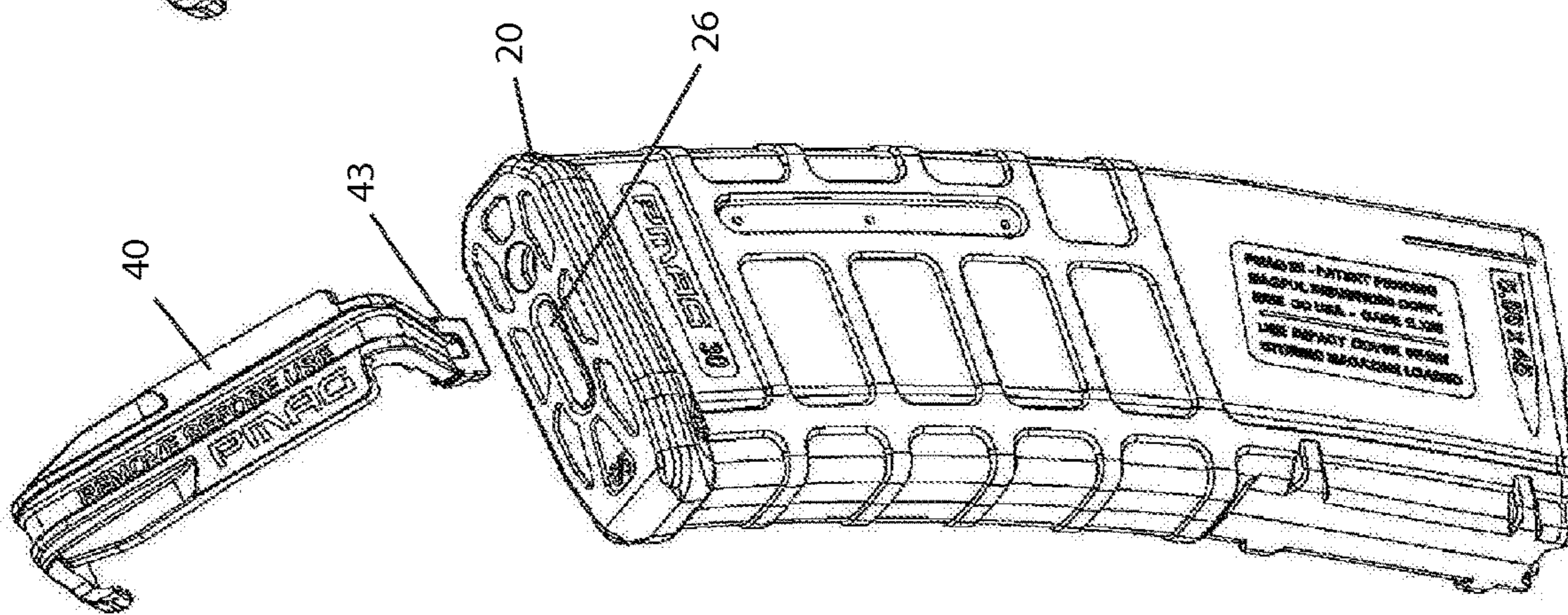

FIG. 12a

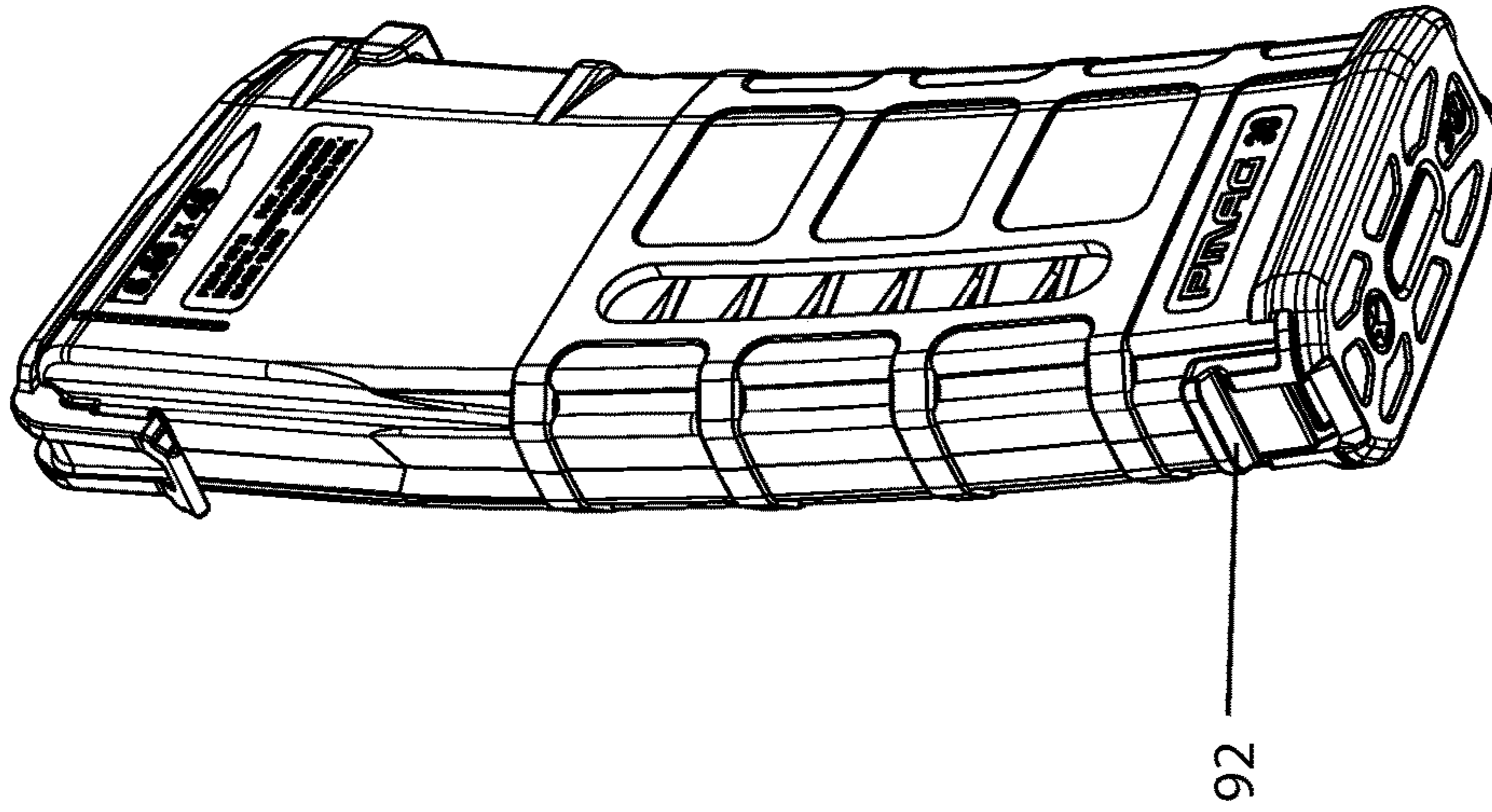

FIG. 14

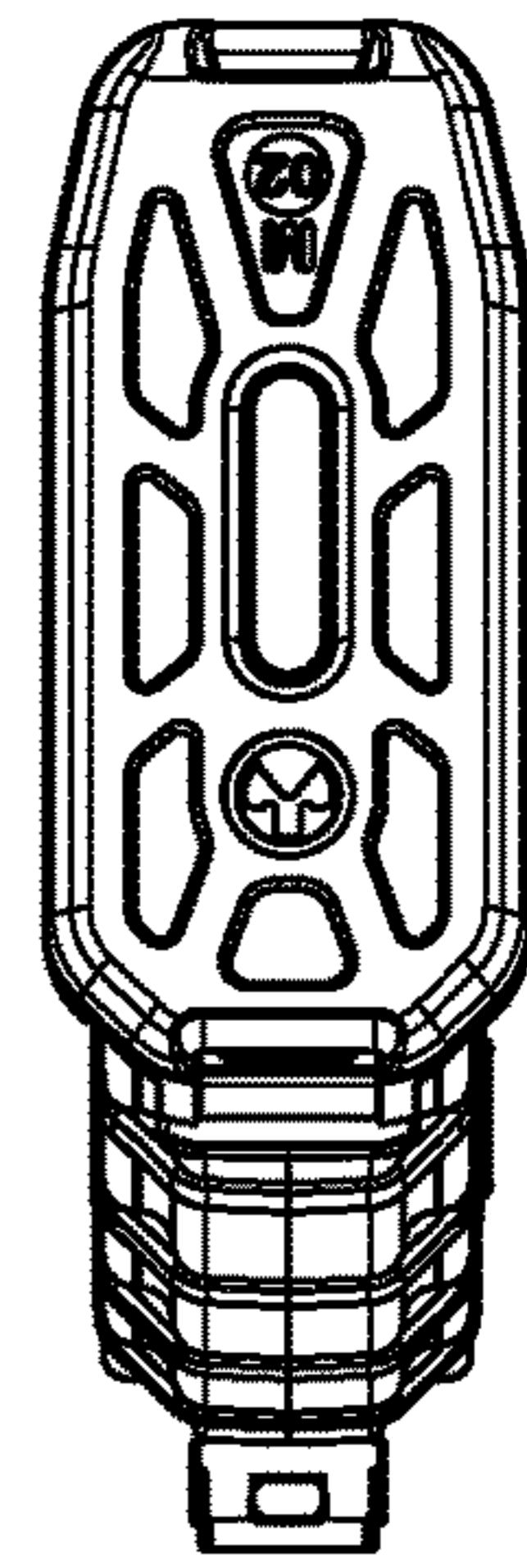

FIG. 15

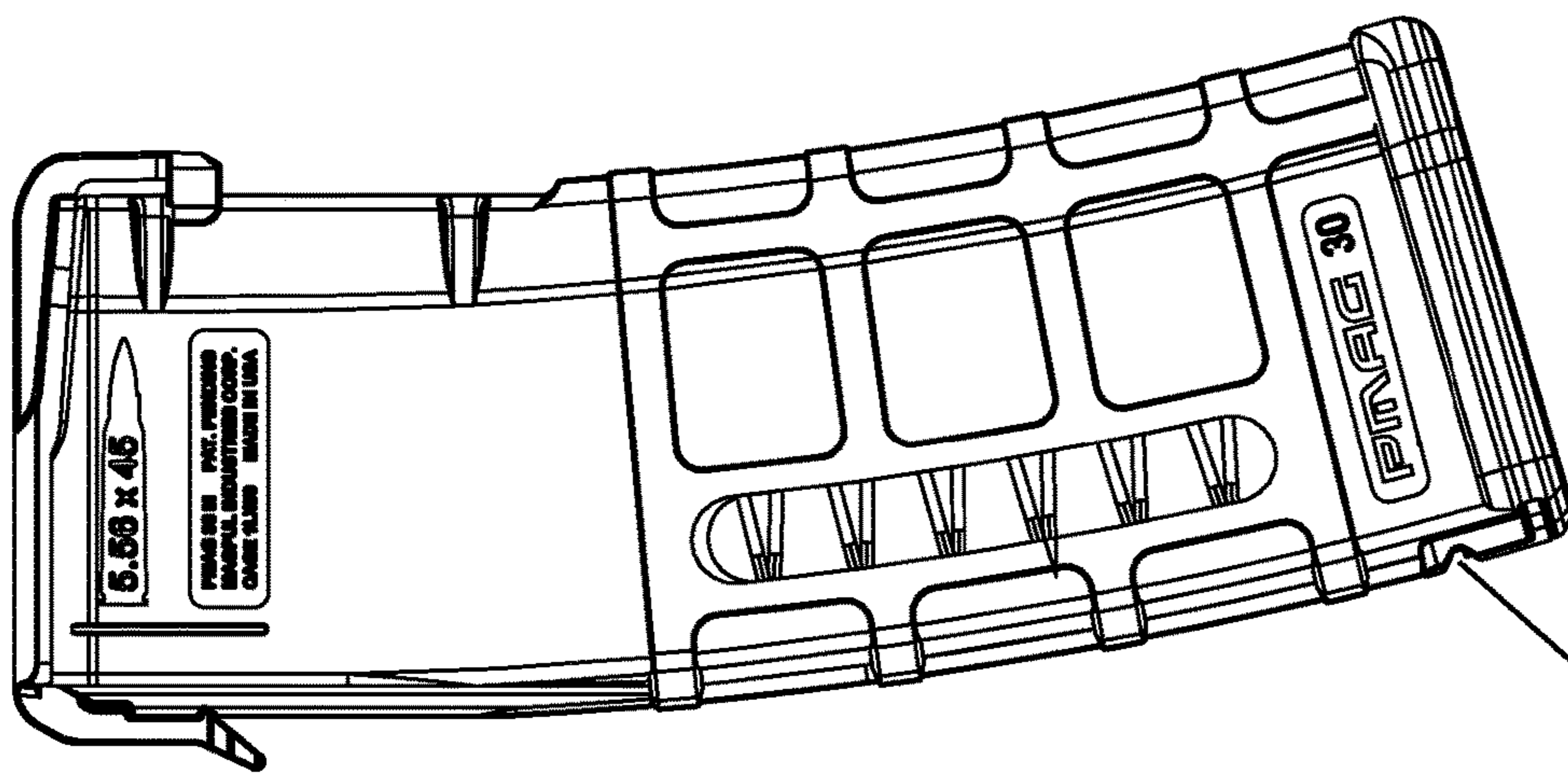

FIG. 13

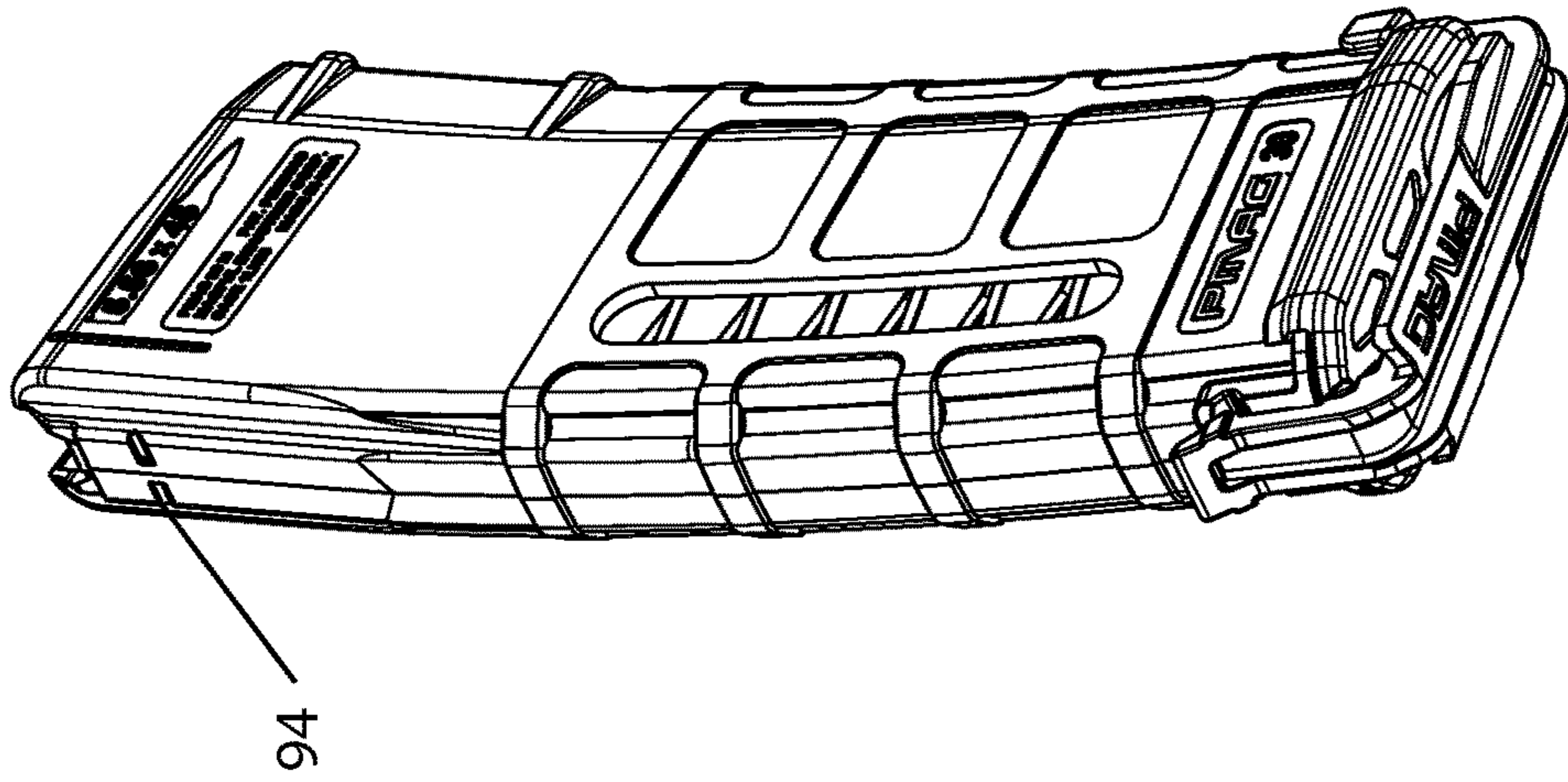

FIG. 17

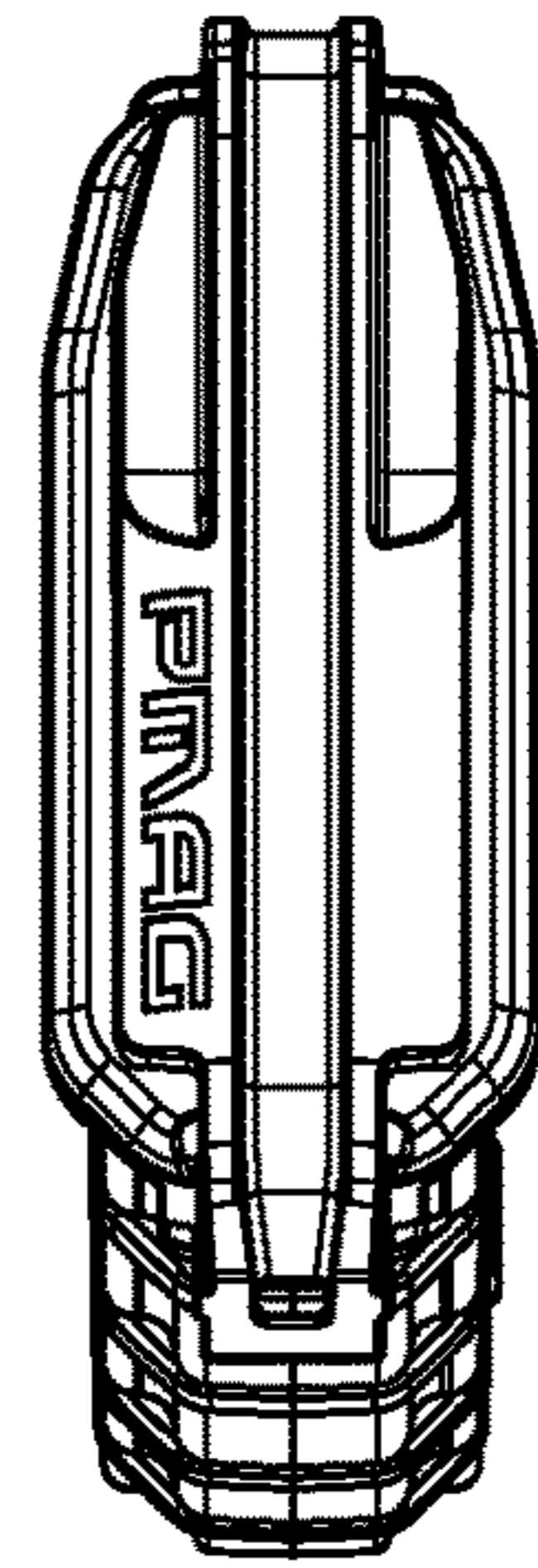

FIG. 18

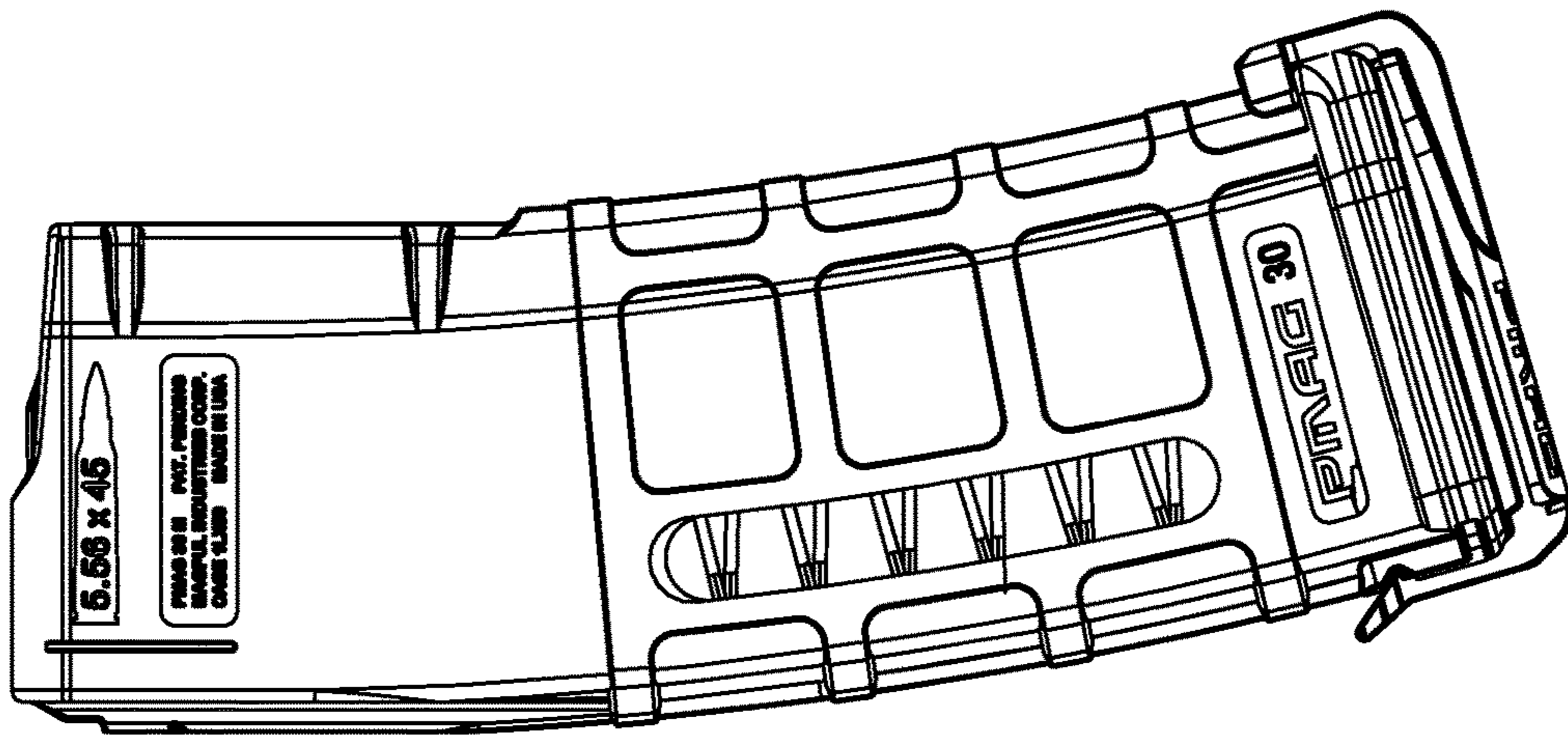

FIG. 16

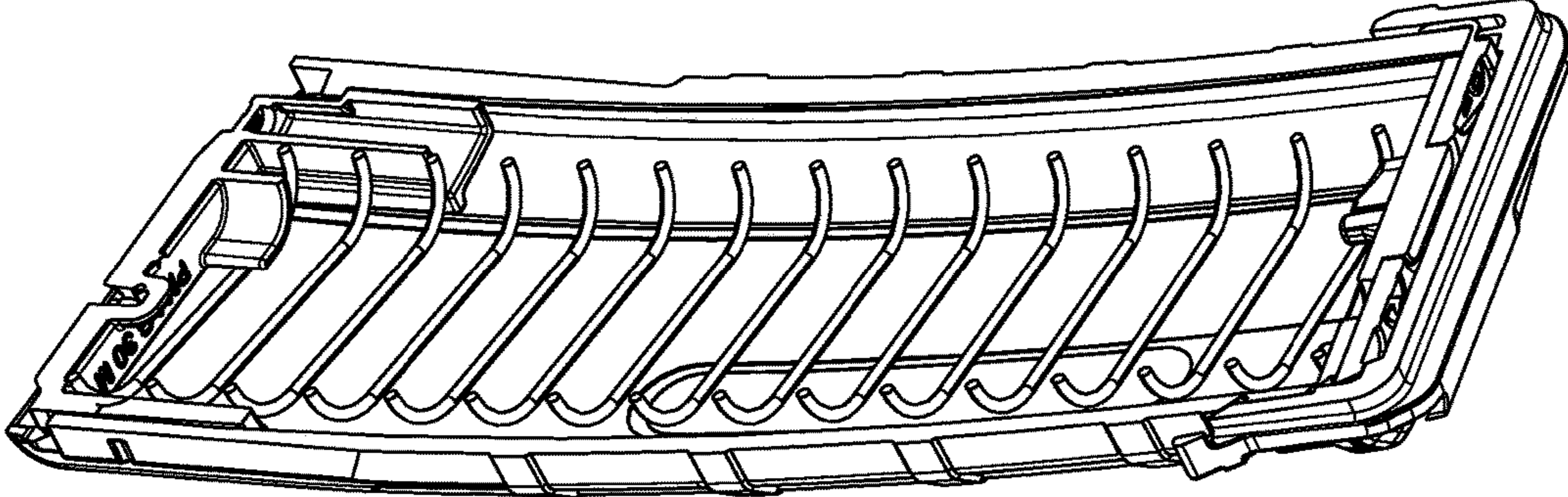

FIG. 20

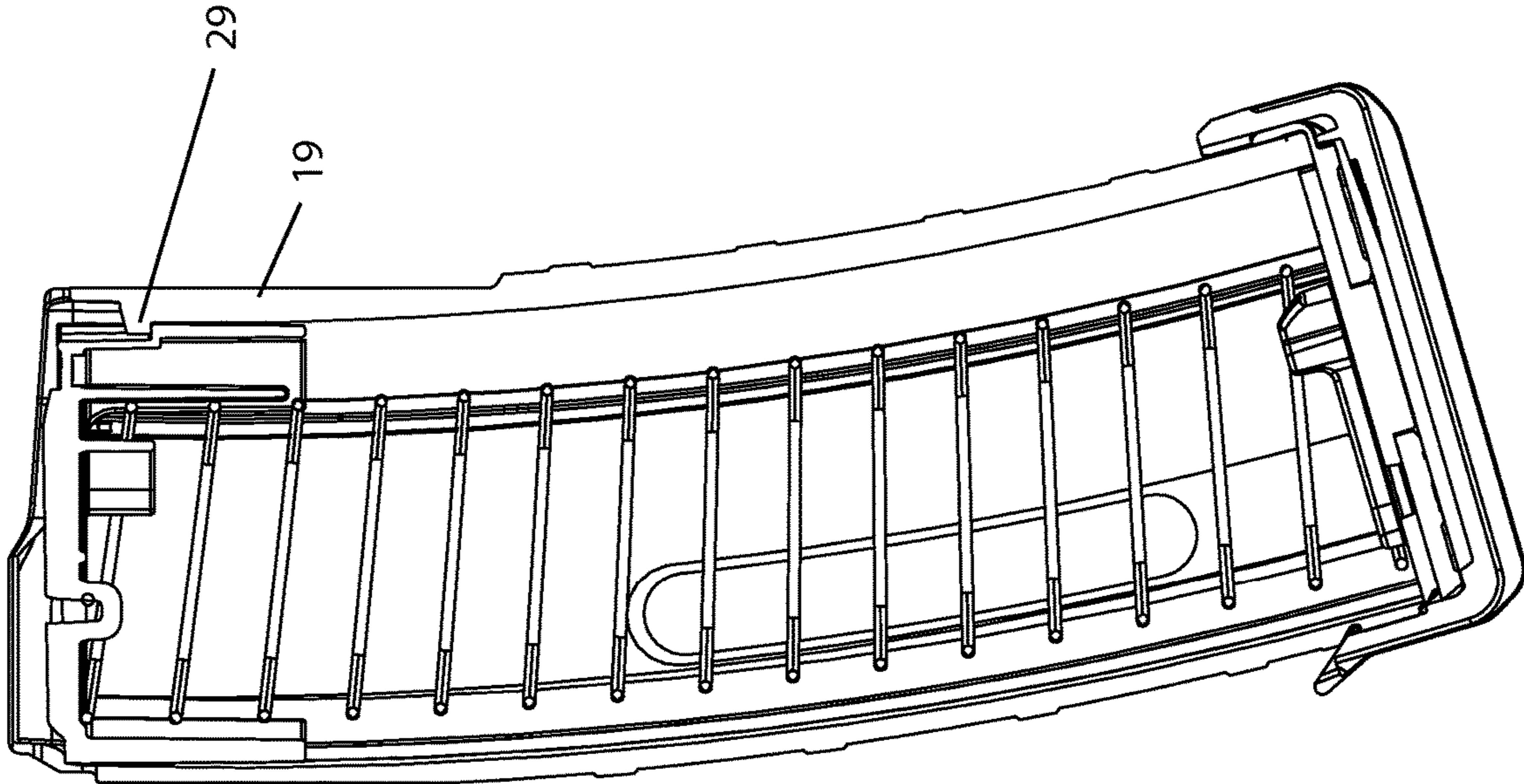

FIG. 19

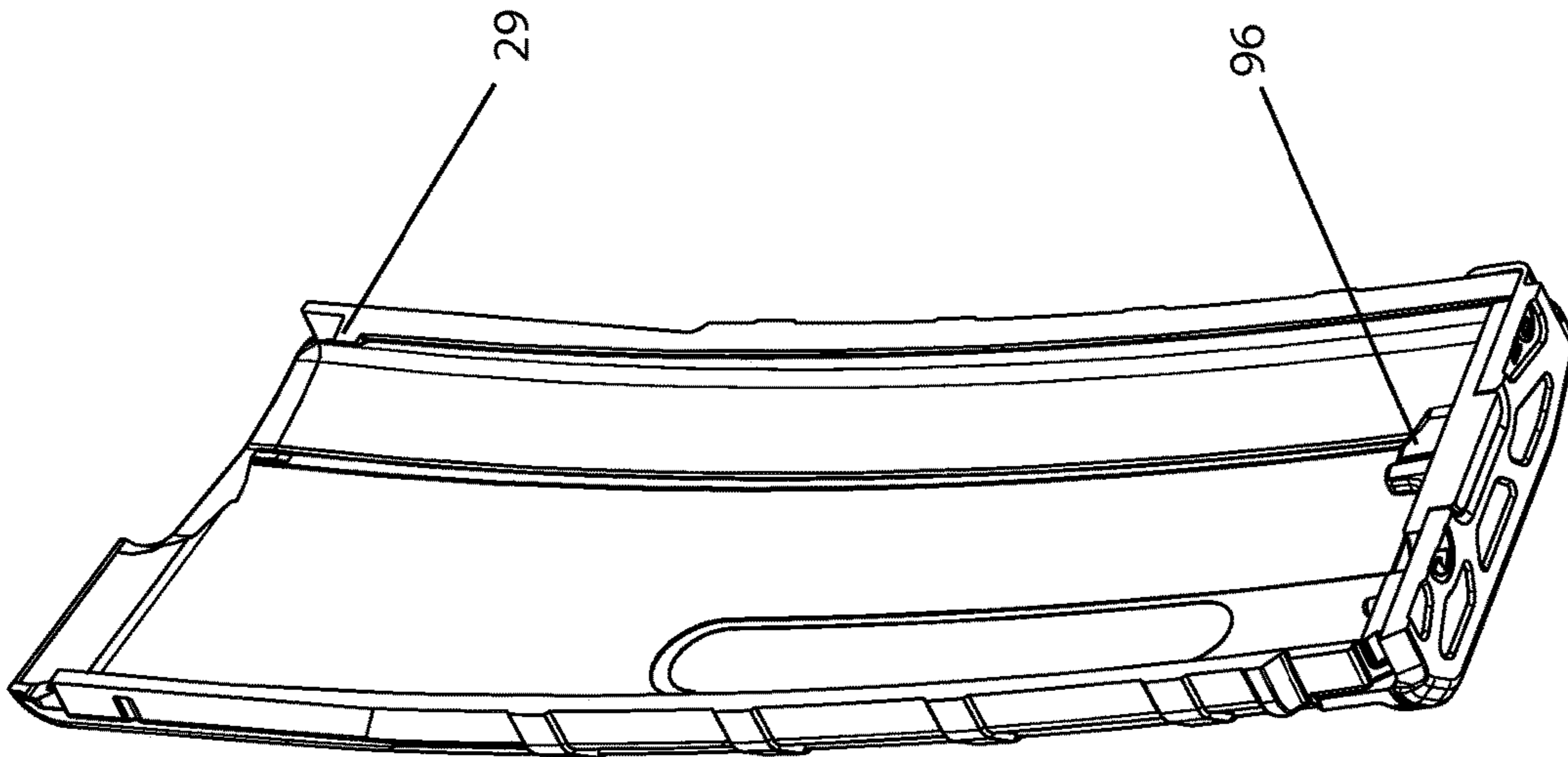

FIG. 22

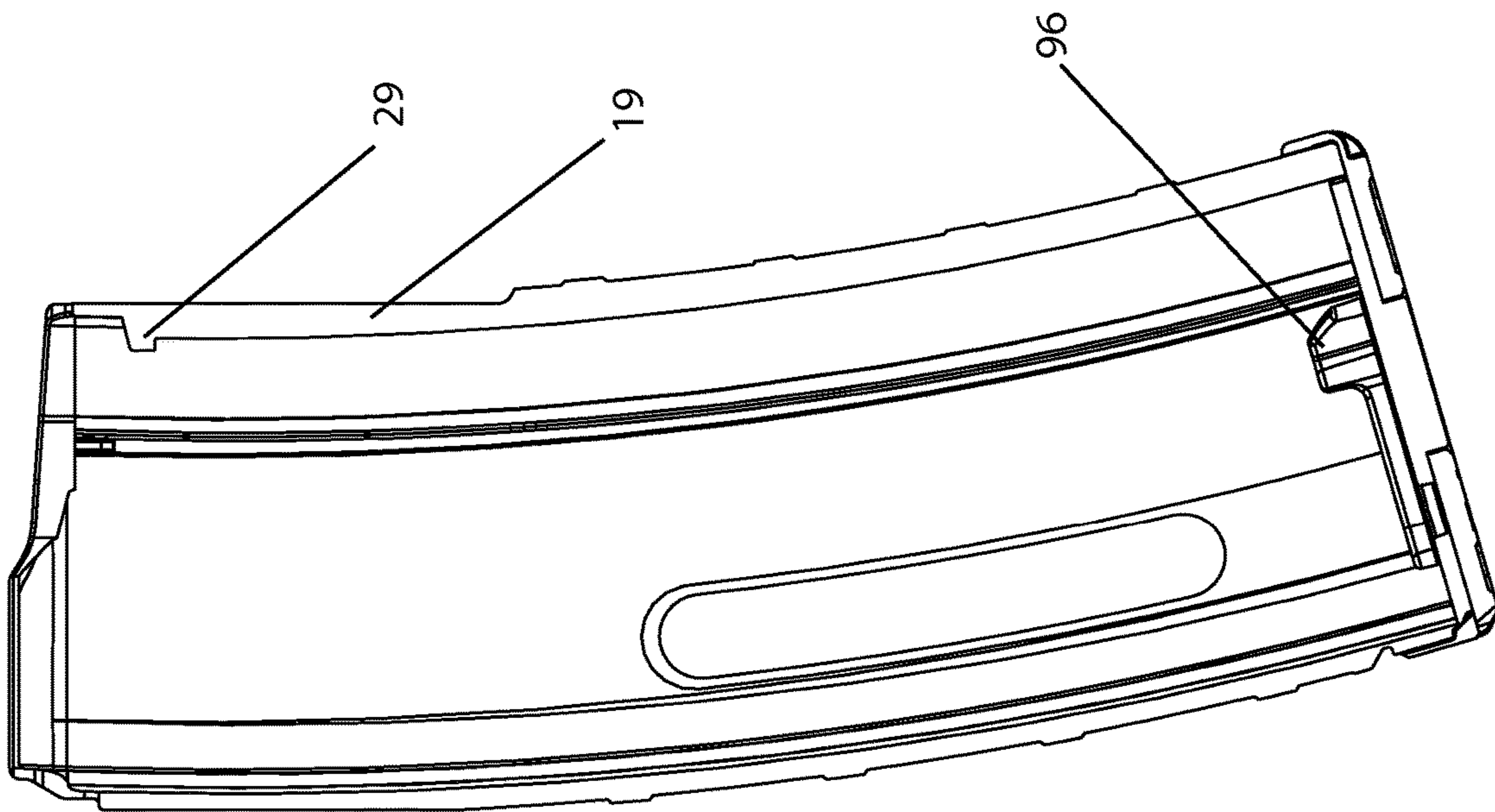

FIG. 21

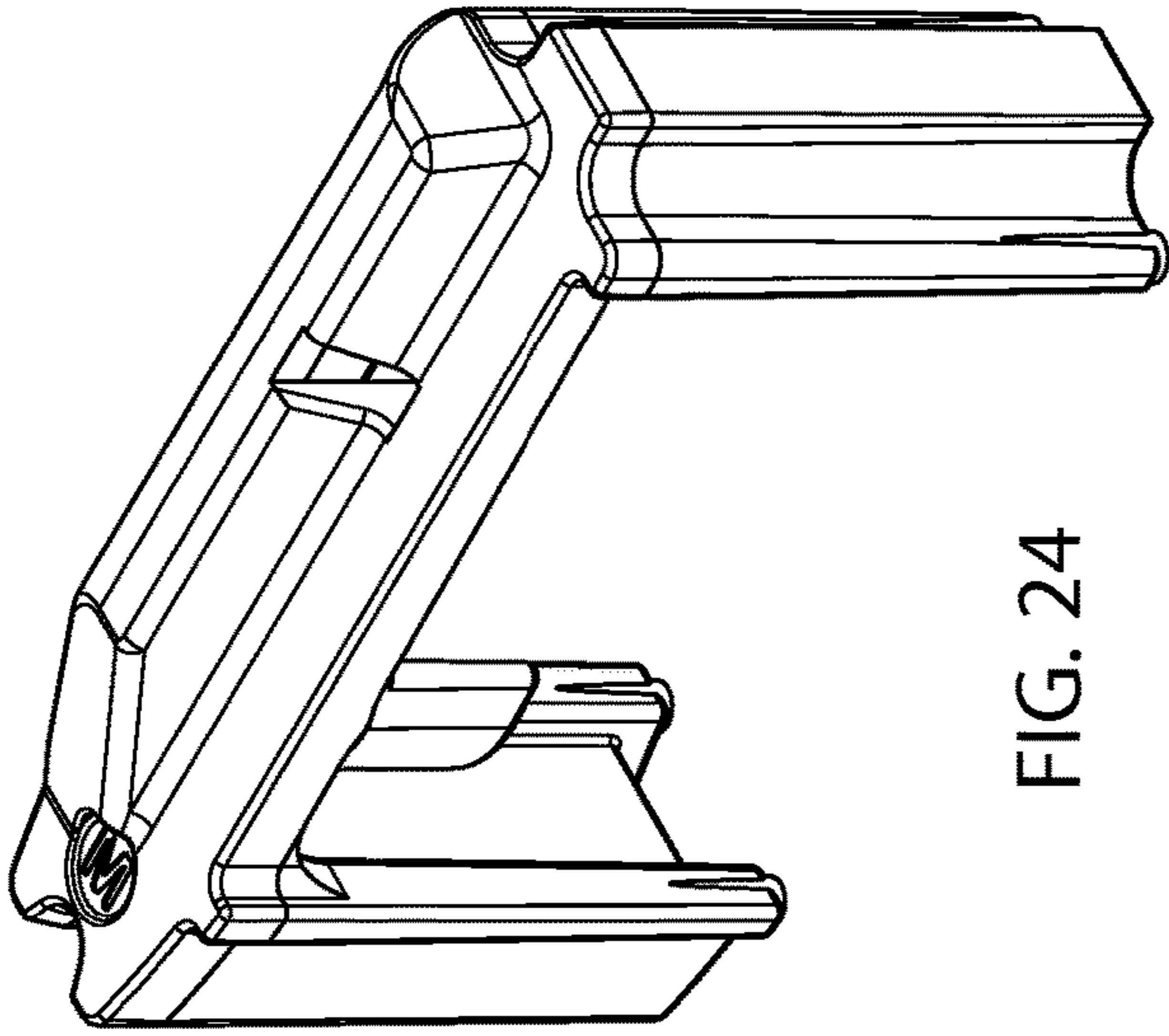

FIG. 24

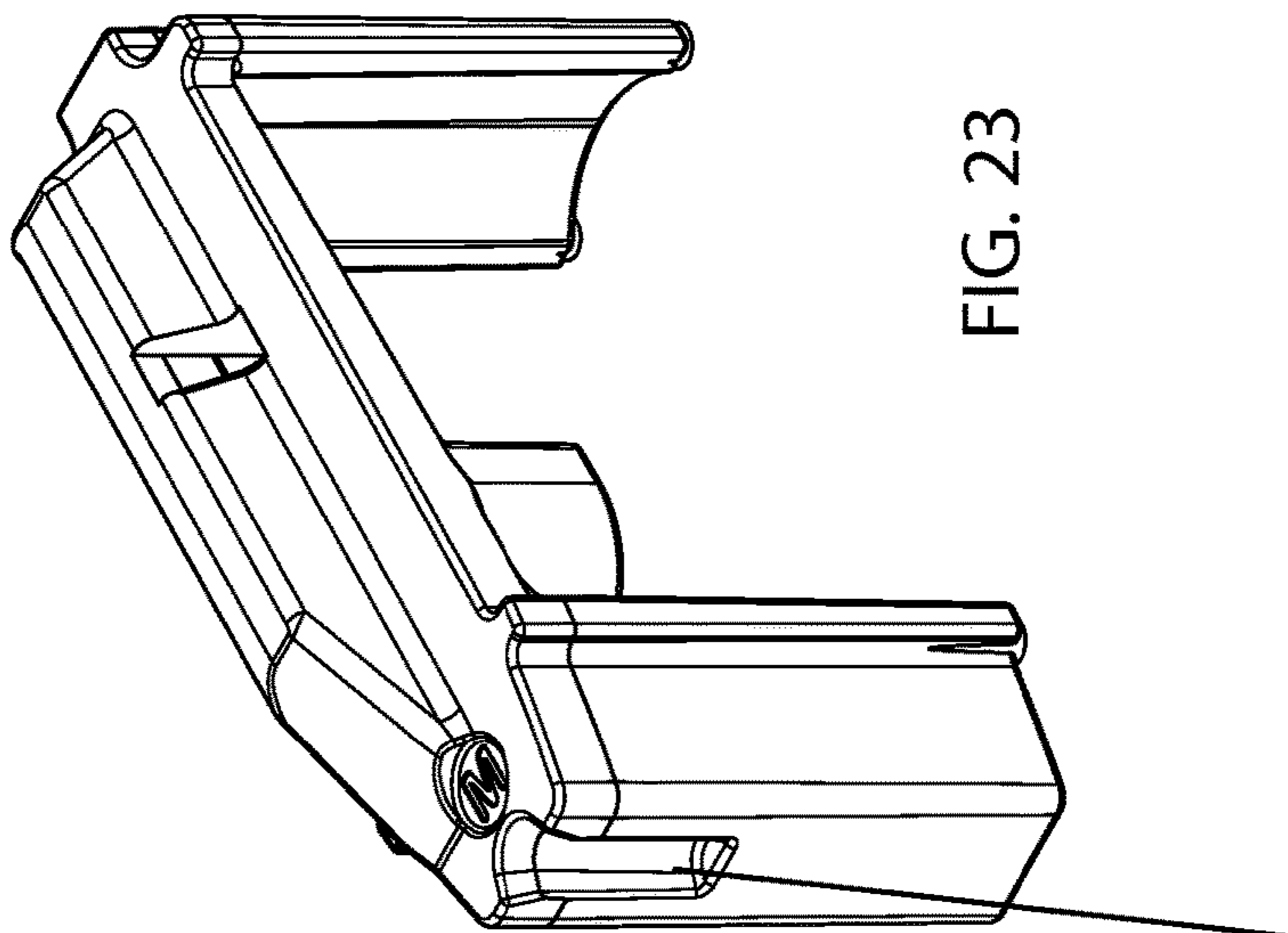

FIG. 23

90

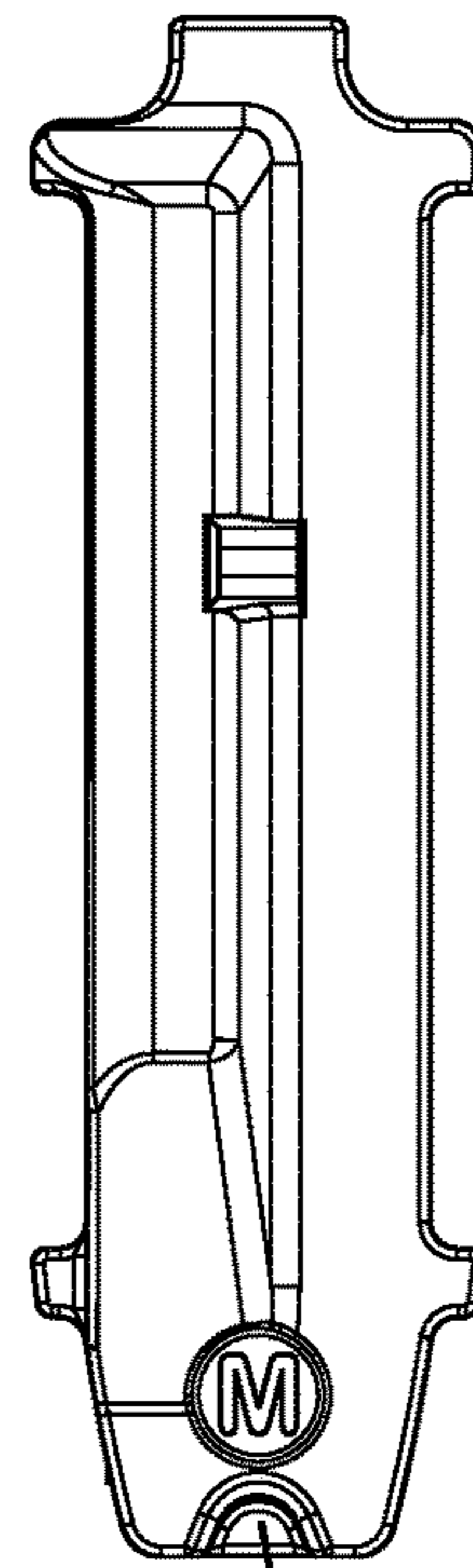

FIG. 25

90

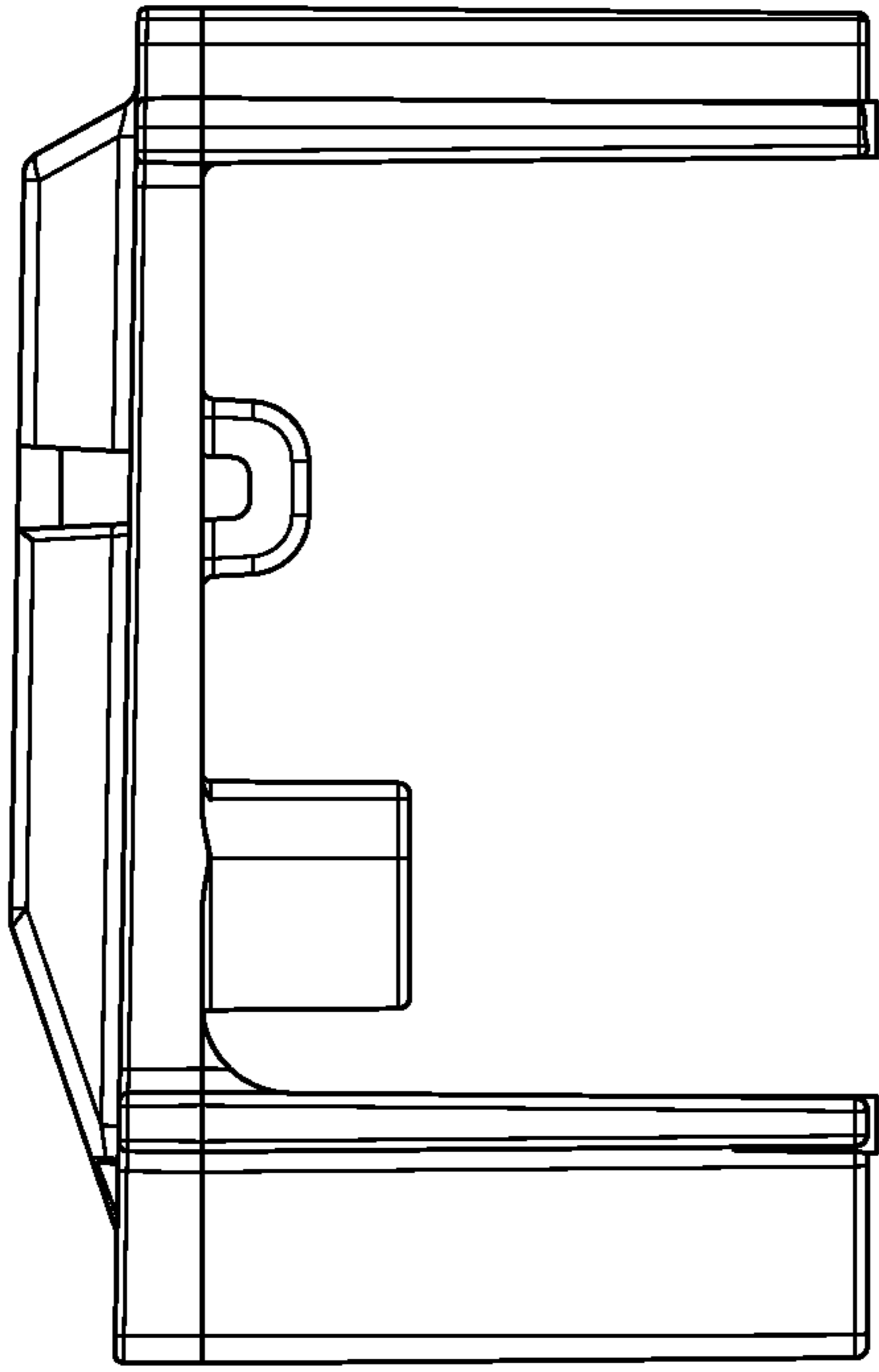

FIG. 26

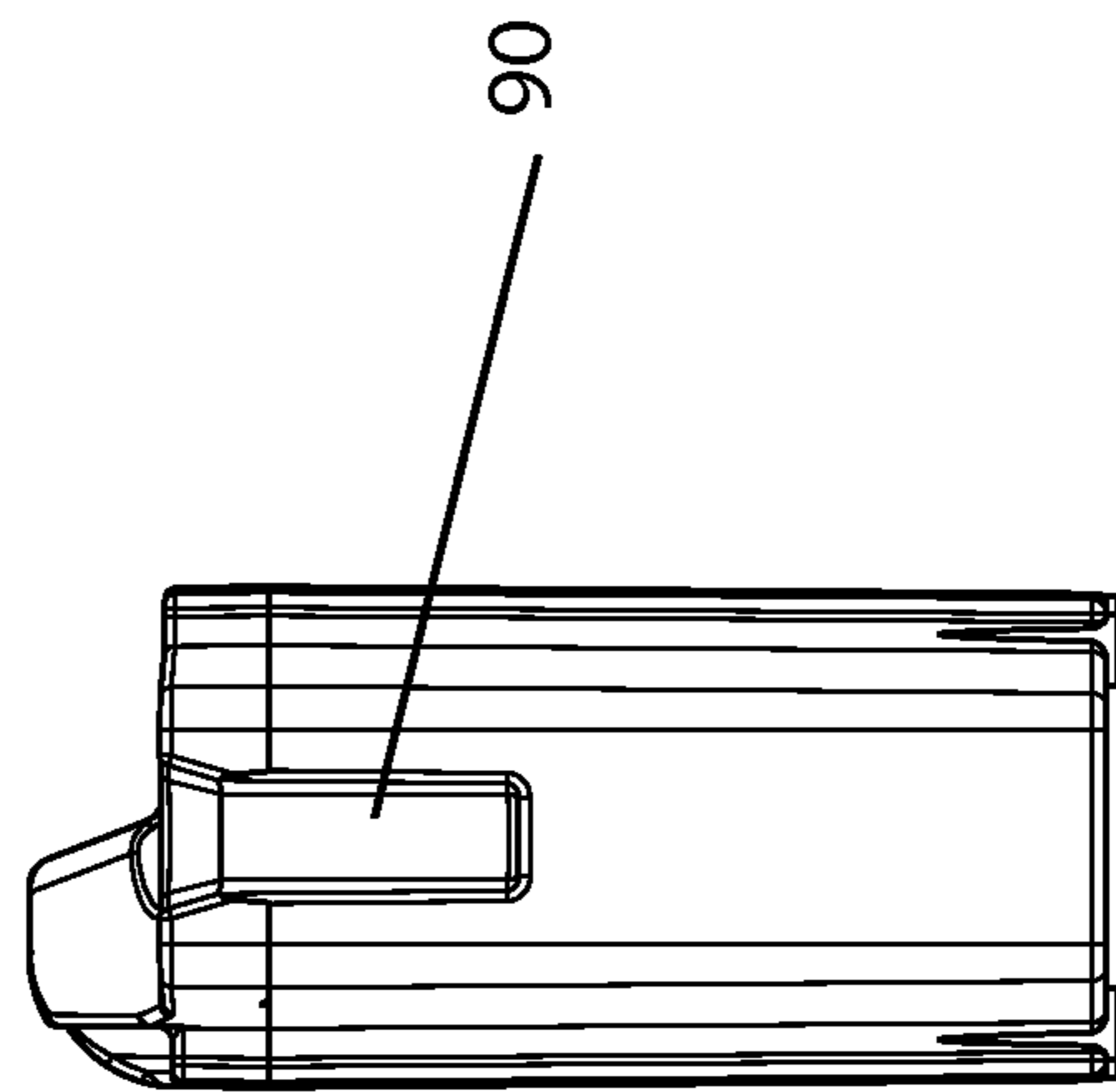

FIG. 27

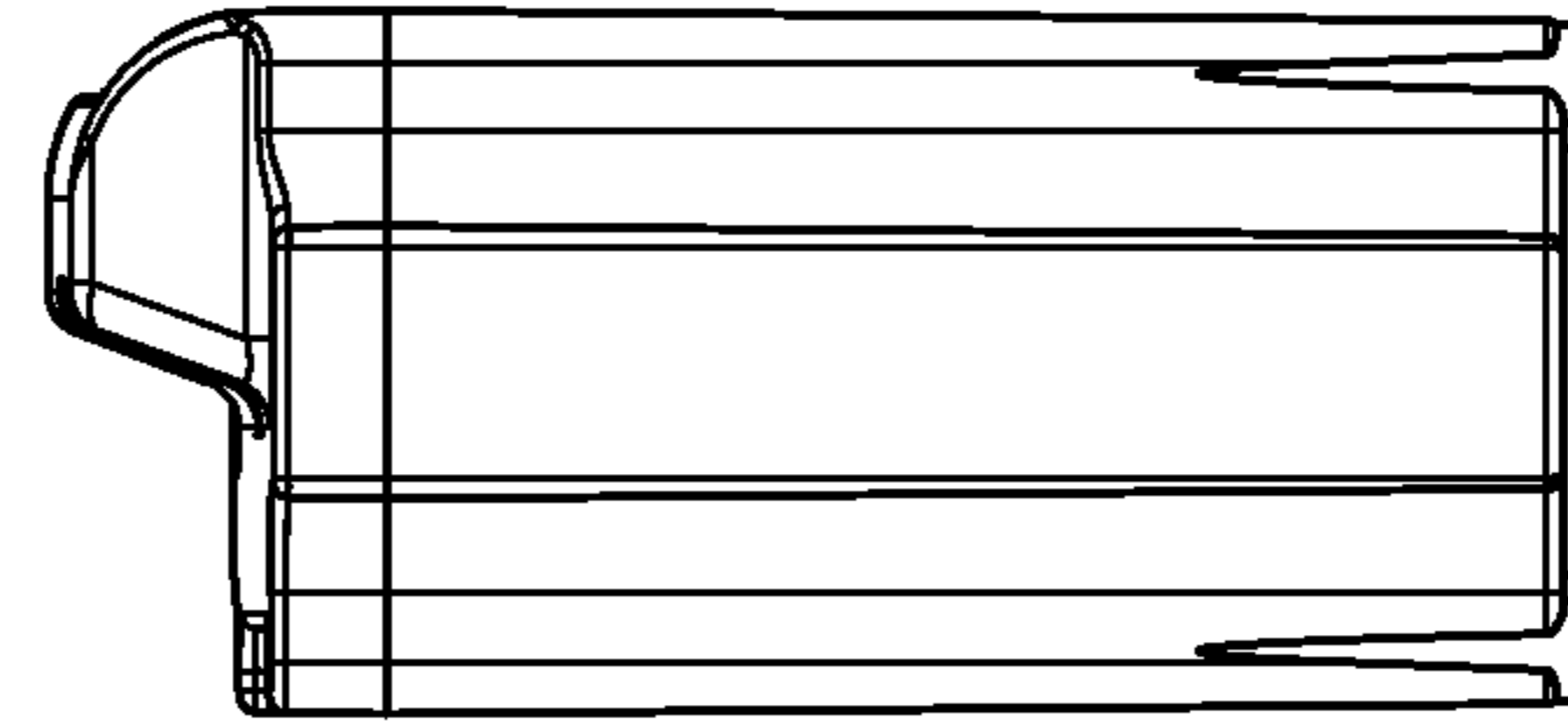

FIG. 28

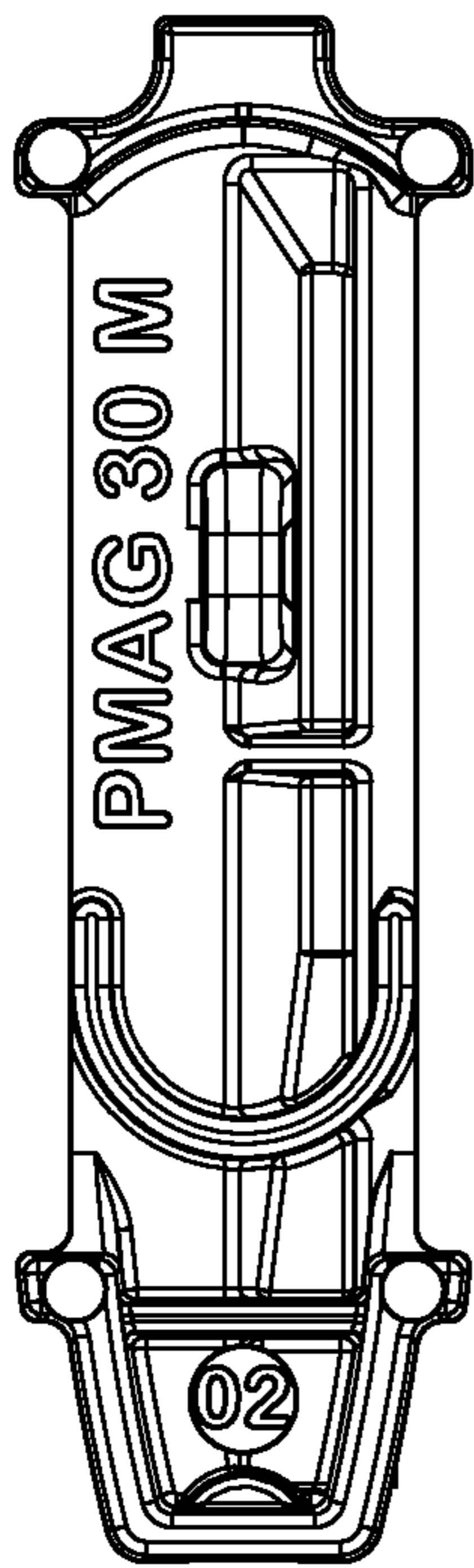

FIG. 29

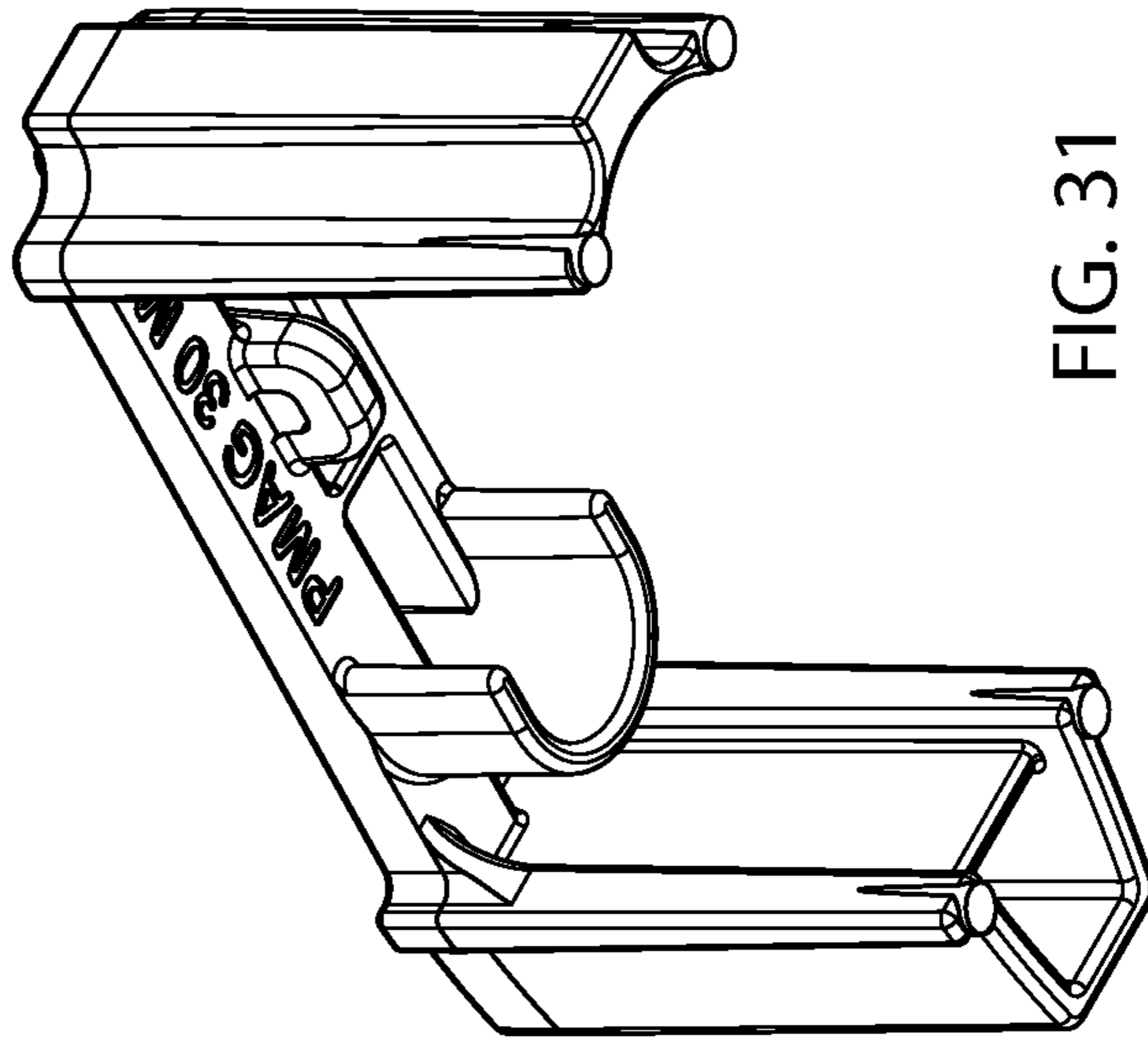

FIG. 31

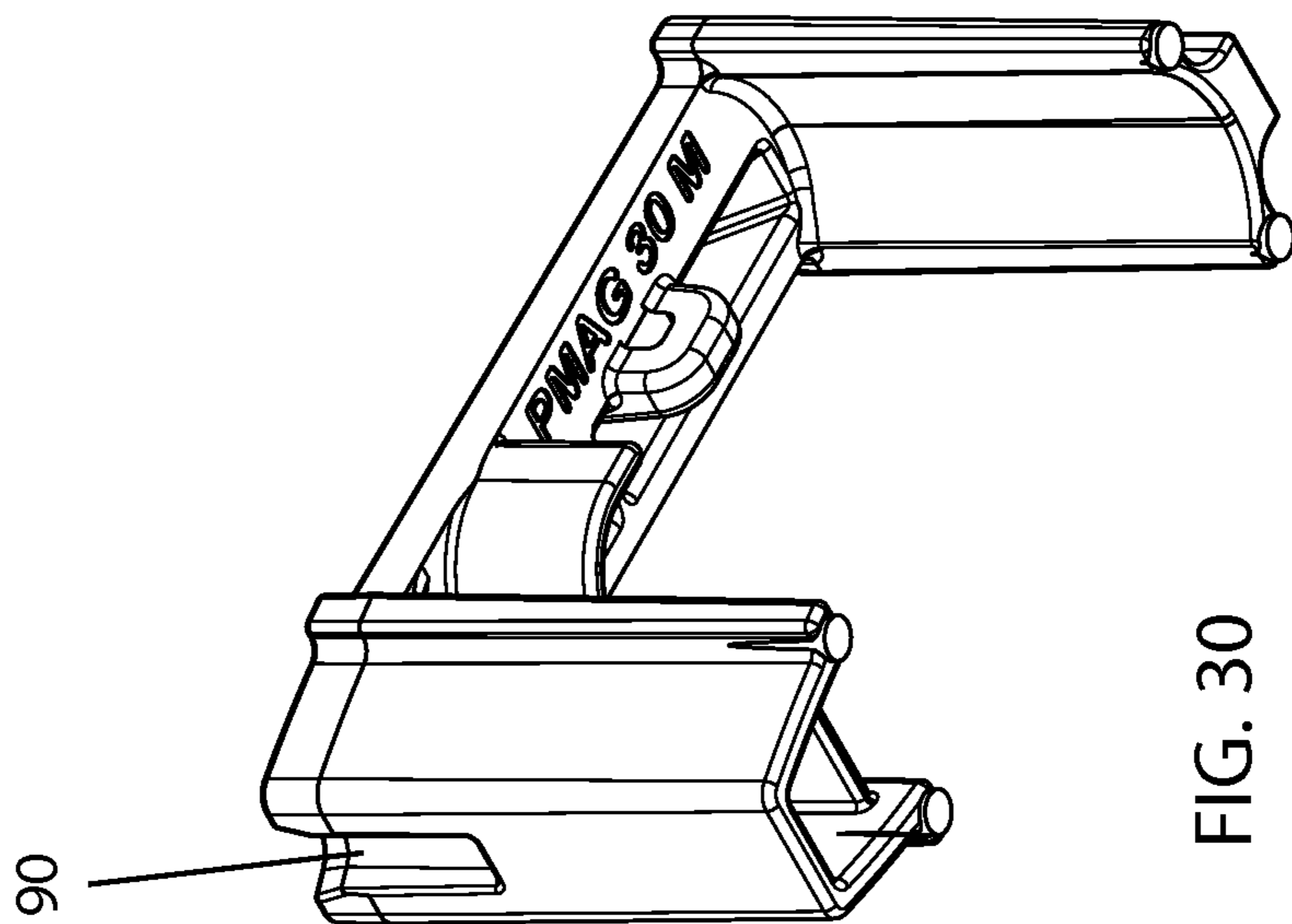

FIG. 30

AMMUNITION MAGAZINE

Matter enclosed in heavy brackets [] appears in the original patent but forms no part of this reissue specification; matter printed in italics indicates the additions made by reissue; a claim printed with strikethrough indicates that the claim was canceled, disclaimed, or held invalid by a prior post-patent action or proceeding.

CLAIM OF PRIORITY UNDER 35 U.S.C. § 120

The present Application for Patent is a *reissue of U.S. patent application Ser. No. 15/661,620 entitled "Ammunition Magazine" filed Jul. 27, 2017 and issued on Sep. 11, 2018 as U.S. Pat. No. 10,072,903, which is a Continuation of U.S. patent application Ser. No. 14/632,804 entitled "Ammunition Magazine" filed Feb. 26, 2015 and issued on Aug. 29, 2017 as U.S. Pat. No. 9,746,264, which is a Continuation of U.S. patent application Ser. No. 14/461,229 entitled "Ammunition Magazine" filed Aug. 15, 2014 and issued on Mar. 31, 2015 as U.S. Pat. No. 8,991,086, which is a Continuation-in-Part of patent application Ser. No. 14/098,467 entitled "Ammunition Magazine" filed Dec. 5, 2013 and issued on Sep. 23, 2014 as U.S. Pat. No. 8,839,543, which is a Continuation of patent application Ser. No. 13/307,431 entitled "Ammunition Magazine" filed Nov. 30, 2011 and issued on Jan. 28, 2014 as U.S. Pat. No. 8,635,796, which is a Continuation of prior filed U.S. application Ser. No. 12/354,766, filed Jan. 15, 2009 and issued on Dec. 6, 2011 as U.S. Pat. No. 8,069,601 which, in turn, is a Continuation-in-Part of prior filed U.S. application Ser. No. 11/958,274, filed on Dec. 17, 2007 issued on Mar. 22, 2011 as U.S. Pat. No. 7,908,780, which, in turn, claims priority to earlier filed U.S. Provisional Application No. 60/941,646, filed on Jun. 1, 2007. Each of these patents and applications are assigned to the assignee hereof and are hereby expressly incorporated by reference herein.*

FIELD OF THE DISCLOSURE

The present invention relates to the field of firearms and more particularly relates to an improved ammunition magazine.

BACKGROUND

Ammunition magazines are well known in the art of firearms. Their basic construction is a containment shell with two open ends. One end is deemed the "floor" of the magazine and is covered by a plate while the opposite end is the "feed" end and interfaces with the weapon. Inside the volume defined by the shell and plate is a spring and follower assembly. When ammunition is loaded into the magazine, the ammunition pushes the follower down towards the floor and thereby compresses the spring. In use, when one cartridge of ammunition is expended, the compressed spring releases and pushes the follower and associated ammunition upwards toward the feed end and the next round of ammunition is thereby readied.

Prior magazines have been manufactured in many different configurations and of different materials. Perhaps the best known in the U.S. are the AK-47 and the USGI AR15/M16 magazines. These magazines function similarly, though they are made with slight variations to interface with their host system. Of notable difference is that the AK-47 magazine has a relatively constant curvature while the

AR15/M16 magazine has a less curved lower region that gradually resolves to a more linear function towards the feed end. Both use the same type of internal system. Of particular note with both, and all follower magazine systems, is that the system works well only as the follower smoothly and levelly travels the inside of the magazine. As the follower must move, there is room for the follower in all the known prior art magazines to move axially, or "wobble" and possibly jam. This is notorious in the AR15/M16 magazine style as the geometry of the magazine is inherently not uniform.

The present invention is a polymer magazine with angularly shaped guide rails to interface with the internal follower, thereby restricting axial motion of the follower. The magazine also features a load indicator and a two-piece floor plate locking system. The present invention represents a departure from the prior art in that the magazine of the present invention allows for more stable and level motion of the follower while the magazine is loaded or unloaded.

SUMMARY OF THE DISCLOSURE

In view of the foregoing disadvantages inherent in the known types of ammunition magazines, this invention provides an improved magazine. As such, the present invention's general purpose is to provide a new and improved magazine that is backwards compatible with known weapon platforms and presents a more stable follower and follower path.

To accomplish these objectives, the improved ammunition magazine comprises a plurality of lateral angularly shaped guide rails within the magazine shell and a follower that is configured to abut them. By interfacing with more internal structure, all non-advantageous linear and axial motion is inhibited and the follower is then more stable in its progress. The magazine also features a polymer construction and an ammunition load indicator system. The magazine also features a cover for storage.

The more important features of the invention have thus been outlined in order that the more detailed description that follows may be better understood and in order that the present contribution to the art may better be appreciated. Additional features of the invention will be described hereinafter and will form the subject matter of the claims that follow.

Many objects of this invention will appear from the following description and appended claims, reference being made to the accompanying drawings forming a part of this specification wherein like reference characters designate corresponding parts in the several views.

Before explaining at least one embodiment of the invention in detail, it is to be understood that the invention is not limited in its application to the details of construction and the arrangements of the components set forth in the following description or illustrated in the drawings. The invention is capable of other embodiments and of being practiced and carried out in various ways. Also it is to be understood that the phraseology and terminology employed herein are for the purpose of description and should not be regarded as limiting.

As such, those skilled in the art will appreciate that the conception, upon which this disclosure is based, may readily be utilized as a basis for the designing of other structures, methods and systems for carrying out the several purposes of the present invention. It is important, therefore, that the

claims be regarded as including such equivalent constructions insofar as they do not depart from the spirit and scope of the present invention.

BRIEF DESCRIPTION OF THE DRAWINGS

FIG. 1 is an exploded view of the magazine according to the present invention.

FIG. 2 is a perspective view of the assembled magazine according to the present invention.

FIG. 3 is a side plan view of the magazine of FIG. 2.

FIG. 4 is a perspective view of the magazine according to the present invention, without the impact cover.

FIG. 5 is a hind plan view of the magazine of FIG. 4.

FIG. 6 is a sectional view of the magazine in FIG. 5, taken along line 6-6.

FIG. 6a is a perspective view of the floor and lock plates according to the present invention.

FIG. 6b is a side plan view of the floor and lock plates of FIG. 6a.

FIG. 6c is an alternative perspective view of the floor and lock plates of FIG. 6a.

FIG. 7 is a bottom plan view of the magazine body, according to the present invention.

FIG. 8 is a cross-section of the magazine body of FIG. 7, taken along line 8-8 and re-orientated with the bottom down.

FIG. 9 is a perspective view of the follower according to the present invention.

FIG. 9a is a side plan view of the follower of FIG. 9.

FIG. 9b is a front plan view of the follower of FIG. 9.

FIG. 9c is a rear plan view of the follower of FIG. 9.

FIG. 9d is a bottom plan view of the follower of FIG. 9.

FIG. 9e is a sectional view of the follower of FIG. 9d, taken along line 9e-9e.

FIG. 10 is a perspective view of the impact cover according to the present invention.

FIG. 10a is a side plan view of the impact cover of FIG. 10.

FIG. 10b is a front plan view of the impact cover of FIG. 10.

FIG. 10c is a rear plan view of the impact cover of FIG. 10.

FIG. 10d is a bottom plan view of the impact cover of FIG. 10.

FIG. 10e is a sectional view of the impact cover of FIG. 10d, taken along line 10e-10e.

FIGS. 11a-11c are successive plan views showing use of the impact cover as a magazine unloading tool.

FIGS. 12a-12c are successive plan views showing use of the impact cover to disassemble the magazine.

FIG. 13 is a side plan view of an alternate embodiment of the magazine according to the present invention.

FIG. 14 is a rear perspective view of the magazine of FIG. 13.

FIG. 15 is a bottom plan view of the magazine of FIG. 13.

FIG. 16 is a side plan view of the magazine of FIG. 13, with the impact cover in a stowed position on the magazine.

FIG. 17 is a rear perspective view of the magazine of FIG. 16.

FIG. 18 is a bottom plan view of the magazine of FIG. 16.

FIG. 19 is a sectional view of the magazine of FIG. 16.

FIG. 20 is a sectional view of the magazine of FIG. 17.

FIG. 21 is a sectional view of the magazine's external components, along the same section line as FIG. 19.

FIG. 22 is a sectional view of the magazine's external components, along the same section line as FIG. 20.

FIG. 23 is a left, front, top perspective view of a follower for the alternative magazine embodiment depicted in FIG. 13.

FIG. 24 is a left, rear, top perspective view of the follower of FIG. 23.

FIG. 25 is a top plan view of the follower of FIG. 23.

FIG. 26 is a left plan view of the follower of FIG. 23.

FIG. 27 is a front plan view of the follower of FIG. 23.

FIG. 28 is a rear plan view of the follower of FIG. 23.

FIG. 29 is a bottom plan view of the follower of FIG. 23.

FIG. 30 is a left, front, bottom perspective view of the follower of FIG. 23.

FIG. 31 is a left, rear, bottom perspective view of the follower of FIG. 23.

DETAILED DESCRIPTION

With reference now to the drawings, the preferred embodiment of the ammunition magazine is herein described. It should be noted that the articles "a", "an" and "the", as used in this specification, include plural referents unless the content clearly dictates otherwise.

With reference to FIG. 1, the magazine 1 generally comprises a body 10 having a floor end 13 and a feed end 17. The magazine 1, can have fore and aft sides and two lateral sides longer than the fore and aft sides. Feed lips 21 are provided at the feed end 17 to interface with a weapon and to guide cartridges into the firing chamber of said weapon. The floor end is capped with a floor plate 20 which is secured by a lock plate 25. A spring 35 rests against the lock plate 25, centered by walls 24 (see FIG. 6a), and floor plate 20 combination and provides tension to bias the follower 30 and the floor plate 20 so that the follower 30 will progress up the magazine body 10 as ammunition is used. Floor plate 20 slides over a rim 23 of the floor end 13, using a ledge to interface with the rim, and simultaneously over the lock plate 25. The floor plate 20 and lock plate 25 interface together with a tab 26 on the lock plate resting within a slot 27 of the floor plate (shown in FIGS. 6-6c), so, with the floor plate 20 holding the magazine 1 and the lock plate 25 holding the floor plate 20 laterally, as it is forced against the floor plate 20 by the spring, the floor plate 20 does not slide off the magazine 1. A protective impact cover 40 is also provided for use during storage. Magazine 1 also features two indicator windows 15 to view the spring. An indicator, which could be as simple as a colored dot or a dab of properly placed paint, is positioned on the spring and is viewable through the windows when the magazine 1 is assembled. Ideally, the windows 15 are positioned on either side of the magazine body 10 and are close enough to the floor end so that they are not obscured when the magazine 1 is inserted in a weapon's magazine well. FIGS. 2-4 provide views of the magazine 1 assembled, FIG. 4 without the impact cover 40.

Inside the body 10, along the fore side of the magazine 1, is a ridge 19, shown in FIGS. 6, 7, and 8. The ridge serves three purposes. The first purpose is to provide additional stability and strength to the magazine body 10. The second purpose is to divide tips of cartridges, left from right, in their off-set stacking in the magazine. The third purpose is to provide an additional interface with the follower 30 to prevent forward linear and axial tilt. In order to accommodate stripper clips, the ridge 19 may terminate at a point significantly below the feed lips, about 0.5 inches for a 0.223 Remington caliber magazine, as shown in FIGS. 19-22. The factors that govern this dimension relate to cartridge size, stripper clip design and geometry, the method used to move

the cartridges from the stripper clip to the magazine, and the number of rounds on the stripper clip, among other factors. The body also has two lateral guide rails 31 extending through the body 10. The guide rails 31 are flattened in front and angular towards the rear so as to present a more solid surface for the follower to abut and to guide cartridges as they travel through the magazine body 10. So as to not interfere with feeding of cartridges into the weapon, the guide rails 31 should terminate 31a at approximately a cartridge's diameter of the feed end 17 of the magazine body (as defined by the level where the rib 19 terminates with tab 29), or about 1/4 inch for a 0.223 Remington magazine or 5/16 of an inch for a .308 Winchester caliber magazine. This is, however, only for certain embodiments, as the guide rails 31 can extend the entire length of the magazine body 10 and the magazine will still be functional.

As shown in FIGS. 9-9e, the follower 30 has two tines, a forward tine 33 and hind tine 37. Both tines are elongated and extending from platform 34. The forward tine 33 presses against the ridge 19 and prevents axial movement, particularly those movements caused by the simple act of firing the weapon, which would push the rear of the ammunition (and the follower 30) down. The hind tine 37 fits into trough 11 (FIG. 7) to prevent lateral movement. The extension of the tines greatly inhibits axial and lateral movement as the extension increases contact with the magazine body and provides more counter-torque when forces would cause such movement. The follower also has two lateral arms 36 that fit alongside of the guide rails 31 to further inhibit rotation. The follower 30 interfaces with spring 35 by attachment of the spring 35 to loop 38 and retention of the spring 35 by retaining wall 32. In some embodiments, the hind tine 37 can be excluded and the interaction of the lateral arms 36 and the guide rails 31 can be a primary inhibitor of rotation of the follower. In other embodiments, the one or more tines 33, 37 can be split via a vertical separation or gap (G).

At the top of ridge 19 is a slight tab 29 (FIGS. 6 and 8) that protrudes towards the interior of the magazine 1. Tab 29 serves as a block to prevent the follower 30 from exiting the feed end 17 of the magazine 1. It interfaces with a detent 39 provided in the follower 30 (FIGS. 9, 9b, and 9e). In the embodiment shown in FIGS. 19-22, the tab 29 is, of course, lower in relation to the feed lips. The follower 30 then, as shown in FIGS. 23-31 has a chamfered groove 90 so as to allow the follower 30 to still be blocked, but in a manner that allows it to fully rise in relation to the magazine. The groove 90 also allows further interface to reduce disadvantageous tilt in the follower. In an embodiment, the lock plate 25 may also feature a ridge 96 to interface with the bottom of the follower 30 when the magazine is fully loaded, so as to support the follower 30 and round stack and reduce spring fatigue, as shown in FIGS. 19-22.

In an embodiment, the magazine body is comprised of a reinforced thermoplastic polymer selected to resist damage from use (e.g., the ejection of a magazine which causes the magazine to impact a hard surface, which may occur during a speed reload). However, other polymers may be used and the magazines may be made in any color or opacity (which can reduce or eliminate the need for a magazine level indicator). Some polymers may be used without reinforcement. Various reinforcement materials, such as glass, carbon (e.g., carbon fiber or carbon nanotubes), minerals, or metals (e.g., steel, titanium, aluminum, etc.) may also be used to reinforce the magazine. Likewise, the magazine body may be made of other materials having suitable strength and durability, such as titanium, ceramics, laminates, amorphous metals, etc. The follower is preferred to be made of poly-

oxymethylene, or acetal resin, available commercially from DuPont under the trade name DELRIN, though other materials are suitable, just not preferred.

The magazine 1 is structured to increase its structural integrity. To that end, fore ridge 19 provides added durability to the magazine. Protective cover 40 also provides reinforcement during storage, as pressures from the stored ammunition and spring 35 would normally force the feed lips 21 of the magazine 1 apart. Protective cover 40, shown in FIGS. 10-10e, interfaces with geometry, namely notch 44 and hinge base 48, on the magazine body 10 with latch 43 and cover hinge 47 (FIGS. 2, 3 and 4), and forces the ammunition downward with an underside spacer 45, thereby redirecting and distributing the forces that would normally be applied to the feed lips 21 in a more advantageous manner. Geometry 92 may be added to the magazine to allow the cover to fasten on the bottom of the magazine for storage (FIGS. 13-18). A double notch 94 may be utilized (FIG. 17) as this geometry can benefit the molding process.

The cover 40 also serves as a magazine tool as the cover latch 43 will fit between the feed lips 21 so as to push rounds of ammunition 50 out of the magazine 1 (FIGS. 11a-11c). It also has a specialized gauge 49 to determine if the feed lips 21 have either splayed or compressed in a manner to prevent operability of the magazine with the weapon (FIGS. 10-10e). Gauge 49 is a flared area, specially sized depending upon the size of ammunition, slightly above latch 43. The operable magazine 1 will accommodate the latch 43 between the feed lips 21, but not the gauge. If the latch 43 is unable to fit between feed lips 21, then the feed lips 21 have compressed in some manner, perhaps due to impact or compression damage, and the magazine 1 is then not fit for use. If the gauge 49 is able to fit between feed lips 21, then the feed lips 21 have splayed, perhaps due to long term storage without the impact cover 40, and the magazine 1 is not fit for use. Measurements of the gauge and latch widths will be dependent upon the type of ammunition used. Likewise, this magazine 1 is capable of being used in multiple weapon platforms, each with its own tolerances. The widths of the latch 43 and gauge 49 would be dependent upon those tolerances and different weapon platforms may be accommodated by merely fashioning a different version of the impact cover 40 for that platform, without changing the magazine as a whole. Impact cover 40 may also be used to depress the locking plate tab 26 so as to remove the floor plate 20 (FIGS. 12a-12c).

It should also be noted that magazine body 10 presents a constant internal curve, with slight straightening near the interior rear face of the feed lips only to allow interface with a weapon. As such, the follower 30 and associated ammunition travel more smoothly through the magazine body 10 with lessened round stack variation.

Although the present invention has been described with reference to preferred embodiments, numerous modifications and variations can be made and still the result will come within the scope of the invention. No limitation with respect to the specific embodiments disclosed herein is intended or should be inferred.

What is claimed is:

1. An ammunition magazine comprising:
 - a casing with fore and aft sides and two longer lateral sides longer than the fore and aft sides and first and second open ends, the casing further comprising a ridge, centrally located on an interior side of the fore side, guide rails running along insides of the longer lateral sides, the casing further comprising a [stop tab projecting internally from a front of the casing] con-

7

stant internal curve initiating at or near the second open end and continuing through a majority of the casing of the magazine; and

a follower residing within the casing, said follower further comprising a follower platform with one to four tines, one of the one to four tines being at a fore position that extends generally perpendicularly from the follower platform, the guide rails contacting the follower to act as a guide for the follower, a groove serving as a detent situated in the follower platform to interface with the stop tab].

2. The ammunition magazine of claim 1, wherein the [casing further comprises a] constant internal curve [initiating] *initiates* at the second open end [and continuing through a majority of the casing of the magazine].

3. The ammunition magazine of claim 2, wherein one of the one to four tines is arranged at an aft position of the follower platform that extends generally perpendicularly from the follower platform.

4. The ammunition magazine of claim 2, wherein [the casing further comprises a ridge, centrally located on an interior side of the fore side, wherein] a front face of one of the one to four tines presses against the ridge.

5. The ammunition magazine of claim 1, wherein [the casing further comprises a ridge, centrally located on an interior side of the fore side, wherein] a front face of one of the one to four tines presses against the ridge.

6. The ammunition magazine of claim 1, wherein one of the one to four tines is arranged at an aft position of the follower platform that extends generally perpendicularly from the follower platform.

7. The ammunition magazine of claim [1] 6, wherein [the casing further comprises a ridge, centrally located on an interior side of the fore side, wherein] a front face of *another* one of the one to four tines presses against the ridge.

8. The ammunition magazine of claim 1, wherein one or more of the one to four tines is split into two regions via a vertical gap arranged at a center of the one or more tines.

9. An ammunition magazine comprising:

a casing with fore and aft sides and two longer lateral sides longer than the fore and aft sides and first and second open ends, *the casing further comprising a ridge, centrally located on an interior side of the fore side*, the casing further comprising guide rails running along insides of the longer lateral sides, the casing further comprising a constant internal curve initiating at the second open end and continuing through a majority

8

of the casing of the magazine, and the casing further comprising a stop tab projecting internally from a front of the casing]; and

a follower residing within the casing, said follower further comprising a follower platform with one to four tines, one of the one to four tines being at a fore position that extends generally perpendicularly from the follower platform, *another of the one or more tines being at an aft position and shaped to fit into a trough in at least a portion of the aft side*, the guide rails contacting the follower to act as a guide for the follower, a groove serving as a detent situated in the follower platform to interface with the stop tab, thereby preventing the follower from eiting the magazine through the first end].

[10. The ammunition magazine of claim 9, wherein the follower platform comprises a second tine at an aft position of the follower that extends generally perpendicularly therefrom.]

11. The ammunition magazine of claim [10] 9, [wherein the casing further comprises a ridge, centrally located on an interior side of the fore side,] wherein a front face of one of the one to four tines presses against the ridge.

[12. The ammunition magazine of claim 9, wherein the casing further comprises a ridge, centrally located on an interior side of the fore side, wherein a front face of one of the one to four tines presses against the ridge.]

13. The ammunition magazine of claim 9, wherein one or more of the one to four tines is split into two regions via a vertical gap arranged at a center of the one or more tines.

14. *The ammunition magazine of claim 1, further comprising a stop tab projecting internally from a front of the casing.*

15. *The ammunition magazine of claim 14, further comprising a groove serving as a detent situated in the follower platform to interface with the stop tab.*

16. *The ammunition magazine of claim 9, further comprising a groove serving as a detent situated in the follower platform to interface with a stop tab, thereby preventing the follower from exiting the ammunition magazine through the first end.*

17. *The ammunition magazine of claim 9, wherein the casing further comprises a constant internal curve initiating at the second open end and continuing through a majority of the casing of the ammunition magazine.*

18. *The ammunition magazine of claim 9, wherein the casing further comprises a stop tab projecting internally from a front of the casing.*

* * * * *