



US00RE49030E

(19) **United States**
(12) **Reissued Patent**
Van Winkle

(10) **Patent Number: US RE49,030 E**
(45) **Date of Reissued Patent: *Apr. 12, 2022**

(54) **MANUALLY CONTROLLABLE LED
CORRELATED COLOR TEMPERATURE
LIGHT FIXTURE**

(58) **Field of Classification Search**
CPC F21V 15/01; F21V 19/002; F21V 23/04;
H05B 45/20; H05B 47/10; F21S 8/026;
F21S 10/02; Y02B 20/30; F21Y 2115/10
See application file for complete search history.

(71) Applicant: **ETi Solid State Lighting Inc.**, Vernon Hills, IL (US)

(56) **References Cited**

(72) Inventor: **Gary Van Winkle**, Chagrin Falls, OH (US)

U.S. PATENT DOCUMENTS

(73) Assignee: **ETi Solid State Lighting Inc.**, Wheeling, IL (US)

6,357,889 B1 3/2002 Duggal et al.
6,834,981 B2 12/2004 Nagai et al.
(Continued)

(*) Notice: This patent is subject to a terminal disclaimer.

FOREIGN PATENT DOCUMENTS

(21) Appl. No.: **16/402,933**

CN 204069421 U 12/2014
CN 105221949 A 1/2016
(Continued)

(22) Filed: **May 3, 2019**

OTHER PUBLICATIONS

Related U.S. Patent Documents

Reissue of:

(64) Patent No.: **10,091,855**
Issued: **Oct. 2, 2018**
Appl. No.: **15/871,433**
Filed: **Jan. 15, 2018**

Hampton Bay. Use and Care Guide. LED Universal Ceiling Fan Kit. Item 1001518521, Model #53701101. published Dec. 9, 2015. (Year: 2015).*

(Continued)

U.S. Applications:

(60) Provisional application No. 62/445,824, filed on Jan. 13, 2017.

Primary Examiner — Deandra M Hughes
(74) *Attorney, Agent, or Firm* — Walter Haverfield LLP; D. Peter Hochberg

(51) **Int. Cl.**
H05B 33/08 (2020.01)
F21V 19/00 (2006.01)
(Continued)

(57) **ABSTRACT**

An LED light fixture having at least two LED light sources, each having a different correlated color temperature, with a manually controllable correlated color temperature switching assembly to control an electric circuit to select a particular LED light source or combination of LEDs, and a concealment for selectively rendering the manually controllable color correlated color temperature switching assembly inaccessible or for rendering the switching assembly accessible for operation.

(52) **U.S. Cl.**
CPC **F21S 8/026** (2013.01); **F21V 15/01** (2013.01); **F21V 19/002** (2013.01); **F21V 23/04** (2013.01);
(Continued)

28 Claims, 26 Drawing Sheets

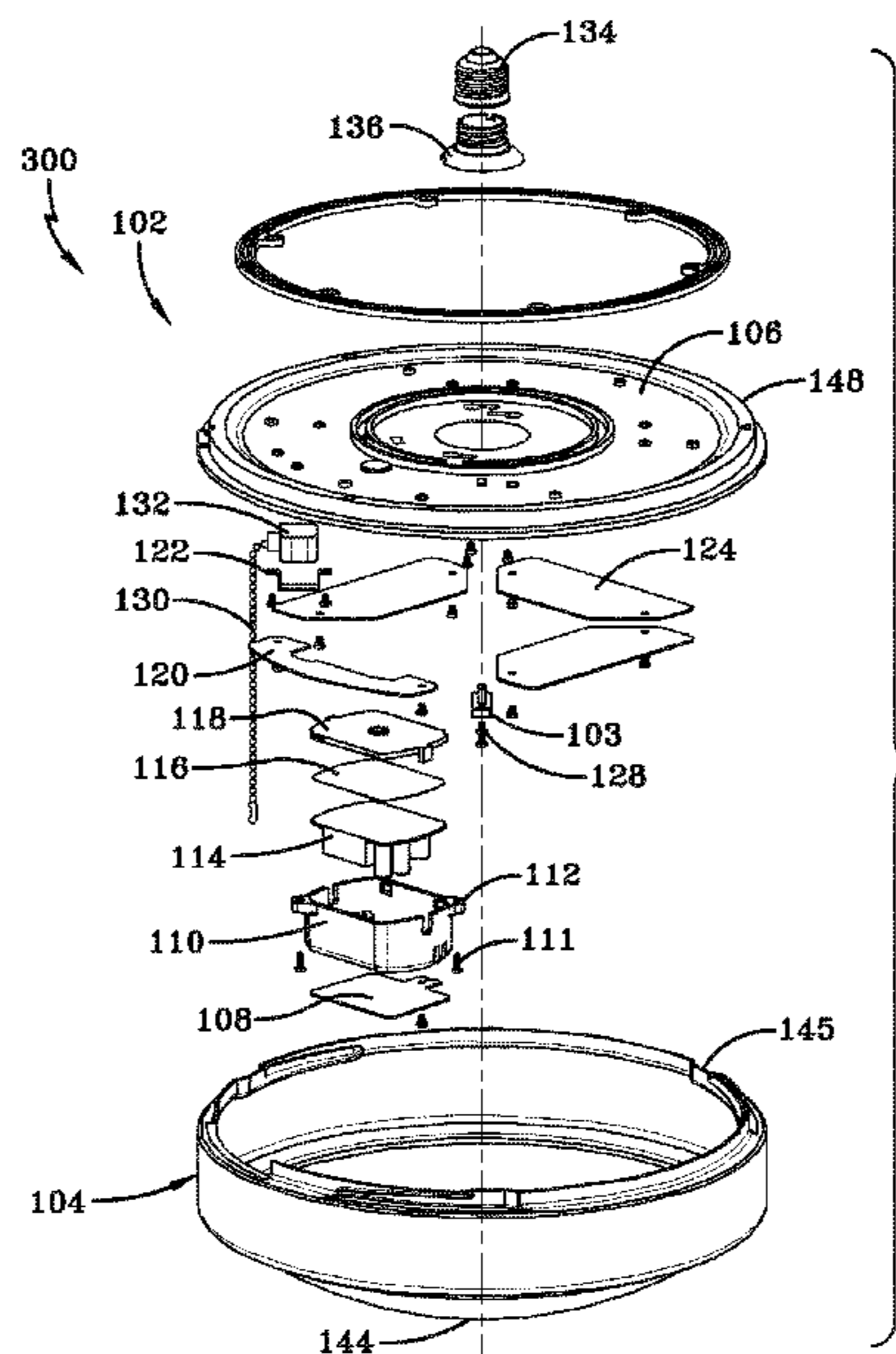

US RE49,030 E

(51) **Int. Cl.**
F21V 15/01 (2006.01)
F21S 8/02 (2006.01)
H05B 45/20 (2020.01)
H05B 47/10 (2020.01)
F21V 23/04 (2006.01)
F21Y 115/10 (2016.01)
F21S 10/02 (2006.01)

(52) **U.S. Cl.**
CPC *H05B 45/20* (2020.01); *H05B 47/10*
(2020.01); *F21S 10/02* (2013.01); *F21Y*
2115/10 (2016.08); *Y02B 20/30* (2013.01)

(56) **References Cited**

U.S. PATENT DOCUMENTS

7,014,336	B1	3/2006	Ducharme et al.				
7,201,489	B2*	4/2007	Shyu	F04D 25/088			
				362/147			
7,405,715	B2	7/2008	Guzman et al.				
7,520,634	B2	4/2009	Ducharme et al.				
7,521,667	B2	4/2009	Rains, Jr. et al.				
7,659,674	B2	2/2010	Mueller et al.				
7,883,239	B2	2/2011	Rains, Jr. et al.				
7,988,327	B1	8/2011	Knoble et al.				
8,207,821	B2	6/2012	Roberge et al.				
8,220,970	B1	7/2012	Khazi et al.				
8,314,571	B2	11/2012	Jonsson				
8,430,402	B2	4/2013	Diehl et al.				
8,669,722	B2	3/2014	Yeh et al.				
8,884,508	B2	11/2014	Pickard et al.				
9,232,602	B2	1/2016	Yeh et al.				
9,642,208	B2	5/2017	Van de Ven				
9,730,291	B1	8/2017	Janik et al.				
9,786,639	B2	10/2017	Bergmann et al.				
9,799,125	B1	10/2017	Wegner et al.				
9,801,250	B1*	10/2017	Halliwell	H05B 45/10			

9,820,350	B2	11/2017	Pyshos et al.				
9,892,693	B1*	2/2018	Kumar	H05B 45/24			
9,900,945	B1	2/2018	Janik et al.				
9,909,723	B2	3/2018	Bergmann et al.				
9,924,582	B2	3/2018	Vendetti et al.				
9,974,138	B2	5/2018	Allen et al.				
10,008,484	B2	6/2018	Bergmann et al.				
10,009,971	B2	6/2018	Chobot et al.				
10,018,346	B2	7/2018	Van De Ven et al.				
10,076,011	B1	9/2018	Amid et al.				
10,091,855	B2	10/2018	Van Winkle				
10,117,300	B2*	10/2018	Doheny	H05B 47/19			
10,231,300	B2	3/2019	Cash et al.				
10,278,250	B2	4/2019	McBryde et al.				
10,292,233	B1*	5/2019	Udavant	F21S 8/026			
10,299,335	B2	5/2019	Pyshos et al.				
10,334,678	B2	6/2019	Janik et al.				
2005/0012457	A1	1/2005	Wu				
2006/0237636	A1	10/2006	Lyons et al.				
2014/0264406	A1*	9/2014	Muehlbacher	H01L 33/50			
				257/89			
2015/0029712	A1	1/2015	Nakamura et al.				
2015/0296577	A1	10/2015	Chen				
2016/0316527	A1	10/2016	Allen et al.				
2017/0303363	A1*	10/2017	Pyshos	F21V 5/04			
2017/0354022	A1	12/2017	Dimberg et al.				
2018/0206305	A1	7/2018	Van Winkle				

FOREIGN PATENT DOCUMENTS

DE	202011103835	U1	12/2011				
JP	2013254666	A	12/2013				

OTHER PUBLICATIONS

Hampton Bay, Use and Care Guide, LED Universal Ceiling Fan Light Kit.

* cited by examiner

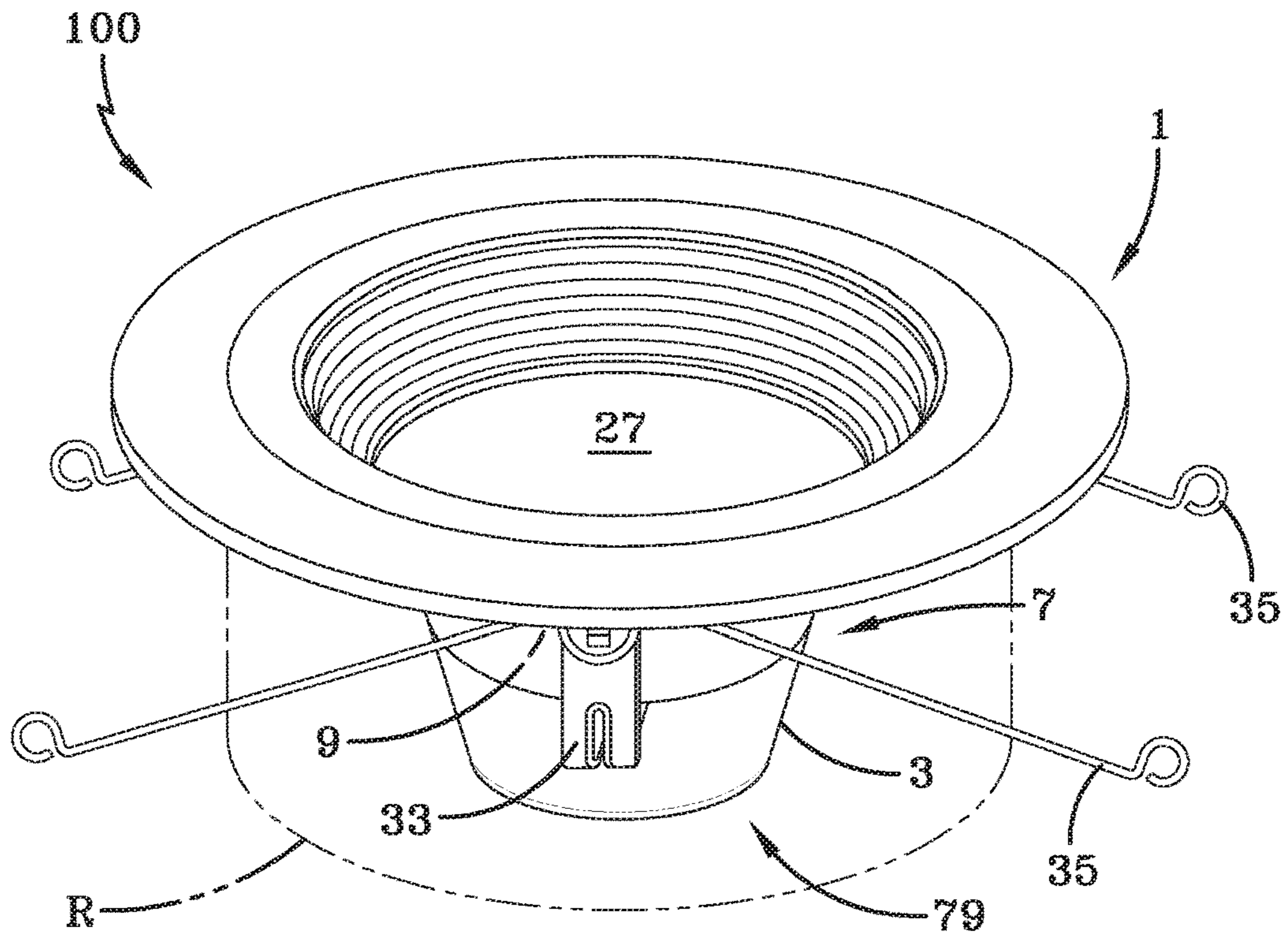

FIG-1

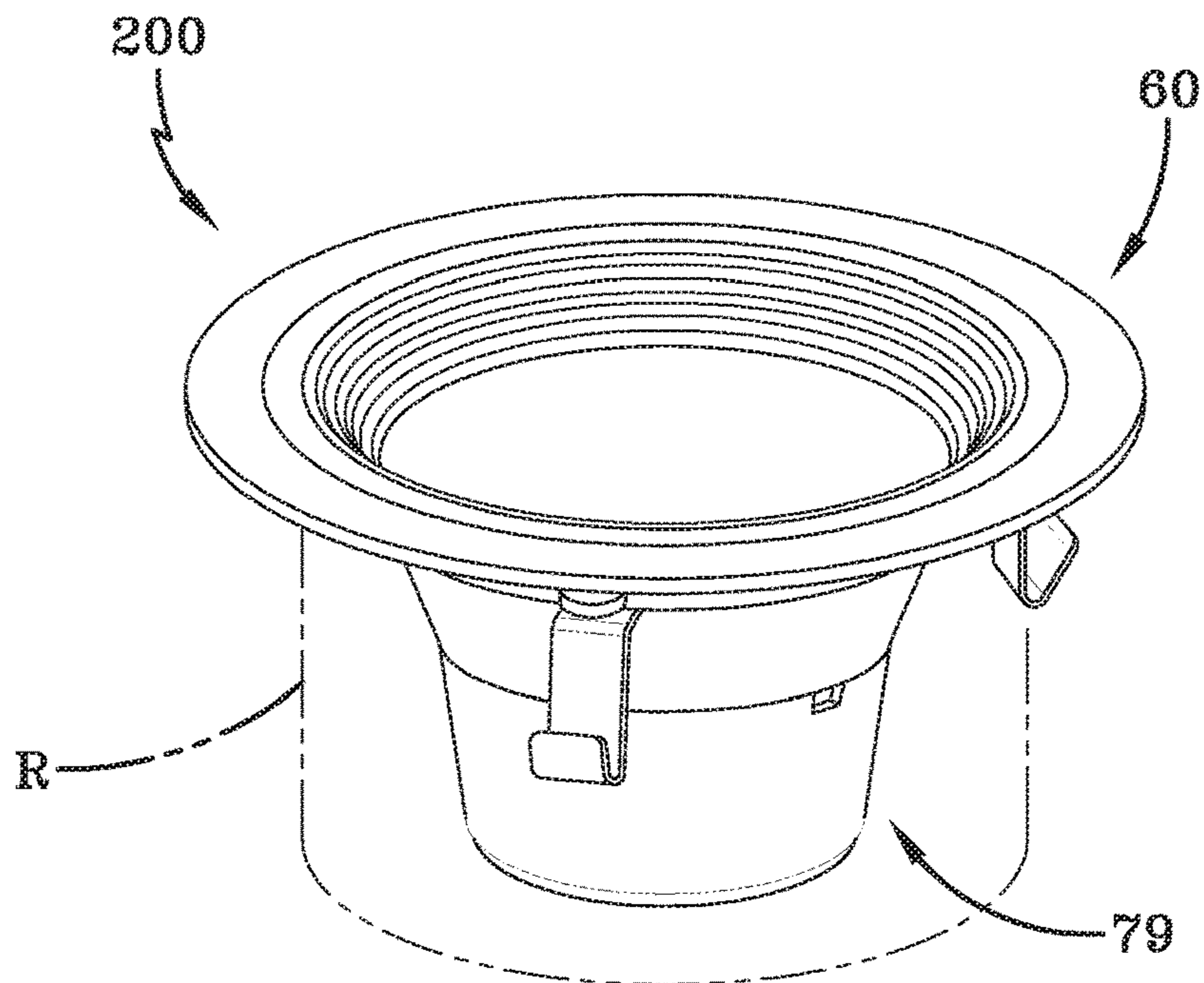

FIG-2

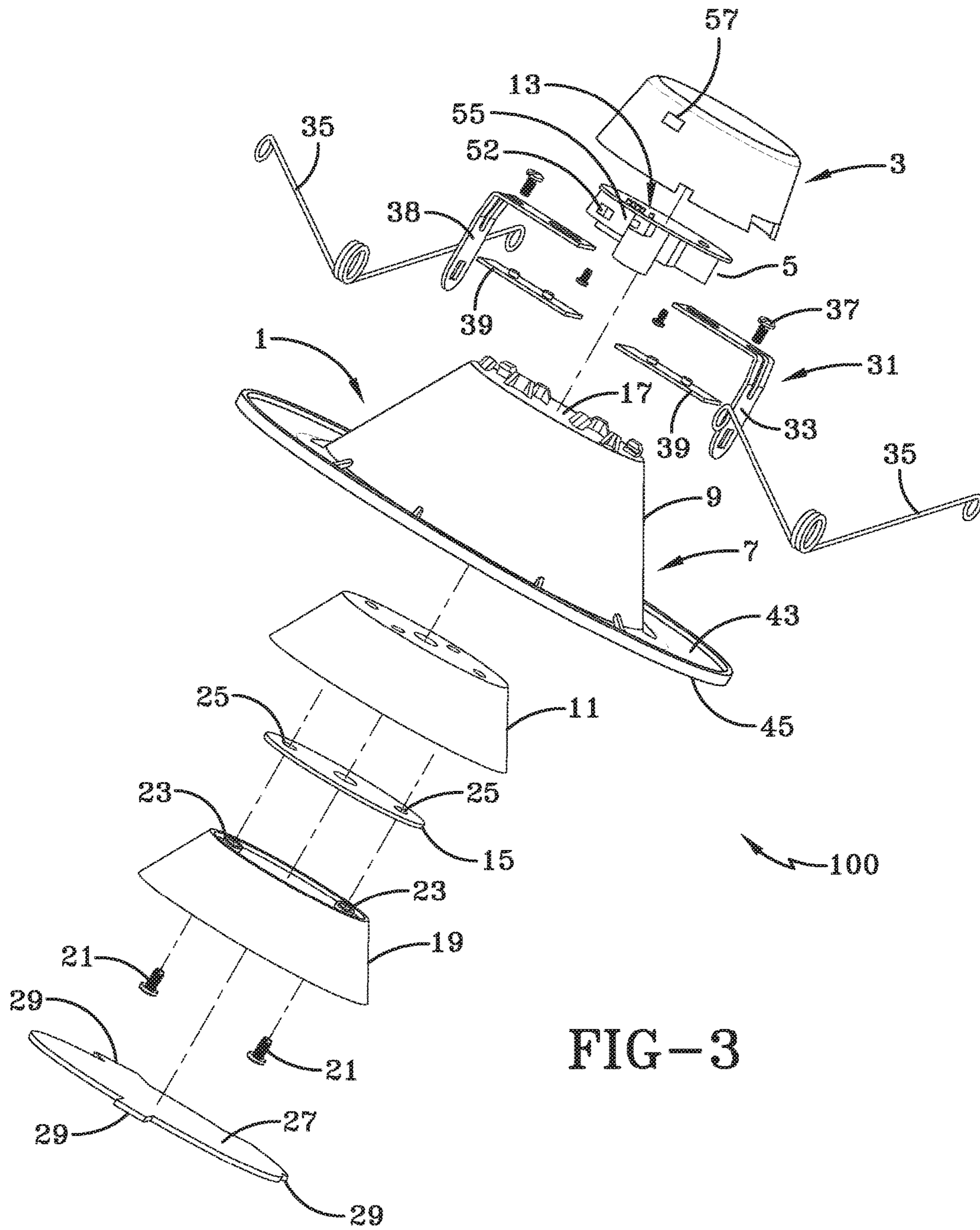
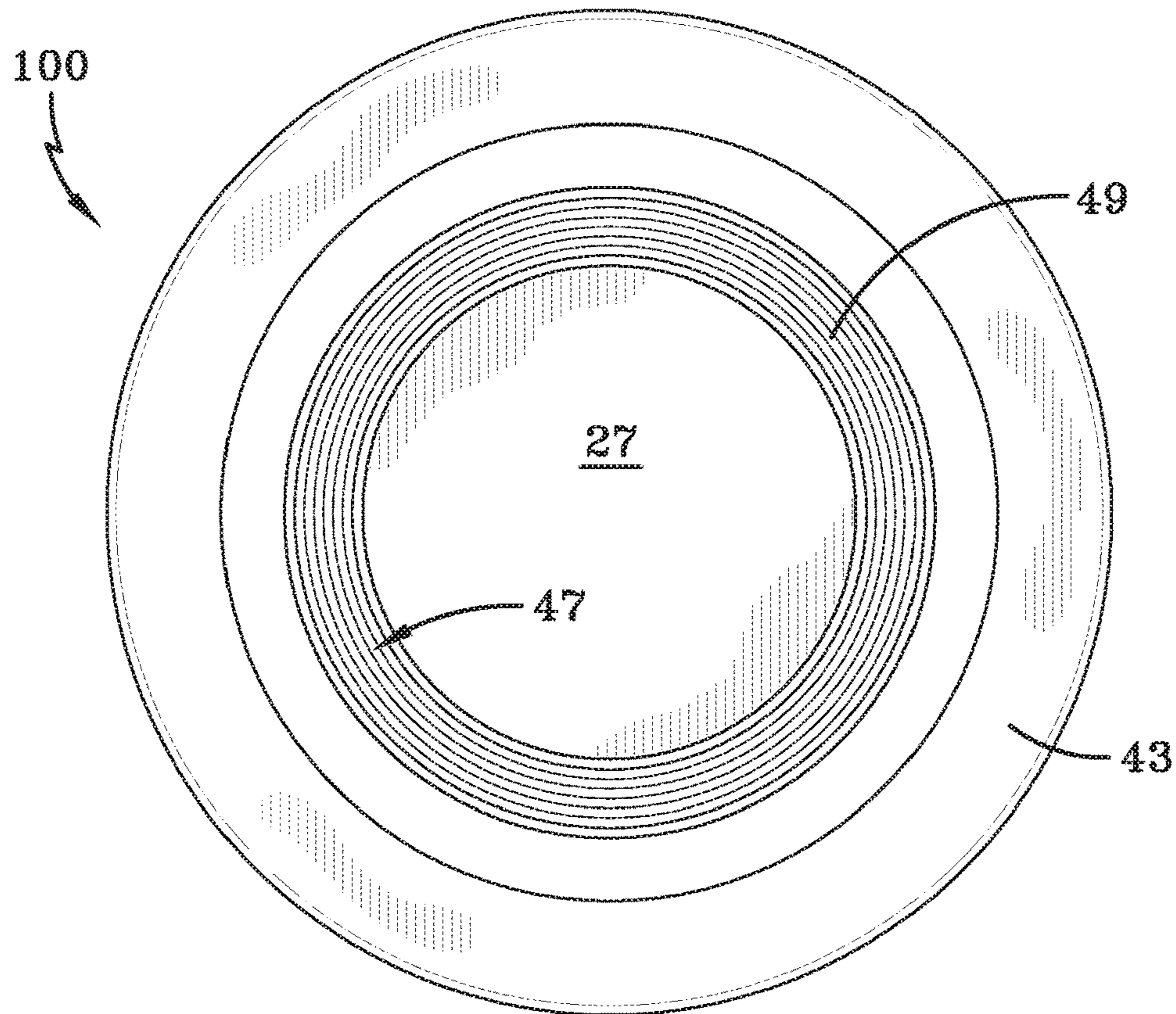
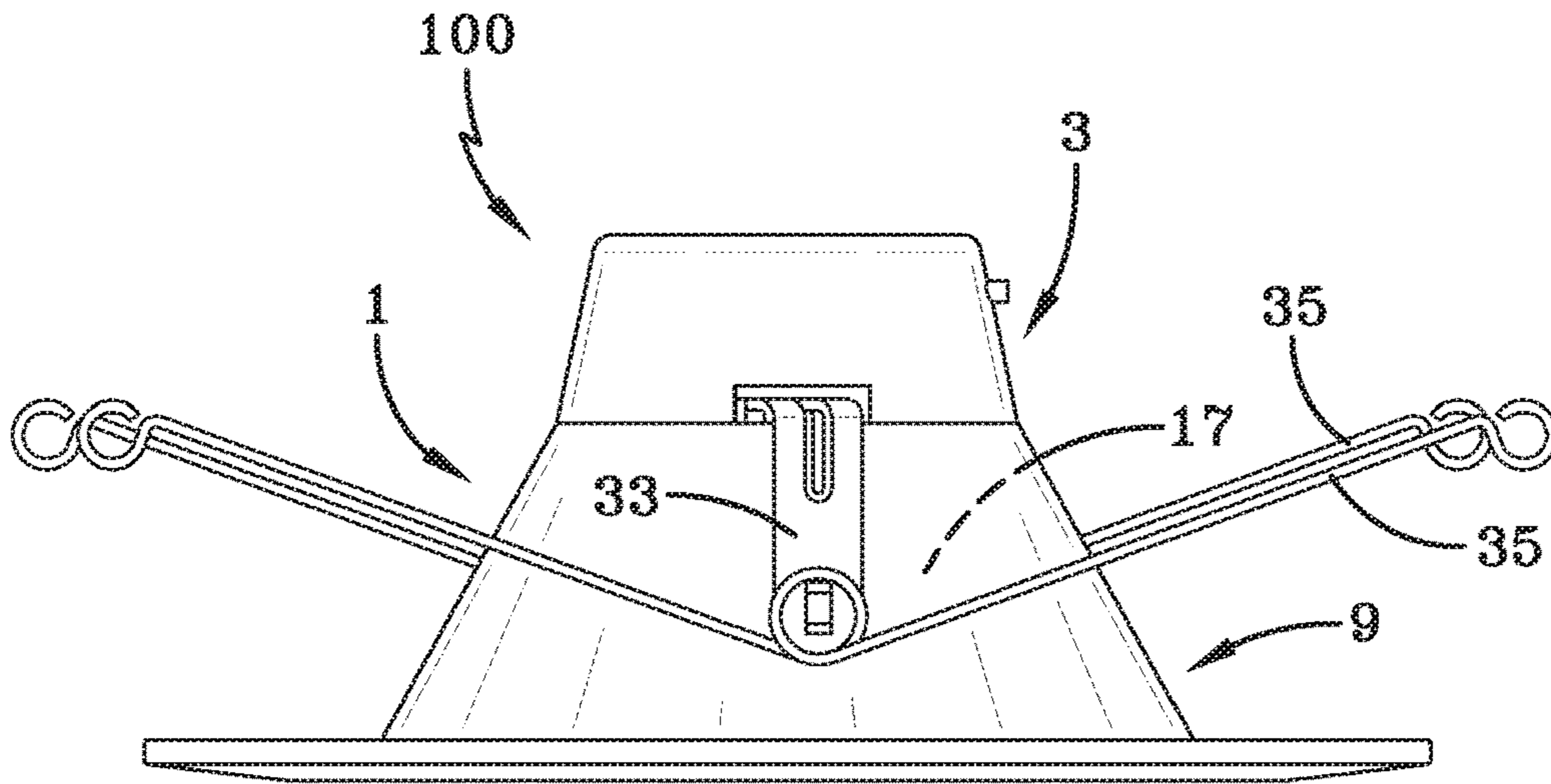

FIG-3



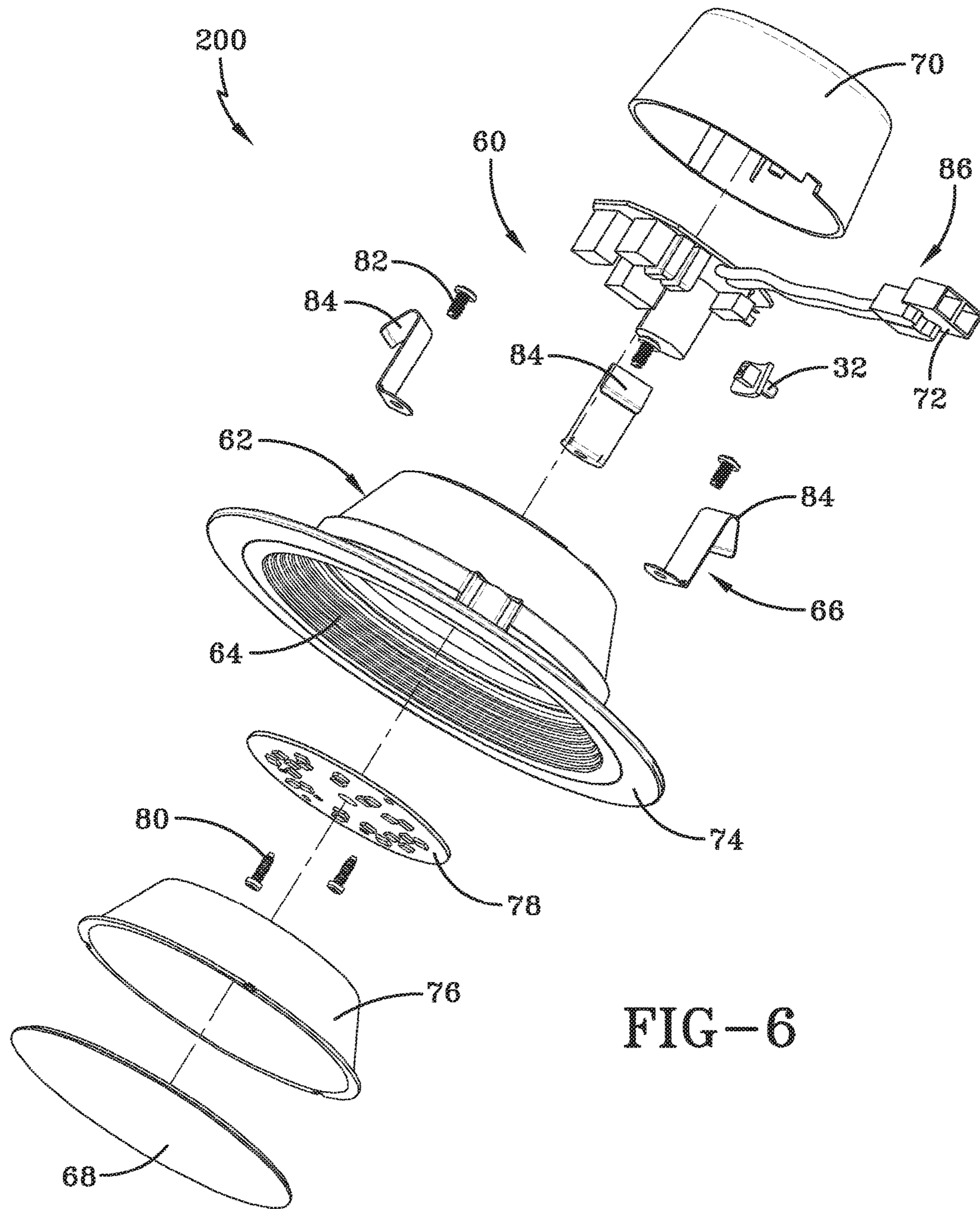

FIG-6

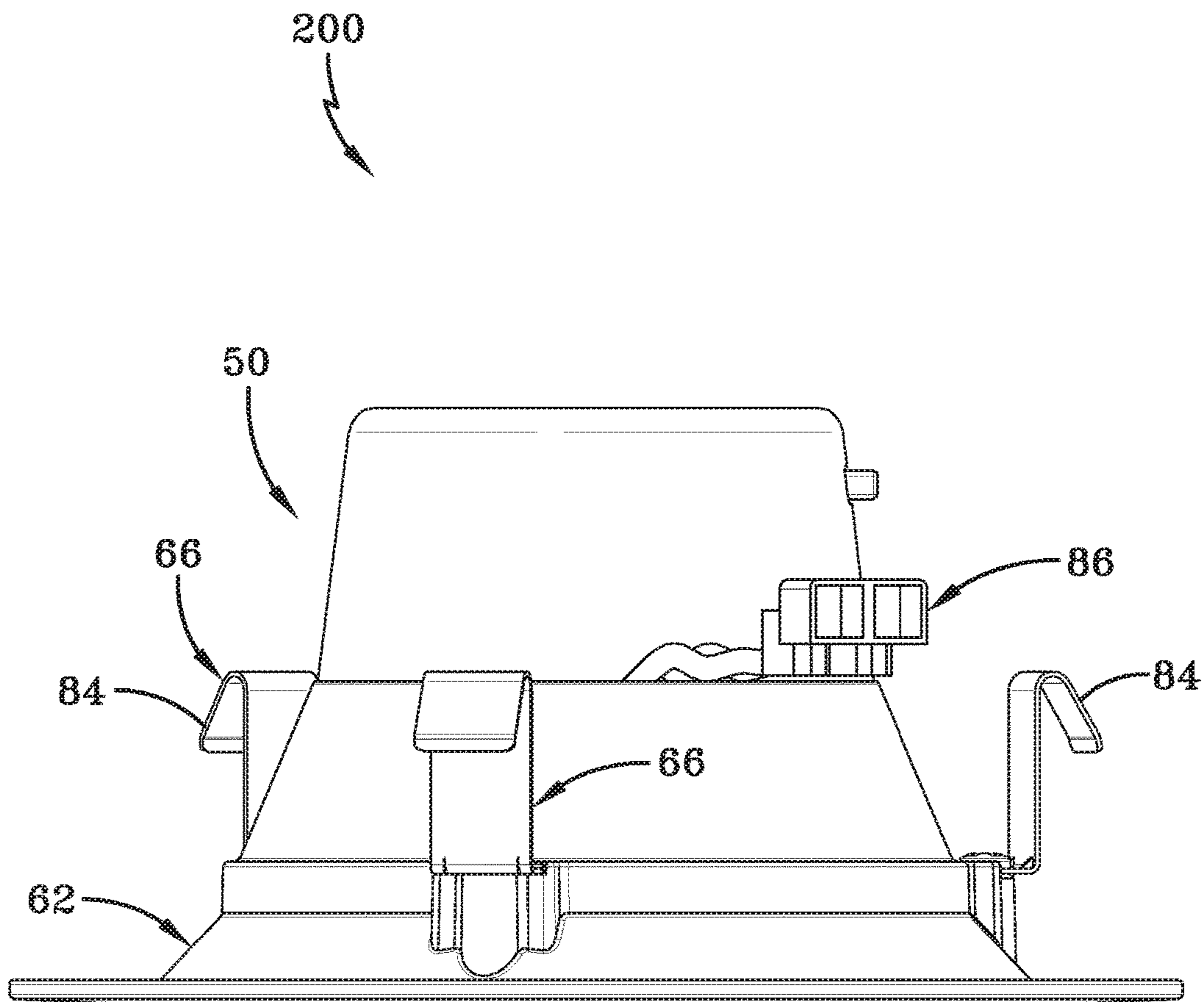

FIG-7

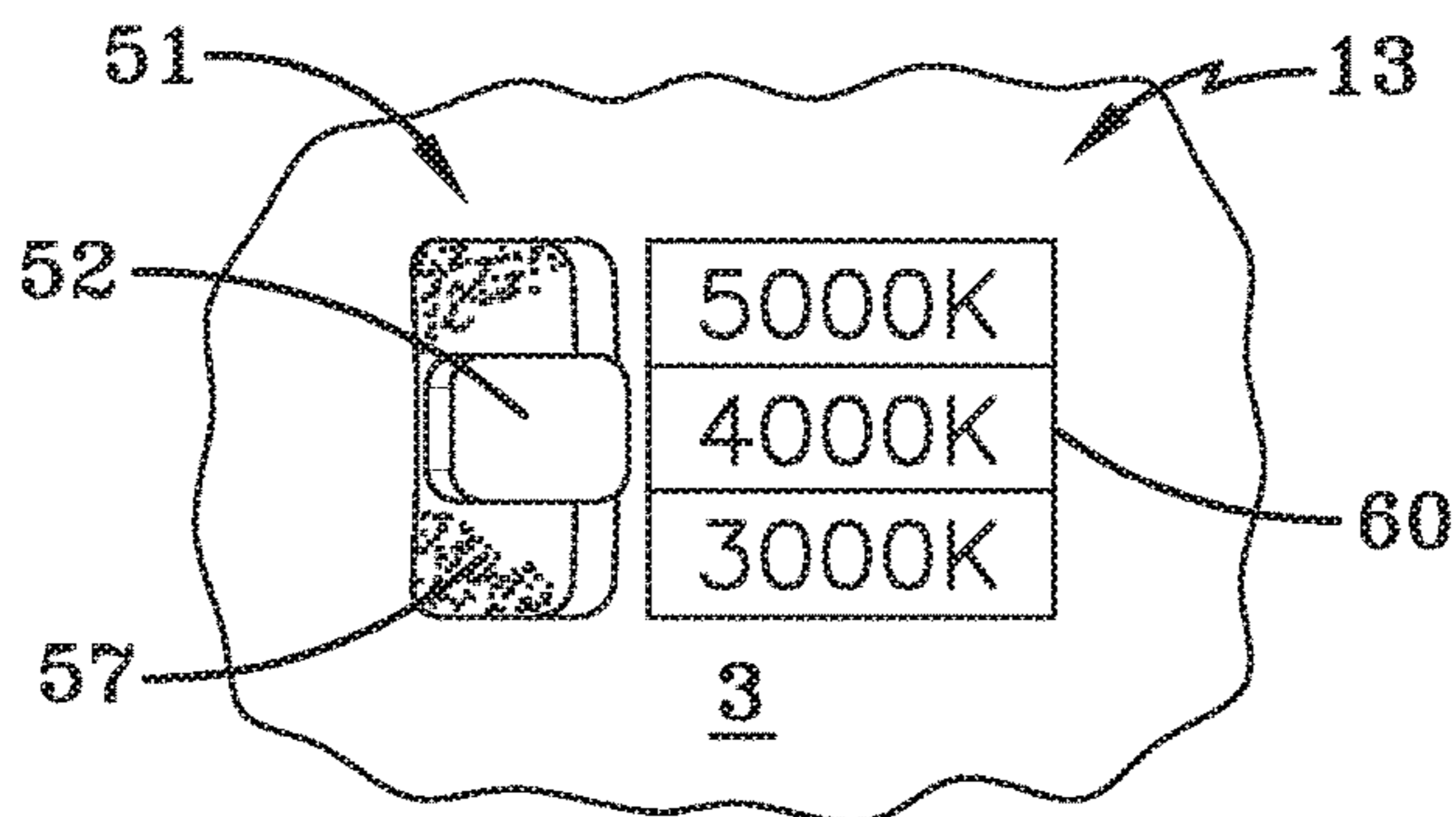

FIG-8

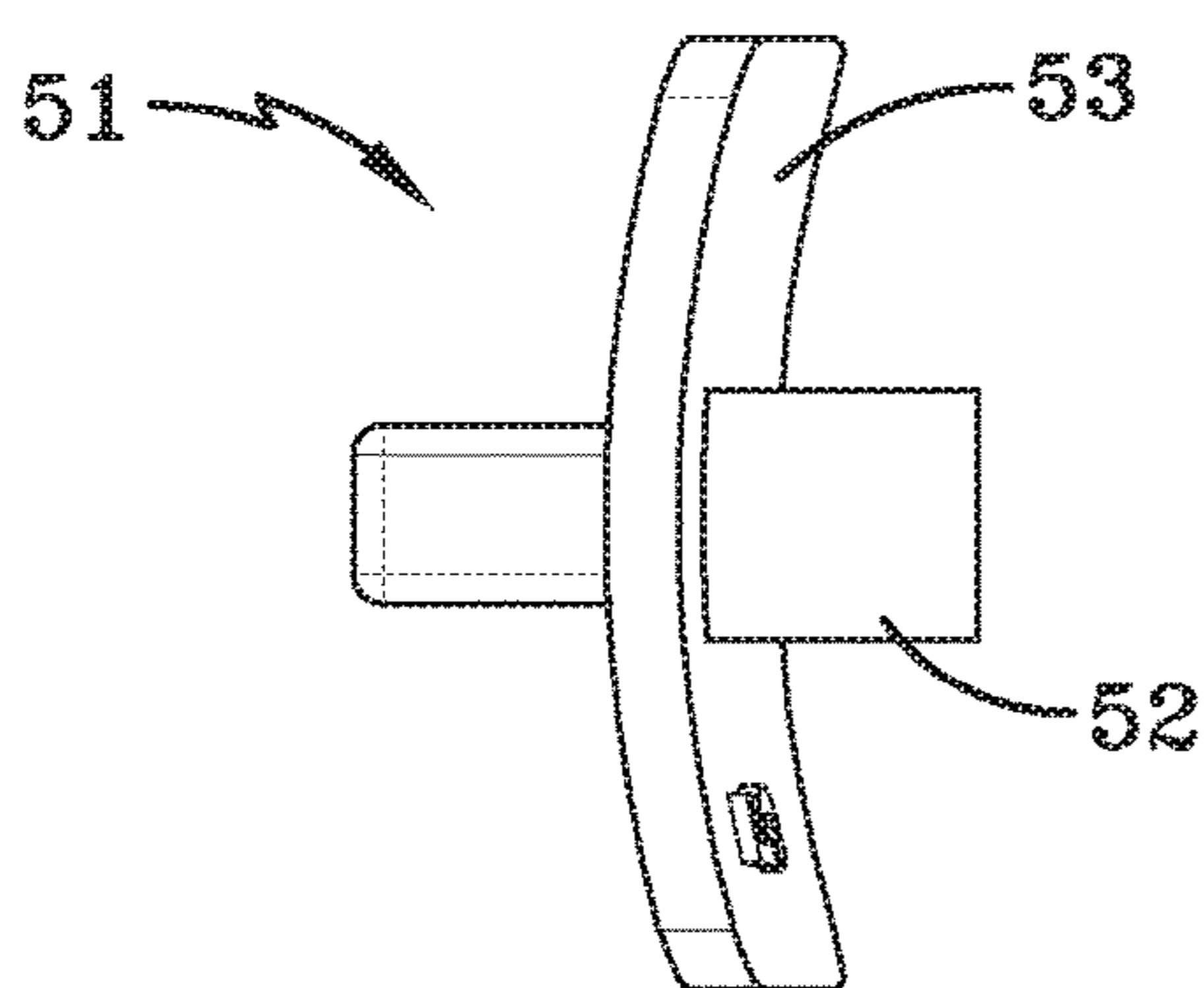

FIG-9

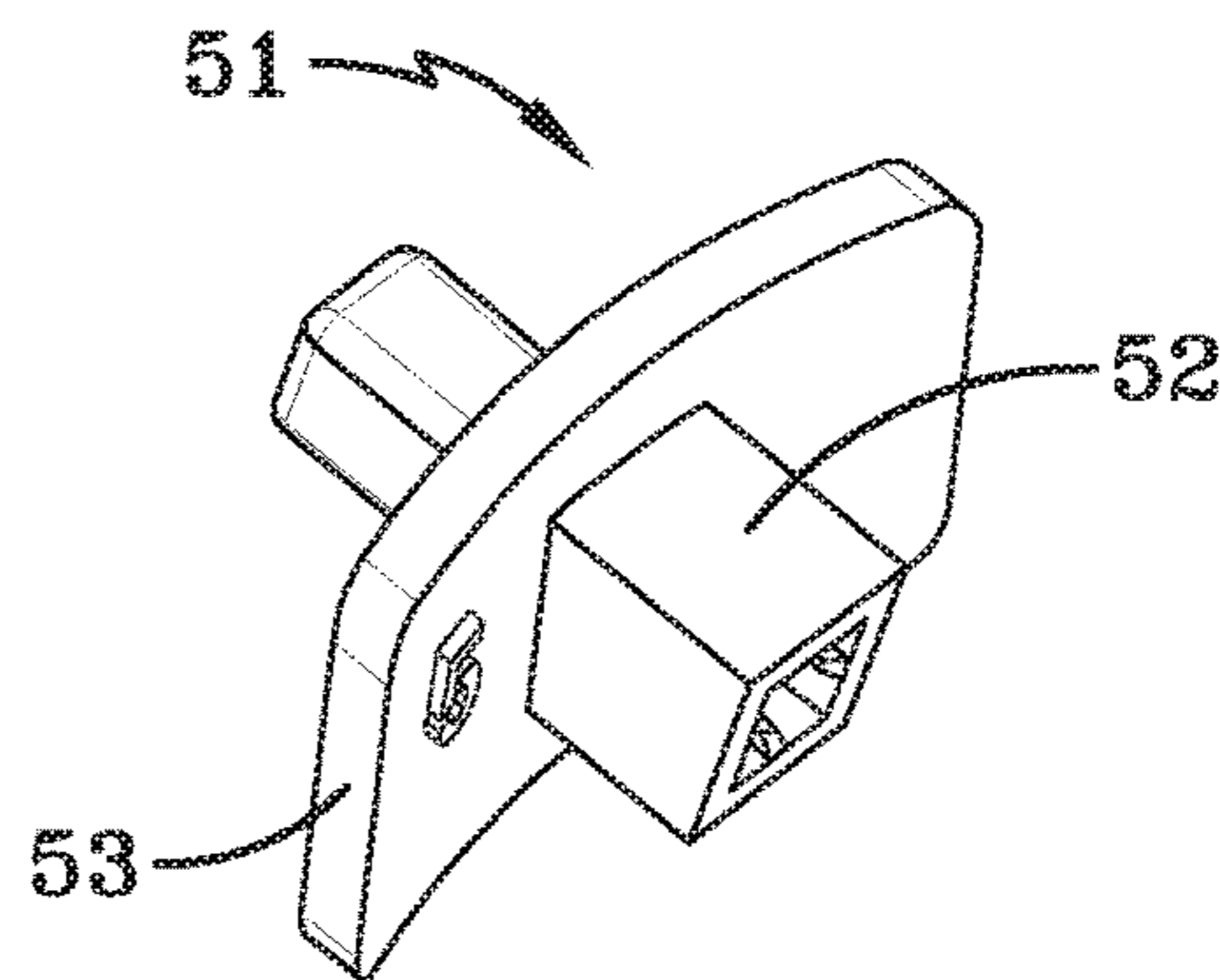

FIG-10

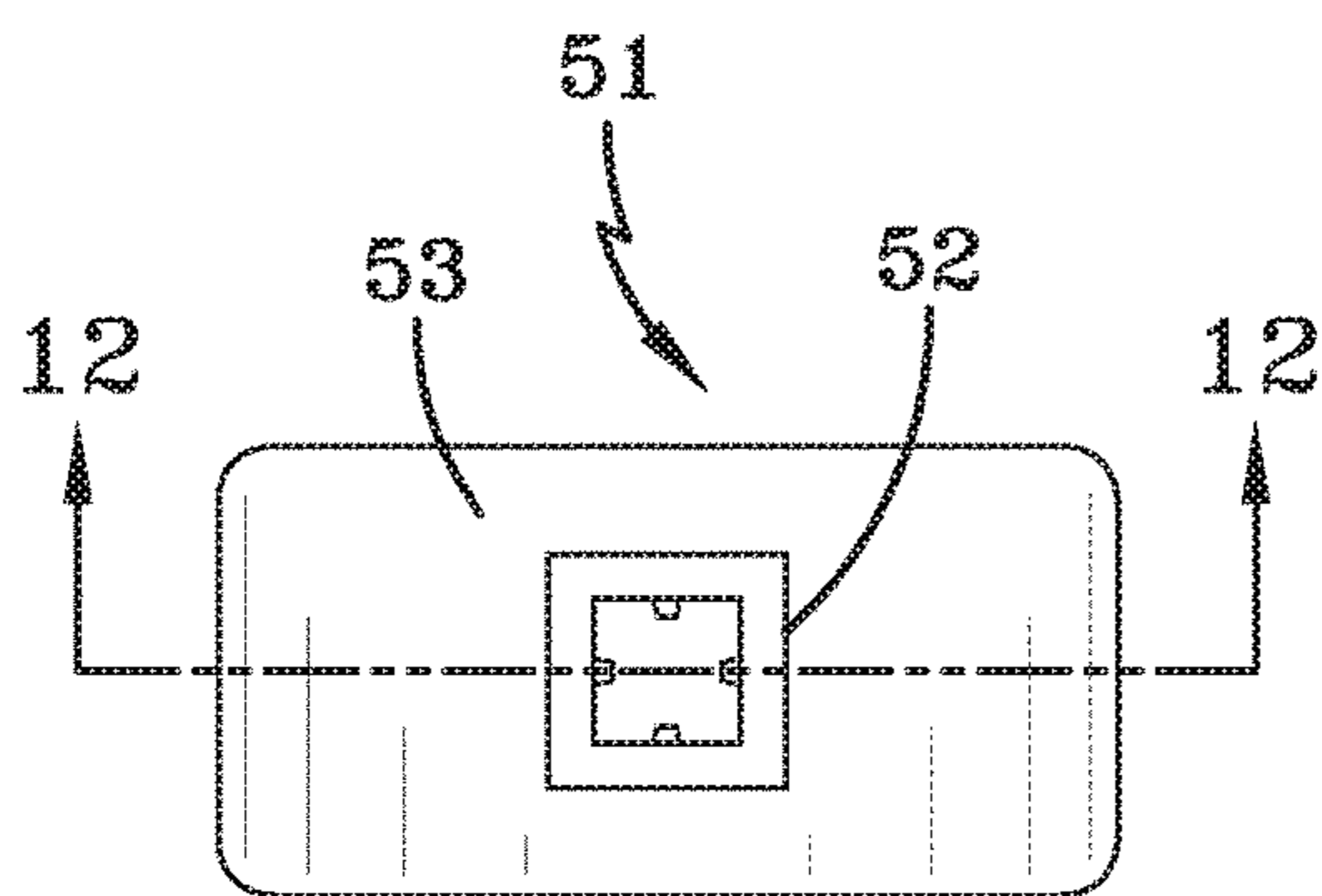

FIG-11

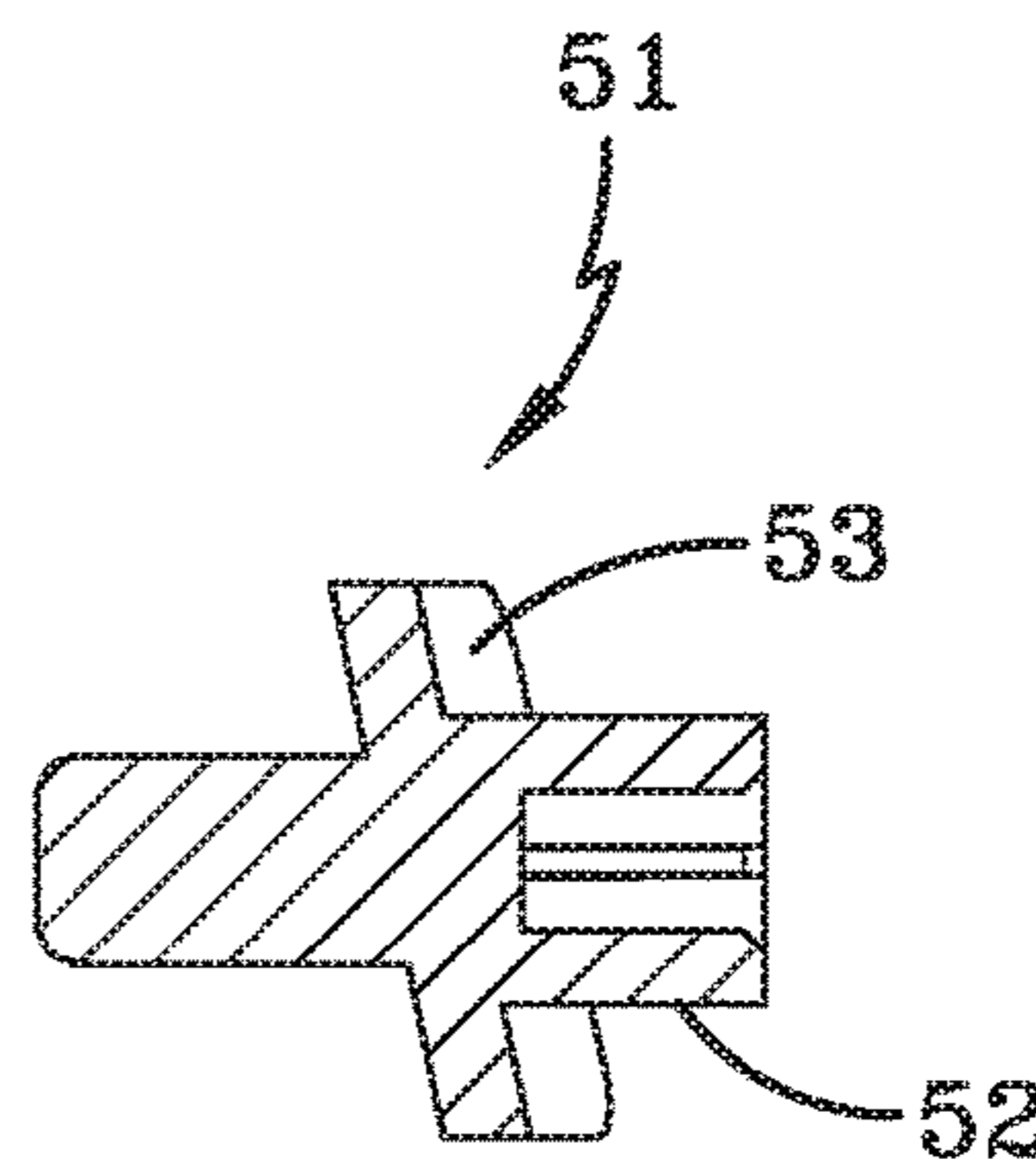

FIG-12

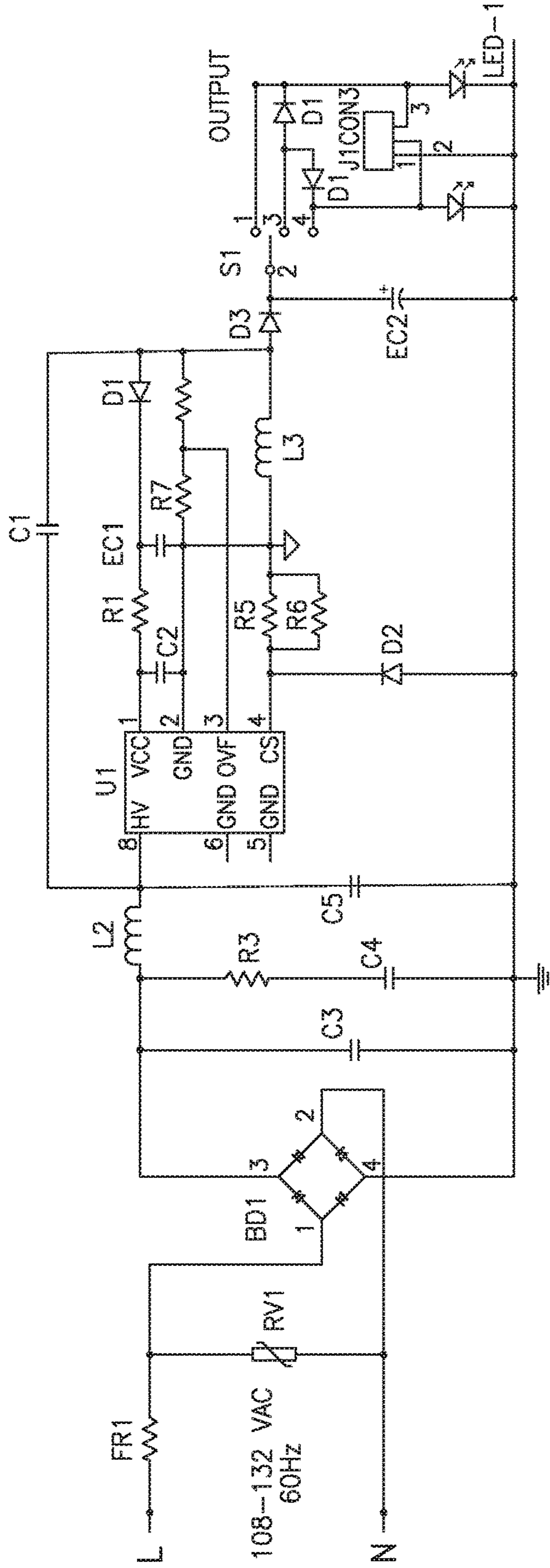

FIG-13

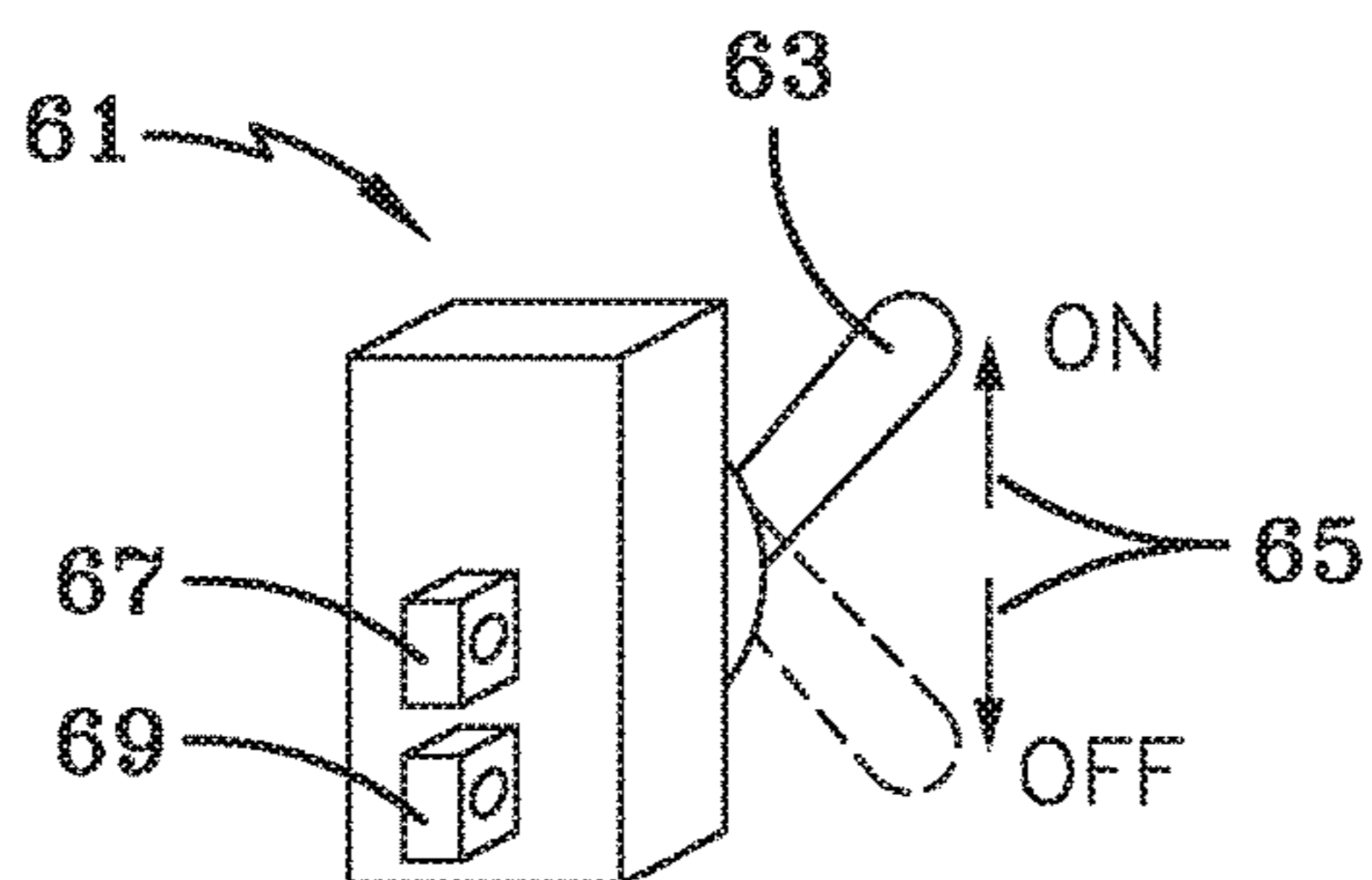

FIG-14A

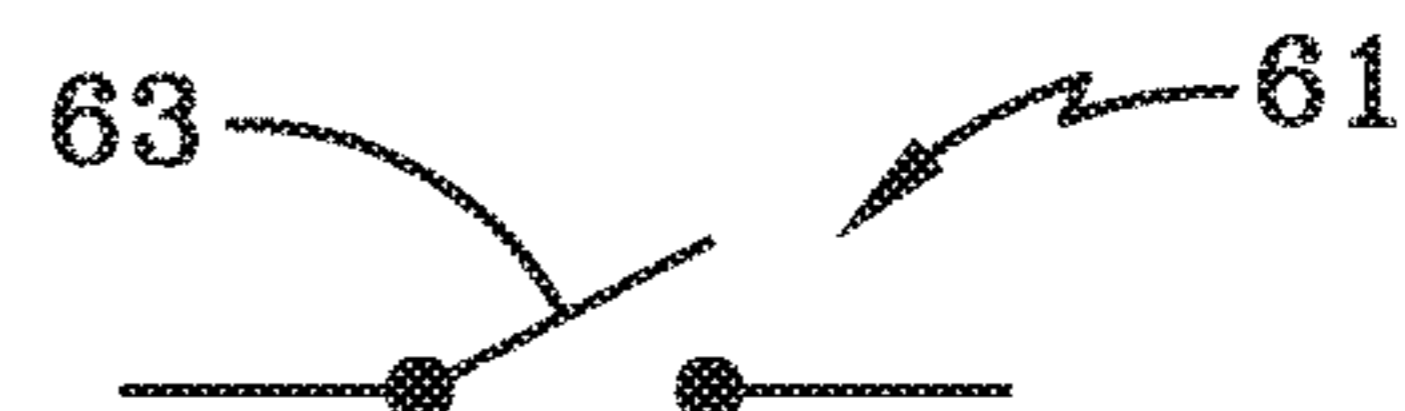

FIG-14B

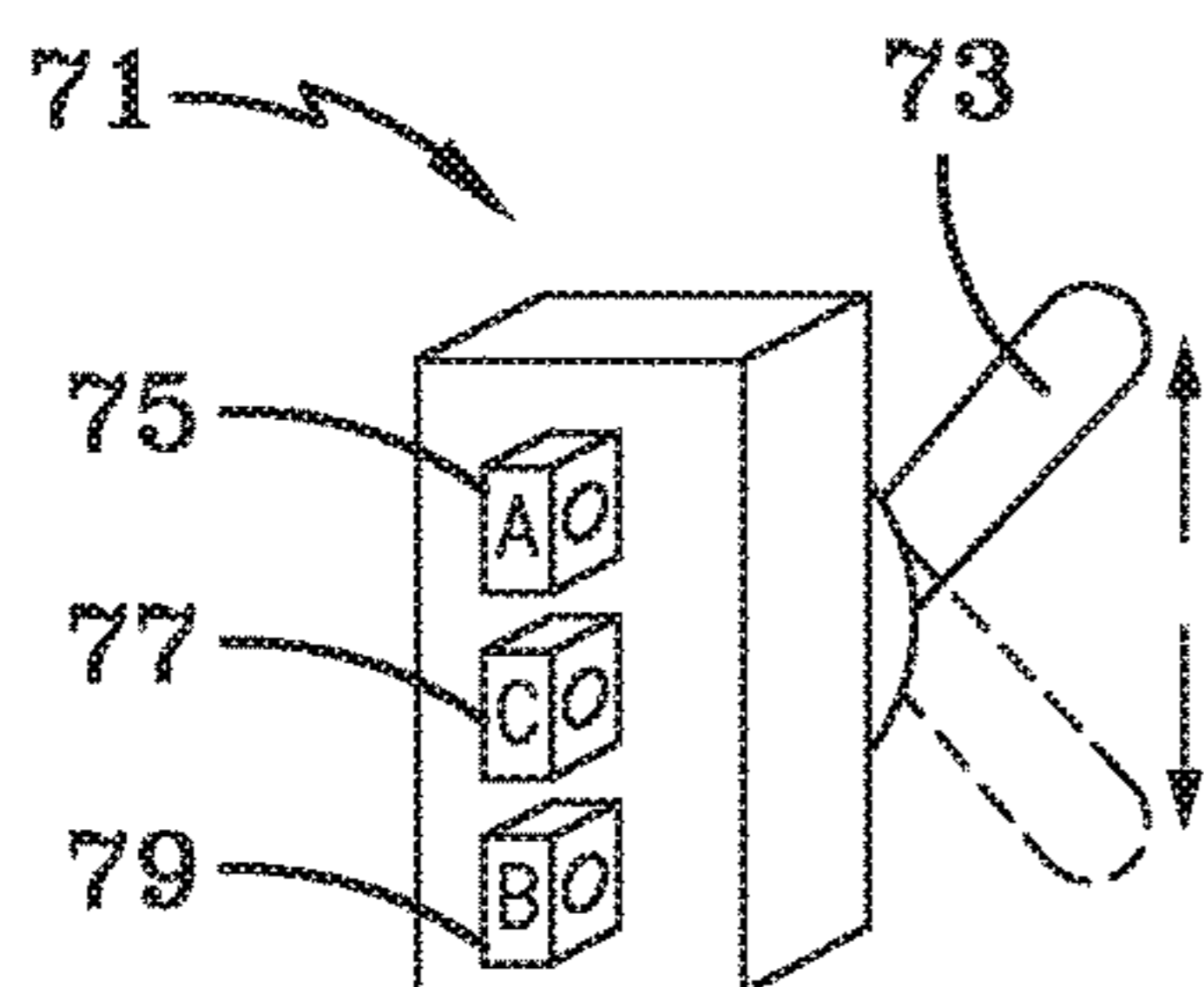

FIG-15A

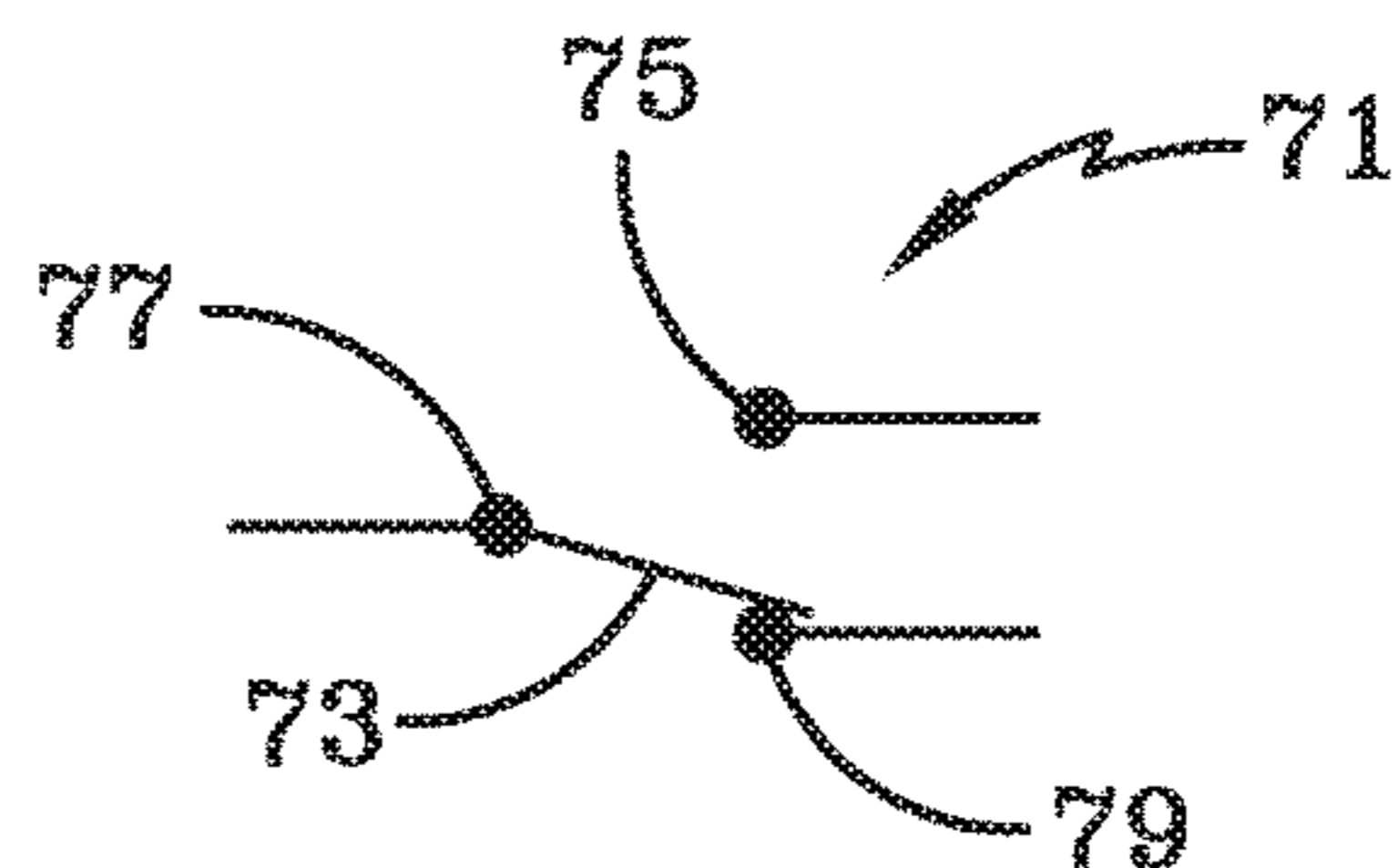

FIG-15B

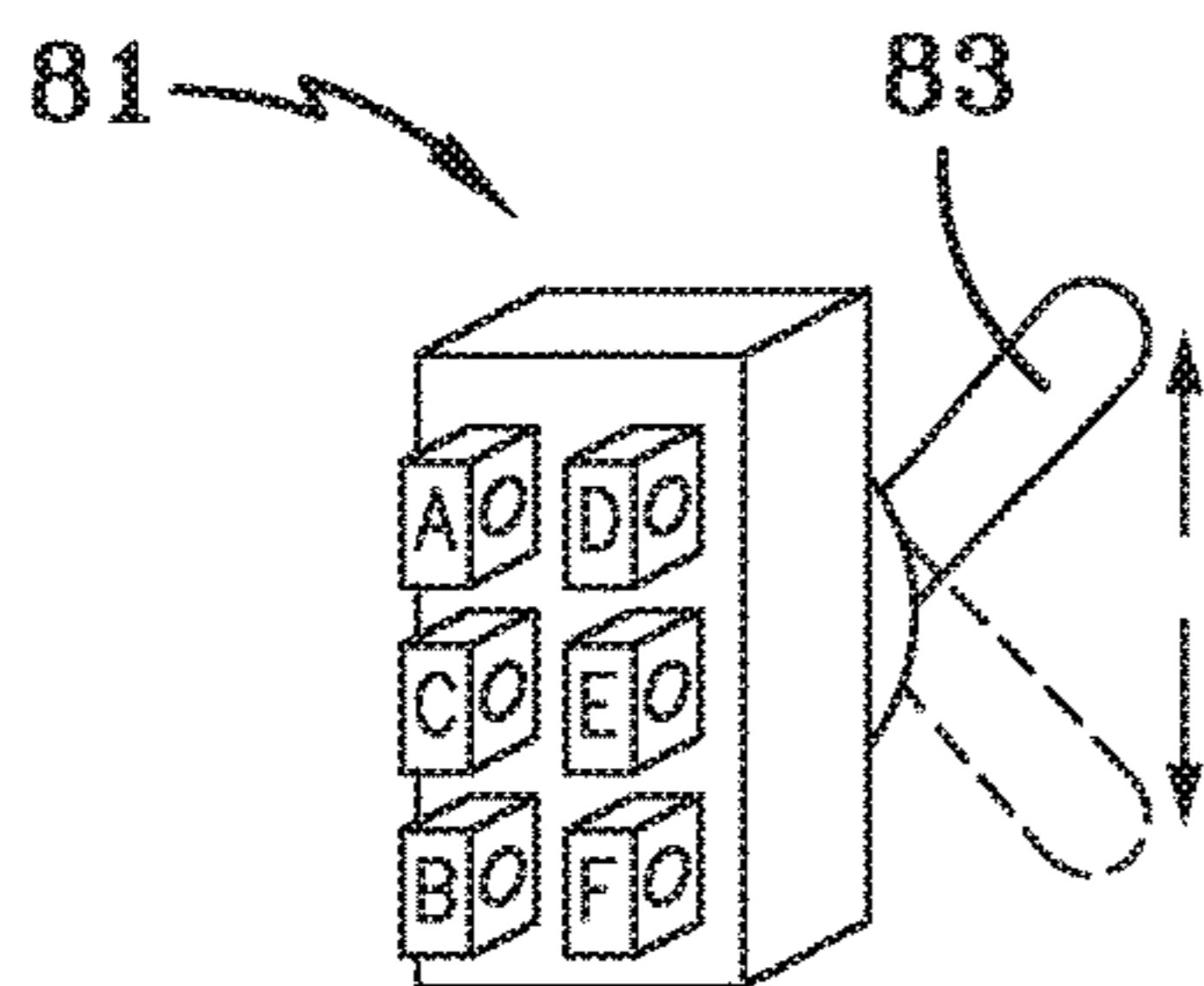

FIG-16A

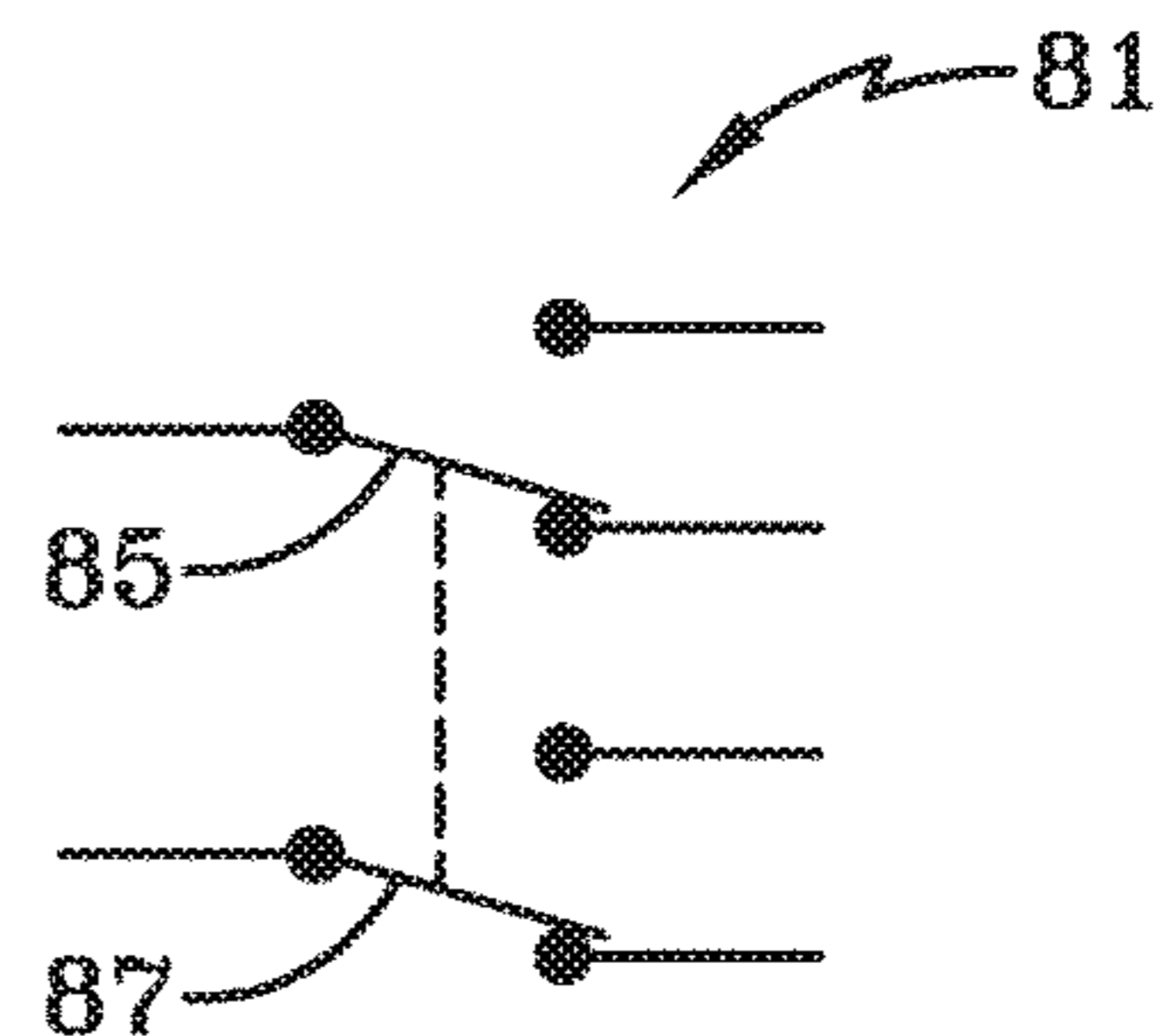

FIG-16B

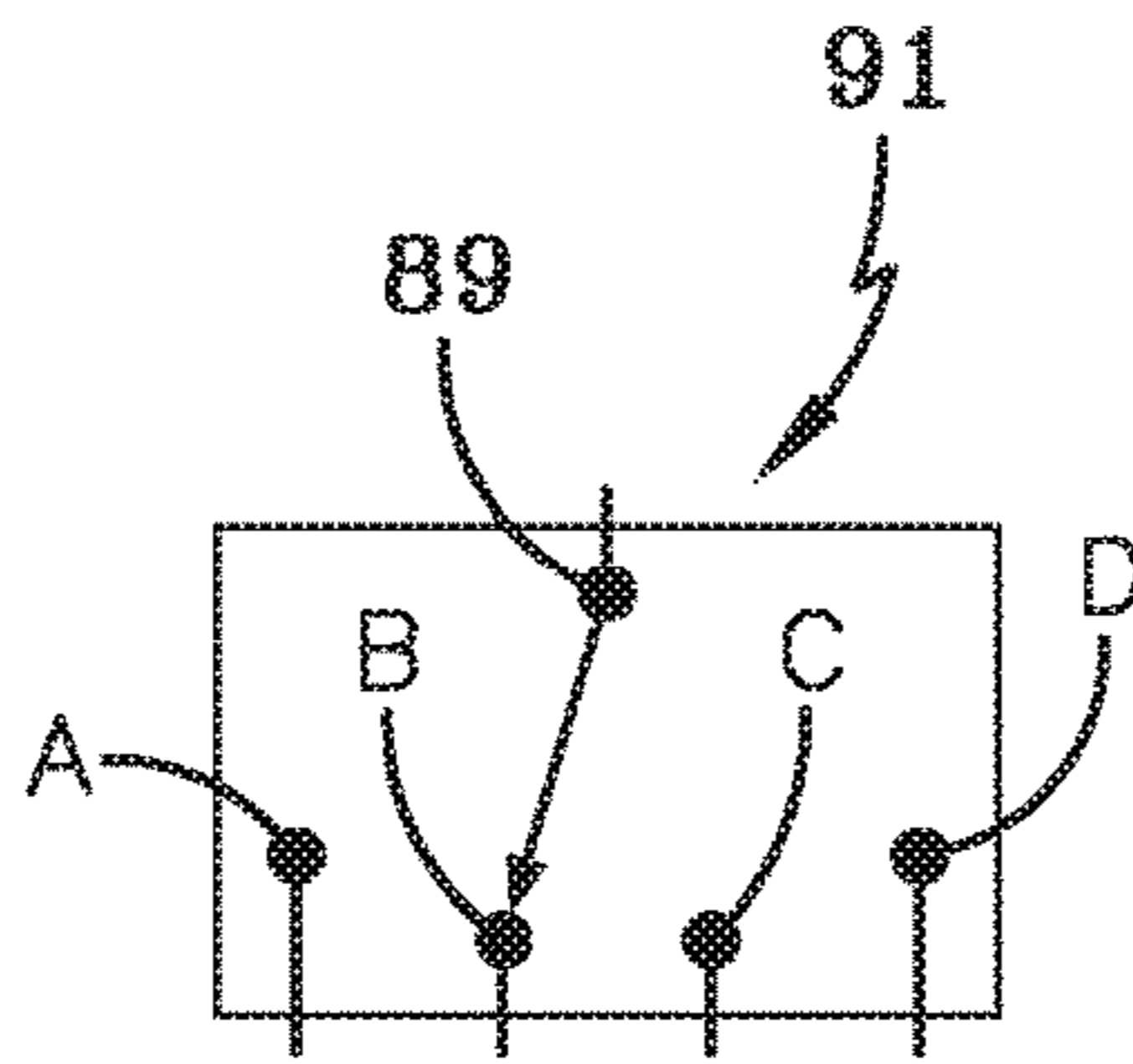

FIG-17

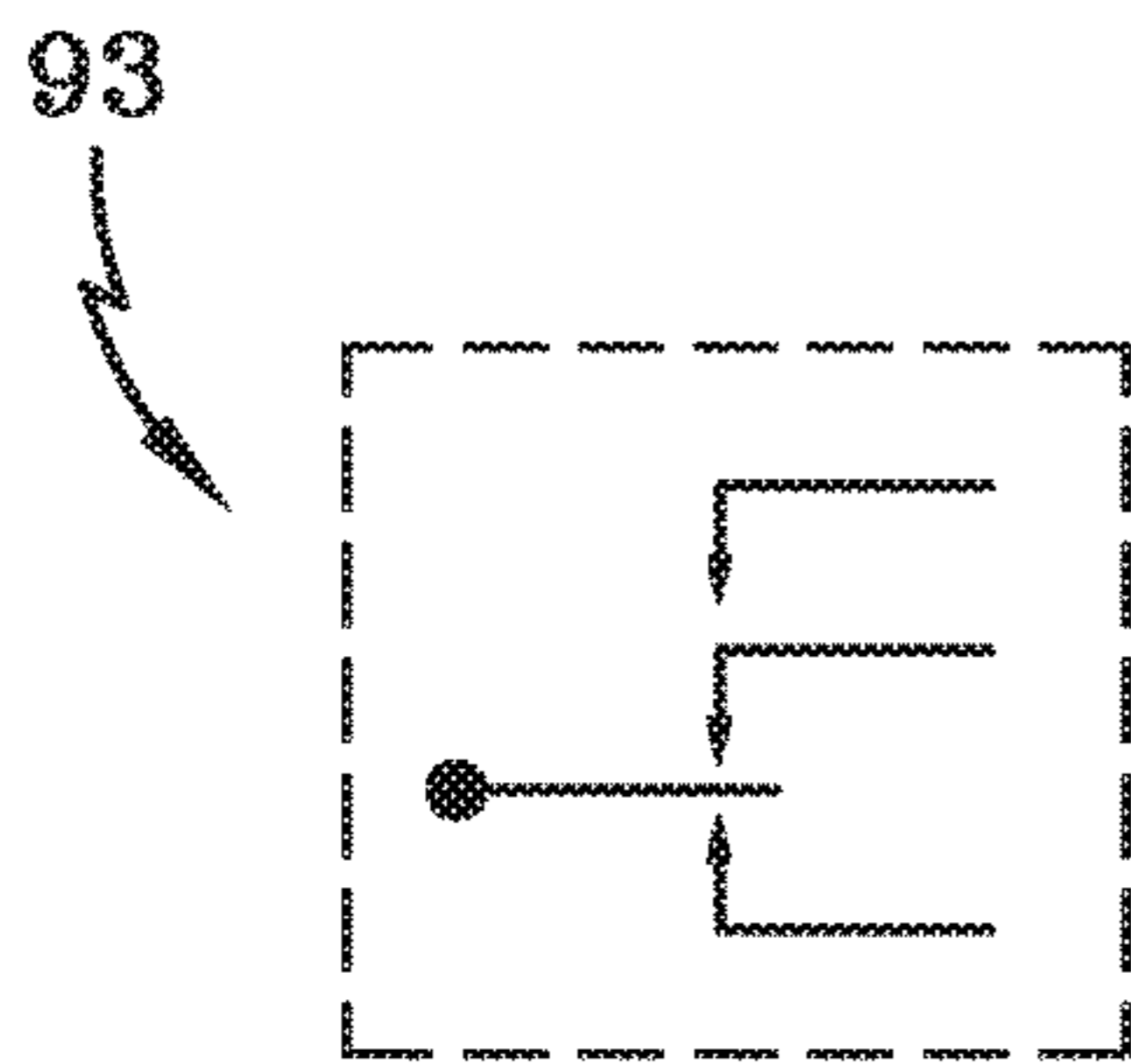

FIG-18A

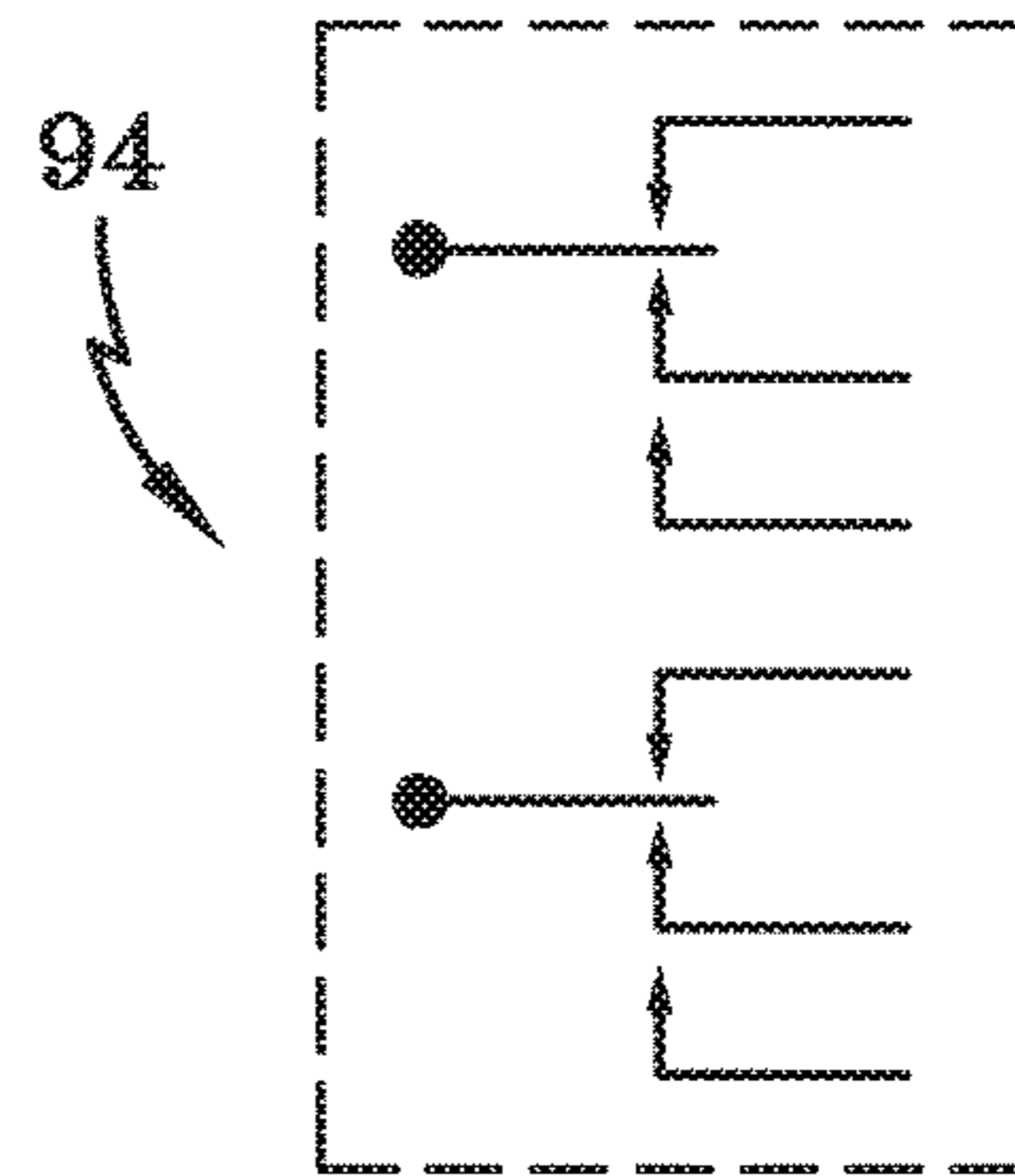

FIG-18B

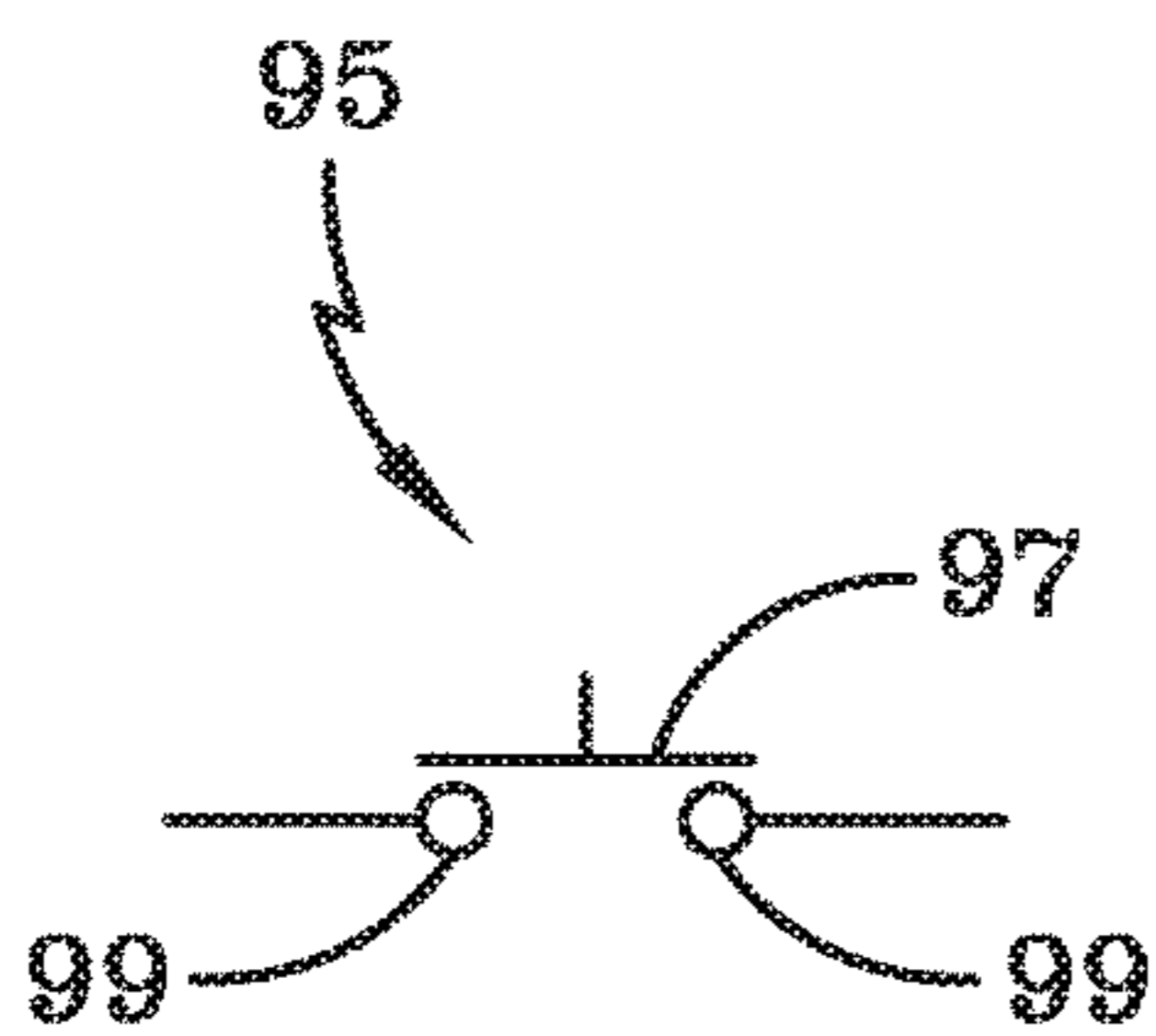

FIG-19A

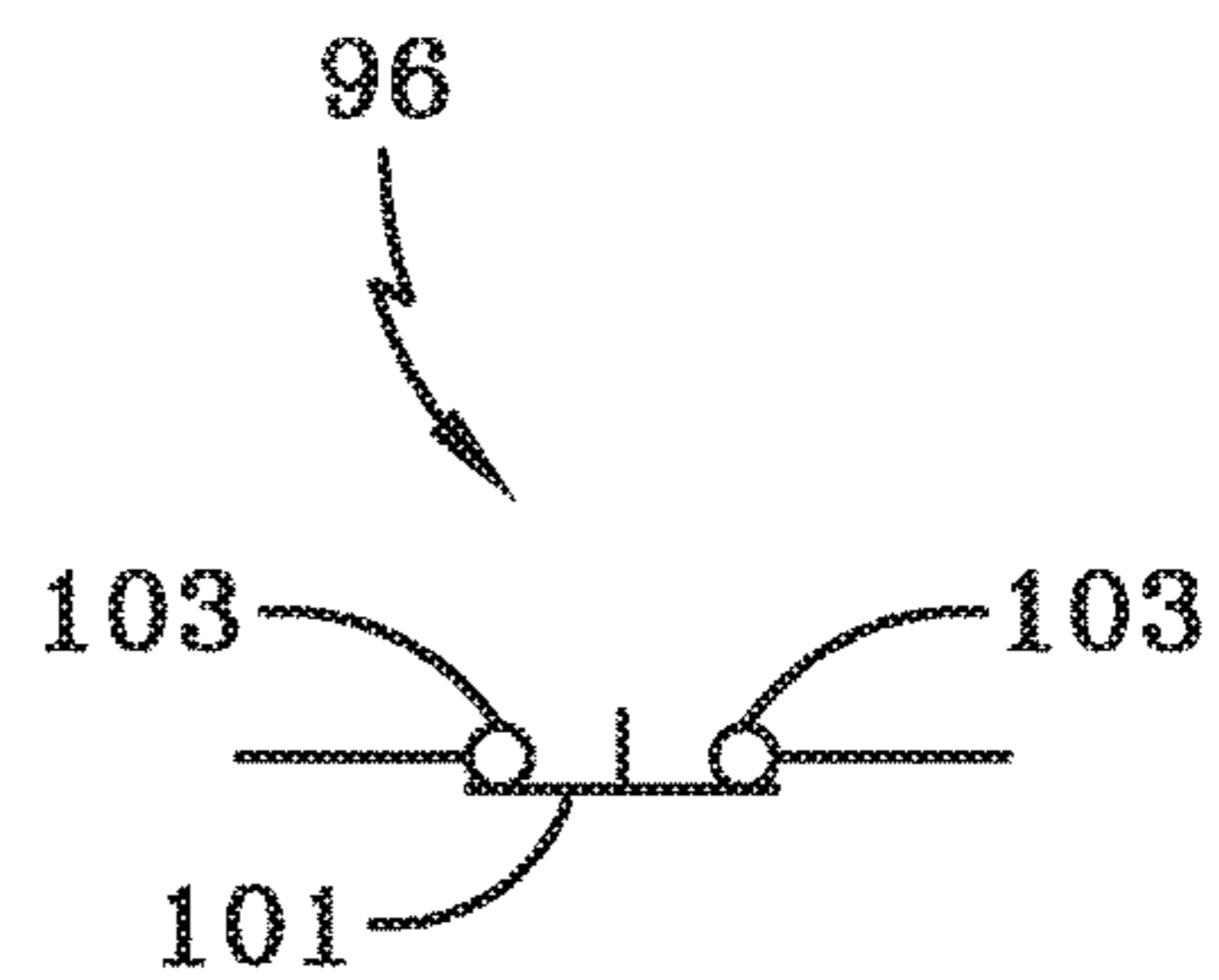

FIG-19B

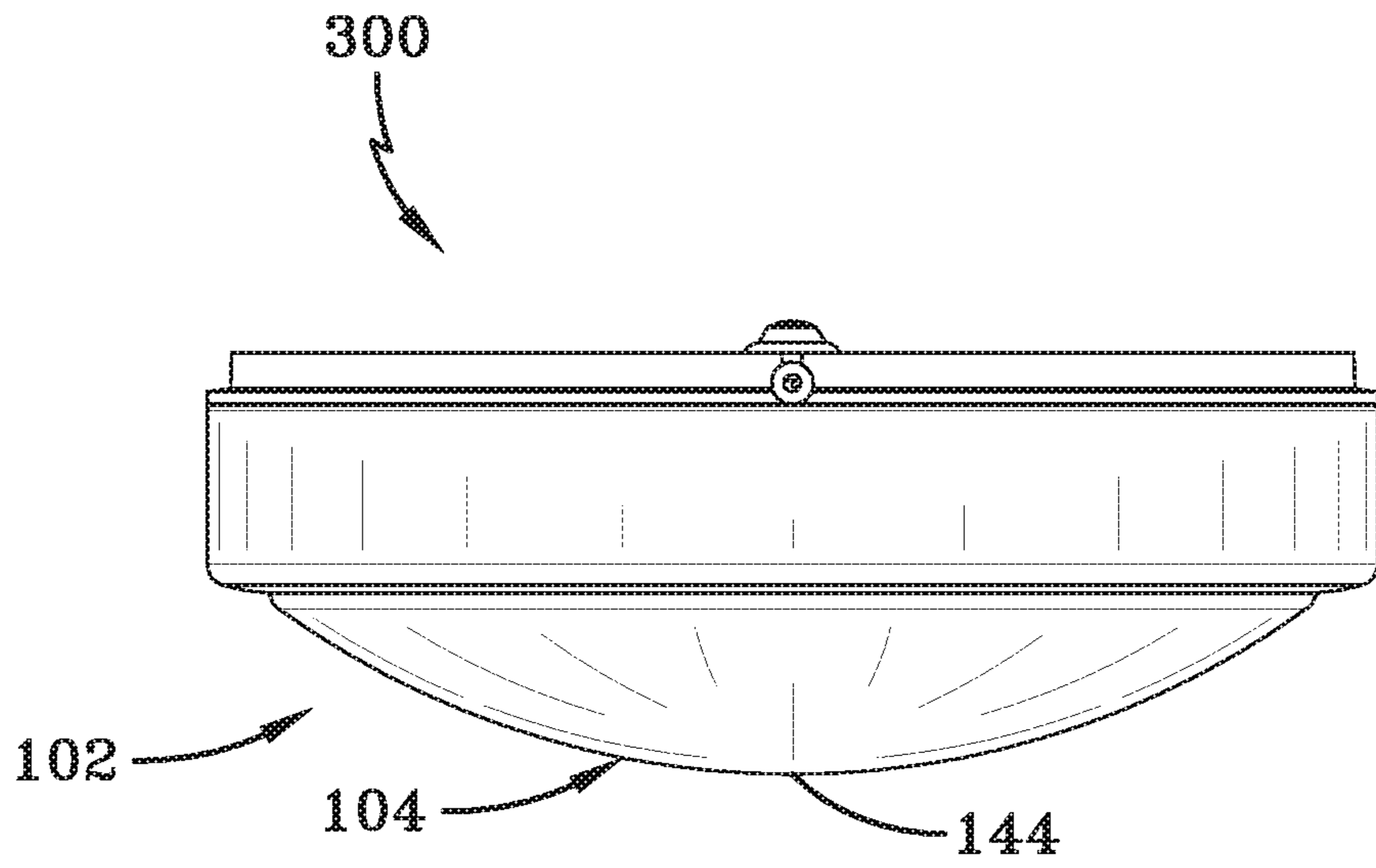

FIG-20

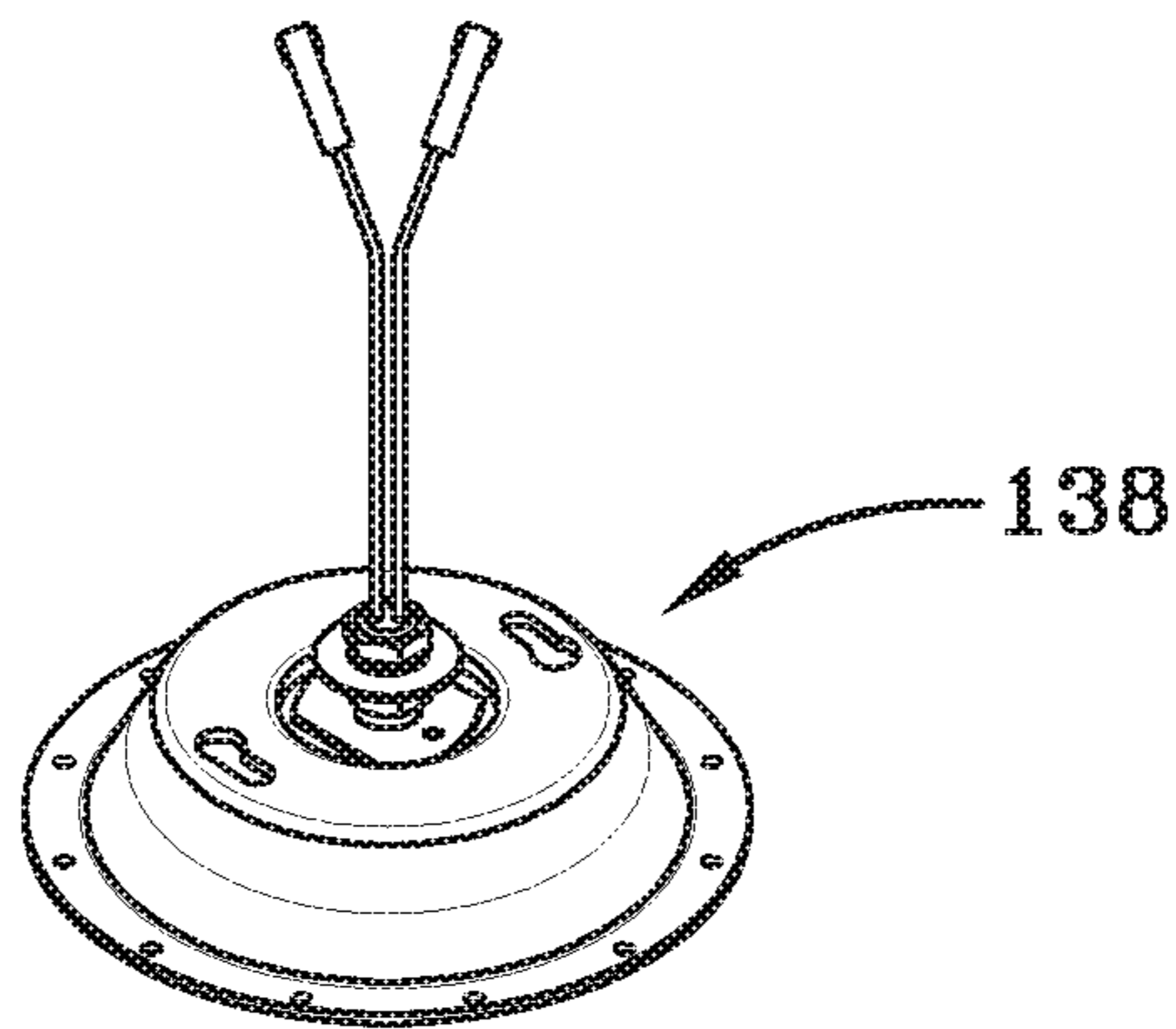

FIG-21

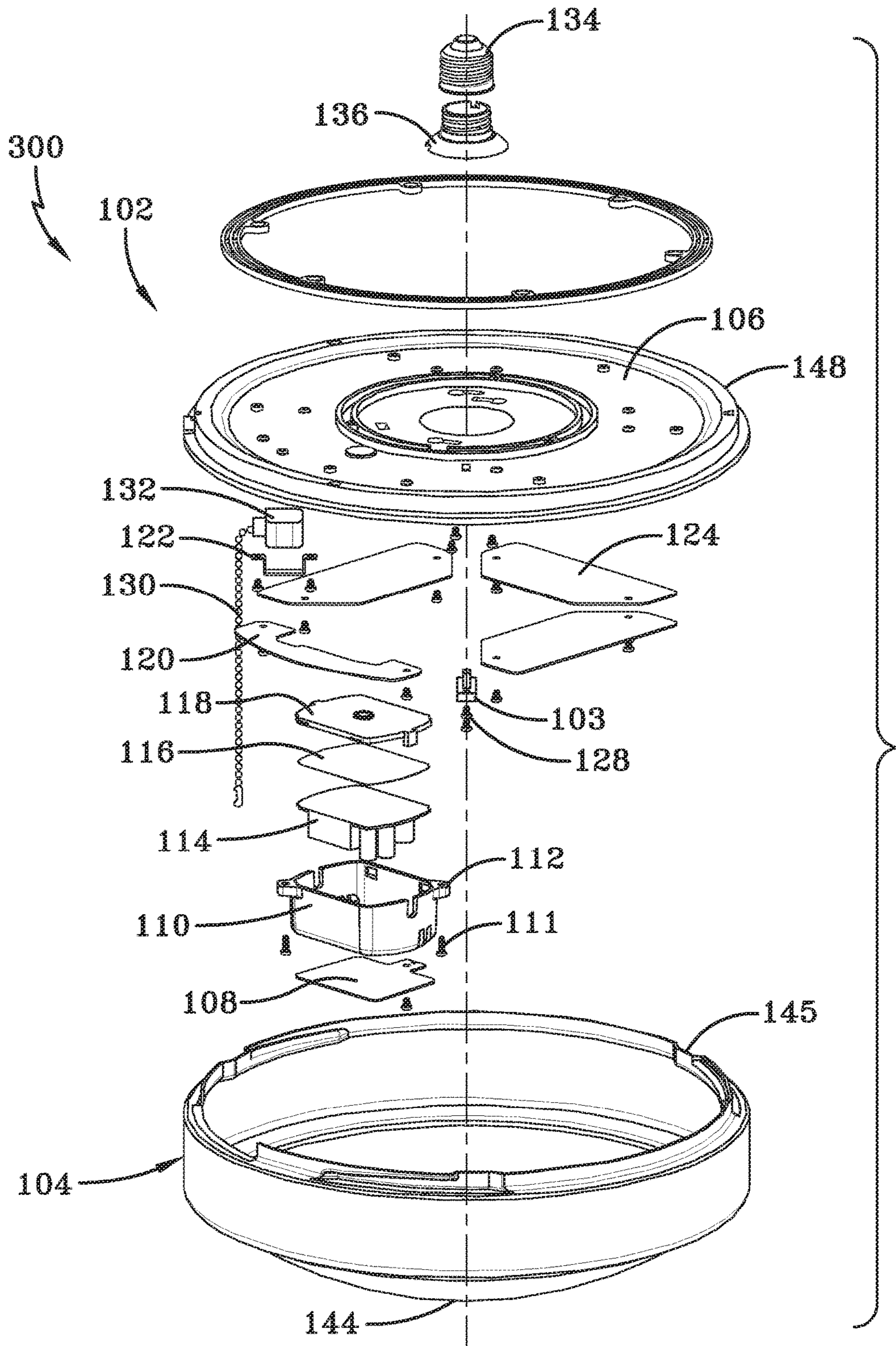

FIG-22

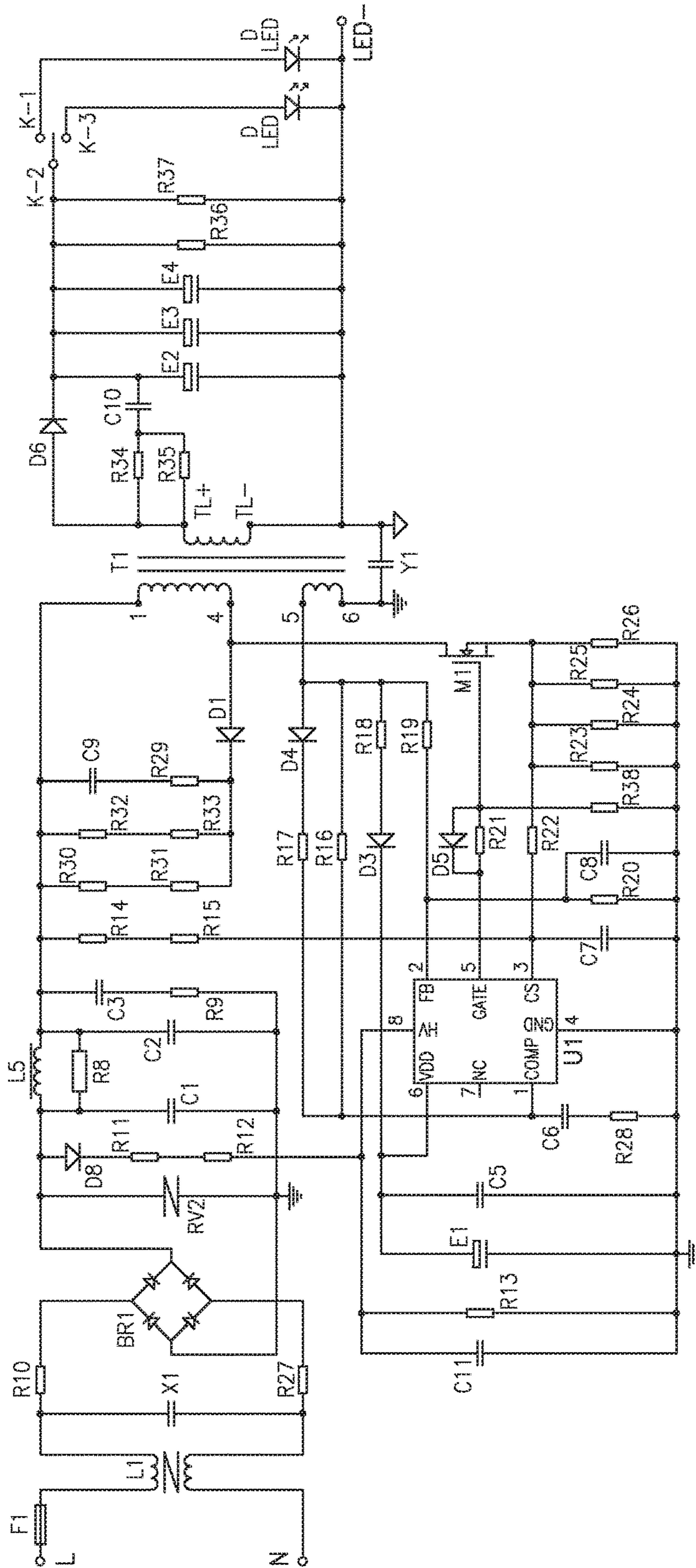

FIG-23

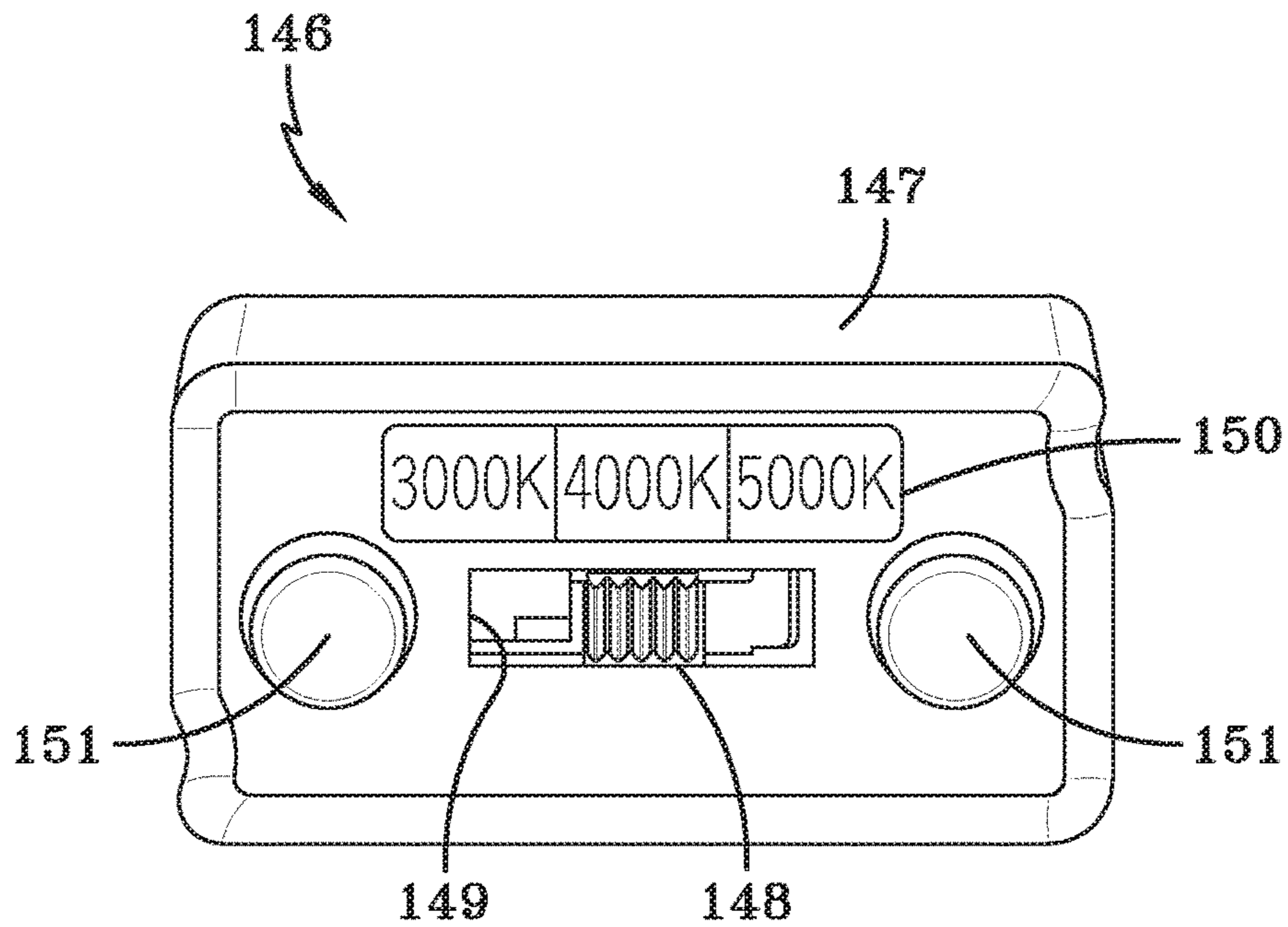

FIG-24

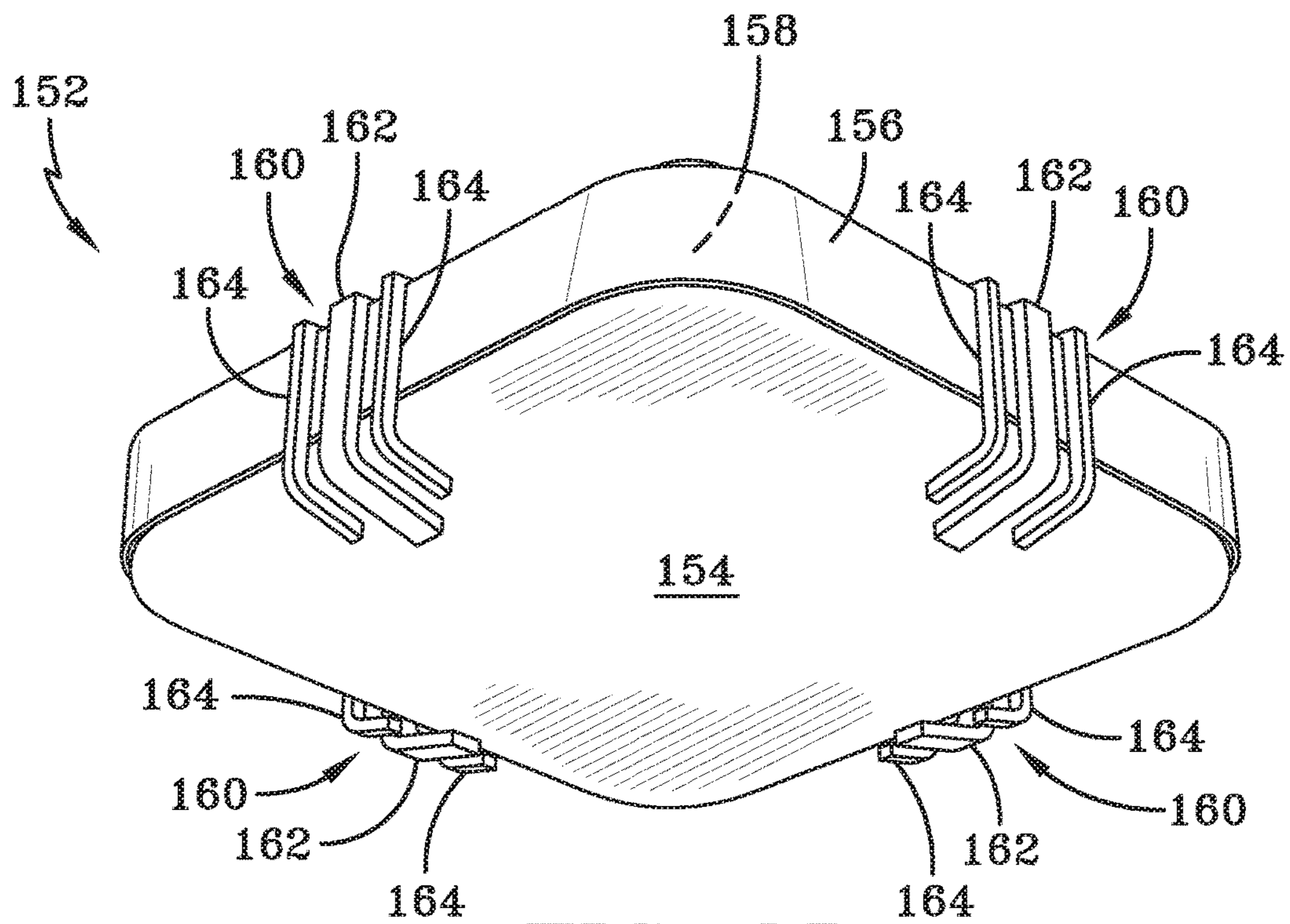

FIG-25

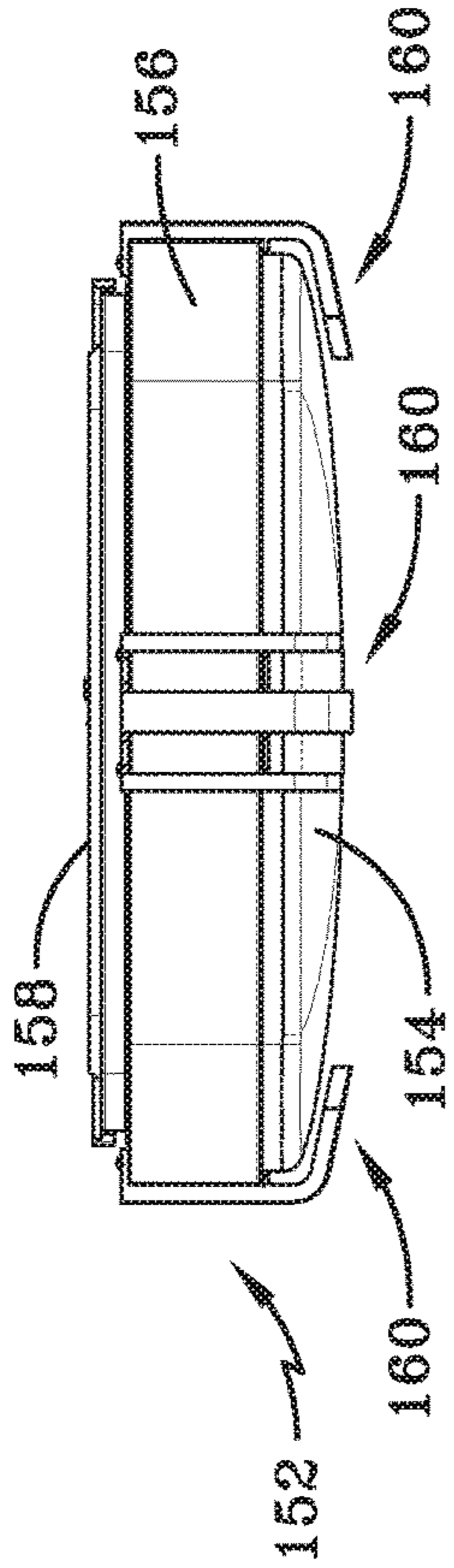

FIG-27

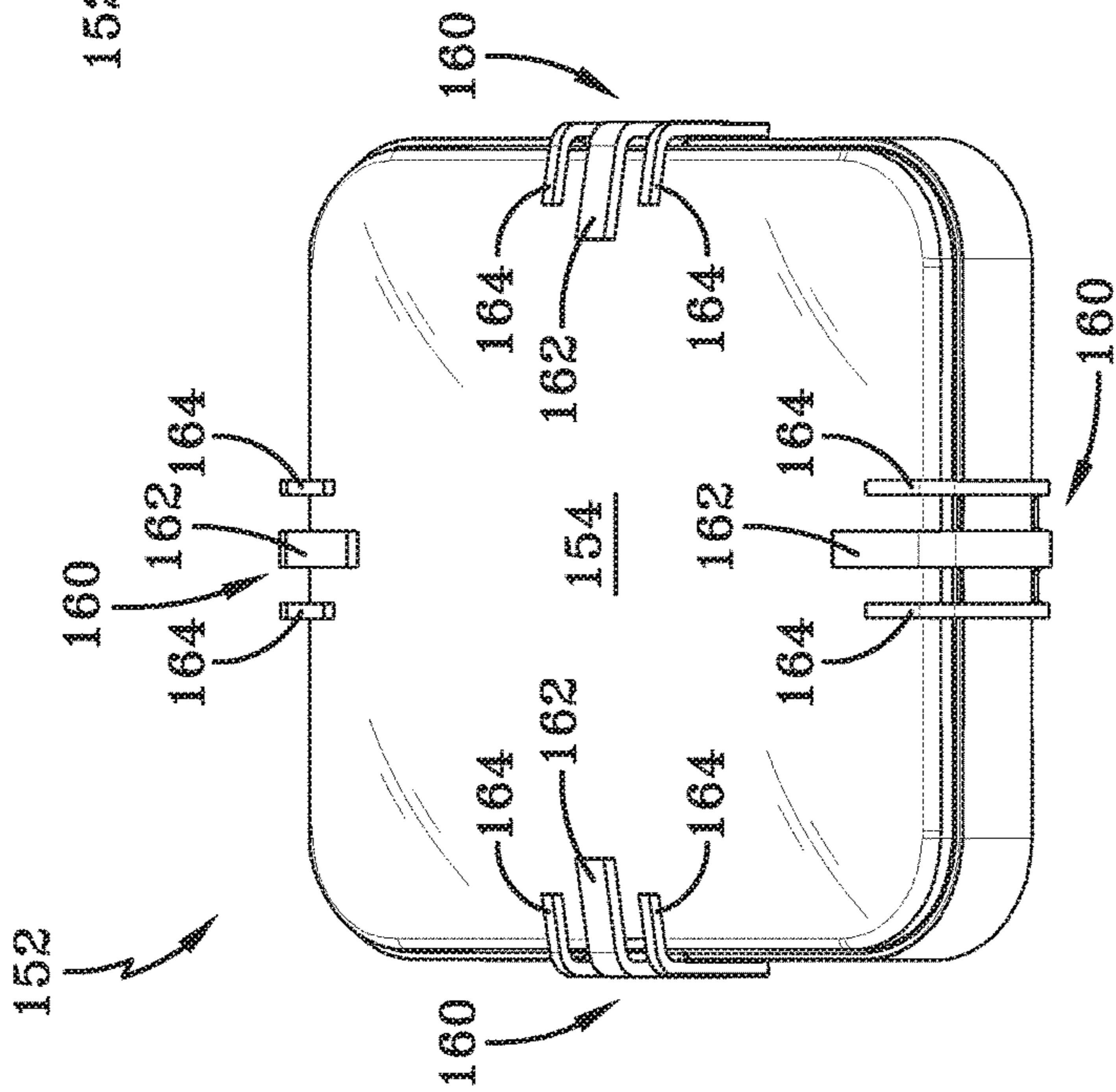

FIG-26

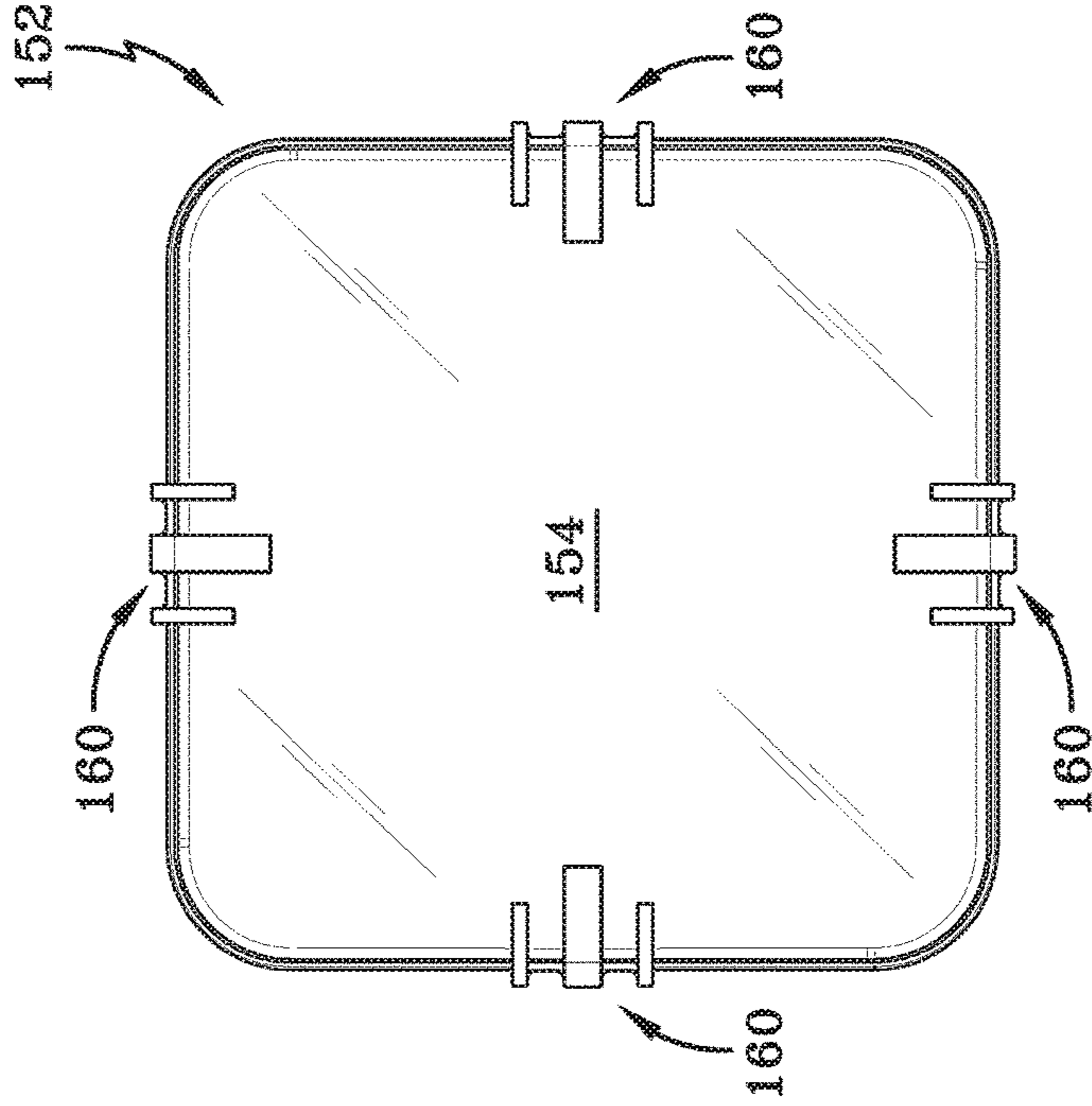

FIG-28

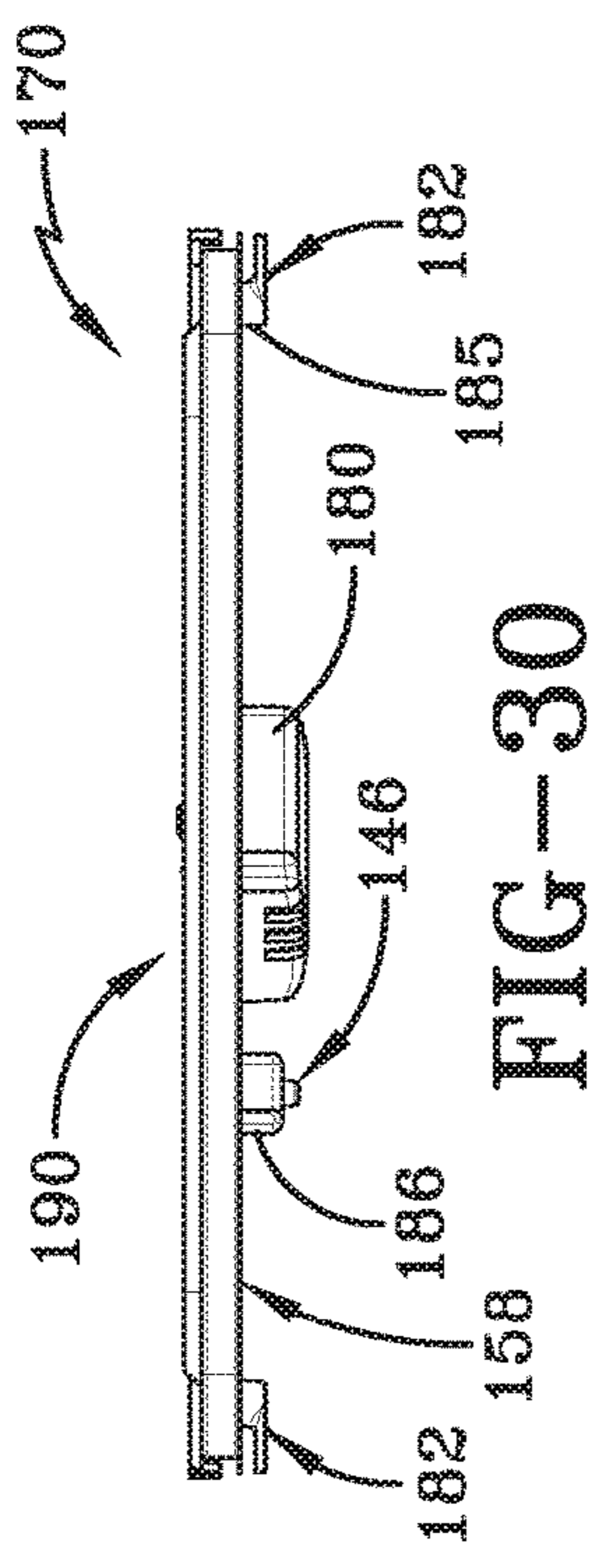

FIG-30

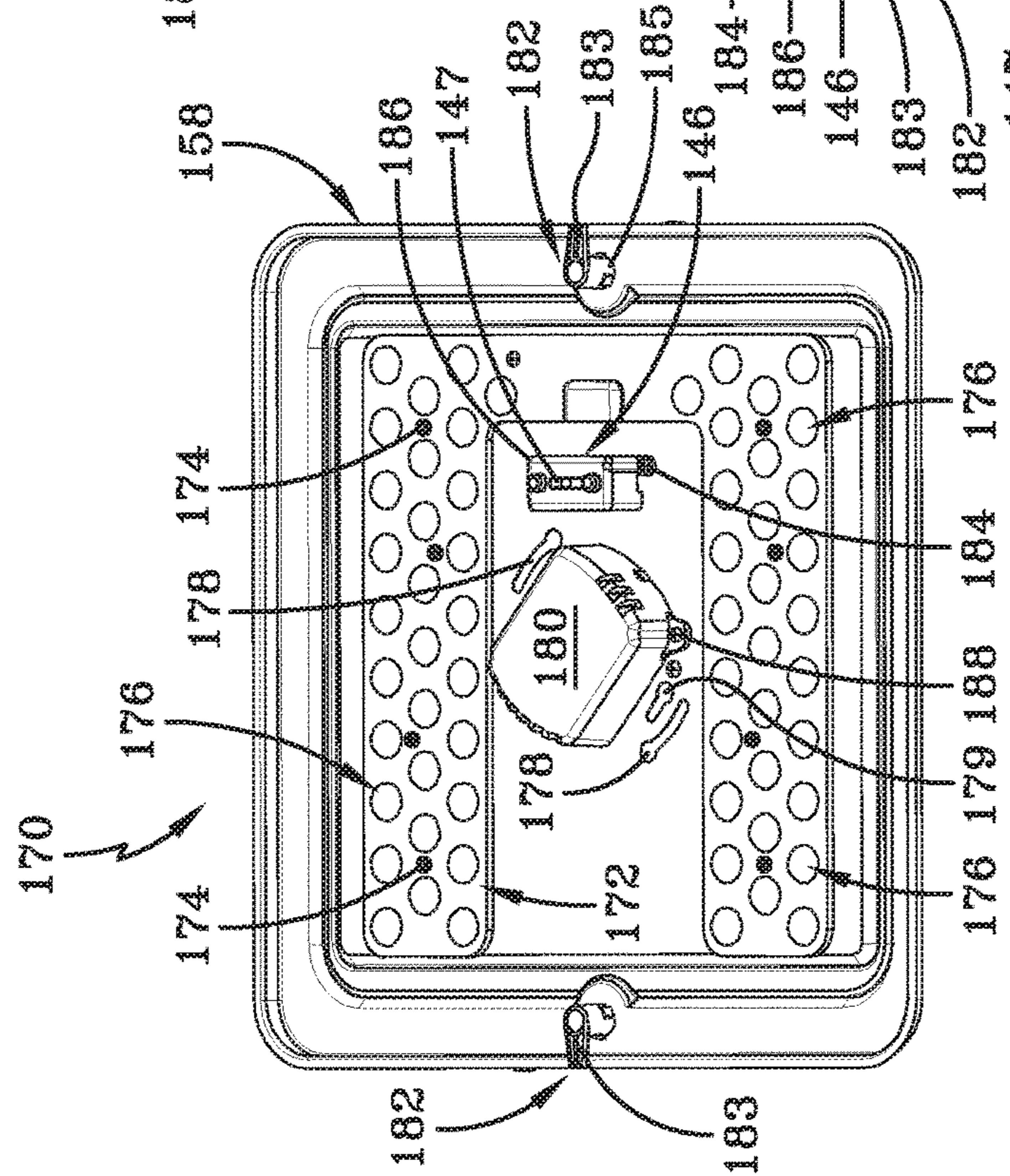

FIG-29

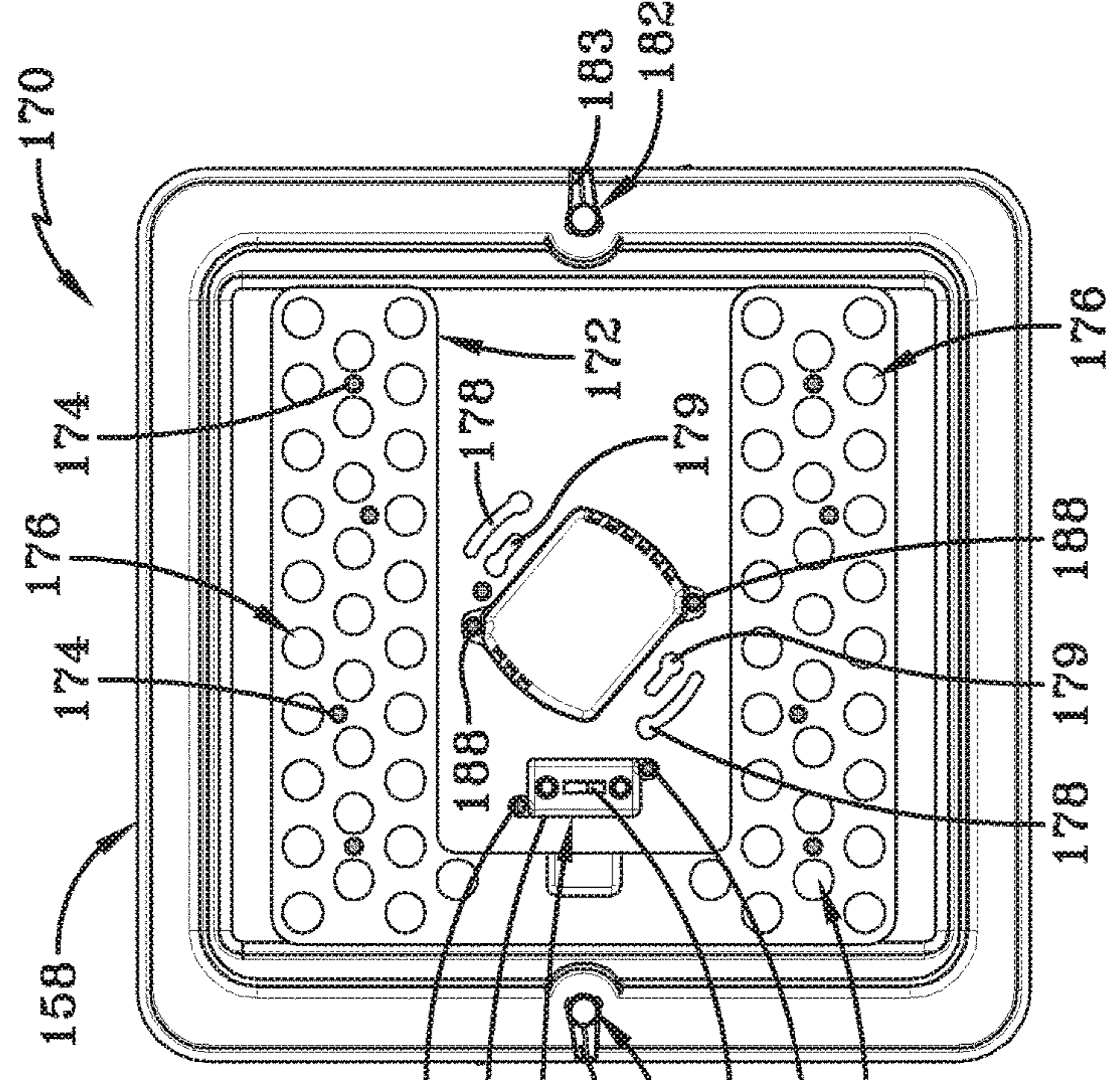

FIG-31

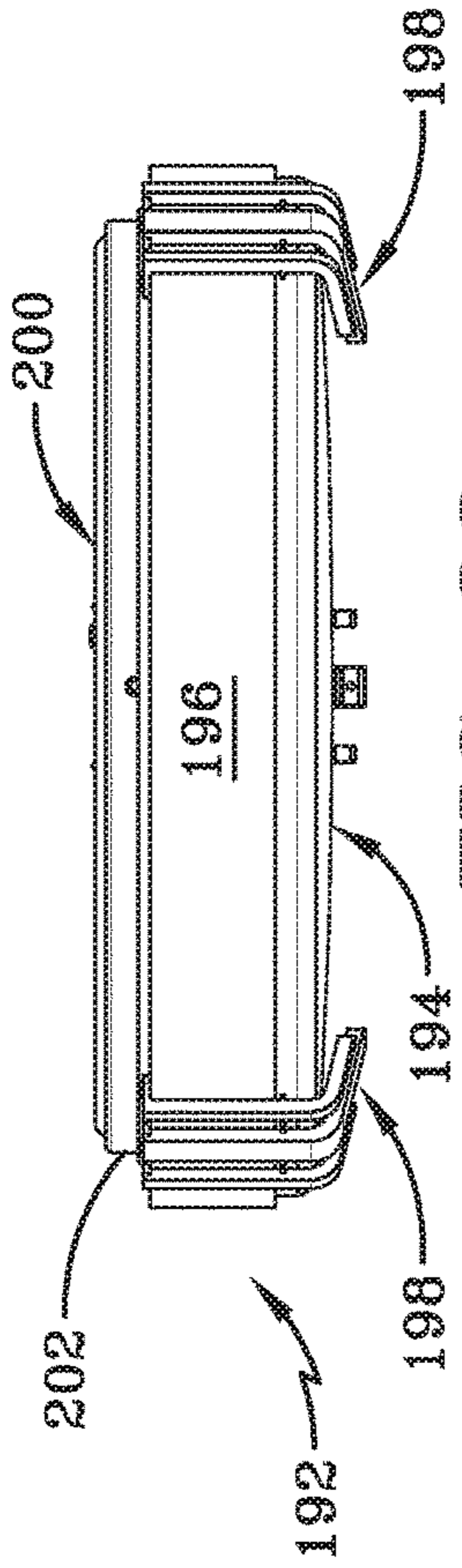

FIG-33

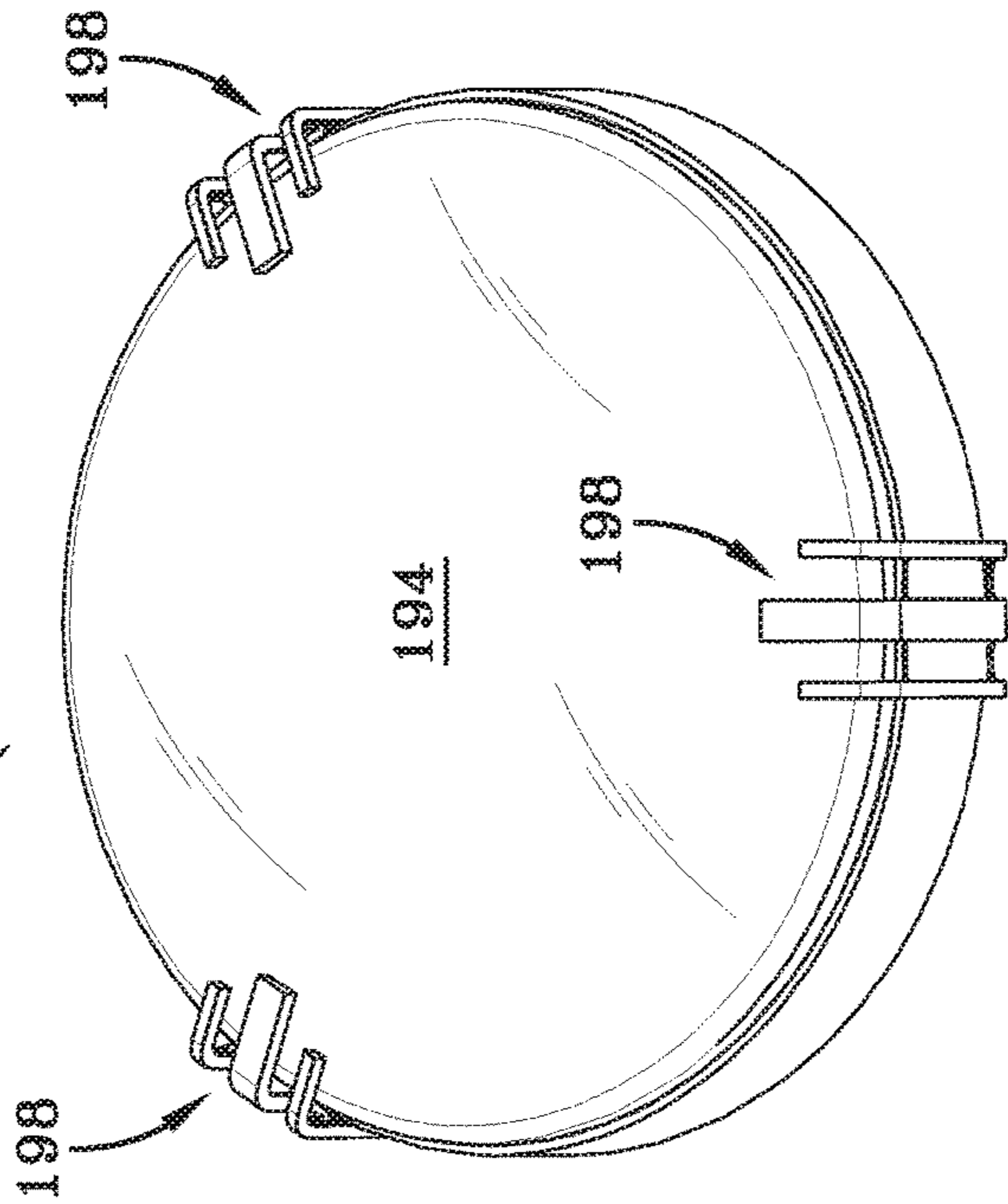

FIG-32

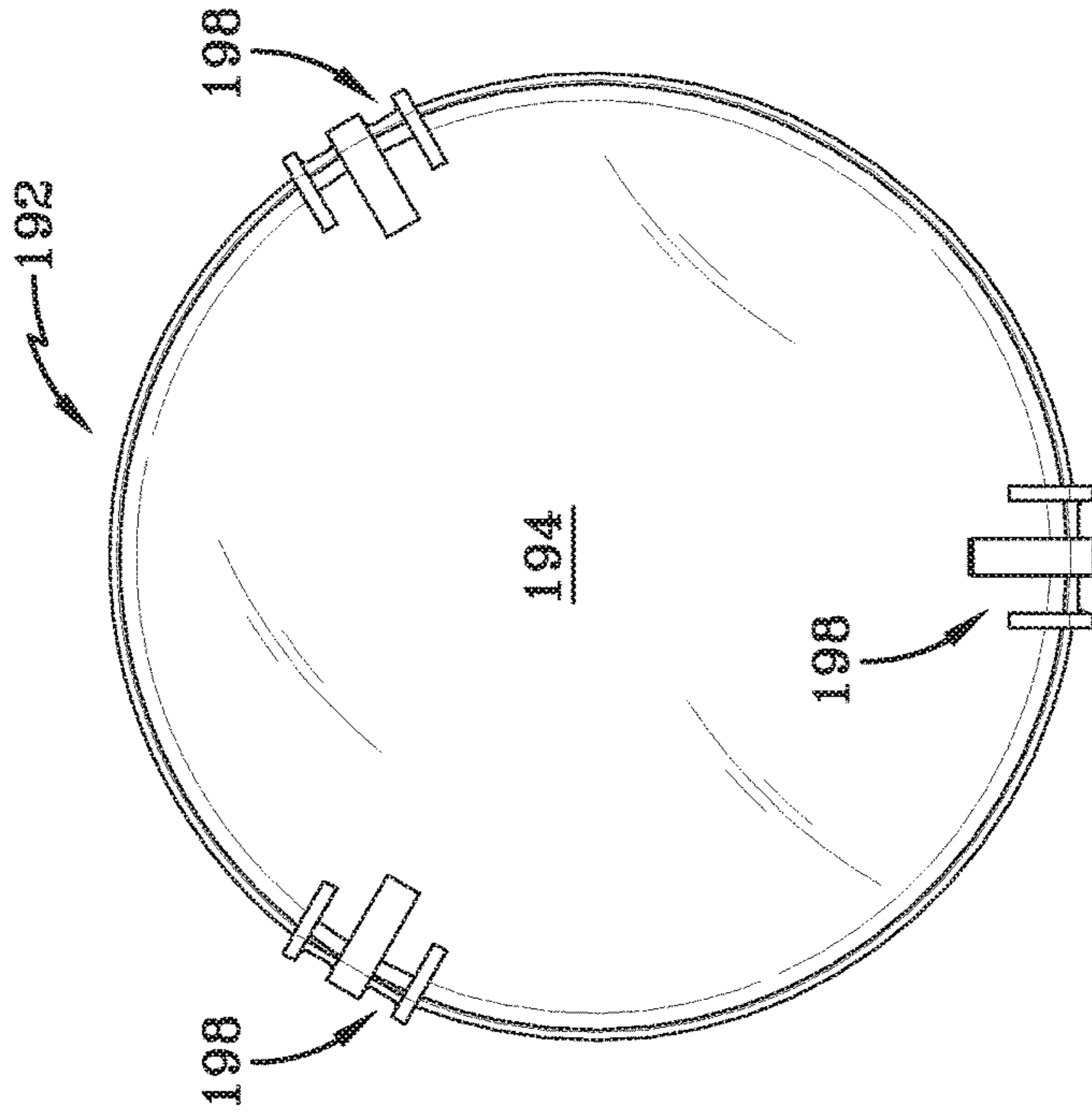

FIG-34

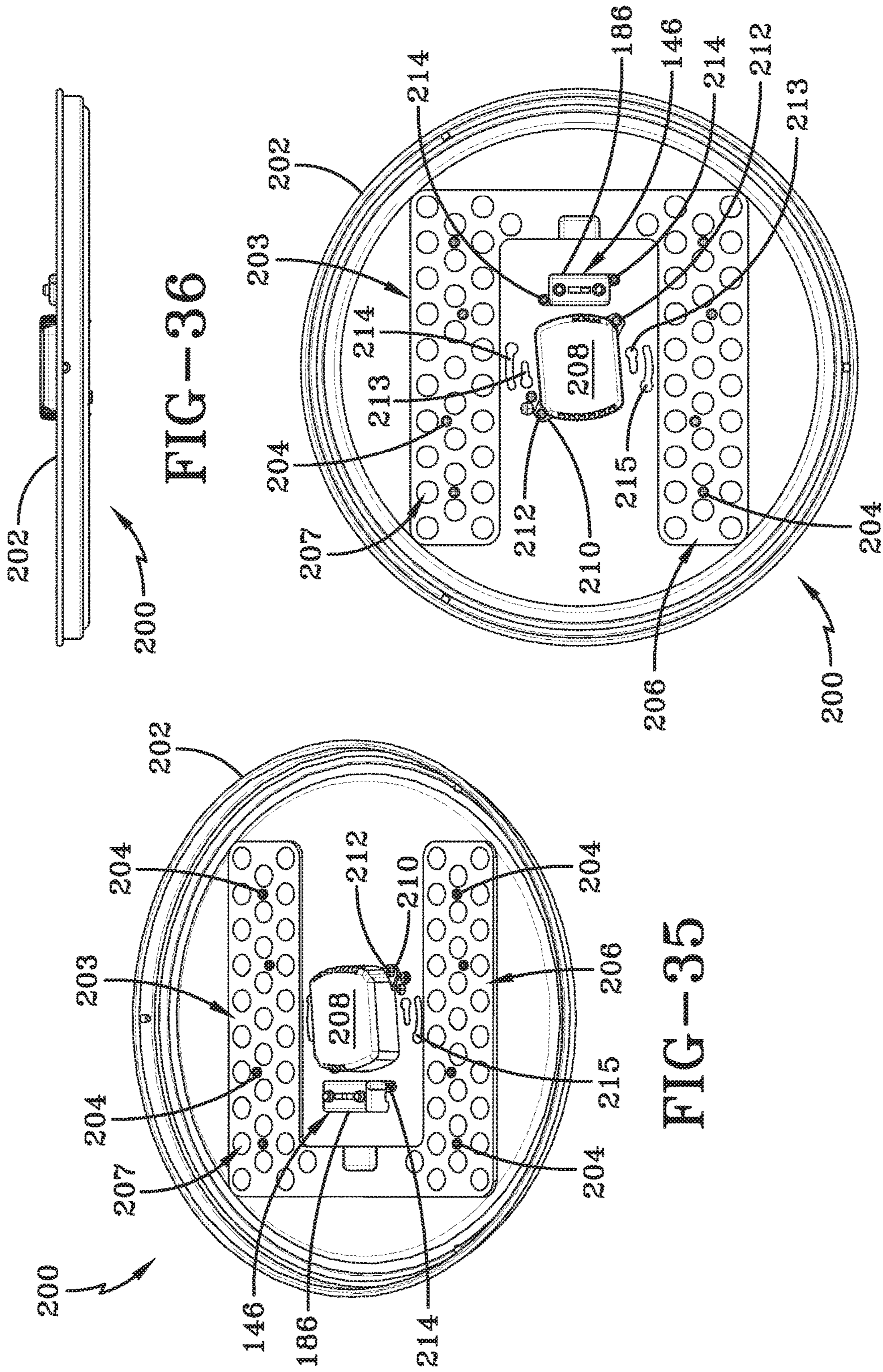

FIG-36

FIG-37

FIG-35

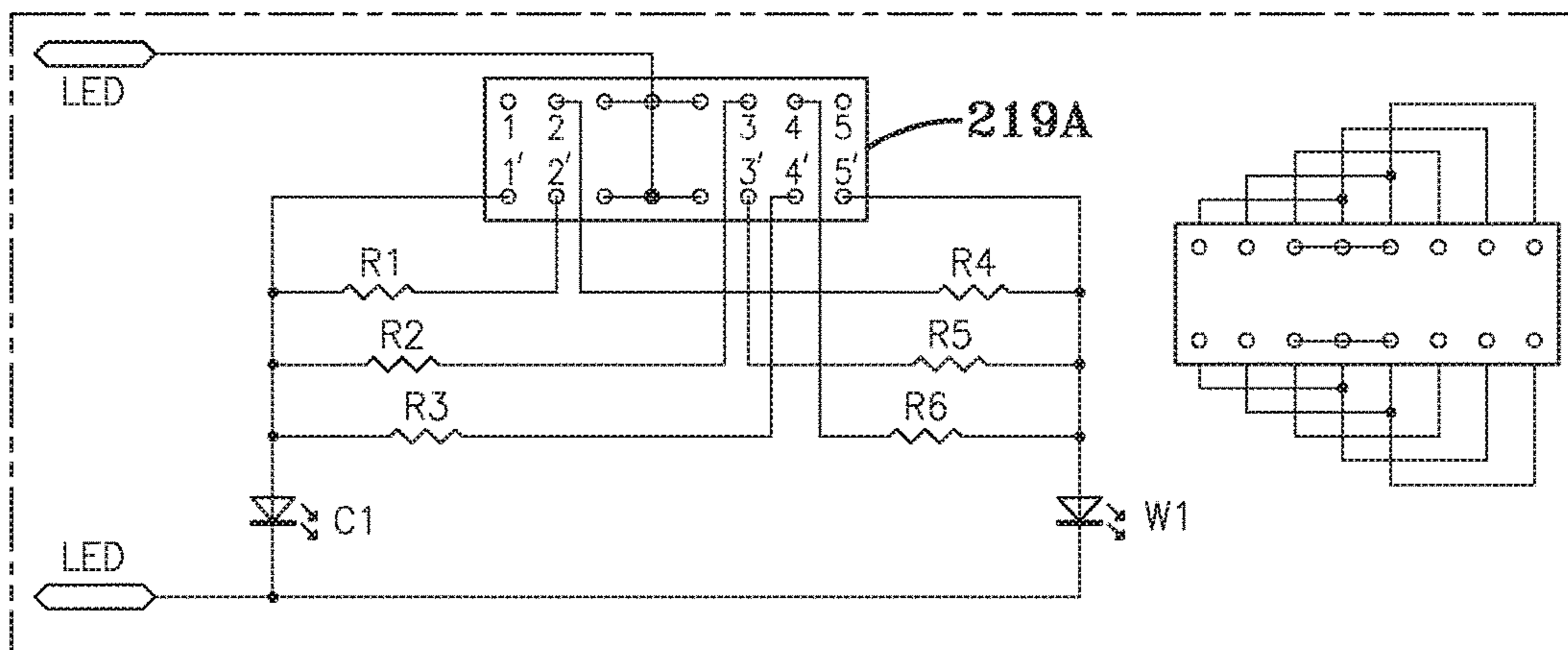

FIG-38A

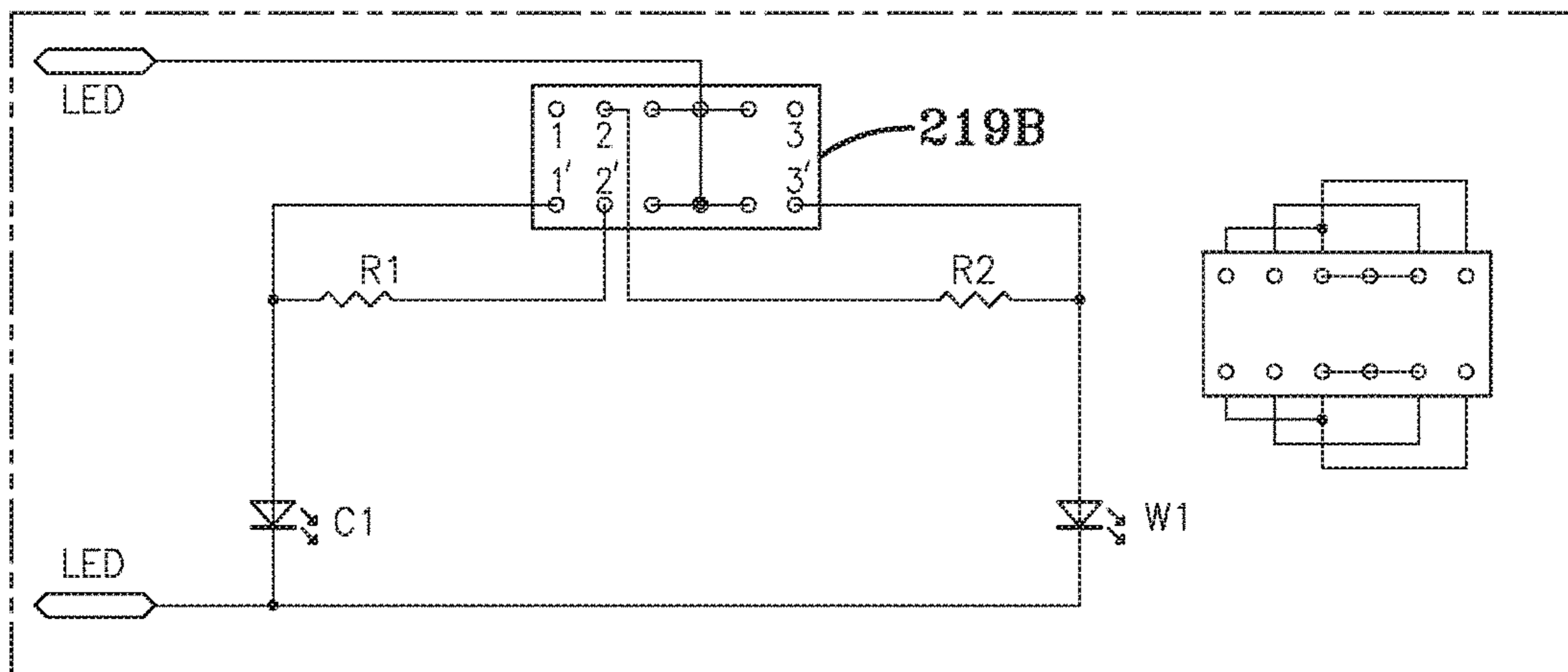

FIG-38B

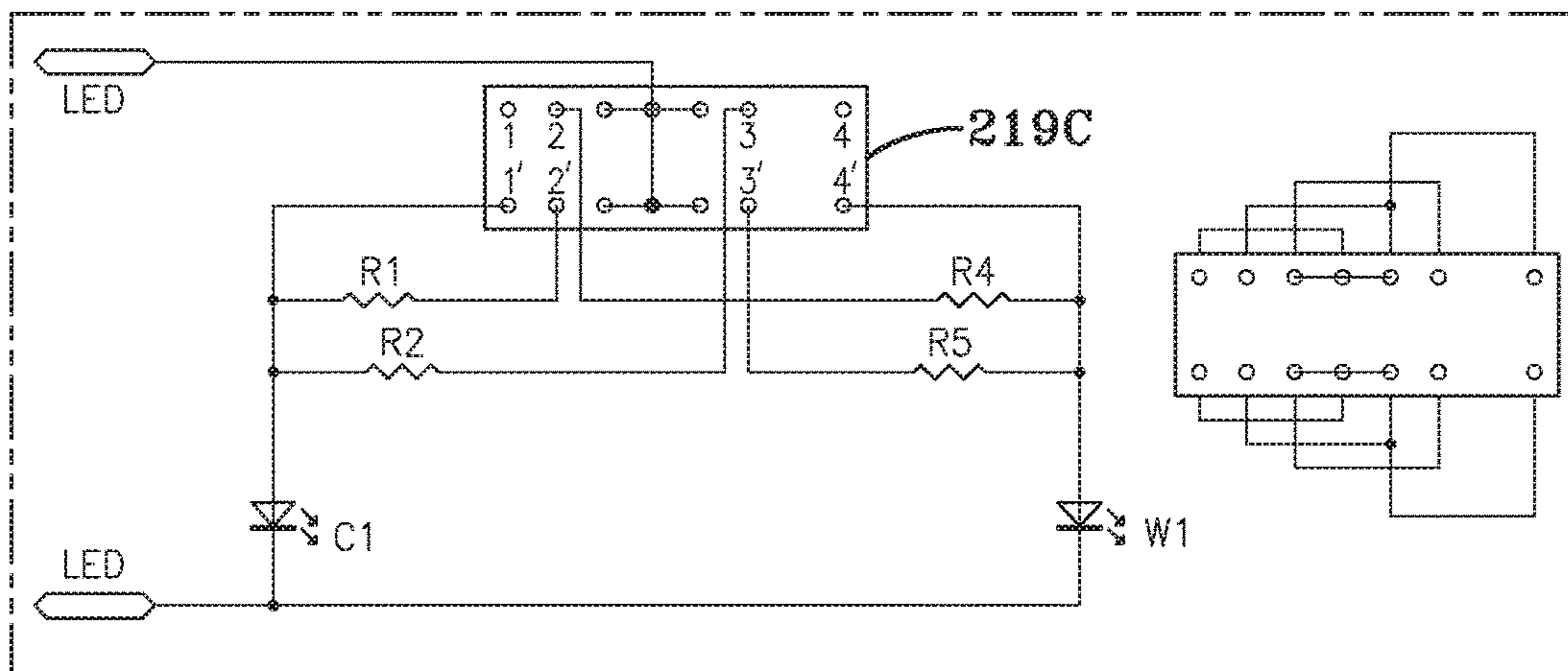

FIG-38C

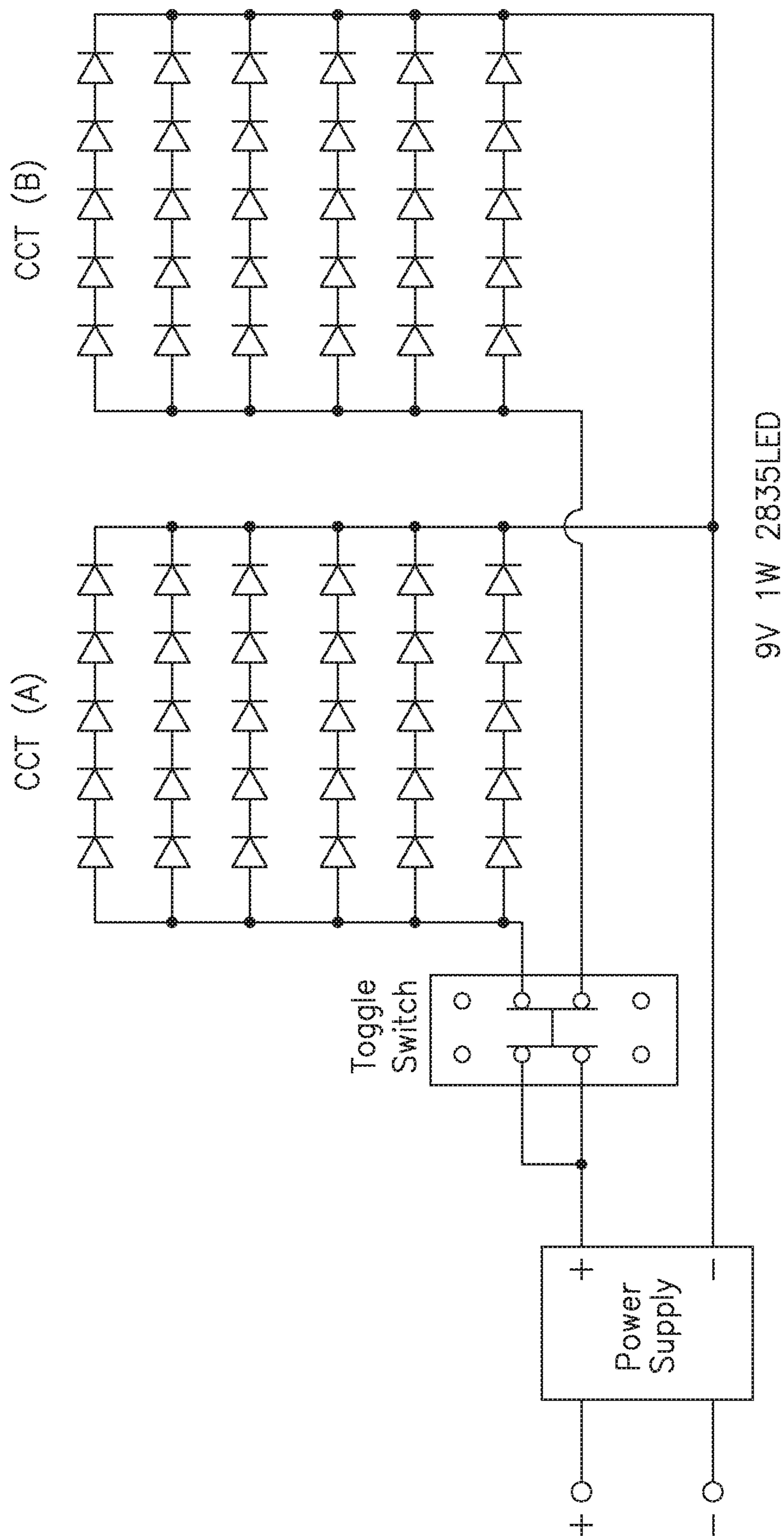

FIG--38D

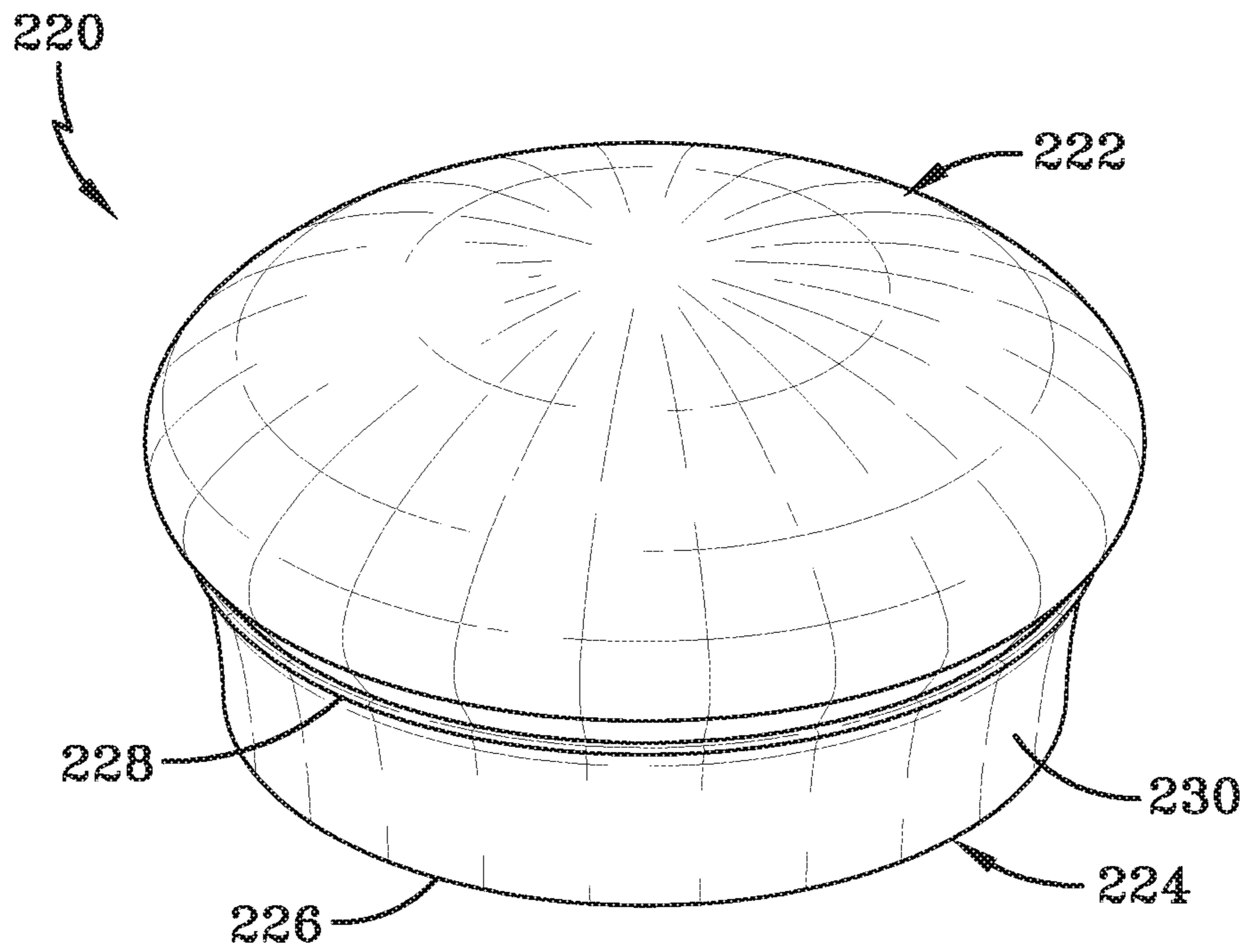

FIG-39

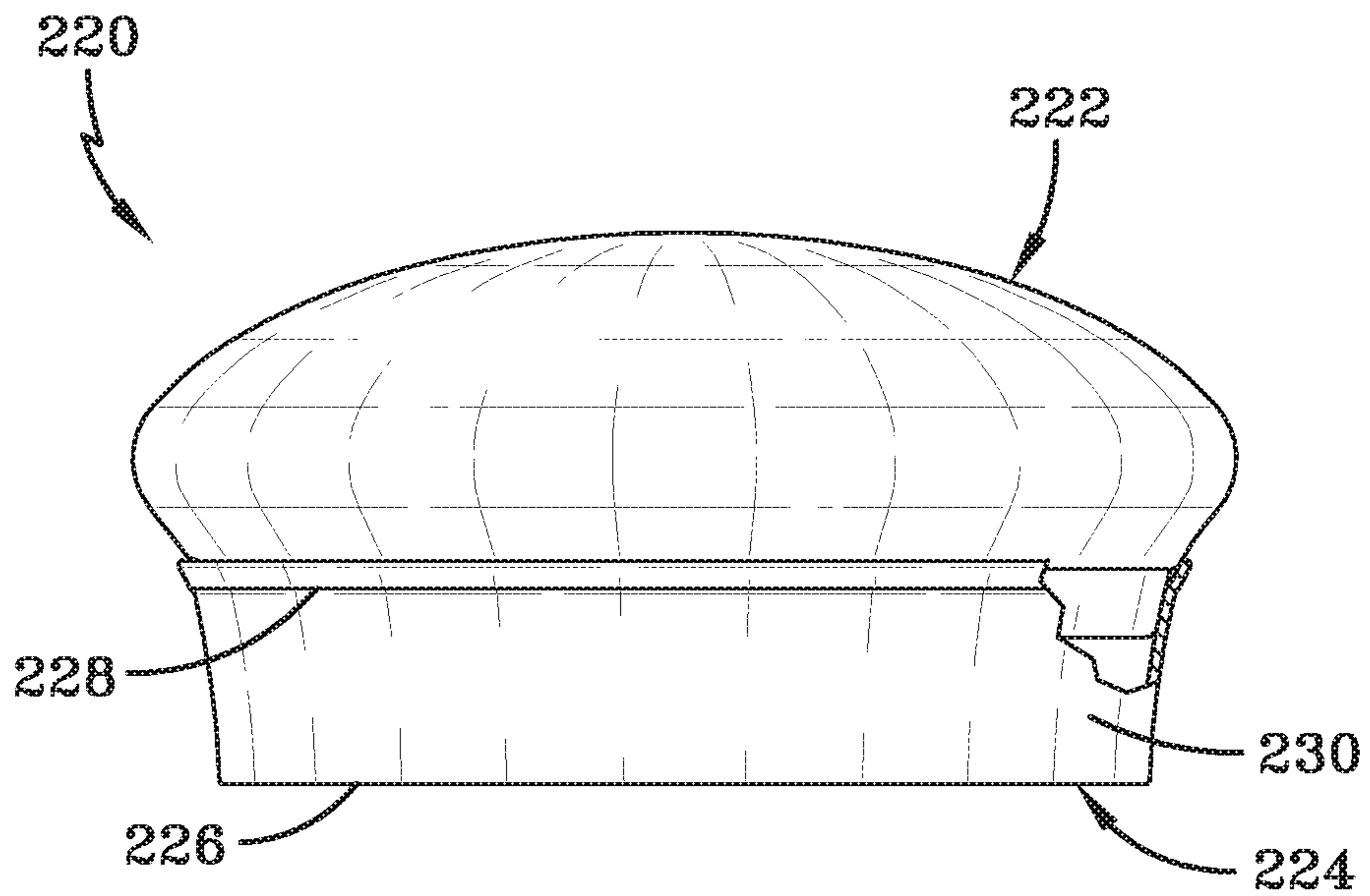

FIG-40

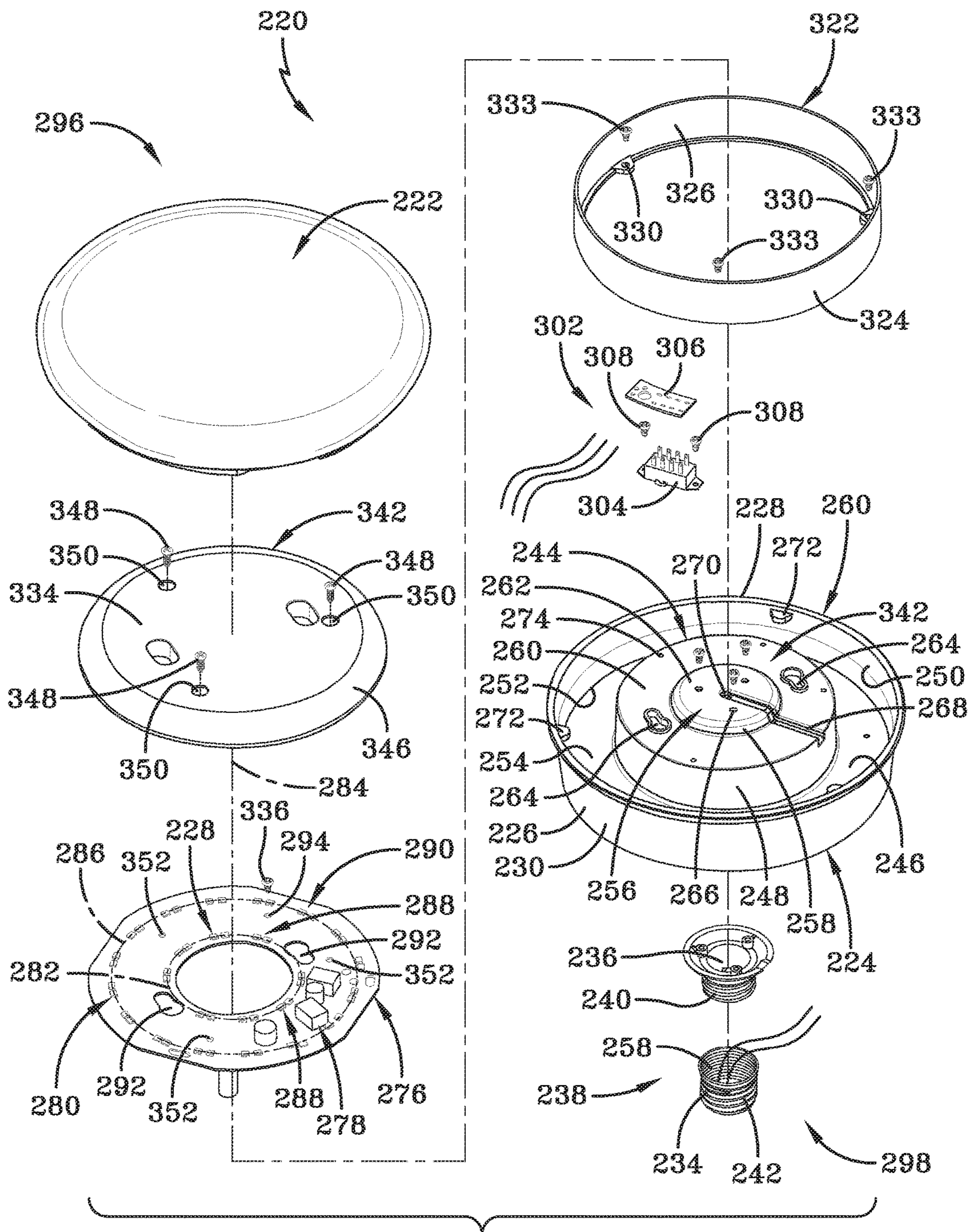

FIG-41

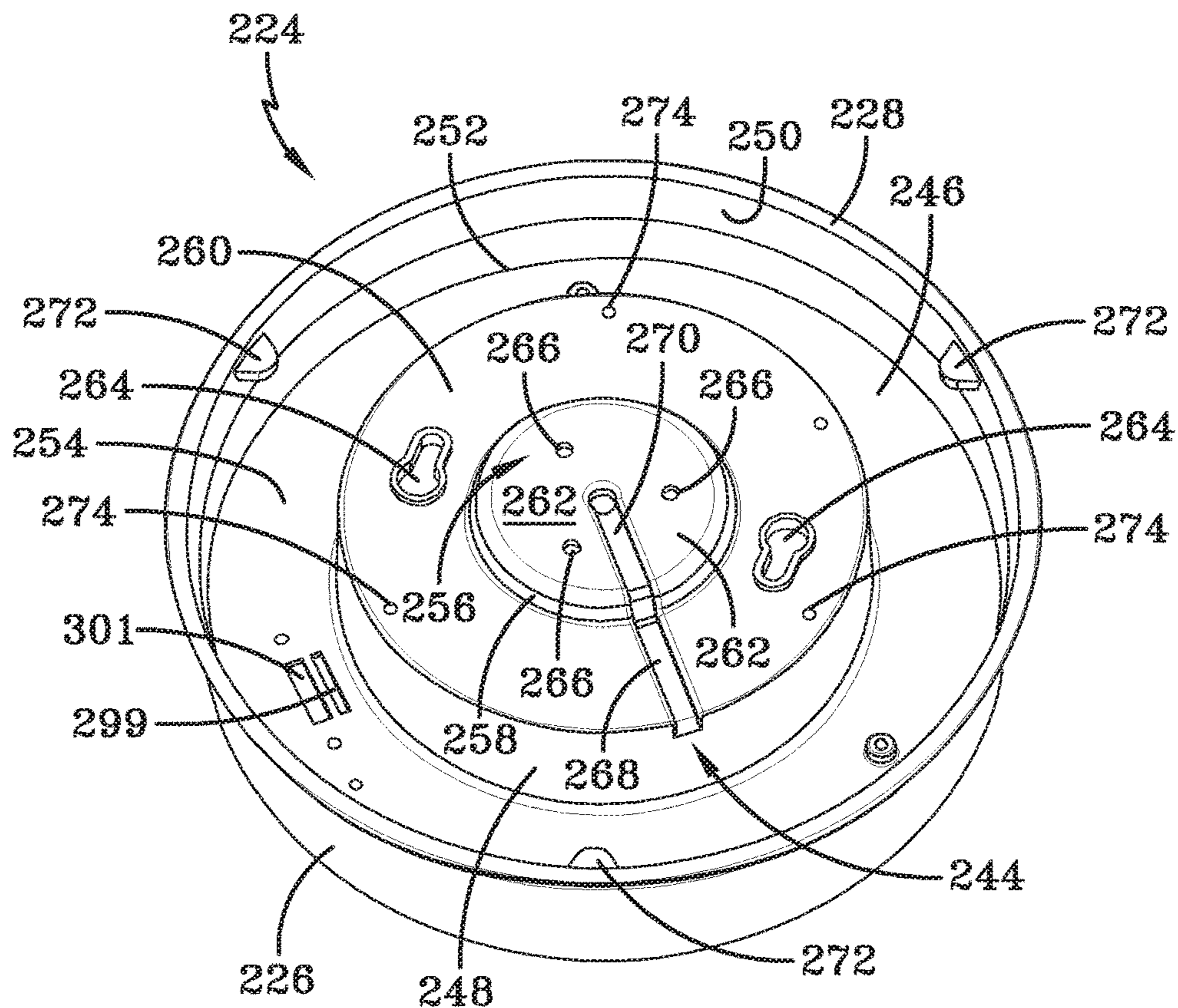

FIG-42

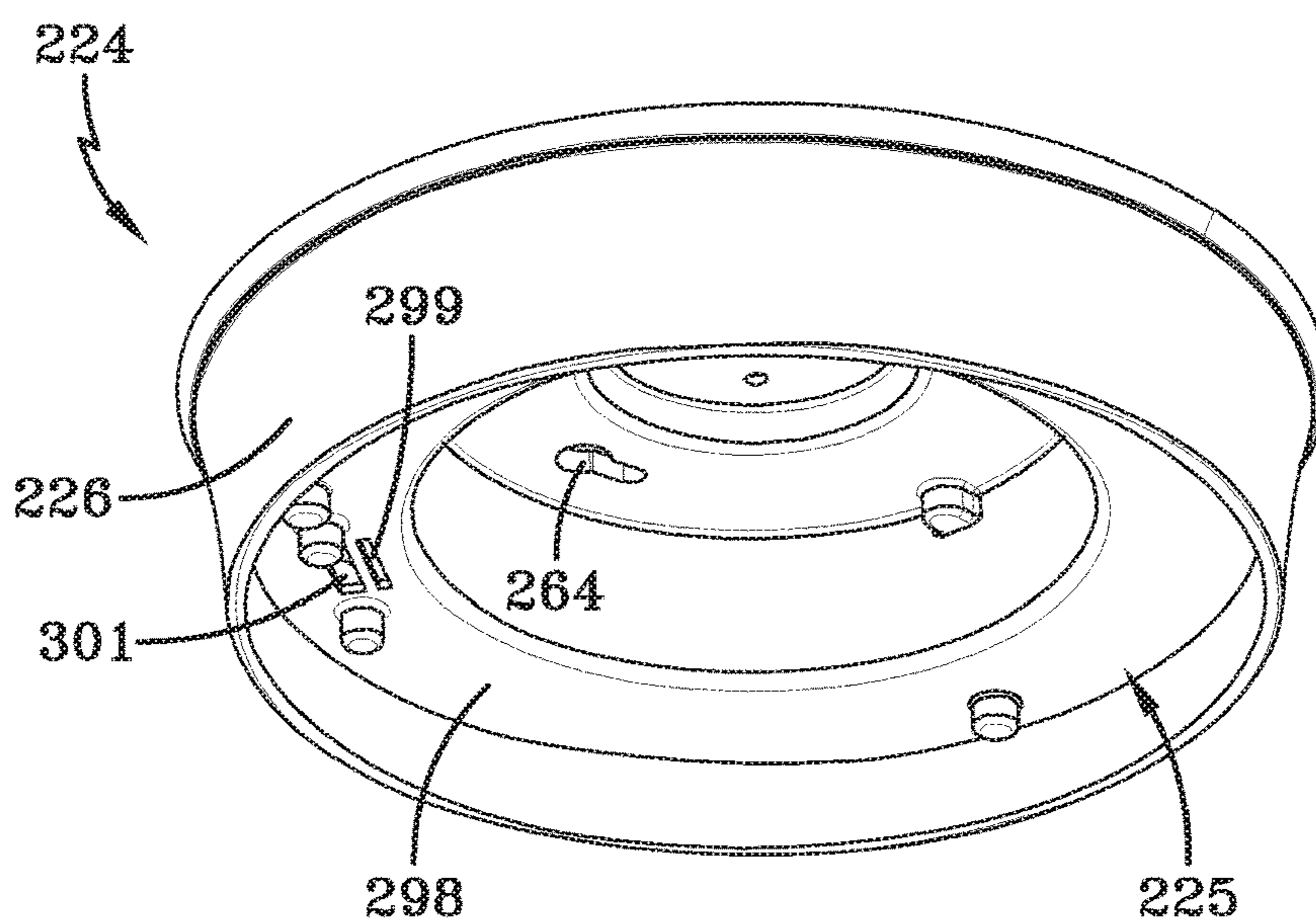

FIG-43

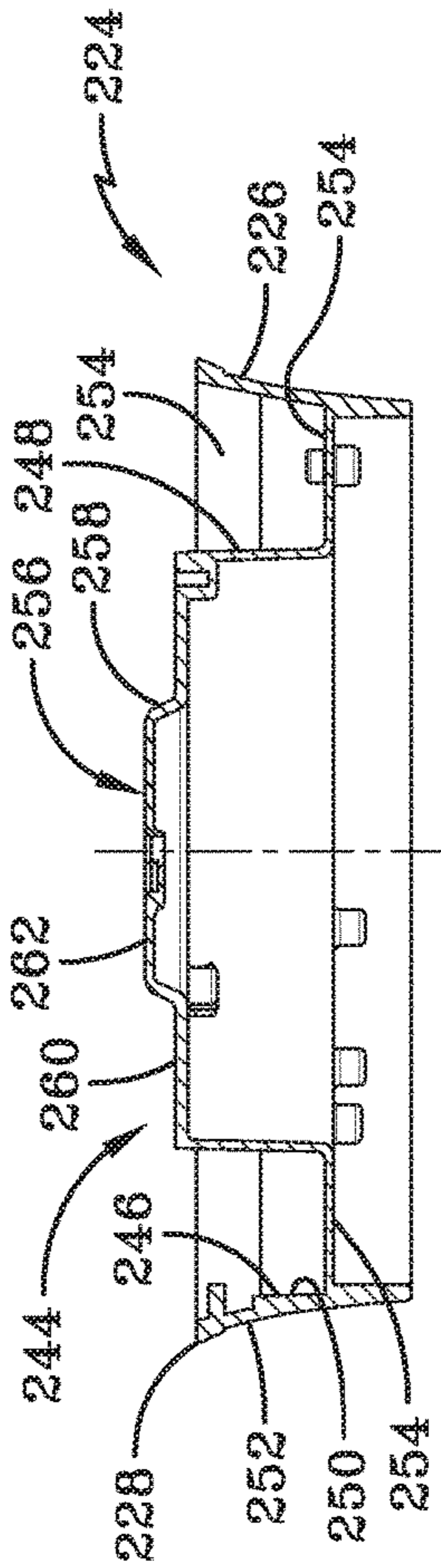

FIG-45

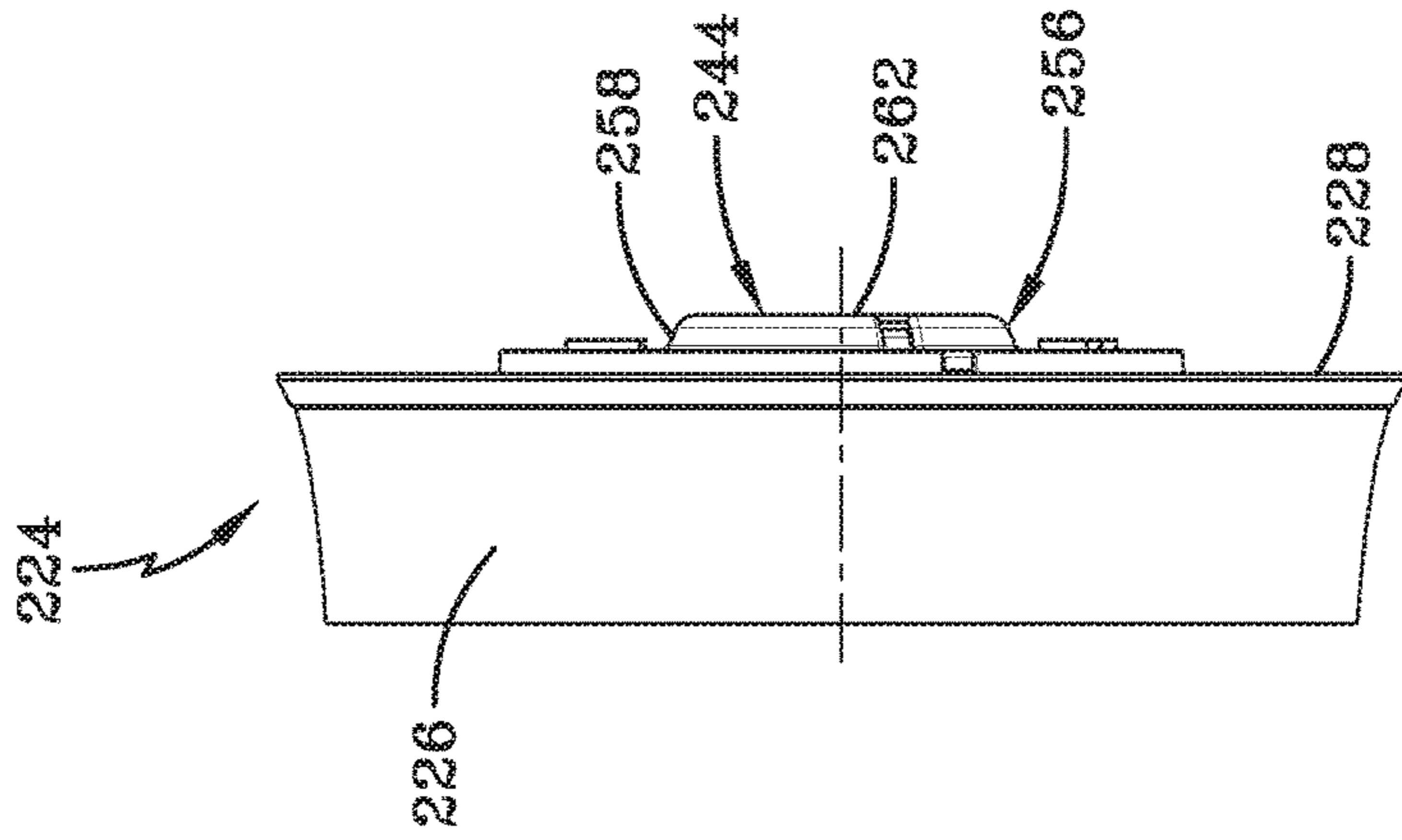

FIG-46

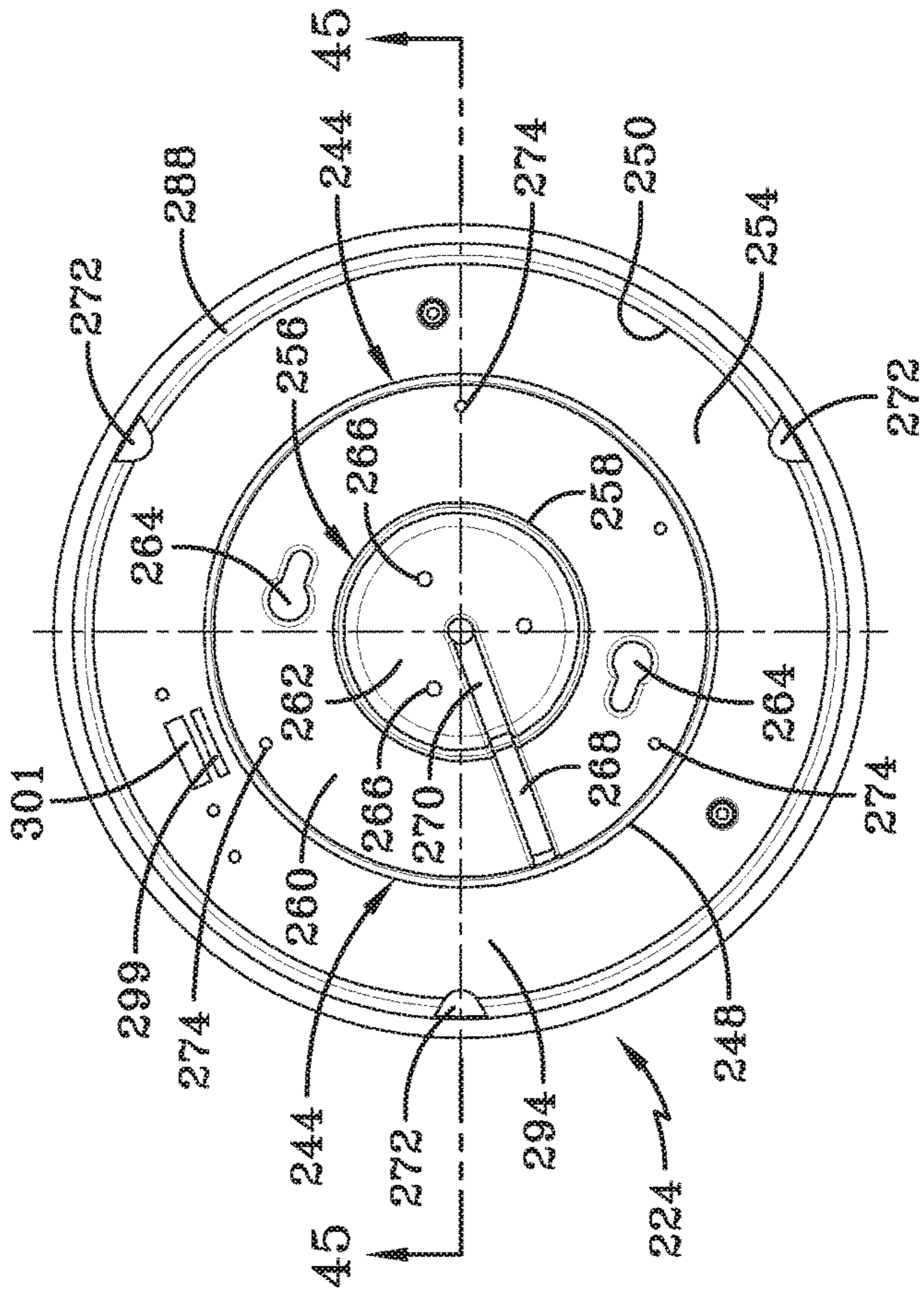

FIG-44

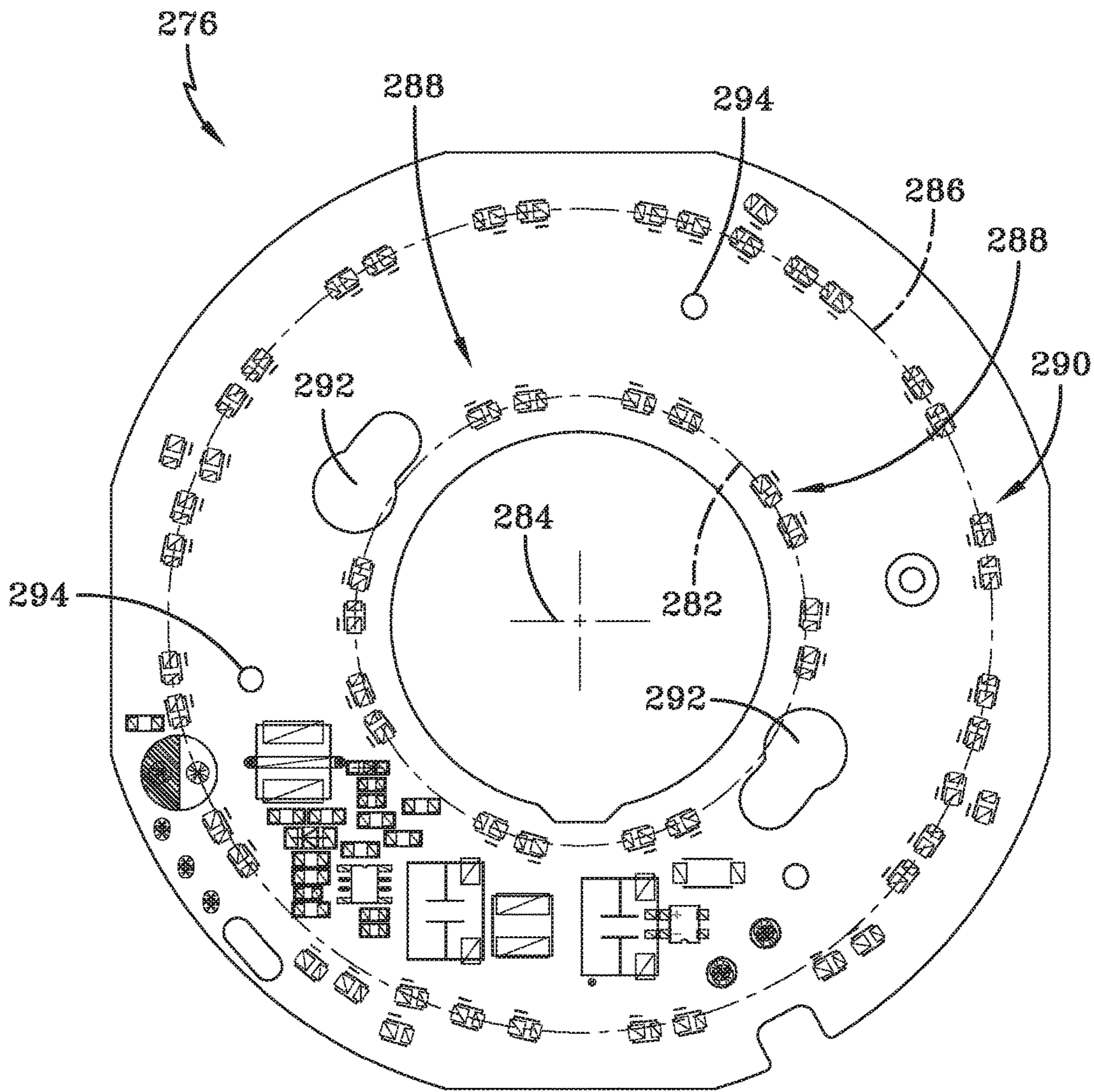
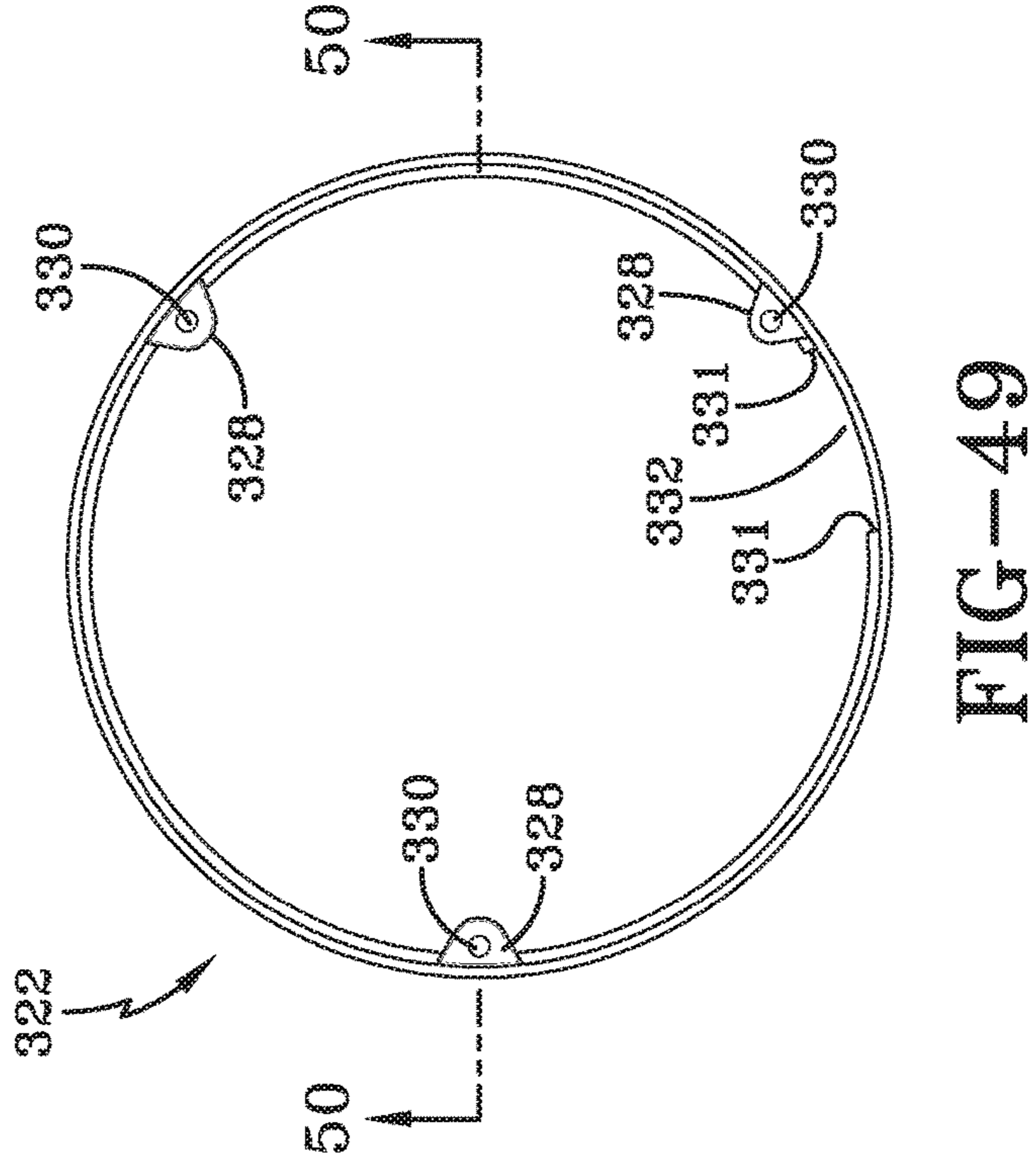
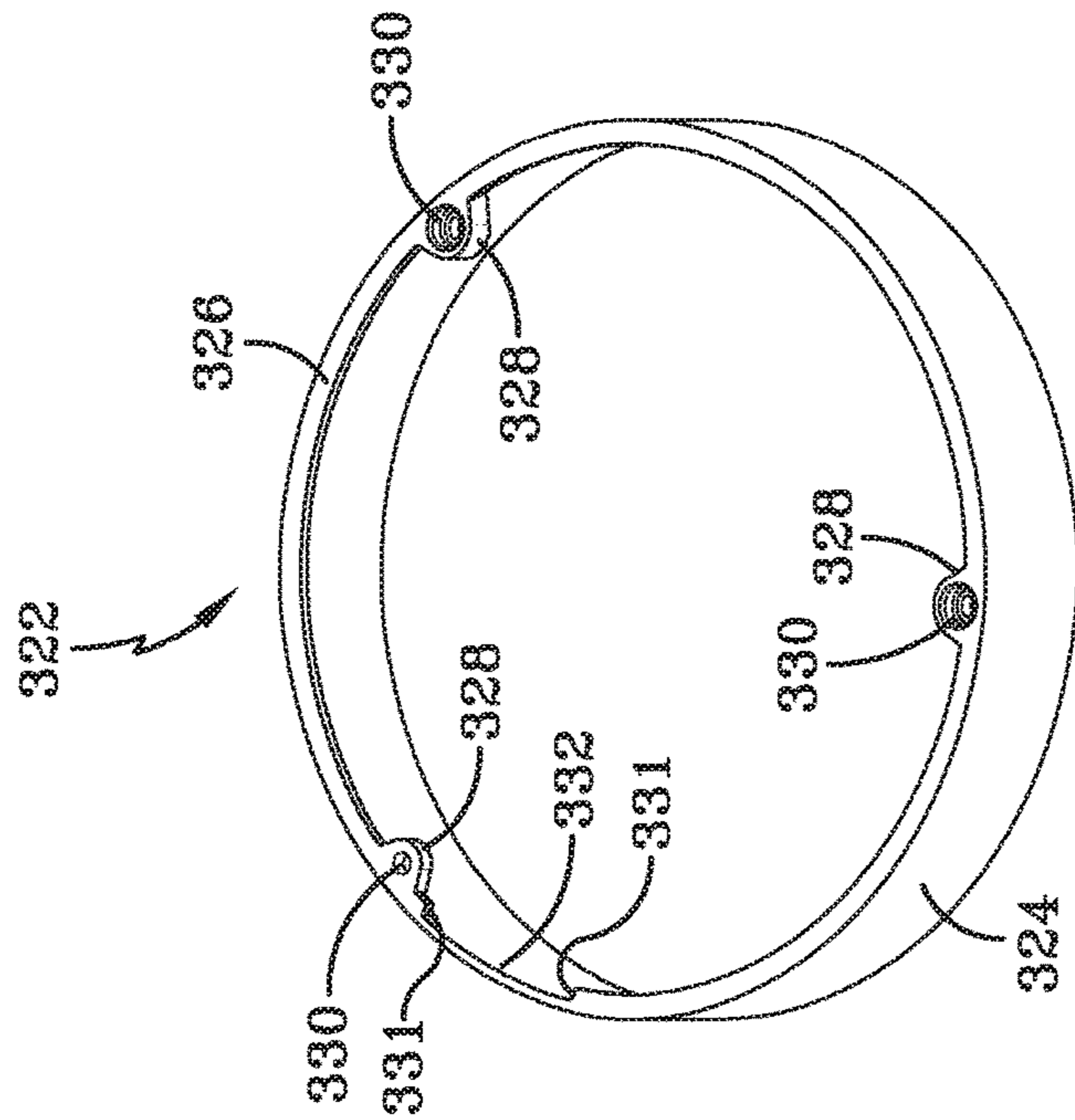
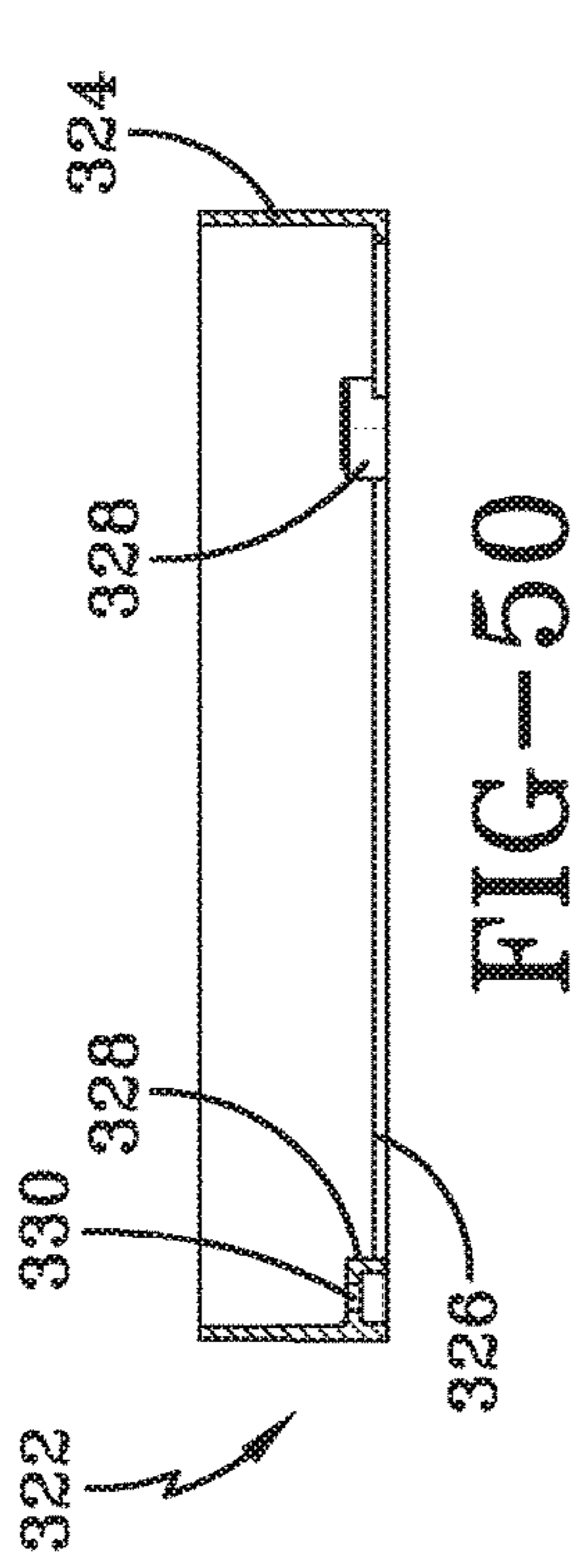

FIG-47



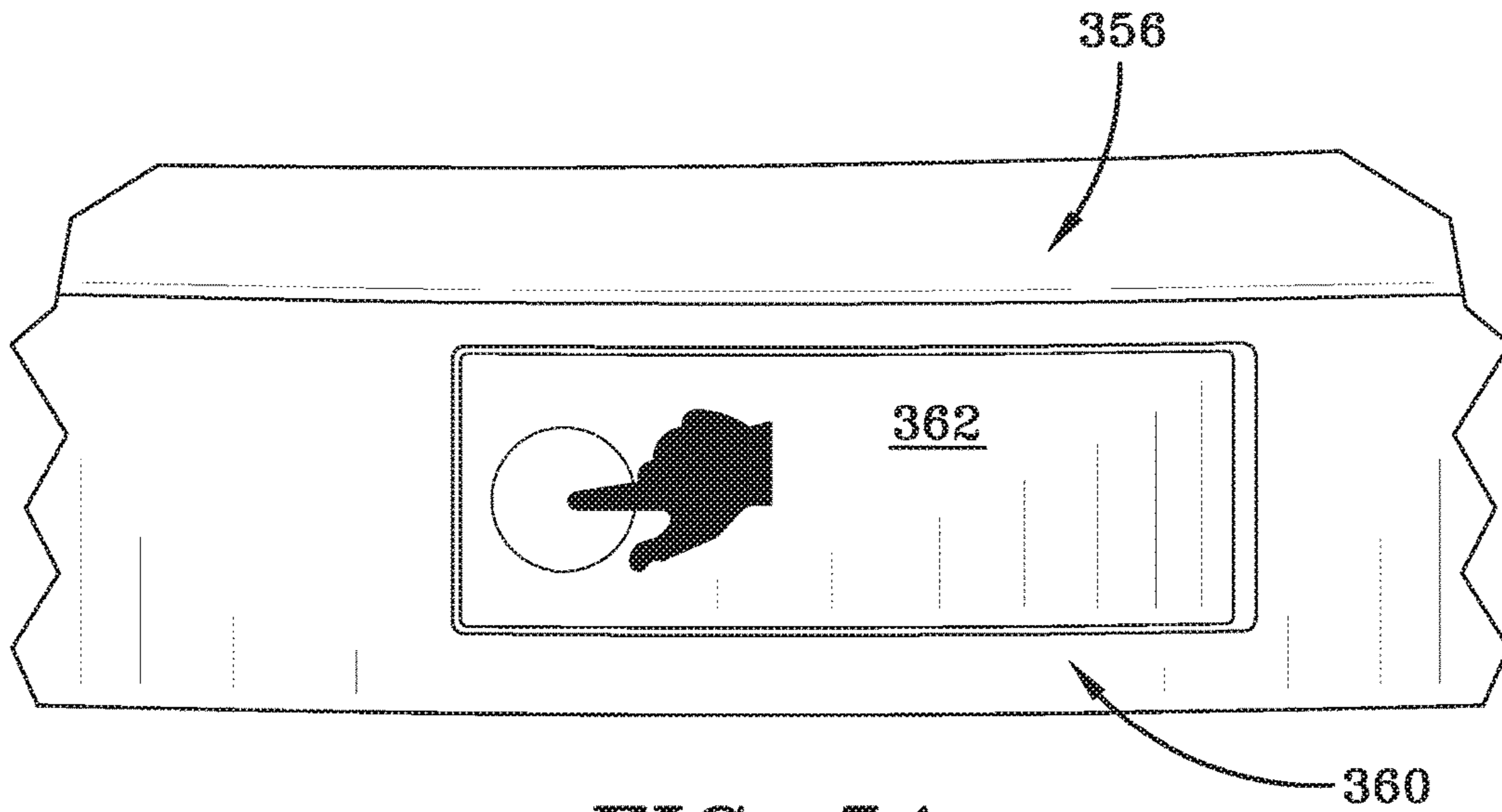

FIG-51

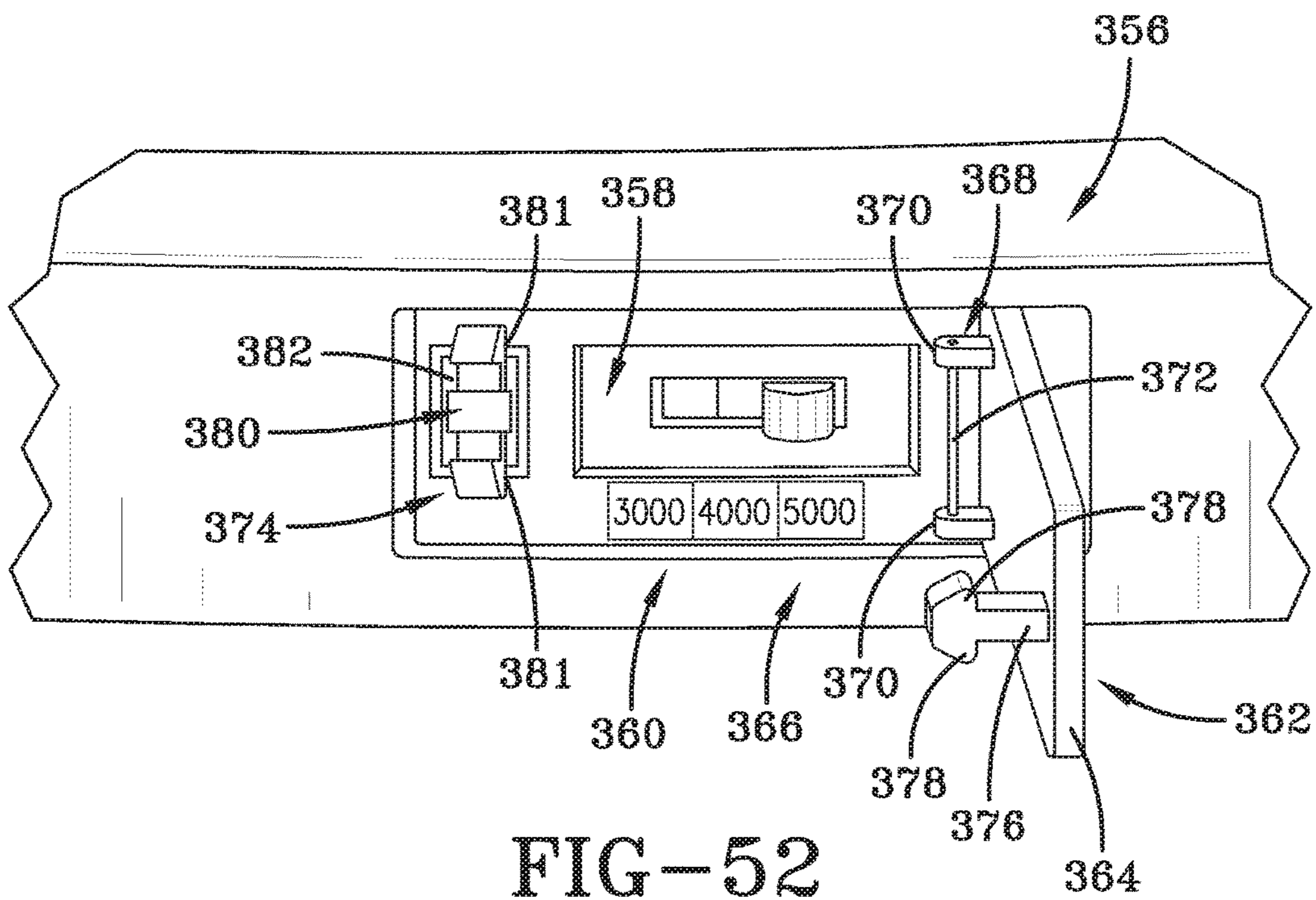

FIG-52

**MANUALLY CONTROLLABLE LED
CORRELATED COLOR TEMPERATURE
LIGHT FIXTURE**

Matter enclosed in heavy brackets [] appears in the original patent but forms no part of this reissue specification; matter printed in italics indicates the additions made by reissue; a claim printed with strikethrough indicates that the claim was canceled, disclaimed, or held invalid by a prior post-patent action or proceeding.

CROSS-REFERENCE TO RELATED
APPLICATION

This application is a reissue of U.S. Pat. No. 10,091,855 (the '855 Patent) filed on Jan. 15, 2018, issued from U.S. patent application Ser. No. 15/871,433, which claims priority of U.S. Provisional Application No. 62/455,824 filed on Jan. 13, 2017 of which is incorporated herein by reference in its entirety.

This application claims priority of U.S. Provisional Application No. 62/445,824 filed on Jan. 13, 2017 of which is incorporated herein by reference in its entirety.

BACKGROUND OF THE INVENTION

Field of the Invention

This invention relates to LED lighting units, and in particular to LED light fixtures having manually controllable correlated color temperature (CCT) to obtain different correlated color temperatures.

Description of the Prior Art

LED lamps incorporate light emitting diodes (LEDs) which are semiconductor light sources having a semiconductor diode and photo luminescent material. An LED is a diode which permits the flow of electrical current in only one direction. In an LED, there are two conductive materials in contact with each other—a positive or p-material, and a negative or n-material. When a p-material is in contact with an n-material, a single p-n conductor is formed. The atoms in the n-type material have extra electrons while the p-type material has electron deficiencies or holes. When the p-type and n-type material are close to each other, the extra electrons of the n-type material transmit its extra electrons to holes in the p-type material. This results in the release of photons. However, only those diodes which release photons that are in the visible part of the light spectrum emit light and those diodes are LEDs.

LED lights have become very popular because they last longer and use far less electricity than incandescent bulbs. LED lights, particularly of the type disclosed herein, generate white light. White light is a combination of multiple wavelengths of light. One way of characterizing white light is by the use of color temperature. This means the color of light within the white light. CCT is a specification of color appearance of the light emitted by a lamp. It relates to the color from a reference source which is heated to a particular temperature, measured in degrees Kelvin (K). The CCT rating of a lamp in general refers to the warmth or coolness of the lamp. CCT is basically a gauge of how blue or yellow the color of light emitted from a source of illumination appears. Lamps with a CCT rating below 3200K are considered warm sources, whereas those above 4000K are

considered cool sources. The color temperature of a light source is the temperature of an ideal black-body radiator that radiates light of comparable color to that of the light source. As mentioned above, color temperatures over 4000K are generally called cool colors (bluish white), while lower temperatures (2700K-3000K) are referred to as warm colors (yellowish white through red).

LEDs are usually either indicator-type LEDs if they have low intensity, and illuminator-type LEDs if they are high power devices that provide illumination—as is the case in the present invention. LEDs are classified in part according to their CCT. A color difference has a threshold at which it becomes observable based on an ellipse (called the Mac-Adam ellipse) over the color space so that the color at its center changes by a certain amount at any particular amount along its edge. The scale of this ellipse is referred to as the standard deviation of color matching or SDCM. A color difference of 2 SDCM is not readily visible. Color differences are intended to be small by light fixture manufacturers. LEDs are “binned” to classify the LEDs so that the CCTs of LED in a bin appear to be the same. The present invention uses LEDs of different CCTs; hence binning is significant.

Neutral white light is generally 4000K-4500K, direct sun is generally around 4800K, day-white is 5000K-6000K, cool white is generally 7000K-7500K and blue sky is considered to be 10000K. LED downlights have become more and more popular. However, while these lights can be mass produced and easily affordable, it has been desirable to incorporate easily operable, manual systems for controlling the CCT that is efficient, effective and inexpensive.

It has also been found very useful to incorporate such lights in recessed cans which are installed in many residences, commercial buildings, hospitals, educational institutions and the like.

For LED lamp fixtures, it has been found desirable to use LEDs with various CCTs because of different tones of light desired.

For example, there have been various recommendations for CCTs for different environments. With respect to restaurants, it is been recommended that high-end restaurants use warmer color temperatures from 1800K-2700K. Court-serve restaurants, warm, but not as warm as high-end restaurants, the recommendation is 2700K-3500K. For hotel lobbies, a recommendation in the 1800K-3000K range. For guest rooms in hotels, one recommendation is in the 2700K-3000K range to create a warm and inviting atmosphere. However, in offices, a recommendation is in the 3000K-4000K range to provide a neutral to cool color temperature. With respect to healthcare, such as in hospitals, cooler color temperatures have been recommended in the 3500K-5000K range. Of course, if a particular space is used for different purposes, it would be very advantageous to be able to change the CCT. Moreover, different individuals or groups of individuals may have their own personal preference for a particular range of CCTs. Thus, LED light fixtures with easily variable CCTs would be most advantageous.

BRIEF SUMMARY OF THE INVENTION

It is an object of the present invention to provide an LED light fixture having a manually controllable CCT feature.

Another object is the provision of LED light fixtures including various manually operable CCT switches including toggle switches, rotary switches, pull chain switches, DIP switches, push button switches and slide switches.

3

It is a further object of the present invention to provide improved CCT LED light fixture of modest cost with easily accessibly manually variable correlated color temperatures.

It is also an additional object of the present invention to provide a manually controllable LED CCT light fixture having sets of LEDs wherein each set of LEDs has a different CCT, and the sets are arranged on a printed circuit board to yield a particular arrangement of luminosity, such as uniformly across the printed circuit board.

Another object of the present invention is to provide a manually controllable CCT for a recessed LED downlight.

It is a further object of the present invention to provide an LED downlight which can easily be installed in a recessed can, and which further has an easily accessible manual switch for controlling the correlated color temperature of the LED lamp.

A still further object of the present invention is to provide an economical, recessed LED light fixture incorporating an effective and efficient manually operable CCT control switch.

It is yet another object of the present invention to provide a recessed LED downlight which is color tuneable, and which can be easily installed in a recessed can.

It is also an object of the present invention to provide an LED lighting module which is color tuneable and incorporates a manually variable CCT switch feature.

An additional object of the present invention is the provision of an LED fan light kit that is color tuneable and includes a manually operable CCT select switch.

It is yet a further object of the present invention to provide a flush-mounted, color tuneable LED light having a manually operated CCT select switch.

It is also an object of the present invention to provide an electric fan assembly including a manually controllable CCT light kit.

Another object of the present invention is to provide a manually actuatable CCT select switch in a light fixture which is not readily visible when the light fixture is in an operative position, but is easily rendered in an operable position for finger actuation.

Another related object of the invention is the provision of a compartment in a light fixture for holding a manually operable CCT select switch, which compartment is not observable when the CCT select switch is not available for use.

A further object of the invention is to provide a concealment for hiding or making less obvious the manually actuatable CCT switch assembly with respect to light fixtures incorporating the manually controllable CCT light fixture.

Another related object is the provision of a compartment for a CCT select switch which includes a closure such as a door for selectively holding the CCT select switch in storage, which door can be opened for access to the switch.

It is a general object of the present invention to provide an LED light fixture including a manually controllable, easily accessible CCT select switch that is an easily operated, inexpensive, efficient and effective.

Other objects are apparent from the description to follow and from the appended claims.

BRIEF DESCRIPTION OF THE DRAWINGS

FIG. 1 is a perspective view of a recessed LED downlight with selectable color temperature with a manually controllable CCT select switch according to a preferred embodiment of the invention for insertion into a recessed can.

4

FIG. 2 is a perspective view of another preferred embodiment of the invention which is another form of the recessed LED downlight having selectable color temperature and provided with a manually controllable color temperature for insertion in a recessed can.

FIG. 3 is an exploded view of a recessed LED downlight as shown in FIG. 1.

FIG. 4 is a side view of the recessed LED downlight shown in FIGS. 1 and 3, and

FIG. 5 is a front view thereof.

FIG. 6 is an exploded view of the recessed LED downlight shown in FIG. 2.

FIG. 7 is a side view of the recessed LED downlight shown in FIGS. 2 and 6.

FIG. 8 is an enlarged front view of a manually operated switch for selecting a CCT for an LED light fixture with an indicator showing three possible settings for the switch.

FIG. 9 is a side view of a CCT downlight switch for the recessed LED downlight shown in FIG. 1, and FIGS. 10-12 are perspective, rear and a cross-sectional view taken in the direction 12-12 in FIG. 11.

FIG. 13 is a circuit diagram of a circuit that could be incorporated in the recessed LED downlights shown in FIGS. 1 and 2.

FIGS. 14A-14B are respectively a schematic diagram and a symbolic symbol of a single pole single throw toggle switch that could be used in the manually controllable LED/CCT light fixture according to the present invention.

FIGS. 15A and 15B are respectively a schematic drawing and a symbolic symbol of a single pole double throw toggle switch as another type of switch that could be used in a light fixture according to an embodiment of the present invention.

FIGS. 16A-16B are respectively a schematic drawing and a symbolic symbol of a double pole double throw toggle switch as still another switch for use in a light fixture incorporating the present inventive concepts of another embodiment of the invention.

FIG. 17 is a symbolic symbol for one pole of a three pole way rotary switch as yet another switch for use in an embodiment of the present invention.

FIGS. 18A and 18B are two symbolic symbols of push button switches which also can be used as CCT manual switch in an embodiment of the present invention.

FIGS. 19A and 19B are respectively electronic symbols of push-to-make and push-to-break switch for employment in other embodiments of the invention.

FIG. 20 is a side view of a ceiling fan LED light kit incorporating a manually variable CCT according to an embodiment of the invention.

FIG. 21 is a fan connect assembly incorporated in the fan LED light kit shown in FIG. 20.

FIG. 22 is an exploded view of the ceiling fan LED light kit shown in FIG. 20.

FIG. 23 is a circuit diagram for the ceiling fan LED light kit that could be used in the LED light kit shown in FIGS. 20 and 22.

FIG. 24 is an enlarged front view of slide switch assembly with an indicator showing three possible settings of the slide switch for use in the present embodiments, and particularly on those shown in FIGS. 20 and 22.

FIG. 25 is a perspective view of an LED color changing ceiling light incorporating the present invention, and

FIG. 26-28 are a second perspective view, a side view and a front plan view of the ceiling light shown in FIG. 25.

5

FIGS. 29-31 are perspective, side and plan views of the so interior portion of the ceiling light shown in FIGS. 25-28 when the ceiling light is in a position to be attached to a ceiling.

FIGS. 32-34 are perspective, side and front plan views of another version of the LED color changing ceiling light fixture according to the present invention.

FIGS. 35-37 are perspective, side and front plan views of the interior of the ceiling light fixture shown in FIGS. 32-34.

FIG. 38A-38C are circuit diagrams of alternate circuitry for each of the ceiling light fixtures shown in FIGS. 25-37 and 39-50.

FIG. 38D is a circuit diagram for a related circuit that could be used in such ceiling light fixtures.

FIGS. 39-40 are a perspective and a side view of a flush mount light fixture according to another embodiment of the invention.

FIG. 41 is an exploded view of the embodiment of the invention shown in FIGS. 39 and 40.

FIGS. 42-46 are, respectively, a top perspective view, a bottom perspective view, a bottom plan view, a cross sectional side view taken along the lines 45-45 in FIG. 45 and a side view, of the bottom cover incorporated in the light fixture shown in FIGS. 39-41.

FIG. 47 is a plan view of the printed circuit board used in the embodiment of FIGS. 39-46.

FIGS. 48-50 are, respectively, a perspective view, a bottom view and a cross-sectional view taken along the lines 50-50 in FIG. 49, of a loop incorporated in the flush mount light fixture shown in FIGS. 39-41.

FIG. 51 is a front view of a compartment for a CCT select switch showing a door for providing access to the switch.

FIG. 52 is a front view of the compartment shown in FIG. 54 with the door in an open position.

DETAILED DESCRIPTION OF THE PREFERRED EMBODIMENTS

As explained earlier, changing CCT is very desirable, and with the growing popularity of LED lamps and light fixtures incorporating such lamps, it is most desirable to provide easily variable CCTs for LED lights and light fixtures. The present invention provides manually controllable or operable LED CCTs for many commonly available LED light fixtures, including downlights installable in a downlight receptacle referred to as a frame or "can," conventional LED lamps, appliances such as LED fan light kits, ceiling mountable LED light fixtures such as flush mount light fixtures and the like. The invention involves a manually operable switch incorporated in an electric circuit for powering an LED light that has a controllable CCT, the circuit including electronic components which are manually selectively actuatable for activating one of a series of components of different light temperature. The term "manually controllable" includes controlled by a person's fingers, i.e. digitally. By means of mere manual movements of a switch, especially digital movements, an accessible switching element can be adjusted to select a specific CCT. Although any number of correlated color temperatures could be employed, three light temperatures has often been found to be appropriate—particularly for household, industrial and institutional uses.

Referring first to FIGS. 1 and 3, these figures show respectively an assembled and an exploded view of a 5 inch/6 inch recessed LED downlight 100 with manually variable CCTs. Referring specifically to FIG. 3, downlight 100 incorporates a light module 1, and light module 1 includes a housing assembly comprising a box or electronics

6

container 3 for holding electrical components which in turn holds a driver 5; light module 1 further comprises a housing 7 which includes a truncated heat sink 9 and a shade 11, and a manually controllable CCT switching device in the form of an easily accessible manually operable CCT switching assembly 13. Driver box 3 is attached to heat sink 9. Shade 11 is located on the inside of heat sink 9. A printed circuit board 15 is located proximal a closed end 17 of heat sink 9. A reflector 19 is in effect a liner for shade 11, and is attached to closed end 17 of heat sink 9 with screws 21 extending through tabs 23 having holes therein, passing through peripheral notches 25 in printed circuit board 15. A diffuser 27 is attached to housing 7 by means of radially extending tabs 29 extending into a recess between shade 11 and housing 7. A mounting assembly 31 is composed of a pair of V-clip supporting brackets 33, to which are attached V-clips or torsion springs 35, and the foregoing component parts of mounting assembly 31 are connected together by a set of screws 37 extending through slots in each of V-clip supporting brackets 33 into screw holes in mounting assembly supporting brackets 39.

A more detailed discussion of the components of light module 1 will now be described. Referring to FIGS. 3, 4 and 5, the respective exploded, side and front views of the 5 inch/6 inch recessed LED downlight 1 are shown. Heat sink 9 is provided for absorbing heat generated by the LED light sources incorporated in recessed LED downlight 1 on printed circuit board 15, and shade 11 is a liner for heat sink 11. Bracket 33 is provided for holding V-clips 35 in place. Diffuser 27 transmits light emitted by the LEDs mounted on printed circuit board 15 of module 1. Reflector 19 located inside of heat sink 9 and lies against the inner surface of housing 7 on shade 11. A gasket 43 sits on a plastic rim 45 of housing 7. Housing 7 includes a truncated plastic portion 47 out from which extend a series of parallel annular rings 49 (FIG. 5) having a common longitudinal axis. Housing 7 overall has the shape of a truncated cone.

Manually operable CCT switch assembly 13 includes a slide switch 51 shown in FIGS. 8-12. Slide switch 51 comprises a digitally operated switch actuating member such as a slide 52 constructed as a hollow stem that is digitally slideable to result in the actuating of a switch member S1 shown in the circuit diagram of FIG. 13 to change the CCT depending to which contact 1, 3 or 4 of CCT switch assembly 13 operatively is connected. Slide switch 51 of CCT switch assembly 13 further comprises a curved plate 53 which is slideable along a curved wall 55 of CCT switch assembly 13 (FIG. 3). Curved wall 55 has the same curvature as does curved plate 53. Driver box 3 has an opening 57 (also shown also in FIG. 3) through which slide 52 extends so that a user with the user's fingers can move slide 52 along opening 57 to select a specific correlated color temperature. Slide switch 51 is shown in detailed view of FIG. 8. Opening 57 in driver box 3 can advantageously have three settings for color temperatures 3000K, 4000K and 5000K shown on a setting scale 60.

Manually controllable CCT switching assembly 13 is a preferably manually controllable by means of slide switch 51, but other types of CCT switching devices fall within the scope of the invention. For example, toggle switches are possible. Referring to FIGS. 14A and 14B, a single pole single throw toggle switch (SPTS) 61 is shown schematically. SPTS switch 61 has a manually movable actuator 63 movable between ON and OFF positions indicated by arrow 65. SPTS switch 61 could be modified for any number of correlated color temperatures to be selected. Contact is made by switching actuator 63 with an ON connect 67 to connect

an electric power source to the lighting circuit, and for switching to an OFF contact **69**, to disconnect the power source from the lighting circuit. SPTS **61** could be connected to replace slide switch **51**. Another switch for replacing slide switch **51** is a single pole double throw (SPDT) switch **71** as depicted in FIGS. **15A** and **15B**. SPDT switch **71** includes a manually movable actuator **73** movable between an up position to connect a terminal **79** which is connected to one power source to a common terminal **77** and disconnected from terminal **75**, and a down position which connects another power sources at terminal **75** to common terminal **77** and disconnects the power source from electrical connector **79** from common terminal **77**. SPDT switch **71** could also be modified for different CCTs to be selected. Another toggle switch that could be used in place of slide switch **51** is a double pole double throw (DPDT) switch **81** which operates like two separate SPDT switches connected to the same circuit, and shown in FIG. **16A** and with a schematic symbol shown in FIG. **16B**. DPDT switch **81** has a manually movable actuator **83** having a pair of connected switch arms **85** and **87**. DBDT switch **81** could be altered for any number of CCTs to be selected. When actuator **83** is in the UP position, switch arm **85** is not engaging terminal A, and arm **85** is disconnected from terminal A and connected to terminal B to connect terminal B and common terminal C; arm **87** is simultaneously not engaging terminal D but does connect common terminal E to terminal F. When actuator **83** is in the DOWN position, switch arm **85** connects common terminal C and terminal A and is disconnected from terminal B; and switch arm **87** simultaneously connects common terminal E to terminal D and is disconnected from terminal D.

Another appropriate switch for being used in place of slide switch **51** is a rotary switch. FIG. **17** shows a circuit for one pole of a three pole four way rotary switch **91**. Rotary switch **91** has a spindle **89** which is movable between four poles A, B, C and D. These poles would be modified to correspond to terminals corresponding in number to terminals **1**, **2** and **4** in FIG. **13**. Rotary switches come in a variety of pin arrangements. The most common are the following: 1 pole 12 way, 2 pole 6 way, 3 pole 4 way and 4 pole 3 way. In a 3 pole 4 way switch, for example, a pole A is connected to ways **1**, **2**, **3** and **4**; pole B to ways **5**, **6**, **7** and **8**; and a pole is connected to poles **9**, **10**, **11** and **12**. Turning spindle **86** connects each pole to one of its ways in turn, with each pole/way set switching.

Another manually operable type of switch that can be used as an alternative to slide switch **51** is a DIP switch which is known in the art. A DIP switch is a manually operable switch packaged with others in a group in a standard dual in-line package (DIP). DIP switches are designed for use on printed circuit boards with other electronic components. DIP switches are of various types including the rotary type, the slide type (two common slide switches in a DIP package are recessed slide switch and a non-recessed or extended slide switches) and a rocker type. Rotary DIP switches have multiple electrical contacts, and a switch is rotated to align it with a number printed on the package. These could be large that could be changed by thumb wheels, or very small so that a screwdriver must be used. The slide and rocker types having arrays of single pole, single throw (SPST) contacts that can be either on or off. This permits each switch to select a one-bit binary value. The values of all switches in the package to be interpreted as one number. A double-pole double throw DIP switch are available as SPST switches.

The DIP switch package also has socket pins to provide an electrical path from the switch contacts to the circuit

board. It is common to convert the circuits to high and low signals rather than using the contacts directly. When used to convert the circuits to high and low signals, the circuit board needs interface circuitry for the DIP switch, which consist of a series of pull-up or pull-down resistors, a buffer, decade logic and other components. In most cases, the device's firmware reads the DIP switch when the device is powered on. DIP switches are small, inexpensive and use low current and low voltage.

A push switch is another alternative to slide switch **51**. Two types of push button switches are shown in FIGS. **18A** and **18B** by symbolic symbols **93** and **94**. FIGS. **19A** and **19B** show, respectively, a push-to-make switch **95**, shown as a symbolic symbol in FIG. **19A**, and a push-to-break switch **96** shown as a symbolic symbol in FIG. **19B**. Such push button switches are non-latching switches to cause a temporary change in a circuit when activated, with an automatic return mechanism such as a spring used to return the switch to its stable state. Push-to-make switch **95** includes an actuator **97** for engaging electrical contacts **99**. Similarly, push-to-break switch **96** includes an actuator **101** which is biased to close electrical contacts **103** and must be pressed to open the circuit. Push switches can also be used to replace slide switch **51** which function as a push-to-make or a push-to-break switch, depending on the wiring. Push-to-make switches **95** and push-to-break switches **96** could be modified to actuate different numbers of CCTs.

Referring to FIG. **2**, and FIGS. **6** and **7**, a 4 inch recessed LED downlight **200** with selectable correlated color temperature is shown having an LED light module **60**. Module **60** includes a heat sink **62**, a shade **64**, three clips **66**, a diffuser **68**, a driver box **70** holding a driver **72**, and a rim **74**. Diffuser **68** is attached to a reflector **76**. A printed circuit board **78** is connected to heat sink **62** by screws **80** extending through appropriate screw receiving holes. Clips **66** are preferably made of sheet metal and are attached to heat sink **62** by screws **82** extending through screw receiving holes in heat sink **62**. Clips **66** have bent-over flanges **84** for engaging the wall of a downlight receiving well in a ceiling or the like. An electrical receptacle assembly **86** receives an electrical plug within a downlight receiving well to provide electrical power to driver **72**. A slide switch **32** corresponds both in structure and as being part of a manually operable CCT switch assembly corresponding to CCT switch assembly **13** described in detail above with respect to downlight **100**, and reference is made thereto, as well as to other switch variations in different types of switches for varying the CCTs.

Each of recessed LED downlights **10** and **200** are installed in a receptacle R, and the cooperation of respective downlights **100** and **200** and receptacles R form a concealment for concealing slide switches **51** and **32**, to render slide switches **51** and **32** non-observable and inaccessible for operation. Once downlights **100** or **200** are partially or completely removed from the receptacle, the respective slide switches are accessible for operation.

A ceiling fan LED light kit with a manually controllable CCT switch according to the invention will now be described. Referring first to FIGS. **20** and **22**, a ceiling fan assembly **300** includes a ceiling fan LED light kit **102** incorporating a manually controllable CCT switch **103** is shown. Ceiling fan LED light kit **102** includes a diffuser in the form of a light transmitting cover **104** attached to a cover support in the form of a base plate assembly **106**. Between cover **104** and base plate **106** are disposed a printed circuit board adapter structure which advantageously includes a first printed circuit board adapter **108**, a second printed

board adapter structure **120** and three printed circuit board adapters **124**. Ceiling fan LED kit **102** comprises an electrical components container box in the form of a driver box **110** attached to base plate assembly **106** by screws **111** extending through tabs **112**, a driver **114** shielded by an insulator **116** and held in place in driver box **110** by a driver box cover **118**. Also included in the LED light kit are a second printed circuit board adapter **120** noted above, a switch holder **122**, screws **128** holding manually adjustable CCT switch **103** in place, and a pull chain **130** extending from a pull chain holder **132**. Extending upwardly from base plate **106** are a screw base **134** and a socket **136** into which an LED light source with an Edison adapter can be installed. FIG. **21** shows a fan connect assembly **138** on which can be attached to an appropriate cap. Manually adjustable switch **103** is a slide switch corresponding in structure and with its electrical circuitry to that described above with respect to manually operable CCT switch assembly **13**, and reference is made thereto for a detailed description as used in ceiling fan assembly light fan kit **102**. Manually adjustable switch **103** is used to change the correlated color temperature of the light by an easy manual operation. The electronic circuitry for manually controllable fan light **120** is shown in FIG. **23**.

Cover **104** has a diffuser **144** configured as a spherical segment for diffusing illumination from the LED light source incorporated in assembly light fan kit **102**. It incorporates bayonet threading **145** for enabling it to be twisted in place on corresponding threading **148** on base plate assembly **106**. Diffuser **144** is easily removable to provide manual access to CCT switch for easy manual operations. The fan would be operated separately from the LED light.

Ceiling fan LED light kit **102** could use a slide switch corresponding to that shown and described in FIGS. **8-12**. The body of the LED light kit is a concealment to the CCT switch. Any of the other switches described hereinabove could be used as well, adapted to the purpose required for the ceiling fan LED light kit.

A slide switch assembly **146** shown in FIG. **24** is an appropriate manually controllable CCT switch ceiling fan light kit **102**. It includes a housing **147** which could be made from an appropriate plastic, for housing the electronic circuitry and a slide **148** which is used to manually change the CCT. A slot **149** is used to contain and enable the sliding of slide **148** between various CCTs for which CCT switch assembly is adjustable. Slide **148** is slidable between three CCTs, namely 3000K, 4000K and 5000K. Of course any number of CCTs are possible, and in any values of CCT. It has been found that 3000K, 4000K and 5000K are particularly advantageous, 3000K referring to yellow light, 4000K referring to bright white light and 5000K referring to daylight. An indicator **150** designates the proper stopping point for slide **148**. A pair of stops **151** are provided at opposite ends of slot **149** to indicate to the user the endpoints to which slide **148** can be moved.

One version of an LED color changing ceiling light fixture is shown in FIGS. **25-28**, whose interior portion is shown in FIGS. **29-31**. Considering the exterior portion first, a color changing ceiling light fixture **152** has a generally square cross-section when viewed at an angle perpendicular to its longitudinal central axis when fixture **152** is hung from a ceiling. It only has a "general" square cross-section with rounded corners. LED color changing ceiling light fixture **152** incorporates a translucent diffuser **154** through which light is transmitted, and an exterior frame **156** for holding the interior of fixture **152** as described below, a base **158** disposed on top of fixture **152** when fixture **152** is proximal a ceiling when fixture **152** is attached to the ceiling. Sets of

holding brackets **160** which are removable from frame **156** enable the removal of diffuser **154** from frame **156** and base **158** to provide access to slide switch assembly **146** as discussed below. Each bracket **160** includes a central rod **162** flanked by two rods **164**. Each bracket is composed of three rods having rectangular cross sections with parallel end portions; each rod including a central portion which extend vertically along frame **156** when fixture **152** is attached to a ceiling. The portions of each bracket **160** are generally horizontal with the lower portions being engageable with diffuser **154** to hold diffuser **154** in place to prevent the discharge of diffuser **154** from frame **156**. The upper horizontal portions of each bracket **160** act like a fingers to retain the respective brackets in place when diffuser **154** is being held against frame **156**. Rods **162** and **164** of each bracket **160** are integral so that the entire respective brackets **160** must be removed in order to enable the discharge of diffuser **154** from fixture **152**.

The interior of LED color changing ceiling light fixture **152** is shown in FIGS. **29-31**. The interior portion is designated by numeral **170**. Base **158** also has a generally square cross-section and is contoured to receive frame **156** along its border. A printed circuit board **172** is attached to base **158** by means of a set of screws **174**. Mounted on printed circuit board **172** is a series of LEDs **176**. LEDs **176** are arranged according to respective CCTs, the number of types of LEDs is determined according to the number of CCTs to which LED color changing ceiling light fixture can be set. Although different LEDs **176** with respective CCTs are not indicated in FIGS. **29** and **31**, they preferably would be distributed on printed circuit board **172** in a uniform manner so that the illumination for any selected CCT would be constant and uniform when fixture **152** is illuminated for each of the color temperatures. Sets of keyholes **178** and **179** are provided in base **158** for receiving mounting screws to attach plate **158** to an electric outlet box.

A housing **180** located in interior portion **170** of base **158** holds the electronics for operating the LEDs which follow the circuitry shown in FIGS. **38A-38C** discussed below. Also mounted on base **158** is a manually adjustable switch, which is shown as manually adjustable slide switch assembly **146** shown in FIG. **24**. Switch assembly **146** includes indicator **148**, which is not shown in FIGS. **29** and **31** due to space limitations. As explained above, slide **147** can be manually adjusted to select a desired CCT. Also not shown are the electrical conductors extending from the circuitry inside of housing **180** to printed circuit board **172**, since these were omitted for the sake of clarity of FIGS. **29** and **31**.

In order to remove brackets **160** from obstructing removal of diffuser **154**, a pair of releasable latches **182** was partly shown in FIGS. **29-31**. Latches **182** have latch arms **183** mounted on posts **185** to enable the rotation of arms **183** to selectively retain or release diffuser **154**. Latches **182** enable the removal of diffuser **154** from fixture **152** to make possible the desired easy setting of slide switch assembly **146**, and to enable the replacement of diffuser **154** on fixture **152** once the proper setting of slide **147** has been achieved. Diffuser **154** is a concealment to render slide switch assembly **146** unobservable and inaccessible when it is connected to base **158**, and renders slide switch assembly **146** observable and accessible once it is removed from base **158**.

Slide switch assembly **146** is attached to base **158** by means of a pair of screws **184** which extend through tabs extending from a housing **186** of switch assembly **145** as shown in FIGS. **29** and **31**. Housing **180** also has a pair of tabs for which another set of screws **188** is used to attach housing **180** to base **158**. Although not shown, a set of

electrical leads are disposed on a side **190** opposite to the side of base **158** shown in FIGS. **29** and **31**. These leads would be operatively connected to the appropriate circuitry in the ceiling to which fixture **152** is to be electrically connected.

Another version of an LED color changing ceiling light fixture is shown in FIGS. **32-37** and identified by the numeral **192**. Electrical structure and operation of fixture **192** is nearly identical to that of LED color changing ceiling light fixture **152**, and reference for a full description of fixture **192** is made to the description of fixture **152**. Thus, LED color changing ceiling light fixture **192** includes a diffuser **194**, which is basically round in a plan view as shown in FIG. **34**. Diffuser **194** is mounted against a frame **196** and held in place by a set of brackets **198** whose structure and function is virtually the same as that of brackets **160** in FIGS. **25-28**, to which reference is made for a more detailed description of brackets **198**. Fixture **192** includes a base **200** as shown in FIG. **33**, which is proximal a ceiling when fixture **192** is mounted to the ceiling. Base **200** extends above frame **196** when fixture **192** is mounted to the ceiling. Base **200** has a rim **202** which is shown in FIG. **33**. Diffuser **194** is a concealment to the slide switch assembly when it is attached to base **200** as discussed with respect to ceiling light fixture **152**.

FIGS. **35-37** show the interior of fixture **192**. Mounted on base **200** is a printed circuit board **203** which can be identical to circuit board **172** shown in FIGS. **29** and **31**. Printed circuit board **203** is mounted against base **200** by means of a set of screws **204**. There is the same variation in a set of different CCTs of sets of LEDs **207** as existed in the set of LEDs **176** shown in FIGS. **29** and **31**. Sets of LEDs **207** are attached to printed circuit in the same manner as LEDs **176** were attached to printed circuit board **172** in the embodiment shown in FIGS. **26-31**. Circuit board **203** is essentially U-shaped, providing room for a housing **208** which is held in place by screws **212** extending through tabs **210** extending from the corners of housing **208** and into an appropriate hole in base **200**. Manually adjustable switch assembly **146** is also attached to base **200** by means of screws **214** extending through tabs on the corners of switch assembly **146** through holes in base **200**. Rim **202** extends around base **200** as mentioned earlier, and is raised upwardly from base **200** when fixture **192** is mounted on a ceiling, and extends far enough to cover printed circuit board **206**.

Extending through the base **200** of fixture **192** are sets of keyholes **213** and **215**. These key holes are provided to enable the connection of LED color changing ceiling light fixture **192** to an electric outlet box by means of mounting screws.

Circuit diagrams for the switching circuitry used for operating the manually controllable LED CCT light fixtures shown in FIGS. **25-37** (color changing ceiling lights) and described herein, and those shown in FIGS. **39-50** (color changing flush mount) and described herein below, are shown in FIGS. **38A-38C**. Referring first to FIG. **38A**, a switch **219A** controls current running through resistors **R1-R6** and the two LEDs **C1** and **W1** as shown. When switch **219** is in the **1** and **1'** position, current flows through LED **C1**. When switch **219A** is in the **2** and **2'** position, part of the current flows through **R1** and **C1**, and part of the current flows through **R4** and **W1**. When switch **219A** is in the **3** and **3'** position, part of the current flows through **R2** to **C1**, and part of the current flows through **R5** and **W1**. When switch **219A** is in the **4** and **4'** position, part of the current flows through **R3** and **C1**, and part of the current flows

through **R6** and **W1**. Finally, when switch **219A** is in the **5** and **5'** position, with current flows to LED **W1**.

Variations are possible with the switching circuits shown in FIGS. **38B** and **38C**. Referring to FIG. **38B**, when switch **219B** is in **1-1'** position, current flows to LED **C1**. When switch **219B** is in the **2-2'** position, current flows through **R1** and LED **C1**, and through **R2** and LED **W1**. Finally, when switch **219B** is in the **3-3'** position, current only flows to LED **W1**. Lastly, referring to FIG. **38C**, when switch **219** is in the **1-1'** position, current flows to LED **C1**. When switch **219C** is in the **2-2'** position, current flows through **R1** and LED **C1**. When switch **219C** is in the **3-3'** position, current flows through **R2** and LED **C1**, and through **R5** and LED **W1**. When switch **219C** is in the **4-4'** position, current flows to LED **W1**. FIG. **38D** is another version of a related switching circuit.

Referring first to FIGS. **39-41**, an LED light fixture **220** is shown. Light fixture **220** is a flush mount light fixture. Light fixture **220** includes a diffuser **222** which is preferably made of a translucent plastic, and a bottom cover **224**. Bottom cover **224** has a peripheral, forwardly-extending outer wall **226** that is frusto-conical in configuration, flaring outwardly to an outwardly-flared, frusto-conical rim **228** having a greater amount of chamfer than does outer wall **226**. Housing base **224** has a forward housing base portion **230**. Forward refers to being proximal a floor when LED light fixture **220** is mounted to a ceiling with diffuser **222** facing downwards, and rearward likewise means proximal the ceiling. LED light fixture **220** is defined as being "integral" because all of the components are self-contained; all one needs to do is simply screw the integral LED light fixture **220** into an incandescent light bulb socket.

FIG. **41** is an exploded view of LED light fixture **220** showing diffuser **222** and housing base **224** described above. A socket base **234** is provided in the rear portion of lamp base **224**, and it includes a junction body **236** which is permanently connected to an Edison lamp base or incandescent light bulb socket assembly **238** by means of a junction body stem **240** which is inserted into Edison lamp base **238**. Lamp base **238** is preferably an E26 lamp base and has external threads **242** which can be screwed into an incandescent bulb socket. Socket base **234** is permanently affixed to the rear part of housing base **224**.

Considering both exploded view of FIG. **41**, and FIGS. **42-46**, a further description of housing base **224** is now set forth. Housing base **224** has a relatively large cylindrical forwardly-extending central portion **244** protruding from a horizontal wall **246** as depicted in FIGS. **42** and **44**, and central portion **244** has a vertical wall **248** that is opposite to and parallel with a forwardly-extending interior wall **250**, the latter being the interior of the peripheral outer wall **226**. Forwardly-extending interior wall **250** extends from an outer edge portion **252**. Outer edge portion **252** is the edge of horizontal wall **246**. Horizontal wall **246**, vertical wall **248** and interior wall **250** form an annular housing base recess **254**. Protruding from the central part of central portion **244** is a smaller cylindrical central portion **256** having frusto-conical wall **258**. The forward part of central portion **244** is a flat annular face **260**, and the forward part of smaller cylindrical central portion **256** has a flat, generally-cylindrical face **262**.

A pair of holes **264** in the shape of church-keyholes are provided in face **260** for receiving mounting screws to attach LED light fixture **220** to an electric outlet box. A set of fastener holes **266** are provided in face **260**. A wire-holding slot **268** extends in central portion **244**, and a correspondingly aligned wire-holding slot **270** extends in smaller

cylindrical central portion 256. A set of interior tabs 272 are on the inside of rim 228. A set of fastener holes 274 are provided in face 260.

LED light fixture 220 incorporates a printed circuit board or light engine 276 and AC circuitry 278 for supplying alternating current for enabling the illumination of LEDs 280. Printed circuit board 276 is shown in both the exploded view of FIG. 41 and in FIG. 47.

Printed circuit board 276 has an inner imaginary ring 282 about a central longitudinal axis 284 and a concentric imaginary outer ring 286. Disposed on imaginary inner ring 282 are a series of LEDs 288, and another series of LEDs 290 are disposed in imaginary outer ring 286. Series of LEDs 288 and 290 are dispersed having different correlated color temperatures when illuminated, each color being part of a group which are illuminated according to the setting of a manually controllable CCT switching assembly discussed below. LEDs 290 are so arranged that when any particular LEDs with its particular CCT is switched on to be illuminated occurs. Each array of LEDs of a particular CCT can be arranged so that the illumination of the selected CCT illumination is uniform. LEDs 290 have also been arranged to have illumination characteristics besides being uniform as well. Printed circuit board 276 has a pair of holes 292 which are arranged to fit precisely over holes 264 in flat annular face 260 so that holes 264 and 292 overly each other to enable access to the respective holes by the mounting screws for securing fixture 192 to an outlet box. A set of holes 338 are provided in printed circuit board for receiving screws 336 to attach printed circuit board 276 to face 260 of central portion 244, as explained below, extends through printed circuit board 276.

LED light fixture 220 has a forward side 296 and a rearward side 298 when it is attached to a ceiling. Referring to FIG. 44 which is a rearward view of bottom cover 224, annular housing base recess 254 extends around central portion 244. A pair of slots 299 and 301 extends through horizontal wall 246 and can be seen in FIGS. 42, 43 and 44. Slot 301 renders a manually operable CCT switch assembly 302 actuatable by a person standing beneath the ceiling on which flush mount light fixture 220 is mounted. The entire body of LED light fixture 220 is a concealment to CCT switch assembly 302, and light fixture 220 must be removed from the socket on the ceiling to render CCT switch assembly 302 observable and accessible for operation. CCT switch assembly 302 is shown in exploded view in FIG. 41 and is composed of a switch components 304. Switch assembly 302 is attached by means of screws 308 to horizontal wall 246 and has a slide extending through slot 301 which is manually actuatable while light fixture 220 is not attached to an Edison socket attached to a ceiling. Alternatively, switch assembly 302 can be rendered accessible by a person by rendering it available by the simple removal of diffuser 222 as was done with the embodiments shown in FIGS. 25-37.

Manually operated CCT switch assembly 302 is fixedly attached to horizontal wall 246. The setting of CCT assembly 302 can be changed by changing the location of the slide of CCT switch assembly 302 by the manual movement of slide (not shown) that extends through slot 301 which is accessible once diffuser 722 has been removed as explained below. As indicated previously, the different correlated card color temperatures can be selected any range of values, but all as also indicated previously an advantageous setting is one of 3000K, 4000K and 5000K. These are all noted on a setting scale 301 shown in FIG. 44 which can be virtually identical to setting scales 60 and 140 discussed previously.

Referring back to the exploded view of FIG. 41 and further to FIGS. 48-50, another portion of the structure of LED light fixture 220 is a loop 322. Loop 322 is a cylindrical tube having a cylindrical wall 324 having at one end a partial annulus 326 in the form of a radial arc which is preferably integral with cylindrical wall 324, perpendicular to wall 324 and concentric with wall 324. Partial annulus 326 has three equiangular tabs 328. Each tab has a screw hole 330, each having a cylindrical axis which is parallel with the axis of loop 322. Annulus 326 terminates at opposing ends 331 to define a gap 332.

Loop 322 is attached to horizontal wall 246 of bottom cover 224 by means of a set of screws 333 which extend through screw holes 330 and into screw holes 334 in horizontal wall 246 to render loop 322 concentric with peripheral outer wall 226. Loop 322 and peripheral outer wall 226 of bottom cover 224 define between them an annular recess which is concentric with each of peripheral wall 324 of loop 322 and peripheral outer wall 226. Gap 332 in loop 322 provides an access to horizontal wall 246 wherein switch 304 is secured to horizontal wall 246. By the foregoing arrangement, loop 322 is secured to housing base 224, and switch assembly 302 is attached to horizontal wall 246.

Referring to FIG. 41, printed circuit board 290 is secured to housing base 224 by means of a screw 336 which extends through a screw hole 294 in printed circuit board 276, and into a screw hole in central portion 244.

In order to protect printed circuit board 290, a protective cap 342 shown in FIG. 41 is secured to printed circuit board 290 and to central portion 244 of housing base 224. Protective cap 342 is preferably a rigid, clear plastic unitary structure having a generally flat upper portion 344 with a uniformly curved periphery 346. Protective cap 342 is secured to central portion 244 by means of screws 348 which extend through equiangularly spaced screw holes 350 extending through portion 344, through screw holes 352 in printed circuit board 290, and thereafter screwed in tightly into screw holes 354 in central portion 244 of housing base 224.

FIGS. 51 and 52 depict a compartment for a manually actuatable CCT switch according to the invention, including the manually actuatable portion. Illustrated are a portion of an LED light fixture 356 (which could be any LED light fixture according to the invention) having a manually operable CCT switch assembly 358 (which could be any such CCT switch assembly falling within the scope of the invention) and a releasable latching assembly 360 (also within the scope of the invention). The manually actuatable CCT switch assembly 358 will not be discussed at this time, since it was discussed previously and references made thereto.

Releasable latching assembly 360 further includes a closure 362 composed of a door 364 which is mounted to a housing or base 366 by means of a hinge assembly 368. Hinge assembly 368 can be a simple barrel hinge assembly having a pair of barrels 370 that are affixed to door 364, and a hinge pin 372 affixed to housing 366 and about which door 364 pivots. A latch assembly 374 includes a male latching member 376 extending from door 364 and having extending from it flanges 378. A female latching member 380 having biased catches 381 extends from a recess 382 and base 366, and recess 382 extends further back from the surface of base 366 from a larger recess. Female latching member 382 is in the line of swing of male latching member 376 and flanges 378 are engaged by members 380 when door 364 is moved to the closed position as shown in FIG. 51. As door 364 moves to its closed position, male latching member 376

15

pushes female latching member 380 into recess 382, and the frame of recess 382 urges catches 381 against male latching member 376 and behind flanges 378 to releasably retain male latching member 376 in recess 382 and hold door 364 in the closed position. An appropriate handle 384 can be grasped by the user's fingers to open door 364 and withdraw female latching member 380 from recess 382. Catches 381 are biased to their open positions, to release flanges 378 to enable the user to open door 364 and enable the user's fingers to change the setting of CCT switch assembly 358.

The invention has been described in detail with particular emphasis on the preferred embodiments thereof, but variations and modifications may occur to those skilled in the art from the preceding discussion and from the following claims.

The invention claimed is:

1. An LED light fixture comprising:

at least two [electrically operated] LED light sources for emitting illumination, *said at least two LED light sources being electrically operated and the illumination of each of said at least two LED light sources having different, predetermined correlated color temperatures; and*

an electric circuit connectable to an electric power source for supplying electric power to [one of the group consisting of] a selected [one of said at least two LED light sources and a selected] combination of said at least two LED light sources, said electrical circuit comprising:

a switching circuit operable for connecting said selected [one of the group consisting of a selected one of said at least two LED light sources, and said] combination of said at least two LED light sources, to said electrical circuit to receive electrical current and emit illumination of a predetermined correlated color temperature;

a manually controllable correlated color temperature switching assembly to operate said switching circuit to connect said selected one of said [group] *at least two light sources and said selected combination of said at least two light sources* to the electric power source to effect the illumination of said selected one of said group of one of said at least two LED sources and a combination of said at least two LED light sources, said manually controllable correlated color temperature switching assembly including a digitally operated switch actuating member for actuating said manually controllable correlated color temperature switching assembly;

a switch holding structure for holding for operation said digitally operated switch actuating member; and [a concealment for concealing said switch holding structure to render said digitally operated switch actuating member inaccessible for operation, and for selectively rendering said digitally operated switch actuating member accessible for digital operation]

a removable diffuser for diffusing and transmitting light emitted by said at least two electrically operated LED light sources, said removable diffuser being removably attached to said LED light fixture for preventing access to said digitally operated switch actuating member, said removable diffuser being removed from said light fixture to provide access to said digitally operated switch actuating member for a user to digitally operate said digitally operated switch actuating member.

2. An LED light fixture according to claim 1 and further comprising [an electronics] *a light module for cooperating*

16

with said removable diffuser to form a container for holding and rendering accessible said digitally operated switch actuating member;

wherein said [concealment] *container* comprises an LED light fixture receptacle for releasably holding said LED light fixture to render said digitally operated switch actuating member inaccessible for operation, and [for enabling the release of said LED light fixture] *wherein the removal of said removable diffuser* from said [receptacle to render] *LED light fixture renders* said digitally operated switch actuating member accessible for operation.

3. An LED light fixture according to claim 2 wherein said LED light fixture is a downlight, and said LED light fixture receptacle is a can.

4. An LED light fixture according to claim 1 wherein said LED light fixture further comprises:

a cover support; and [a] *wherein said removable diffuser is* removably attachable to said cover support;

wherein said digitally operative switch attachment member is operatively attached to said cover support; and [wherein said concealment comprises:

said cover support;

said diffuser; and]

attachment structure for cooperating with said cover support and said diffuser for selectively attaching said diffuser to said cover support [to conceal said digitally operated switch actuating member], and to selectively detach said diffuser from said cover support to render said digitally operated switch actuating member accessible for operation.

5. An LED light fixture according to claim 4 wherein said cover support, said diffuser and attachment structure each comprise a selected one of the group consisting of cooperating screw threads on said cover support and said diffuser, and cooperating screw and screw hole assembly on said cover support and said diffuser, both to enable the attachment of said diffuser to said cover support and to enable the detachment of said diffuser from said cover support.

6. An LED light fixture according to claim 4 [wherein said concealment comprises] *and further comprising:*

bracketing assembly for removably bracketing said diffuser and said cover support [together to conceal] *to render* said digitally operative switch actuating member *inaccessible for operation*, and for unbracketing said diffuser from said cover support *to enable the removal of said diffuser* to render said digitally operated switch actuating member accessible for operation.

7. An LED light fixture according to claim 4 wherein LED light fixture includes a forward portion and a rearward portion, and said rearward portion is proximal a ceiling is when said LED light fixture is mounted for operation to the ceiling and said LED light fixture further comprises a rearward side;

and wherein said [concealment] *LED light fixture further* comprises:

a digitally operative switch actuating member support structure for supporting said digitally operated switch actuating member located at said rearward side, said digitally operated switch actuating member being [inaccessible for operation when said LED light fixture is mounted for operation to the ceiling, and said digitally operated switch actuating member being] accessible for operation in response to the demounting of said LED light fixture from the ceiling.

17

8. An LED light fixture according to claim 1 wherein said manually controllable correlated color switching assembly comprises:

a slide switch including:

an indicator for indicating particular correlated color temperatures to assist in the determination of a correlated color temperature; and

a manually operated slide slidable along said indicator to select a particular correlated color temperature operatively connected to said switching circuit and to operate said switching circuit to effect the selection of the particular correlated color temperature.

9. An LED light fixture according to claim 1 wherein said switch holding structure [is] further comprises a switch holding compartment alternating between a non-accessible condition for preventing access by a user's fingers to said digitally operated switch actuating member, and an accessible condition for enabling access by a user's fingers to operate said digitally operated switch actuating member.

10. An LED light fixture according to claim 1 and further comprising at least one printed circuit board, and wherein so said at least two electrically operated LED light sources comprise:

at least two sets of LEDs, each set of LEDs having a predetermined correlated color temperature that is different from the respective predetermined correlated color temperature of the remaining sets of LEDs; and wherein said respective sets of LEDs are each operatively attached to said at least one printed circuit board, said manually controllable correlated color temperature switching assembly being manually switchable to a selected one of the group consisting of one of said sets of LEDs and a combination of said sets of LEDs, each of said sets of LEDs and said combination of sets of LEDs having a predetermined correlated color temperature different from the correlated color temperature of the other sets and combination of said sets, for emitting illumination of the predetermined correlated color temperature.

11. An LED light fixture according to claim 1 wherein said LED light fixture comprises a fan LED light kit, said fan LED light kit comprising:

a cover support located proximal a ceiling when said fan LED light kit is mounted for use; and

a light transmitting cover removably attachable to said cover support and being distal the ceiling when said [fan LED] digitally operated switch actuating member is mounted for use between said cover support and said cover when said cover is attached to said cover support; wherein said manually controllable correlated color temperature switching device is operatively attached to said cover support [and disposed on said electric container] when said cover is attached to said cover support; and

wherein said [concealment] LED light fixture further comprises:

attachment structure for cooperating with said cover support and said light transmitting cover for selectively attaching said light transmitting cover to said cover support [to conceal said digitally operated switch actuating member], and to selectively detach said light transmitting cover from said cover support to render said digitally operative switch actuating member accessible for operation.

12. An LED light fixture according to claim 11 wherein said fan LED light kit further comprises:

18

at least two printed circuit board adapters, each of said at least two printed circuit board adapters including at least one LED light source, each of said at least one LED light source having a different correlated color temperature different from the correlated color temperature of each of said LED light sources included on the other at least two printed circuit board adapters.

13. An LED light fixture according to claim 1 wherein said manually controllable correlated color temperature switching assembly is selected from the group consisting of a slide switch, a toggle switch, a single pole double throw switch, a double pole, double throw switch, a rotary switch and a DIP switch.

14. An LED light fixture according to claim 1 and further comprising:

a base for holding said manually controllable correlated color temperature switching assembly, wherein said base is proximate a ceiling when said LED light fixture is in use, and said base includes a slot wherein said digitally operated switch actuating member extends through said slot; and said base including a configuration to render said digitally operated switch actuating member inaccessible when LED light fixture is in use; wherein said concealment comprises said configuration of said base.

15. An LED light fixture according to claim 14 wherein said base is located at one end of said LED light fixture, and [wherein said concealment includes] further including:

a hollow diffuser releasably mountable on said base to cover and render said manually operable correlated color temperature switch inaccessible;

said hollow diffuser being detachable from said base to provide access to said manually controllable correlated color temperature switch to enable a person to operate said manually controllable switch actuating member.

16. An LED light fixture according to claim 15 wherein said base and said hollow diffuser cooperate to form a housing for said at least two LED light sources and said electric circuit.

17. An LED light fixture according to claim 1 wherein said LED light fixture further comprises:

a base located at one end of said light fixture and being attachable to a ceiling;

a diffuser located at another end of said light fixture distal from the ceiling and operatively attachable to said base when said LED light fixture is in use; and

at least one releasable bracket having a closed position for securing said diffuser to said base, and an open position for releasing said diffuser from said base to render said digitally operated switch actuating member accessible; wherein said concealment comprises said base, said diffuser and said at least one releasable bracket.

18. An LED light fixture according to claim 1 wherein said manually controllable correlated color temperature switching assembly is selected from the group consisting of a slide switch, a toggle switch, single pole single throw toggle switch, single pole double throw switch, double pole double throw switch, a rotary switch, a three pole four way rotary switch, dual in-line package switch, a push button switch, a push-to-make switch and a push-to-break switch.

[19. An LED light fixture comprising:

at least one printed circuit board;

an electrical circuit at least partially disposed on said printed circuit board, said electrical circuit including:

at least two groups of LEDs mounted on said printed circuit board, each of said at least two groups of LEDs emitting illumination of particular correlated

19

color temperature different from the correlated color temperature of said other of said at least two groups of LEDs in response to receiving electric power; at least two subcircuits, each of said at least two subcircuits including a different one of said at least two groups of LEDs, and electrical switching components for each of said at least two subcircuits, said electrical switching components being alternately actuatable for connecting the group of LEDs in said subcircuit to electrical power in response to the actuation of said electrical switching components in said subcircuit that said group of LEDs being connected is disposed; and a manually controllable correlated color temperature switching assembly manually actuatable to actuate a selected one of said electrical switching components to connect a selected group of LEDs to electrical power to cause said selected group of LEDs to emit illumination of the particular correlated color temperature of said selected group of LEDs.]

[20. An LED light fixture according to claim 19 wherein said manually controllable correlated color temperature switching assembly is a manually slideable slide switch, and said electrical switching components of said at least two subcircuits are selectively actuatable by said slide switch to effect the transmission of electrical power to said group of LEDs in said selected subcircuit.]

[21. An LED light fixture according to claim 19 wherein said manually controllable correlated color temperature switching assembly is selected from the group consisting of a slide switch, a toggle switch, a single pole double throw switch, a double pole double throw switch, a rotary switch and a DIP switch.]

[22. An LED light fixture according to claim 19 wherein said at least two groups of LEDs emit illumination of correlated color temperatures of respectively 3000K, 4000K and 5000K.]

[23. An LED light fixture according to claim 19 wherein said LED light fixture includes a light module, said light module comprising:

said at least one printed circuit board;
a heat sink adjacent said printed circuit board for absorbing heat generated by said at least two groups of LEDs; and
said manually controllable correlated color temperature switching assembly.]

[24. An LED light fixture comprising:

a housing assembly;
at least one printed circuit board operatively attached to said housing assembly;
at least two sets of LED light sources mounted on said at least one printed circuit board, each of said sets of at least two LED light sources having a correlated color temperature different from the correlated color temperature of every other of said sets of LED light sources;
an electric circuit operable to supply electricity to said at least two sets of LED light sources;
a manually controllable correlated color temperature switch for selectively connecting said electric circuit to a selected one of said sets with LED light sources to actuate said selected one of said sets with LED light sources to effect the selective illumination of said at least one LED in said selected one of said sets of LED light sources to emit illumination of the color correlated temperature of said selected one with said sets of LED light sources, said manually operated switch being

20

operatively attached to said housing and comprising a digitally operable actuating member to effect the selection of one of the sets of LED light sources; and a diffuser operatively attachable to said housing assembly for transmitting illumination from said selected set of LED light sources to a space remote from said LED light fixtures.]

[25. An LED light fixture according to claim 23 wherein said actuating member is not readily observable and not accessible for operation when said actuating member is not ready for use, and said LED light fixture comprises structure for rendering said actuating member readily observable accessible for use.]

26. An LED light fixture [according to claim 24] comprising:

a housing assembly;
at least one printed circuit board operatively attached to said housing assembly;
at least two sets of LED light sources mounted on said at least one printed circuit board, each of at least two said sets of LED light sources having a correlated color temperature different from the correlated color temperature of every other of said sets of LED light sources;

an electric circuit operable to supply electricity to said at least two sets of LED light sources wherein said electric circuit comprises at least two subcircuits, each of said at least two subcircuits including one of said sets of LED light sources, said subcircuits being mounted on said at least one printed circuit board; [and]

[said] a manually controllable correlated color temperature switch [is] selectively connectable to one or a combination of said subcircuits to actuate the selected one of the group consisting of said set of LED light sources in said selected subcircuit and the selected set of LED light sources in said combination of said subcircuits[.]; and

[wherein said] a digitally operable actuating member [makes said] for making a selective connection of said manually controllable correlated color temperature switch.

27. An LED light fixture according to claim 26 wherein said at least two subcircuits and manually controllable correlated color temperature switch are mounted on at least one printed circuit board.

28. An LED light fixture according to claim 27 wherein said LED light fixture is a downlight, and wherein:

said housing assembly comprises:
a light module including:
a light module housing;
wherein said at least one printed circuit board is mounted on said light module housing.

29. An LED light fixture according to claim 28 wherein said light module further includes:

a truncated heat sink comprising a relatively narrow end portion and a relatively wide opposite end portion for transmitting illumination from said LED light fixture; a box for containing said manually controllable correlated color temperature switch;
wherein said at least one printed circuit board is proximal said narrow end portion for emitting illumination from said LED light sources through said relatively wide end portion of said truncated heat sink.

30. An LED light fixture according to claim 29 wherein said box for [electrical components] containing said manually controllable correlated color temperature switch has an opening through which opening said digitally operated

21

switch extends, and wherein said module further comprises an indicator indicating the specific correlated color temperatures to which said digitally operable [switch] *actuating member* is settable to select the selectable one of the group consisting of said LED light source in said selected subcircuit and the selected LED light sources in said combination in said subcircuits.

31. An LED light fixture according to claim 29 wherein said box for [electrical components] *containing said manually controllable correlated color temperature switch* is proximal said narrow end portion of said truncated heat sink and distal said wide end portion of said truncated heat sink.

32. An LED light fixture according to claim [24] 26 wherein said manually controllable correlated color temperature switch is a slide switch.

33. An LED light fixture according to claim [24] 26 wherein said LED light fixture is a ceiling light fixture, and *further comprising a diffuser attached to said housing assembly for diffusing and transmitting light emitted by said at least two sets of light sources; and*

[wherein said LED light fixture is a ceiling light fixture, and]

wherein said housing assembly comprises a base for being attached to a ceiling for connection to an electric power source, said base including on outside edge portion; wherein said at least one printed circuit board and said manually operated correlated color temperature switch are operatively attached to said base;

22

wherein said diffuser has an outside diffuser edge portion that is operatively attachable to and selectively detachable from said outside edge portion of said base; wherein said ceiling light fixture further comprises:

a manually controllable correlated color temperature switch holder for containing at least:

a portion of said manually operated correlated color temperature switch; and

a blocking structure for selectively blocking manual access to said digitally operable actuating member;

wherein said manually controllable correlated color temperature switch holder provides access to a user's hand to operate said digitally operable actuating member when said blocking structure does not block said manually operable actuating member to prevent the user's hand from operating said actuating members.

34. An LED light fixture according to claim [24] 26 wherein said at least two sets of LED light sources are mounted on said at least one printed circuit board in a predetermined arrangement to provide a predetermined area of illumination for each of said at least two sets of LED light sources.

35. An LED light fixture according to claim 34 wherein said predetermined arrangement provides a uniform area of illumination for each of said at least two sets of LED light sources.

* * * * *