

US00RE49025E

(19) **United States**
(12) **Reissued Patent**
Dal Dosso et al.

(10) **Patent Number:** **US RE49,025 E**
(45) **Date of Reissued Patent:** **Apr. 12, 2022**

(54) **SIDE-SHIFT LIMITER**

(56)

References Cited

(71) Applicant: **Cascade Corporation**, Portland, OR (US)
(72) Inventors: **Andrea Dal Dosso**, Verona (IT); **Pat S. McKernan**, Portland, OR (US); **D. Clark Jordan**, Boring, OR (US); **Gregory A. Nagle**, Portland, OR (US); **David W. Petronek**, Boring, OR (US)
(73) Assignee: **Cascade Corporation**, Fairview, OR (US)

U.S. PATENT DOCUMENTS

2,967,717 A * 1/1961 Track B06G 11/26
137/456
3,166,207 A 1/1965 Quayle
3,241,697 A * 3/1966 Rogant B66F 9/147
414/666
3,738,520 A 6/1973 Dittel et al.
3,990,594 A 11/1976 Olson et al.
4,543,031 A 9/1985 Luebrecht et al.
4,849,735 A * 7/1989 Kirtley B66F 17/003
180/167
5,052,882 A 10/1991 Blau et al.
5,088,880 A 2/1992 Field, Jr.

(21) Appl. No.: **15/950,978**

(22) Filed: **Apr. 11, 2018**

(Continued)

Related U.S. Patent Documents

FOREIGN PATENT DOCUMENTS

Reissue of:
(64) Patent No.: **9,309,099**
Issued: **Apr. 12, 2016**
Appl. No.: **14/309,933**
Filed: **Jun. 20, 2014**

CA 2651695 A1 11/2007
DE 2810893 A1 9/1979
(Continued)

OTHER PUBLICATIONS

(51) **Int. Cl.**
B66F 9/24 (2006.01)
B66F 9/075 (2006.01)
B66F 9/12 (2006.01)
B66F 9/14 (2006.01)
B66F 9/18 (2006.01)
B66F 17/00 (2006.01)

English translation of JP-2000072396-A.*
(Continued)

Primary Examiner — Peter C English
(74) *Attorney, Agent, or Firm* — Chernoff, Vilhauer, McClung & Stenzel, LLP

(52) **U.S. Cl.**
CPC **B66F 9/24** (2013.01); **B66F 9/0755** (2013.01); **B66F 9/125** (2013.01); **B66F 9/146** (2013.01); **B66F 9/183** (2013.01); **B66F 17/003** (2013.01)

(57) **ABSTRACT**

A side shift limiting attachment for a material handling vehicle alerts the vehicles operator and restricts side shifting, lifting, tilting and/or rotation of the attachment when the side shift displacement is approaching or has reached a limit for a lift height.

(58) **Field of Classification Search**
CPC **B66F 17/003**; **B66F 9/24**; **B66F 9/0755**; **B66F 9/183**; **B66F 9/146**; **B66F 9/143**; **B66F 9/125**

See application file for complete search history.

31 Claims, 7 Drawing Sheets

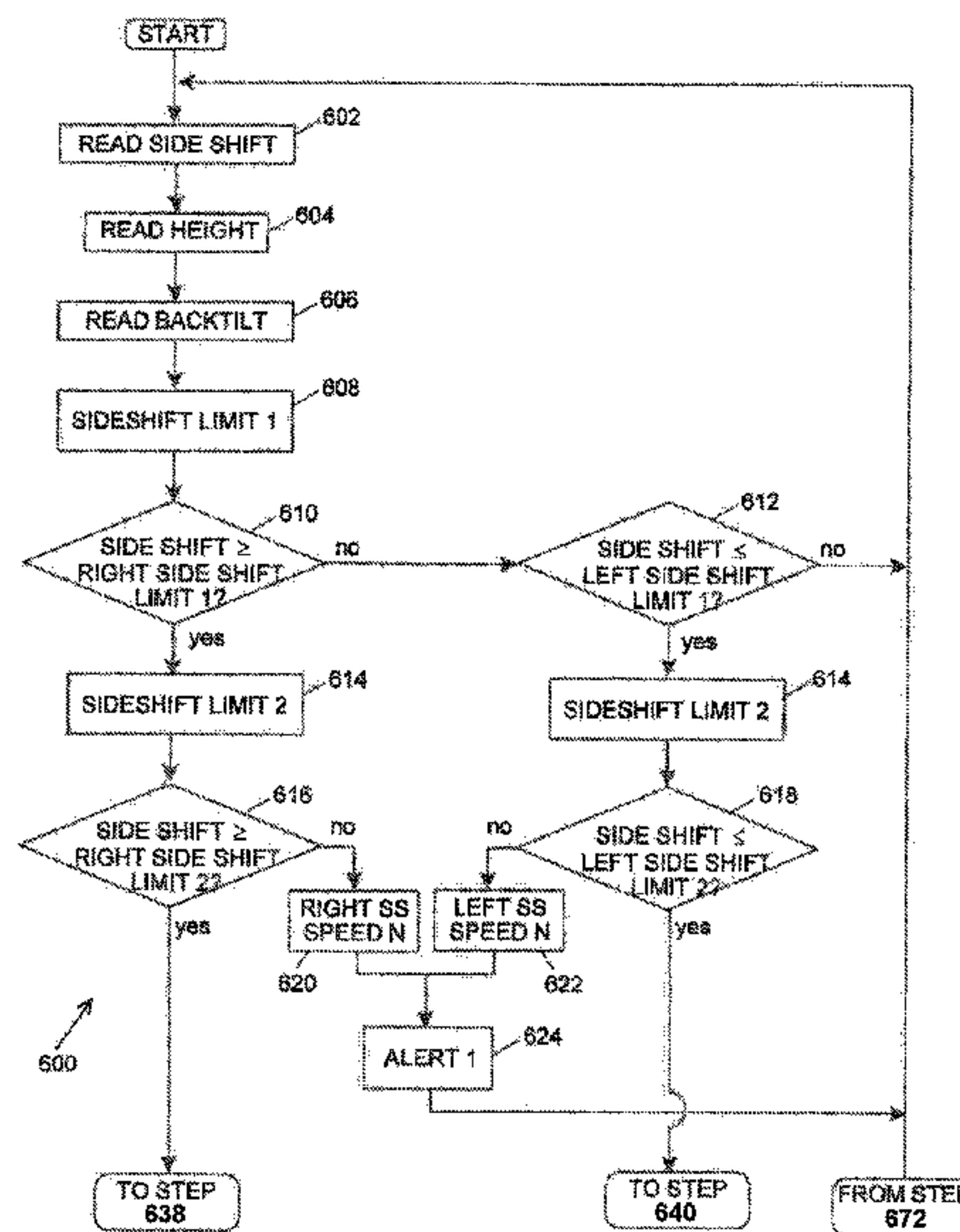

Amended

US RE49,025 E

Page 2

(56)

References Cited

U.S. PATENT DOCUMENTS

5,336,039	A	8/1994	House	
5,749,696	A *	5/1998	Johnson	B66F 9/082 187/393
5,927,932	A	7/1999	Seaberg	
6,056,503	A	5/2000	Way et al.	
6,834,574	B2	12/2004	Neumann	
7,018,159	B2	3/2006	Jordan et al.	
7,165,652	B2	1/2007	Allerding et al.	
7,287,625	B1	10/2007	Harris	
8,078,315	B2	12/2011	McKernan et al.	
8,140,228	B2	3/2012	McCabe et al.	
8,403,618	B2	3/2013	Prentice et al.	
8,466,380	B2 *	6/2013	Inoue	G01G 13/08 177/145
2004/0015328	A1	8/2004	Wargon	
2004/0153283	A1 *	8/2004	Wargon	A22C 17/0013 702/156
2004/0154871	A1	8/2004	Allerding et al.	
2006/0115354	A1	6/2006	Prentice et al.	
2006/0130474	A1	6/2006	Segerljung	
2006/0232025	A1	10/2006	Braud	
2009/0272257	A1	11/2009	Petronek	
2010/0162660	A1 *	7/2010	Jaconelli	B65B 9/14 53/399
2011/0236148	A1 *	9/2011	Anderson	B60P 3/077 410/30
2012/0101684	A1	4/2012	Takazato	
2012/0107077	A1	5/2012	Alveteg	
2012/0171004	A1 *	7/2012	Jones, Jr.	B66F 9/22 414/664
2012/0175323	A1 *	7/2012	Ceron Garcia	B65D 85/30 211/41.1
2013/0020391	A1 *	1/2013	Olmstead	G06K 7/10722 235/438

2013/0020392	A1 *	1/2013	Olmstead	G06K 7/10722 235/440
2013/0182237	A1	7/2013	Viereck et al.	
2013/0205610	A1	8/2013	Wildner	
2013/0211679	A1	8/2013	Gerdes et al.	
2013/0277584	A1	10/2013	McKernan et al.	
2013/0293365	A1	11/2013	Ascencio	
2014/0219758	A1 *	8/2014	Soder	B66F 9/146 414/639
2014/0219759	A1 *	8/2014	Soder	B66F 9/146 414/664
2014/0219760	A1 *	8/2014	Soder	B66F 9/146 414/664

FOREIGN PATENT DOCUMENTS

EP	0489255	A1	6/1992
EP	0291021	A2	6/1999
EP	0921021	A2	6/1999
EP	1203745	A1	5/2002
EP	1447377	A1	8/2004
EP	2527288	A1	11/2012
JP	S58-6900	A	1/1983
JP	2000072396	A *	3/2000
JP	2010-23941	A	2/2010
WO	81/02001	A1	7/1981
WO	WO 81/02001		7/1981
WO	199502552	A1	1/1995
WO	2002094517	A1	11/2002

OTHER PUBLICATIONS

Installation & User Manual, Sideshift Limit Kit 6836800, Cascade Corporation, 2013, 12 pgs.
 International Search Report and Written Opinion issued in application No. PCT/US15/16662, dated May 29, 2015, 7 pgs.

* cited by examiner

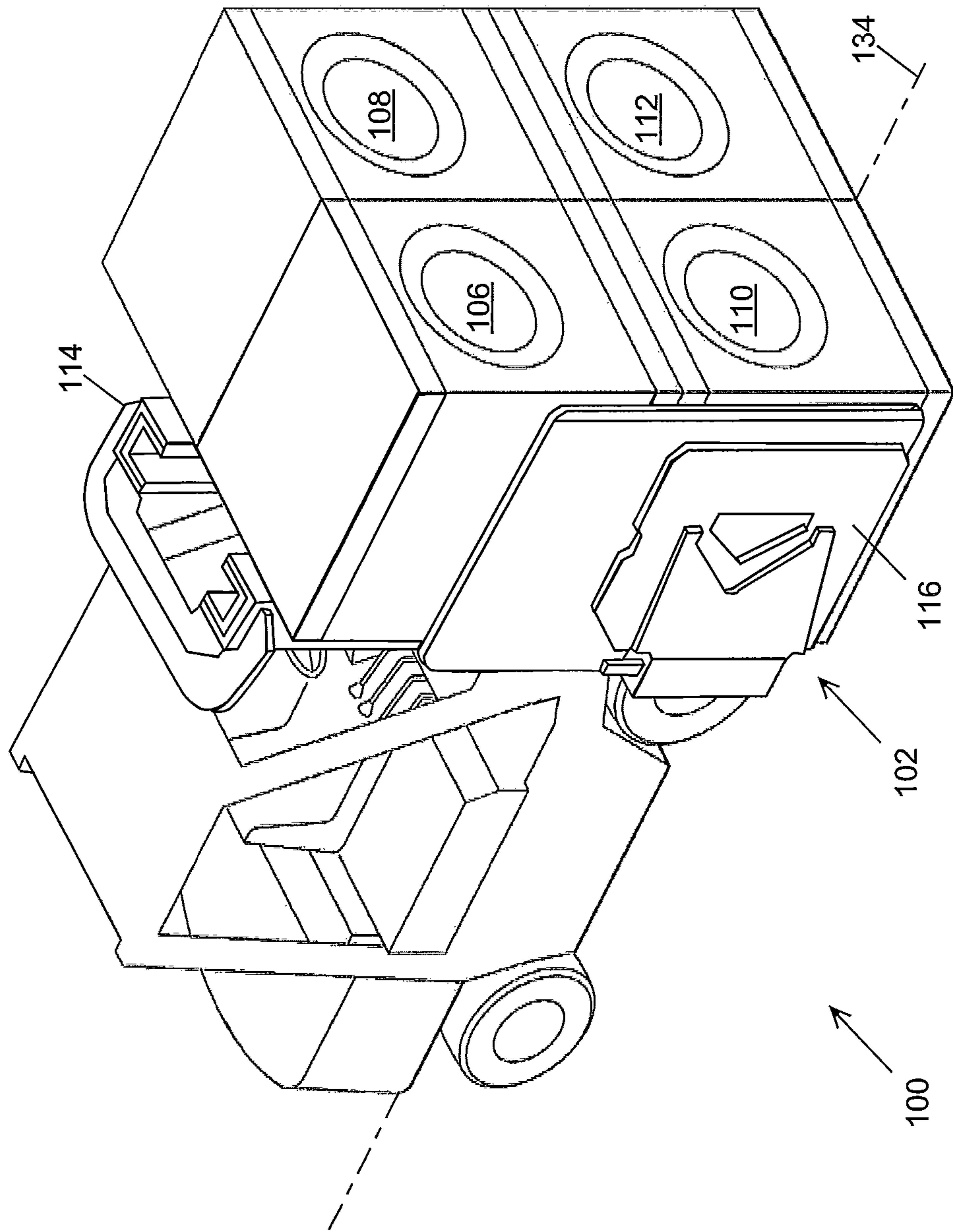

FIG. 1

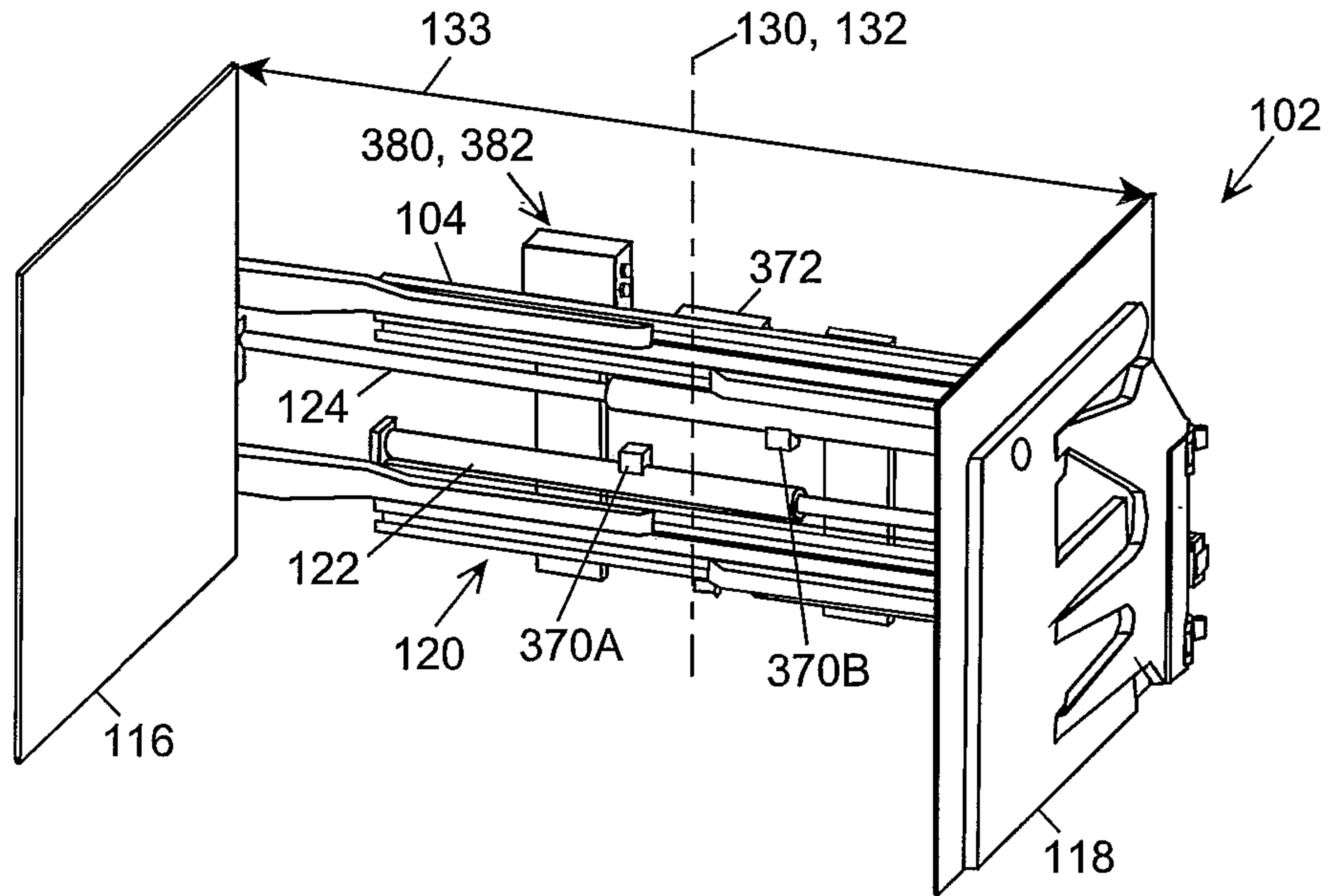

FIG. 2

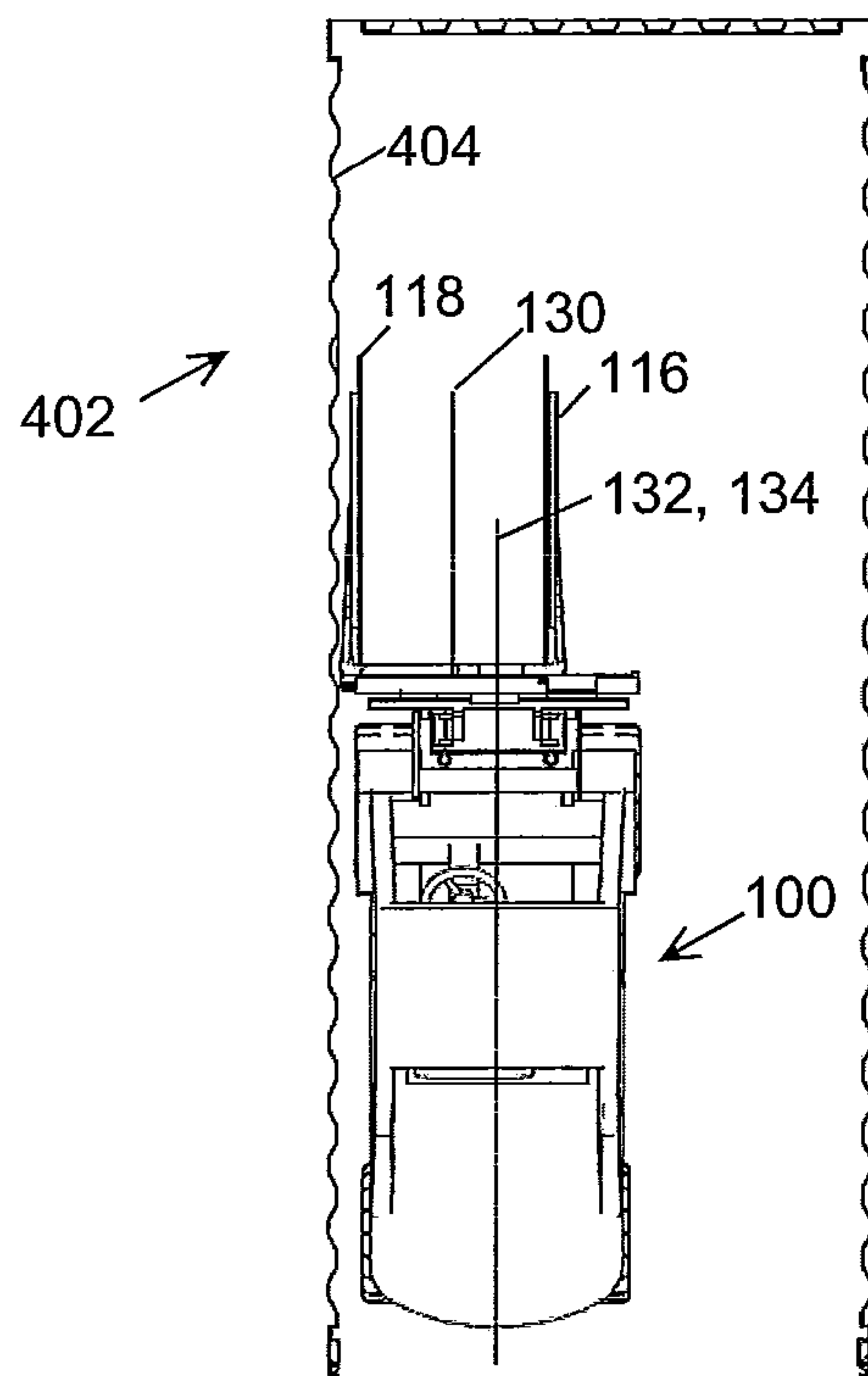

FIG. 4

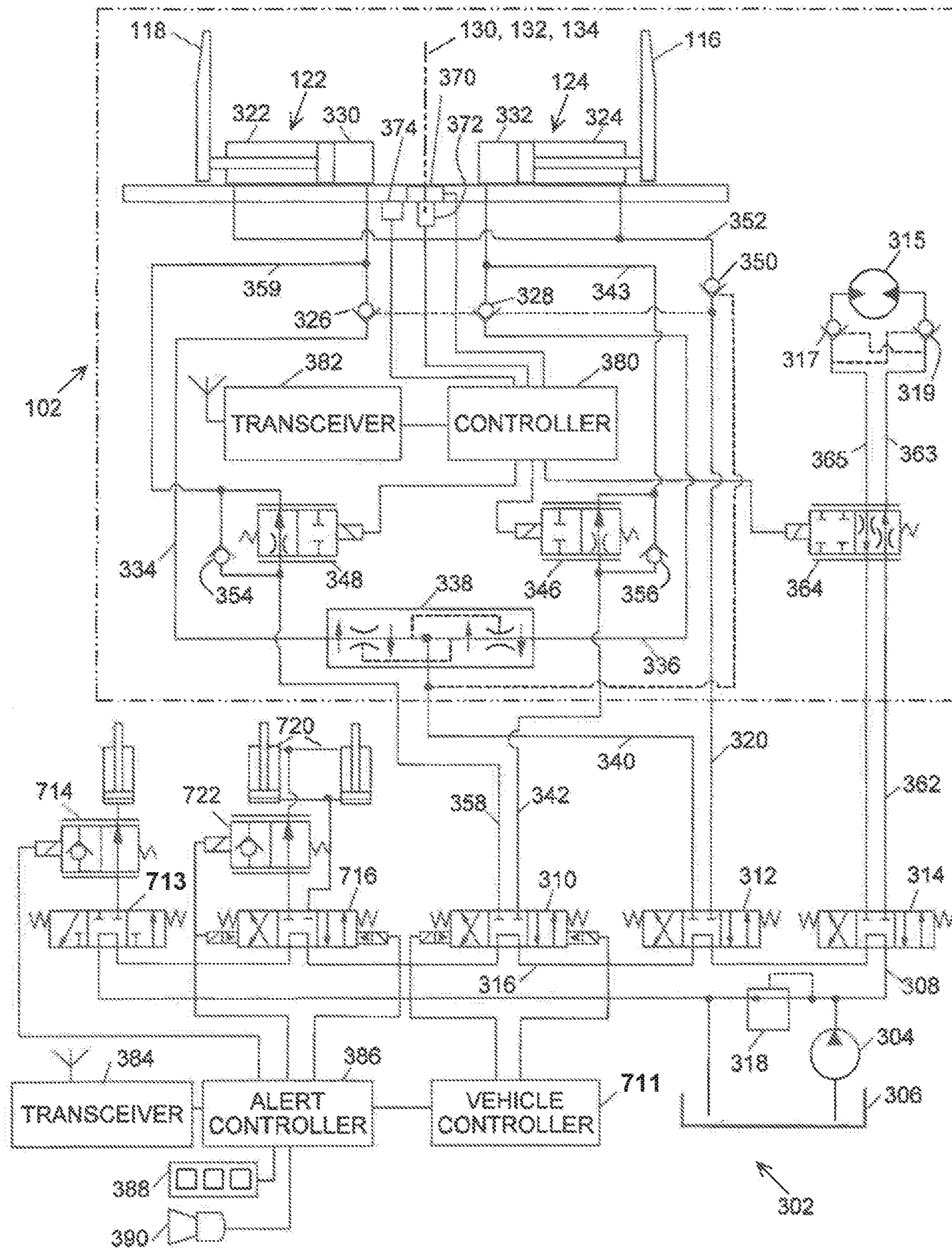

FIG. 3 Amended

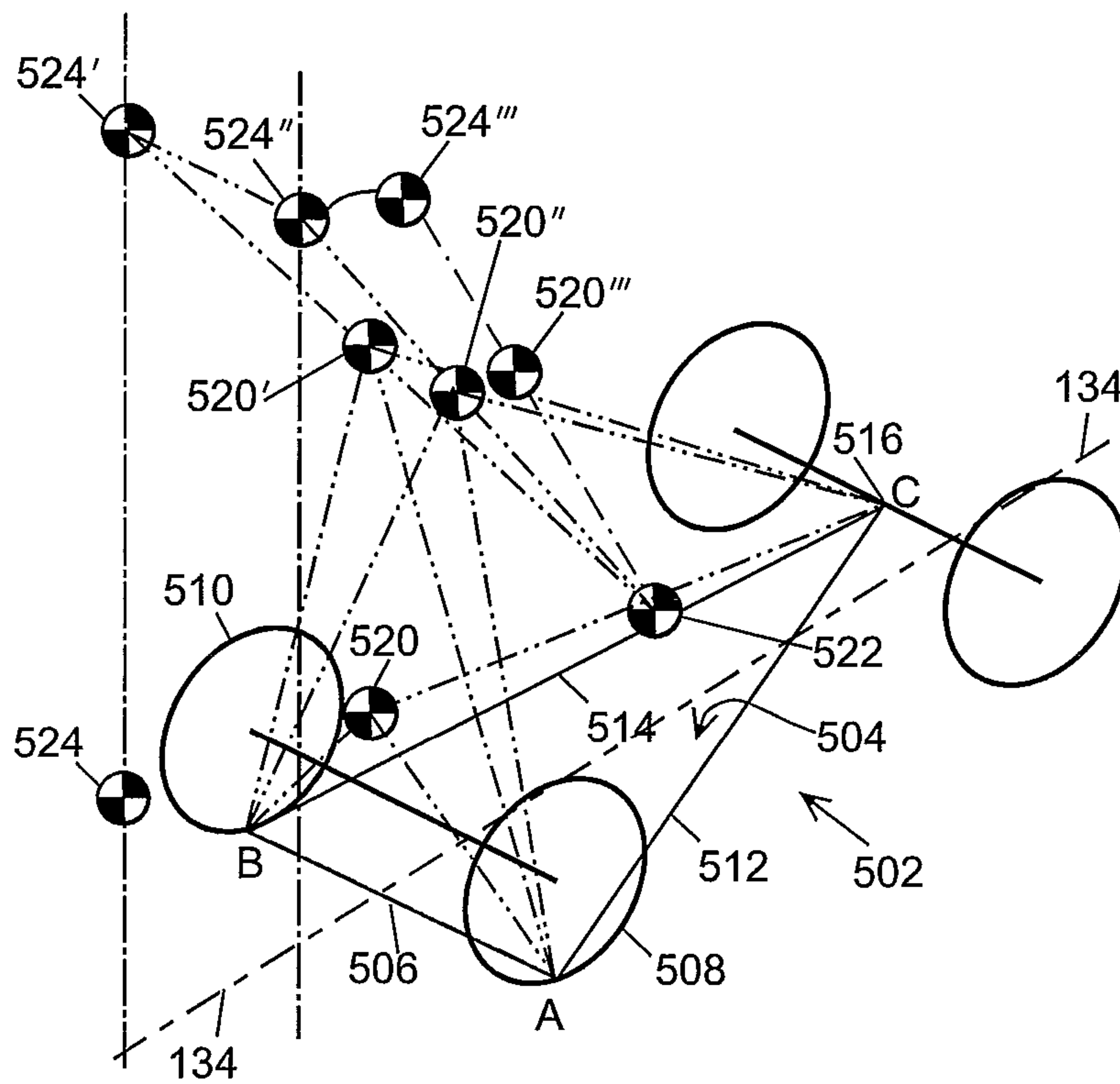

FIG. 5

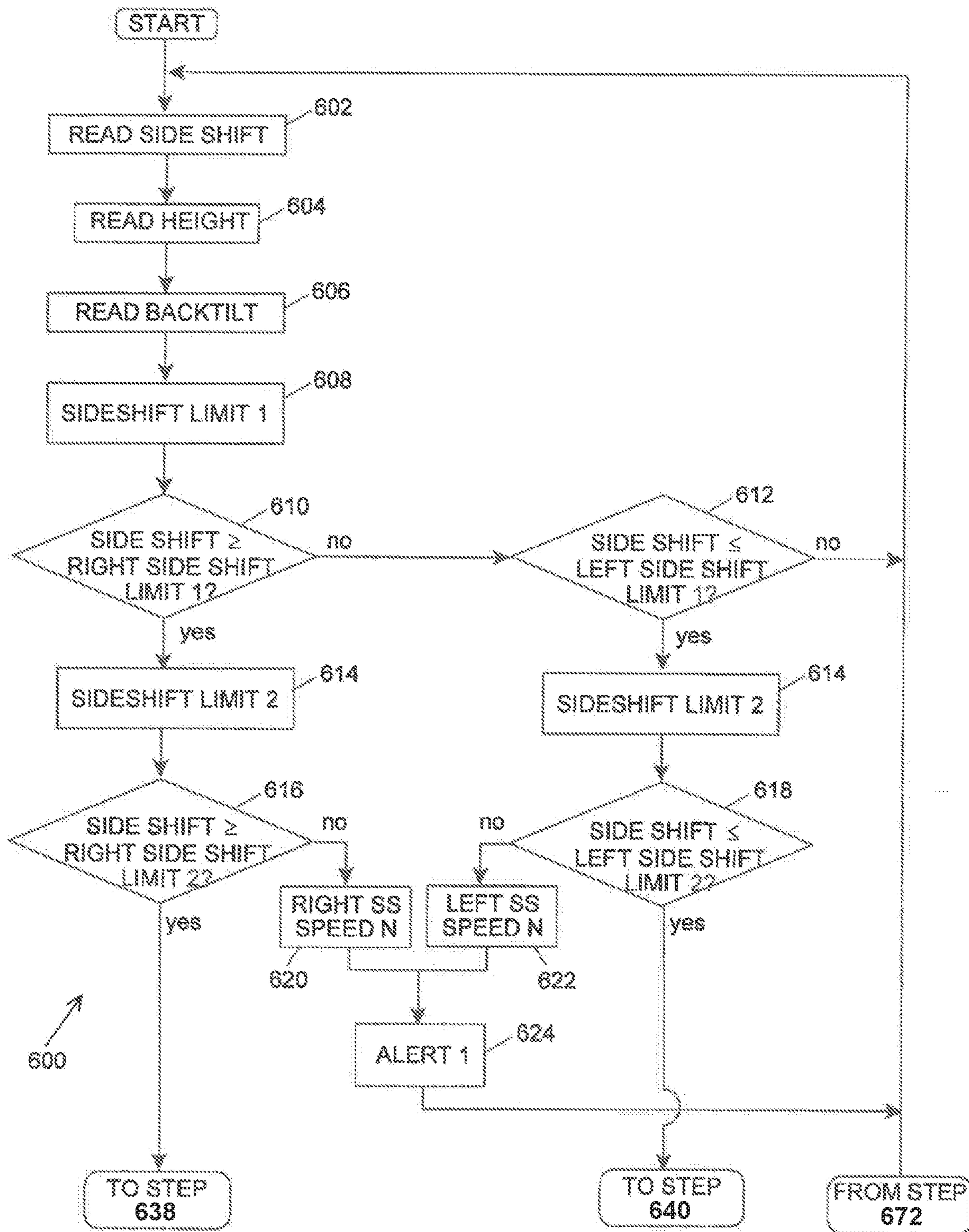

FIG. 6A Amended

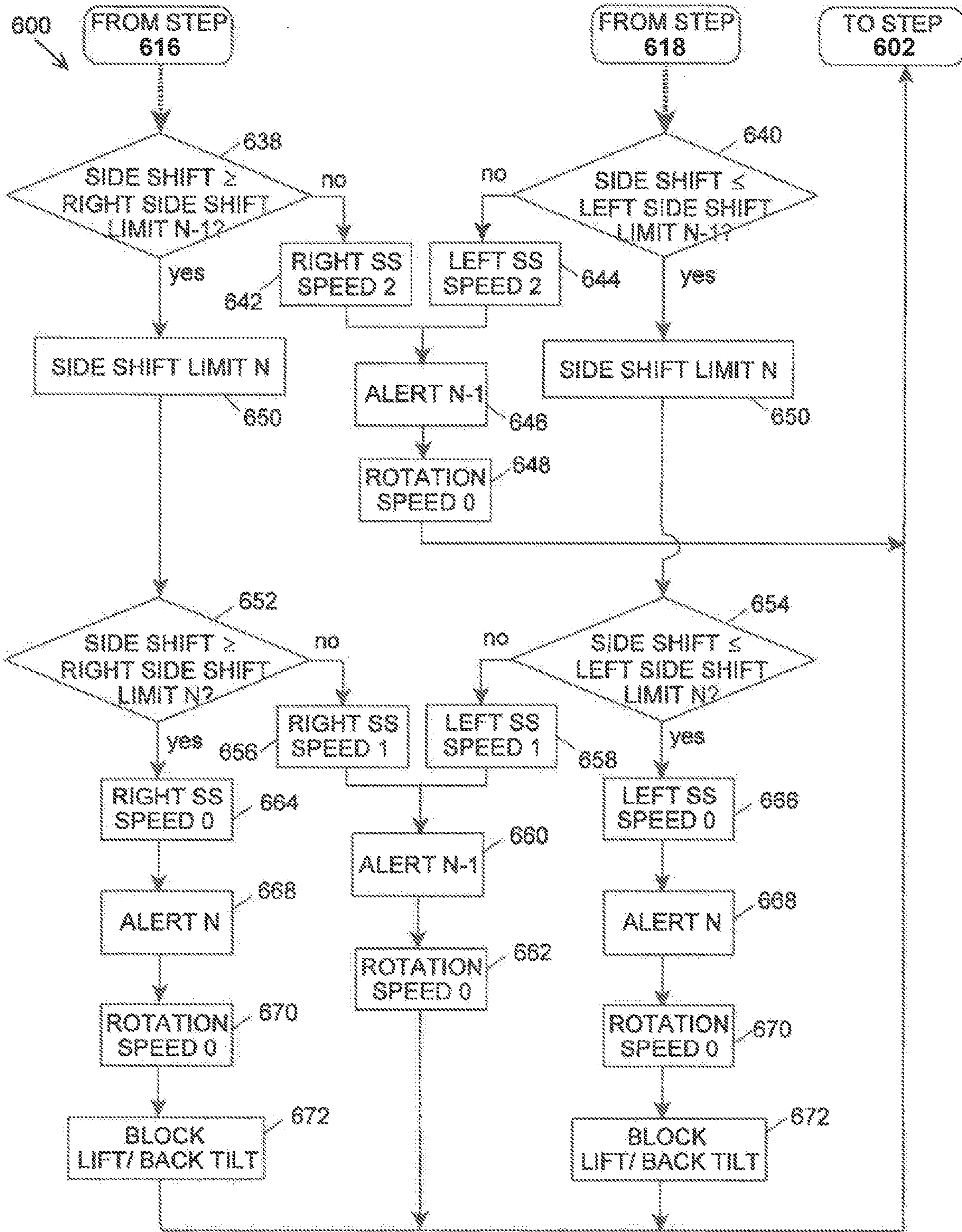

FIG. 6B Amended

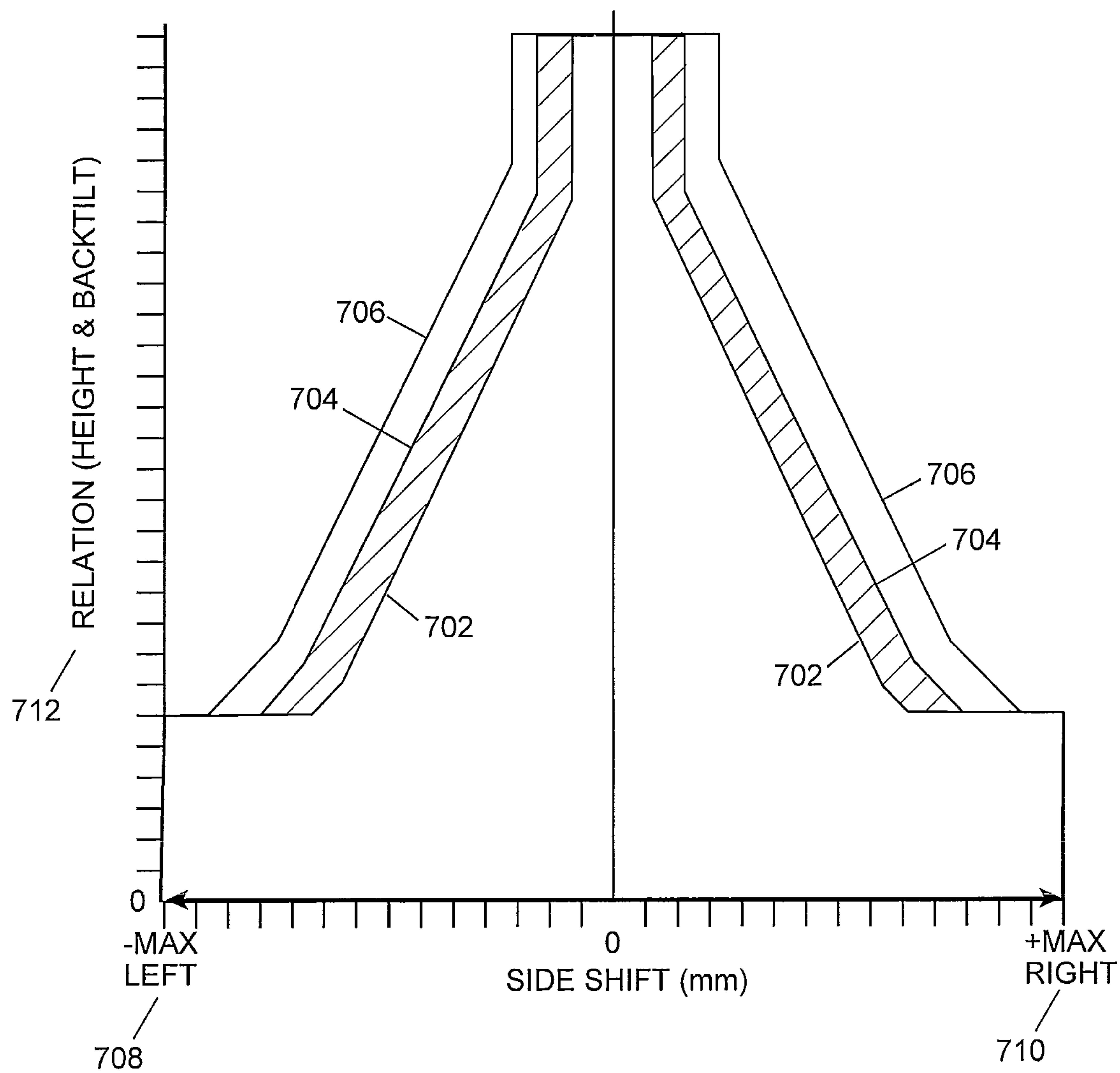

FIG. 7

SIDE-SHIFT LIMITER

Matter enclosed in heavy brackets [] appears in the original patent but forms no part of this reissue specification; matter printed in italics indicates the additions made by reissue; a claim printed with strikethrough indicates that the claim was canceled, disclaimed, or held invalid by a prior post-patent action or proceeding.

CROSS-REFERENCE TO RELATED APPLICATIONS

Not applicable.

BACKGROUND OF THE INVENTION

The present invention relates to a load engaging apparatus for use with material handling equipment and, more particularly, to controls for transversely movable load engaging members such as forks or clamp arms of a load engaging apparatus associated with material handling equipment.

Material handling equipment used for moving palletized or non-palletized loads from place to place, such as, for example, in a warehouse, typically includes forklift trucks or other types of material handling equipment equipped with load engaging members such as forks or clamp arms. For example, on a typical forklift truck load engaging forks are attached to a carriage which is in turn movably secured in a mast so as to enable the carriage and forks to travel vertically in the mast. Various types of attachments may also be mounted on the carriage or *include an* integrated [with the] carriage. For example, a sideshifter which moves the forks transversely in unison and/or a fork positioner which enables movement of the forks transversely toward and away from each other may be either attached to the carriage or integrated with the carriage structure. Likewise, a load clamp having load-engaging clamp arms similarly movable transversely *either* in unison [either] *or* toward [or] *and* away from each other may be attached to the carriage or integral to the carriage. Some attachments also include [amotor] *a motor* enabling rotation of the load engaging members and thereby the load about an axis substantially parallel to the longitudinal axis of the material handling equipment.

Load clamps rely on clamping forces applied to the sides of the load for securing the load for lifting and clamp arms may be engineered differently for handling rectangular or cylindrical loads. For example, paper roll clamps and drum-clamping forks may incorporate contours particularly useful for clamping cylindrical loads. On the other hand, "carton clamps" generally refers to clamps with clamp arms adapted to handle rectangular loads such as stacked cartons or household appliances. Carton clamp attachments typically include a pair of large blade-shaped clamp members each of which can be inserted between side-by-side stacks of cartons or appliances to bracket a load comprising one or more appliances or cartons. The clamp members on either side of the load are then drawn together, typically, using hydraulic cylinders to move the clamp members and to apply sufficient compressive force to the load to allow it to be lifted. To securely hold the load, the surfaces of the clamp members which contact the sides of the load are typically constructed of materials such as rubber faced aluminum providing a high coefficient of friction. Carton clamps are most frequently used in the warehousing, beverage, appliance, and electronics industries and may be specifically designed for particular types of loads. For example, carton clamps may be equipped

with contact pads that are sized for palletless handling of refrigerators, washers, and other large household appliances (also referred to as "white goods"). In various configurations, carton clamps may be used for handling multiple appliances at one time.

In addition to clamping a load in order to lift and move the load, clamps may be equipped with side-shifting capabilities whereby the clamped load may be repositioned from side-to-side with the clamping members moving transversely in one direction or the other in unison. Similarly, a fork positioner enabling transverse movement of load supporting forks to increase or decrease the distance between the forks may also include side-shifting enabling transverse movement of the forks in unison. When the longitudinal axis of the material handling vehicle is not perfectly aligned, transversely, with the center of a load, a stack or a rack space, side shifting can enable lateral alignment of the load engaging members, clamp arms or forks, with the load, stack or rack opening in which the load is to be engaged or deposited without further maneuvering of the vehicle. In addition, efficient utilization of space, notably when loading a transport vehicle, such as a trailer or railcar, commonly requires that loads be placed in close proximity to a wall or another obstacle. Side shifting allows loads that are narrower than the material handling vehicle to be placed close to a wall without first depositing the load and then pushing it, potentially, damaging it or the material handling vehicle. The side-shifting function may be actuated by one or more hydraulic cylinders separate from the clamping/fork positioning cylinder(s) ("external" side-shifting), or by the clamping/fork positioning cylinders themselves ("internal" side-shifting).

While side shifting is operationally advantageous, the off-center position of the load relative to the material handling vehicle adversely impacts the stability of the vehicle, particularly when the load is elevated. To compensate for the off-center weight of the load, a material handling vehicle may be "de-rated" and relegated to handling loads that are lighter than the nominal capacity load for the same vehicle when it is not equipped for side shifting. Conversely, a higher capacity, more expensive and less maneuverable material handling vehicle may be required to handle a load of a particular size or weight if the load can be side shifted.

What is desired, therefore, is a system and apparatus which optimizes the capability of a material handling vehicle equipped for side shifting.

BRIEF DESCRIPTION OF THE DRAWINGS

FIG. 1 is a perspective view of an exemplary forklift truck equipped with a load clamp.

FIG. 2 is a perspective view of a carton clamp attachment for a forklift truck arranged for limited internal side shifting.

FIG. 3 is a schematic of a side shifting clamp attachment and a side shift limiting system for a material handling vehicle.

FIG. 4 is a plan view of a forklift truck operating in a walled area.

FIG. 5 is a schematic representation of a forklift truck.

FIG. 6A is a first portion of a flow diagram for a method of side shift limiting.

FIG. 6B is a second portion of the flow diagram of FIG. 6A.

FIG. 7 is a graphic representation of side shift limits vs lift height and back tilt for a forklift truck.

DETAILED DESCRIPTION OF PREFERRED
EMBODIMENTS

In the following detailed description, numerous specific details are set forth in order to provide a thorough understanding of the preferred embodiments. However, those skilled in the art will understand that the present invention may be practiced without these specific details, that the present invention is not limited to the depicted embodiments, and that the present invention may be practiced in a variety of alternate embodiments. In other instances, well known methods, procedures, components, and systems have not been described in detail.

Although the preferred embodiments may be implemented in a wide variety of configurations involving different types of material handling equipment and different types of attachments, the following detailed description, where comparable elements are referred to with like reference numbers, discloses the preferred embodiments principally in the context of an exemplary forklift truck **100**, as illustrated in FIG. **1**, fitted with a carton clamp attachment **102**. As shown in FIGS. **1** and **2**, the carton clamp attachment **102** is configured for handling white goods such as the four washers **106**, **108**, **110**, **112** clamped between a first clamping member **116** (sometimes referred to as a clamp arm having a contact or clamp pad, which is shown engaging two of the washers **106**, **110**) and a second, oppositely oriented clamping member **118** which is hidden by the washers in the perspective view of FIG. **1**. The carton clamp attachment **102** may comprise a frame **104** that is attachable to a carriage movably secured in a mast assembly **114** mounted to the front of the forklift truck **100** or the attachment's frame may be movably securable in the forklift truck's mast and function as the carriage. Such carriage and mast assembly structures are well known and need not be described in further detail.

Referring also to FIG. **3**, the exemplary carton clamp attachment **102** includes a pair of large blade-shaped clamp members **116**, **118**, shown schematically in FIG. **3** and shown structurally in FIG. **2**, which can be positioned on opposing sides of a stack of appliances such as the washers **106**, **108**, **110**, **112** as shown in FIG. **1**. Preferably, the forklift is moved forward until the load engages the attachment's load face **120**, a portion of the attachment's structure, such as a portion of the frame **104** or the vertical face of load supporting forks, which is engageable with the load and which limits the load's displacement in the direction of the forklift. The clamp members on either side of the load (i.e. the washers **106**, **108**, **110**, **112**) are drawn together or moved apart by hydraulic cylinder assemblies **122**, **124** controlled by clamp-closing/opening hydraulic circuitry shown schematically in FIG. **3**. The hydraulic cylinder assemblies apply a compressive force to the load with sufficient pressure to enable the clamp members to frictionally secure the load for lifting.

Referring also to FIG. **4**, the carton clamp attachment **102** is preferably equipped with side-shifting capabilities whereby a datum **130**, for example, the center of the opening **133** between the load engaging members, for example, the clamp arms **116**, **118**, defining the lateral position of the load face **120** may be repositioned laterally with respect to the frame **104** of the attachment **102** and, since the frame of the attachment is fixed laterally with respect to the forklift truck, a lateral reference datum for the forklift truck such as the forklift truck's longitudinal center line **134**. The exemplary clamp **102** includes internal side-shifting capabilities where the same hydraulic cylinders **122**, **124** are arranged to move

in opposite directions for clamping and unclamping and to move in unison in the same direction for side shifting. However, shift-shifting may also be of an external type using separate hydraulic cylinders for, respectively, clamping and side-shifting movements.

A forklift truck commonly must be turned at a right angle to the aisle in which it is traveling to engage or deposit a load complicating alignment of the load engaging members with a load to be engaged or a location for depositing a load. If the longitudinal centerline **134** of the forklift is not aligned with the center of the load to be engaged or the place where the load is to be deposited, for example, on a stack, considerable maneuvering may be necessary to move the forklift laterally so that the load engaging members or the load is in the proper position. Side shifting promotes efficiency in forklift operation and reduces operator stress by enabling limited lateral repositioning of the load engaging members relative to the location where the load is to be engaged or deposited without maneuvering the forklift. This promotes more stable stacking and reduces the potential for damage. As illustrated in FIG. **4**, side-shifting is also advantageous when depositing a load which is narrower than the forklift proximate a wall or other obstacle, such as for example, when loading an intermodal container or a transport vehicle **402**, such as a highway trailer or a railcar. The ability to deposit a load close to a wall **404** is important for the full and efficient utilization of the available volume of the walled area and sideshifting avoids the need to deposit the load and then push it toward the wall which can result in damage to the load and/or the forklift truck.

While side shifting is advantageous, the lateral displacement of the load relative to the forklift adversely impacts the stability of the forklift particularly when the load is elevated. Referring to FIG. **5**, for visualizing the effect of side shifting on the stability of a forklift truck, a counterbalanced forklift may be represented as a pyramid **502** with a triangular base **504** defined by a first axis **506**, A-B, extending between the respective areas of contact of the forklift's front or load wheels **508**, **510** and second **512** and third **514** axes, A-C and B-C, extending from the center pivot of the rear axle **516** to respective areas of contact of the load wheels. Gravity acts vertically at the combined center of mass **520**, which is concentrated at the apex of the pyramid and represents the center of mass **522** of the unladen forklift **[522]** combined with the center of mass **524** of the load **[524]**, if any. On the other hand, dynamic forces produced by changes in speed and/or direction of the forklift and the load act horizontally at the combined center of mass to urge movement of the center of mass in the direction of at least one of the axes defining the base of the pyramid, A-B, A-C, B-C. For example, braking while moving forward urges the combined center of mass toward axis A-B and centrifugal force produced by turning urges the combined center of mass laterally toward one of the bounding axes A-C or B-C. The pyramid (the forklift) will tip if the combined center of mass of the forklift moves outside of the triangular base **504**.

If a capacity load is carried low and centered, the combined center of mass **520** will be located closer to the axis A-B than the center of mass **522** of the unladen forklift **[522]** and substantially distal of axes A-C and B-C. While resistance to tipping forward when braking is lower, the forklift has substantial reserve resistance to tipping to the side because the low position of the combined center of mass **520** means the horizontal forces are applied to a relatively short moment arm and must displace the combined center of mass a substantial distance before reaching either axis A-C or B-C. But when the load (center of mass **524**) is raised toward

point 524', the combined center of mass 520' rises with the load to a location more distant from the three axes defining the base of the pyramid, increasing the length of the lever arm on which the horizontal forces act and lowering the resistance of the forklift to tipping in all directions. And when the center of mass of the load is moved laterally away from the longitudinal centerline 134 of the forklift toward point 524", for example, by side shifting, the combined center of mass moves in the direction that the load was shifted toward point 520" and closer to one of the axes, A-C or B-C, reducing the resistance of the forklift to tipping to the side. Furthermore, tilting the mast back shifts the load toward point 524'" and the combined center of mass rearward toward point [520m] 520'" and the apex of the triangular base and even closer to the axes A-C and B-C. Tilting is commonly limited if a forklift is equipped with a mast capable of lifting to substantial heights and may also be restricted if the forklift is equipped for side shifting.

Forklift trucks equipped for side shifting are commonly "derated," that is, the maximum weight of the load that is to be handled with the side shift-capable forklift truck is less than the rated load of the same forklift when not equipped for side-shifting. Conversely, a larger, less maneuverable and more expensive forklift may be required to handle a particular load when the forklift is equipped for side-shifting. However, the inventors herein have realized that the greatest lateral movement of the load is often desired when the load is at a relatively low lift height, for example, to place a load proximate a wall of a transport vehicle, and when the load is lifted higher, more limited lateral shifting of the load will often suffice to permit centering the load engaging members with respect to a load or aligning a load with a stack or a rack opening. In addition, restricting side shifting speed as the lift height, back tilt and/or lateral displacement of the load increases reduces the dynamic forces resulting from acceleration and deceleration of the load. The inventors have concluded that the capacity of a forklift truck can be optimized by limiting the lateral displacement and speed of the load when it is lifted to greater heights and/or tilted rearward while allowing maximum side-shifting displacement and speed at lower lift heights.

Referring to FIG. 3, the exemplary forklift 100 is equipped with a system 302 that limits the lateral speed and displacement of the side shifting attachment 102 according to the lift height and, preferably, the back tilt of the mast and announces one or more alerts to the forklift's operator when lateral displacement of the attachment is approaching or has reached one or more limits. The pair of hydraulic cylinder assemblies 122, 124 are arranged to move the load engaging members, clamp arms 116, 118, in directions transverse to the longitudinal axis 134 of the forklift. The exemplary attachment 102 is arranged for internal side shifting with the hydraulic cylinder assemblies 122, 124 connectable to a source of pressurized fluid, pump 304, in ways that cause the cylinders to either extend or retract in opposing directions to clamp or unclamp a load between the clamp arms 116, 118 or to extend or retract in the same direction to move a load face datum defining the lateral position of the attachment's load face, for example, the lateral centerline of the load face 130 defined by the clamp arms, relative to the lateral center 132 of the attachment's frame 104 and thereby relative to a datum establishing the lateral position of the forklift 100, for example, the longitudinal centerline 134 of the forklift.

Typically, the pump 304 is driven by a motor or engine (not shown) of the material handling equipment, for example, the exemplary forklift truck 100, and draws fluid from a reservoir 306 and discharges the fluid to a supply

conduit 308. When the plural control valves 310, 312, 314, [712] 713 and 716 are centered (as pictured) and blocking the passage of fluid toward the system's actuators, i.e. the hydraulic cylinder assemblies 122, 124 and the motor 315, passages in each of the control valves and an open center conduit 316 connect the supply conduit 308 to the reservoir 306. If the pressure in the supply conduit 308 exceeds a system relief pressure, a system relief valve 318 will permit fluid to flow from the supply conduit to the reservoir.

The exemplary system 302 includes a clamp/unclamp control valve 312 or, if the forklift truck is equipped with a fork positioner attachment, a fork position control valve, which includes a valve spool that is shiftable to the left from the illustrated center position blocking flow to a second position enabling pressurized fluid to flow from the supply conduit 308 and open center conduit 316 through conduits 320 and 352 to the rod ends 322, 324 of the hydraulic cylinder assemblies 122, 124. Pressure in the rod ends 322, 324 urges the cylinders to retract moving the clamp arms 116, 118 toward each other to clamp a load. Pressure in conduit 320 unseats a pair of pilot operated check valves 326, 328 allowing fluid to flow out of the piston ends 330, 332 of the hydraulic cylinders through conduits 334, 336. The fluid expelled from the piston ends of the hydraulic cylinders 122, 124 flows through a flow divider/combiner valve 338 which maintains a substantially equal flow from the piston ends of the respective cylinders so that the cylinders retract at substantially the same rate. The fluid from the piston ends 330, 332 of the hydraulic cylinders 122, 124 flows from the flow divider/combiner valve 338 to the reservoir 306 through a conduit 340, a passage in the clamp/unclamp control valve 312 and the open center conduit 316. Conversely, shifting the clamp/unclamp control valve 312 to the right from the center position directs pressurized fluid through conduit 340 to the flow divider/combiner valve 338 and then through conduits 334, 336 and check valves 326, 328 to the piston ends 330, 332 of the hydraulic cylinders 122, 124. Pressure in the piston ends of the hydraulic cylinders and opening of the clamp arms 116, 118 and forces fluid from the rod ends 322, 324 of the hydraulic cylinders back to the reservoir 306 via conduits 320, 352 and the pilot operated check valve 350 which, due to pressure in conduit 340, is open.

The side shift control valve 310 is also a three position valve with a center position (as illustrated) blocking flow toward the hydraulic cylinders 122, 124. When the valve is moved to the left from the illustrated centered position, fluid is directed from the open center conduit 316 to conduit 342 and a right secondary side shift control valve 346 which is normally open permitting flow into conduit 343 to the piston end 332 of the right hand hydraulic cylinder 124. The pressure in the piston end of the right-hand hydraulic cylinder 124 urges the cylinder to extend and move the right hand clamp arm 116 to the right. Fluid is forced out of the rod end 324 of the right hand cylinder 124 but the check valve 350 blocks flow to the reservoir 306 forcing the fluid to flow to the rod end 322 of the left hand hydraulic cylinder assembly 122 through conduit 352. Fluid is expelled from the piston end of the left hand hydraulic cylinder assembly 122 through conduit 359 and, at least one of the check valve 354 and the normally open, left secondary side shift control valve 348. Fluid returns to the reservoir 306 through the side shift control valve 310 and the left hand clamp arm 118 moves to the right in unison with the right hand clamp arm 116.

Conversely, moving the sideshift control valve **310** to the right from the center position directs fluid from the pump **304** into conduit **358**. The fluid flows through the normally open, left secondary side shift valve **348** and into the piston end **330** of the left hand hydraulic cylinder assembly **122** through conduit **359**. The left hand hydraulic cylinder is urged to extend and move the left hand clamp arm **118** left forcing fluid from the rod end **322** of the left hand hydraulic cylinder **122** through conduit **352** to the rod end **324** of the right hand hydraulic cylinder **124**. Fluid is expelled from the piston end of the right hand hydraulic cylinder assembly **124** through conduit **343** and, at least one of the check valve **356** and the normally open, [left] right secondary side shift control valve **346**. Fluid returns to the reservoir **306** through the side shift control valve **310** and the right hand clamp arm **116** moves to the left in unison with the left hand clamp arm **118**.

In addition, the exemplary attachment **102** includes a hydraulic motor **315** arranged to rotate the attachment's load face about an axis substantially parallel to the longitudinal centerline **134** of the forklift. The hydraulic motor **315** is controlled by a rotation control valve **314** similar to the side shift control valve **310** and the clamp/unclamp valve **312**. Shifting the rotation control valve **314** in a first direction directs oil into conduit **362** and through a normally open, secondary rotation control valve **364**. Pressure in conduit **363** unseats the pilot operated check valve **317** permitting fluid to flow through the check valve **319**, the motor **315** and back to the reservoir through conduit **365** causing the motor to rotate the attachment's load face in a first direction. Shifting the rotation control valve **314** in the opposite direction from the center position causes the motor **315** to rotate the attachment's load face in the direction opposite of the first direction.

The exemplary attachment **102** further comprises a side shift sensor (indicated generally as) **370** which may comprise multiple sensors as described hereafter, a lift height sensor **372** and, preferably, a back tilt sensor **374**. The lift height sensor **372** is preferably affixed to the frame **104** of the attachment **102** and enables determination of a distance between a height datum for the attachment, for example, the location of the lift height sensor, and the surface supporting the material handling vehicle. Although the lift height may be measured directly, it may also be computed by sensing a distance to a reference datum on the material handling vehicle, for example the base of the mast **114**, which has a known or determinable distance from the ground. By way of examples only, the lift height sensor may comprise a laser range finder, a cable actuated encoder, an optical sensor arranged to detect targets affixed to the material handling vehicle or an accelerometer arranged to determine displacement from a datum by dead reckoning.

The side shift sensor **370**, which may comprise plural sensors **370A** and **370B**, is preferably affixed to a portion of the attachment that does not move laterally with respect to the material handling vehicle, such as the frame **104** or the shells of the hydraulic cylinder assemblies **122**, **124**, and enables determination of a distance between a lateral load face datum, such as the lateral center **130** of the load face **133** as defined by the load engaging members, and a lateral datum of the material handling vehicle, such as the vehicle's longitudinal center line **134**. External side shifting attachments comprise an actuator, typically a hydraulic cylinder assembly, which is dedicated to the side shift function, enabling the lateral displacement to be determined with a single side shift sensor arranged to detect the displacement of the actuator or another part of the attachment displaced by

the actuator. On the other hand, internal side shifting attachments, such as the exemplary attachment **102**, typically utilize plural actuators to provide for coordinated movement of the clamp arms or other load engaging members and the location of the load face lateral datum is, preferably, determined from respective measurements to each load engaging member **116**, **188** or a structural element movable with the load engaging members by one or more side shift sensors, such as plural side shift sensors **370A**, **370B**. The plural side shift sensors are preferably attached to points fixed relative to the material handling vehicle, for examples the shells of the clamping/side shift hydraulic cylinder(s) as shown in FIG. **2** or the attachment frame **104**. By way of example only, the sideshift sensor(s) **370** might comprise laser range finders, cable actuated encoders, linear transducers, an accelerometer, optical sensors arranged to detect and count or decode targets on movable portions of the attachment or the actuators as disclosed in U.S. Patent Publication No: US 2013/0277584 or one or more limit switches operable by lateral displacement of a portion of the attachment.

The exemplary attachment **102** also preferably, but not necessarily, includes a sensor **374** to detect the rearward tilt of the material handling vehicle's mast **114**. The angle of the mast and load face of a forklift is typically changed by a pair of hydraulic tilt cylinder assemblies **720** connecting the forklift's frame and mast **114**. Mast tilt may be sensed, for example, by a linear transducer attached to the mast or one of the hydraulic tilt cylinder assemblies or, preferably, by an inclinometer or triaxial accelerometer affixed to the attachment.

Referring also to FIGS. **6A** and **6B**, an exemplary side shift limiting method **600** is executed by a controller **380**, shown in FIG. **3**, and, preferably, affixed to the attachment **102**. The controller operates according to instructions stored in a memory to periodically read the outputs of the side shift sensor(s) *at step 602*, the lift height sensor *at step 604* and, optionally, the back tilt sensor *at step 606* and to output signals to activate transducers providing one or more alerts to the operator of the material handling vehicle and/or limit the speed and/or displacement of the attachment if the sensed lateral displacement of a load face lateral datum exceeds one or more side shift limits corresponding to the sensed lift height or, preferably, the sensed lift height and back tilt. Referring also to FIG. **7**, one or more side shift limits, for example side shift limits **702**, **704**, **706**, may be stored in a memory of the controller **380** for each of plural lift heights, preferably at one or more back tilt angles, or for each of plural values of a relationship combining back tilt and lift height. On the other hand, the controller may calculate one or more side shift limits for the sensed lift height or, alternatively, the sensed lift height and back tilt. As illustrated in FIG. **7**, the maximum side shift displacement **708**, **710**, on either side of the fork lift center line datum **134** is preferably permitted only at lower lift heights or when a relationship of lift height and back tilt **712** is relatively low. By way of example only, "lower lift heights" might be lift heights lower than the mast's freelif height, i.e. the lift height at which the overall height of the mast begins increasing, or a lift height enabling a second load to be deposited on a load having the height of a rated load for the material handling vehicle. At higher lift heights, preferably combined with back tilt, side shifting displacement and speed may be restricted to limit or reduce the effects of lateral acceleration of an off-center load on the stability of the material handling vehicle. For example, unrestricted side shift speed may be permitted within a first side shift limit **702** and side shift displacement and attachment rotation, if

applicable, and, optionally, hoisting and/or back tilting may be blocked at a maximum side shift limit **706** appropriate for a sensed [a] lift height and, preferably, a lift height and back tilt. At one or more other side shift limits between a first side shift limit **702** and a second side shift limit **706**, for example side shift limit **704**, other action may be taken such as issuing various alerts to the operator and/or reducing the side shift speed to reduce dynamic forces produced by acceleration/deceleration of the load and/or, if the attachment includes a rotator, blocking or limiting rotator speed. For example, the side shifting speed may be restricted to vary proportionally or non-proportionally with displacement over some portion of the side shift displacement. Maximum side shift displacement may be permitted to a specified lift height, and/or lift height and back tilt angle, and side shift displacement may be restricted to a single value at greater lift heights or, as illustrated, there may be a range of lift heights or lift height and back tilt angles where the permitted side shift displacement is changing according to a relationship with the lift height or, preferably, a relationship combining the lift height and the back tilt. Typically, the side shift limits are symmetrical about the longitudinal center line of the forklift but for certain loads the limits might differ on respective sides of the centerline.

With reference to FIG. 6A, the controller **380** looks up, calculates or otherwise determines a first side shift limit at step **608**, a first limiting value of the lateral displacement of a load face datum, for example the center **130** of the load face [130] **120**, relative to a lateral datum for the material handling vehicle, for example the longitudinal centerline **134**. For example the first side shift limit may be the value of the side shift limit **702**, corresponding to the [sensed] lift height sensed at step **604** and preferably the [sensed] lift height sensed at step **604** and back tilt sensed at step **606** measured by the respective sensors. At step **610**, the controller compares the first right side shift limit to the sensed side shift displacement. If the [sensed] side shift displacement sensed at step **602** is not equal to or greater than the value of a first right hand side shift limit, the controller determines if the side shift displacement is less than a first left side shift limit at step **612**. In the example illustrated in FIG. 7 the magnitude of the right and left side shift limits are the same for any lift height and back tilt but a position to the right of the lateral center **132** of the attachment's frame, and thereby to the right of the centerline **134** of the forklift truck **100** (right side shift), may have a positive value while a position to the left of the lateral center of the attachment (left side shift) may have a negative value. The lateral displacement of the load face datum **130** can be determined by, for example, subtracting from the lateral position of the right clamp arm **116** or adding to the lateral position of the left clamp arm **118** one half of the sum of the absolute values of the lateral positions of the respective clamp arms, that is, one half of the distance **133** between the clamp arms [133] **116**, **118**. If the side shift displacement does not exceed either the first right or first left side shift limit, the controller reads side shift displacement sensed at step **602**, the lift height sensed at step **604** and, preferably, the back tilt sensed at step **606** again.

If the sensed side shift displacement equals or exceeds one of the first right or the first left side shift [limit] limits at steps **610**, **612**, the controller determines a second side shift limit at step **614** for the respective side shift direction. The second side shift limit, for example, side shift limit **704**, typically includes greater lateral displacement than the first side shift limit. The controller **380** compares the sensed side shift displacement to the appropriate second right [616] or

left side shift [limit] limits at steps **616** and **618**. If the sensed side shift exceeds a first side shift limit but does not equal or exceed the second right side shift limit at step **616** or the second left side shift limit at step **618**, as appropriate, the controller may signal at steps **620**, **622** the appropriate one of the right secondary side shift valve **346** or the left secondary side shift valve **348** to restrict the fluid flowing in the appropriate direction to the side shift hydraulic cylinder (s) thereby [the] limiting the side shifting speed in the direction that would tend to reduce the material handling vehicle's resistance to tipping. Preferably, the right **346** and left **348** secondary side shift valves and the secondary rotation valve **364** are proportional flow valves arranged to meter the respective flows in response to differing or varying signals, such as pulse width modulated signals, from the controller. Also preferably, the controller **380** includes instructions to vary the signal to the secondary side shift valves and the secondary rotation valve to variably restrict the respective flows to control acceleration as well as the speed of the hydraulic actuators limiting forces produced by movement of the load.

If the side shift displacement exceeds the first side shift limit but does not exceed a second side shift limit, the controller **380** may signal an alert controller **386** to issue an operator alert at step **624**. The exemplary system **302** includes a first transducer **388** arranged to visually alert the operator of the material handling vehicle that the side shift displacement has reached or is proximate a limit, and a second transducer **390** to audibly alert the operator in response to signals output by an alert controller **386**. Preferably, the controller **380** is located on the attachment and is communicatively connected to the alert controller **386** by a first radio frequency transceiver **382** and a second radio transceiver **384** associated with the alert controller which is preferably located on the material handling vehicle. The first transducer **388** may comprise, for example, an array of lights of different colors, a light which flashes at plural frequencies or a display for a text message to indicate that side shifting has reached or is proximate a side shift limit. The audible operator alerting transducer **390** might, by way of example, comprise a tonal device which annunciates a tone of varying frequency, amplitude or intermittence as the side shift increases or the audible alert transducer may comprise a speech synthesizer that emits recorded or synthesized messages, for example advising the operator when the appropriate side shift limit is reached or is approaching, that further side shifting will be slowed or blocked and/or that the attachment should be centered, if possible. If the side shift displacement exceeds either of the first side shift limits but not the second side shift limit, the controller **380** reads the lift height at step **604**, back tilt at step **606** and side shift at step **602** [sensors] again.

Referring also to FIG. 6B, if, however, the side shift displacement exceeds the first and the second side shift limit, the controller determines a next side shift limit and repeats the process until the sensed side shift displacement no longer exceeds a side shift limit. For example, in a system with n side shift limits, if the sensed side shift exceeds the first $n-2$ side shift limits but does not exceed the right $n-1$ side shift limit at step **638** or the left $n-1$ side shift limit at step **640**, for example, the controller **380** may signal the appropriate secondary side shift valve to further reduce the side shift speed at steps **642**, **644** and direct the alert controller **386** to issue a different operator alert at step **646**. If the attachment includes a rotator, the controller may signal the secondary rotation control valve **364** to restrict or prevent rotation at

step 648 to prevent or lessen dynamic forces accompanying a change in speed or position of the load's center of mass.

If the side shift displacement exceeds either the right or the left *n*-1 (next to last) side shift limit, the controller **380** determines *at step 650* the maximum side shift limit (limit *n*), for example limit **706**, corresponding to the sensed lift height and, preferably, back tilt, **[650]**. The controller compares the sensed side shift displacement to the appropriate right **[652** or left **654]** maximum side shift limit *at step 652* and the appropriate left maximum side shift limit *at step 654*. If the sensed side shift displacement does not equal or exceed one of the maximum side shift limits, the controller **380** may further restrict the appropriate right **[656** or left **658]** side shift speed *at step 656* and the appropriate left side shift speed *at step 658*, issue a new operator alert or continue the issuance of an earlier operator alert *at step 660* and block or continue to block rotation *at step 662*.

If, however, the side shift displacement equals or exceeds one of the right **[652]** or left **[654]** maximum (*n*) side shift limits at the sensed lift height and, preferably back tilt, the controller preferably signals the appropriate secondary side shift valve **346, 348** to block further side shift displacement in the direction of the maximum limit *at steps 664[,] and 666, respectively*. In addition, the controller **380** may signal the alert controller **386** to issue another operator alert *at step 668*, block rotation *at step 670* and block lifting and/or back tilting *at step 672*. The check valves **354, 356** permit fluid to flow from the respective piston ends **330, 332** of the hydraulic cylinders **122, 124** enabling centering of the attachment even if the right secondary side valve **346** or the left secondary side shift valve **348** is shifted to block a flow of fluid which would increase the side shifting. In any event, the controller **380** continues sampling the output of the side shift, lift height and back tilt transducers and comparing the sensed side shift displacement to one or more side shift limits for the sensed lift height and preferably the sensed lift height and sensed back tilt.

Alternatively, the controller **380** may transmit signals to the alert controller **386** to control the side shifting and rotation of the attachment and, optionally, the lifting and/or tilting of the material handling vehicle's mast. If the material handling vehicle is equipped with a remotely controllable side shift valve, such as side shift valve **310**, the side shift displacement and speed may be controlled by operation of the side shift valve without intervention of secondary side shift valves, such as secondary side shift valves **346, 348**. Instructions from the controller **380** and, preferably, relayed by the alert controller **386** to a vehicle controller **[710]** *711* which controls the operation of a remotely operable side shift valve **310** may cause the vehicle controller to manipulate the remotely operable side shift valve to change the side shift speed and maximum lateral displacement or to cause the attachment to be displaced toward the center of the frame as the lift height and/or back tilt increases to keep the side shift within a limit. On the other hand, the alert controller could be arranged to transmit a signal directly to a remotely operable valve, such as tilt valve **716**, to cause the valve to control the operation of associated transducers, such as tilt cylinders **720**.

Optionally, functions such as lifting and tilting may be controlled with secondary valves, such as the secondary lifting control valve **714** and the secondary tilting control valve **722**. If the operator of the material handling vehicle attempts to lift a side shifted load to a height that would exceed an allowable lift height for the sensed lateral position of the load, a signal from the controller **380** or the alert controller **386** can shift a secondary lifting valve **714** to

block the flow of hydraulic fluid from the material handling vehicle's hoist valve **[712]** *713* preventing further lifting. Likewise, if the operator of the material handling vehicle attempts to tilt the vehicle's mast at a lift height that would exceed an allowable lift height and back tilt for the sensed lateral position of the load, a signal from the controller **380** or the alert controller **386** can shift a secondary tilting control valve **722** to limit or block the flow of hydraulic fluid from the material handling vehicle's tilt control valve **716** limiting the speed or preventing further back tilting.

The side shift limiting attachment alerts the operator if lateral displacement of the load face is approaching a limit for a lift height and, preferably, back tilt and blocks or slows further side shifting and/or rotation of the attachment when a side shift limit is reached for a specific lift height and back tilt.

The detailed description, above, sets forth numerous specific details to provide a thorough understanding of the present invention. However, those skilled in the art will appreciate that the present invention may be practiced without these specific details. In other instances, well known methods, procedures, components, and circuitry have not been described in detail to avoid obscuring the present invention.

All the references cited herein are incorporated by reference.

The terms and expressions that have been employed in the foregoing specification are used as terms of description and not of limitation, and there is no intention, in the use of such terms and expressions, of excluding equivalents of the features shown and described or portions thereof, it being recognized that the scope of the invention is defined and limited only by the claims that follow.

We claim:

1. A system for limiting a lateral position of a load face **[for]** and associated with a material handling vehicle, the system comprising:

- (a) a lateral position sensor arranged to output a lateral position datum **[quantifying]** representative of a distance between a material handling vehicle **[lateral datum]** longitudinal centerline and a load face lateral datum;
- (b) a height sensor arranged to output a height datum **[quantifying]** representative of a height of **[a vertical]** the load face **[datum]** relative to a surface supporting said material handling vehicle; and
- (c) a controller arranged to receive said lateral position datum and said height datum and to output a first side shift control signal when said lateral position datum corresponds to a first side shift limit **[for]** at said height datum and output a second side shift control signal when said lateral position datum corresponds to a second side shift limit at said height datum, the first side shift limit having a magnitude greater than that of the second side shift limit relative to the longitudinal centerline, and each of the first and second side shift control signals restricting the lateral motion of the load face.

[2. The system for limiting a lateral position of a load face for a material handling vehicle of claim **1** further comprising a tilt sensor arranged to output a tilt datum quantifying an angle of said load face, said controller arranged to receive said tilt datum and output said side shift control signal when said lateral position datum corresponds to a side shift limit for said height datum and said tilt datum.]

3. The system **[for limiting a lateral position of a load face for a material handling vehicle]** of claim **1** further compris-

13

ing a side shift indicator responsive to *at least one of* said *first* side shift control signal and *said second side shift control signal* to announce that said load face lateral datum corresponds to *the respectively associated* said side shift limit.

4. The system [for limiting a lateral position of a load face for a material handling vehicle] of claim 3 wherein [announcement that said load face lateral datum corresponds to said side shift limit] *the side shift indicator* comprises an optical signal.

5. The system [for limiting a lateral position of a load face for a material handling vehicle] of claim 3 wherein [announcement that said load face lateral datum corresponds to said side shift limit] *the side shift indicator* comprises an audible signal.

6. The system [for limiting a lateral position of a load face for a material handling vehicle] of claim 3 further comprising a *second* side shift indicator [responsive to a second side shift control signal output by said controller] to announce that said load face lateral datum is proximate *at least one of* said *first* side shift limit and *said second side shift limit*.

7. The system [for limiting a lateral position of a load face for a material handling vehicle] of claim 6 wherein [announcement that said load face lateral datum corresponds to said side shift limit] *said side shift indicator* comprises a first optical signal and said [announcement that said load face lateral datum is proximate said side shift limit] *second side shift indicator* comprises a second optical signal.

8. The system [for limiting a lateral position of a load face for a material handling vehicle] of claim 6 wherein [announcement that said load face lateral datum corresponds to said side shift limit] *said side shift indicator* comprises a first audible signal and said [announcement that said load face lateral datum is proximate said side shift limit] *second side shift indicator* comprises a second audible signal.

9. The system [for limiting a lateral position of a load face for a material handling vehicle] of claim 1 [further comprising a side shift control responsive to] *where* said *first* side shift control signal [to restrict] *restricts* a speed of lateral movement of said load face when said lateral position datum corresponds to said *first* side shift limit.

10. The system [for limiting a lateral position of a load face for a material handling vehicle] of claim [1] *wherein* said [side shift control responsive to said] *second* side shift control signal blocks lateral movement of said load face [when said lateral position datum corresponds to said side shift limit].

11. The system [for limiting a lateral position of a load face for a material handling vehicle] of claim 9 further comprising a side shift indicator responsive to said *first* side shift control signal to announce that said load face lateral datum corresponds to said *first* side shift limit.

12. The system [for limiting a lateral position of a load face for a material handling vehicle] of claim 11 wherein [announcement that said load face lateral datum corresponds to said side shift limit] *said side shift indicator* comprises an optical signal.

13. The system [for limiting a lateral position of a load face for a material handling vehicle] of claim 11 wherein [announcement that said load face lateral datum corresponds to said side shift limit] *said side shift indicator* comprises an audible signal.

14. The system [for limiting a lateral position of a load face for a material handling vehicle] of claim 11 further comprising a *second* side shift indicator responsive to [a] *the*

14

second side shift control signal [output by said controller] to announce that said load face lateral datum is proximate said *second* side shift limit.

15. The system [for limiting a lateral position of a load face for a material handling vehicle] of claim 14 wherein [announcement that said load face lateral datum corresponds to said side shift limit] *said side shift indicator* comprises a first optical signal and said [announcement that said load face lateral datum is proximate said side shift limit] *second side shift indicator* comprises a second optical signal.

16. The system [for limiting a lateral position of a load face for a material handling vehicle] of claim 14 wherein [announcement that said load face lateral datum corresponds to said side shift limit] *said side shift indicator* comprises a first audible signal and said [announcement that said load face lateral datum is proximate said side shift limit] *second side shift indicator* comprises a second audible signal.

17. The system [for limiting a lateral position of a load face for a material handling vehicle] of claim 9 [wherein said side shift control permits] *permitting* lateral movement of said load face to decrease a distance between said material handling vehicle [lateral datum] *longitudinal centerline* and said load face lateral datum when said lateral position datum corresponds to *at least one of* said *first* side shift limit and *said second side shift limit*.

18. The system [for limiting a lateral position of a load face for a material handling vehicle] of claim 9 further comprising a rotator control responsive [to said side shift control signal] to interrupt rotation of said load face when said lateral position datum corresponds to *at least one of* said *first* side shift limit and *said second side shift limit*.

[19. The system for limiting a lateral position of a load face for a material handling vehicle of claim 1 further comprising a lifting control responsive to said side shift control signal to prevent increasing said height datum when said lateral position datum corresponds to said side shift limit.]

[20. The system for limiting a lateral position of a load face for a material handling vehicle of claim 2 further comprising a tilting control responsive to said side shift control signal to prevent an increase in said tilt datum when said lateral position datum corresponds to said side shift limit.]

21. A load handling attachment for a material handling vehicle, said load handling attachment comprising;

(a) a load face defined by a load engaging member and movable laterally and vertically relative to said material handling vehicle;

(b) a lateral position sensor arranged to output a lateral position datum [quantifying] *representative of* a distance to a lateral load face datum *from a reference position*;

(c) a height sensor arranged to output a height datum [quantifying] *representative of* a distance between a load face height datum and a surface supporting said material handling vehicle; and

(d) a controller arranged to receive said lateral position datum and said height datum and operable [according to a stored instruction] to output a *first* side shift control signal when said lateral position datum exceeds a *first* side shift limit [for] *at* said height datum and *selectively output a second side shift control signal when said lateral position datum exceeds a second side shift limit at said height datum, the second side shift limit different in magnitude from that of the first side shift limit, each of the first and second side shift control signals restricting the lateral motion of the load face.*

15

22. The load handling attachment of claim 21 further comprising a side shift control device to limit a speed of lateral displacement of said [lateral] load face [datum] in response to said *first* side shift control signal.

23. The load handling attachment of claim 22 wherein said side shift control device prevents a lateral displacement of said [lateral] load face [datum] in response to said *second* side shift control signal.

24. The load handling attachment of claim 23 wherein said side shift control device permits decreasing said lateral displacement of said [lateral] load face [datum] when increasing said lateral displacement is blocked.

25. The load handling attachment of claim 21 further comprising a tilt sensor arranged to quantify an angular orientation of said load face, said controller arranged and operable [according to a stored instruction] to output [said] a respective one of the *first* side shift control signal and the *second side shift control signal* when said lateral position datum exceeds a side shift limit for said height datum at a predetermined angular orientation.

26. The load handling attachment of claim 21 further comprising:

- (a) an actuator arranged to selectively rotate said load face; and
- (b) a rotation control arranged to limit a speed of rotation of said load face in response to at least one of said *first* side shift control signal [and a rotation control signal from said controller] and said *second side shift control signal*.

[27. The load handling attachment of claim 21 further comprising an audible side shift indicator responsive to said side shift control signal to audibly announce that said lateral displacement of said load face is proximate a side shift limit.]

[28. The load handling attachment of claim 21 further comprising a visual side shift indicator responsive to said side shift control signal to visually signal that said lateral displacement of said load face is proximate a side shift limit.]

[29. The load handling attachment of claim 21 further comprising a lifting control device responsive to said side shift control signal to prevent an increase in said height datum when said lateral position datum exceeds a side shift limit for said height datum.]

[30. The load handling attachment of claim 25 further comprising a tilting control device responsive to said side shift control signal to prevent a change in said angular orientation of said load face when said lateral position datum exceeds a side shift limit.]

31. A method for limiting a lateral position of a load face for a material handling vehicle, the method comprising the steps of:

- (a) quantifying a distance between a material handling vehicle lateral datum and a load face lateral datum;

16

- (b) quantifying a height of a vertical load face datum relative to a surface supporting said material handling vehicle; and

- (c) limiting [a] the speed [of] at which lateral displacement of said load face [datum when] occurs whenever said distance between said material handling vehicle lateral datum and said load face lateral datum [corresponds to] exceeds a limit at said height datum.

[32. The method of limiting the lateral position of a load face for a material handling vehicle of claim 31 further comprising the steps of:

- (a) quantifying an angle of said load face; and
- (b) further limiting said speed of lateral displacement when said distance between said material handling vehicle lateral datum and said load face lateral datum corresponds to a limit at said height datum and said angle of said load face.]

33. The method [of limiting the lateral position of a load face for a material handling vehicle] of claim 31 further comprising the step of displaying an optical signal when said distance between said material handling vehicle lateral datum and said load face lateral datum is proximate said limit.

34. The method [of limiting the lateral position of a load face for a material handling vehicle] of claim 31 further comprising the step of annunciating an audible signal [when said] when said distance between said material handling vehicle lateral datum and said load face lateral datum is proximate said limit.

35. The method [of limiting the lateral position of a load face for a material handling vehicle] of claim 31 further comprising the step of preventing an increase in said height of said vertical load face datum when said distance between said material handling vehicle lateral datum and said load face lateral datum corresponds to said limit.

36. The method [of limiting the lateral position of a load face for a material handling vehicle] of claim 31 further comprising the steps of:

- (a) quantifying an angle of said load face; and
- (b) preventing an increase in said angle of said load face when said distance between said material handling vehicle lateral datum and said load face lateral datum corresponds to said limit.

37. *The system of claim 1 where the first side shift limit and the second side shift limit at said height datum are each predetermined prior to a time that the material handling vehicle engages a load.*

38. *The load handling attachment of claim 21 where the first side shift limit and the second side shift limit at said height datum are each predetermined prior to a time that the load handling attachment engages a load.*

39. *The method of claim 31 where the limit at said height datum is predetermined prior to a time that the material handling vehicle engages a load.*

* * * * *