



US00RE48963E

(19) **United States**
(12) **Reissued Patent**
Bathiche et al.

(10) **Patent Number:** **US RE48,963 E**
(45) **Date of Reissued Patent:** **Mar. 8, 2022**

(54) **CONNECTION DEVICE FOR COMPUTING DEVICES**

(58) **Field of Classification Search**
CPC G06F 1/1654; G06F 1/1669; G06F 1/1618;
G06F 1/1683; G06F 1/1637; G06F 1/1616

(71) Applicant: **Microsoft Technology Licensing, LLC**,
Redmond, WA (US)

See application file for complete search history.

(72) Inventors: **Steven Nabil Bathiche**, Kirkland, WA (US); **Flavio Protasio Ribeiro**, Bellevue, WA (US); **Nigel Stuart Keam**, Redmond, WA (US); **Bernard K. Rihn**, Snohomish, WA (US); **Panos C. Panay**, Redmond, WA (US); **David W. Voth**, Woodinville, WA (US)

(56) **References Cited**

U.S. PATENT DOCUMENTS

578,325 A 3/1897 Fleming
3,600,528 A 8/1971 Leposavic
(Continued)

FOREIGN PATENT DOCUMENTS

(73) Assignee: **Microsoft Technology Licensing, LLC**,
Redmond, WA (US)

CA 990023 6/1976
CN 1653411 8/2005
(Continued)

(21) Appl. No.: **16/846,055**

OTHER PUBLICATIONS

(22) Filed: **Apr. 10, 2020**

“Office Action Issued in Korean Patent Application No. 10-2020-7016522”, dated Jul. 25, 2020, 26 Pages.

Related U.S. Patent Documents

(Continued)

Reissue of:

(64) Patent No.: **9,426,905**
Issued: **Aug. 23, 2016**
Appl. No.: **13/891,109**
Filed: **May 9, 2013**

Primary Examiner — Terrence R Till
(74) *Attorney, Agent, or Firm* — Ray Quinney & Nebeker P.C.; Paul N. Taylor

U.S. Applications:

(63) Continuation-in-part of application No. 13/470,633, filed on May 14, 2012, now Pat. No. 8,498,100.
(Continued)

(51) **Int. Cl.**
G06F 1/16 (2006.01)
H01R 11/30 (2006.01)
(Continued)

(57) **ABSTRACT**

A connection device for computing devices is described. In one or more implementations, a connection device comprises a plurality of connection portions that are physically and communicatively coupled, one to another. Each of the plurality of connection portions has at least one communication contact configured to form a communicative coupling with a respective one of a plurality of computing devices and with at least one other communication contact of another one of the connections portions to support communication between the plurality of computing devices. Each of the plurality of connection portions also includes a magnetic coupling device to form a removable magnetic attachment to the respective one of the plurality of computing devices.

(52) **U.S. Cl.**
CPC **G06F 1/1683** (2013.01); **G06F 1/1626** (2013.01); **G06F 1/1637** (2013.01);
(Continued)

18 Claims, 12 Drawing Sheets

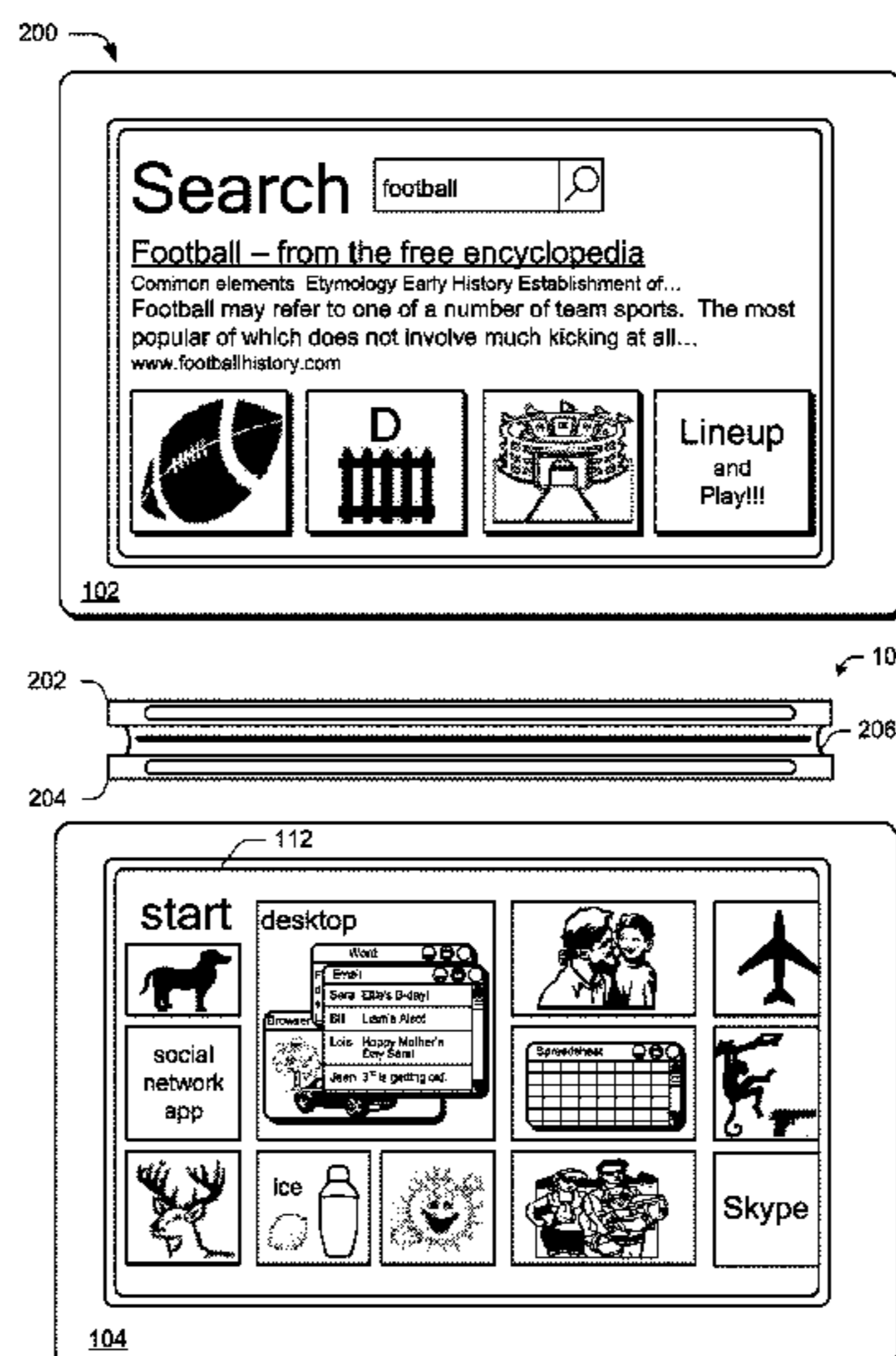

- Related U.S. Application Data**
- (60) Provisional application No. 61/606,321, filed on Mar. 2, 2012, provisional application No. 61/606,301, filed on Mar. 2, 2012, provisional application No. 61/606,313, filed on Mar. 2, 2012, provisional application No. 61/606,333, filed on Mar. 2, 2012, provisional application No. 61/613,745, filed on Mar. 21, 2012, provisional application No. 61/606,336, filed on Mar. 2, 2012, provisional application No. 61/607,451, filed on Mar. 6, 2012.
- (51) **Int. Cl.**
H01R 13/62 (2006.01)
H05K 5/00 (2006.01)
- (52) **U.S. Cl.**
 CPC *G06F 1/1654* (2013.01); *G06F 1/1679* (2013.01); *G06F 1/1681* (2013.01); *G06F 1/1692* (2013.01); *H01R 11/30* (2013.01); *H01R 13/6205* (2013.01); *H05K 5/0086* (2013.01)

	5,404,133	A	4/1995	Moriike et al.
	5,480,118	A	1/1996	Cross
	5,491,313	A	2/1996	Bartley et al.
	5,510,783	A	4/1996	Findlater et al.
	5,546,271	A	8/1996	Gut et al.
	5,548,477	A	8/1996	Kumar et al.
	5,558,577	A	9/1996	Kato
	5,574,447	A	11/1996	Roylance
	5,576,981	A	11/1996	Parker et al.
	5,581,682	A	12/1996	Anderson et al.
	5,596,700	A	1/1997	Darnell et al.
	5,618,232	A	4/1997	Martin
	5,661,279	A	8/1997	Kenmochi
	5,666,112	A	9/1997	Crowley et al.
	5,681,220	A	10/1997	Bertram et al.
	5,737,183	A	4/1998	Kobayashi et al.
	5,745,376	A	4/1998	Barker et al.
	5,748,114	A	5/1998	Koehn
	5,781,406	A	7/1998	Hunte
	5,803,748	A	9/1998	Maddrell et al.
	5,807,175	A	9/1998	Davis et al.
	5,818,361	A	10/1998	Acevedo
	5,828,770	A	10/1998	Leis et al.
	5,842,027	A	11/1998	Oprescu et al.
	5,861,990	A	1/1999	Tedesco
	5,874,697	A	2/1999	Selker et al.
	5,905,485	A	5/1999	Podoloff
	5,920,317	A	7/1999	McDonald
	5,924,555	A	7/1999	Sadamori et al.
	5,926,170	A	7/1999	Oba
	5,957,191	A	9/1999	Okada et al.
	5,971,635	A	10/1999	Wise
	6,002,389	A	12/1999	Kasser
	6,002,581	A	12/1999	Lindsey
	6,005,209	A	12/1999	Burleson et al.
	6,012,714	A	1/2000	Worley et al.
	6,040,823	A	3/2000	Seffernick et al.
	6,042,075	A	3/2000	Burch, Jr.
	6,044,717	A	4/2000	Biegelsen et al.
	6,061,644	A	5/2000	Leis
	6,108,200	A	8/2000	Fullerton
	6,112,797	A	9/2000	Colson et al.
	6,128,007	A	10/2000	Seybold
	6,137,675	A *	10/2000	Perkins G06F 1/163 128/876
	6,141,388	A	10/2000	Servais et al.
	6,147,859	A	11/2000	Abboud
	6,178,085	B1	1/2001	Leung
	6,178,443	B1	1/2001	Lin
	6,188,391	B1	2/2001	Seely et al.
	6,198,474	B1	3/2001	Roylance
	6,228,926	B1	5/2001	Golumbic
	6,254,105	B1	7/2001	Rinde et al.
	6,266,685	B1	7/2001	Danielson et al.
	6,279,060	B1	8/2001	Luke et al.
	6,305,073	B1	10/2001	Badders
	6,329,617	B1	12/2001	Burgess
	6,344,791	B1	2/2002	Armstrong
	6,366,440	B1	4/2002	Kung
	6,380,497	B1	4/2002	Hashimoto et al.
	6,437,682	B1	8/2002	Vance
	6,442,764	B1	9/2002	Badillo et al.
	6,450,046	B1	9/2002	Maeda
	6,469,755	B1	10/2002	Adachi et al.
	6,506,983	B1	1/2003	Babb et al.
	6,511,378	B1	1/2003	Bhatt et al.
	6,532,147	B1	3/2003	Christ, Jr.
	6,543,949	B1	4/2003	Ritchey et al.
	6,565,439	B2	5/2003	Shinohara et al.
	6,585,435	B2	7/2003	Fang
	6,597,347	B1	7/2003	Yasutake
	6,600,121	B1	7/2003	Olodort et al.
	6,603,408	B1	8/2003	Gaba
	6,603,461	B2	8/2003	Smith, Jr. et al.
	6,608,664	B1	8/2003	Hasegawa
	6,617,536	B2	9/2003	Kawaguchi
	6,651,943	B2	11/2003	Cho et al.
	6,675,865	B1	1/2004	Yoshida
	6,684,166	B2	1/2004	Bellwood et al.

(56) **References Cited**

U.S. PATENT DOCUMENTS

	3,777,082	A	12/1973	Hatley
	3,879,586	A	4/1975	DuRocher et al.
	3,968,336	A	7/1976	Johnson
	4,046,975	A	9/1977	Seeger, Jr.
	4,065,649	A	12/1977	Carter et al.
	4,086,451	A	4/1978	Boulanger
	4,243,861	A	1/1981	Strandwitz
	4,279,021	A	7/1981	See et al.
	4,302,648	A	11/1981	Sado et al.
	4,317,013	A	2/1982	Larson
	4,323,740	A	4/1982	Balash
	4,326,193	A	4/1982	Markley et al.
	4,365,130	A	12/1982	Christensen
	4,375,018	A	2/1983	Petersen
	4,420,744	A	12/1983	Jesson
	4,492,829	A	1/1985	Rodrique
	4,503,294	A	3/1985	Matsumaru
	4,527,021	A	7/1985	Morikawa et al.
	4,559,426	A	12/1985	Van Zeeland et al.
	4,577,822	A	3/1986	Wilkerson
	4,588,187	A	5/1986	Dell
	4,602,135	A	7/1986	Phalen
	4,607,147	A	8/1986	Ono et al.
	4,651,133	A	3/1987	Ganesan et al.
	4,652,704	A	3/1987	Franklin
	4,684,767	A	8/1987	Phalen
	4,724,605	A	2/1988	Fiorella
	4,735,394	A	4/1988	Facco
	4,795,977	A *	1/1989	Frost G01R 1/073 324/537
	4,801,771	A	1/1989	Mizuguchi et al.
	4,824,268	A	4/1989	Diernisse H. V.
	4,864,084	A	9/1989	Cardinale
	5,008,497	A	4/1991	Asher
	5,021,638	A	6/1991	Nopper et al.
	5,107,401	A	4/1992	Youn
	5,128,829	A	7/1992	Loew
	5,138,119	A	8/1992	Demeo
	5,204,517	A	4/1993	Cates et al.
	5,218,177	A	6/1993	Coleman et al.
	5,220,318	A	6/1993	Staley
	5,220,521	A	6/1993	Kikinis
	5,235,495	A	8/1993	Blair et al.
	5,253,362	A	10/1993	Nolan et al.
	5,283,559	A	2/1994	Kalendra et al.
	5,331,443	A	7/1994	Stanisci
	5,340,528	A	8/1994	Machida et al.
	5,363,075	A	11/1994	Fanucchi
	5,375,076	A	12/1994	Goodrich et al.

(56)

References Cited

U.S. PATENT DOCUMENTS

6,685,369 B2	2/2004	Lien	7,499,037 B2	3/2009	Lube	
6,687,614 B2	2/2004	Ihara et al.	7,502,803 B2	3/2009	Culter et al.	
6,695,273 B2	2/2004	Iguchi	7,542,052 B2	6/2009	Solomon et al.	
6,704,864 B1	3/2004	Philyaw	7,558,594 B2	7/2009	Wilson	
6,721,019 B2	4/2004	Kono et al.	7,559,834 B1	7/2009	York	
6,725,318 B1	4/2004	Sherman et al.	RE40,891 E	9/2009	Yasutake	
6,738,049 B2	5/2004	Kiser et al.	7,583,500 B2 *	9/2009	Ligtenberg	G06F 1/1616
6,758,615 B2	7/2004	Monney et al.				361/147
6,774,888 B1	8/2004	Genduso	7,594,638 B2	9/2009	Chan et al.	
6,776,546 B2	8/2004	Kraus et al.	7,620,244 B1	11/2009	Collier	
6,780,019 B1	8/2004	Ghosh et al.	7,622,907 B2	11/2009	Vranish	
6,781,819 B2	8/2004	Yang et al.	7,623,121 B2	11/2009	Dodge	
6,784,869 B1	8/2004	Clark et al.	7,626,358 B2	12/2009	Lam et al.	
6,798,887 B1	9/2004	Andre	7,636,921 B2	12/2009	Louie	
6,813,143 B2	11/2004	Makela	7,639,329 B2	12/2009	Takeda et al.	
6,819,316 B2	11/2004	Schulz et al.	7,639,876 B2	12/2009	Clary et al.	
6,819,547 B2	11/2004	Minaguchi et al.	7,656,392 B2	2/2010	Bolender	
6,856,506 B2	2/2005	Doherty et al.	7,686,066 B2	3/2010	Hirao	
6,856,789 B2	2/2005	Pattabiraman et al.	7,722,358 B2	5/2010	Chatterjee et al.	
6,861,961 B2	3/2005	Sandbach et al.	7,722,792 B2	5/2010	Uezaki et al.	
6,864,573 B2	3/2005	Robertson et al.	7,728,923 B2	6/2010	Kim et al.	
6,882,337 B2	4/2005	Shetter	7,729,493 B2	6/2010	Krieger et al.	
6,898,315 B2	5/2005	Guha	7,731,147 B2	6/2010	Rha	
6,909,354 B2	6/2005	Baker et al.	7,733,326 B1	6/2010	Adishesan	
6,914,197 B2	7/2005	Doherty et al.	7,761,119 B2	7/2010	Patel	
6,948,136 B2	9/2005	Trewin	7,773,076 B2	8/2010	Pittel et al.	
6,950,950 B2	9/2005	Sawyers et al.	7,773,121 B1	8/2010	Huntsberger et al.	
6,962,454 B1	11/2005	Costello	7,774,155 B2	8/2010	Sato et al.	
6,970,957 B1	11/2005	Oshins et al.	7,777,972 B1	8/2010	Chen et al.	
6,976,799 B2	12/2005	Kim et al.	7,782,342 B2	8/2010	Koh	
7,007,238 B2	2/2006	Glaser	7,813,715 B2	10/2010	McKillop et al.	
7,018,678 B2	3/2006	Gronbeck et al.	7,815,358 B2	10/2010	Inditsky	
7,051,149 B2	5/2006	Wang et al.	7,817,428 B2	10/2010	Greer, Jr. et al.	
7,066,634 B2	6/2006	Kitamura et al.	7,822,338 B2	10/2010	Wernersson	
7,068,496 B2	6/2006	Wong et al.	7,865,639 B2	1/2011	McCoy et al.	
7,083,295 B1	8/2006	Hanna	7,884,807 B2	2/2011	Hovden et al.	
7,091,436 B2	8/2006	Serban	7,893,921 B2	2/2011	Sato	
7,091,955 B2	8/2006	Kramer	7,907,394 B2	3/2011	Richardson et al.	
7,095,404 B2	8/2006	Vincent et al.	D636,397 S	4/2011	Green	
7,099,149 B2	8/2006	Krieger et al.	7,928,964 B2	4/2011	Kolmykov-Zotov et al.	
7,106,222 B2	9/2006	Ward et al.	7,932,890 B2	4/2011	Onikiri et al.	
7,116,309 B1	10/2006	Kimura et al.	7,936,501 B2	5/2011	Smith et al.	
7,123,241 B2	10/2006	Bathiche	7,944,520 B2	5/2011	Ichioka et al.	
7,123,292 B1	10/2006	Seeger et al.	7,945,717 B2	5/2011	Rivalsi	
7,136,282 B1	11/2006	Rebeske	7,967,462 B2	6/2011	Ogiro et al.	
7,152,985 B2	12/2006	Benitez et al.	7,970,246 B2	6/2011	Travis et al.	
D535,292 S	1/2007	Shi et al.	7,973,771 B2	7/2011	Geaghan	
7,169,460 B1	1/2007	Chen et al.	7,978,281 B2	7/2011	Vergith et al.	
7,194,662 B2	3/2007	Do et al.	8,016,255 B2	9/2011	Lin	
7,201,508 B2	4/2007	Misaras	8,018,386 B2	9/2011	Qi et al.	
7,202,837 B2	4/2007	Ihara	8,018,579 B1	9/2011	Krah	
7,213,323 B2	5/2007	Baker et al.	8,026,904 B2	9/2011	Westerman	
7,213,991 B2	5/2007	Chapman et al.	8,053,688 B2	11/2011	Conzola et al.	
7,218,830 B2	5/2007	Iimura	8,059,384 B2	11/2011	Park et al.	
7,224,830 B2	5/2007	Nefian et al.	8,065,624 B2	11/2011	Morin et al.	
7,239,505 B2	7/2007	Keely et al.	8,069,356 B2	11/2011	Rathi et al.	
7,252,512 B2	8/2007	Tai et al.	8,077,160 B2	12/2011	Land et al.	
7,260,221 B1	8/2007	Atsmon	8,090,885 B2	1/2012	Callaghan et al.	
7,277,087 B2	10/2007	Hill et al.	8,098,233 B2	1/2012	Hotelling et al.	
7,301,759 B2	11/2007	Hsiung	8,115,499 B2	2/2012	Osoinach et al.	
7,365,967 B2	4/2008	Zheng	8,117,362 B2	2/2012	Rodriguez et al.	
7,374,312 B2	5/2008	Feng et al.	8,118,274 B2	2/2012	McClure et al.	
7,400,805 B2	7/2008	Abu-Ageel	8,120,166 B2	2/2012	Koizumi et al.	
7,401,992 B1	7/2008	Lin	8,130,203 B2	3/2012	Westerman	
7,415,676 B2	8/2008	Fujita	8,149,219 B2	4/2012	Lii et al.	
7,417,564 B2	8/2008	Tolonen et al.	8,154,524 B2	4/2012	Wilson et al.	
7,417,626 B2	8/2008	Bhesania et al.	8,159,372 B2	4/2012	Sherman	
7,423,557 B2	9/2008	Kang	8,162,282 B2	4/2012	Hu et al.	
7,437,193 B2	10/2008	Parramon et al.	D659,139 S	5/2012	Gengler	
7,447,934 B2	11/2008	Dasari et al.	8,169,421 B2	5/2012	Wright et al.	
7,453,376 B2	11/2008	De	8,189,973 B2	5/2012	Travis et al.	
7,457,108 B2	11/2008	Ghosh	8,229,509 B2	7/2012	Paek et al.	
7,469,386 B2	12/2008	Bear et al.	8,229,522 B2	7/2012	Kim et al.	
7,486,165 B2	2/2009	Ligtenberg et al.	8,231,099 B2	7/2012	Chen	
7,486,276 B2	2/2009	Yajima et al.	8,243,432 B2	8/2012	Duan et al.	
			8,248,791 B2	8/2012	Wang et al.	
			8,255,708 B1	8/2012	Zhang	
			8,263,730 B2	9/2012	Shimizu	
			8,264,310 B2	9/2012	Lauder et al.	

(56)

References Cited

U.S. PATENT DOCUMENTS		
2006/0085658	A1	4/2006 Allen et al.
2006/0092139	A1	5/2006 Sharma
2006/0096392	A1	5/2006 Inkster et al.
2006/0102914	A1	5/2006 Smits et al.
2006/0103633	A1	5/2006 Gioeli
2006/0125799	A1	6/2006 Hillis et al.
2006/0132423	A1	6/2006 Travis
2006/0152499	A1	7/2006 Roberts
2006/0154725	A1	7/2006 Glaser et al.
2006/0155391	A1	7/2006 Pistemaa et al.
2006/0156415	A1	7/2006 Rubinstein et al.
2006/0174143	A1	8/2006 Sawyers et al.
2006/0176377	A1	8/2006 Miyasaka
2006/0181514	A1	8/2006 Newman
2006/0181521	A1	8/2006 Perreault et al.
2006/0187216	A1	8/2006 Trent, Jr. et al.
2006/0192763	A1	8/2006 Ziemkowski
2006/0195522	A1	8/2006 Miyazaki
2006/0197755	A1	9/2006 Bawany
2006/0227393	A1	10/2006 Herloski
2006/0238510	A1	10/2006 Panotopoulos et al.
2006/0239006	A1	10/2006 Chaves et al.
2006/0254042	A1	11/2006 Chou et al.
2006/0265617	A1	11/2006 Priborsky
2006/0267931	A1	11/2006 Vainio et al.
2006/0272429	A1	12/2006 Ganapathi et al.
2007/0003267	A1	1/2007 Shibutani
2007/0047221	A1	3/2007 Park
2007/0047260	A1	3/2007 Lee et al.
2007/0051766	A1	3/2007 Spencer
2007/0051792	A1	3/2007 Wheeler et al.
2007/0056385	A1	3/2007 Lorenz
2007/0062089	A1	3/2007 Homer et al.
2007/0069153	A1	3/2007 Pai-Paranjape et al.
2007/0072474	A1	3/2007 Beasley et al.
2007/0116929	A1	5/2007 Fujimori et al.
2007/0117600	A1	5/2007 Robertson et al.
2007/0121956	A1	5/2007 Bai et al.
2007/0145945	A1	6/2007 McGinley et al.
2007/0172229	A1	7/2007 Wernersson
2007/0176902	A1	8/2007 Newman et al.
2007/0178891	A1	8/2007 Louch et al.
2007/0182663	A1	8/2007 Biech
2007/0182722	A1	8/2007 Hotelling et al.
2007/0185590	A1	8/2007 Reindel et al.
2007/0188478	A1	8/2007 Silverstein et al.
2007/0200830	A1	8/2007 Yamamoto
2007/0220708	A1	9/2007 Lewis
2007/0230227	A1	10/2007 Palmer
2007/0234420	A1	10/2007 Novotney et al.
2007/0236408	A1	10/2007 Yamaguchi et al.
2007/0236475	A1	10/2007 Wherry
2007/0236873	A1	10/2007 Yukawa et al.
2007/0247338	A1	10/2007 Marchetto
2007/0247432	A1	10/2007 Oakley
2007/0252674	A1	11/2007 Nelson et al.
2007/0257821	A1	11/2007 Son et al.
2007/0260892	A1	11/2007 Paul et al.
2007/0268273	A1	11/2007 Westerman et al.
2007/0274094	A1	11/2007 Schultz et al.
2007/0274095	A1	11/2007 Destain
2007/0283179	A1	12/2007 Burnett et al.
2007/0296709	A1	12/2007 Guanghai
2007/0297125	A1	12/2007 Maatta
2007/0297625	A1	12/2007 Hjort et al.
2008/0005423	A1	1/2008 Jacobs et al.
2008/0013809	A1	1/2008 Zhu et al.
2008/0018611	A1	1/2008 Serban et al.
2008/0030937	A1	2/2008 Russo et al.
2008/0042978	A1	2/2008 Perez-Noguera
2008/0053222	A1	3/2008 Ehrensvarid et al.
2008/0059888	A1	3/2008 Dunko
2008/0074398	A1	3/2008 Wright
2008/0080166	A1	4/2008 Duong et al.
2008/0104437	A1	5/2008 Lee
2008/0129520	A1	6/2008 Lee
2008/0151478	A1	6/2008 Chern, Jr.
2008/0158185	A1	7/2008 Westerman
2008/0167832	A1	7/2008 Soss
2008/0174570	A1	7/2008 Jobs et al.
2008/0180411	A1	7/2008 Solomon et al.
2008/0186660	A1	8/2008 Yang
2008/0219025	A1	9/2008 Spitzer et al.
2008/0228969	A1	9/2008 Cheah et al.
2008/0232061	A1	9/2008 Wang et al.
2008/0233326	A1	9/2008 Hegemier et al.
2008/0238884	A1	10/2008 Harish
2008/0253822	A1	10/2008 Matias
2008/0273297	A1	11/2008 Kumar
2008/0297878	A1	12/2008 Brown et al.
2008/0307242	A1	12/2008 Qu
2008/0309636	A1	12/2008 Feng et al.
2008/0316002	A1	12/2008 Brunet et al.
2008/0316183	A1	12/2008 Westerman et al.
2008/0320190	A1	12/2008 Lydon et al.
2009/0002218	A1	1/2009 Rigazio et al.
2009/0007001	A1	1/2009 Morin et al.
2009/0009476	A1	1/2009 Daley, III
2009/0020343	A1	1/2009 Rothkopf et al.
2009/0046416	A1	2/2009 Daley, III
2009/0049979	A1	2/2009 Naik et al.
2009/0065267	A1	3/2009 Sato
2009/0066653	A1	3/2009 Wang
2009/0067156	A1	3/2009 Bonnett et al.
2009/0073060	A1	3/2009 Shimasaki et al.
2009/0073957	A1	3/2009 Newland et al.
2009/0079639	A1	3/2009 Hotta et al.
2009/0083562	A1	3/2009 Park et al.
2009/0089600	A1	4/2009 Nousiainen
2009/0102794	A1	4/2009 Lapstun et al.
2009/0102805	A1	4/2009 Meijer et al.
2009/0127005	A1	5/2009 Zachut et al.
2009/0131134	A1	5/2009 Baerlocher et al.
2009/0135142	A1	5/2009 Fu et al.
2009/0140985	A1	6/2009 Liu
2009/0158221	A1	6/2009 Nielsen et al.
2009/0163147	A1	6/2009 Steigerwald et al.
2009/0167728	A1	7/2009 Geaghan et al.
2009/0174687	A1	7/2009 Ciesla et al.
2009/0174759	A1	7/2009 Yeh et al.
2009/0182901	A1	7/2009 Callaghan et al.
2009/0189873	A1	7/2009 Peterson et al.
2009/0195497	A1	8/2009 Fitzgerald et al.
2009/0195518	A1	8/2009 Mattice et al.
2009/0201254	A1	8/2009 Rais
2009/0207144	A1	8/2009 Bridger
2009/0219250	A1	9/2009 Ure
2009/0231275	A1	9/2009 Odgers
2009/0239586	A1	9/2009 Boeve et al.
2009/0244009	A1	10/2009 Staats et al.
2009/0244832	A1	10/2009 Behar et al.
2009/0244872	A1	10/2009 Yan
2009/0251008	A1	10/2009 Sugaya
2009/0259865	A1	10/2009 Sheynblat et al.
2009/0262492	A1	10/2009 Whitchurch et al.
2009/0265670	A1	10/2009 Kim et al.
2009/0269943	A1*	10/2009 Palli H01R 13/6205 439/39
2009/0285491	A1	11/2009 Ravenscroft et al.
2009/0296331	A1	12/2009 Choy
2009/0303137	A1	12/2009 Kusaka et al.
2009/0303204	A1	12/2009 Nasiri et al.
2009/0315830	A1	12/2009 Westerman
2009/0320244	A1	12/2009 Lin
2009/0321490	A1	12/2009 Groene et al.
2010/0001963	A1	1/2010 Doray et al.
2010/0013319	A1	1/2010 Kamiyama et al.
2010/0021022	A1	1/2010 Pittel et al.
2010/0023869	A1	1/2010 Saint-Hilaire et al.
2010/0026656	A1	2/2010 Hotelling et al.
2010/0038821	A1	2/2010 Jenkins et al.
2010/0039081	A1	2/2010 Sip
2010/0039764	A1	2/2010 Locker et al.
2010/0045540	A1	2/2010 Lai et al.

(56)

References Cited

U.S. PATENT DOCUMENTS					
2010/0045609	A1	2/2010 Do et al.	2010/0308844	A1	12/2010 Day et al.
2010/0045633	A1	2/2010 Gettemy	2010/0309617	A1	12/2010 Wang et al.
2010/0051356	A1	3/2010 Stern et al.	2010/0313680	A1	12/2010 Joung et al.
2010/0051432	A1	3/2010 Lin et al.	2010/0315348	A1	12/2010 Jellicoe et al.
2010/0052880	A1	3/2010 Laitinen et al.	2010/0315373	A1	12/2010 Steinhauer et al.
2010/0053534	A1	3/2010 Hsieh et al.	2010/0321301	A1	12/2010 Casparian et al.
2010/0054435	A1	3/2010 Louch et al.	2010/0321339	A1	12/2010 Kimmel
2010/0056130	A1	3/2010 Louch et al.	2010/0321877	A1	12/2010 Moser
2010/0072334	A1	3/2010 Le Gette et al.	2010/0324457	A1	12/2010 Bean et al.
2010/0073329	A1	3/2010 Raman et al.	2010/0325155	A1	12/2010 Skinner et al.
2010/0075517	A1	3/2010 Ni et al.	2010/0328203	A1	12/2010 Hsu
2010/0077237	A1	3/2010 Sawyers	2010/0331059	A1	12/2010 Apgar et al.
2010/0079379	A1	4/2010 Demuynck et al.	2011/0007008	A1	1/2011 Algreatly
2010/0081377	A1	4/2010 Chatterjee et al.	2011/0012873	A1	1/2011 Prest et al.
2010/0083108	A1	4/2010 Rider et al.	2011/0019123	A1	1/2011 Prest et al.
2010/0085321	A1	4/2010 Pundsack	2011/0031287	A1	2/2011 Le Gette et al.
2010/0102182	A1	4/2010 Lin	2011/0032127	A1	2/2011 Roush
2010/0103112	A1	4/2010 Yoo et al.	2011/0036965	A1	2/2011 Zhang et al.
2010/0103131	A1	4/2010 Segal et al.	2011/0037721	A1	2/2011 Cranfill et al.
2010/0105443	A1	4/2010 Vaisanen	2011/0043990	A1	2/2011 Mickey et al.
2010/0106983	A1	4/2010 Kasprzak et al.	2011/0050576	A1	3/2011 Forutanpour et al.
2010/0115309	A1	5/2010 Carvalho et al.	2011/0050587	A1	3/2011 Natanzon et al.
2010/0117993	A1	5/2010 Kent	2011/0050626	A1	3/2011 Porter et al.
2010/0123686	A1	5/2010 Klinghult et al.	2011/0055407	A1	3/2011 Lydon et al.
2010/0128427	A1	5/2010 Iso	2011/0057724	A1	3/2011 Pabon
2010/0133398	A1	6/2010 Chiu et al.	2011/0057899	A1	3/2011 Sleeman et al.
2010/0142130	A1	6/2010 Wang et al.	2011/0060926	A1	3/2011 Brooks et al.
2010/0148995	A1	6/2010 Elias	2011/0069148	A1	3/2011 Jones et al.
2010/0148999	A1	6/2010 Casparian et al.	2011/0074688	A1	3/2011 Hull et al.
2010/0149104	A1	6/2010 Sim et al.	2011/0095994	A1	4/2011 Birnbaum
2010/0149111	A1	6/2010 Olien	2011/0096513	A1	4/2011 Kim H04M 1/0254
2010/0149134	A1	6/2010 Westerman et al.			361/747
2010/0149377	A1	6/2010 Shintani et al.	2011/0102326	A1	5/2011 Casparian et al.
2010/0154171	A1	6/2010 Lombardi et al.	2011/0102356	A1	5/2011 Kemppinen et al.
2010/0156798	A1	6/2010 Archer	2011/0102752	A1	5/2011 Chen et al.
2010/0156913	A1	6/2010 Ortega et al. G06F 3/1423 345/520	2011/0107958	A1	5/2011 Pance et al.
2010/0161522	A1	6/2010 Tirpak et al.	2011/0113368	A1	5/2011 Carvajal et al.
2010/0162109	A1	6/2010 Chatterjee et al.	2011/0115738	A1	5/2011 Suzuki et al.
2010/0164857	A1	7/2010 Liu et al.	2011/0115747	A1	5/2011 Powell et al.
2010/0164897	A1	7/2010 Morin et al.	2011/0117970	A1	5/2011 Choi
2010/0171891	A1	7/2010 Kaji et al.	2011/0134032	A1	6/2011 Chiu et al.
2010/0174421	A1	7/2010 Tsai et al.	2011/0134043	A1	6/2011 Chen
2010/0180063	A1	7/2010 Ananny et al.	2011/0134112	A1	6/2011 Koh et al.
2010/0188299	A1	7/2010 Rinehart et al.	2011/0157046	A1	6/2011 Lee et al.
2010/0188338	A1	7/2010 Longe	2011/0157087	A1	6/2011 Kanehira et al.
2010/0205472	A1	8/2010 Tupman et al.	2011/0163955	A1	7/2011 Nasiri et al.
2010/0206614	A1	8/2010 Park et al.	2011/0164370	A1	7/2011 McClure et al.
2010/0206644	A1	8/2010 Yeh	2011/0167181	A1	7/2011 Minoos et al.
2010/0214214	A1	8/2010 Corson et al.	2011/0167287	A1	7/2011 Walsh et al.
2010/0214257	A1	8/2010 Wussler et al.	2011/0167391	A1	7/2011 Momeyer et al.
2010/0222110	A1	9/2010 Kim et al.	2011/0167992	A1	7/2011 Eventoff et al.
2010/0231498	A1	9/2010 Large et al.	2011/0169762	A1	7/2011 Weiss
2010/0231510	A1	9/2010 Sampsel et al.	2011/0170289	A1	7/2011 Allen et al.
2010/0231556	A1	9/2010 Mines et al.	2011/0176035	A1	7/2011 Poulsen
2010/0235546	A1	9/2010 Terlizzi et al.	2011/0179864	A1	7/2011 Raasch et al.
2010/0238075	A1	9/2010 Pourseyed	2011/0183120	A1	7/2011 Sharygin et al.
2010/0238119	A1	9/2010 Dubrovsky et al.	2011/0184646	A1	7/2011 Wong et al.
2010/0238138	A1	9/2010 Goertz et al.	2011/0184824	A1	7/2011 George et al.
2010/0238620	A1	9/2010 Fish	2011/0188199	A1	8/2011 Pan
2010/0245221	A1	9/2010 Khan	2011/0193787	A1	8/2011 Morishige et al.
2010/0250988	A1	9/2010 Okuda et al.	2011/0193938	A1	8/2011 Oderwald et al.
2010/0259482	A1	10/2010 Ball	2011/0199389	A1	8/2011 Lu et al.
2010/0259876	A1	10/2010 Kim	2011/0202878	A1	8/2011 Park et al.
2010/0265182	A1	10/2010 Ball et al.	2011/0205372	A1	8/2011 Miramontes
2010/0271771	A1	10/2010 Wu et al.	2011/0216266	A1	9/2011 Travis
2010/0274932	A1	10/2010 Kose	2011/0221678	A1	9/2011 Davydov
2010/0279768	A1	11/2010 Huang et al.	2011/0227913	A1	9/2011 Hyndman
2010/0289457	A1	11/2010 Onnerud et al.	2011/0228457	A1	9/2011 Moon et al.
2010/0291331	A1	11/2010 Schaefer	2011/0231682	A1	9/2011 Kakish et al.
2010/0295812	A1	11/2010 Burns et al.	2011/0234494	A1	9/2011 Peterson et al.
2010/0302378	A1	12/2010 Marks et al.	2011/0234502	A1	9/2011 Yun et al.
2010/0304793	A1	12/2010 Kim	2011/0242138	A1	10/2011 Tribble
2010/0306538	A1	12/2010 Thomas et al.	2011/0248152	A1	10/2011 Svajda et al.
2010/0308778	A1	12/2010 Yamazaki et al.	2011/0248920	A1	10/2011 Larsen
			2011/0248941	A1	10/2011 Abdo et al.
			2011/0259788	A1	10/2011 Zelif et al.
			2011/0261001	A1	10/2011 Liu
			2011/0261083	A1	10/2011 Wilson
			2011/0265287	A1	11/2011 Li et al.

US RE48,963 E

Page 7

(56)

References Cited

U.S. PATENT DOCUMENTS

2011/0266672	A1	11/2011	Sylvester	2012/0218194	A1	8/2012	Silverman
2011/0267272	A1	11/2011	Meyer et al.	2012/0223866	A1	9/2012	Ayala et al.
2011/0267300	A1	11/2011	Serban et al.	2012/0224073	A1	9/2012	Miyahara
2011/0273475	A1	11/2011	Herz et al.	2012/0227259	A1	9/2012	Badaye et al.
2011/0284420	A1	11/2011	Sajid	2012/0229634	A1	9/2012	Laett et al.
2011/0290686	A1	12/2011	Huang	2012/0235635	A1	9/2012	Sato
2011/0295697	A1	12/2011	Boston et al.	2012/0235921	A1	9/2012	Laubach
2011/0297566	A1	12/2011	Gallagher et al.	2012/0242584	A1	9/2012	Tuli
2011/0298919	A1	12/2011	Maglaque	2012/0243165	A1	9/2012	Chang et al.
2011/0302518	A1	12/2011	Zhang	2012/0243204	A1	9/2012	Robinson
2011/0304577	A1	12/2011	Brown	2012/0246377	A1	9/2012	Bhesania
2011/0304962	A1	12/2011	Su	2012/0249443	A1	10/2012	Anderson et al.
			G06F 1/1628	2012/0250873	A1	10/2012	Bakalos et al.
			361/679.01	2012/0256829	A1	10/2012	Dodge
				2012/0256959	A1	10/2012	Ye et al.
				2012/0260177	A1	10/2012	Sehrer
				2012/0268912	A1	10/2012	Minami et al.
				2012/0274811	A1	11/2012	Bakin
				2012/0287562	A1	11/2012	Wu et al.
				2012/0298491	A1	11/2012	Ozias et al.
				2012/0299872	A1	11/2012	Nishikawa et al.
				2012/0300275	A1	11/2012	Villardell et al.
				2012/0312955	A1	12/2012	Randolph
				2012/0326003	A1	12/2012	Solow et al.
				2012/0328349	A1	12/2012	Isaac et al.
				2013/0009413	A1	1/2013	Chiu et al.
				2013/0015311	A1	1/2013	Kim
				2013/0016468	A1	1/2013	Oh
				2013/0021289	A1	1/2013	Chen et al.
				2013/0027867	A1	1/2013	Lauder et al.
				2013/0044059	A1	2/2013	Fu
				2013/0044074	A1	2/2013	Park et al.
				2013/0046397	A1	2/2013	Fadell et al.
				2013/0050922	A1	2/2013	Lee et al.
				2013/0063873	A1	3/2013	Wodrich et al.
				2013/0067126	A1	3/2013	Casparian et al.
				2013/0069916	A1	3/2013	Estève
				2013/0073877	A1	3/2013	Radke
				2013/0076617	A1	3/2013	Csaszar et al.
				2013/0076635	A1	3/2013	Lin
				2013/0082824	A1	4/2013	Colley
				2013/0082950	A1	4/2013	Lim et al.
				2013/0088431	A1	4/2013	Ballagas et al.
				2013/0093388	A1	4/2013	Partovi
				2013/0100082	A1	4/2013	Bakin et al.
				2013/0106723	A1	5/2013	Bakken et al.
				2013/0106766	A1	5/2013	Yilmaz et al.
				2013/0107144	A1	5/2013	Marhefka et al.
				2013/0107572	A1	5/2013	Holman et al.
				2013/0118878	A1	5/2013	Purcocks
				2013/0135214	A1	5/2013	Li et al.
				2013/0154959	A1	6/2013	Lindsay et al.
				2013/0162554	A1	6/2013	Lauder et al.
				2013/0172906	A1	7/2013	Olson et al.
				2013/0191741	A1	7/2013	Dickinson et al.
				2013/0207937	A1	8/2013	Lutian et al.
				2013/0212483	A1	8/2013	Brakensiek et al.
				2013/0217451	A1	8/2013	Komiyama et al.
				2013/0222272	A1	8/2013	Martin, Jr.
				2013/0222274	A1	8/2013	Mori et al.
				2013/0222323	A1	8/2013	McKenzie
				2013/0227836	A1	9/2013	Whitt, III
				2013/0228023	A1	9/2013	Drasnin
				2013/0228433	A1	9/2013	Shaw
				2013/0228434	A1	9/2013	Whitt, III
				2013/0228435	A1	9/2013	Whitt, III
				2013/0228439	A1	9/2013	Whitt, III
				2013/0229100	A1	9/2013	Siddiqui
				2013/0229335	A1	9/2013	Whitman
				2013/0229347	A1	9/2013	Lutz, III
				2013/0229350	A1	9/2013	Shaw
				2013/0229351	A1	9/2013	Whitt, III
				2013/0229354	A1	9/2013	Whitt, III
				2013/0229356	A1	9/2013	Marwah
				2013/0229363	A1	9/2013	Whitman
				2013/0229366	A1	9/2013	Dighde
				2013/0229380	A1	9/2013	Lutz, III
				2013/0229386	A1	9/2013	Bathiche
				2013/0229534	A1	9/2013	Panay

US RE48,963 E

(56)

References Cited

U.S. PATENT DOCUMENTS

2013/0229568 A1 9/2013 Belesiu
2013/0229570 A1 9/2013 Beck et al.
2013/0229756 A1 9/2013 Whitt, III
2013/0229757 A1 9/2013 Whitt, III
2013/0229758 A1 9/2013 Belesiu
2013/0229759 A1 9/2013 Whitt, III
2013/0229760 A1 9/2013 Whitt, III
2013/0229761 A1 9/2013 Shaw
2013/0229762 A1 9/2013 Whitt, III
2013/0229773 A1 9/2013 Siddiqui
2013/0230346 A1 9/2013 Shaw
2013/0231755 A1 9/2013 Perek
2013/0232280 A1 9/2013 Perek
2013/0232348 A1 9/2013 Oler
2013/0232349 A1 9/2013 Oler
2013/0232350 A1 9/2013 Belesiu et al.
2013/0232353 A1 9/2013 Belesiu
2013/0232571 A1 9/2013 Belesiu
2013/0241860 A1 9/2013 Ciesla et al.
2013/0262886 A1 10/2013 Nishimura
2013/0278552 A1 10/2013 Kamin-Lyndgaard
2013/0300590 A1 11/2013 Dietz
2013/0300647 A1 11/2013 Drasnin
2013/0301199 A1 11/2013 Whitt
2013/0301206 A1 11/2013 Whitt
2013/0304941 A1 11/2013 Drasnin
2013/0304944 A1 11/2013 Young
2013/0321992 A1 12/2013 Liu et al.
2013/0322000 A1 12/2013 Whitt
2013/0322001 A1 12/2013 Whitt
2013/0329360 A1 12/2013 Aldana
2013/0332628 A1 12/2013 Panay
2013/0335330 A1 12/2013 Lane
2013/0335902 A1 12/2013 Campbell
2013/0335903 A1 12/2013 Raken
2013/0339757 A1 12/2013 Reddy
2013/0342464 A1 12/2013 Bathiche et al.
2013/0342465 A1 12/2013 Bathiche
2013/0342976 A1 12/2013 Chung
2013/0346636 A1 12/2013 Bathiche
2014/0012401 A1 1/2014 Perek
2014/0028635 A1 1/2014 Krah
2014/0029183 A1 1/2014 Ashcraft et al.
2014/0043275 A1 2/2014 Whitman
2014/0048399 A1 2/2014 Whitt, III
2014/0049894 A1 2/2014 Rihn
2014/0085814 A1 3/2014 Kielland
2014/0117928 A1 5/2014 Liao
2014/0118241 A1 5/2014 Chai
2014/0119802 A1 5/2014 Shaw
2014/0131000 A1 5/2014 Bornemann et al.
2014/0135060 A1 5/2014 Mercer
2014/0139989 A1 5/2014 Mori et al.
2014/0148938 A1 5/2014 Zhang
2014/0154523 A1 6/2014 Bornemann et al.
2014/0159867 A1* 6/2014 Sartee G08B 5/36
340/6.1
2014/0166227 A1 6/2014 Bornemann et al.
2014/0167585 A1 6/2014 Kuan et al.
2014/0185215 A1 7/2014 Whitt
2014/0185220 A1 7/2014 Whitt
2014/0204514 A1 7/2014 Whitt
2014/0204515 A1 7/2014 Whitt
2014/0233237 A1 8/2014 Lutian
2014/0247546 A1 9/2014 Whitt
2014/0248506 A1 9/2014 McCormack
2014/0291134 A1 10/2014 Whitt
2014/0293534 A1 10/2014 Siddiqui
2014/0313665 A1 10/2014 Delpier et al. G06F 1/1654
361/679.55
2014/0362506 A1 12/2014 Whitt, III et al.
2014/0372914 A1 12/2014 Byrd et al.
2014/0379942 A1 12/2014 Perek et al.
2015/0005953 A1 1/2015 Fadell et al.
2015/0036274 A1 2/2015 Belesiu et al.

2015/0234478 A1 8/2015 Belesiu et al.
2015/0261262 A1 9/2015 Whitt, III et al.
2015/0311014 A1 10/2015 Shaw et al.
2015/0378392 A1 12/2015 Siddiqui et al.
2016/0124467 A1 5/2016 Whitt et al.

FOREIGN PATENT DOCUMENTS

CN 1787605 6/2006
CN 101198925 6/2008
CN 101335147 12/2008
CN 101366001 2/2009
CN 101410781 4/2009
CN 101452334 6/2009
CN 101464750 6/2009
CN 101490642 7/2009
CN 101500388 8/2009
CN 101908428 12/2010
CN 102096494 6/2011
CN 201853163 6/2011
CN 102124532 7/2011
CN 102138113 7/2011
CN 102214040 10/2011
CN 202441167 9/2012
CN 103455149 12/2013
CN 203606723 5/2014
EP 0271956 6/1988
EP 645726 3/1995
EP 1003188 5/2000
EP 1223722 7/2002
EP 1480029 11/2004
EP 1591891 11/2005
EP 2006869 12/2008
EP 2009660 12/2008
EP 2026178 2/2009
EP 2353978 8/2011
EP 2378607 10/2011
EP 2400365 12/2011
EP 2423787 2/2012
GB 1100331 1/1968
GB 2123213 1/1984
GB 2178570 2/1987
GB 2305780 4/1997
GB 2402460 12/2004
GB 2482932 2/2012
JP 52107722 9/1977
JP 56108127 8/1981
JP 56159134 12/1981
JP 6014315 1/1985
JP 08273471 10/1996
JP 10326124 12/1998
JP 1173239 3/1999
JP 11338575 12/1999
JP 11345041 12/1999
JP 2000010654 1/2000
JP 2001142564 5/2001
JP 2001243707 A 9/2001
JP 2002170458 6/2002
JP 2004038950 2/2004
JP 2005117161 4/2005
JP 2006163459 6/2006
JP 2006294361 10/2006
JP 2010244514 10/2010
JP 2011027815 A 2/2011
JP 2003077368 3/2014
KR 20010107055 12/2001
KR 20040003709 A 1/2004
KR 20050014299 2/2005
KR 20060003093 1/2006
KR 20060055307 A 5/2006
KR 20080006404 1/2008
KR 20090029411 3/2009
KR 20100022059 2/2010
KR 20100067366 6/2010
KR 20100115675 10/2010
KR 1020110087178 8/2011
KR 20110109791 10/2011
KR 20110120002 11/2011
KR 20110122333 11/2011

(56)

References Cited

FOREIGN PATENT DOCUMENTS

KR	20110138943	A	12/2011
KR	101113530		2/2012
KR	20120015749	A	2/2012
NL	1038411		5/2012
WO	WO-9108915		6/1991
WO	WO-9919995		4/1999
WO	WO-03106134		12/2003
WO	WO-2005027696		3/2005
WO	WO-2006044818		4/2006
WO	WO-2007112172		10/2007
WO	WO-2008055039		5/2008
WO	2009020264	A1	2/2009
WO	WO-2009034484		3/2009
WO	WO-2010011983		1/2010
WO	WO-2010074116		7/2010
WO	WO-2010105272		9/2010
WO	WO-2011049609		4/2011
WO	WO-2012036717		3/2012
WO	WO-2013012699		1/2013
WO	WO-2013033067		3/2013
WO	WO-2014209818		12/2014

OTHER PUBLICATIONS

“Non Final Office Action Issued in U.S. Appl. No. 13/471,393”, dated Jul. 24, 2020, 22 Pages.

“Office Action Issued in European Patent Application No. 13858620.1”, dated Jul. 13, 2020, 5 Pages.

“Office Action Issued In Korean Patent Application No. 10-2014-7024479”, dated Jul. 22, 2019, 18 Pages.

“Office Action Issued In Korean Patent Application No. 10-2014-7024479”, dated Jan. 30, 2020, 10 Pages.

“Notice of Allowance Issued in Korean Patent Application No. 10-2014-7024487”, dated Feb. 10, 2020, 5 Pages.

“Office Action Issued in Korean Patent Application No. 10-2014-7024487”, dated Aug. 7, 2019, 10 pages.

“Office Action Issued in Korean Patent Application No. 10-2014-7024500”, dated Aug. 7, 2019, 15 Pages.

“Office Action Issued in Korean Patent Application No. 10-2014-7024552”, dated Aug. 7, 2019, 14 Pages.

“Office Action Issued In Korean Patent Application No. 10-2014-7024555”, dated Jul. 22, 2019, 14 Pages.

“Office Action Issued In Korean Patent Application No. 10-2014-7024555”, dated Jan. 20, 2020, 10 Pages.

“Office Action Issued in Korean Patent Application No. 10-2014-7024564”, dated Jan. 9, 2020, 10 Pages.

“Office Action Issued in Korean Patent Application No. 10-2014-7024564”, dated Jul. 25, 2019, 9 Pages.

“Office Action Issued in European Patent Application No. 13758583.2”, dated Sep. 26, 2019, 6 Pages.

“Summons to Attend Oral Proceedings Issued in European Patent Application No. 13857958.6”, dated Aug. 2, 2019, 9 Pages.

“Office Action Issued in European Patent Application No. 13859280.3”, dated Aug. 23, 2019, 5 Pages.

“Final Office Action Issued in U.S. Appl. No. 15/083,008”, dated Jan. 16, 2020, 14 Pages.

“Non Final Office Action Issued in U.S. Appl. No. 15/083,008”, dated Feb. 28, 2020, 14 Pages.

“Non Final Office Action Issued In U.S. Appl. No. 15/083,008”, dated Jul. 19, 2019, 15 Pages.

“Office Action Issued in European Patent Application No. 18157310.6”, dated Apr. 6, 2020, 5 Pages.

“Office Action Issued in European Patent Application No. 19164804.7”, dated Jun. 21, 2019, 8 Pages.

“Extended European Search Report Issued in European Patent Application No. 20192228.3”, dated Dec. 1, 2020, 8 Pages.

“Office Action Issued in Indian Patent Application No. 5767/CHENP/2015”, dated Jun. 25, 2020, 6 Pages.

“Non Final Office Action Issued in U.S. Appl. No. 13/471,393”, dated Jun. 24, 2021, 25 Pages.

“Final Office Action Issued in U.S. Appl. No. 13/471,393”, dated Mar. 8, 2021, 24 Pages.

“Office Action Issued in European Patent Application No. 13859280.3”, dated Jan. 15, 2021, 5 Pages.

“Office Action Issued in European Patent Application No. 19164804.7”, dated Feb. 2, 2021, 4 Pages.

“Corrected Notice of Allowance”, U.S. Appl. No. 13/651,327, (Sep. 12, 2013), 2 pages.

“Corrected Notice of Allowance”, U.S. Appl. No. 13/651,327, (Sep. 23, 2013), 2 pages.

“Corrected Notice of Allowance”, U.S. Appl. No. 13/651,726, (Sep. 17, 2013), 2 pages.

“Final Office Action”, U.S. Appl. No. 13/471,001, (Jul. 25, 2013), 20 pages.

“Final Office Action”, U.S. Appl. No. 13/471,139, (Sep. 16, 2013), 13 pages.

“Final Office Action”, U.S. Appl. No. 13/471,336, (Aug. 28, 2013), 18 pages.

“Final Office Action”, U.S. Appl. No. 13/651,976, (Jul. 25, 2013), 21 pages.

“Final Office Action”, U.S. Appl. No. 13/653,321, (Aug. 2, 2013), 17 pages.

“Non-Final Office Action”, U.S. Appl. No. 13/527,263, (Jul. 19, 2013), 5 pages.

“Non-Final Office Action”, U.S. Appl. No. 13/938,930, (Aug. 29, 2013), 9 pages.

“Non-Final Office Action”, U.S. Appl. No. 13/939,002, (Aug. 28, 2013), 6 pages.

“Non-Final Office Action”, U.S. Appl. No. 13/939,032, (Aug. 29, 2013), 7 pages.

“PCT Search Report and Written Opinion”, Application No. PCT/US2013/029461, (Jun. 21, 2013), 11 pages.

“PCT Search Report and Written Opinion”, Application No. PCT/US2013/028948, (Jun. 21, 2013), 11 pages.

“Corrected Notice of Allowance”, U.S. Appl. No. 13/471,030, Sep. 30, 2014, 2 pages.

“Corrected Notice of Allowance”, U.S. Appl. No. 14/199,924, Sep. 19, 2014, 2 pages.

“Final Office Action”, U.S. Appl. No. 13/471,336, Oct. 6, 2014, 13 pages.

“Final Office Action”, U.S. Appl. No. 14/200,595, Nov. 19, 2014, 5 pages.

“International Search Report and Written Opinion”, Application No. PCT/US2014/043546, Oct. 9, 2014, 10 pages.

“Non-Final Office Action”, U.S. Appl. No. 13/780,228, Sep. 15, 2014, 18 pages.

“Notice of Allowance”, U.S. Appl. No. 14/277,240, Sep. 16, 2014, 4 pages.

“Non-Final Office Action”, U.S. Appl. No. 14/063,912, Jan. 2, 2014, 10 pages.

“Non-Final Office Action”, U.S. Appl. No. 13/603,918, Dec. 19, 2013, 12 pages.

“FingerWorks Installation and Operation Guide for the TouchStream ST and TouchStream LP”, FingerWorks, Inc. Retrieved from <<http://ec1.images-amazon.com/media/i3d/01/A/man-migrate/MANUAL000049862.pdf>>, 2002, 14 pages.

“Non-Final Office Action”, U.S. Appl. No. 13/651,232, Dec. 5, 2013, 15 pages.

“Non-Final Office Action”, U.S. Appl. No. 13/468,918, Dec. 26, 2013, 18 pages.

“Corrected Notice of Allowance”, U.S. Appl. No. 13/563,435, Jan. 14, 2014, 2 pages.

“Corrected Notice of Allowance”, U.S. Appl. No. 13/563,435, Jan. 22, 2014, 2 pages.

“Notice to Grant”, CN Application No. 201320097124.7, Oct. 8, 2013, 2 pages.

“Notice of Allowance”, U.S. Appl. No. 13/653,321, Dec. 18, 2013, 4 pages.

“Foreign Office Action”, CN Application No. 201320097066.8, Oct. 24, 2013, 5 Pages.

“Non-Final Office Action”, U.S. Appl. No. 13/939,002, Dec. 20, 2013, 5 pages.

(56)

References Cited

OTHER PUBLICATIONS

- “Final Office Action”, U.S. Appl. No. 13/939,032, Dec. 20, 2013, 5 pages.
- “Restriction Requirement”, U.S. Appl. No. 13/468,918, Nov. 29, 2013, 6 pages.
- “Restriction Requirement”, U.S. Appl. No. 13/715,133, Dec. 3, 2013, 6 pages.
- “Notice of Allowance”, U.S. Appl. No. 13/565,124, Dec. 24, 2013, 6 pages.
- “Notice of Allowance”, U.S. Appl. No. 13/715,133, Jan. 6, 2014, 7 pages.
- “Restriction Requirement”, U.S. Appl. No. 13/603,918, Nov. 27, 2013, 8 pages.
- Ramirez, “Applying Solventless Elastomeric Polyurethanes on Concrete in Wastewater Service”, In Proceedings: Journal of Protective Coatings and Linings, May 1995, 13 pages.
- “Corrected Notice of Allowance”, U.S. Appl. No. 14/277,240, Jan. 8, 2015, 2 pages.
- “Final Office Action”, U.S. Appl. No. 14/225,276, Dec. 17, 2014, 6 pages.
- “First Examination Report”, NZ Application No. 628690, Nov. 27, 2014, 2 pages.
- “Non-Final Office Action”, U.S. Appl. No. 13/471,030, Jan. 15, 2015, 7 pages.
- “Non-Final Office Action”, U.S. Appl. No. 14/147,252, Feb. 23, 2015, 11 pages.
- “Notice of Allowance”, U.S. Appl. No. 13/651,976, Jan. 21, 2015, 10 pages.
- “Notice of Allowance”, U.S. Appl. No. 14/200,595, Feb. 17, 2015, 2 pages.
- “Restriction Requirement”, U.S. Appl. No. 14/147,252, Dec. 1, 2014, 6 pages.
- “Supplemental Notice of Allowance”, U.S. Appl. No. 13/471,405, Dec. 17, 2014, 5 pages.
- “Advisory Action”, U.S. Appl. No. 13/939,032, Feb. 24, 2014, 2 pages.
- “Notice of Allowance”, U.S. Appl. No. 13/938,930, Feb. 20, 2014, 4 pages.
- “Notice of Allowance”, U.S. Appl. No. 13/939,002, Mar. 3, 2014, 4 pages.
- “Notice of Allowance”, U.S. Appl. No. 13/471,139, Mar. 17, 2014, 4 pages.
- “Corrected Notice of Allowance”, U.S. Appl. No. 13/651,232, Apr. 24, 2015, 2 pages.
- “Corrected Notice of Allowance”, U.S. Appl. No. 13/656,055, Apr. 13, 2015, 2 pages.
- “Corrected Notice of Allowance”, U.S. Appl. No. 13/715,229, Apr. 16, 2015, 2 pages.
- “Corrected Notice of Allowance”, U.S. Appl. No. 14/177,018, Mar. 2, 2015, 2 pages.
- “Ex Parte Quayle Action”, U.S. Appl. No. 13/599,763, Nov. 14, 2014, 6 pages.
- “Final Office Action”, U.S. Appl. No. 13/468,949, Oct. 6, 2014, 11 pages.
- “Final Office Action”, U.S. Appl. No. 13/471,054, Oct. 23, 2014, 17 pages.
- “Final Office Action”, U.S. Appl. No. 13/471,412, Dec. 15, 2014, 11 pages.
- “Final Office Action”, U.S. Appl. No. 13/492,232, Nov. 17, 2014, 13 pages.
- “Final Office Action”, U.S. Appl. No. 13/595,700, Oct. 9, 2014, 8 pages.
- “Final Office Action”, U.S. Appl. No. 13/647,479, Dec. 12, 2014, 12 pages.
- “Final Office Action”, U.S. Appl. No. 13/655,065, Apr. 2, 2015, 23 pages.
- “Final Office Action”, U.S. Appl. No. 13/656,055, Sep. 17, 2014, 10 pages.
- “Final Office Action”, U.S. Appl. No. 13/780,228, Apr. 10, 2015, 19 pages.
- “Final Office Action”, U.S. Appl. No. 13/974,994, Oct. 6, 2014, 26 pages.
- “Final Office Action”, U.S. Appl. No. 13/975,087, Sep. 10, 2014, 19 pages.
- “Final Office Action”, U.S. Appl. No. 14/225,250, Mar. 13, 2015, 7 pages.
- “Foreign Notice on Reexamination”, CN Application No. 201320097066.8, Apr. 3, 2015, 7 Pages.
- “Foreign Office Action”, CN Application No. 201320097079.5, Jul. 28, 2014, 4 pages.
- “neXus Charging Cradle”, Retrieved from <<http://www.gen-xtech.com/neXus.php>> on Jul. 28, 2014, Apr. 17, 2012, 2 pages.
- “Non-Final Office Action”, U.S. Appl. No. 13/471,054, Mar. 13, 2015, 18 pages.
- “Non-Final Office Action”, U.S. Appl. No. 13/471,376, Mar. 27, 2015, 28 pages.
- “Non-Final Office Action”, U.S. Appl. No. 13/471,393, Mar. 26, 2015, 13 pages.
- “Non-Final Office Action”, U.S. Appl. No. 13/471,393, Oct. 20, 2014, 12 pages.
- “Non-Final Office Action”, U.S. Appl. No. 13/492,232, Feb. 24, 2015, 12 pages.
- “Non-Final Office Action”, U.S. Appl. No. 13/525,614, Nov. 24, 2014, 19 pages.
- “Non-Final Office Action”, U.S. Appl. No. 13/653,184, Dec. 1, 2014, 7 pages.
- “Non-Final Office Action”, U.S. Appl. No. 13/653,218, Mar. 4, 2015, 16 pages.
- “Non-Final Office Action”, U.S. Appl. No. 13/655,065, Dec. 19, 2014, 24 pages.
- “Non-Final Office Action”, U.S. Appl. No. 13/852,848, Mar. 26, 2015, 7 pages.
- “Non-Final Office Action”, U.S. Appl. No. 13/974,994, Jan. 23, 2015, 26 pages.
- “Non-Final Office Action”, U.S. Appl. No. 13/975,087, Feb. 27, 2015, 20 pages.
- “Non-Final Office Action”, U.S. Appl. No. 14/059,280, Mar. 3, 2015, 18 pages.
- “Non-Final Office Action”, U.S. Appl. No. 14/225,276, Apr. 23, 2015, 7 pages.
- “Notice of Allowance”, U.S. Appl. No. 13/468,949, Apr. 24, 2015, 9 pages.
- “Notice of Allowance”, U.S. Appl. No. 13/468,918, Apr. 8, 2015, 7 pages.
- “Notice of Allowance”, U.S. Appl. No. 13/471,030, Apr. 6, 2015, 6 pages.
- “Notice of Allowance”, U.S. Appl. No. 13/599,763, Feb. 18, 2015, 4 pages.
- “Notice of Allowance”, U.S. Appl. No. 13/603,918, Jan. 22, 2015, 8 pages.
- “Notice of Allowance”, U.S. Appl. No. 13/651,232, Mar. 30, 2015, 7 pages.
- “Notice of Allowance”, U.S. Appl. No. 13/653,184, Mar. 10, 2015, 6 pages.
- “Notice of Allowance”, U.S. Appl. No. 13/653,682, Sep. 24, 2014, 4 pages.
- “Notice of Allowance”, U.S. Appl. No. 13/656,055, Mar. 4, 2015, 7 pages.
- “Notice of Allowance”, U.S. Appl. No. 13/666,958, Aug. 29, 2014, 9 pages.
- “Notice of Allowance”, U.S. Appl. No. 13/715,229, Jan. 9, 2015, 6 pages.
- “Notice of Allowance”, U.S. Appl. No. 14/177,018, Nov. 21, 2014, 7 pages.
- “Notice of Allowance”, U.S. Appl. No. 14/200,595, Feb. 25, 2015, 4 pages.
- “Rechargeable Stylus Pen”, Retrieved from <<http://www.e-pens.com/uk/rechargeable-stylus-pen.html>> on Jul. 28, 2014, Jul. 5, 2013, 1 pages.
- “Restriction Requirement”, U.S. Appl. No. 13/653,218, Nov. 7, 2014, 6 pages.
- “Snugg iPad 3 Keyboard Case—Cover Ultra Slim Bluetooth Keyboard Case for the iPad 3 & iPad 2”, Retrieved from <<https://web>

(56)

References Cited

OTHER PUBLICATIONS

archive.org/web/20120810202056/http://www.amazon.com/Snugg-iPad-Keyboard-Case-Bluetooth/dp/B008CCHXJE> on Jan. 23, 2015, Aug. 10, 2012, 4 pages.

“Supplemental Notice of Allowance”, U.S. Appl. No. 13/595,700, Apr. 10, 2015, 2 pages.

“Supplemental Notice of Allowance”, U.S. Appl. No. 13/603,918, Apr. 20, 2015, 8 pages.

“Writer 1 for iPad 1 keyboard + Case (Aluminum Bluetooth Keyboard, Quick Eject and Easy Angle Function!)”, Retrieved from <https://web.archive.org/web/20120817053825/http://www.amazon.com/keyboard-Aluminum-Bluetooth-Keyboard-Function/dp/B004OQLSLG> on Jan. 23, 2015, Aug. 17, 2012, 5 pages.

Harrison, “UIST 2009 Student Innovation Contest—Demo Video”, Retrieved From: <https://www.youtube.com/watch?v=PDI8eYIASf0> Sep. 16, 2014, Jul. 23, 2009, 1 pages.

Schafer, “Using Interactive Maps for Navigation and Collaboration”, CHI ’01 Extended Abstracts on Human Factors in Computing Systems, Mar. 31, 2001, 2 pages.

Van “Lenovo Thinkpad Tablet 2 Review”, Retrieved from: <http://www.digitaltrends.com/tablet-reviews/lenovo-thinkpad-tablet-2-review/> Jan. 29, 2014, Feb. 12, 2013, 7 Pages.

“Accessing Device Sensors”, retrieved from <https://developer.palm.com/content/api/dev-guide/pdk/accessing-device-sensors.html> on May 25, 2012, 4 pages.

“ACPI Docking for Windows Operating Systems”, Retrieved from: <http://www.scribube.com/limba/engleza/software/ACPI-Docking-for-Windows-Opera331824193.php> on Jul. 6, 2012, 10 pages.

“Cholesteric Liquid Crystal”, Retrieved from: <http://en.wikipedia.org/wiki/Cholesteric_liquid_crystal> on Aug. 6, 2012,(Jun. 10, 2012), 2 pages.

“Cirago Slim Case®—Protective case with built-in kickstand for your iPhone 5®”, Retrieved from <http://cirago.com/wordpress/wp-content/uploads/2012/10/ipc1500brochure1.pdf> on Jan. 29, 2013, (Jan. 2013), 1 page.

“Corrected Notice of Allowance”, U.S. Appl. No. 13/470,633, (Apr. 9, 2013), 2 pages.

“Corrected Notice of Allowance”, U.S. Appl. No. 13/470,633, (Jul. 2, 2013), 2 pages.

“Developing Next-Generation Human Interfaces using Capacitive and Infrared Proximity Sensing”, *Silicon Laboratories, Inc.*, Available at <http://www.silabs.com/pages/DownloadDoc.aspx?FILEURL=%support%20documents/technicaldocs/capacitive%20and%20proximity%20sensing_wp.pdf&src=SearchResults>,(Aug. 30, 2010), pp. 1-10.

“Directional Backlighting for Display Panels”, U.S. Appl. No. 13/021,448, (Feb. 4, 2011), 38 pages.

“DR2PA”, retrieved from <http://www.architainment.co.uk/wp-content/uploads/2012/08/DR2PA-AU-US-size-Data-Sheet-Rev-H_LOGO.pdf> on Sep. 17, 2012, 4 pages.

“Final Office Action”, U.S. Appl. No. 13/651,195, (Apr. 18, 2013), 13 pages.

“Final Office Action”, U.S. Appl. No. 13/651,232, (May 21, 2013), 21 pages.

“Final Office Action”, U.S. Appl. No. 13/651,287, (May 3, 2013), 16 pages.

“First One Handed Fabric Keyboard with Bluetooth Wireless Technology”, Retrieved from: <http://press.xtvworld.com/article3817.html> on May 8, 2012,(Jan. 6, 2005), 2 pages.

“Force and Position Sensing Resistors: An Emerging Technology”, *Interlink Electronics*, Available at <http://staff.science.uva.nl/~vlaander/docu/FSR/An_Exploring_Technology.pdf>,(Feb. 1990), pp. 1-6.

“Frogpad Introduces Wearable Fabric Keyboard with Bluetooth Technology”, Retrieved from: <http://www.geekzone.co.nz/content.asp?contentid=3898> on May 7, 2012,(Jan. 7, 2005), 3 pages.

“How to Use the iPad’s Onscreen Keyboard”, Retrieved from <http://www.dummies.com/how-to/content/how-to-use-the-ipads-onscreen-keyboard.html> on Aug. 28, 2012, 3 pages.

“i-Interactor electronic pen”, Retrieved from: <http://www.alibaba.com/product-gs/331004878/i_Interactor_electronic_pen.html> on Jun. 19, 2012, 5 pages.

“Incipio LG G-Slate Premium Kickstand Case—Black Nylon”, Retrieved from: <http://www.amazon.com/Incipio-G-Slate-Premium-Kickstand-Case/dp/B004ZKP916> on May 8, 2012, 4 pages.

“Membrane Keyboards & Membrane Keypads”, Retrieved from: <http://www.pannam.com/> on May 9, 2012,(Mar. 4, 2009), 2 pages.

“Motion Sensors”, *Android Developers*, retrieved from <http://developer.android.com/guide/topics/sensors/sensors_motion.html> May 25, 2012, 7 pages.

“MPC Fly Music Production Controller”, *AKAI Professional*, <http://www.akairompc.com/mpc-fly> on Jul. 9, 2012, 4 pages.

“NI Releases New Maschine & Maschine Mikro”, Retrieved from <http://www.djbooth.net/index/dj-equipment/entry/ni-releases-new-maschine-mikro/> on Sep. 17, 2012, 19 pages.

“Non-Final Office Action”, U.S. Appl. No. 13/021,448, (Dec. 13, 2012), 9 pages.

“Non-Final Office Action”, U.S. Appl. No. 13/471,001, (Feb. 19, 2013), 15 pages.

“Non-Final Office Action”, U.S. Appl. No. 13/471,139, (Mar. 21, 2013), 12 pages.

“Non-Final Office Action”, U.S. Appl. No. 13/471,202, (Feb. 11, 2013), 10 pages.

“Non-Final Office Action”, U.S. Appl. No. 13/471,336, (Jan. 18, 2013), 14 pages.

“Non-Final Office Action”, U.S. Appl. No. 13/563,435, (Jun. 14, 2013), 6 pages.

“Non-Final Office Action”, U.S. Appl. No. 13/564,520, (Jun. 19, 2013), 8 pages.

“Non-Final Office Action”, U.S. Appl. No. 13/565,124, (Jun. 17, 2013), 5 pages.

“Non-Final Office Action”, U.S. Appl. No. 13/651,195, (Jan. 2, 2013), 14 pages.

“Non-Final Office Action”, U.S. Appl. No. 13/651,232, (Jan. 17, 2013), 15 pages.

“Non-Final Office Action”, U.S. Appl. No. 13/651,272, (Feb. 12, 2013), 10 pages.

“Non-Final Office Action”, U.S. Appl. No. 13/651,287, (Jan. 29, 2013), 13 pages.

“Non-Final Office Action”, U.S. Appl. No. 13/651,304, (Mar. 22, 2013), 9 pages.

“Non-Final Office Action”, U.S. Appl. No. 13/651,327, (Mar. 22, 2013), 6 pages.

“Non-Final Office Action”, U.S. Appl. No. 13/651,726, (Apr. 15, 2013), 6 pages.

“Non-Final Office Action”, U.S. Appl. No. 13/651,871, (Mar. 18, 2013), 14 pages.

“Non-Final Office Action”, U.S. Appl. No. 13/651 871 (Jul. 1, 2013), 5 pages.

“Non-Final Office Action”, U.S. Appl. No. 13/651,976, (Feb. 22, 2013), 16 pages.

“Non-Final Office Action”, U.S. Appl. No. 13/653,321, (Feb. 1, 2013), 13 pages.

“Non-Final Office Action”, U.S. Appl. No. 13/653,682, (Feb. 7, 2013), 11 pages.

“Non-Final Office Action”, U.S. Appl. No. 13/653,682, (Jun. 3, 2013), 14 pages.

“Non-Final Office Action”, U.S. Appl. No. 13/656,055, (Apr. 23, 2013), 11 pages.

“Non-Final Office Action”, U.S. Appl. No. 13/656,520, (Feb. 1, 2013), 15 pages.

“Non-Final Office Action”, U.S. Appl. No. 13/656,520, (Jun. 5, 2013), 8 pages.

“Notice of Allowance”, U.S. Appl. No. 13/470,633, (Mar. 22, 2013), 7 pages.

“Notice of Allowance”, U.S. Appl. No. 13/471,202, (May 28, 2013), 7 pages.

“Notice of Allowance”, U.S. Appl. No. 13/651,195, (Jul. 8, 2013), 9 pages.

“Notice of Allowance”, U.S. Appl. No. 13/651,272, (May 2, 2013), 7 pages.

(56)

References Cited

OTHER PUBLICATIONS

- “Notice of Allowance”, U.S. Appl. No. 13/651,304, (Jul. 1, 2013), 5 pages.
- “Notice of Allowance”, U.S. Appl. No. 13/651,327, (Jun. 11, 2013), 7 pages.
- “Notice of Allowance”, U.S. Appl. No. 13/651,726, (May 31, 2013), 5 pages.
- “On-Screen Keyboard for Windows 7, Vista, XP with Touchscreen”, Retrieved from <www.comfort-software.com/on-screen-keyboard.html> on Aug. 28, 2012, Feb. 2, 2011, 3 pages.
- “Optical Sensors in Smart Mobile Devices”, *ON Semiconductor*, TND415/D, Available at <http://www.onsemi.jp/pub_link/Collateral/TND415-D.PDF>, (Nov. 2010), pp. 1-13.
- “Optics for Displays: Waveguide-based Wedge Creates Collimated Display Backlight”, *OptoIQ*, retrieved from <http://www.optoIQ.com/index/photronics-technologies-applications/lfw-display/lfw-article-display-articles.laser-focus-world.volume-46.issue-1.world-news.optics-for_displays.html> on Nov. 2, 2010, (Jan. 1, 2010), 3 pages.
- “Position Sensors”, *Android Developers*, <http://developer.android.com/guide/topics/sensors/sensors_position.html> May 25, 2012, 5 pages.
- “Reflex LCD Writing Tablets”, retrieved from <<http://www.kentdisplays.com/products/lcdwritingtablets.html>> on Jun. 27, 2012, 3 pages.
- “Restriction Requirement”, U.S. Appl. No. 13/471,139, (Jan. 17, 2013), 7 pages.
- “Restriction Requirement”, U.S. Appl. No. 13/651,304, (Jan. 18, 2013), 7 pages.
- “Restriction Requirement”, U.S. Appl. No. 13/651,726, (Feb. 22, 2013), 6 pages.
- “Restriction Requirement”, U.S. Appl. No. 13/651,871, (Feb. 7, 2013), 6 pages.
- “SMART Board™ Interactive Display Frame Pencil Pack”, Available at <[http://downloads01.smarttech.com/media/sitecore/en/support/product/sbfpd/400series\(interactivedisplayframes\)/guides/smartboardinteractivedisplayframepencilpackv12mar09.pdf](http://downloads01.smarttech.com/media/sitecore/en/support/product/sbfpd/400series(interactivedisplayframes)/guides/smartboardinteractivedisplayframepencilpackv12mar09.pdf)>, (2009), 2 pages.
- “SolRx™ E-Series Multidirectional Phototherapy Expandable™ 2-Bulb Full Body Panel System”, Retrieved from: <http://www.solarcsystems.com/us_multidirectional_uv_light_therapy_1_intro.html> on Jul. 25, 2012, (2011), 4 pages.
- “The Microsoft Surface Tablets Comes With Impressive Design and Specs”, Retrieved from <<http://microsofttabletreview.com/the-microsoft-surface-tablets-comes-with-impressive-design-and-specs>> on Jan. 30, 2013, (Jun. 2012), 2 pages.
- “Tilt Shift Lenses: Perspective Control”, retrieved from <http://www.cambridgeincolour.com/tutorials/tilt-shift-lenses1.htm>, (Mar. 28, 2008), 11 Pages.
- “Virtualization Getting Started Guide”, *Red Hat Enterprise Linux 6, Edition 0.2*, retrieved from <http://docs.redhat.com/docs/en-US/Red_Hat_Enterprise_Linux/6/html-single/Virtualization_Getting_Started_Guide/index.html> on Jun. 13, 2012, 24 pages.
- “What is Active Alignment?”, http://www.kasalis.com/active_alignment.html, retrieved on Nov. 22, 2012, 2 Pages.
- Block, Steve et al., “DeviceOrientation Event Specification”, *W3C, Editor’s Draft*, retrieved from <<https://developer.palm.com/content/api/dev-guide/pdk/accessing-device-sensors.html>> May 25, 2012, (Jul. 12, 2011), 14 pages.
- Brown, Rich “Microsoft Shows Off Pressure-Sensitive Keyboard”, retrieved from <http://news.cnet.com/8301-17938_105-10304792-1.html> on May 7, 2012, (Aug. 6, 2009), 2 pages.
- Butler, Alex et al., “SideSight: Multi-“touch” Interaction around Small Devices”, *In the proceedings of the 21st annual ACM Symposium on User interface software and technology.*, retrieved from <http://research.microsoft.com/pubs/132534/sidesight_crv3.pdf> May 29, 2012, (Oct. 19, 2008), 4 pages.
- Crider, Michael “Sony Slate Concept Tablet “Grows” a Kickstand”, Retrieved from: <<http://androidcommunity.com/sony-slate-concept-tablet-grows-a-kickstand-20120116/>> on May 4, 2012, (Jan. 16, 2012), 9 pages.
- Das, Apurba et al., “Study of Heat Transfer through Multilayer Clothing Assemblies: A Theoretical Prediction”, Retrieved from http://www.autexrj.com/cms/zalaczone_pliki/5_013_11.pdf, (Jun. 2011), 7 pages.
- Dietz, Paul H., et al., “A Practical Pressure Sensitive Computer Keyboard”, In Proceedings of UIST 2009, (Oct. 2009), 4 pages.
- Gaver, William W., et al., “A Virtual Window on Media Space”, retrieved from <<http://www.gold.ac.uk/media/15gaver-smets-overbeeke.MediaSpaceWindow.chi95.pdf>> on Jun. 1, 2012, retrieved from <<http://www.gold.ac.uk/media/15gaver-smets-overbeeke.MediaSpaceWindow.chi95.pdf>> on Jun. 1, 2012, (May 7, 1995), 9 pages.
- Glatt, Jeff “Channel and Key Pressure (Aftertouch).”, Retrieved from: <<http://home.roadrunner.com/~jgglatt/tutr/touch.htm>> on Jun. 11, 2012, 2 pages.
- Hanlon, Mike “ElekTex Smart Fabric Keyboard Goes Wireless”, Retrieved from: <<http://www.gizmag.com/go/5048/>> on May 7, 2012, (Jan. 15, 2006), 5 pages.
- Harada, Susumu et al., “VoiceDraw: A Hands-Free Voice-Driven Drawing Application for People With Motor Impairments”, *In Proceedings of Ninth International ACM SIGACCESS Conference on Computers and Accessibility*, retrieved from <<http://citeseerx.ist.psu.edu/viewdoc/download?doi=10.1.1.113.7211&rep=rep1&type=pdf>> on Jun. 1, 2012, (Oct. 15, 2007), 8 pages.
- Iwase, Eiji “Multistep Sequential Batch Assembly of Three-Dimensional Ferromagnetic Microstructures with Elastic Hinges”, Retrieved at <<http://ieeexplore.ieee.org/stamp/stamp.jsp?tp=&arnumber=1549861>> *Proceedings: Journal of Microelectromechanical Systems*, (Dec. 2005), 7 pages.
- Kaufmann, Benoit et al., “Hand Posture Recognition Using Real-time Artificial Evolution”, *EvoApplications’09*, retrieved from <<http://evelyne.lutton.free.fr/Papers/KaufmannEvolASP2010.pdf>> on Jan. 5, 2012, (Apr. 3, 2010), 10 pages.
- Kaur, Sukhmani “Vincent Liew’s redesigned laptop satisfies ergonomic needs”, Retrieved from: <<http://www.designbuzz.com/entry/vincent-liew-s-redesigned-laptop-satisfies-ergonomic-needs/>> on Jul. 27, 2012, (Jun. 21, 2010), 4 pages.
- Khuntontong, Puttachat et al., “Fabrication of Molded Interconnection Devices by Ultrasonic Hot Embossing on Thin Polymer Films”, *IEEE Transactions on Electronics Packaging Manufacturing*, vol. 32, No. 3, (Jul. 2009), pp. 152-156.
- Li, et al., “Characteristic Mode Based Tradeoff Analysis of Antenna-Chassis Interactions for Multiple Antenna Terminals”, *In IEEE Transactions on Antennas and Propagation*, <<http://ieeexplore.ieee.org/stamp/stamp.jsp?tp=&arnumber=6060882>>, (Feb. 2012), 13 pages.
- Linderholm, Owen “Logitech Shows Cloth Keyboard for PDAs”, Retrieved from: <<http://www.pcworld.com/article/89084/logitech-shows-cloth-keyboard-for-pdas.html>> on May 7, 2012, (Mar. 15, 2002), 5 pages.
- Manresa-Yee, Cristina et al., “Experiences Using a Hands-Free Interface”, *In Proceedings of the 10th International ACM SIGACCESS Conference on Computers and Accessibility*, retrieved from <<http://dmi.uib.es/~cmanresay/Research/%5BMan08%.pdf>> Jun. 1, 2012, (Oct. 13, 2008), pp. 261-262.
- McLellan, Charles “ElekSen Wireless Fabric Keyboard: a first look”, Retrieved from: <<http://www.zdnetasia.com/elek-sen-wireless-fabric-keyboard-a-first-look-40278954.htm>> on May 7, 2012, (Jul. 17, 2006), 9 pages.
- Nakanishi, Hideyuki et al., “Movable Cameras Enhance Social Telepresence in Media Spaces”, *In Proceedings of the 27th International Conference on Human Factors in Computing Systems*, retrieved from <http://smg.ams.eng.osaka-u.ac.jp/~nakanishi/hnp_2009_chi.pdf> on Jun. 1, 2012, (Apr. 6, 2009), 10 pages.
- Piltch, Avram “ASUS Eee Pad Slider SL 101 Review”, Retrieved from <<http://www.laptopmag.com/review/tablets/asus-eee-pad-slider-sl101.aspx>>, Sep. 22, 2011, 5 pages.
- Post, E.R. et al., “E-Broidery: Design and Fabrication of Textile-Based Computing”, *IBM Systems Journal*, vol. 39, Issue 3 & 4, (Jul. 2000), pp. 840-860.

(56)

References Cited

OTHER PUBLICATIONS

- Purcher, Jack "Apple is Paving the Way for a New 3D GUI for IOS Devices", Retrieved from: <<http://www.patentlyapple.com/patently-apple/2012/01/apple-is-paving-the-way-for-a-new-3d-gui-for-ios-devices.html>> on Jun. 4, 2012,(Jan. 12, 2012), 15 pages.
- Qin, Yongqiang et al., "pPen: Enabling Authenticated Pen and Touch Interaction on Tabletop Surfaces", In *Proceedings of ITS 2010*, Available<<http://www.dfki.de/its2010/papers/pdf/po172.pdf>>,(Nov. 2010), pp. 283-284.
- Reilink, Rob et al., "Endoscopic Camera Control by Head Movements for Thoracic Surgery", In *Proceedings of 3rd IEEE RAS & EMBS International Conference of Biomedical Robotics and Biomechatronics*, retrieved from <http://doc.utwente.nl/74929/1/biorob_online.pdf> on Jun. 1, 2012,(Sep. 26, 2010), pp. 510-515.
- Sumimoto, Mark "Touch & Write: Surface Computing With Touch and Pen Input", Retrieved from: <<http://www.gottabemobile.com/2009/08/07/touch-write-surface-computing-with-touch-and-pen-input/>> on Jun. 19, 2012,(Aug. 7, 2009), 4 pages.
- Sundstedt, Veronica "Gazing at Games: Using Eye Tracking to control Virtual Characters", In *ACM SIGGRAPH 2010 Courses*, retrieved from <http://www.tobii.com/Global/Analysis/Training/EyeTrackAwards/veronica_sundstedt.pdf> Jun. 1, 2012,(Jul. 28, 2010), 85 pages.
- Takamatsu, Seiichi et al., "Flexible Fabric Keyboard with Conductive Polymer-Coated Fibers", In *Proceedings of Sensors 2011*,(Oct. 28, 2011), 4 pages.
- Travis, Adrian et al., "Collimated Light from a Waveguide for a Display Backlight", *Optics Express*, 19714, vol. 17, No. 22, retrieved from <<http://download.microsoft.com/download/D/2/E/D2E425F8-CF3C-4C71-A4A2-70F9D4081007/OpticsExpressbacklightpaper.pdf>> on Oct. 15, 2009, 6 pages.
- Travis, Adrian et al., "The Design of Backlights for View-Sequential 3D", retrieved from <<http://download.microsoft.com/download/D/2/E/D2E425F8-CF3C-4C71-A4A2-70F9D4081007/Backlightforviewsequentialautostereo.docx>> on Nov. 1, 2010, 4 pages.
- Valli, Alessandro "Notes on Natural Interaction", retrieved from <<http://www.idemployee.id.tue.nl/g.w.m.rauterberg/lecturenotes/valli-2004.pdf>> on Jan. 5, 2012,(Sep. 2005), 80 pages.
- Valliath, G T., "Design of Hologram for Brightness Enhancement in Color LCDs", Retrieved from <http://www.loreti.it/Download/PDF/LCD/44_05.pdf> on Sep. 17, 2012, 5 pages.
- Vaucelle, Cati "Scopemate, A Robotic Microscope!", *Architectradure*, retrieved from <<http://architectradure.blogspot.com/2011/10/at-uis-this-monday-scopemate-robotic.html>> on Jun. 6, 2012,(Oct. 17, 2011), 2 pages.
- Williams, Jim "A Fourth Generation of LCD Backlight Technology", Retrieved from <<http://cds.linear.com/docs/Application%20Note/an65f.pdf>>, (Nov. 1995), 124 pages.
- Xu, Zhang et al., "Hand Gesture Recognition and Virtual Game Control Based on 3D Accelerometer and EMG Sensors", *IUI'09*, Feb. 8-11, 2009, retrieved from <<http://sclab.yonsei.ac.kr/courses/10TPR/10TPR.files/Hand%20Gesture%20Recognition%20and%20Virtual%20Game%20Control%20based%20on%203d%20accelerometer%20and%20EMG%20sensors.pdf>> on Jan. 5, 2012,(Feb. 8, 2009), 5 pages.
- Xu, Zhi-Gang et al., "Vision-based Detection of Dynamic Gesture", *ICTM'09*, Dec. 5-6, 2009, retrieved from <<http://ieeexplore.ieee.org/stamp/stamp.jsp?tp=&number=5412956>> on Jan. 5, 2012,(Dec. 5, 2009), pp. 223-226.
- Zhang, et al., "Model-Based Development of Dynamically Adaptive Software", In *Proceedings of ICSE 2006*, Available at <<http://www.irisa.fr/lande/lande/icse-proceedings/icse/p371.pdf>>,(May 20, 2006), pp. 371-380.
- Zhu, Dingyun et al., "Keyboard before Head Tracking Depresses User Success in Remote Camera Control", In *Proceedings of 12th IFIP TC 13 International Conference on Human-Computer Interaction, Part II*, retrieved from <http://csiro.academia.edu/Departments/CSIRO_ICT_Centre/Papers?page=5> on Jun. 1, 2012,(Aug. 24, 2009),14 pages.
- "Corrected Notice of Allowance", U.S. Appl. No. 13/651,232, Jun. 10, 2015, 2 pages.
- "Corrected Notice of Allowance", U.S. Appl. No. 13/651,232, Jul. 6, 2015, 2 pages.
- "Corrected Notice of Allowance", U.S. Appl. No. 14/200,595, Jun. 4, 2015, 3 pages.
- "Final Office Action", U.S. Appl. No. 14/059,280, Jul. 22, 2015, 25 pages.
- "Final Office Action", U.S. Appl. No. 14/147,252, Jun. 25, 2015, 11 pages.
- "Foreign Office Action", CN Application No. 201310067335.0, Jun. 12, 2015, 15 Pages.
- "Non-Final Office Action", U.S. Appl. No. 13/471,336, Jun. 24, 2015, 15 pages.
- "Non-Final Office Action", U.S. Appl. No. 14/727,001, Jul. 10, 2015, 7 pages.
- "Notice of Allowance", U.S. Appl. No. 14/225,276, Jun. 22, 2015, 4 pages.
- "Notice of Allowance", U.S. Appl. No. 14/457,881, Jul. 22, 2015, 7 pages.
- "Supplemental Notice of Allowance", U.S. Appl. No. 13/468,918, Jun. 4, 2015, 2 pages.
- "Supplemental Notice of Allowance", U.S. Appl. No. 13/468,949, Jun. 5, 2015, 2 pages.
- Cunningham,"Software Infrastructure for Natural Language Processing", In *Proceedings of the fifth conference on Applied natural language processing*, Mar. 31, 1997, pp. 237-244.
- "Advisory Action", U.S. Appl. No. 14/059,280, Sep. 25, 2015, 7 pages.
- "Corrected Notice of Allowance", U.S. Appl. No. 13/471,030, Aug. 10, 2015, 2 pages.
- "Corrected Notice of Allowance", U.S. Appl. No. 14/225,276, Aug. 27, 2015, 2 pages.
- "Corrected Notice of Allowance", U.S. Appl. No. 14/225,276, Sep. 29, 2015, 2 pages.
- "Corrected Notice of Allowance", U.S. Appl. No. 14/457,881, Aug. 20, 2015, 2 pages.
- "Corrected Notice of Allowance", U.S. Appl. No. 14/457,881, Oct. 2, 2015, 2 pages.
- "Extended European Search Report", EP Application No. 13859280.3, Sep. 7, 2015, 6 pages.
- "Extended European Search Report", EP Application No. 13859406.4, Sep. 8, 2015, 6 pages.
- "Foreign Office Action", CN Application No. 201310067592.4, Oct. 23, 2015, 12 Pages.
- "Non-Final Office Action", U.S. Appl. No. 14/162,529, Sep. 18, 2015, 13 pages.
- "Non-Final Office Action", U.S. Appl. No. 14/225,250, Aug. 19, 2015, 9 pages.
- "Non-Final Office Action", U.S. Appl. No. 14/225,276, Aug. 19, 2015, 9 pages.
- "Notice of Allowance", U.S. Appl. No. 14/727,001, Oct. 2, 2015, 4 pages.
- "Supplemental Notice of Allowance", U.S. Appl. No. 13/468,918, Aug. 7, 2015, 4 pages.
- "Supplemental Notice of Allowance", U.S. Appl. No. 13/468,949, Sep. 14, 2015, 2 pages.
- "Advanced Configuration and Power Management Specification", *Intel Corporation, Microsoft Corporation, Toshiba Corp. Revision 1*, (Dec. 22. 1996), 364 pages.
- "Final Office Action", U.S. Appl. No. 13/653,682, (Oct. 18, 2013), 16 pages.
- "Final Office Action", U.S. Appl. No. 13/656,055, (Oct. 23, 2013), 14 pages.
- "Final Office Action", U.S. Appl. No. 13/938,930, (Nov. 8, 2013), 10 pages.
- "Final Office Action", U.S. Appl. No. 13/939,002, (Nov. 8, 2013), 7 pages.
- "International Search Report and Written Opinion", Application No. PCT/US2013/044871, (Aug. 14, 2013), 12 pages.
- "International Search Report and Written Opinion", Application No. PCT/US2013/040968, (Sep. 5, 2013), 12 pages.

(56)

References Cited

OTHER PUBLICATIONS

- “International Search Report and Written Opinion”, Application No. PCT/US2013/045049, (Sep. 16, 2013), 9 pages.
- “International Search Report and Written Opinion”, Application No. PCT/US2013/042550, (Sep. 24, 2013), 14 pages.
- “Non-Final Office Action”, U.S. Appl. No. 13/371,725, (Nov. 7, 2013), 19 pages.
- “Non-Final Office Action”, U.S. Appl. No. 13/780,228, (Oct. 30, 2013), 12 pages.
- “Notice of Allowance”, U.S. Appl. No. 13/563,435, (Nov. 12, 2013), 5 pages.
- “Notice of Allowance”, U.S. Appl. No. 13/651,871, (Oct. 2, 2013), 7 pages.
- “Notice of Allowance”, U.S. Appl. No. 13/656,520, (Oct. 2, 2013), 5 pages.
- “Notice to Grant”, CN Application No. 201320097089.9, (Sep. 29, 2013), 2 Pages.
- “Restriction Requirement”, U.S. Appl. No. 13/715,133, (Oct. 28, 2013), 6 pages.
- “Restriction Requirement”, U.S. Appl. No. 13/715,229, (Aug. 13, 2013), 7 pages.
- “Welcome to Windows 7”, Retrieved from: <<http://www.microsoft.com/en-us/download/confirmation.aspx?id=4984>> on Aug. 1, 2013, (Sep. 16, 2009), 3 pages.
- “Write & Learn Spellboard Advanced”, Available at <<http://somenmanuals.com/VTECH,WRITE%2526LEARN--SPELLBOARD--ADV--71000,J1DFHE.PDF>>, (2006), 22 pages.
- Bathiche, Steven N., et al., “Input Device with Interchangeable Surface”, U.S. Appl. No. 13/974,749, (Aug. 23, 2013), 51 pages.
- Lance, David M., et al., “Media Processing Input Device”, U.S. Appl. No. 13/655,065, filed Oct. 18, 2012, 43 pages.
- Prospero, Michael “Samsung Outs Series Hybrid PC Tablet”, Retrieved from: <http://blog.laptopmag.com/samsung-outs-series-5-hybrid-pc-tablet-running-windows-8> on Oct. 31, 2013, (Jun. 4, 2012), 7 pages.
- “Advisory Action”, U.S. Appl. No. 14/199,924, May 28, 2014, 2 pages.
- “Corrected Notice of Allowance”, U.S. Appl. No. 13/656,520, Jan. 16, 2014, 3 pages.
- “Corrected Notice of Allowance”, U.S. Appl. No. 13/715,133, Apr. 2, 2014, 2 pages.
- “Corrected Notice of Allowance”, U.S. Appl. No. 13/938,930, Jun. 6, 2014, 2 pages.
- “Corrected Notice of Allowance”, U.S. Appl. No. 13/939,002, Jun. 19, 2014, 2 pages.
- “Corrected Notice of Allowance”, U.S. Appl. No. 13/939,032, Jun. 26, 2014, 2 pages.
- “Corrected Notice of Allowance”, U.S. Appl. No. 13/939,032, Jul. 15, 2014, 2 pages.
- “Final Office Action”, U.S. Appl. No. 13/653,682, Jun. 11, 2014, 11 pages.
- “Foreign Notice of Allowance”, CN Application No. 201320096755.7, Jan. 27, 2014, 2 pages.
- “Foreign Office Action”, CN Application No. 201320097079.5, Sep. 26, 2013, 4 pages.
- “Interlink Electronics FSR (TM) Force Sensing Resistors (TM)”, Retrieved at <<http://akizukidenshi.com/download/ds/interlinkelec/94-00004+Rev+B%20FSR%20Integration%20Guide.pdf>> on Mar. 21, 2013, 36 pages.
- “International Search Report and Written Opinion”, Application No. PCT/US2014/031531, Jun. 20, 2014, 10 Pages.
- “International Search Report and Written Opinion”, Application No. PCT/US2013/065154, Feb. 5, 2014, 10 pages.
- “International Search Report and Written Opinion”, Application No. PCT/US2013/067905, Apr. 15, 2014, 9 pages.
- “Microsoft Tablet PC”, Retrieved from <http://web.archive.org/web/20120622064335/https://en.wikipedia.org/wiki/Microsoft_Tablet_PC> on Jun. 4, 2014, Jun. 21, 2012, 9 pages.
- “Non-Final Office Action”, U.S. Appl. No. 13/468,949, Jun. 20, 2014, 10 pages.
- “Non-Final Office Action”, U.S. Appl. No. 13/470,951, Jul. 2, 2014, 19 pages.
- “Non-Final Office Action”, U.S. Appl. No. 13/471,001, Jun. 17, 2014, 23 pages.
- “Non-Final Office Action”, U.S. Appl. No. 13/471,030, May 15, 2014, 10 pages.
- “Non-Final Office Action”, U.S. Appl. No. 13/471,054, Jun. 3, 2014, 15 pages.
- “Non-Final Office Action”, U.S. Appl. No. 13/564,520, Jun. 16, 2014, 5 pages.
- “Non-Final Office Action”, U.S. Appl. No. 13/595,700, Jun. 18, 2014, 8 pages.
- “Non-Final Office Action”, U.S. Appl. No. 13/599,763, May 28, 2014, 6 pages.
- “Non-Final Office Action”, U.S. Appl. No. 13/645,405, Jan. 31, 2014, 6 pages.
- “Non-Final Office Action”, U.S. Appl. No. 13/647,479, Jul. 3, 2014, 10 pages.
- “Non-Final Office Action”, U.S. Appl. No. 13/651,976, Jun. 16, 2014, 23 pages.
- “Non-Final Office Action”, U.S. Appl. No. 13/974,994, Jun. 4, 2014, 24 pages.
- “Non-Final Office Action”, U.S. Appl. No. 14/225,250, Jun. 17, 2014, 5 pages.
- “Non-Final Office Action”, U.S. Appl. No. 14/225,276, Jun. 13, 2014, 6 pages.
- “Non-Final Office Action”, U.S. Appl. No. 14/277,240, Jun. 13, 2014, 6 pages.
- “Notice of Allowance”, U.S. Appl. No. 13/468,918, Jun. 17, 2014, 5 pages.
- “Notice of Allowance”, U.S. Appl. No. 13/471,186, Jul. 3, 2014, 7 pages.
- “Notice of Allowance”, U.S. Appl. No. 13/471,405, Jun. 24, 2014, 9 pages.
- “Notice of Allowance”, U.S. Appl. No. 14/199,924, Jun. 10, 2014, 4 pages.
- “Restriction Requirement”, U.S. Appl. No. 13/595,700, May 28, 2014, 6 pages.
- “Supplemental Notice of Allowance”, U.S. Appl. No. 14/018,286, Jun. 11, 2014, 5 pages.
- “Corrected Notice of Allowance”, U.S. Appl. No. 13/563,435, Mar. 20, 2014, 2 pages.
- “Corrected Notice of Allowance”, U.S. Appl. No. 13/565,124, Apr. 3, 2014, 4 pages.
- “Corrected Notice of Allowance”, U.S. Appl. No. 13/565,124, Mar. 10, 2014, 2 pages.
- “Corrected Notice of Allowance”, U.S. Appl. No. 13/565,124, Apr. 14, 2014, 2 pages.
- “Corrected Notice of Allowance”, U.S. Appl. No. 13/938,930, May 6, 2014, 2 pages.
- “Corrected Notice of Allowance”, U.S. Appl. No. 13/939,002, May 22, 2014, 2 pages.
- “Corrected Notice of Allowance”, U.S. Appl. No. 13/939,002, May 5, 2014, 2 pages.
- “Final Office Action”, U.S. Appl. No. 13/371,725, Apr. 2, 2014, 22 pages.
- “Final Office Action”, U.S. Appl. No. 13/564,520, Jan. 15, 2014, 7 pages.
- “Final Office Action”, U.S. Appl. No. 13/603,918, Mar. 21, 2014, 14 pages.
- “Final Office Action”, U.S. Appl. No. 13/780,228, Mar. 28, 2014, 13 pages.
- “Final Office Action”, U.S. Appl. No. 14/063,912, Apr. 29, 2014, 10 pages.
- “Final Office Action”, U.S. Appl. No. 14/199,924, May 6, 2014, 5 pages.
- “Foreign Office Action”, CN Application No. 201320328022.1, Feb. 17, 2014, 4 Pages.
- “Foreign Office Action”, CN Application No. 201320328022.1, Oct. 18, 2013, 3 Pages.
- “International Search Report and Written Opinion”, Application No. PCT/US2013/045283, Mar. 12, 2014, 19 pages.

(56)

References Cited

OTHER PUBLICATIONS

- “International Search Report and Written Opinion”, Application No. PCT/US2013/044873, Nov. 22, 2013, 9 pages.
- “Non-Final Office Action”, U.S. Appl. No. 13/599,635, Feb. 25, 2014, 13 pages.
- “Non-Final Office Action”, U.S. Appl. No. 13/471,186, Feb. 27, 2014, 8 pages.
- “Non-Final Office Action”, U.S. Appl. No. 13/471,237, Mar. 24, 2014, 7 pages.
- “Non-Final Office Action”, U.S. Appl. No. 13/471,336, May 7, 2014, 17 pages.
- “Non-Final Office Action”, U.S. Appl. No. 13/471,376, Apr. 2, 2014, 17 pages.
- “Non-Final Office Action”, U.S. Appl. No. 13/471,405, Feb. 20, 2014, 37 pages.
- “Non-Final Office Action”, U.S. Appl. No. 13/492,232, Apr. 30, 2014, 9 pages.
- “Non-Final Office Action”, U.S. Appl. No. 13/527,263, Apr. 3, 2014, 6 pages.
- “Non-Final Office Action”, U.S. Appl. No. 13/564,520, Feb. 14, 2014, 5 pages.
- “Non-Final Office Action”, U.S. Appl. No. 13/653,682, Feb. 26, 2014, 10 pages.
- “Non-Final Office Action”, U.S. Appl. No. 13/655,065, Apr. 24, 2014, 16 pages.
- “Non-Final Office Action”, U.S. Appl. No. 13/656,055, Mar. 12, 2014, 17 pages.
- “Non-Final Office Action”, U.S. Appl. No. 13/975,087, May 8, 2014, 18 pages.
- “Non-Final Office Action”, U.S. Appl. No. 14/199,924, Apr. 10, 2014, 6 pages.
- “Non-Final Office Action”, U.S. Appl. No. 14/200,595, Apr. 11, 2014, 4 pages.
- “Notice of Allowance”, U.S. Appl. No. 13/471,237, May 12, 2014, 8 pages.
- “Notice of Allowance”, U.S. Appl. No. 13/651,232, Apr. 25, 2014, 9 pages.
- “Notice of Allowance”, U.S. Appl. No. 13/651,287, May 2, 2014, 6 pages.
- “Notice of Allowance”, U.S. Appl. No. 13/939,032, Apr. 3, 2014, 4 pages.
- “Notice of Allowance”, U.S. Appl. No. 14/018,286, May 23, 2014, 8 pages.
- “Supplemental Notice of Allowance”, U.S. Appl. No. 13/653,321, Mar. 28, 2014, 4 pages.
- Hinckley, et al., “Codex: A Dual Screen Tablet Computer”, Retrieved at http://www.dgp.utoronto.ca/~ravin/papers/chi2009_codex.pdf, In Proceedings of the 27th International Conference on Human Factors in Computing Systems, Apr. 9, 2009, pp. 10.
- “Basic Cam Motion Curves”, Retrieved From: http://ocw.metu.edu.tr/pluginfile.php/6886/mod_resource/content/1/ch8/8-3.htm Nov. 22, 2013, Middle East Technical University, 1999, 14 Pages.
- “Corrected Notice of Allowance”, U.S. Appl. No. 13/651,232, Jul. 31, 2014, 2 pages.
- “Corrected Notice of Allowance”, U.S. Appl. No. 13/651,287, Aug. 21, 2014, 2 pages.
- “Corrected Notice of Allowance”, U.S. Appl. No. 14/199,924, Aug. 29, 2014, 2 pages.
- “Corrected Notice of Allowance”, U.S. Appl. No. 14/199,924, Sep. 5, 2014, 2 pages.
- “Final Office Action”, U.S. Appl. No. 13/471,376, Aug. 18, 2014, 24 pages.
- “Final Office Action”, U.S. Appl. No. 13/595,700, Aug. 15, 2014, 6 pages.
- “Final Office Action”, U.S. Appl. No. 13/599,635, Aug. 8, 2014, 16 pages.
- “Final Office Action”, U.S. Appl. No. 13/655,065, Aug. 8, 2014, 20 pages.
- “Foreign Notice of Allowance”, CN Application No. 201320097065.3, Nov. 21, 2013, 2 pages.
- “Foreign Office Action”, CN Application No. 201320097065.3, Jun. 18, 2013, 2 pages.
- “International Search Report and Written Opinion”, Application No. PCT/US2013/028483, Jun. 24, 2014, 10 pages.
- “International Search Report and Written Opinion”, Application No. PCT/US2013/028484, Jun. 24, 2014, 10 pages.
- “International Search Report and Written Opinion”, Application No. PCT/US2013/028485, Jun. 25, 2014, 10 pages.
- “International Search Report and Written Opinion”, Application No. PCT/US2013/028769, Jun. 26, 2014, 10 pages.
- “International Search Report and Written Opinion”, Application No. PCT/US2013/028771, Jun. 19, 2014, 10 pages.
- “International Search Report and Written Opinion”, Application No. PCT/US2013/028486, Jun. 20, 2014, 10 pages.
- “International Search Report and Written Opinion”, Application No. PCT/US2013/041017, Jul. 17, 2014, 10 pages.
- “International Search Report and Written Opinion”, Application No. PCT/US2013/028489, Jun. 20, 2014, 11 pages.
- “International Search Report and Written Opinion”, Application No. PCT/US2013/028488, Jun. 24, 2014, 11 pages.
- “International Search Report and Written Opinion”, Application No. PCT/US2013/028767, Jun. 24, 2014, 11 pages.
- “International Search Report and Written Opinion”, Application No. PCT/US2014/016654, May 16, 2014, 11 pages.
- “International Search Report and Written Opinion”, Application No. PCT/US2013/028481, Jun. 19, 2014, 11 pages.
- “International Search Report and Written Opinion”, Application No. PCT/US2013/028490, Jun. 24, 2014, 11 pages.
- “International Search Report and Written Opinion”, Application No. PCT/US2013/028766, Jun. 26, 2014, 11 pages.
- “International Search Report and Written Opinion”, Application No. PCT/US2013/028772, Jun. 30, 2014, 11 pages.
- “International Search Report and Written Opinion”, Application No. PCT/US2013/028768, Jun. 24, 2014, 12 pages.
- “International Search Report and Written Opinion”, Application No. PCT/US2013/028482, Jun. 20, 2014, 13 pages.
- “International Search Report and Written Opinion”, Application No. PCT/US2013/028487, May 27, 2014, 9 pages.
- “International Search Report and Written Opinion”, Application No. PCT/US2013/028770, Jun. 26, 2014, 9 pages.
- “Non-Final Office Action”, U.S. Appl. No. 13/468,882, Jul. 9, 2014, 9 pages.
- “Non-Final Office Action”, U.S. Appl. No. 13/471,282, Sep. 3, 2014, 13 pages.
- “Non-Final Office Action”, U.S. Appl. No. 13/471,412, Jul. 11, 2014, 22 pages.
- “Non-Final Office Action”, U.S. Appl. No. 13/603,918, Sep. 2, 2014, 13 pages.
- “Non-Final Office Action”, U.S. Appl. No. 13/715,229, Aug. 19, 2014, 9 pages.
- “Non-Final Office Action”, U.S. Appl. No. 13/773,496, Jun. 23, 2014, 10 pages.
- “Non-Final Office Action”, U.S. Appl. No. 14/063,912, Sep. 2, 2014, 11 pages.
- “Notice of Allowance”, U.S. Appl. No. 13/471,030, Sep. 5, 2014, 6 pages.
- “Restriction Requirement”, U.S. Appl. No. 13/653,184, Sep. 5, 2014, 6 pages.
- “Supplemental Notice of Allowance”, U.S. Appl. No. 13/471,405, Aug. 29, 2014, 5 pages.
- “Teach Me Simply”, Retrieved From: http://techmesimply.blogspot.in/2013/05/yugatech_3.html on Nov. 22, 2013, May 3, 2013, pp. 1-6.
- Chavan, et al., “Synthesis, Design and Analysis of a Novel Variable Lift Cam Follower System”, In Proceedings: International Journal of Design Engineering, vol. 3, Issue 4, Inderscience Publishers, Jun. 3, 2010, 1 Page.
- Justin, “Seidio Active with Kickstand for the Galaxy SIII”, Retrieved From: <http://www.t3chniq.com/seidio-active-with-kickstand-gs3/> on Nov. 22, 2013, Jan. 3, 2013, 5 Pages.
- Lahr, “Development of a Novel Cam-based Infinitely Variable Transmission”, Proceedings: In Thesis of Master of Science in

(56)

References Cited

OTHER PUBLICATIONS

Mechanical Engineering, Virginia Polytechnic Institute and State University, Nov. 6, 2009, 91 pages.

Lambert, "Cam Design", In Proceedings: Kinematics and dynamics of Machine, University of Waterloo Department of Mechanical Engineering, Jul. 2, 2002, pp. 51-60.

Lee, et al., "LED Light Coupler Design for a Ultra Thin Light Guide", Journal of the Optical Society of Korea, vol. 11, Issue.3, Retrieved from <<http://opticslab.kongju.ac.kr/pdf/06.pdf>>, Sep. 2007, 5 pages.

Sanap, et al., "Design and Analysis of Globoidal Cam Index Drive", Proceedings: In International Journal of Scientific Research Engineering & Technology, Jun. 2013, 6 Pages.

Siddiqui, "Hinge Mechanism for Rotatable Component Attachment", U.S. Appl. No. 13/852,848, filed Mar. 28, 2013, 51 pages.

"Corrected Notice of Allowance", U.S. Appl. No. 14/727,001, Jan. 25, 2016, 2 pages.

"Corrected Notice of Allowance", U.S. Appl. No. 14/727,001, Dec. 15, 2015, 2 pages.

"Extended European Search Report", EP Application No. 13858283.8, Nov. 23, 2015, 10 pages.

"Extended European Search Report", EP Application No. 13858674.8, Nov. 27, 2015, 6 pages.

"Extended European Search Report", EP Application No. 13861292.4, Nov. 23, 2015, 7 pages.

"Final Office Action", U.S. Appl. No. 13/471,336, Dec. 10, 2015, 17 pages.

"Foreign Office Action", CN Application No. 201310067373.6, Dec. 23, 2015, 15 Pages.

"Foreign Office Action", CN Application No. 201310067429.8, Nov. 25, 2015, 12 Pages.

"Foreign Office Action", CN Application No. 201310067631.0, Dec. 10, 2015, 11 Pages.

"Foreign Office Action", CN Application No. 201310067641.4, Dec. 30, 2015, 12 Pages.

"Notice of Allowance", U.S. Appl. No. 14/059,280, Nov. 23, 2015, 9 pages.

"Notice of Allowance", U.S. Appl. No. 14/727,001, Dec. 15, 2015, 2 pages.

"Restriction Requirement", U.S. Appl. No. 14/794,182, Dec. 22, 2015, 6 pages.

"Foreign Office Action", CN Application No. 201310067356.2, Feb. 4, 2016, 15 Pages.

"Non-Final Office Action", U.S. Appl. No. 14/794,182, Apr. 13, 2016, 15 pages.

"Non-Final Office Action", U.S. Appl. No. 14/994,737, Apr. 5, 2016, 6 pages.

"Notice of Allowance", U.S. Appl. No. 14/517,048, Feb. 24, 2016, 8 pages.

"Restriction Requirement", U.S. Appl. No. 14/307,262, Mar. 21, 2016, 6 pages.

"Corrected Notice of Allowance", U.S. Appl. No. 14/517,048, Apr. 13, 2016, 2 pages.

"Final Office Action", U.S. Appl. No. 14/225,250, Jan. 29, 2016, 10 pages.

Corrected Notice of Allowance, U.S. Appl. No. 13/527,263, Apr. 12, 2016, 2 pages.

Corrected Notice of Allowance, U.S. Appl. No. 13/527,263, Apr. 25, 2016, 2 pages.

Extended European Search Report, EP Application No. 13728568.0, Mar. 14, 2016, 16 pages.

Extended European Search Report, EP Application No. 13858403.2, Mar. 16, 2016, 12 pages.

Extended European Search Report, EP Application No. 13860271.9, May 4, 2016, 8 pages.

Extended European Search Report, EP Application No. 13861059.7, Apr. 29, 2016, 8 pages.

Final Office Action, U.S. Appl. No. 13/471,393, Mar. 9, 2016, 17 pages.

Final Office Action, U.S. Appl. No. 13/492,232, May 25, 2016, 12 pages.

Final Office Action, U.S. Appl. No. 13/780,228, Mar. 23, 2016, 16 pages.

Foreign Notice of Allowance, CN Application No. 201310065273.X, Mar. 31, 2016, 4 Pages.

Foreign Notice of Allowance, CN Application No. 201320097079.5, Apr. 1, 2016, 4 Pages.

Foreign Notice of Allowance, CN Application No. 201310067531.8, Jun. 7, 2016, 4 pages.

Foreign Notice of Allowance, CN Application No. 201310067592.4, May 17, 2016, 4 pages.

Foreign Notice of Allowance, CN Application No. 201310067808.7, May 4, 2016, 4 pages.

Foreign Office Action, CN Application No. 201310067385.9, Apr. 14, 2016, 14 Pages.

Foreign Office Action, CN Application No. 201310067627.4, May 3, 2016, 7 pages.

Foreign Office Action, CN Application No. 201310096345.7, May 25, 2016, 16 Pages.

Foreign Office Action, CN Application No. 201310316114.2, Apr. 18, 2016, 11 pages.

Foreign Office Action, CN Application No. 201380025290.9, May 10, 2016, 15 pages.

Non-Final Office Action, U.S. Appl. No. 13/653,218, Apr. 20, 2016, 17 pages.

Non-Final Office Action, U.S. Appl. No. 13/689,541, Apr. 14, 2016, 23 pages.

Non-Final Office Action, U.S. Appl. No. 14/162,529, Apr. 6, 2016, 17 pages.

Non-Final Office Action, U.S. Appl. No. 14/307,262, Apr. 20, 2016, 10 pages.

Notice of Allowance, U.S. Appl. No. 13/468,882, May 24, 2016, 5 pages.

Notice of Allowance, U.S. Appl. No. 13/470,951, Mar. 24, 2016, 8 pages.

* cited by examiner

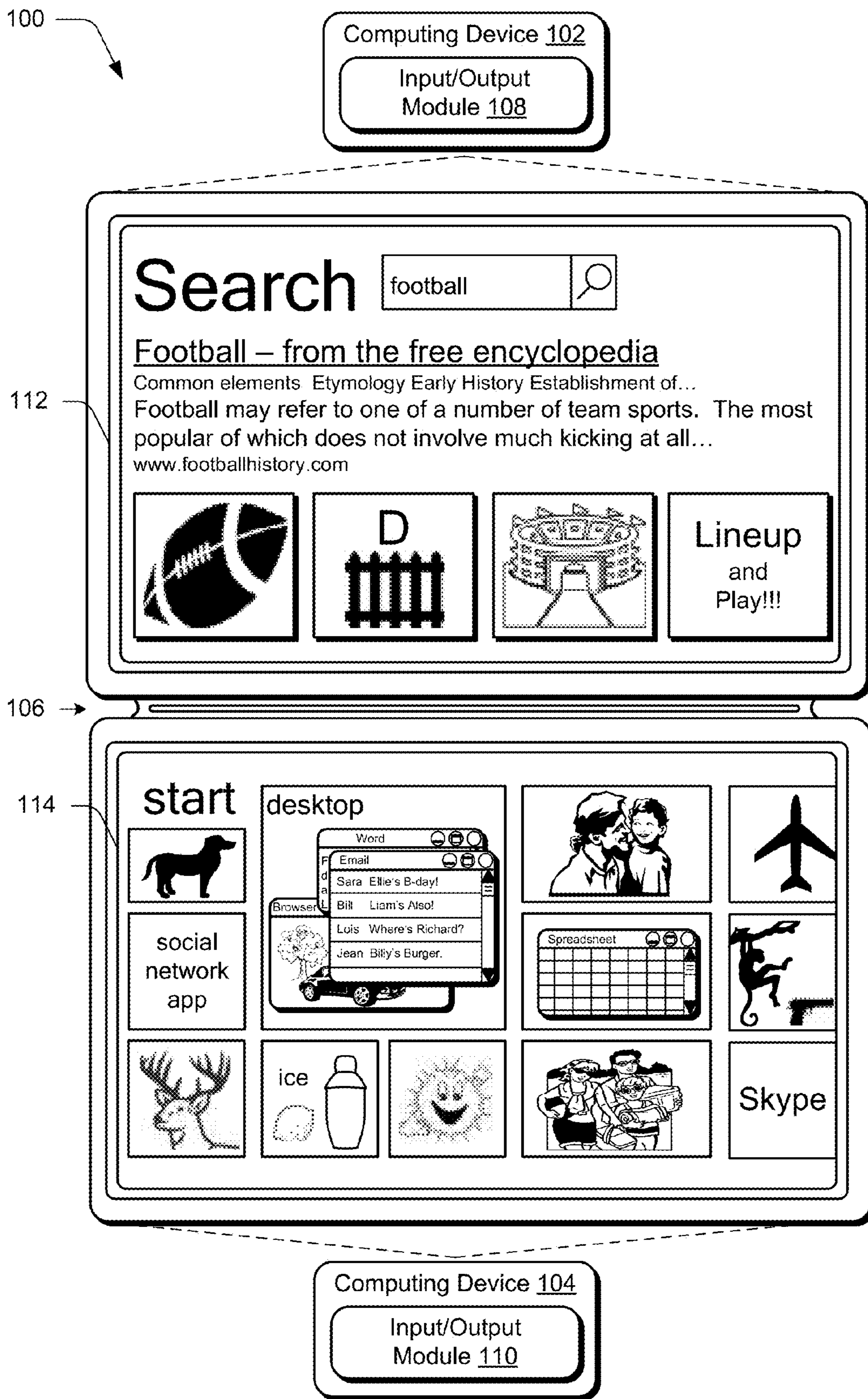
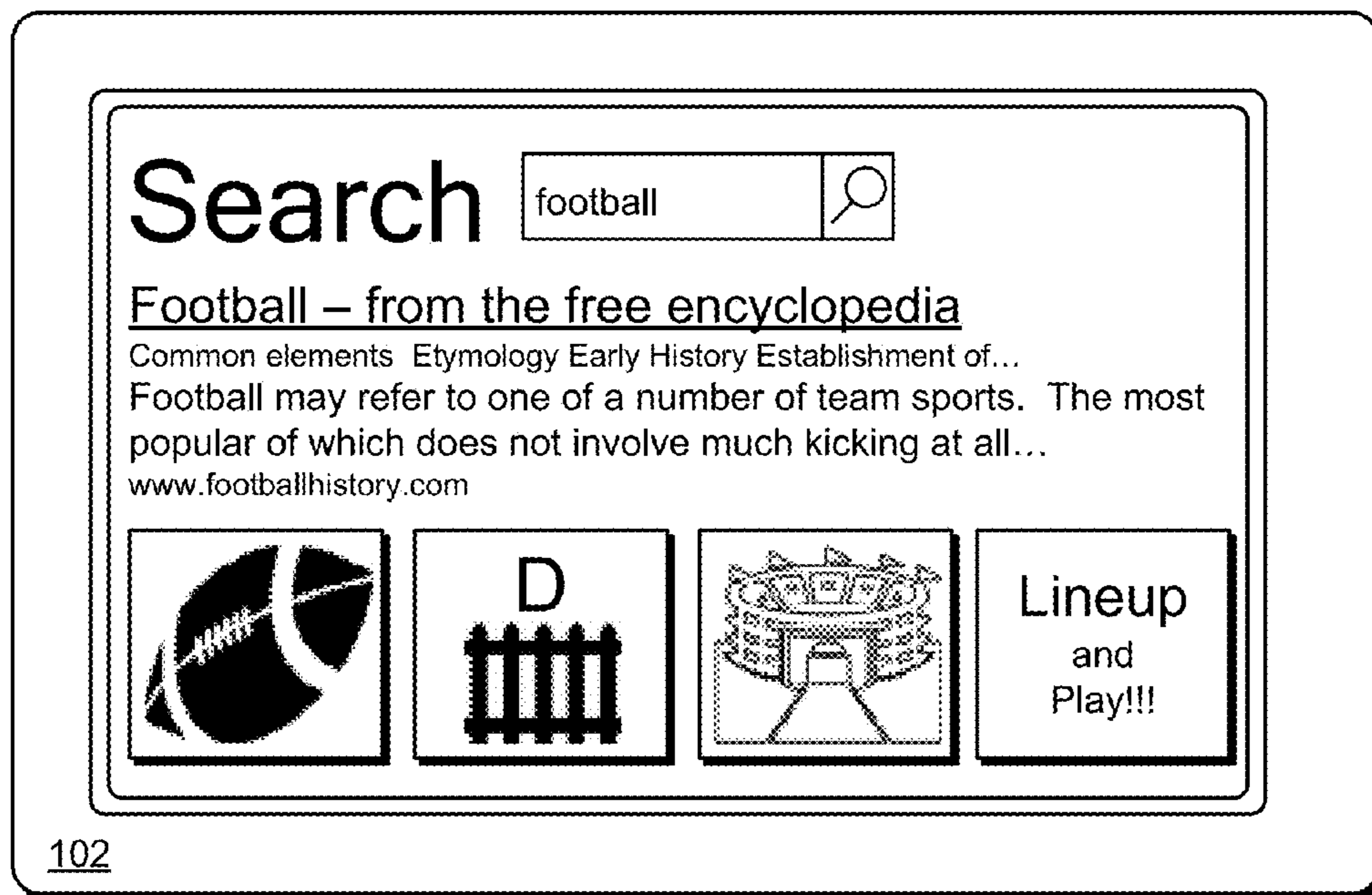

Fig. 1

200



202

204

106

206

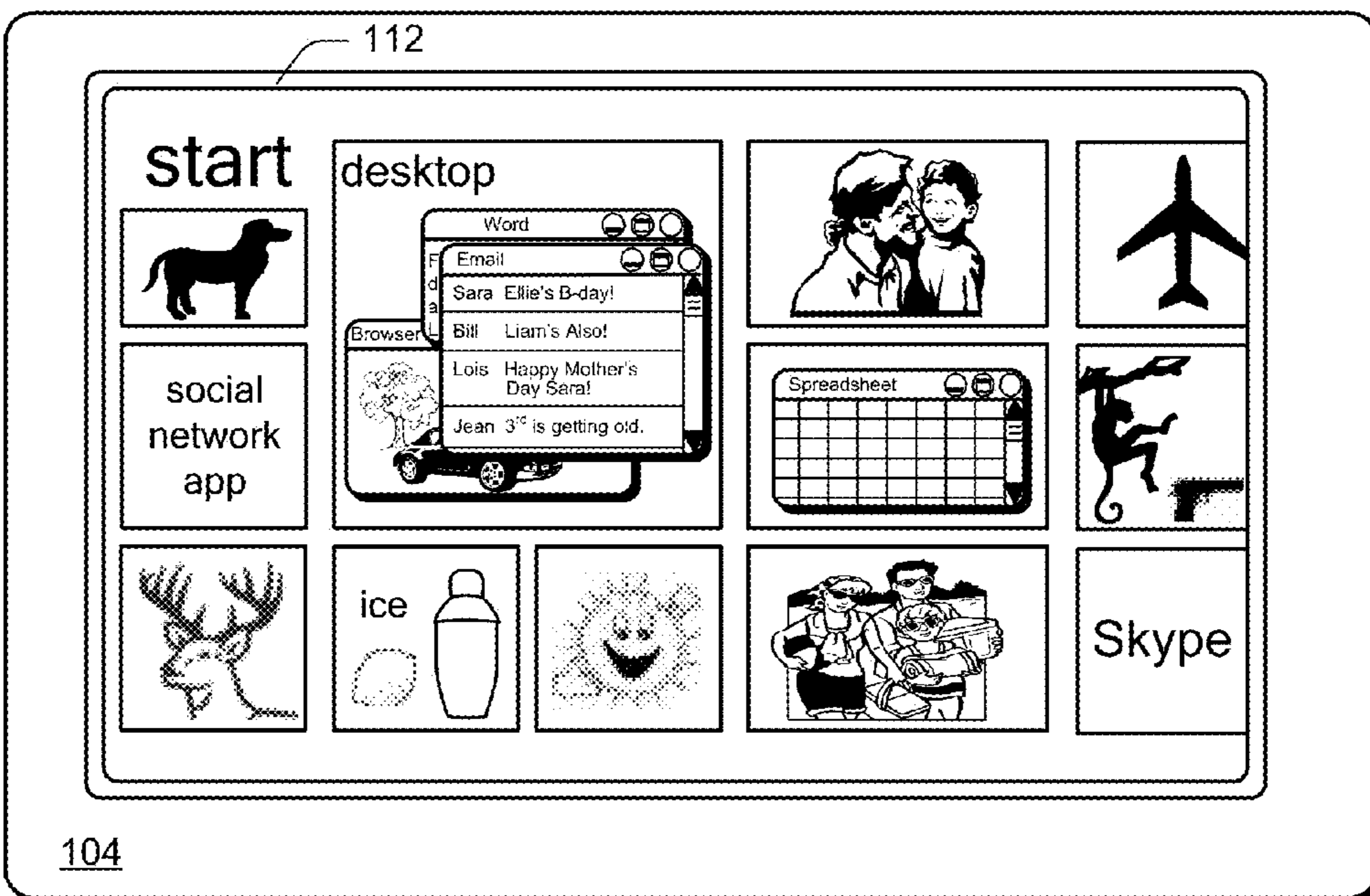
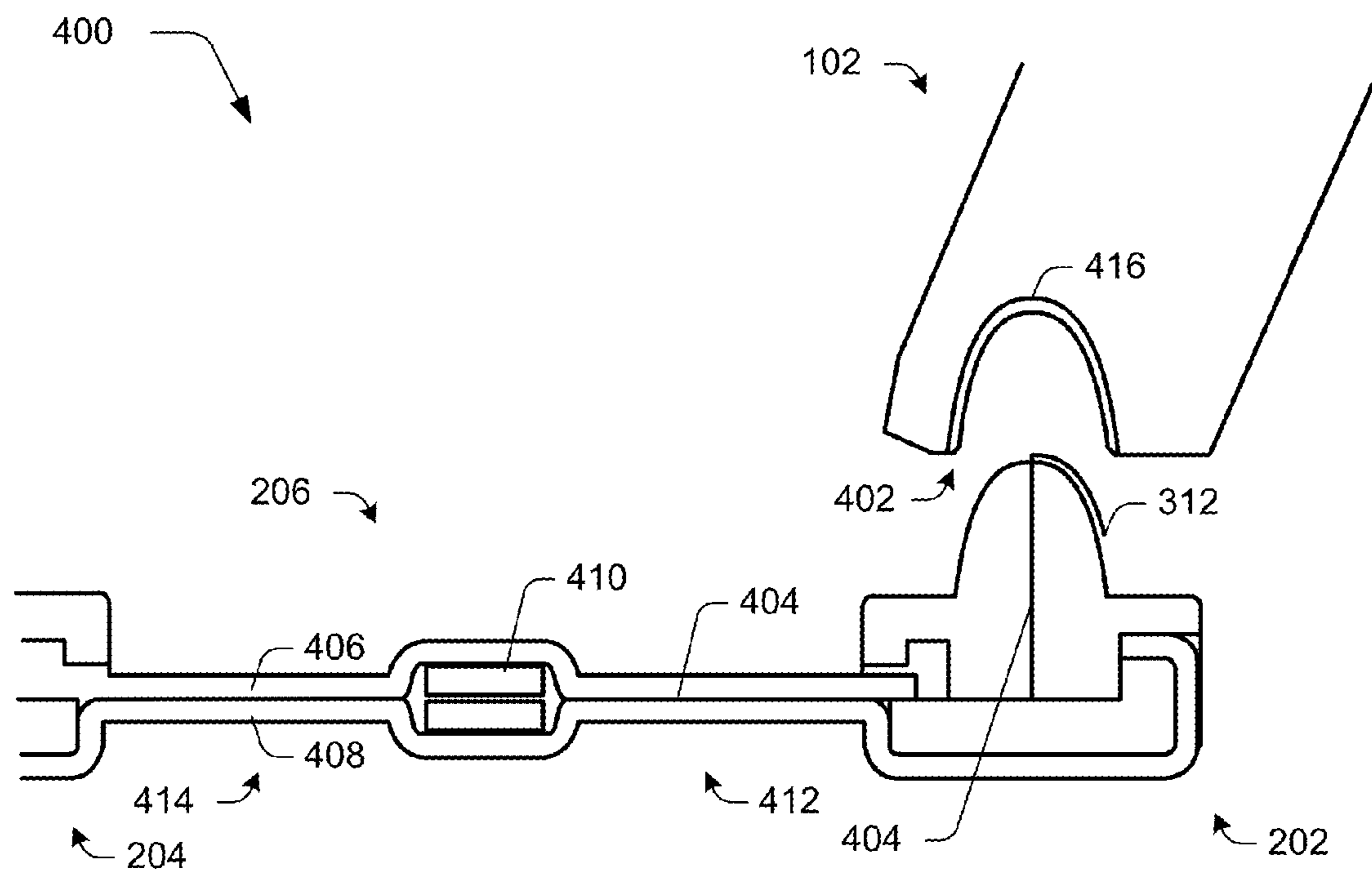
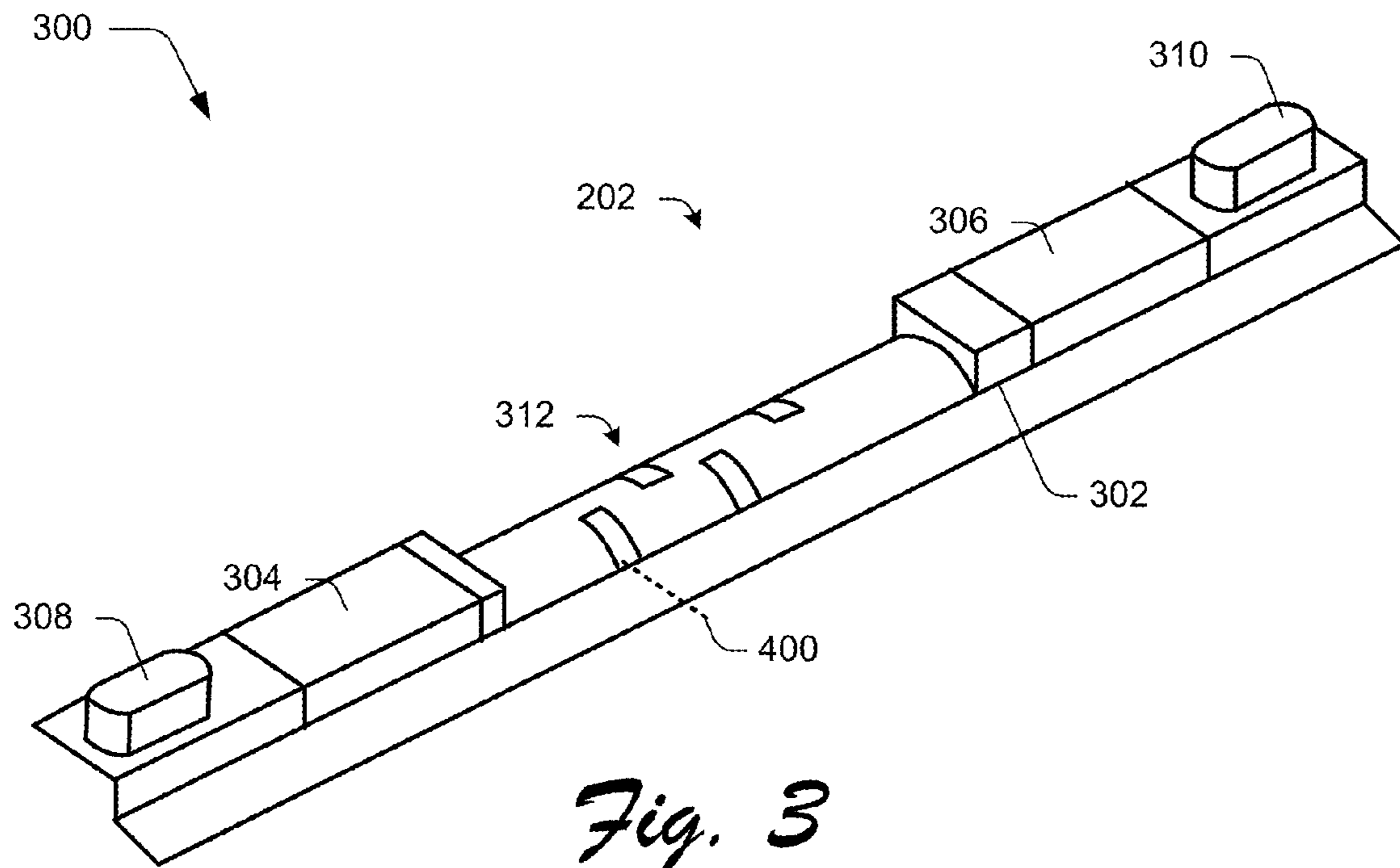

Fig. 2



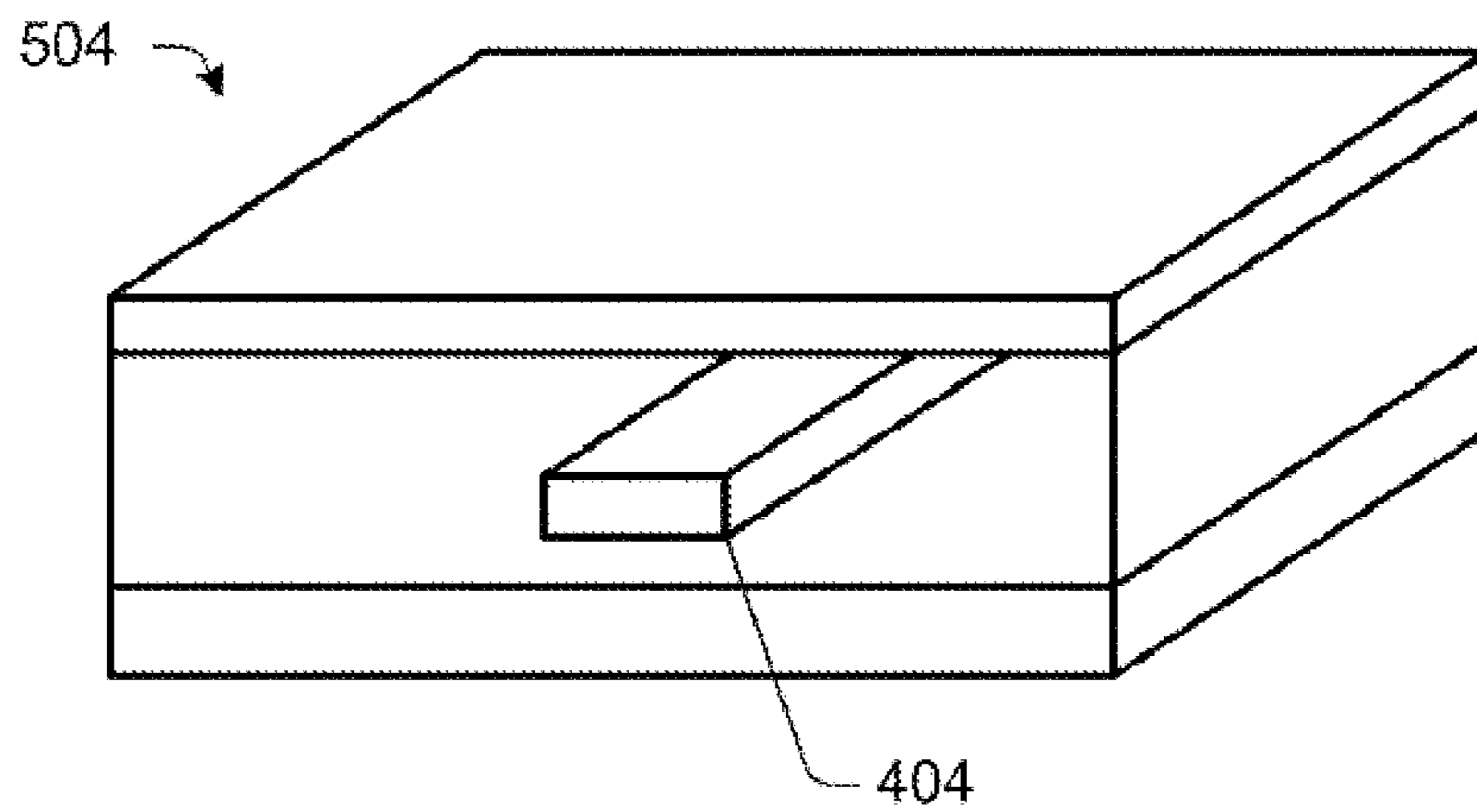
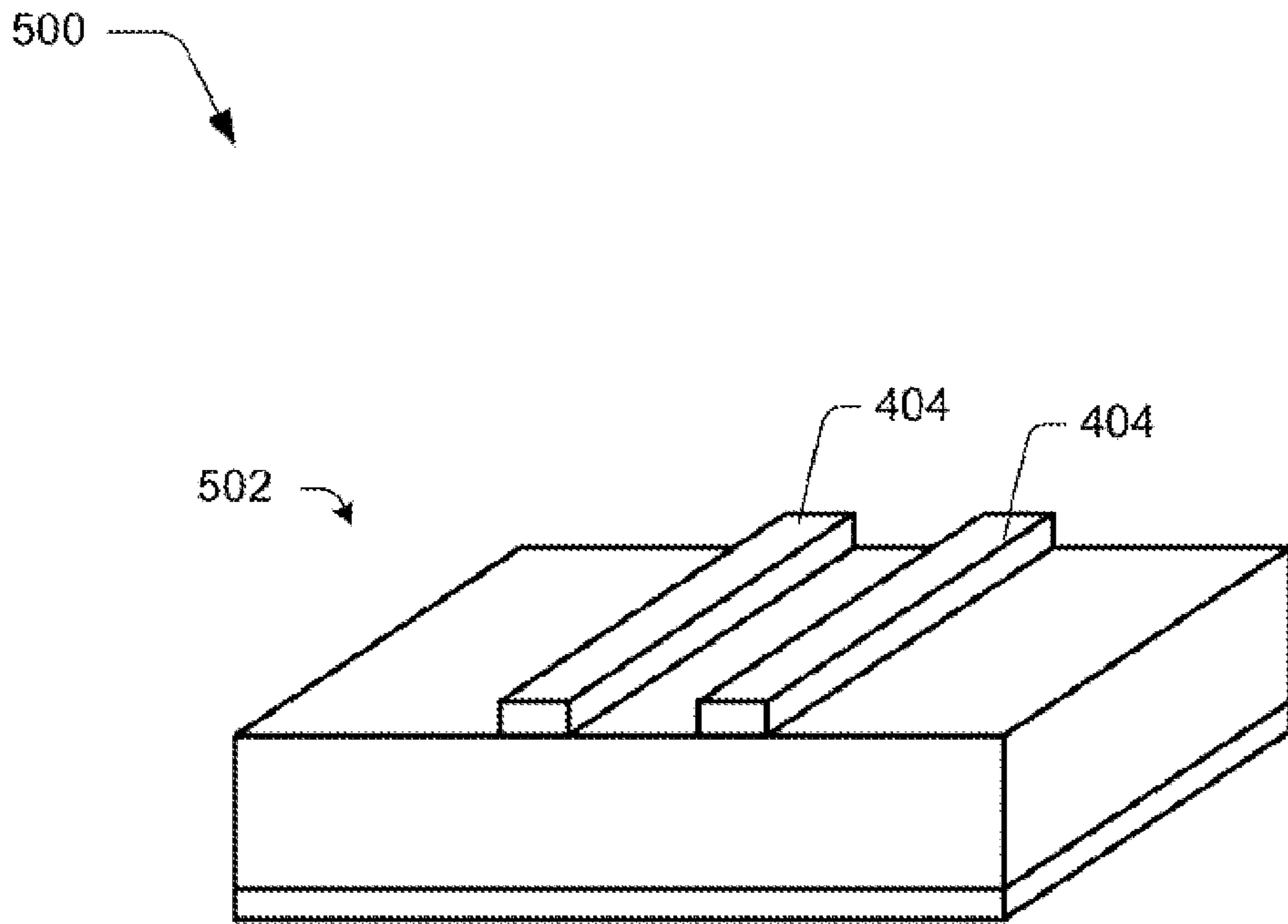

Fig. 5 (Amended)

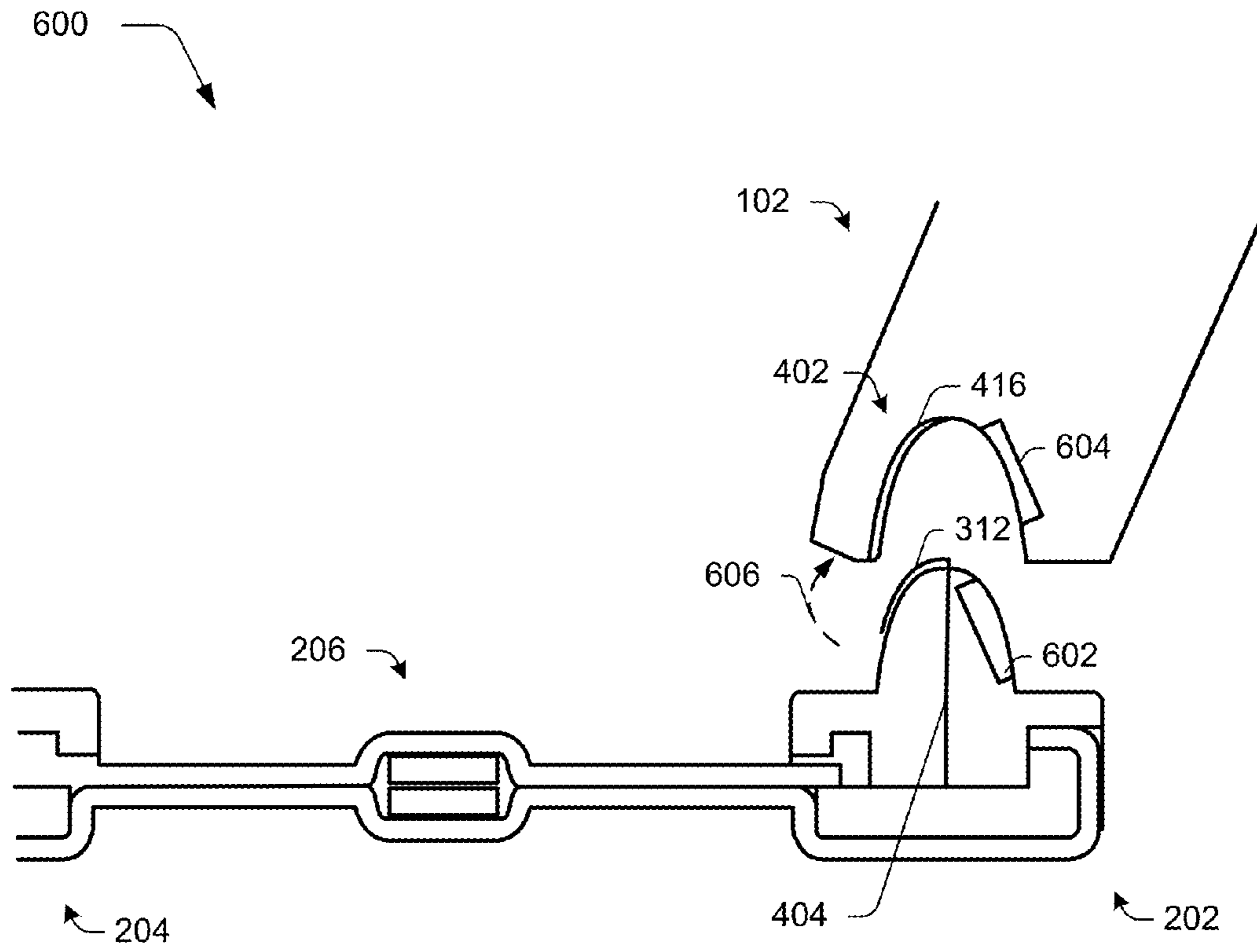

Fig. 6

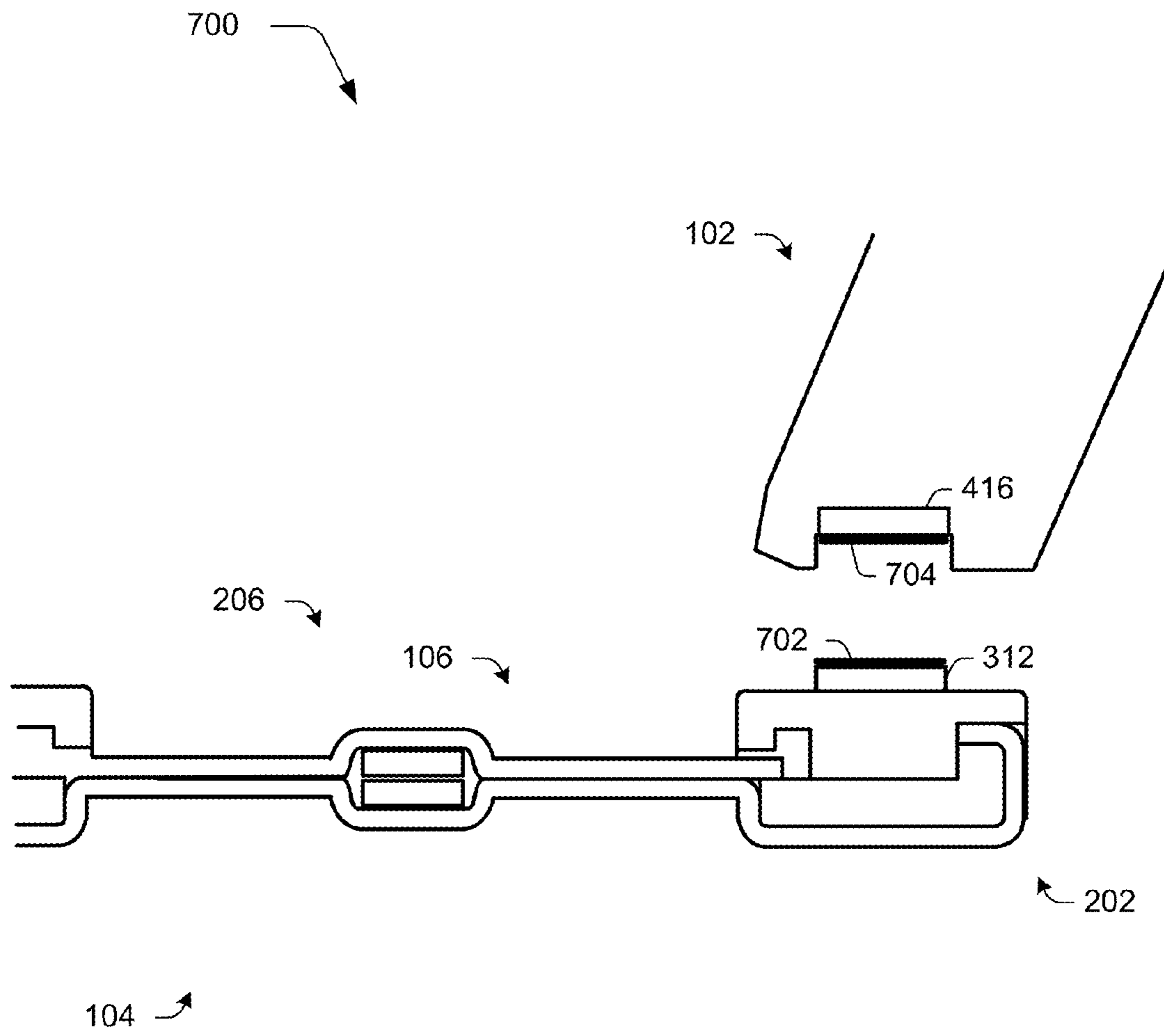

Fig. 7

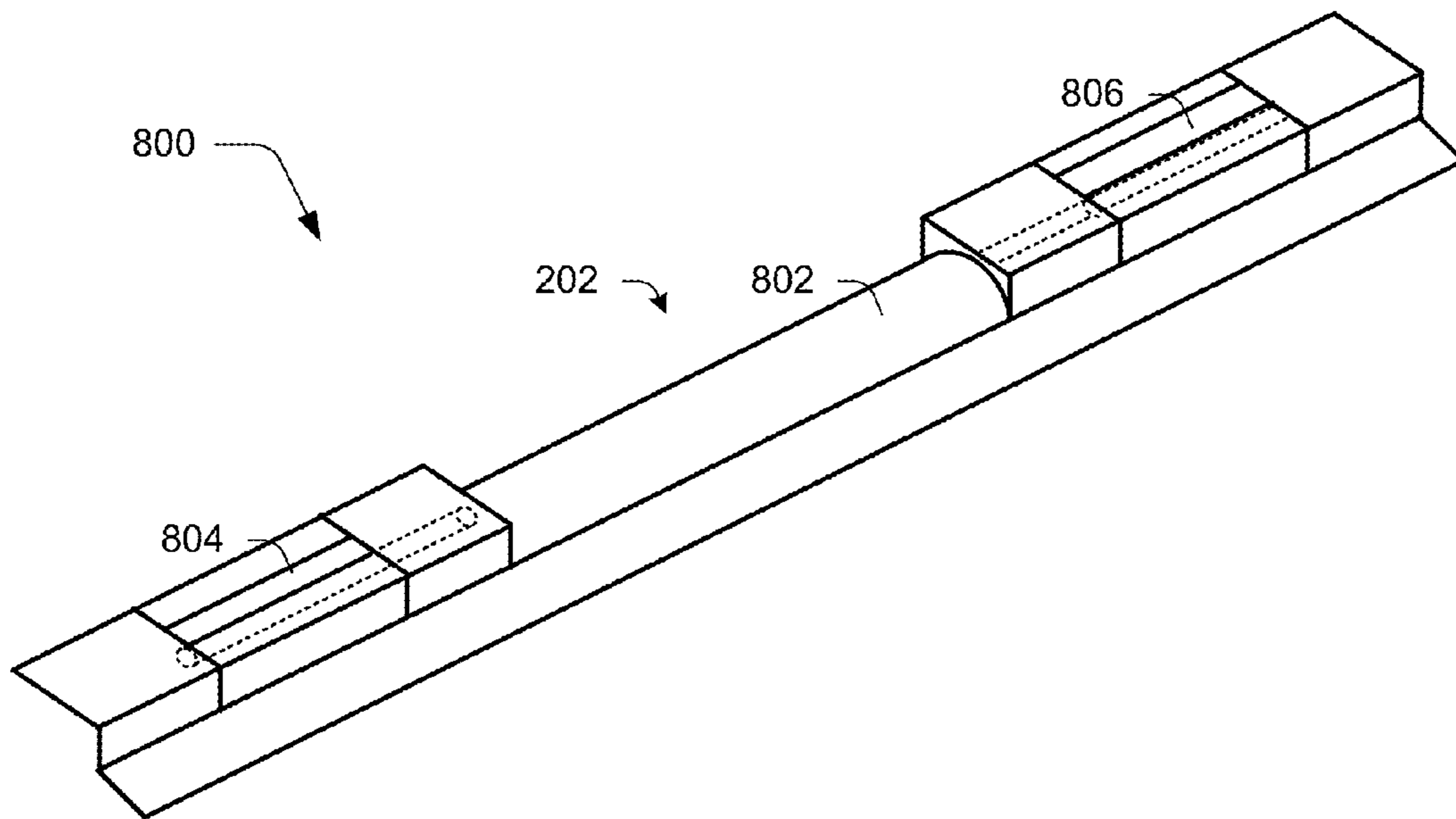

Fig. 8

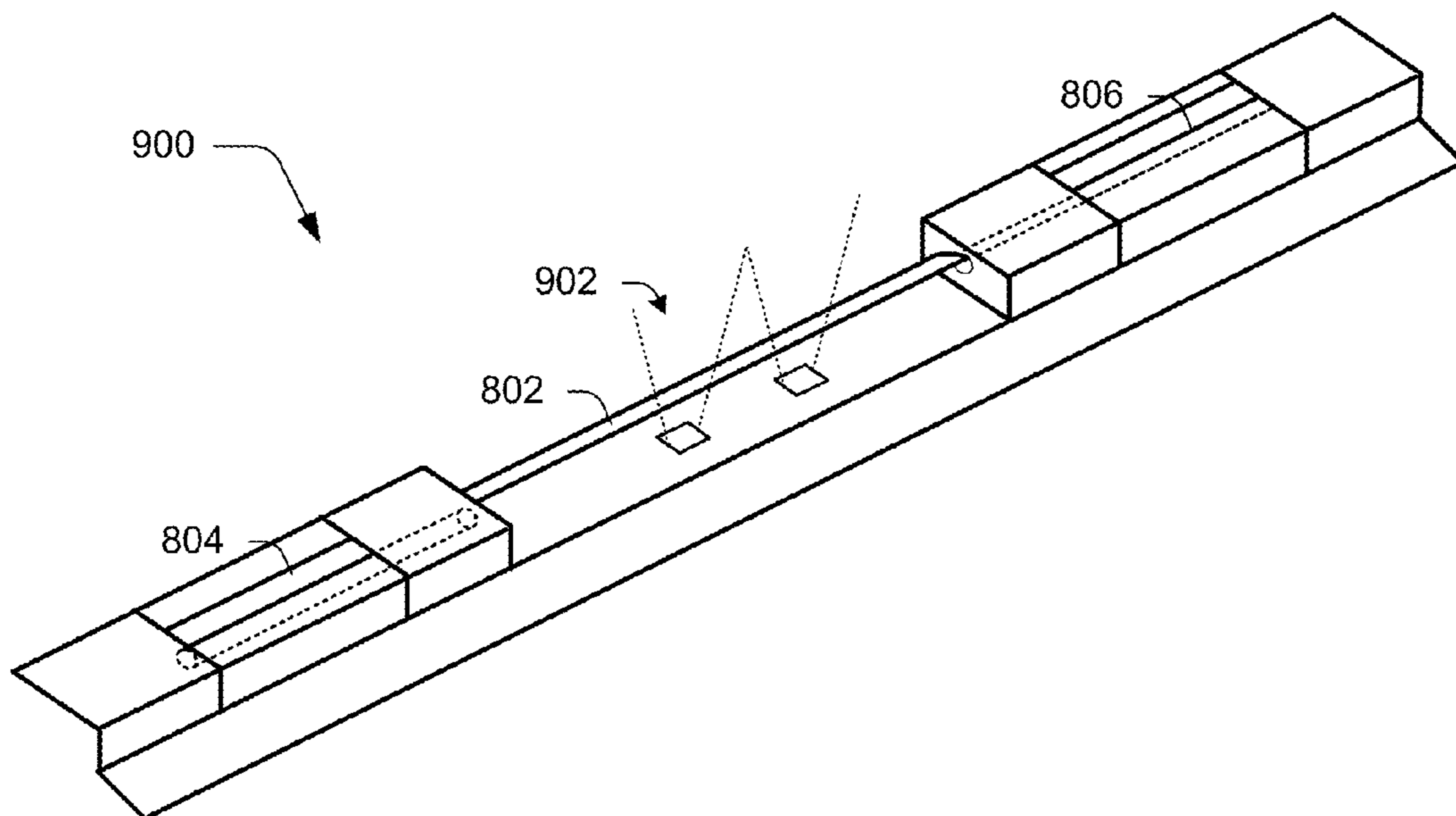

Fig. 9

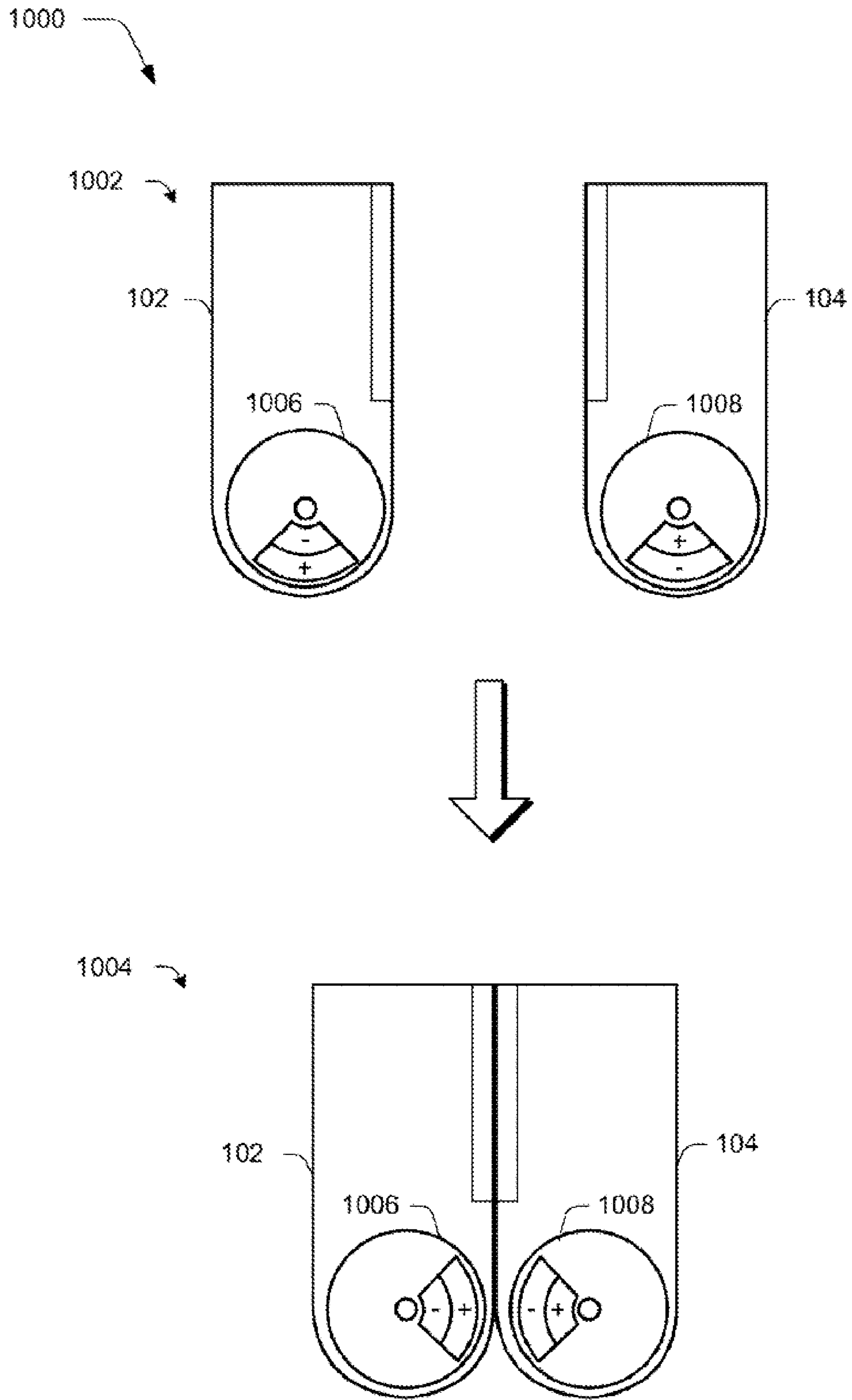

Fig. 10 (Amended)

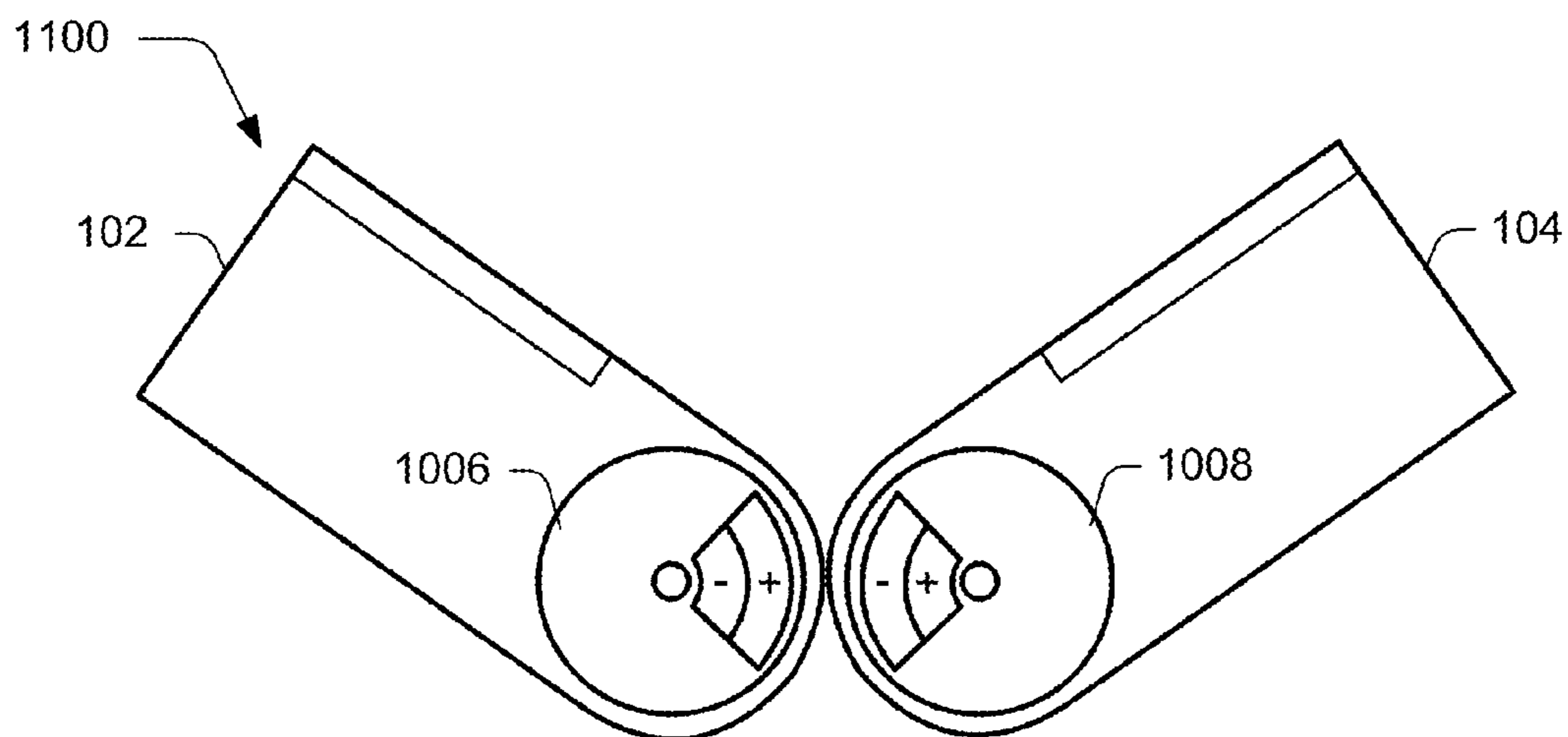

Fig. 11

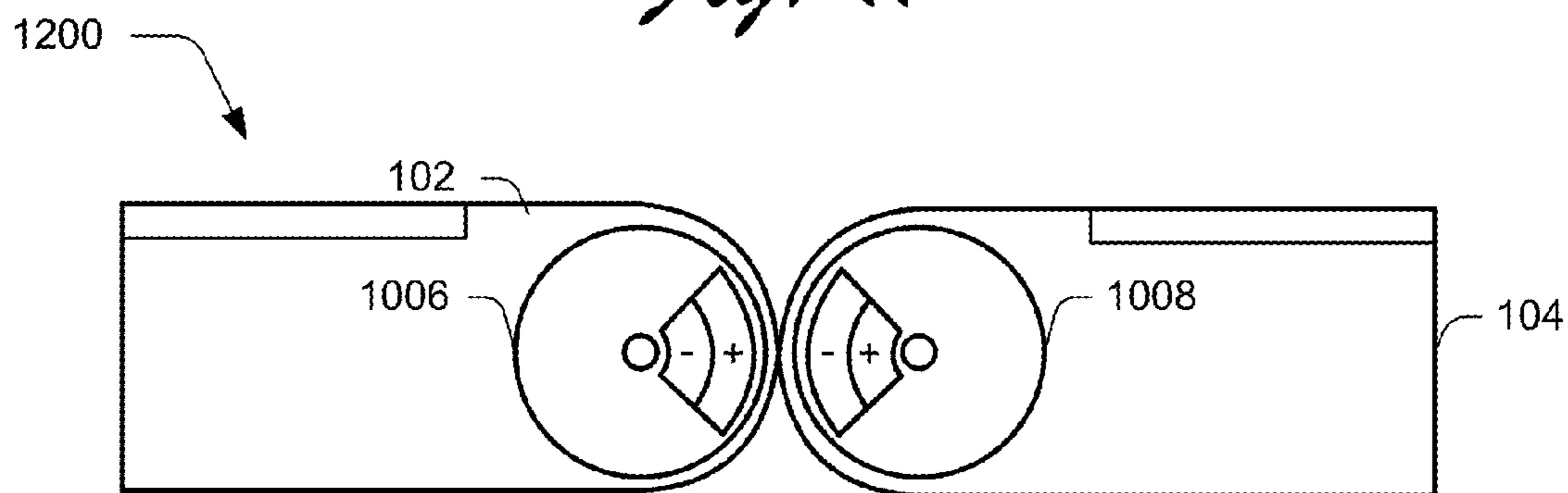

Fig. 12

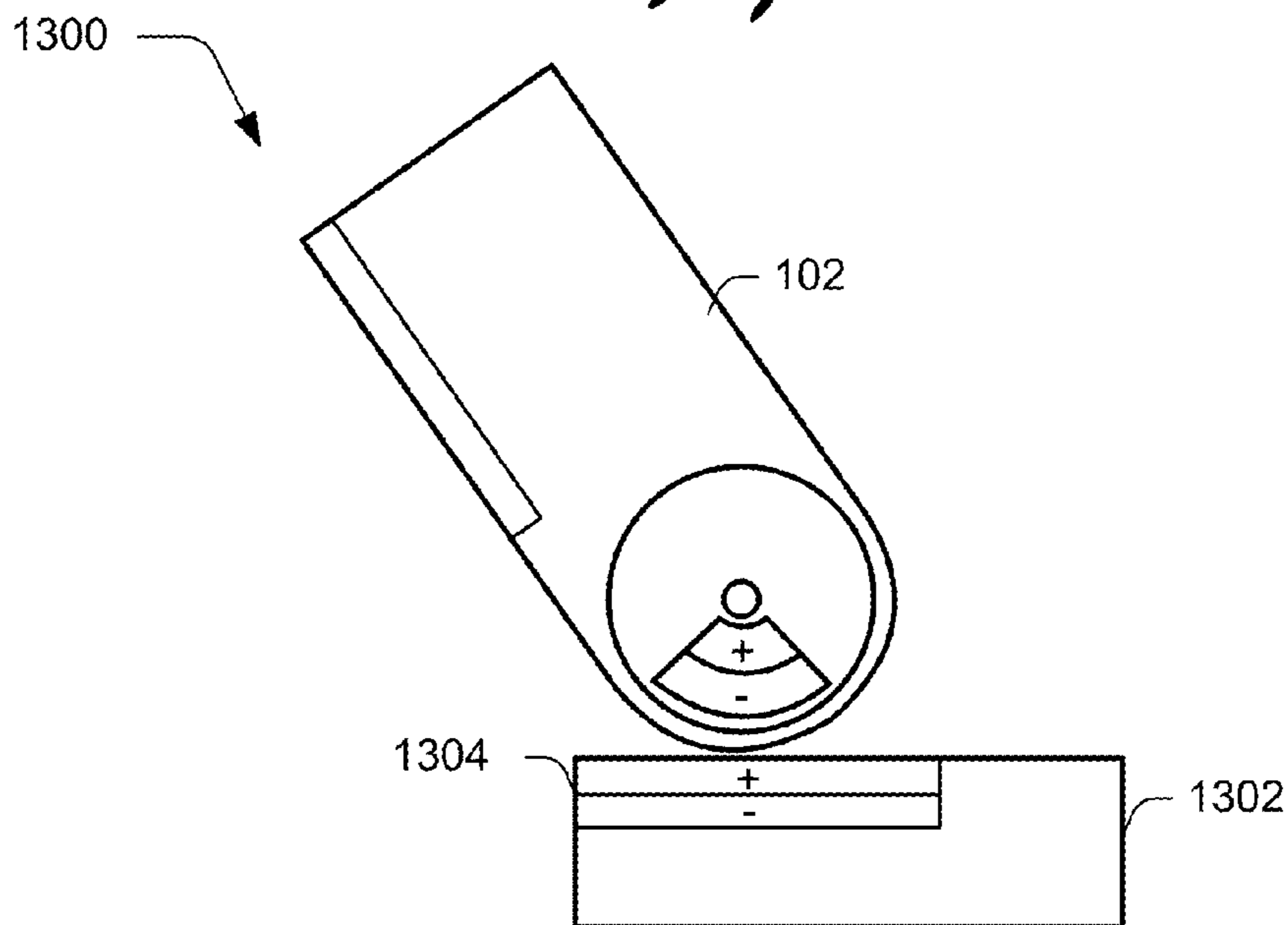

Fig. 13

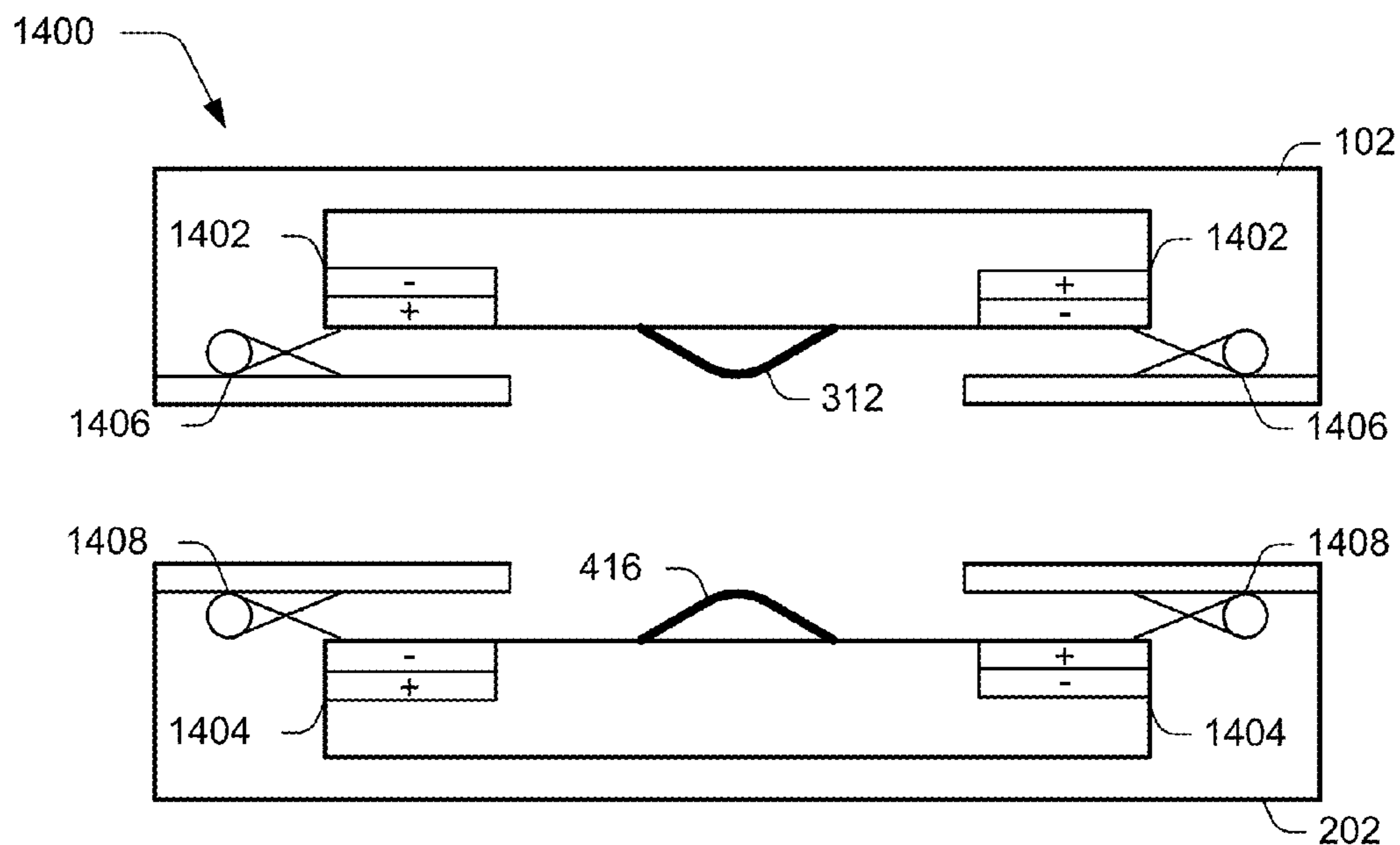

Fig. 14

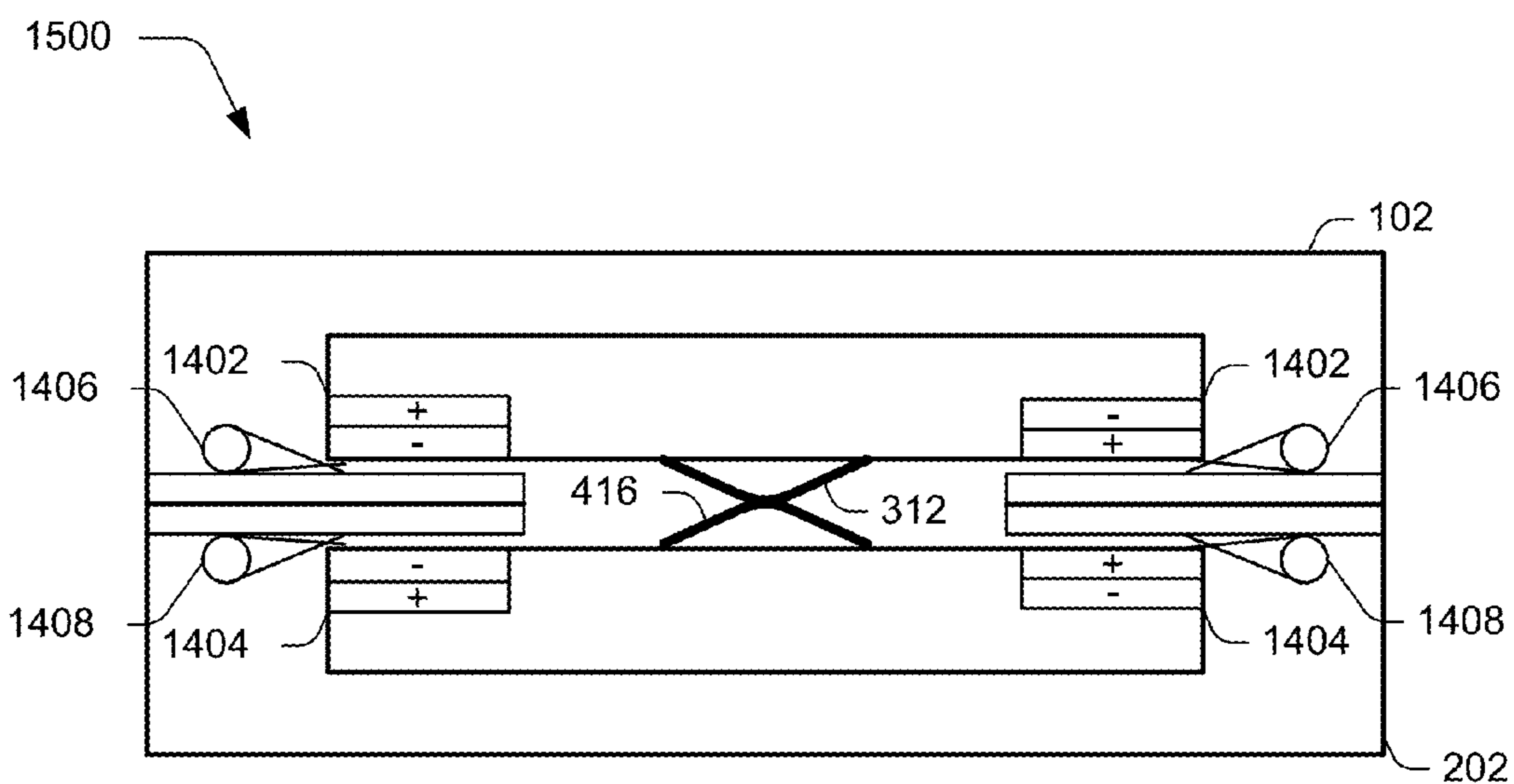

Fig. 15

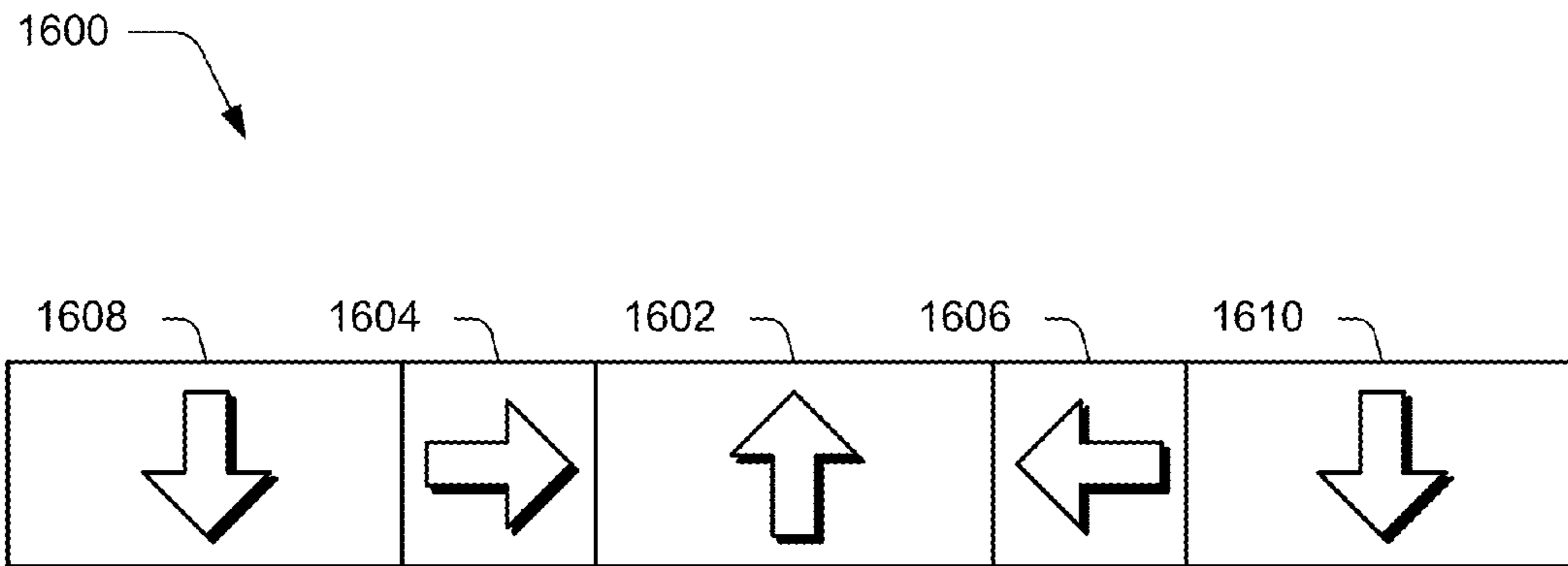

Fig. 16

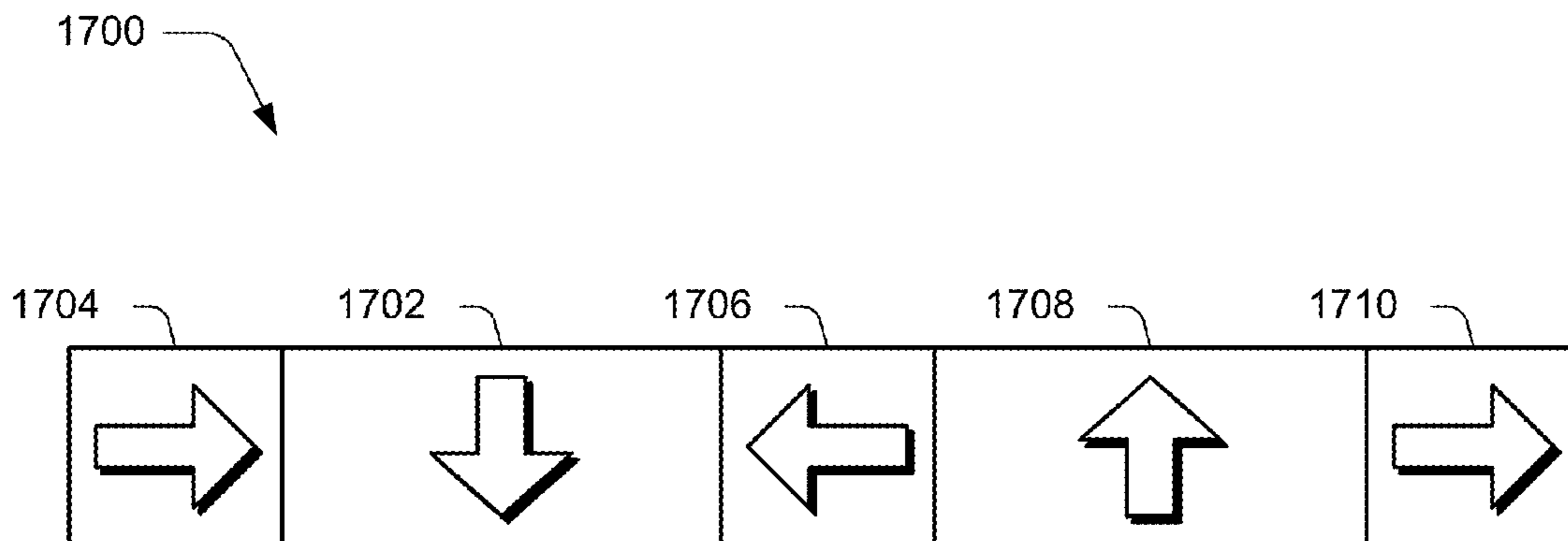

Fig. 17

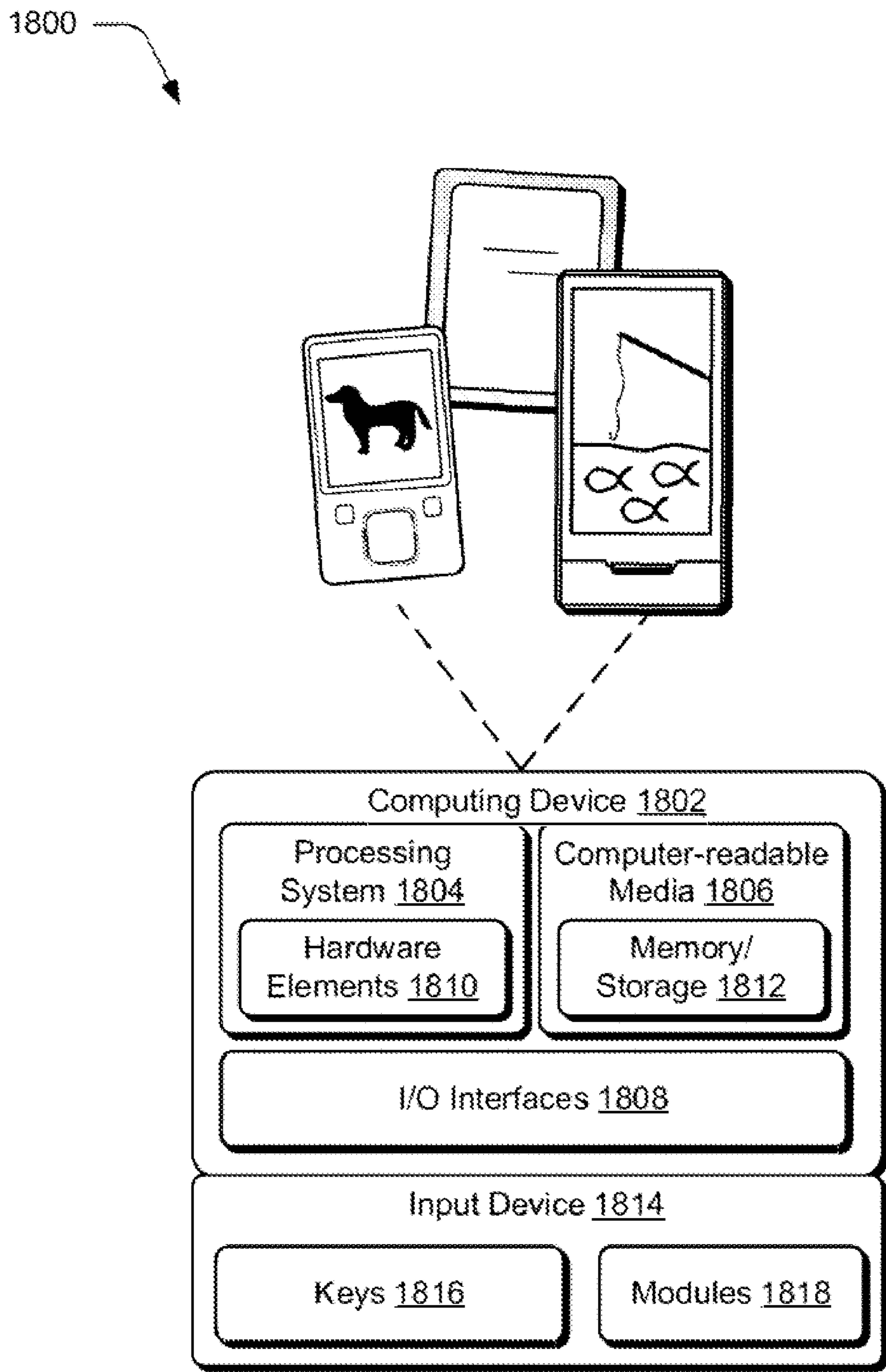

Fig. 18 (Amended)

CONNECTION DEVICE FOR COMPUTING DEVICES

Matter enclosed in heavy brackets [] appears in the original patent but forms no part of this reissue specification; matter printed in italics indicates the additions made by reissue; a claim printed with strikethrough indicates that the claim was canceled, disclaimed, or held invalid by a prior post-patent action or proceeding.

This application is a continuation-in-part and claims priority to U.S. patent application Ser. No. 13/470,633, filed May 14, 2012, entitled "Flexible Hinge and Removable Attachment," which further claims priority under 35 U.S.C. §119(e) to the following U.S. Provisional Patent Applications, the entire disclosures of each of these applications being incorporated by reference in their entirety:

U.S. Provisional Patent Application No. 61/606,321, filed Mar. 2, 2012, and titled "Screen Edge;"

U.S. Provisional Patent Application No. 61/606,301, filed Mar. 2, 2012, and titled "Input Device Functionality;"

U.S. Provisional Patent Application No. 61/606,313, filed Mar. 2, 2012, and titled "Functional Hinge;"

U.S. Provisional Patent Application No. 61/606,333, filed Mar. 2, 2012, and titled "Usage and Authentication;"

U.S. Provisional Patent Application No. 61/613,745, filed Mar. 21, 2012, and titled "Usage and Authentication;"

U.S. Provisional Patent Application No. 61/606,336, filed Mar. 2, 2012, and titled "Kickstand and Camera;" and

U.S. Provisional Patent Application No. 61/607,451, filed Mar. 6, 2012, and titled "Spanaway Provisional."

BACKGROUND

Users have access to a wide variety of different computing devices. For example, a user may interact with a mobile phone, tablet computer, or other mobile computing device to check email, surf the web, compose texts, interact with applications, and so on.

However, conventional techniques that were utilized to interact with these devices were often limited to the individual devices, themselves. Consequently, even though a user may have access to a wide range of devices and may have that access at any one time (e.g., a mobile phone and a tablet), interaction with these devices could be disjointed, thereby leading to user frustration.

SUMMARY

A connection device for computing devices is described. In one or more implementations, a connection device comprises a plurality of connection portions that are physically and communicatively coupled, one to another. Each of the plurality of connection portions has at least one communication contact configured to form a communicative coupling with a respective one of a plurality of computing devices and with at least one other communication contact of another one of the connections portions to support communication between the plurality of computing devices. Each of the plurality of connection portions also includes a magnetic coupling device to form a removable magnetic attachment to the respective one of the plurality of computing devices.

In one or more implementations, a system includes a first computing device having a housing that assumes a slate configuration and a second computing device having a

housing that assumes a slate configuration. The second computing device has a removable physical and communicative coupling with the second computing device, the removable physical communicative coupling provided at least in part through use of magnetism.

In one or more implementations, an apparatus comprises a plurality of connection portions that are configured to magnetically and physically communicatively couple a plurality of mobile computing devices having a slate form factor to each other.

This Summary is provided to introduce a selection of concepts in a simplified form that are further described below in the Detailed Description. This Summary is not intended to identify key features or essential features of the claimed subject matter, nor is it intended to be used as an aid in determining the scope of the claimed subject matter.

BRIEF DESCRIPTION OF THE DRAWINGS

The detailed description is described with reference to the accompanying figures. In the figures, the left-most digit(s) of a reference number identifies the figure in which the reference number first appears. The use of the same reference numbers in different instances in the description and the figures may indicate similar or identical items. Entities represented in the figures may be indicative of one or more entities and thus reference may be made interchangeably to single or plural forms of the entities in the discussion.

FIG. 1 is an illustration of an environment in an example implementation that is operable to employ the connection techniques described herein.

FIG. 2 depicts a system showing a connection device in greater detail that is usable to communicatively couple computing devices to each other.

FIG. 3 depicts an example implementation of a connection portion of a connection device of FIG. 2.

FIG. 4 depicts a cross section taken of the connection portion and a corresponding cavity of a computing device.

FIG. 5 depicts example implementations of the conductors that may be employed by the connection device to communicatively couple the connection portions to each other.

FIG. 6 depicts another example of a cross section taken of the connection portion and a corresponding cavity of the computing device, the connection portion configured to support cam-like movement.

FIG. 7 depicts another example of a cross section taken of the connection portion and a corresponding cavity of the computing device in which communication contacts are configured as capacitive-coupling pads.

FIG. 8 depicts another example in which the connection portion is configured to support an optical connection.

FIG. 9 shows an example in which a cover of FIG. 8 is opened to expose an optical sensor.

FIG. 10 depicts yet another example in which the computing devices include magnetic coupling portions configured as rotating magnetic hinges.

FIGS. 11-12 illustrate examples of rotation of the magnetic coupling portions in relation to each other may support a variety of different computing device orientations.

FIG. 13 depicts an example arrangement that supports a connection between the computing device and an accessory.

FIGS. 14 and 15 depict yet other examples in which the computing devices include magnetic coupling portions configured as rotating magnetic hinges.

FIG. 16 depicts an example of a magnetic coupling portion that may be employed by the computing devices or connection device to implement a flux fountain.

FIG. 17 depicts an example of a magnetic coupling portion that may be employed by the connection device or computing device to implement a flux fountain.

FIG. 18 illustrates an example system including various components of an example device that can be implemented as any type of computing device as described with reference to FIGS. 1-17 to implement embodiments of the techniques described herein.

DETAILED DESCRIPTION

Overview

Even though users may have access to a wide range of computing devices, conventional techniques to interact with these devices were provided by the computing devices separately. Accordingly, techniques are described herein to support physical and communicative connections between computing devices. For example, mobile computing devices such as tablets and phones may employ a slate form factor. A connection device may be used to provide a physical (e.g., magnetic) and communicative coupling between the devices, thereby permitting the devices to be used in combination, such as to expand an available display area, share processing and memory resources, and so on.

The connection device may be configured in a variety of ways. In one such example, the connection device includes a plurality of connection portions. Each of the connection portions is configured to connect to a respective computing device. This may be performed through a communication contact that is configured to support transmission bandwidths (e.g., hundreds of MHz) between the devices that are sufficient to communicate data for display without distortion, which may include the use of leaf springs, capacitive connections, optical connections, and so on.

A physical coupling may also be provided, at least in part, using magnets. The magnets, for instance, may be used to support a zero to negative insertion force to connect the computing device to the connection portion, e.g., such that the devices “click” together. Thus, a plurality of computing devices may be communicatively and physically coupled to the connection device, which may be used to support a variety of different usage scenarios, further discussion of which may be found in relation to the following sections.

In the following discussion, an example environment is first described that may employ the techniques described herein. Example procedures are then described which may be performed in the example environment as well as other environments. Consequently, performance of the example procedures is not limited to the example environment and the example environment is not limited to performance of the example procedures. Further, although connection of computing devices is described, other devices are also contemplated, such as covers. For example, these techniques are equally applicable to input devices and passive devices, e.g., a cover having one or more materials (e.g., magnets, ferrous material, and so on) that are configured and positioned within the cover to be attracted to magnetic coupling devices of the computing device, use of protrusions and connecting portion, and so on as further described below.

Example Environment

FIG. 1 is an illustration of an environment 100 in an example implementation that is operable to employ the

connection device techniques described herein. The illustrated environment 100 includes examples of computing devices 102, 104 that are physically and communicatively coupled via a connection device 106. The computing devices 102, 104 may be configured in a variety of ways. For example, computing devices 102, 104 may be configured for mobile use and therefore be referred to as mobile computing devices, such as a mobile phone, a tablet computer as illustrated, a portable game device, a portable music device, and so on. Other non-mobile examples are also contemplated, such as laptop computers, desktop computers, servers, and so on. Thus, the computing devices 102, 104 may range from full resource devices with substantial memory and processor resources to a low-resource device with limited memory and/or processing resources. The computing devices 102, 104 may also relate to software that causes the computing devices 102, 104 to perform one or more operations.

The computing devices 102, 104, for instance, are each illustrated as including a respective input/output module 108, 110. The input/output modules 108, 110 are representative of functionality relating to processing of inputs and rendering outputs of the respective computing device 102, 104. A variety of different inputs may be processed by the input/output modules 108, 110 such as inputs relating to functions that correspond to keys of an accessory device, keys of a virtual keyboard displayed by the display devices 112, 114 to identify gestures and cause operations to be performed that correspond to the gestures that may be recognized through touchscreen functionality, and so forth. Thus, the input/output modules 108, 110 may support a variety of different input techniques by recognizing and leveraging a division between types of inputs including key presses, gestures, and so on.

The computing devices 102, 104 are illustrated as being physically and communicatively coupled through use of a connection device 106. The connection device 106 may thus be used to support a variety of different usage scenarios for the computing devices 102, 104. This may include use of the computing devices 102, 104 in a manner that mimics a multi-monitor setup, a parent/child control arrangement, and so on. This may also include sharing resources of the devices, such as processing, memory, network connection, and other resources. In the illustrated example, computing device 104 displays a start screen on the display device 114 that is usable to select applications for execution and display by the display device 112 of computing device 102 as well as on a display device 114 of the computing device 104, itself. The connection device 106 may be configured in a variety of ways to support this connection, an example of which is described as follows and shown in a corresponding figure.

FIG. 2 depicts a system 200 showing a connection device 202 in greater detail that is usable to communicatively couple the computing devices 102, 104 to each other. In this example, the connection device 106 includes a plurality of connection portions 202, 204. Each of the connection portions 202, 204 is configured to be received in a respective cavity of a respective computing device 102, 104. In the illustrated instance, the connection portions 202, 204 may be attached to the respective computing devices 102, 104 in either direction as the shapes of the portions is symmetrical.

The computing devices 102, 104 may be configured to use the cavities to support connections to peripheral devices, such as keyboard, input devices, electronic paper display devices, and so on. Accordingly, in this example the connection device 106 may be configured to leverage this

connection to support a connection between computing devices as further described below.

The plurality of connection portions **202**, **204** are communicatively coupled in this example using a flexible hinge **206**. The flexible hinge **206** is flexible in that rotational movement supported by the hinge is achieved through flexing (e.g., bending) of the material forming the hinge as opposed to mechanical rotation as supported by a pin, although that embodiment is also contemplated. Further, this flexible rotation may be configured to support movement in one or more directions (e.g., vertically in the figure) yet restrict movement in other directions, such as lateral movement of the computing device **104** in relation to the computing device **102**. This may be used to support consistent alignment of the computing devices **102**, **104**.

The flexible hinge **206**, for instance, may be formed using one or more layers of fabric and include conductors formed as flexible traces to communicatively couple the input device **104** to the computing device **102** and vice versa. This communication, for instance, may be used to communicate inputs between the computing devices **102**, **104**, transfer power, perform authentication, and so on. The flexible hinge **206** may be configured in a variety of ways, further discussion of which may be found in relation to the following figure.

FIG. 3 depicts an example implementation **300** of the connection portion **202** of the connection device **106** of FIG. 2. In this example, the connection portion **202** is illustrated as having a protrusion **302** that is configured to be received in a cavity of a corresponding computing device **102** as described above. The protrusion **302** includes magnetic coupling devices **304**, **306**, mechanical coupling protrusions (e.g., “fangs”) **308**, **310**, and a plurality of communication contacts **312**. The magnetic coupling devices **304**, **306** are configured to magnetically couple to complementary magnetic coupling devices of the computing device **102** through use of one or more magnets. In this way, the connection portion **202** may be physically secured to the computing device **102** through use of magnetic attraction.

The connection portion **202** also includes mechanical coupling protrusions **308**, **310** to form a mechanical physical connection between the connection portion **202** and the computing device **102**. The mechanical coupling protrusions **308**, **310** are configured to extend away from a surface of the connection portion **202**, which in this case is perpendicular although other angles are also contemplated.

The mechanical coupling protrusions **308**, **310** are configured to be received within complimentary cavities within a channel of the computing device **102**. When so received, the mechanical coupling protrusions **308**, **310** promote a mechanical binding between the devices when forces are applied that are not aligned with an axis that is defined as correspond to the height of the protrusions and the depth of the cavity. In this way, the connection portion **202** may be separated from the computing device in a motion similar to tearing a page from a book but mechanically binds when confronted with other motions, thereby promoting a secure connection between the devices.

The connection portion **202** is also illustrated as including a plurality of communication contacts **312**. The plurality of communication contacts **312** is configured to contact corresponding communication contacts of the computing device **102** to form a communicative coupling between the devices as shown and discussed in greater detail in relation to the following figure.

FIG. 4 depicts a cross section **400** taken of the connection portion **202** and a corresponding cavity **402** of the comput-

ing device. In this example, the flexible hinge **206** is also shown in greater detail. The flexible hinge **206** in this cross section includes a conductor **404** that is configured to communicatively couple the connection portions **202**, **204** to each other. The conductor **404** may be formed in a variety of ways, such as a copper trace that has an operational flexibility to permit operation as part of the flexible hinge, e.g., to support repeated flexing of the flexible hinge **206**. Flexibility of the conductor **404**, however, may be limited, e.g., may remain operational to conduct signals for flexing that is performed above a minimum bend radius.

Accordingly, the flexible hinge **206** may be configured to support a minimum bend radius based on the operational flexibility of the conductor **404** such that the flexible hinge **206** resists flexing below that radius. A variety of different techniques may be employed. The flexible hinge **206**, for instance, may be configured to include first and second outer layers **406**, **408**, which may be formed from a fabric, microfiber cloth, and so on. Flexibility of material used to form the first and/or second outer layers **406**, **408** may be configured to support flexibility as described above such that the conductor **404** is not broken or otherwise rendered inoperable during movement of the connection portions **202**, **204** in relation to each other.

In another instance, the flexible hinge **206** may include a mid-spine **410** located between the connection portions **202**, **204**. The mid-spine **410**, for example, includes a first flexible portion **412** that flexibly connects the connection portion **202** to the mid-spine **410** and a second flexible portion **414** that flexibly connects the mid-spine **410** to the other connection portion **204**.

In the illustrated example, the first and second outer layers **406**, **408** extend over the first and second flexible portions **412**, **414** of the flexible hinge **206** and are secured to the connection portions **202**, **204**, e.g., via clamping, adhesive, and so on. The conductor **404** is disposed between the first and second outer layers **406**, **408** with the mid-spine **410** configured to provide mechanical stiffness to a particular location of the flexible hinge **206** to support a desired minimum bend radius.

The communication contact **312** is also shown in cross section in this example. The communication contact **312** in this example is configured as a spring pin that support sliding movement as part of engagement with communication contacts **416** in the cavity of the computing device **102**. This sliding motion may support surface cleaning of the communication contact **312**, thereby promoting a robust connection.

The communication contact **312** may be formed in a variety of different ways. This may include use of electrical transmission line principles to avoid distortion of the digital waveforms to provide generally uniform impedance through use of differential pairs of communication contacts **312**. A characteristic impedance may be set through controlled trace widths, trace-to-trace gaps, choice of dielectric material, and separations from a ground plane. Further, the communication contact **312** and/or conductor **404** may be disposed proximal to a dielectric that is adjacent to a ground plane to control impedance. Contact resistance of the communication contact **312** may also be configured. This in conventionally performed using a high insertion force to maintain a well-toleranced contact resistance.

However, in one or more implementations the connection portion **202** may be configured to employ a zero to negative insertion force. This may be performed by leveraging a clamping force provided by the magnetic coupling devices **304**, **306** providing a zero to negative insertion force of the

connection portion **202** to the computing device **102**. In this way, the connection portion **202** and the computing device **102** may “click” together with alignment provided automatically through the magnetic coupling devices **304**, **306**. As shown in FIG. 4, for instance, a sliding and clamping motion may be supported in the same movement to connect the devices, thereby promoting consistent impedance and cleanliness of the communication contacts **312**, **416**.

Once connected, the computing devices may determine an orientation relative to each other, which may be used to configure a user interface that continues across the devices. For example, the orientation of the device may be deduced individually and separately, such as through use of one or more orientation sensors by the device and knowledge of location of where the communication contacts are disposed on the device. In this way, an orientation of the device may be determined as well as a like orientation of a connected device.

In another example, the two [device] devices may communicate with each other, such as to acknowledge a computed orientation, e.g., whether in portrait or landscape mode as well as to the “right” or “left”, “top” or “bottom,” and so on. Thus, this example may have increased robustness. Other examples are also contemplated.

FIG. 5 depicts example implementations **500** of the conductors **404** that may be employed by the connection device **106** to communicatively couple the connection portions **202**, **204** to each other. In a first example **502**, a microstrip transmission line is shown in which conductors **404** have widths, heights, and spacing to provide desired transmission properties.

In one or more implementations, placement of the magnetic coupling portions near the communication contacts **312** and conductors **404** may cause capacitance near these structures to be modified, which may cause impedance disturbance and distortion of signals transmitted by the conductors. Therefore, in the second example **504**, a strip-line transmission line is shown in which the conductor **404** is disposed between two ground planes. In this way, signals transmitted by the conductor **404** may be protected from modified capacitance that may be caused by the magnetic coupling devices **304**, **306**. A variety of other examples are also contemplated.

FIG. 6 depicts another example **600** of a cross section taken of the connection portion **202** and a corresponding cavity **402** of the computing device **102**, the connection portion **202** configured to support cam-like movement. As before, the connection portion **202** is configured as a protrusion that is to be received within a cavity **402** of a computing device **102** such that communication contacts **312**, **416** form a communicative coupling.

In this example, the connection portion includes a magnet **602** that is configured to be attracted to a magnet **604** disposed as part of the cavity **402** of the computing device **102**. Due to the curved surfaces of the connection portion **202** and the cavity **402**, a cam action is caused by the attraction of the magnets **602**, **604** such that the connection portion **202** rotates **606** in relation to the cavity **402**. This rotation **606** causes the communication contact **312** to slide against the communication contact **416** of the computing device **102**, thereby cleaning the surfaces of the contacts and promoting a consistent communicative coupling as previously described. In these examples, the communication contact **312** is configured as a leaf spring, other examples are also contemplated which are described as follows and shown in a corresponding figure.

FIG. 7 depicts another example **700** of a cross section taken of the connection portion **202** and a corresponding cavity **402** of the computing device in which communication contacts **312**, **416** are configured as capacitive-coupling pads. As before, the connection portion **202** is configured as a protrusion that is to be received within a cavity **402** of a computing device **102** such that communication contacts **312**, **416** form a communicative coupling.

In this example, however, each of the communication contacts **312**, **416** includes a dielectric **702**, **704** disposed proximal to (e.g., covering) conductors of the communication contacts **312**, **416**. In this way, the communication contacts **312**, **416** form AC-coupling capacitors, thereby avoiding issues such as a firm and clean physical contact between the communication contacts **312**, **416**.

FIG. 8 depicts another example **800** in which the connection portion **202** is configured to support an optical connection. In this example, the connection portion **202** includes a cover **802** and two cover rotation mechanisms **804**, **806** that are coupled to the cover **802** using axles that are illustrated in phantom in the figure.

The two cover rotation mechanisms **804**, **806** are configured to bias the cover **802** in the closed position as shown in FIG. 8, such as through use of one or more return springs. The cover rotation mechanisms **804**, **806** include diametrically magnetized magnets that are configured to rotate the axles, which may be configured such that the magnets have magnetic field lines that are aligned at a right angle to a surface of the connection portion **202**.

Therefore, the cover rotation mechanisms **804**, **806** may be configured to rotate the cover **802** in the presence of a magnetic field having a corresponding alignment, e.g., from magnets of the computing device **102**. A cylindrical magnet of the cover rotation mechanisms **804**, **806**, for instance, may rotate against a return force of a biasing mechanism (e.g., a spring) to align with the field lines of the adjacent magnet of the computing device **102**, thereby opening the cover **802** as shown in the example implementation **900** of FIG. 9. Once the two devices are brought out of proximity, the biasing mechanism may cause the cover **802** to return to a closed position as shown in FIG. 8.

Once the cover **802** is opened as shown in FIG. 9, optical sensors **902** may be exposed on the connection portion **202** for communication with corresponding optical sensors of the computing device **102**. In this way, the optical sensors **902** may be protected from contaminants and support a high bandwidth connection between the computing devices **102**, **104**.

FIG. 10 depicts yet another example **1000** in which the computing devices **102**, **104** include magnetic coupling portions configured as rotating magnetic hinges. This example is shown through first and second stages **1002**, **1004**. At the first stage **1002**, the magnetic coupling portions **1006**, **1008** are integrated as part of the respective computing devices **102**, **104**. The magnetic coupling portions **1006**, **1008** are configured to support hinge-able attachment of the devices to each other. Connections for data and power between the two computing devices **102**, **104** may be connected to the same axle as the magnets so that the connections of the respective computing devices **102**, **104** face each other when brought together.

The magnetic coupling portions **1006**, **1008**, for instance, may employ spring-loaded rotating magnets. The magnet polarity is S-symmetric around the center of the edge being joined so that an identical pair of computing devices **102**, **104** may be connected by rotating one of the magnetic coupling portions **1006**, **1008** at 180 degrees compared to

the other, as shown in the second stage **1004**. Thus, when the computing devices **102**, **104** are brought together, the magnets rotate around their axis and pull the “hinge” together. Matching/interlocking dimples or ridges may also be employed for fine-grain alignment of the computing devices **102**, **104** to each other. Thus, the magnets may rotate around an axis but are lightly spring-loaded to return to a neutral state as shown in the first stage. For sake of clarity in the figure, near-end magnet orientation is shown.

Rotation of the magnetic coupling portions **1006**, **1008** in relation to each other may support a variety of different computing device **102**, **104** orientations, examples **1100**, **1200** are shown in FIGS. **11-12**. In the example **1300** shown in FIG. **13**, this arrangement may also be leveraged to support a connection between the computing device **102** and an accessory device **1302**, such as a keyboard or other input device. The accessory device **1302** may also include a complementary arrangement of magnets **1304** to support a similar physical and communicative coupling. Although the magnets shown in the previous examples are cylindrical, the face configured to support the physical connection may also be configured as substantially flat, which may increase the strength of the magnetic connection.

FIGS. **14** and **15** depict yet other examples **1400**, **1500** in which the computing devices **102**, **104** include magnetic coupling portions configured as rotating magnetic hinges. Communication contacts are generally kept relatively small for cost, real-estate, and impedance reasons and may be spring-loaded to maintain a consistent connection. Connecting surfaces of the communication contacts may be coated with a non-reactive, highly conductive metal such as gold, which may help maintain this functionality. However, this may leave a thin coating of metal over a small area that may be exposed to abrasion or snagging when the connector is not engaged. Further, in the case of connecting two identical computing devices directly, traditional socket/plug which could afford opportunities to recess the contacting surfaces may not “line up” for use in connection the devices directly.

Accordingly, the computing device **102** and connection portion **202** and/or another computing device **104** may employ retracting communication contacts **312**, **416**. The connection portion **202** and the computing device **102**, for instance, may include magnetic coupling devices **1402**, **1404** that are configured to be attracted to each other. The magnetic coupling devices **1402**, **1404** and respective communication contacts **312**, **416** may be disposed on a surface that is biased to a retracted state through one or more springs **1406**, **1408** as shown in FIG. **14**.

As the computing device **102** and connection portion **202** are brought together, however, attraction of the magnetic coupling devices **1402**, **1404** to each other may cause the springs **1406**, **1408** to compress and cause the communication contacts **312** to emerge and eventually touch as shown in the example **1500** of FIG. **15**. In this way, the communication contacts **312**, **416** may be protected from abrasion and contaminants yet still support a consistent connection between the devices. Once influence of the magnets is removed, the communication contacts **312**, **416** may return to a retracted state as shown in FIG. **14**. A variety of different configurations of magnets may be used as part of the magnetic coupling devices described in this example as well as the previous examples of FIGS. **1-13**, further examples of which are described as follows and shown in a corresponding figure.

FIG. **16** depicts an example **1600** of a magnetic coupling portion that may be employed by the connection device **106** or computing device **102** to implement a flux fountain. In

this example, alignment of a magnet field is indicted for each of a plurality of magnets using arrows.

A first magnet **1602** is disposed in the magnetic coupling device having a magnetic field aligned along an axis. Second and third magnets **1604**, **1606** are disposed on opposing sides of the first magnet **1602**. The alignment of the respective magnetic fields of the second and third magnets **1604**, **1606** is substantially perpendicular to the axis of the first magnet **1602** and generally opposed each other.

In this case, the magnetic fields of the second and third magnets are aimed towards the first magnet **1602**. This causes the magnetic field of the first magnet **1602** to extend further along the indicated axis, thereby increasing a range of the magnetic field of the first magnet **1602**.

The effect may be further extended using fourth and fifth magnets **1608**, **1610**. In this example, the fourth and fifth magnets **1608**, **1610** have magnetic fields that are aligned as substantially opposite to the magnetic field of the first magnet **1602**. Further, the second magnet **1604** is disposed between the fourth magnet **1608** and the first magnet **1602**. The third magnet **1606** is disposed between the first magnet **1602** and the fifth magnet **1610**. Thus, the magnetic fields of the fourth and fifth magnets **1608**, **1610** may also be caused to extend further along their respective axes which may further increase the strength of these magnets as well as other magnets in the collection. This arrangement of five magnets is suitable to form a flux fountain. Although five magnets were described, any odd number of magnets of five and greater may repeat this relationship to form flux fountains of even greater strength.

To magnetically attach to another magnetic coupling device, a similar arrangement of magnets may be disposed “on top” or “below” of the illustrated arrangement, e.g., so the magnetic fields of the first, fourth and fifth magnets **1602**, **1608**, **1610** are aligned with corresponding magnets above or below those magnets. Further, in the illustrated example, the strength of the first, fourth, and fifth magnets **1602**, **1608**, **1610** is stronger than the second and third magnets **1604**, **1606**, although other implementations are also contemplated. Another example of a flux fountain is described in relation to the following discussion of the figure.

FIG. **17** depicts an example **1700** of a magnetic coupling portion that may be employed by the connection device **106** or computing device **102** to implement a flux fountain. In this example, alignment of a magnet field is also indicted for each of a plurality of magnets using arrows.

Like the example **1600** of FIG. **16**, a first magnet **1702** is disposed in the magnetic coupling device having a magnetic field aligned along an axis. Second and third magnets **1704**, **1706** are disposed on opposing sides of the first magnet **1702**. The alignment of the magnetic fields of the second and third magnets **1704**, **1706** are substantially perpendicular the axis of the first magnet **1702** and generally opposed each other like the example **1600** of FIG. **16**.

In this case, the magnetic fields of the second and third magnets are aimed towards the first magnet **1702**. This causes the magnetic field of the first magnet **1702** to extend further along the indicated axis, thereby increasing a range of the magnetic field of the first magnet **1702**.

This effect may be further extended using fourth and fifth magnets **1708**, **1710**. In this example, the fourth magnet **1708** has a magnetic field that is aligned as substantially opposite to the magnetic field of the first magnet **1702**. The fifth magnet **1710** has a magnetic field that is aligned as substantially corresponding to the magnet field of the second magnet **1704** and is substantially opposite to the magnetic

field of the third magnet **1706**. The fourth magnet **1708** is disposed between the third and fifth magnets **1706**, **1710** in the magnetic coupling device.

This arrangement of five magnets is suitable to form a flux fountain. Although five magnets are described, any odd number of magnets of five and greater may repeat this relationship to form flux fountains of even greater strength. Thus, the magnetic fields of the first **1702** and fourth magnet **1708** may also be caused to extend further along its axis which may further increase the strength of this magnet.

To magnetically attach to another magnetic coupling device, a similar arrangement of magnets may be disposed “on top” or “below” of the illustrated arrangement, e.g., so the magnetic fields of the first and fourth magnets **1702**, **1708** are aligned with corresponding magnets above or below those magnets. Further, in the illustrated example, the strength of the first and fourth magnets **1702**, **1708** (individually) is stronger than a strength of the second, third and fifth magnets **1704**, **1706**, **1710**, although other implementations are also contemplated.

Further, the example **1600** of FIG. **16**, using similar sizes of magnets, may have increased magnetic coupling as opposed to the example **1700** of FIG. **17**. For instance, the example **1600** of FIG. **16** uses three magnets (e.g. the first, fourth, and fifth magnets **1602**, **1608**, **1610**) to primarily provide the magnetic coupling, with two magnets used to “steer” the magnetic fields of those magnets, e.g., the second and third magnets **1604**, **1606**. However, the example **1700** of FIG. **17** uses two magnets (e.g., the first and fourth magnets **1702**, **1708**) to primarily provide the magnetic coupling, with three magnets used to “steer” the magnetic fields of those magnets, e.g., the second, third, and fifth magnets **1704**, **1706**, **1708**.

Accordingly, though, the example **1700** of FIG. **17**, using similar sizes of magnets, may have increased magnetic alignment capabilities as opposed to the example **1600** of FIG. **16**. For instance, the example **1700** of FIG. **17** uses three magnets (e.g. the second, third, and fifth magnets **1704**, **1706**, **1710**) to “steer” the magnetic fields of the first and fourth magnets **1702**, **1708**, which are used to provide primary magnetic coupling. Therefore, the alignment of the fields of the magnets in the example **1700** of FIG. **17** may be closer than the alignment of the example **1600** of FIG. **16**.

Regardless of the technique employed, it should be readily apparent that the “steering” or “aiming” of the magnetic fields described may be used to increase an effective range of the magnets, e.g., in comparison with the use of the magnets having similar strengths by themselves in a conventional aligned state. In one or more implementations, this causes an increase from a few millimeters using an amount of magnetic material to a few centimeters using the same amount of magnetic material.

Example System and Device

FIG. **18** illustrates an example system generally at **1800** that includes an example computing device **1802** that is representative of one or more computing systems and/or devices that may implement the various techniques described herein. The computing device **1802** may be, for example, be configured to assume a mobile configuration through use of a housing formed and size to be grasped and carried by one or more hands of a user, illustrated examples of which include a mobile phone, mobile game and music device, and tablet computer although other examples are also contemplated.

The example computing device **1802** as illustrated includes a processing system **1804**, one or more computer-readable media **1806**, and one or more I/O interface **1808** that are communicatively coupled, one to another. Although not shown, the computing device **1802** may further include a system bus or other data and command transfer system that couples the various components, one to another. A system bus can include any one or combination of different bus structures, such as a memory bus or memory controller, a peripheral bus, a universal serial bus, and/or a processor or local bus that utilizes any of a variety of bus architectures. A variety of other examples are also contemplated, such as control and data lines.

The processing system **1804** is representative of functionality to perform one or more operations using hardware. Accordingly, the processing system **1804** is illustrated as including hardware element **1810** that may be configured as processors, functional blocks, and so forth. This may include implementation in hardware as an application specific integrated circuit or other logic device formed using one or more semiconductors. The hardware elements **1810** are not limited by the materials from which they are formed or the processing mechanisms employed therein. For example, processors may be comprised of semiconductor(s) and/or transistors (e.g., electronic integrated circuits (ICs)). In such a context, processor-executable instructions may be electronically-executable instructions.

The computer-readable storage media **1806** is illustrated as including memory/storage **1812**. The memory/storage **1812** represents memory/storage capacity associated with one or more computer-readable media. The memory/storage component **1812** may include volatile media (such as random access memory (RAM)) and/or nonvolatile media (such as read only memory (ROM), Flash memory, optical disks, magnetic disks, and so forth). The memory/storage component **1812** may include fixed media (e.g., RAM, ROM, a fixed hard drive, and so on) as well as removable media (e.g., Flash memory, a removable hard drive, an optical disc, and so forth). The computer-readable media **1806** may be configured in a variety of other ways as further described below.

Input/output interface(s) **1808** are representative of functionality to allow a user to enter commands and information to computing device **1802**, and also allow information to be presented to the user and/or other components or devices using various input/output devices. Examples of input devices include a keyboard, a cursor control device (e.g., a mouse), a microphone, a scanner, touch functionality (e.g., capacitive or other sensors that are configured to detect physical touch), a camera (e.g., which may employ visible or non-visible wavelengths such as infrared frequencies to recognize movement as gestures that do not involve touch), and so forth. Examples of output devices include a display device (e.g., a monitor or projector), speakers, a printer, a network card, tactile-response device, and so forth. Thus, the computing device **1802** may be configured in a variety of ways to support user interaction.

The computing device **1802** is further illustrated as being communicatively and physically coupled to an input device **1814** that is physically and communicatively removable from the computing device **1802**. In this way, a variety of different input devices may be coupled to the computing device **1802** having a wide variety of configurations to support a wide variety of functionality. In this example, the input device **1814** includes one or more keys **1816**, which may be configured as pressure sensitive keys, mechanically switched keys, and so forth.

The input device **1814** is further illustrated as include one or more modules **1818** that may be configured to support a variety of functionality. The one or more modules **1818**, for instance, may be configured to process analog and/or digital signals received from the keys **1816** to determine whether a keystroke was intended, determine whether an input is indicative of resting pressure, support authentication of the input device **1814** for operation with the computing device **1802**, and so on.

Various techniques may be described herein in the general context of software, hardware elements, or program modules. Generally, such modules include routines, programs, objects, elements, components, data structures, and so forth that perform particular tasks or implement particular abstract data types. The terms “module,” “functionality,” and “component” as used herein generally represent software, firmware, hardware, or a combination thereof. The features of the techniques described herein are platform-independent, meaning that the techniques may be implemented on a variety of commercial computing platforms having a variety of processors.

An implementation of the described modules and techniques may be stored on or transmitted across some form of computer-readable media. The computer-readable media may include a variety of media that may be accessed by the computing device **1802**. By way of example, and not limitation, computer-readable media may include “computer-readable storage media” and “computer-readable signal media.”

“Computer-readable storage media” may refer to media and/or devices that enable persistent and/or non-transitory storage of information in contrast to mere signal transmission, carrier waves, or signals per se. Thus, computer-readable storage media refers to non-signal bearing media. The computer-readable storage media includes hardware such as volatile and non-volatile, removable and non-removable media and/or storage devices implemented in a method or technology suitable for storage of information such as computer readable instructions, data structures, program modules, logic elements/circuits, or other data. Examples of computer-readable storage media may include, but are not limited to, RAM, ROM, EEPROM, flash memory or other memory technology, CD-ROM, digital versatile disks (DVD) or other optical storage, hard disks, magnetic cassettes, magnetic tape, magnetic disk storage or other magnetic storage devices, or other storage device, tangible media, or article of manufacture suitable to store the desired information and which may be accessed by a computer.

“Computer-readable signal media” may refer to a signal-bearing medium that is configured to transmit instructions to the hardware of the computing device **1802**, such as via a network. Signal media typically may embody computer readable instructions, data structures, program modules, or other data in a modulated data signal, such as carrier waves, data signals, or other transport mechanism. Signal media also include any information delivery media. The term “modulated data signal” means a signal that has one or more of its characteristics set or changed in such a manner as to encode information in the signal. By way of example, and not limitation, communication media include wired media such as a wired network or direct-wired connection, and wireless media such as acoustic, RF, infrared, and other wireless media.

As previously described, hardware elements **1810** and computer-readable media **1806** are representative of modules, programmable device logic and/or fixed device logic

implemented in a hardware form that may be employed in some embodiments to implement at least some aspects of the techniques described herein, such as to perform one or more instructions. Hardware may include components of an integrated circuit or on-chip system, an application-specific integrated circuit (ASIC), a field-programmable gate array (FPGA), a complex programmable logic device (CPLD), and other implementations in silicon or other hardware. In this context, hardware may operate as a processing device that performs program tasks defined by instructions and/or logic embodied by the hardware as well as a hardware utilized to store instructions for execution, e.g., the computer-readable storage media described previously.

Combinations of the foregoing may also be employed to implement various techniques described herein. Accordingly, software, hardware, or executable modules may be implemented as one or more instructions and/or logic embodied on some form of computer-readable storage media and/or by one or more hardware elements **1810**. The computing device **1802** may be configured to implement particular instructions and/or functions corresponding to the software and/or hardware modules. Accordingly, implementation of a module that is executable by the computing device **1802** as software may be achieved at least partially in hardware, e.g., through use of computer-readable storage media and/or hardware elements **1810** of the processing system **1804**. The instructions and/or functions may be executable/operable by one or more articles of manufacture (for example, one or more computing devices **1802** and/or processing systems **1804**) to implement techniques, modules, and examples described herein.

CONCLUSION

Although the example implementations have been described in language specific to structural features and/or methodological acts, it is to be understood that the implementations defined in the appended claims is not necessarily limited to the specific features or acts described. Rather, the specific features and acts are disclosed as example forms of implementing the claimed features.

What is claimed is:

1. A connection device comprising:

a plurality of connection portions that are physically and communicatively coupled, one to another, [the plurality of connection portions connected using a flexible hinge,] each of the plurality of connection portions having:

at least one communication contact configured to form a communicative coupling with a respective one of a plurality of computing devices and with at least one other communication contact of another one of the connections portions to support communication between the plurality of computing devices[, the flexible hinge having one or more conductors configured to communicatively couple the at least one communication contact with the at least one other communication contact]; [and]

a magnetic coupling device to form a removable magnetic attachment to the respective one of the plurality of computing devices;

a flexible hinge connecting the plurality of connection portions, the flexible hinge including:

a first connection portion of the plurality of connection portions;

a second connection portion of the plurality of connection portions;

15

a first outer layer extending between and secured to the first connection portion and the second connection portion;

a second outer layer extending between and secured to the first connection portion and the second connection portion;

a mid-spine between the first connection portion and the second connection portion, the mid-spine being located between the first outer layer and the second outer layer, the mid-spine being made from a stiffer material than the first outer layer and the second outer layer;

a first flexible portion between the first connection portion and the mid-spine;

a second flexible portion between the mid-spine and the second connection portion; and

one or more conductors disposed between the first outer layer and the second outer layer, the one or more conductors being configured to communicatively couple the at least one communication contact with the at least one other communication contact.

2. A connection device described in claim 1, wherein the flexible hinge is configured not to exceed a minimum bend radius that is defined at least in part based on flexibility of the one or more conductors.

3. A connection device as described in claim 1, wherein at least one of the plurality of connection portions is configured as a projection that is configured to be received within a channel of a housing of the respective one of the plurality of computing devices, the projection including the at least one communication contact and the magnetic coupling device.

4. A connection device as described in claim 1, wherein the plurality of computing devices include housings that support a slate configuration.

5. A connection device as described in claim 1, wherein the at least one communication contact is configured to support sliding motion as part of a physical coupling of the communication contact to the respective one of the plurality of computing devices, the sliding motion configured to at least partially clean a surface of the at least one communication contact.

6. A connection device as described in claim 5, wherein the sliding motion is configured to be assisted at least in part using magnetic attraction of the magnetic coupling device to the respective one of the plurality of computing devices.

7. A connection device as described in claim 1, wherein the at least one communication contact is configured to include a spring.

8. A connection device as described in claim 1, wherein at least one of the plurality of connection portions is formed such that the magnetic coupling device causes the respective connection portion to employ a cam action to support rotational movement as part of engagement of the at least one communication contact with the respective one of the plurality of computing devices.

9. A connection device as described in claim 1, wherein the at least one communication contact includes a dielectric coating in an amount sufficient to form a capacitive connection with a corresponding contact of the respective one of the plurality of computing devices.

10. A connection device as described in claim 1, wherein the at least one communication contact is configured to support an optical connection.

11. A connection device as described in claim 1, wherein at least one of the plurality of connection portions includes a rotating cover on an axle that is biased in a closed position

16

and is configured to assume an open position in which the at least one communication contact is exposed responsive to a magnetic field.

12. A connection device as described in claim 1, wherein the at least one communication contact and the at least one other communication contact are connected using one or more conductors configured as strip lines.

[13. A connection device as described in claim 1, wherein the magnetic coupling device has one or more rotatable magnets that have a symmetric magnetic polarity.]

14. A connection device as described in claim 1, wherein the at least one communication contact is configured to be moveable with respect to the respective connection portion between a retracted position and an exposed position responsive to magnetic interaction.

15. A connection device as described in claim 1, wherein the magnetic coupling device is configured as a flux fountain.

16. A system comprising:

a first computing device having a housing that assumes a slate configuration; and

a second computing device having a housing that assumes a slate configuration, the second computing device having:

a removable physical and communicative coupling with the first computing device, the removable physical communicative coupling provided at least in part through [use of]:

a flexible hinge physically and communicatively coupling a plurality of connection portions, one to another, each of the plurality of connection portions having at least one communication contact configured to form a communicative coupling with the first computing device and at least one other communication contact configured to form a communicative coupling with the second computing device, the flexible hinge having:

a first connection portion of the plurality of connection portions;

a second connection portion of the plurality of connection portions;

a first outer layer extending between and secured to the first connection portion and the second connection portion;

a second outer layer extending between and secured to the first connection portion and the second connection portion;

a mid-spine between the first connection portion and the second connection portion, the mid-spine being located between the first outer layer and the second outer layer, the mid-spine being made from a stiffer material than the first outer layer and the second outer layer;

a first flexible portion between the first connection portion and the mid-spine;

a second flexible portion between the mid-spine and the second connection portion; and

one or more conductors between the first outer layer and the second outer layer, the one or more conductors being configured to communicatively couple the at least one communication contact with the at least one other communication contact.

[17. A system as described in claim 16, wherein the flexible hinge has one or more rotatable magnets that have a symmetric magnetic polarity.]

17

18. A system as described in claim 16, wherein the flexible hinge is configured not to exceed a minimum bend radius that is defined at least in part based on flexibility of the one or more conductors.

19. An apparatus comprising:

a plurality of connection portions that are configured to magnetically and physically communicatively couple a plurality of mobile computing devices having a slate form factor to each other, the plurality of connection portions connected using:

a flexible hinge having:

a first connection portion of the plurality of connection portions;

a second connection portion of the plurality of connection portions;

a first outer layer extending between and secured to the first connection portion and the second connection portion;

a second outer layer extending between and secured to the first connection portion and the second connection portion;

a mid-spine between the first connection portion and the second connection portion, the mid-spine being located between the first outer layer and the

18

second outer layer, the mid-spine being made from a stiffer material than the first outer layer and the second outer layer;

a first flexible portion between the first connection portion and the mid-spine;

a second flexible portion between the mid-spine and the second connection portion; and

one or more conductors *located between the first outer layer and the second outer layer and configured to communicatively couple at least one communication contact configured to form a communicative coupling with a respective one of the plurality of mobile computing devices with at least one other communication contact of another one of the connections portions.*

20. An apparatus as described in claim 19, wherein the magnetic coupling is provided by a magnetic coupling device configured to form a removable magnetic attachment to the respective one of the plurality of mobile computing devices, the removable magnetic attachment configured to provide a zero or negative insertion force of the connection portion to the respective one of the plurality of computing devices.

* * * * *