



US00RE48800E

(19) **United States**  
(12) **Reissued Patent**  
**Piskun et al.**

(10) **Patent Number:** **US RE48,800 E**  
(45) **Date of Reissued Patent:** **\*Nov. 2, 2021**

(54) **ENDOLUMINAL SYSTEM FOR GASTROINTESTINAL TREATMENT**

(58) **Field of Classification Search**  
CPC ... A61B 1/00085; A61B 1/00087; A61B 1/31; A61B 1/32

(71) Applicant: **Boston Scientific Scimed, Inc.**, Maple Grove, MN (US)

(Continued)

(72) Inventors: **Gregory Piskun**, Delray Beach, FL (US); **John To**, Newark, CA (US); **Mariel Fabro**, San Francisco, CA (US); **Brian Tang**, Fremont, CA (US); **Sergey Kantsevov**, Owings Mills, MD (US)

(56) **References Cited**

U.S. PATENT DOCUMENTS

457,787 A 8/1891 Leisenring  
827,193 A 7/1906 Thrash

(Continued)

(73) Assignee: **Boston Scientific Scimed, Inc.**, Maple Grove, MN (US)

FOREIGN PATENT DOCUMENTS

CN 1579352 A 2/2005  
CN 101048101 A 10/2007

(Continued)

(\*) Notice: This patent is subject to a terminal disclaimer.

OTHER PUBLICATIONS

(21) Appl. No.: **16/531,167**

*“Oleg Shikhman vs. Bobcat Endoscopy, LLC (F/K/A/ LumenR LLC) and Gregory Piskun, M.D. Complaint”*, filed on Oct. 17, 2017, at Judicial District of Fairfield at Bridgeport, 25 pages.

(22) Filed: **Aug. 5, 2019**

(Continued)

**Related U.S. Patent Documents**

Reissue of:

(64) Patent No.: **9,737,194**  
Issued: **Aug. 22, 2017**  
Appl. No.: **14/929,214**  
Filed: **Oct. 30, 2015**

*Primary Examiner* — Beverly M Flanagan  
(74) *Attorney, Agent, or Firm* — Kacvinsky Daisak Bluni PLLC

U.S. Applications:

(63) Continuation of application No. 13/862,346, filed on Apr. 12, 2013, now Pat. No. 9,186,130, which is a (Continued)

(57) **ABSTRACT**

Improved methods and devices for performing an endoscopic surgery are provided. Systems are taught for operatively treating gastrointestinal disorders endoscopically in a stable, yet dynamic operative environment, and in a minimally-invasive manner. Such systems include, for example, an endoscopic surgical suite. The surgical suite can have a reversibly-expandable retractor that expands to provide a stable, operative environment within a subject. The expansion can be asymmetric around a stabilizer subsystem to maximize space for a tool and an endoscope to each be maneuvered independently to visualize a target tissue and treat the target tissue from outside the patient in a minimally invasive manner.

(51) **Int. Cl.**  
**A61B 1/32** (2006.01)  
**A61B 1/00** (2006.01)  
(Continued)

(52) **U.S. Cl.**  
CPC ..... **A61B 1/00085** (2013.01); **A61B 1/00087** (2013.01); **A61B 1/00154** (2013.01);  
(Continued)

**12 Claims, 20 Drawing Sheets**

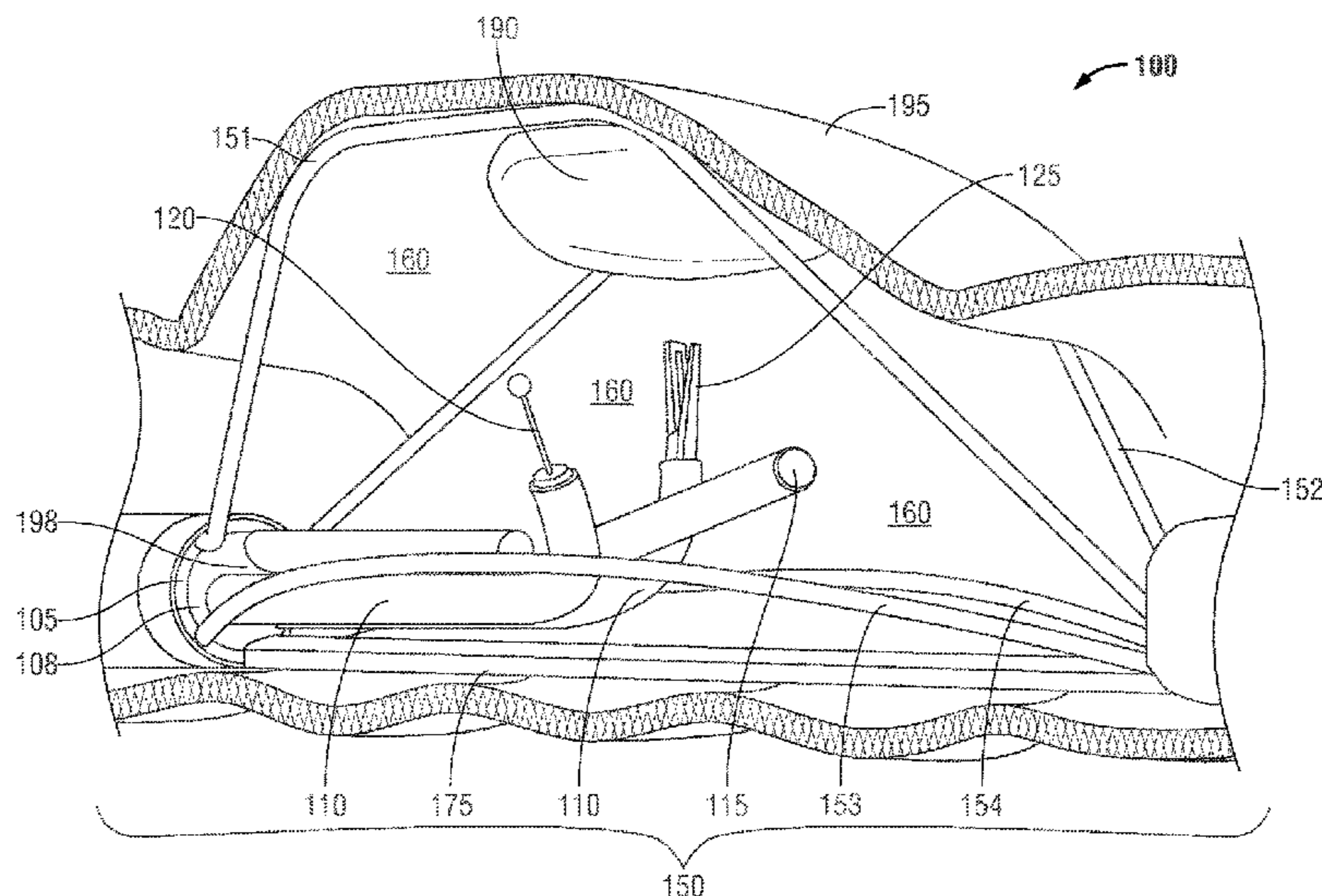

**Related U.S. Application Data**

continuation of application No. 13/531,477, filed on Jun. 22, 2012, now Pat. No. 8,932,211, and a continuation-in-part of application No. 12/970,604, filed on Dec. 16, 2010, now Pat. No. 8,506,479.

(60) Provisional application No. 61/287,077, filed on Dec. 16, 2009.

(51) **Int. Cl.**

- A61B 17/02* (2006.01)
- A61B 1/31* (2006.01)
- A61B 17/22* (2006.01)
- A61B 1/018* (2006.01)
- A61B 17/221* (2006.01)
- A61B 17/08* (2006.01)
- A61B 17/10* (2006.01)
- A61B 17/00* (2006.01)

(52) **U.S. Cl.**

CPC ..... *A61B 1/00183* (2013.01); *A61B 1/018* (2013.01); *A61B 1/31* (2013.01); *A61B 1/32* (2013.01); *A61B 17/0057* (2013.01); *A61B 17/00234* (2013.01); *A61B 17/0218* (2013.01); *A61B 17/08* (2013.01); *A61B 17/10* (2013.01); *A61B 17/22* (2013.01); *A61B 17/221* (2013.01)

(58) **Field of Classification Search**

USPC ..... 600/204, 205, 210, 221, 129, 114, 115  
See application file for complete search history.

(56) **References Cited**

U.S. PATENT DOCUMENTS

1,621,159 A	3/1927	Evans
2,072,346 A	3/1937	Smith
2,434,167 A	1/1948	Knoblauch
3,495,586 A	2/1970	Regenbogen
3,517,128 A	6/1970	Hines
3,557,794 A	1/1971	Van Patten
4,040,413 A	8/1977	Ohshiro
4,083,369 A	4/1978	Sinnreich
4,224,929 A	9/1980	Furihata
4,295,464 A	10/1981	Shihata
4,519,403 A	5/1985	Dickhudt
4,611,594 A	9/1986	Grayhack et al.
4,710,171 A	12/1987	Rosenberg
4,836,204 A	6/1989	Landymore et al.
4,966,596 A	10/1990	Kuntz et al.
5,025,778 A	6/1991	Silverstein
5,059,199 A	10/1991	Okada
5,087,265 A	2/1992	Summers
5,112,310 A	5/1992	Grobe
5,167,239 A	12/1992	Cohen et al.
5,197,971 A	3/1993	Bonutti
5,211,624 A	5/1993	Cinberg et al.
5,211,638 A	5/1993	Dudar et al.
5,386,817 A	2/1995	Jones
5,411,475 A	5/1995	Atala et al.
5,411,508 A	5/1995	Bessler et al.
5,423,830 A *	6/1995	Schneebaum ..... A61B 18/10 606/110
5,454,365 A	10/1995	Bonutti
5,655,698 A	8/1997	Yoon
5,709,657 A	1/1998	Zimmon
5,716,321 A	2/1998	Kerin et al.
5,722,103 A	3/1998	Walega
5,776,097 A	7/1998	Massoud
5,947,983 A	9/1999	Solar et al.
5,954,731 A	9/1999	Yoon
5,997,547 A	12/1999	Nakao et al.
6,009,877 A	1/2000	Edwards
6,042,596 A	3/2000	Bonutti
6,119,913 A	9/2000	Adams et al.

6,142,931 A	11/2000	Kaji
6,142,933 A	11/2000	Longo et al.
6,203,552 B1	3/2001	Bagley et al.
6,214,024 B1	4/2001	Houser
6,264,086 B1	7/2001	McGuckin
6,302,311 B1	10/2001	Adams et al.
6,343,731 B1	2/2002	Adams et al.
6,405,732 B1	6/2002	Edwards et al.
6,423,058 B1	7/2002	Edwards et al.
6,428,473 B1	8/2002	Leonard et al.
6,443,959 B1	9/2002	Beland et al.
6,494,881 B1	12/2002	Bales et al.
6,605,078 B2	8/2003	Adams
6,616,603 B1	9/2003	Fontana
6,695,198 B2	2/2004	Adams et al.
6,805,273 B2	10/2004	Bilotti et al.
6,808,491 B2	10/2004	Kortenbach et al.
6,840,423 B2	1/2005	Adams et al.
6,866,178 B2	3/2005	Adams et al.
6,874,669 B2	4/2005	Adams et al.
6,913,610 B2	7/2005	Nakao
6,923,806 B2	8/2005	Hooven et al.
6,938,814 B2	9/2005	Sharma et al.
7,014,646 B2	3/2006	Adams et al.
7,059,331 B2	6/2006	Adams et al.
7,063,659 B2	6/2006	Goto et al.
7,169,115 B2	1/2007	Nobis et al.
7,276,066 B2	10/2007	Ouchi
7,396,329 B2	7/2008	Nakao
7,445,598 B2	11/2008	Orban
7,918,787 B2	4/2011	Saadat
7,959,559 B2	6/2011	Yamaya
8,007,508 B2	8/2011	Cox
8,277,373 B2	10/2012	Maahs et al.
8,506,479 B2	8/2013	Piskun et al.
8,517,933 B2	8/2013	Mohr
8,608,652 B2	12/2013	Voegele et al.
8,764,630 B2	7/2014	Yamatani
8,777,961 B2	7/2014	Cabrera et al.
8,932,326 B2	1/2015	Riina et al.
8,979,884 B2	3/2015	Milsom et al.
9,039,601 B2	5/2015	Piskun
9,050,004 B2	6/2015	Diao et al.
9,161,746 B2	10/2015	Piskun et al.
9,168,053 B2	10/2015	Cox
9,259,233 B2	2/2016	Gruber et al.
9,370,379 B2	6/2016	Osman
9,375,224 B2	6/2016	Jansen
9,661,984 B2	5/2017	Piskun
2001/0004947 A1	6/2001	Lemke et al.
2001/0047169 A1	11/2001	McGuckin, Jr. et al.
2001/0049497 A1	12/2001	Kaloo et al.
2001/0056260 A1	12/2001	Grimes et al.
2002/0123748 A1	9/2002	Edwards et al.
2002/0183593 A1	12/2002	Chin et al.
2002/0193660 A1	12/2002	Weber et al.
2003/0023143 A1	1/2003	Abe et al.
2003/0050663 A1	3/2003	Khachin et al.
2003/0074015 A1	4/2003	Nakao
2003/0135230 A1	7/2003	Massey et al.
2003/0225432 A1	12/2003	Baptiste et al.
2003/0225433 A1	12/2003	Nakao
2004/0034278 A1	2/2004	Adams
2004/0082859 A1	4/2004	Schaer
2004/0158263 A1	8/2004	McAlister et al.
2004/0204725 A1	10/2004	Bayer
2004/0210116 A1	10/2004	Nakao
2004/0249367 A1	12/2004	Saadat et al.
2005/0177105 A1	8/2005	Shalev
2005/0234297 A1	10/2005	Devierre
2005/0234299 A1	10/2005	Eitenmuller et al.
2005/0240147 A1	10/2005	Makower et al.
2005/0251111 A1	11/2005	Saito et al.
2005/0251177 A1	11/2005	Saadat et al.
2005/0272977 A1	12/2005	Saadat et al.
2005/0273085 A1	12/2005	Hinman et al.
2006/0074277 A1	4/2006	Yoshida
2006/0100480 A1	5/2006	Ewers et al.
2006/0189845 A1	8/2006	Maahs et al.

(56)

References Cited

U.S. PATENT DOCUMENTS

2006/0191975 A1 8/2006 Adams et al.  
 2006/0247662 A1 11/2006 Schwartz  
 2006/0264706 A1 11/2006 Piskun  
 2007/0005093 A1 1/2007 Cox  
 2007/0021778 A1 1/2007 Carly  
 2007/0255207 A1 11/2007 Hangai et al.  
 2007/0287886 A1 12/2007 Saadat  
 2007/0287889 A1\* 12/2007 Mohr ..... A61B 1/00082  
 600/207  
 2007/0293724 A1 12/2007 Saadat et al.  
 2008/0045842 A1 2/2008 Furnish et al.  
 2008/0051629 A1 2/2008 Sugiyama et al.  
 2008/0058590 A1 3/2008 Saadat et al.  
 2008/0132835 A1 6/2008 Nagamatsu et al.  
 2008/0161645 A1 7/2008 Goldwasser et al.  
 2008/0188868 A1 8/2008 Weitzner et al.  
 2008/0228209 A1 9/2008 DeMello et al.  
 2008/0249534 A1 10/2008 Gruber et al.  
 2008/0262492 A1 10/2008 Lee  
 2008/0269557 A1 10/2008 Marescaux et al.  
 2008/0269559 A1 10/2008 Miyamoto et al.  
 2008/0275300 A1 11/2008 Rothe et al.  
 2008/0300454 A1 12/2008 Goto  
 2009/0018500 A1 1/2009 Carter et al.  
 2009/0030369 A1 1/2009 Nagamatsu et al.  
 2009/0149716 A1 6/2009 Diao et al. .... A61B 17/0206  
 600/202  
 2009/0156996 A1 6/2009 Milsom et al.  
 2009/0287046 A1 11/2009 Yamatani  
 2009/0312645 A1 12/2009 Weitzner et al.  
 2010/0010296 A1 1/2010 Piskun et al.  
 2010/0049137 A1 2/2010 Fischer, Jr.  
 2010/0106240 A1 4/2010 Duggal et al.  
 2010/0152590 A1 6/2010 Moore et al.  
 2011/0065985 A1 3/2011 Wehrheim  
 2011/0077498 A1 3/2011 McDaniel  
 2011/0160538 A1 6/2011 Ravikumar et al.  
 2011/0172491 A1 7/2011 Piskun et al.  
 2011/0224494 A1 9/2011 Piskun et al.  
 2011/0245858 A1 10/2011 Milsom et al.  
 2011/0306832 A1 12/2011 Bassan et al.  
 2012/0053485 A1 3/2012 Bloom  
 2012/0083797 A1 4/2012 Cabrera et al.  
 2012/0095498 A1 4/2012 Stefanchik et al.  
 2012/0109178 A1 5/2012 Edwards et al.  
 2012/0165604 A1 6/2012 Stokes et al.  
 2013/0090527 A1 4/2013 Axon  
 2013/0172828 A1 7/2013 Kappel et al.  
 2013/0192116 A1 8/2013 Elftmann, Jr.  
 2013/0274553 A1 10/2013 Piskun et al.  
 2013/0274556 A1 10/2013 Nearman et al.  
 2013/0317303 A1 11/2013 Deshmukh et al.  
 2013/0324795 A1 12/2013 Nakajima et al.  
 2014/0142393 A1 5/2014 Piskun et al.  
 2014/0316379 A1 10/2014 Sonderegger et al.  
 2015/0150436 A1 6/2015 Cornhill et al.  
 2015/0157192 A1 6/2015 Piskun et al.  
 2015/0265268 A1 9/2015 Diao et al.  
 2015/0265818 A1 9/2015 Piskun et al.  
 2015/0272564 A1 10/2015 Piskun et al.  
 2015/0351890 A1 12/2015 Levin et al.  
 2016/0038172 A1 2/2016 Cox  
 2016/0081702 A1 3/2016 Kan et al.  
 2016/0106466 A1 4/2016 Gruber et al.  
 2016/0157843 A1 6/2016 Dickson et al.  
 2016/0374658 A1 12/2016 Piskun

FOREIGN PATENT DOCUMENTS

CN 100452044 C 1/2009  
 CN 100462044 C 2/2009  
 CN 201200436 3/2009  
 CN 201200436 Y 3/2009  
 CN 102018493 A 4/2011

CN 102695541 A 9/2012  
 CN 103340679 A 10/2013  
 CN 104135972 A 11/2014  
 EP 0163502 A2 12/1985  
 EP 1588670 A1 10/2005  
 EP 2512577 A2 10/2012  
 GB 2365340 2/2002  
 GB 2365340 A 2/2002  
 JP S63292935 A 11/1988  
 JP H08317928 A 12/1996  
 JP H08336538 A 12/1996  
 JP 2533732 4/1997  
 JP 2533732 Y2 4/1997  
 JP H1028691 A 2/1998  
 JP 2000166936 A 6/2000  
 JP 2000-325303 11/2000  
 JP 2000325303 A 11/2000  
 JP 2001527429 A 12/2001  
 JP 2004154485 A 6/2004  
 JP 2004529708 A 9/2004  
 JP 2005/046274 2/2005  
 JP 2005046274 A 2/2005  
 JP 2007511247 A 5/2007  
 JP 2008528239 A 7/2008  
 JP 2008536552 A 9/2008  
 JP 2009523054 A 6/2009  
 JP 2009279406 A 12/2009  
 JP 2010511440 A 4/2010  
 JP 2011072782 A 4/2011  
 JP 2012075908 A 4/2012  
 JP 2013514827 A 5/2013  
 JP 2015000280 A 1/2015  
 JP 2015525109 A 9/2015  
 WO 9101773 A1 2/1991  
 WO 9501751 A1 1/1995  
 WO 9635469 A1 11/1996  
 WO 9635469 11/1996  
 WO 9640347 A1 12/1996  
 WO 0160284 A1 8/2001  
 WO 03000139 A1 1/2003  
 WO 2004103430 A2 12/2004  
 WO 2006110275 A2 10/2006  
 WO 2007081601 A2 7/2007  
 WO 2008011163 A2 1/2008  
 WO 2009059296 A1 5/2009  
 WO WO2009/059296 5/2009  
 WO 2009076176 A1 6/2009  
 WO 2009117696 A1 9/2009  
 WO WO 2009/117696 9/2009  
 WO 2011084616 A2 7/2011  
 WO WO 2011/084616 7/2011  
 WO 2012068048 A1 5/2012  
 WO 2012114569 A1 8/2012  
 WO 2013050880 A2 4/2013  
 WO 2013192116 A1 12/2013  
 WO WO 2013/192116 12/2013  
 WO 2014164661 A1 10/2014  
 WO 2014200737 A1 12/2014  
 WO 2015026968 A1 2/2015  
 WO 2015191125 A1 12/2015

OTHER PUBLICATIONS

“Oleg Shikhman vs. Bobcat Endoscopy, LLC (F/K/A/ LumenR LLC) and Gregory Piskun, M.D. Reply to Affirmative Defenses, Matters in Avoidance and Answer to Counterclaims”, Docket No. X03-HHD-CV17-6087023-S, dated Dec. 12, 2018, 19 pages.  
 “Oleg Shikhman vs. Bobcat Endoscopy, LLC (F/K/A/ LumenR LLC) and Gregory Piskun, M.D., Answer, Special Defenses and Counterclaims”, Docket No. HHD-CV-608 7023-S, dated Sep. 13, 2018, 23 pages.  
 “Oleg Shikhman vs. Bobcat Endoscopy, LLC (F/K/A/ LumenR LLC) and Gregory Piskun, M.D., First Amended Answer, Affirmative Defenses and Counterclaims”, Docket No. X03-HHD-CV17-6087023-S, dated Nov. 9, 2018, 24 pages.  
 “Letter from Jeffrey M. Chamberlain, Senior Principal at Kacvinsky Daisak Bluni pllc to Michael J. Rye, Esq. c/o Cantor Colburn, LLP”, dated Nov. 13, 2018, 3 pages.

(56)

**References Cited**

## OTHER PUBLICATIONS

“Letter from Michael J. Rye, Partner at Cantor Colburn LLP to Michael Mahoney, CEO at Boston Scientific Corporation”, dated Oct. 17, 2017, 3 pages.

Letter from Michael J. Rye, Partner at Cantor Colburn LLP to Jeffrey M. Chamberlain at Kacvinsky Daisak Bluni PLLC, dated Aug. 28, 2018, 2 pages.

European Communication for European Patent Application No. 14733912.1, dated Jun. 11, 2018, 2 pages.

European Search Report for the European Patent Application No. EP19214960, dated Apr. 17, 2020, 6 pages.

International Search Report and Written Opinion dated May 6, 2016 for International Application No. PCT/US2016/016911, 9 pages.

International Search Report and Written Opinion for application No. PCT/US2014/040429, dated Aug. 1, 2014, 11 pages.

International Search Report and Written Opinion dated Jun. 20, 2007 for International Application No. PCT/US06/30464, 6 pages.

International Search Report and Written Opinion for International Application No. PCT/US2013/046200, dated Sep. 23, 2013, 11 pages.

International Search Report and Written Opinion dated Dec. 14, 2017, for PCT/US2017/050685, 14 pages.

International Search Report and Written Opinion for International Application No. PCT/US17/68991, dated May 9, 2018, 11 pages.

International Search Report and Written Opinion for International Application No. PCT/US2016/031355, dated Sep. 23, 2016, 17 pages.

International Search Report and Written Opinion for International Application No. PCT/US18/14388, dated Jun. 19, 2018, 9 pages.

International Search Report and Written Opinion for PCT/US10/60802, dated Aug. 24, 2011, 12 pages.

International Search Report and Written Opinion for International Application No. PCT/US18/21779, dated Jun. 14, 2018, 10 pages.  
“*Sergey Kantsevov v. LumenR LLC*, Dr. Sergey Kantsevov’s Answer to LumenR LLC’s Counterclaims”, Civil Action No. 17-359 (ELH), filed Mar. 17, 2017, 8 pages.

“*Sergey Kantsevov vs. LumenR LLC*, Answer, Affirmative Defenses and Counterclaims”, Civil Action No. 17-CV-359 (ELH), filed Feb. 28, 2017, 25 pages.

“Letter from Kurt W. Lockwood, Principal at Kacvinsky Daisak Bluni pllc, to Philip G. Hampton, II c/o Haynes and Boone, LLP” dated Nov. 9, 2018, 16 pages.

“Letter from Philip G. Hampton, II at Haynes and Boone, LLP to Kurt W. Lockwood, Esq. at Kacvinsky Daisak Bluni PLLC”, dated Nov. 16, 2018, 2 pages.

“*Sergey Kantsevov v. LumenR LLC* Complaint, Civil Action No. 17-359”, filed Feb. 7, 2017, 18 pages.

*Oleg Shikhman v. Bobcat Endscopy LLC, et al.*, Memorandum of Decision, filed Oct. 31, 2019, 22 pages. (p. 1, line 15-p. 2, line 3; p. 2, lines 7-8, p. 7, lines 4-6; p. 8, lines 3-13; p. 10, line 4-p. 11, line 9; p. 18, line 5-p. 19, line 2; p. 18. footnote 15.).

European Search Report for the European Patent Application No. EP20151480, dated Jul. 10, 2020, 9 pages.

International Search Report and Written Opinion for the International Patent Application No. PCT/US2020/063710, dated Mar. 30, 2021, 15 pages.

European Search Report dated Jun. 1, 2014 for International Application No. PCT/US2014/040429.

European Search Report dated May 3, 2011 for European Patent Application No. 06789411.3.

Written Opinion dated Jun. 20, 2007 for International Application No. PCT/US06/30464.

Chinese Office Action dated May 12, 2009 for Chinese Application No. 200680028706.2.

\* cited by examiner



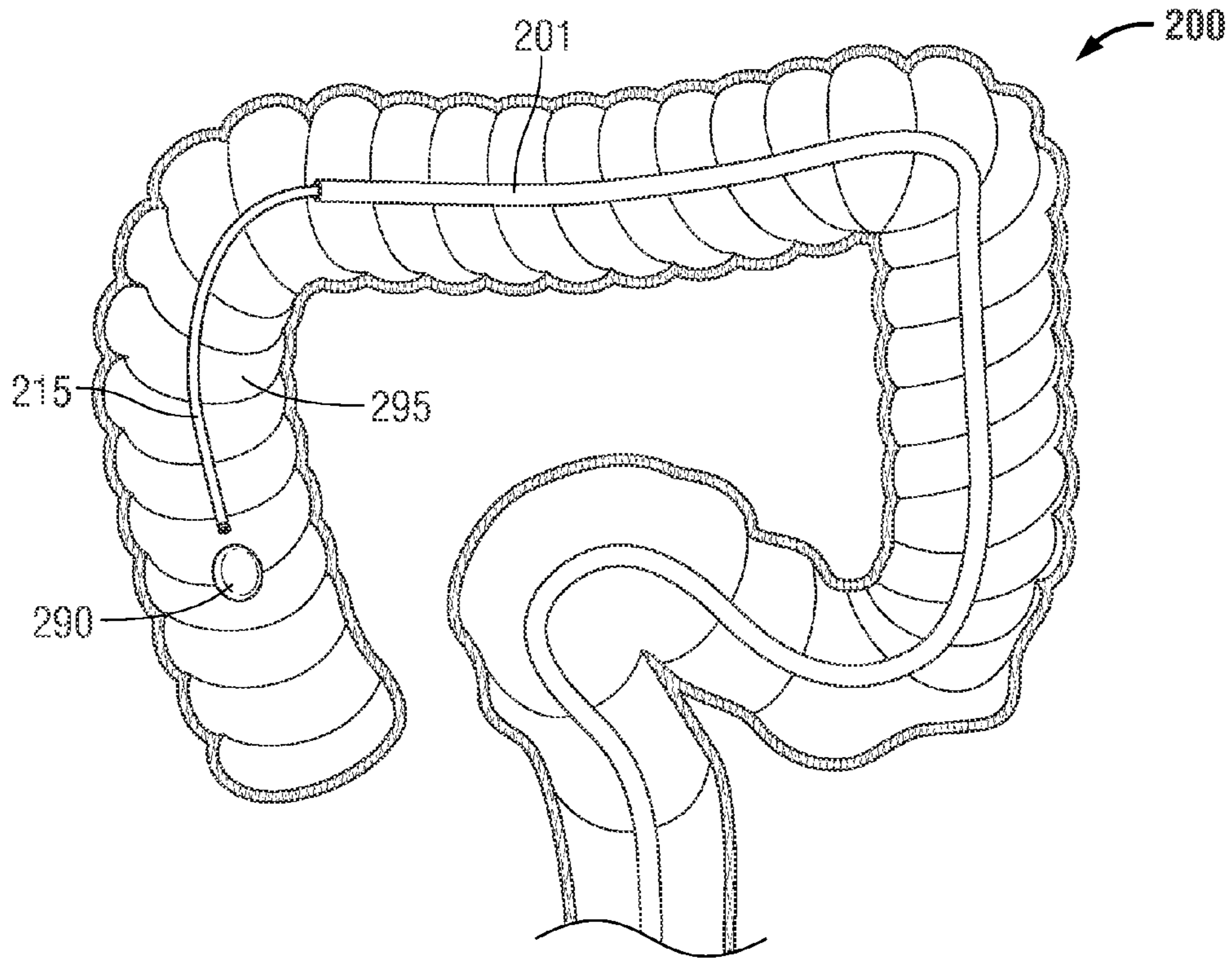

FIG. 2A

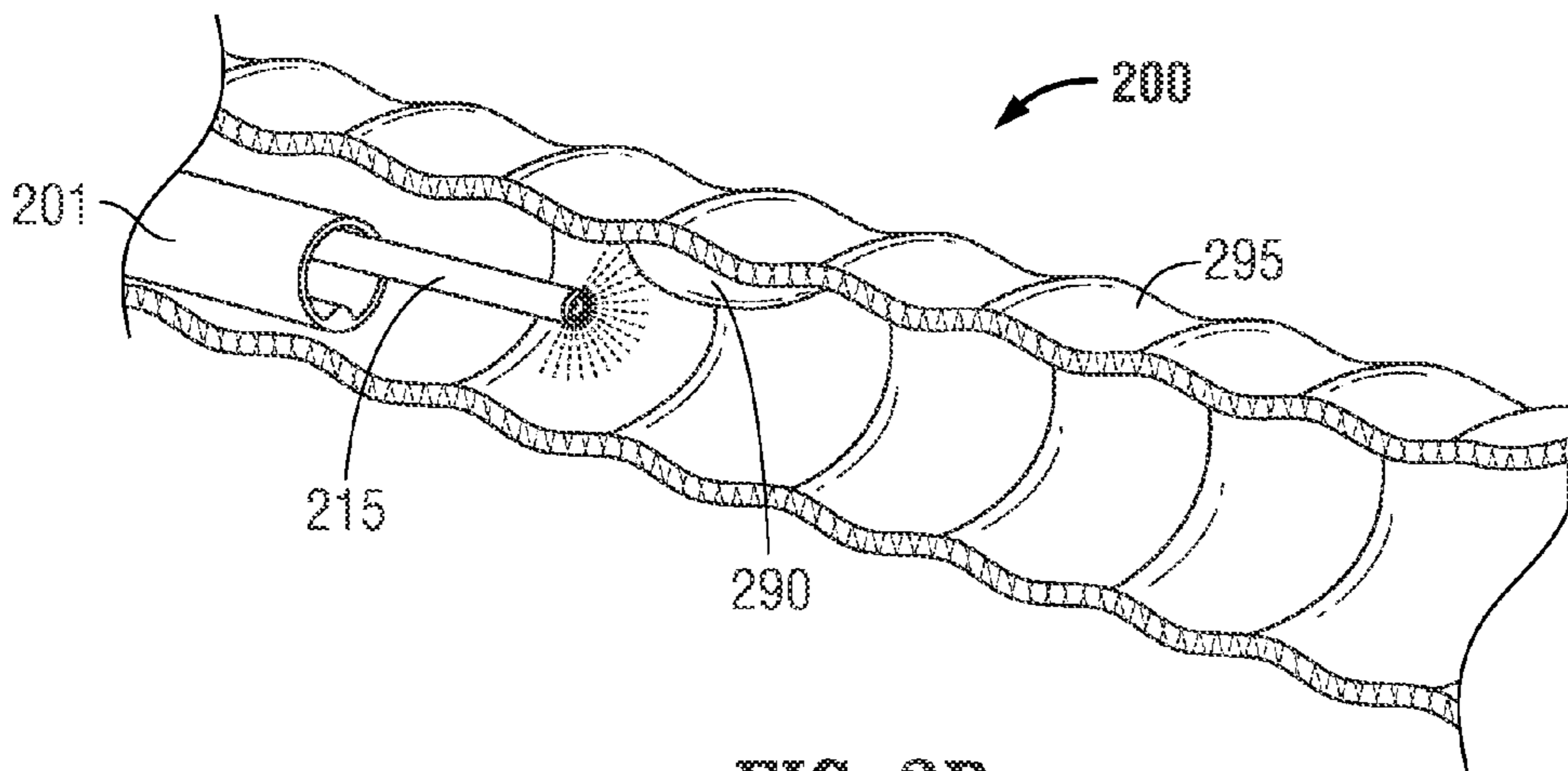

FIG. 2B

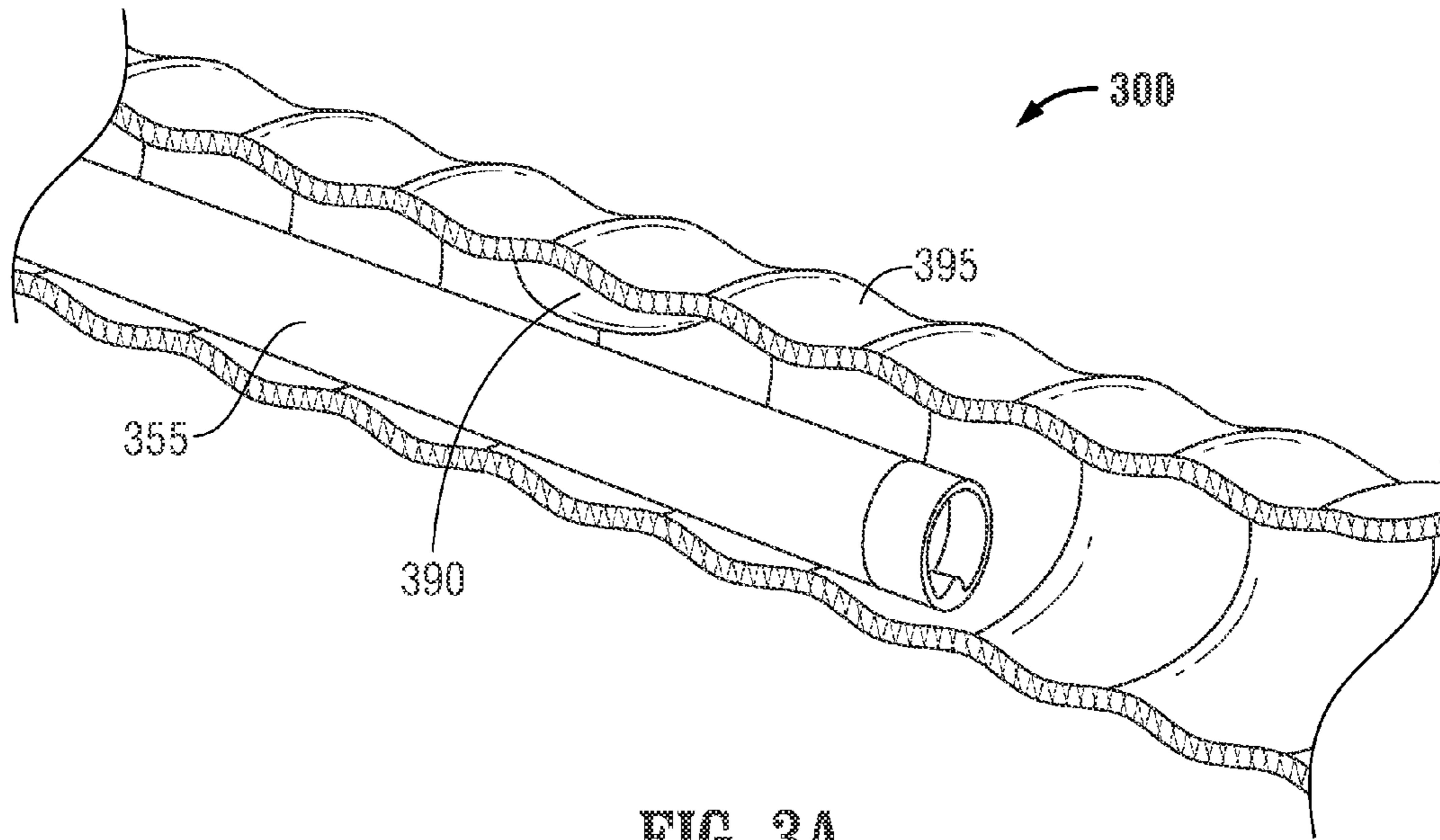

FIG. 3A

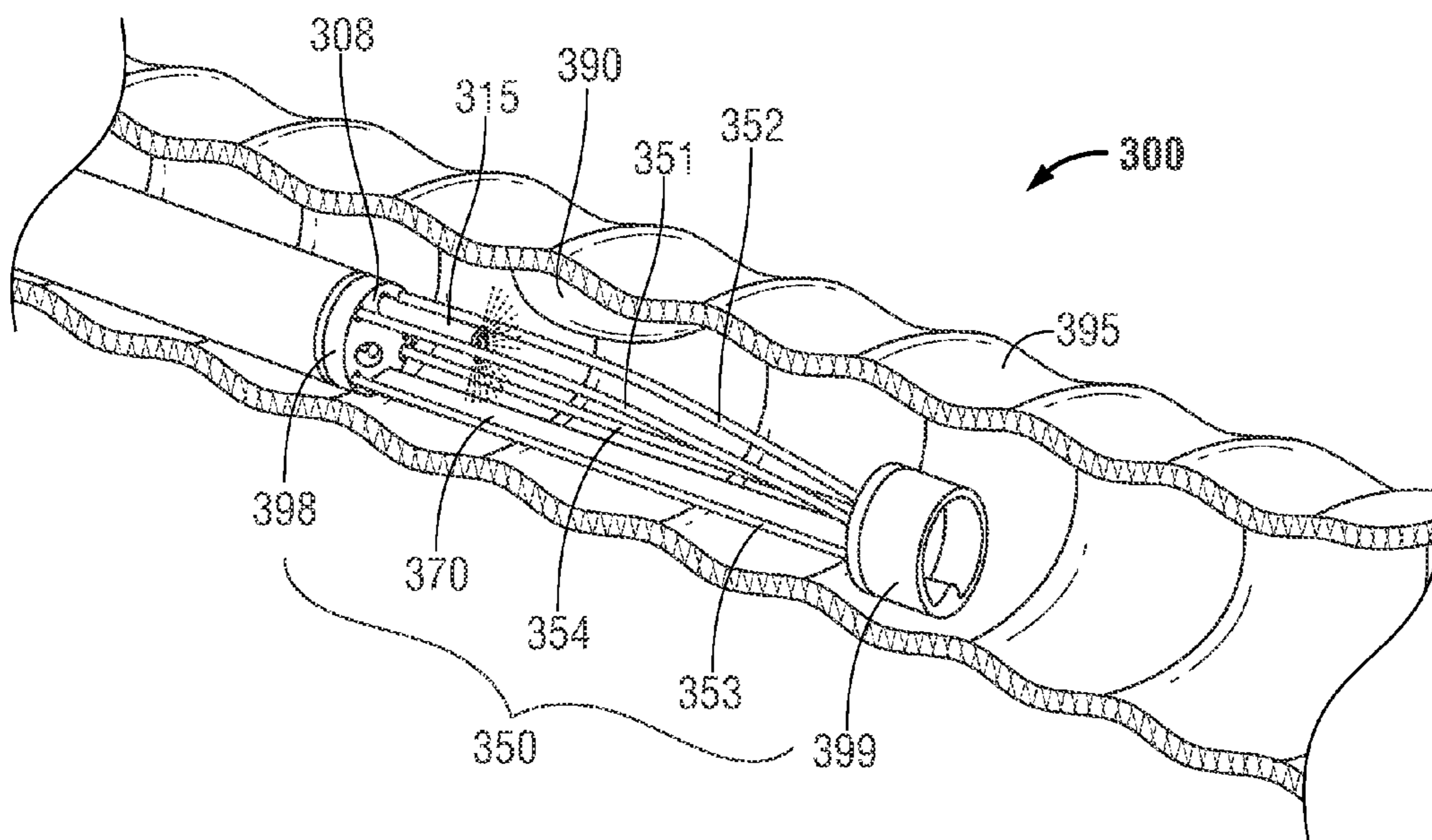

FIG. 3B

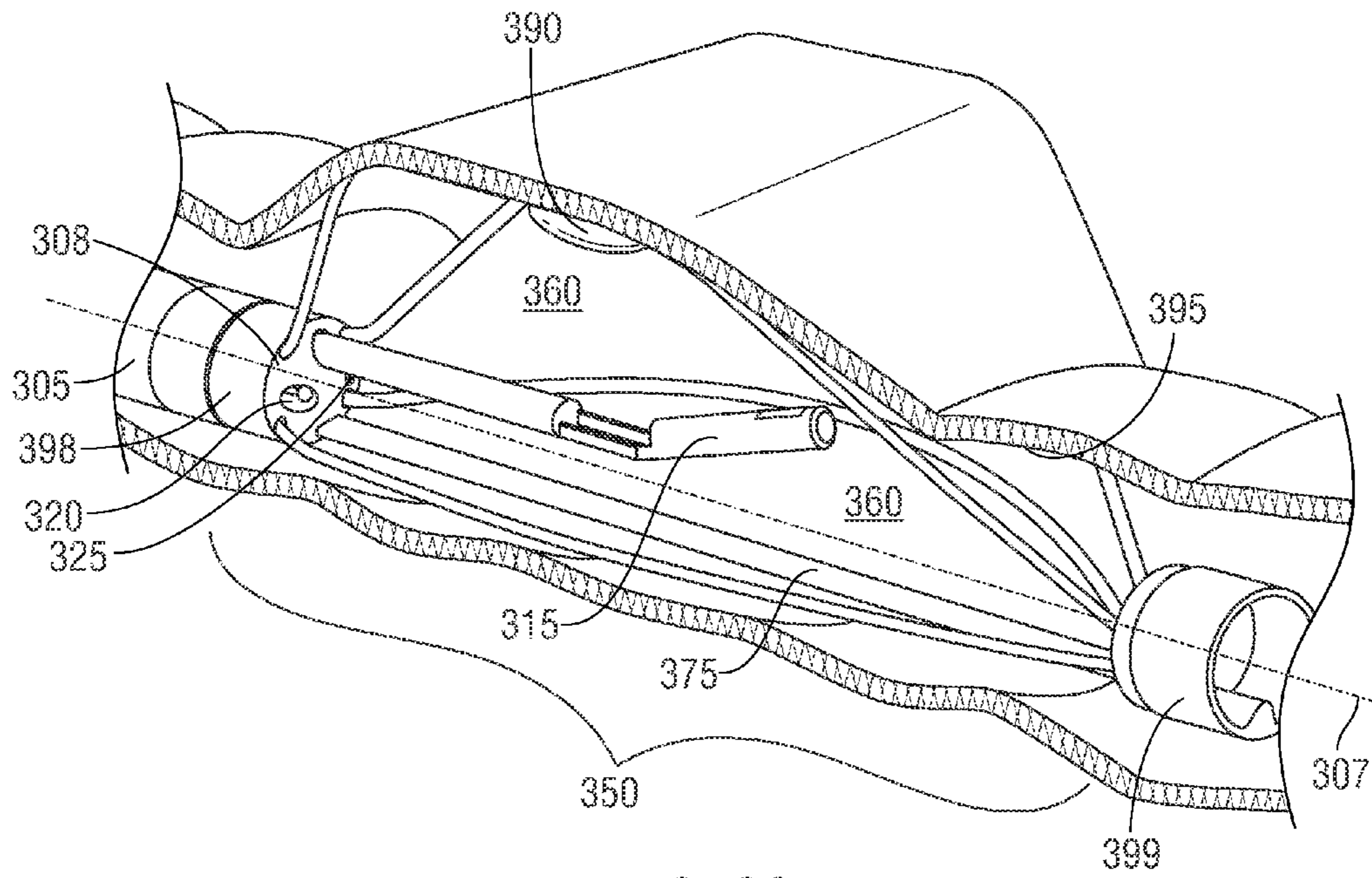

FIG. 3C

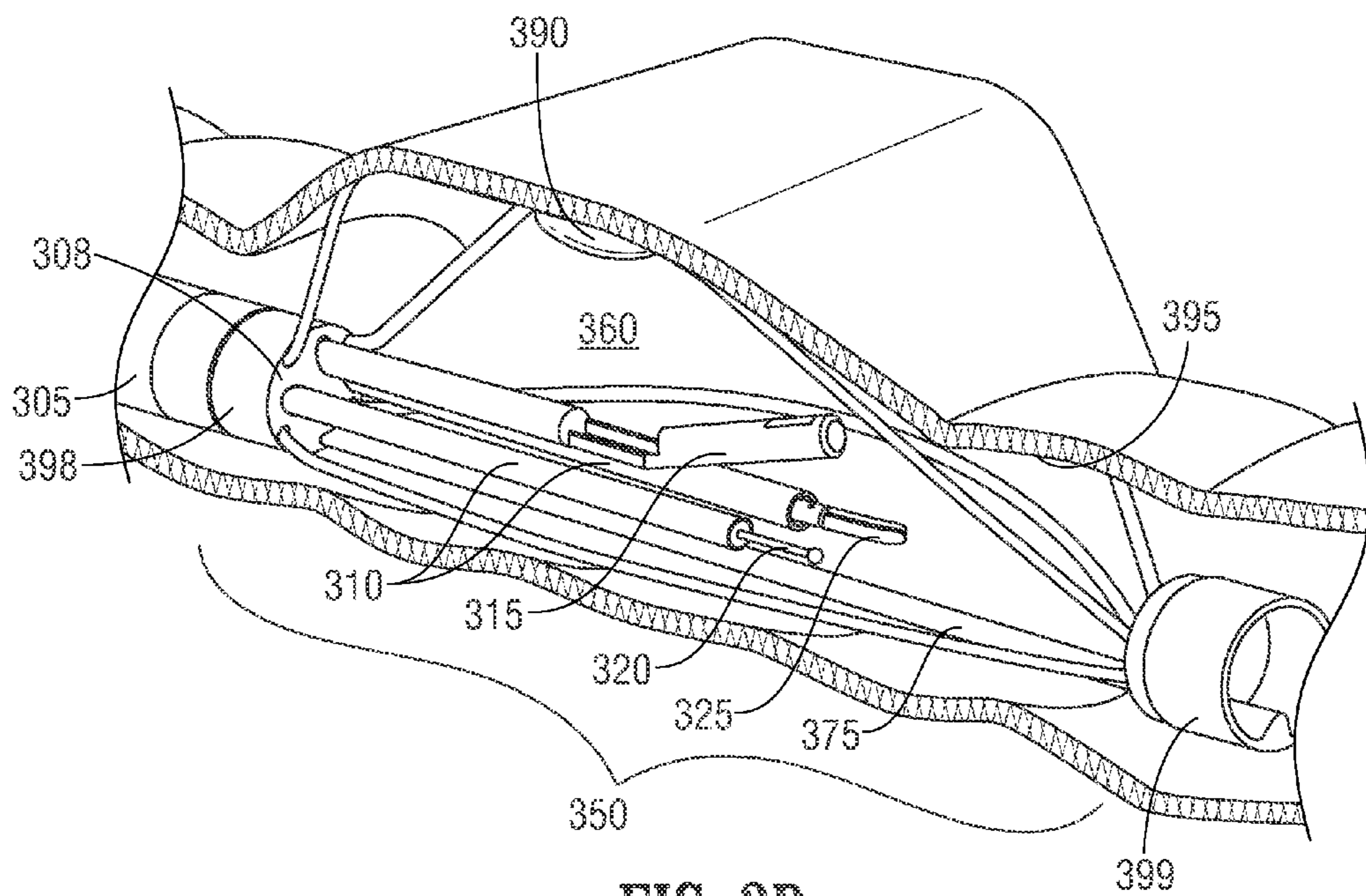

FIG. 3D



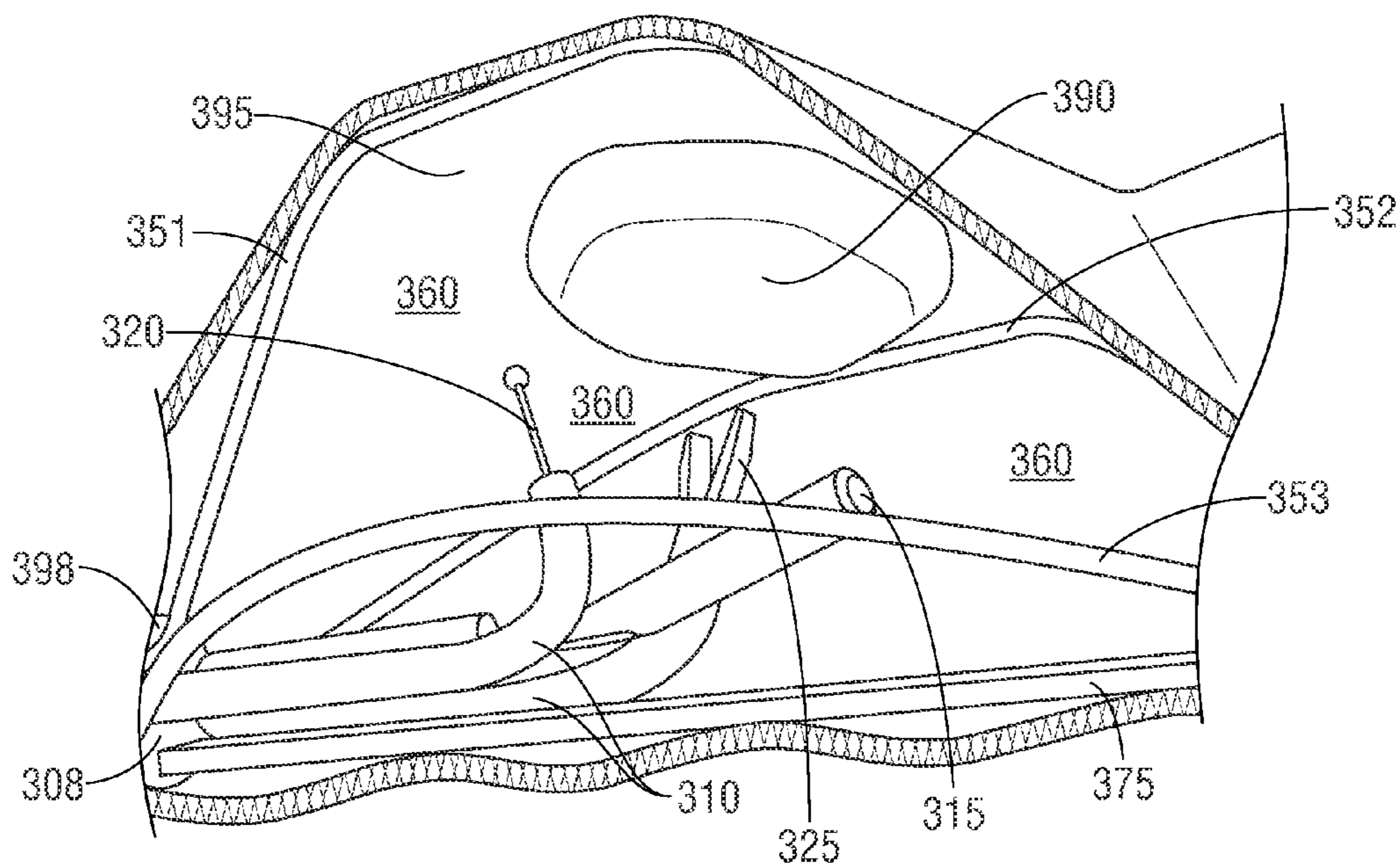

FIG. 3E

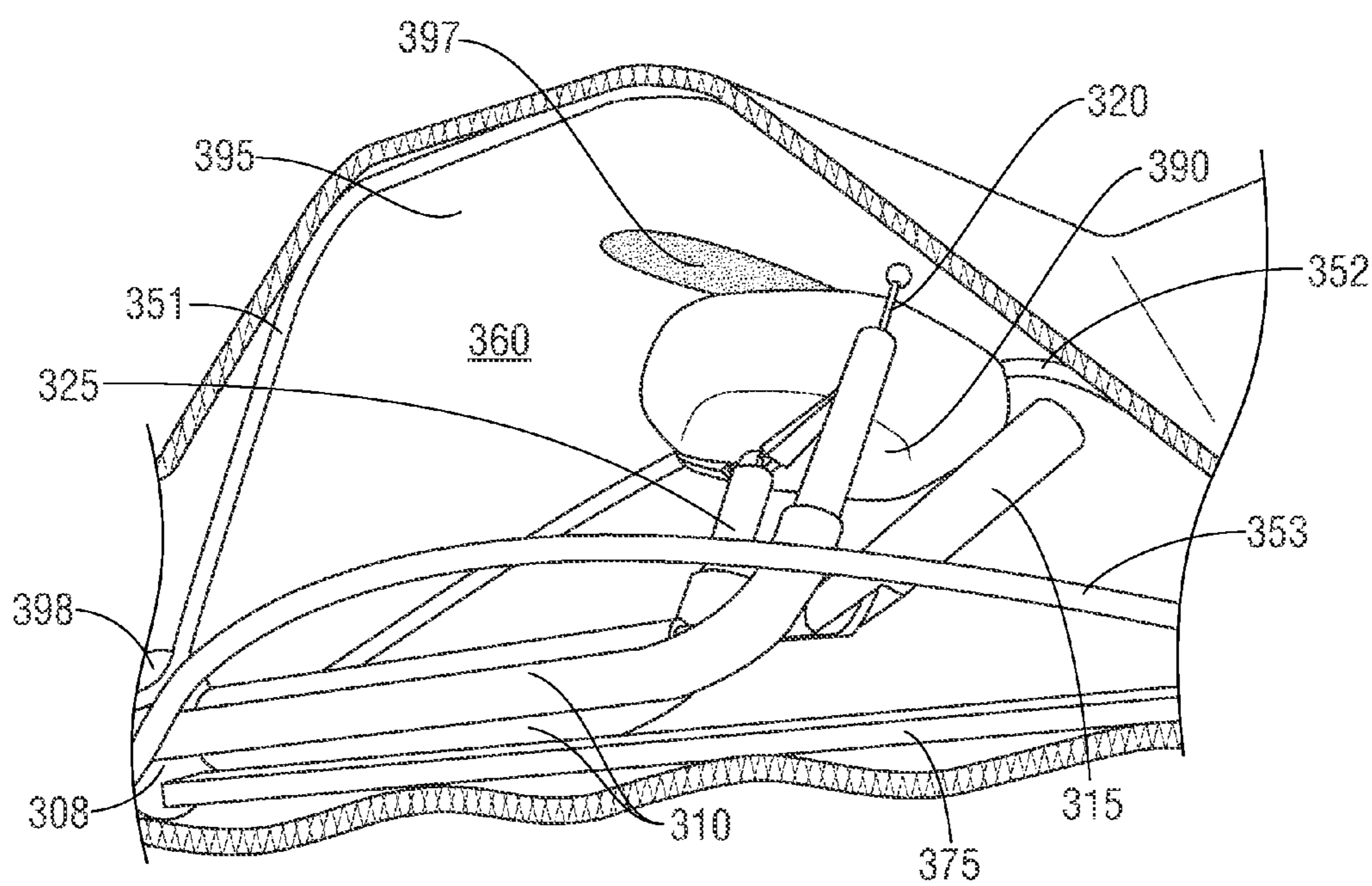

FIG. 3F

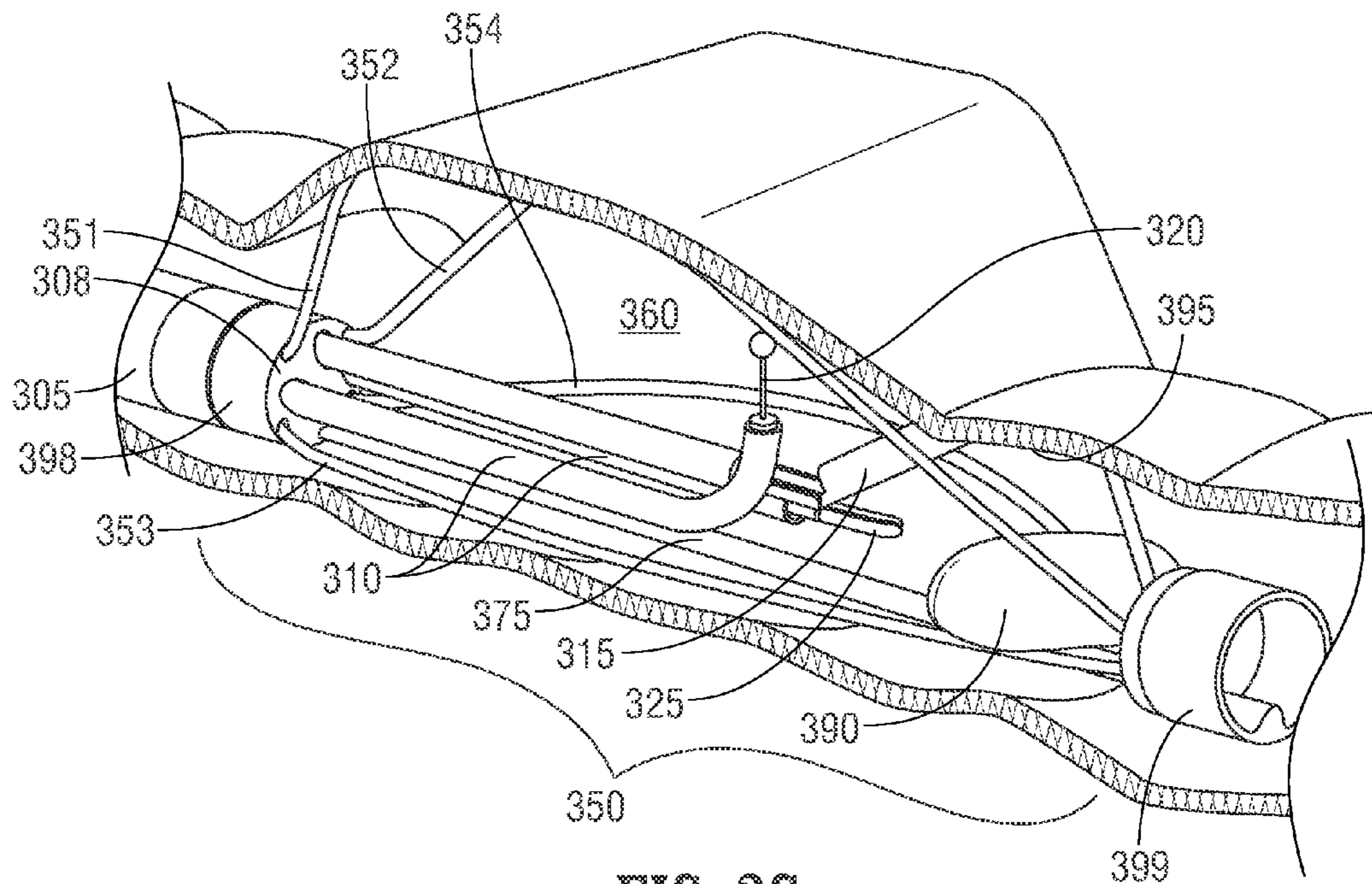

FIG. 3G

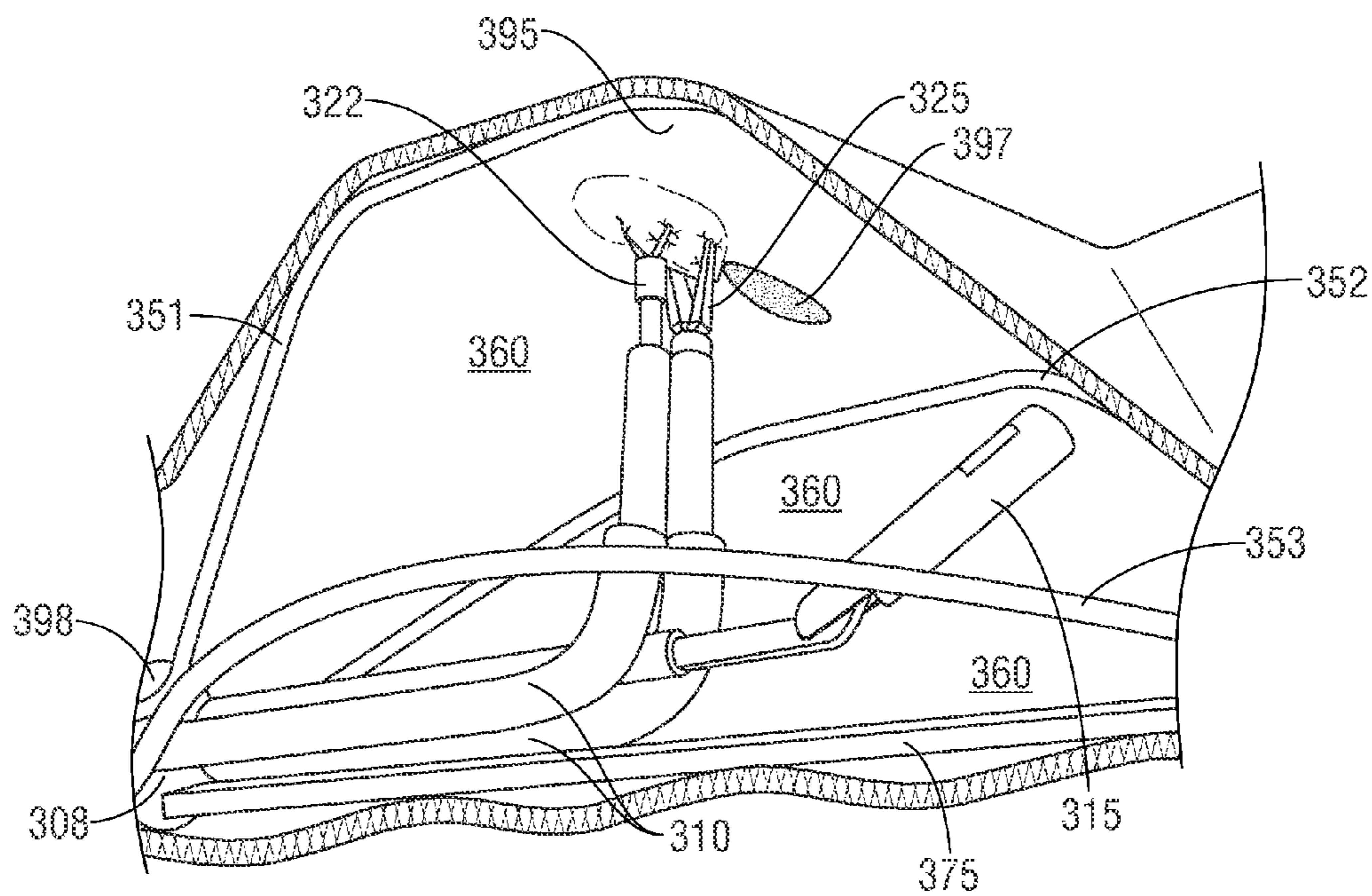

FIG. 3H

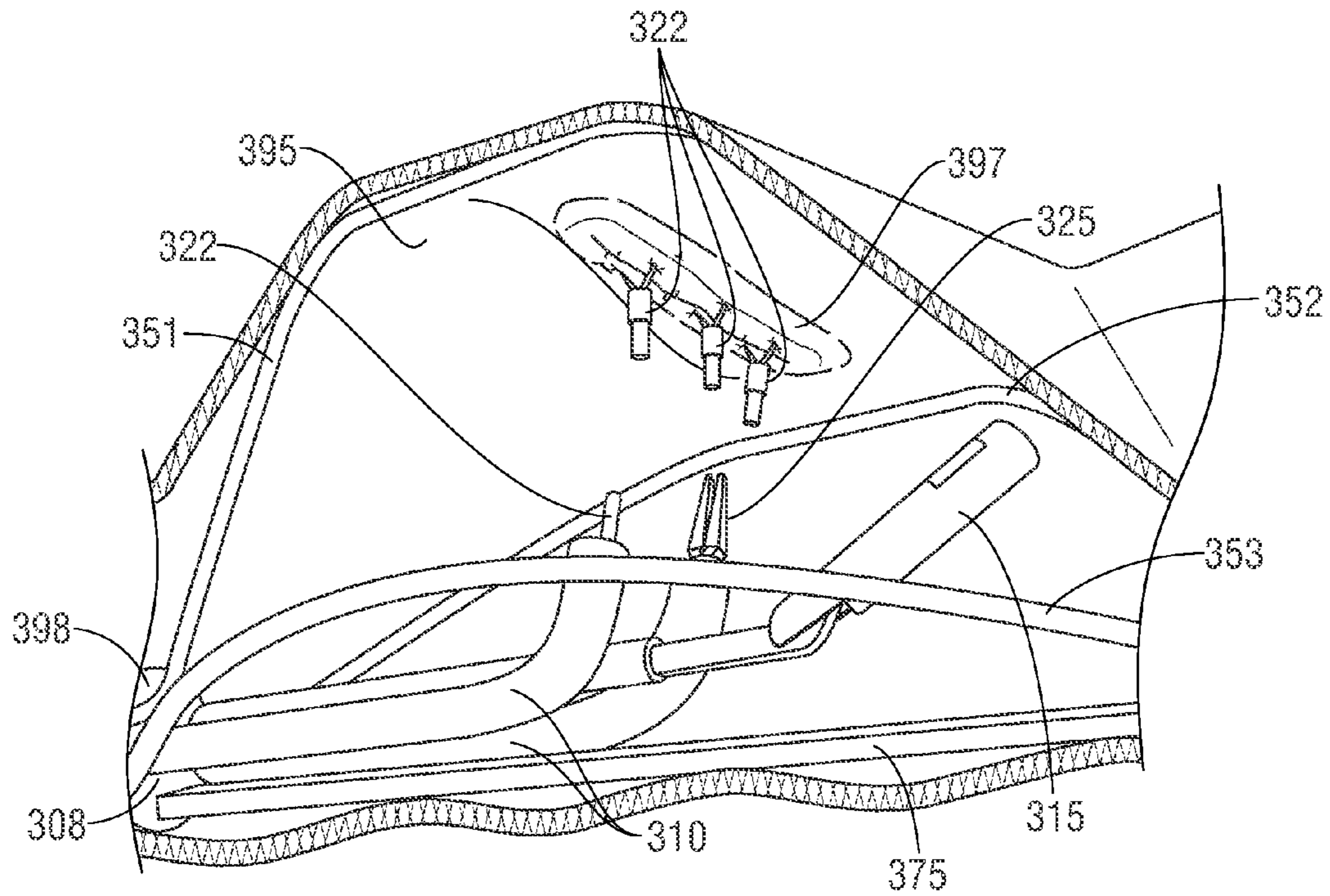

FIG. 3I

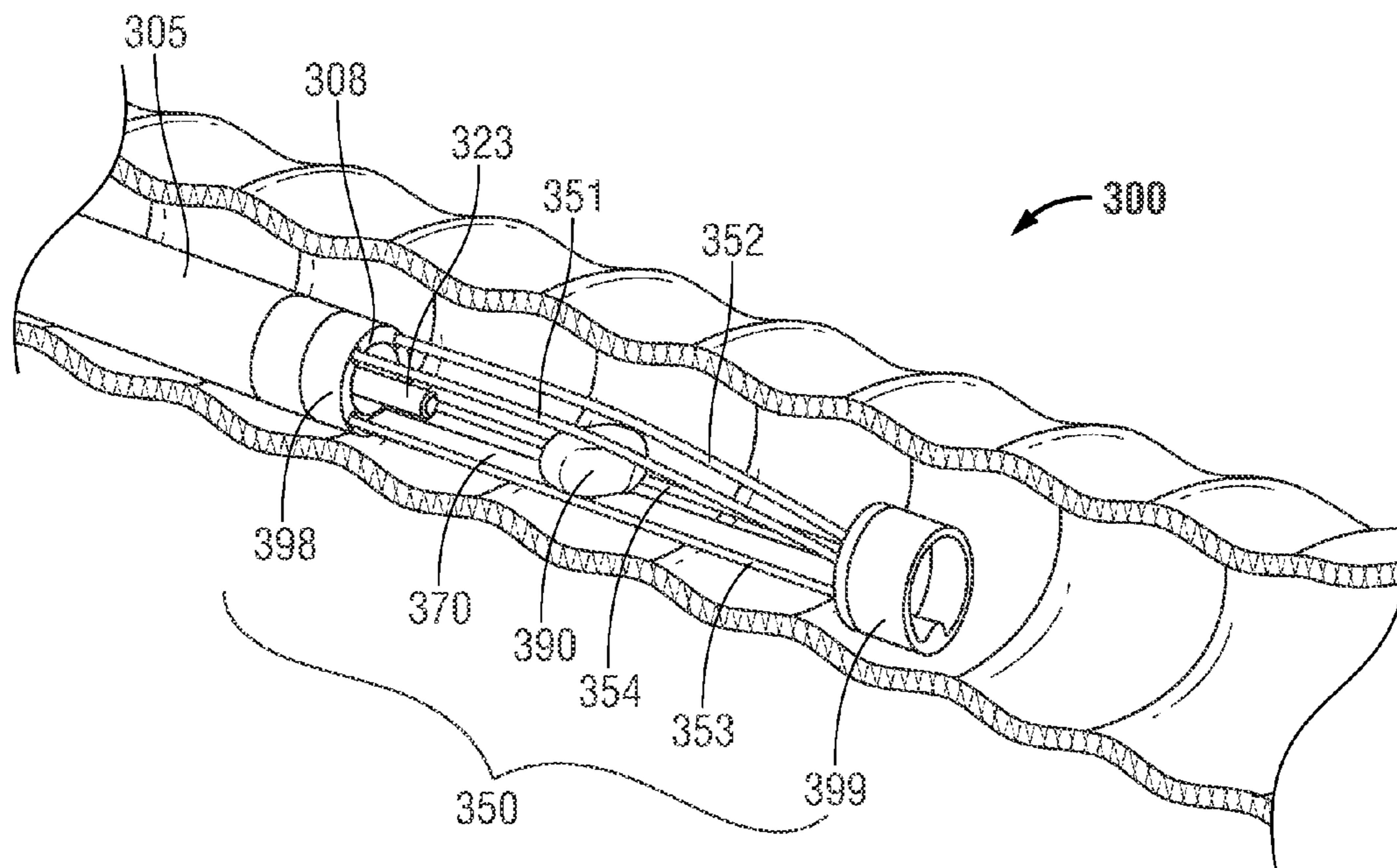

FIG. 3J

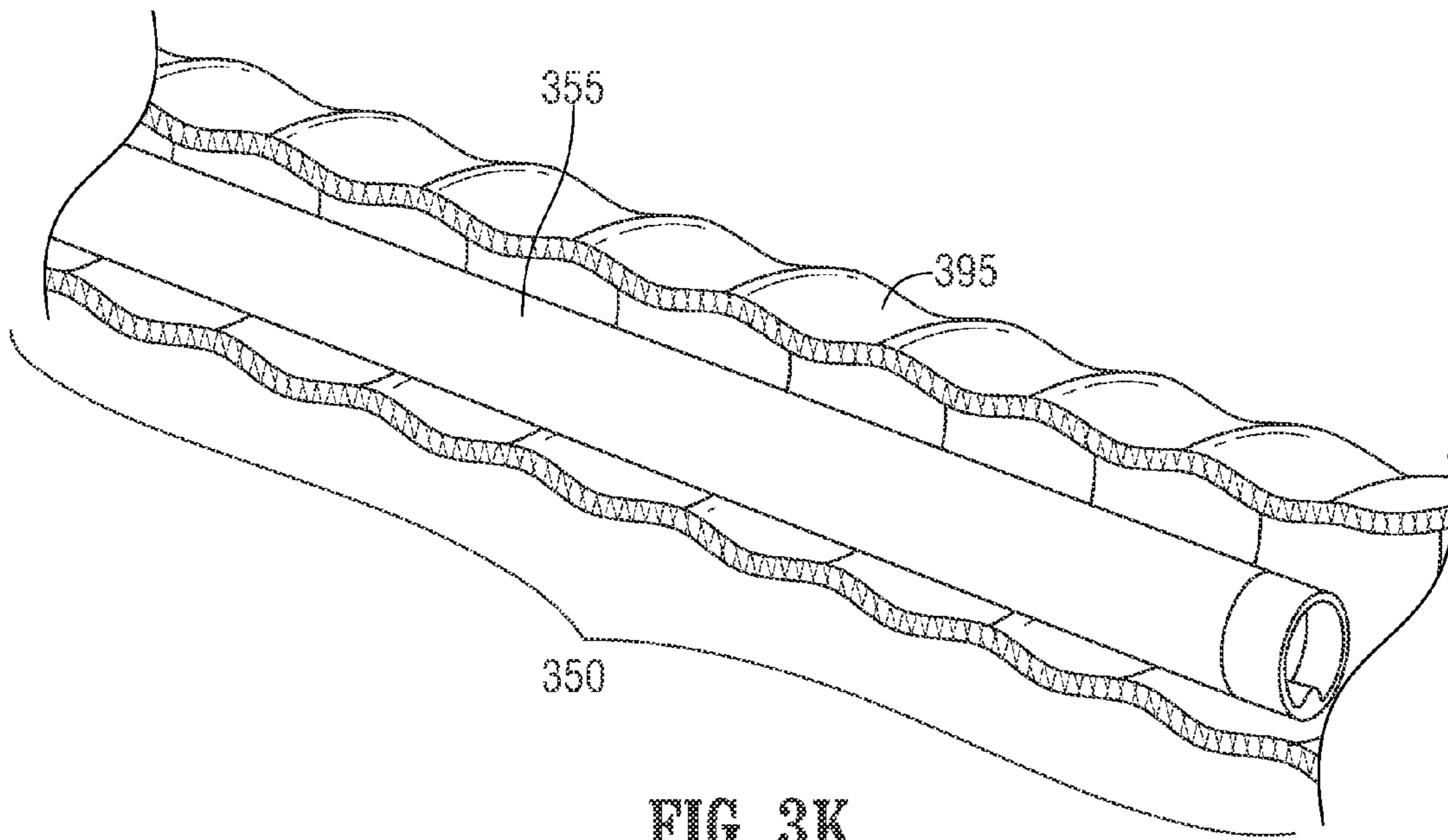

FIG. 3K

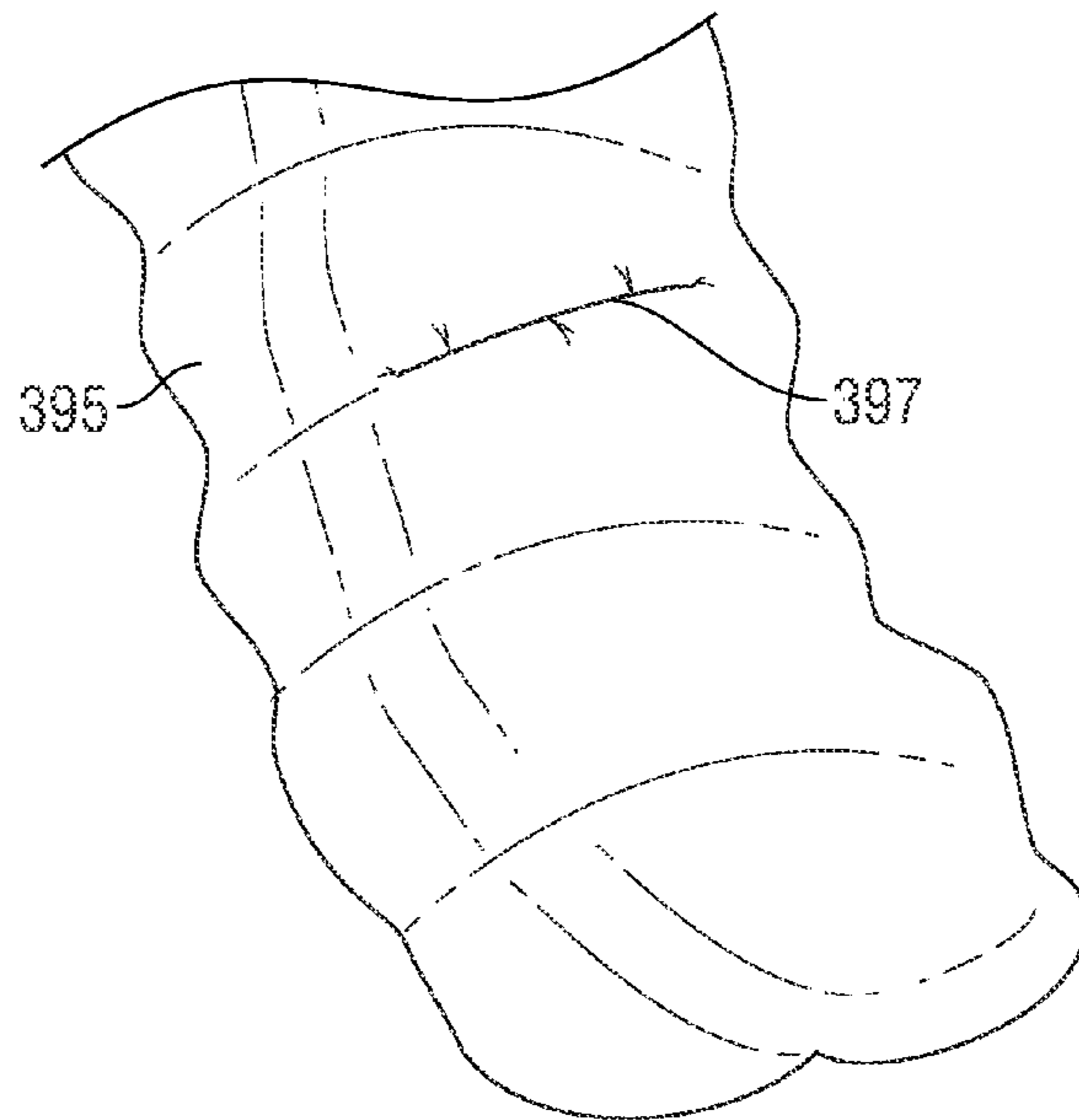

FIG. 3L

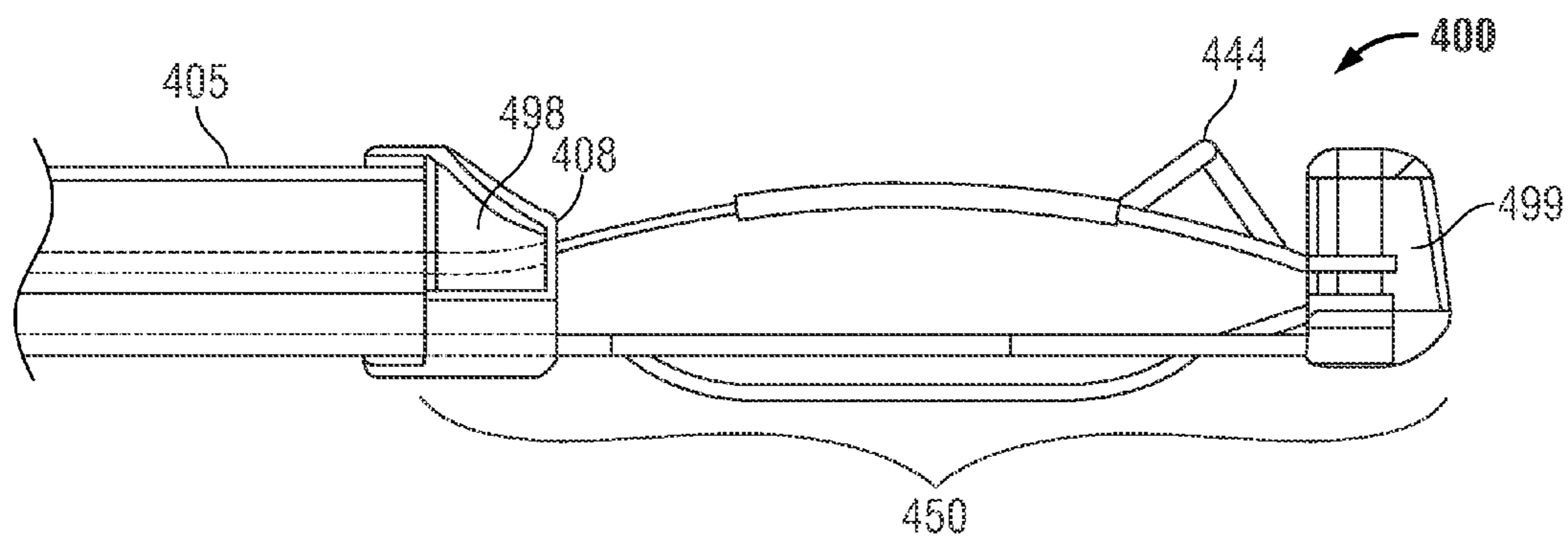

FIG. 4A

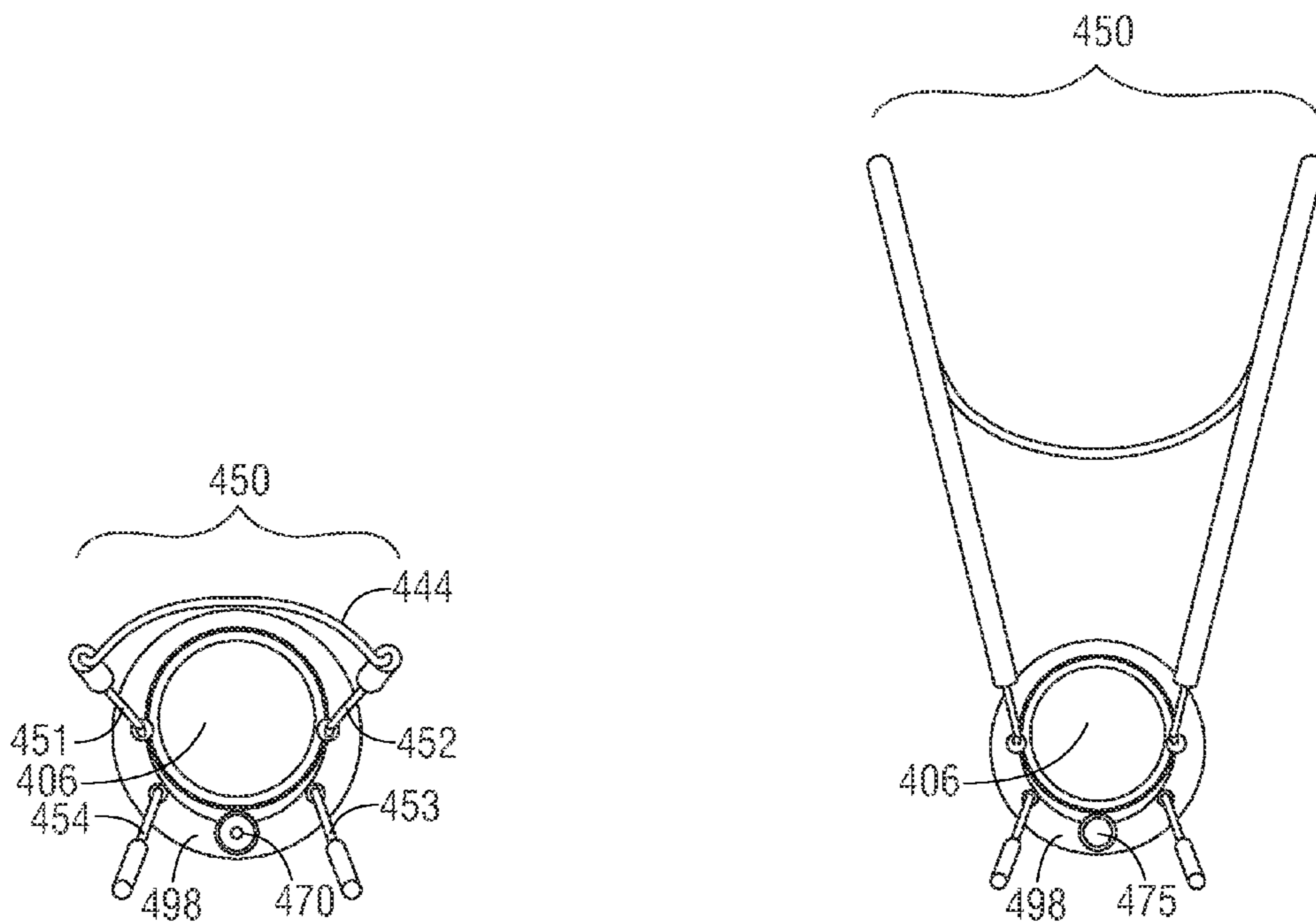

FIG. 4B

FIG. 4C

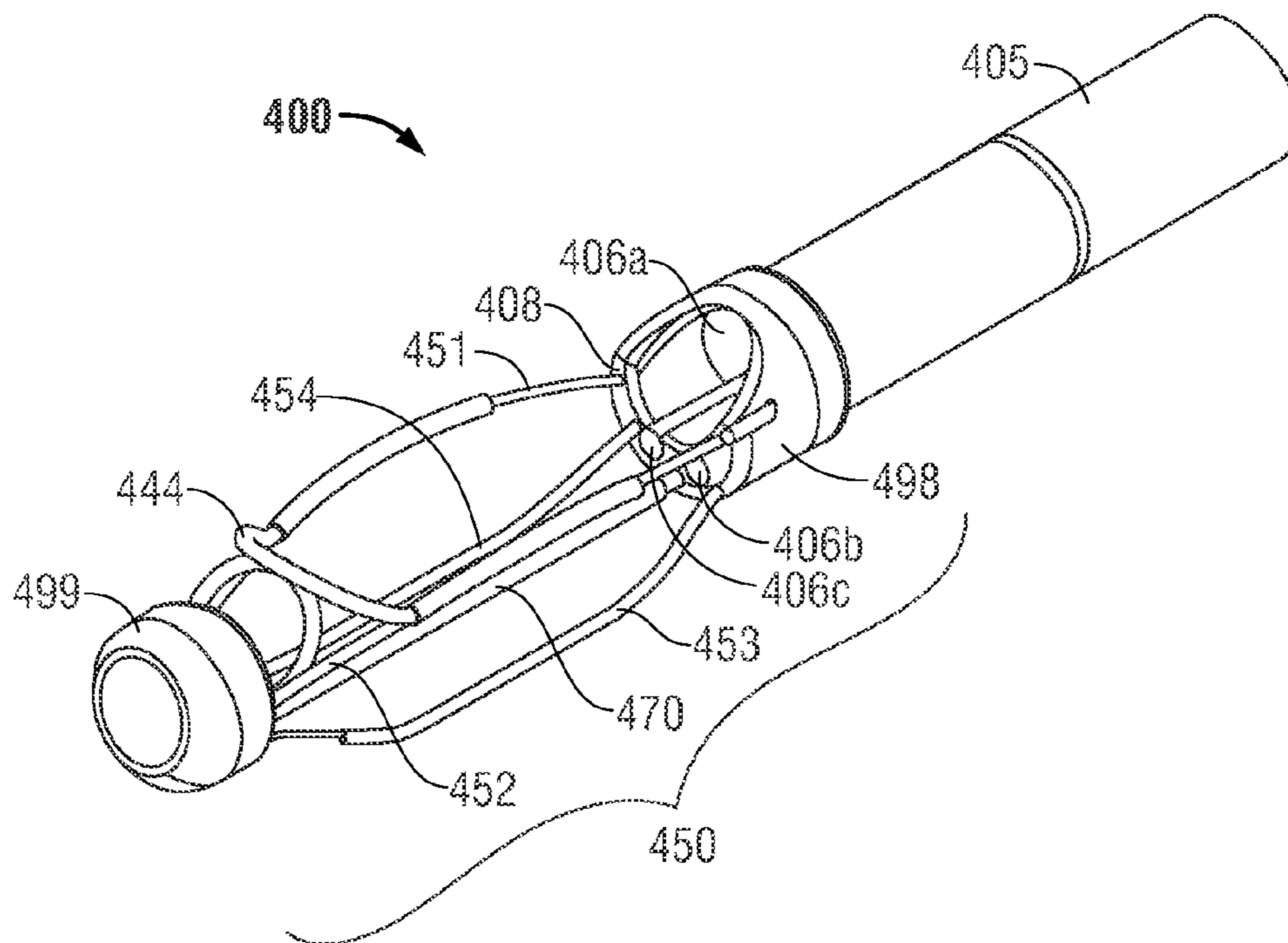

FIG. 4D

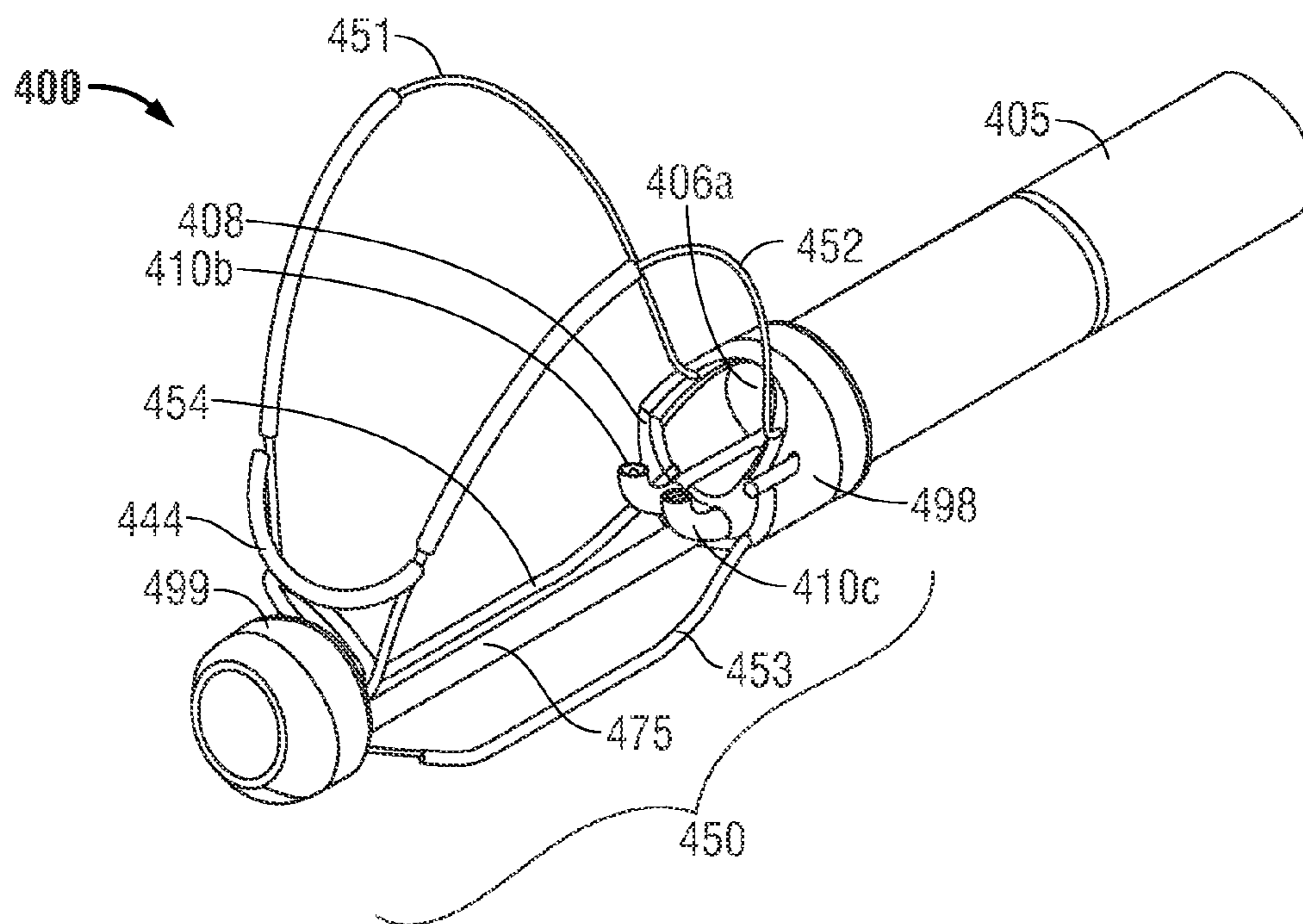

FIG. 4E

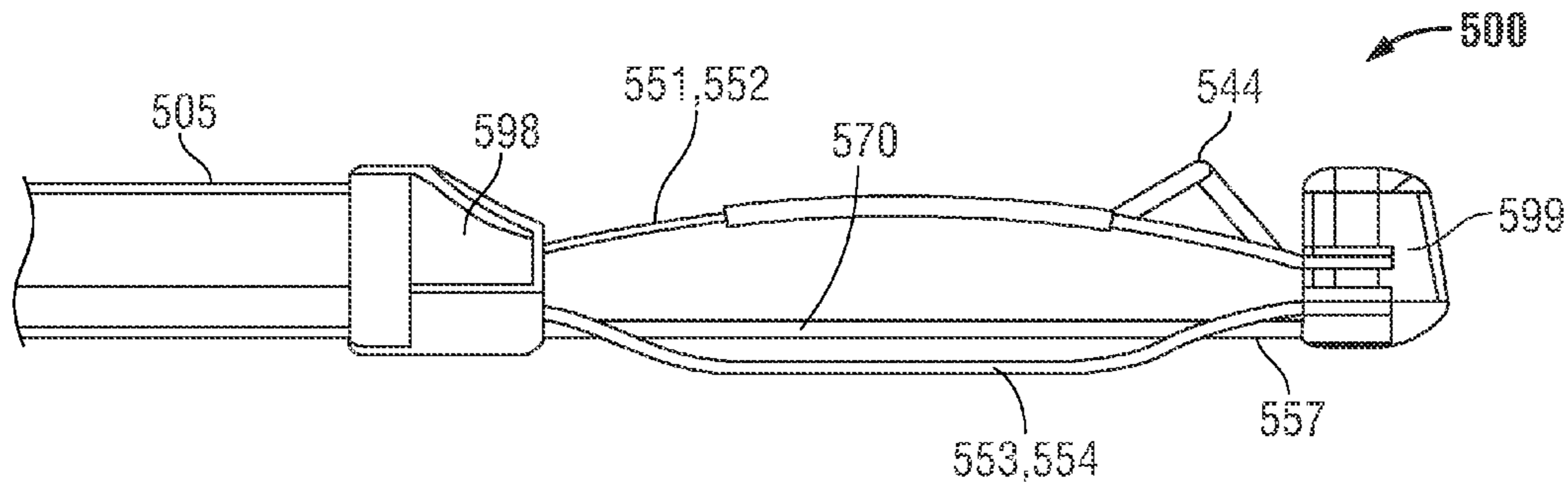

FIG. 5A

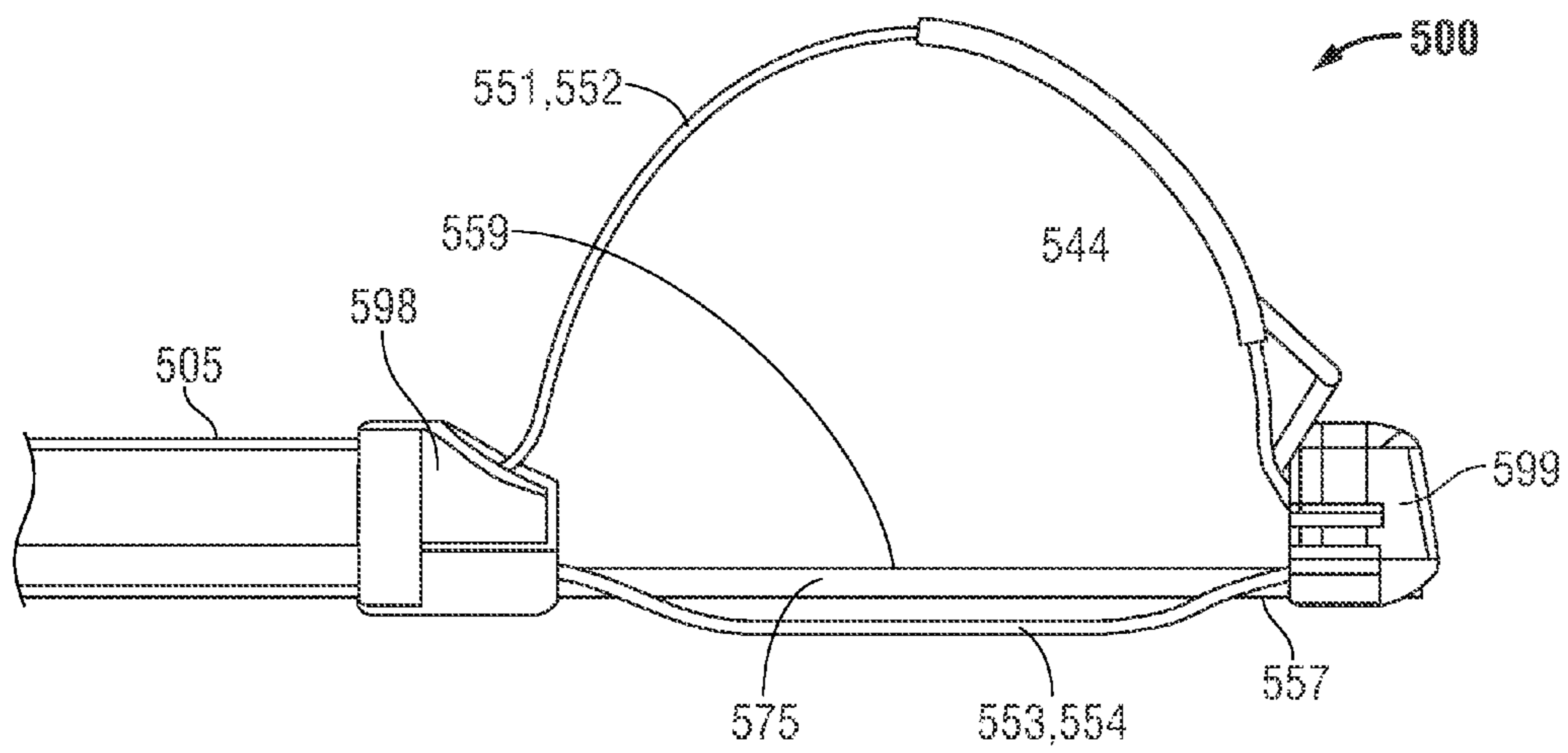

FIG. 5B

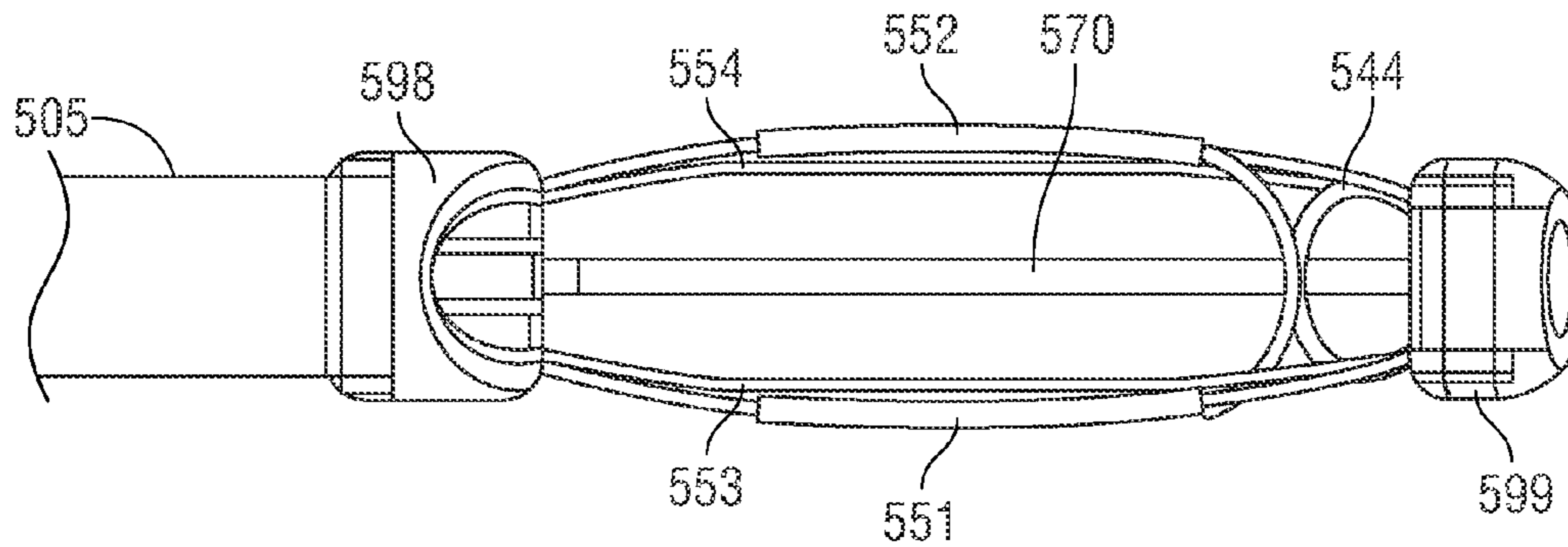

FIG. 5C

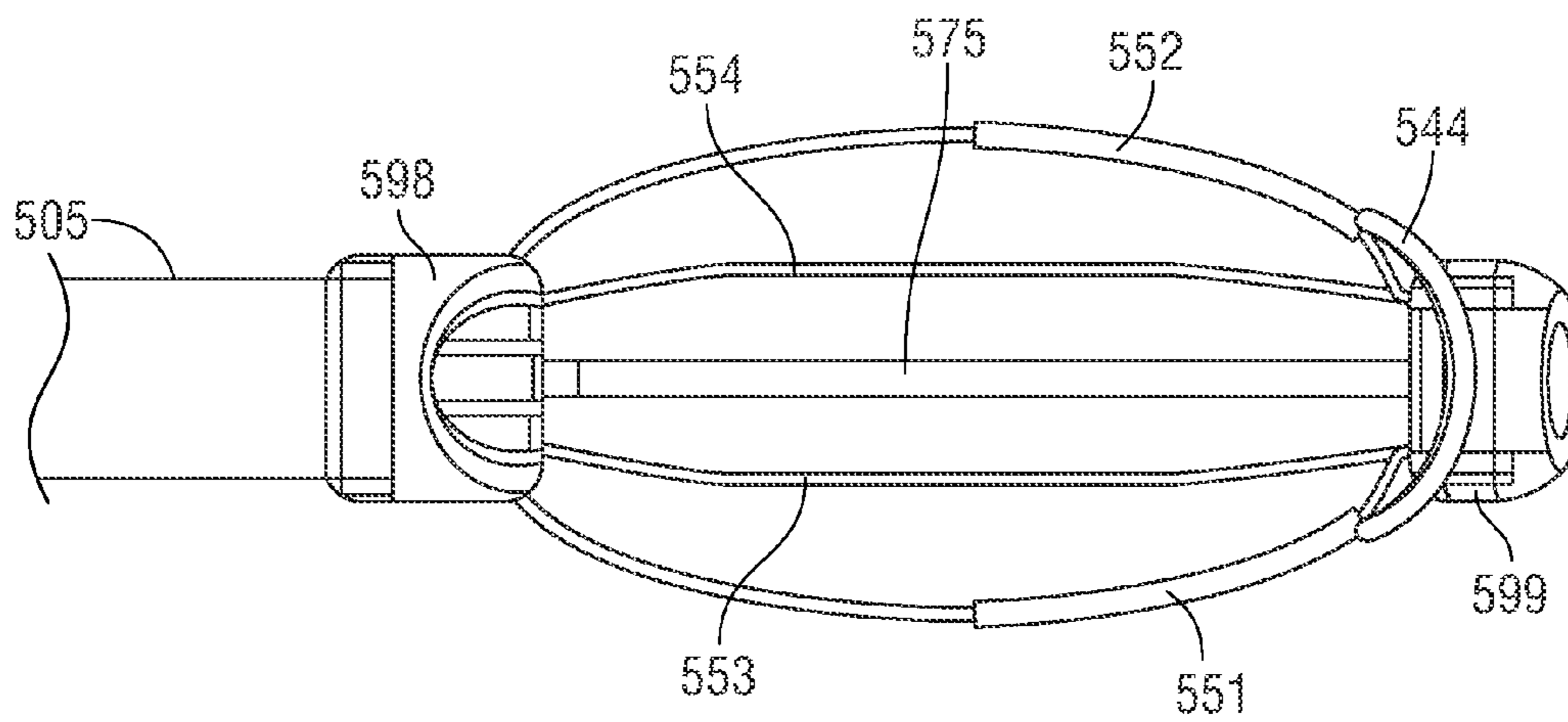

FIG. 5D



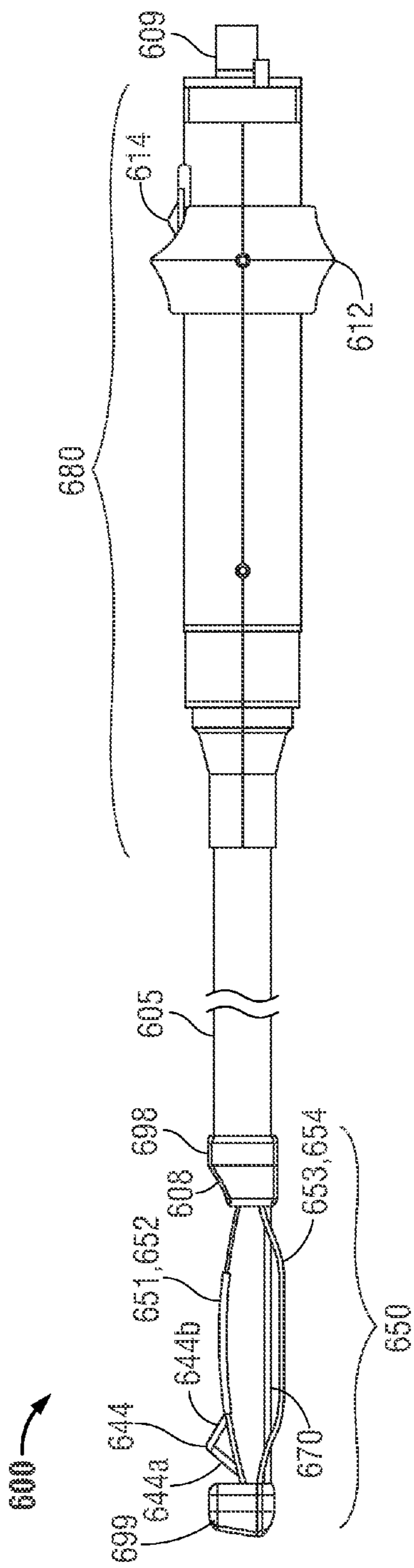

FIG. 6A

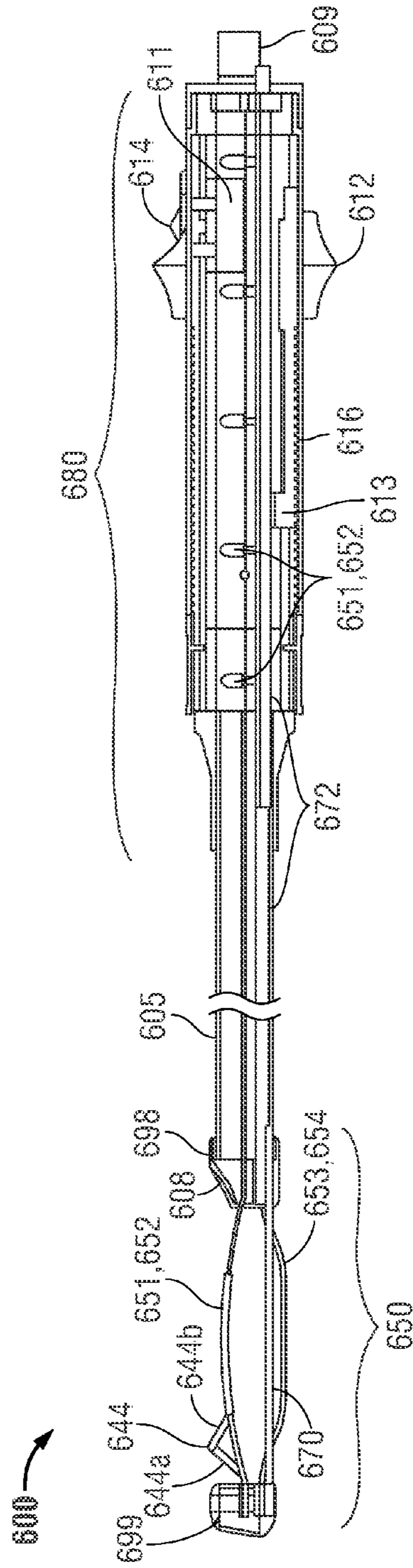

FIG. 6B

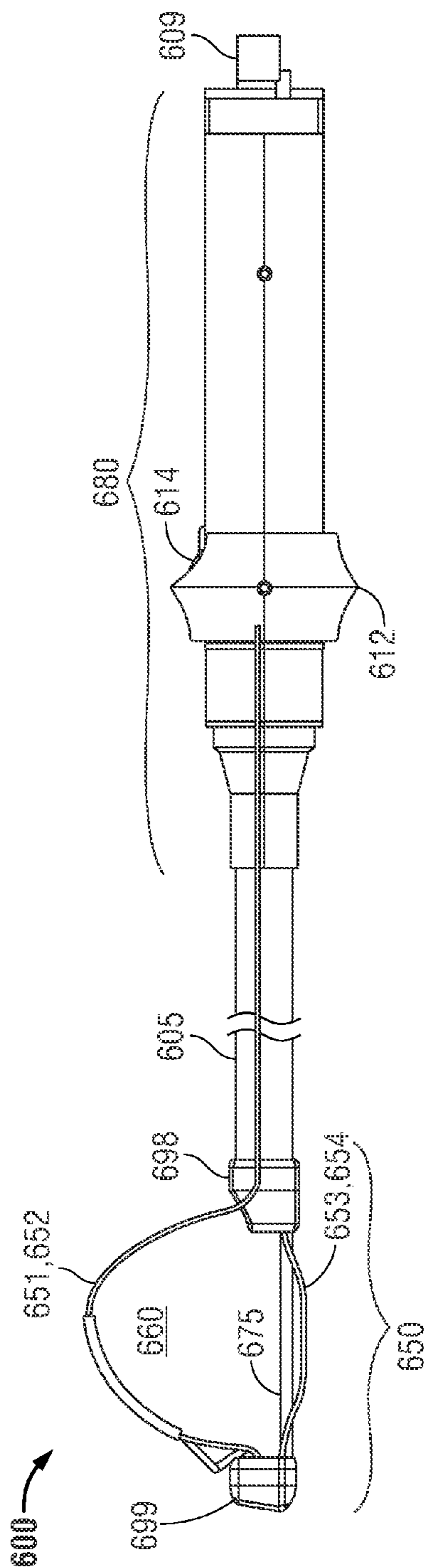

FIG. 60

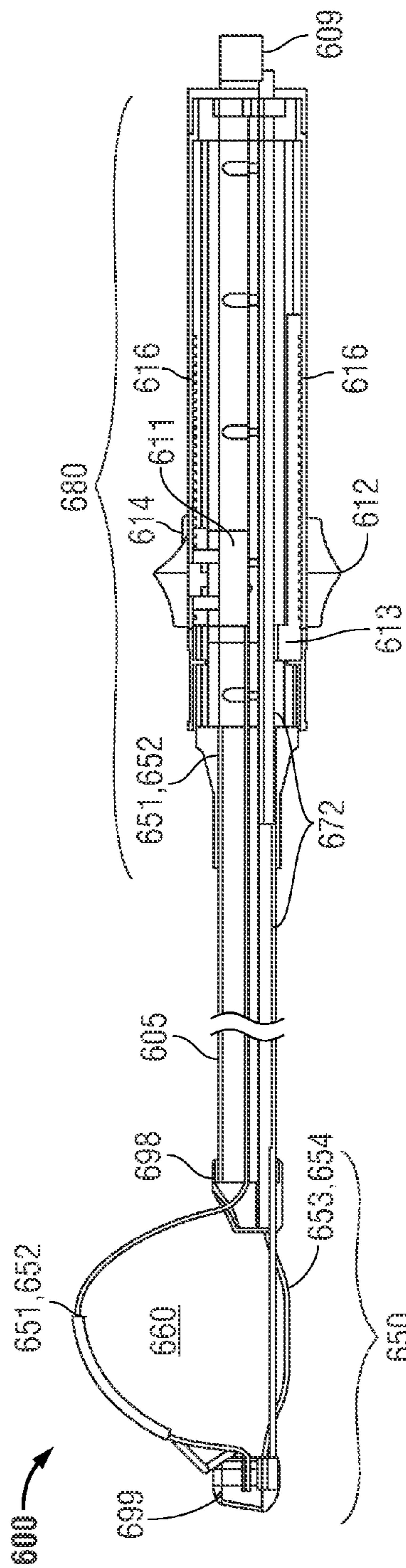

FIG. 6D

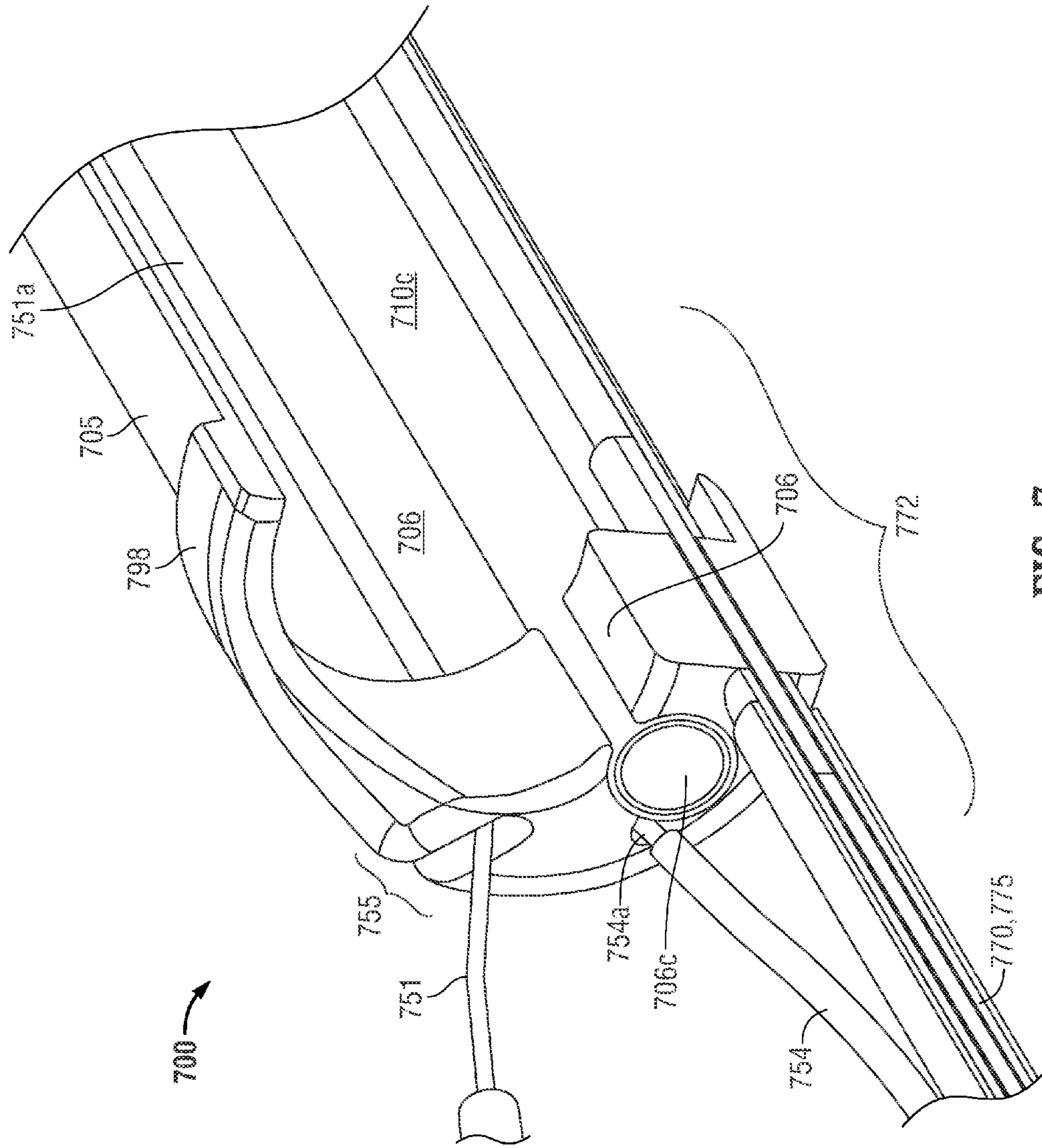

FIG. 7

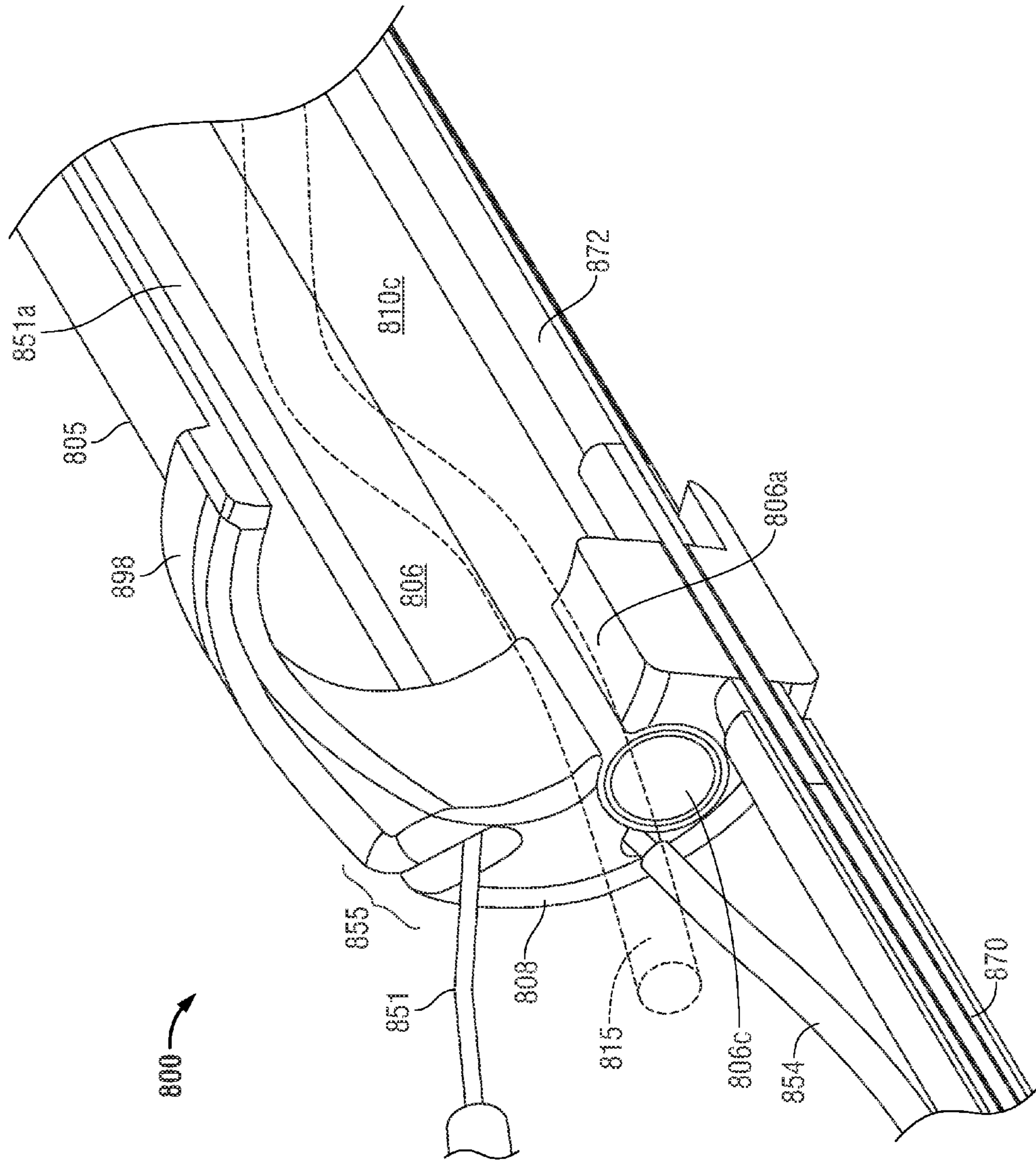

FIG. 8

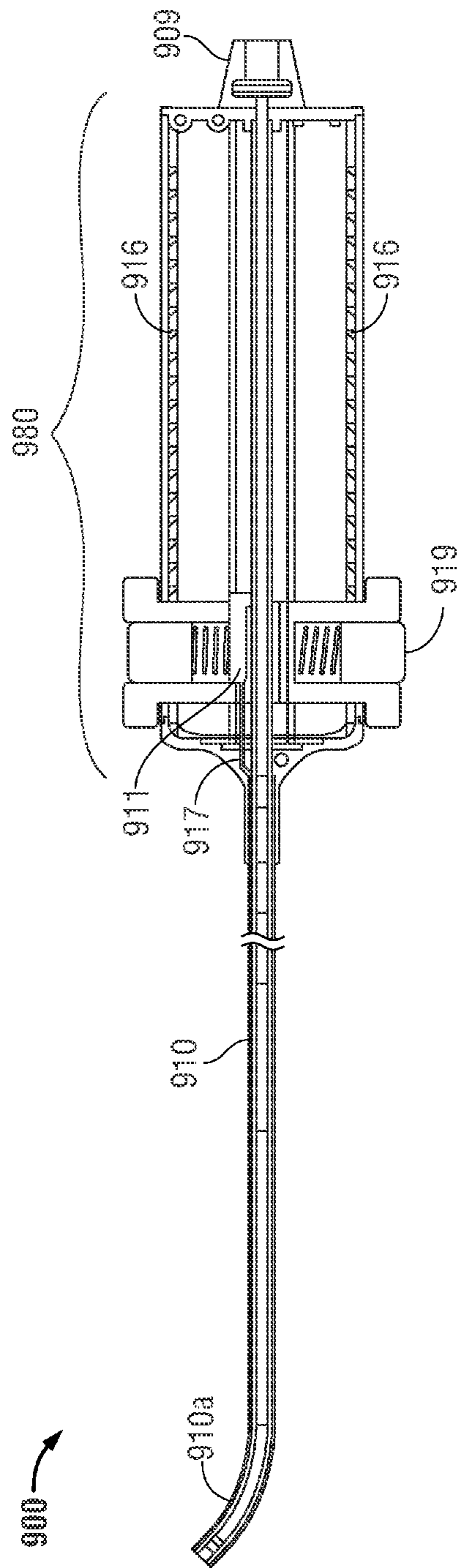

FIG. 9A

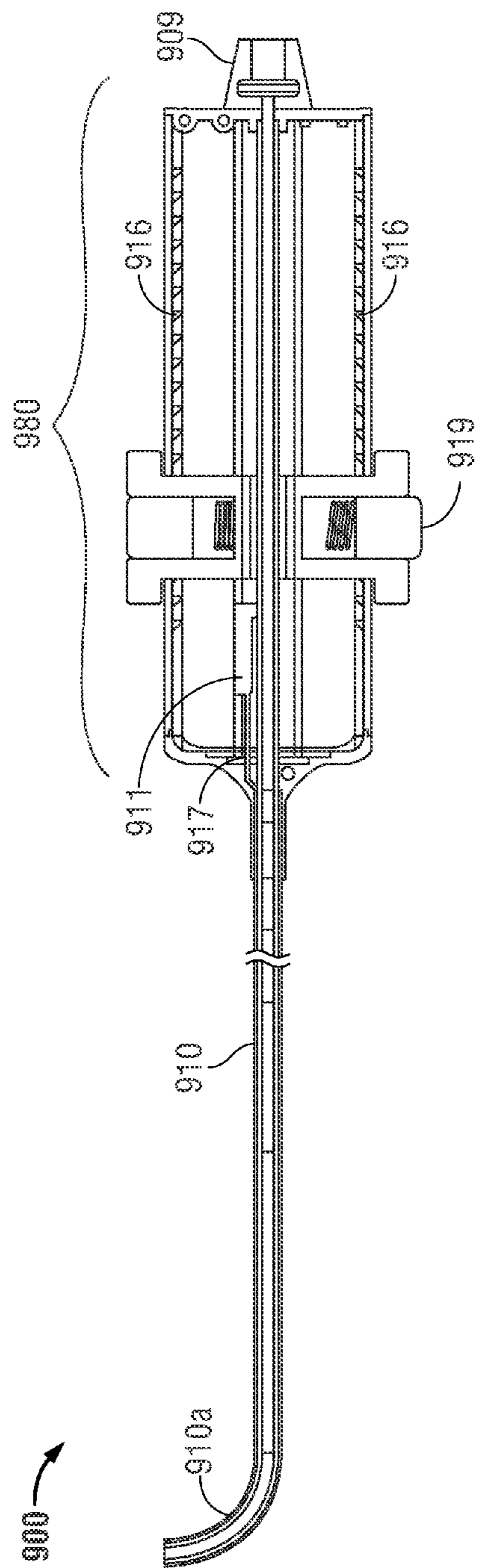

FIG. 9B

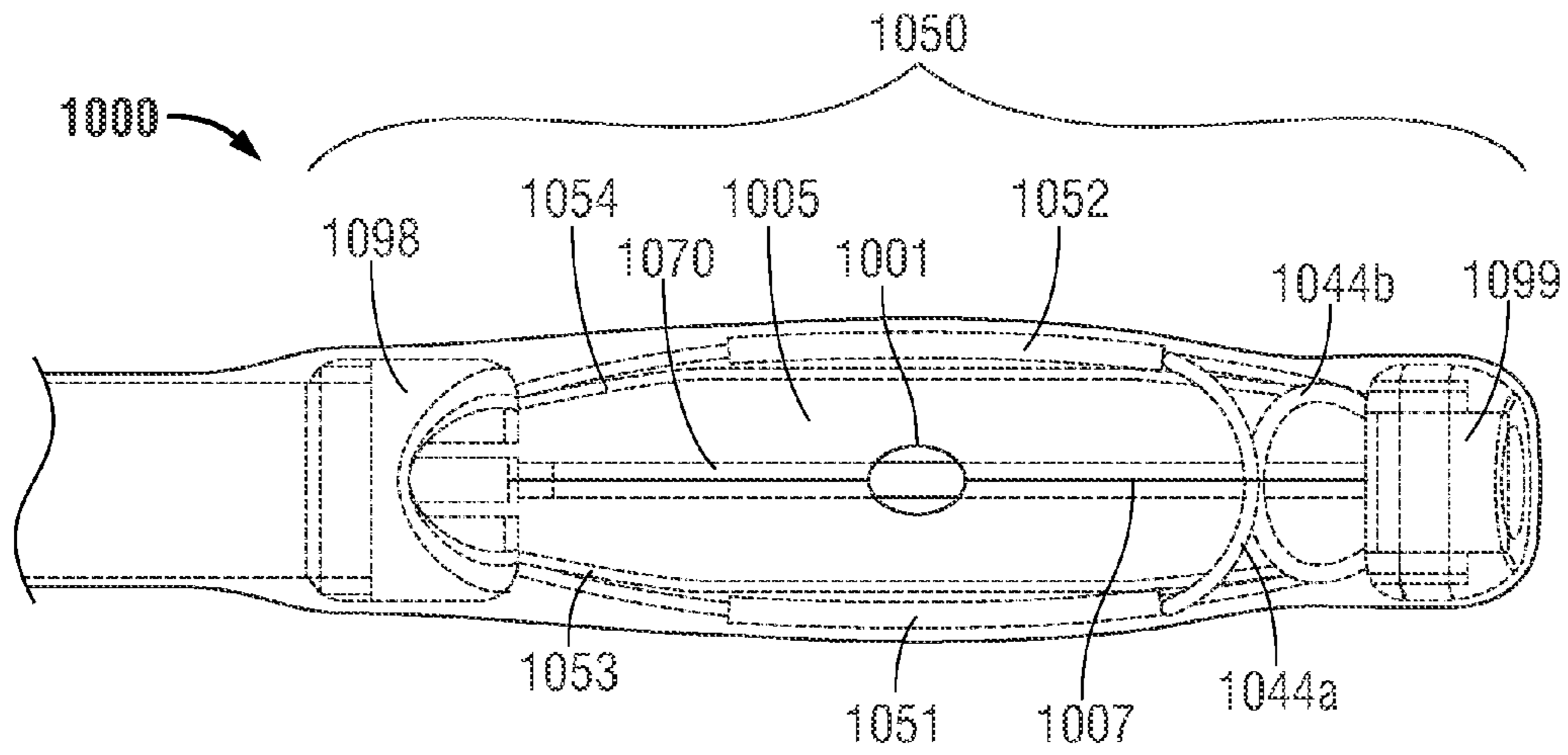

FIG. 10A

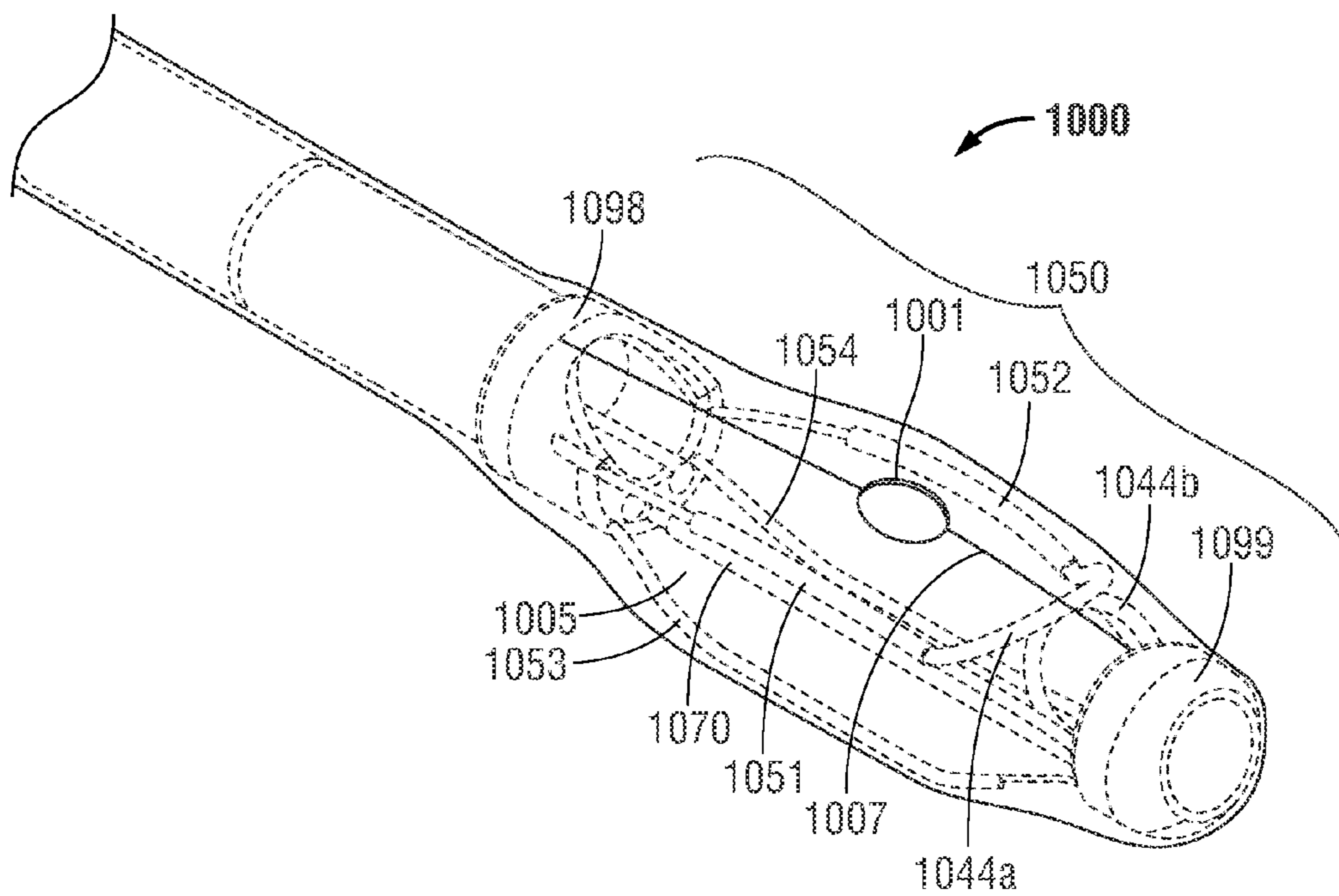

FIG. 10B

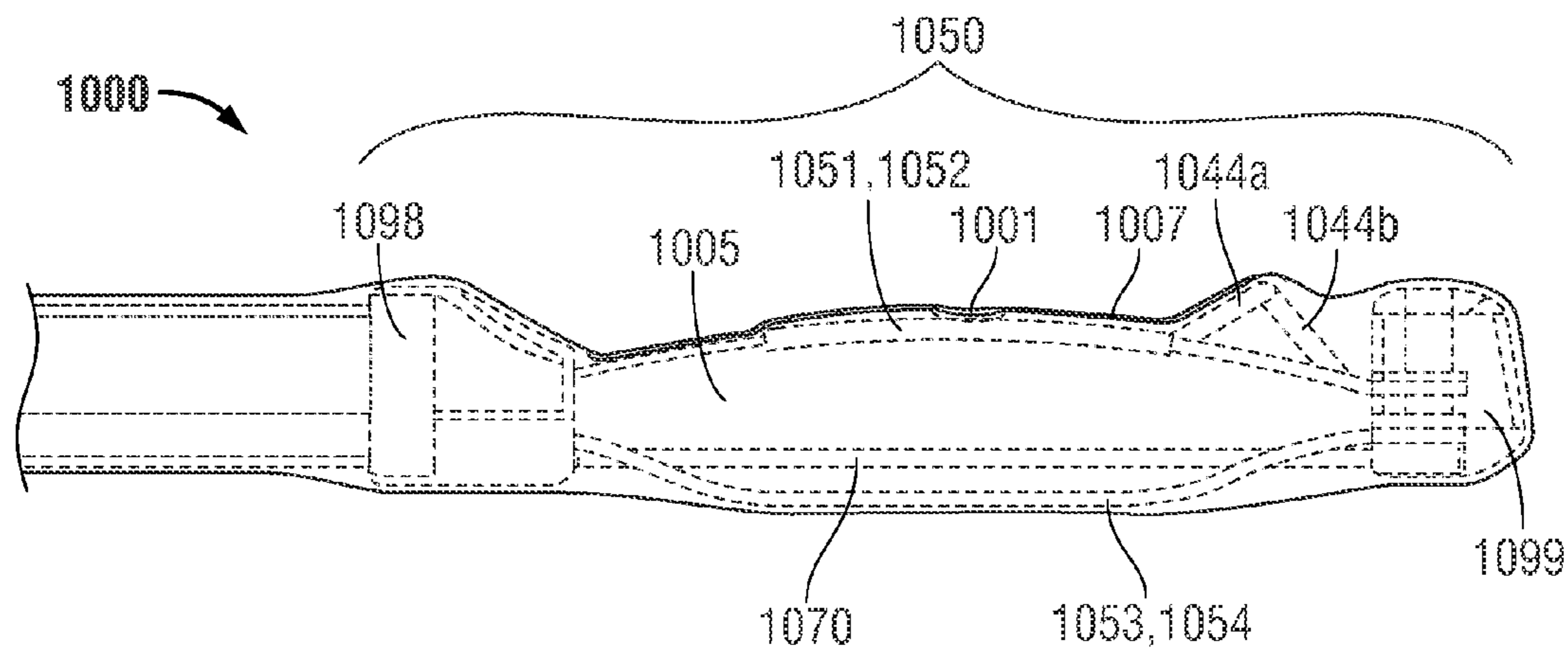

FIG. 10C

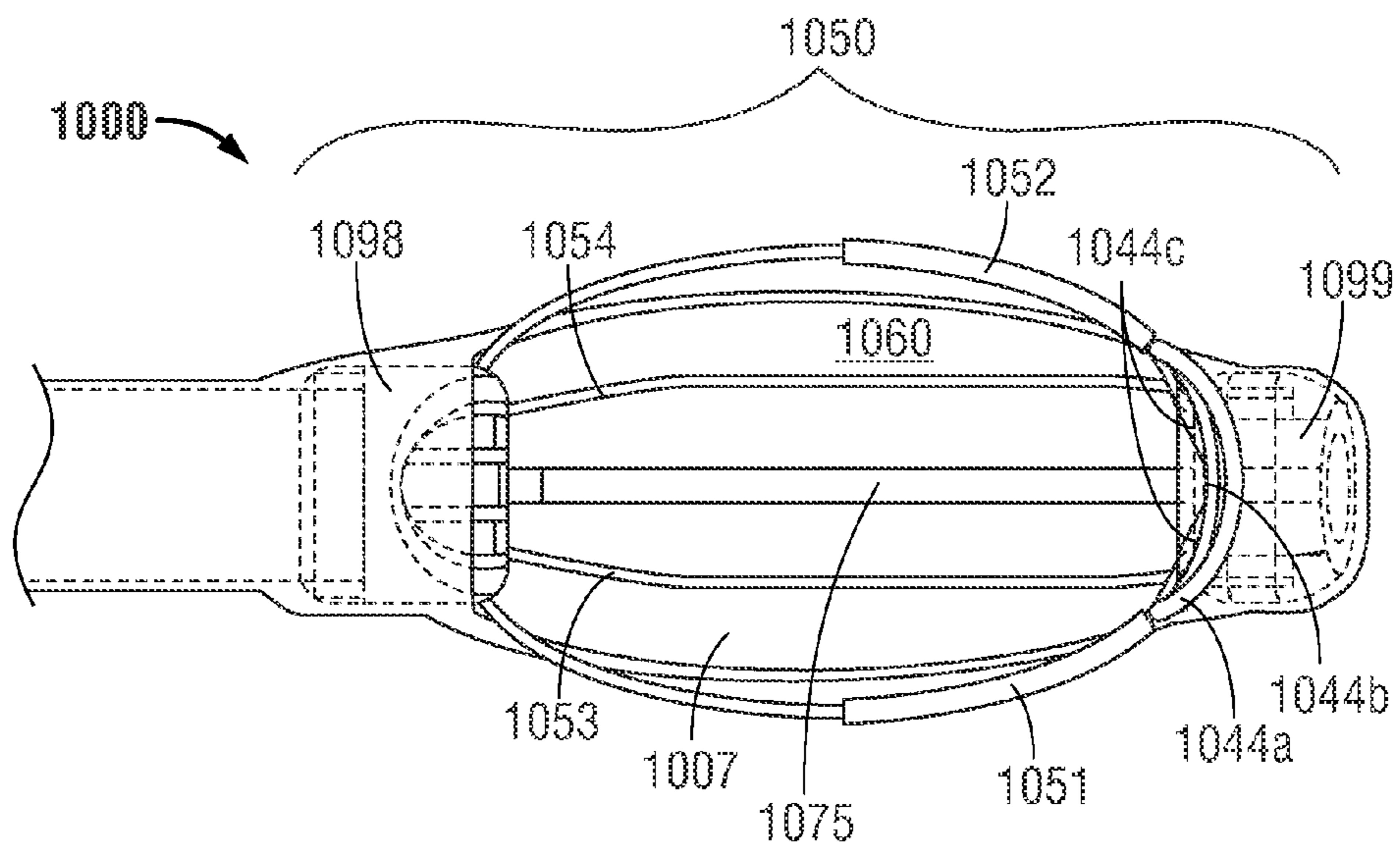

FIG. 10D

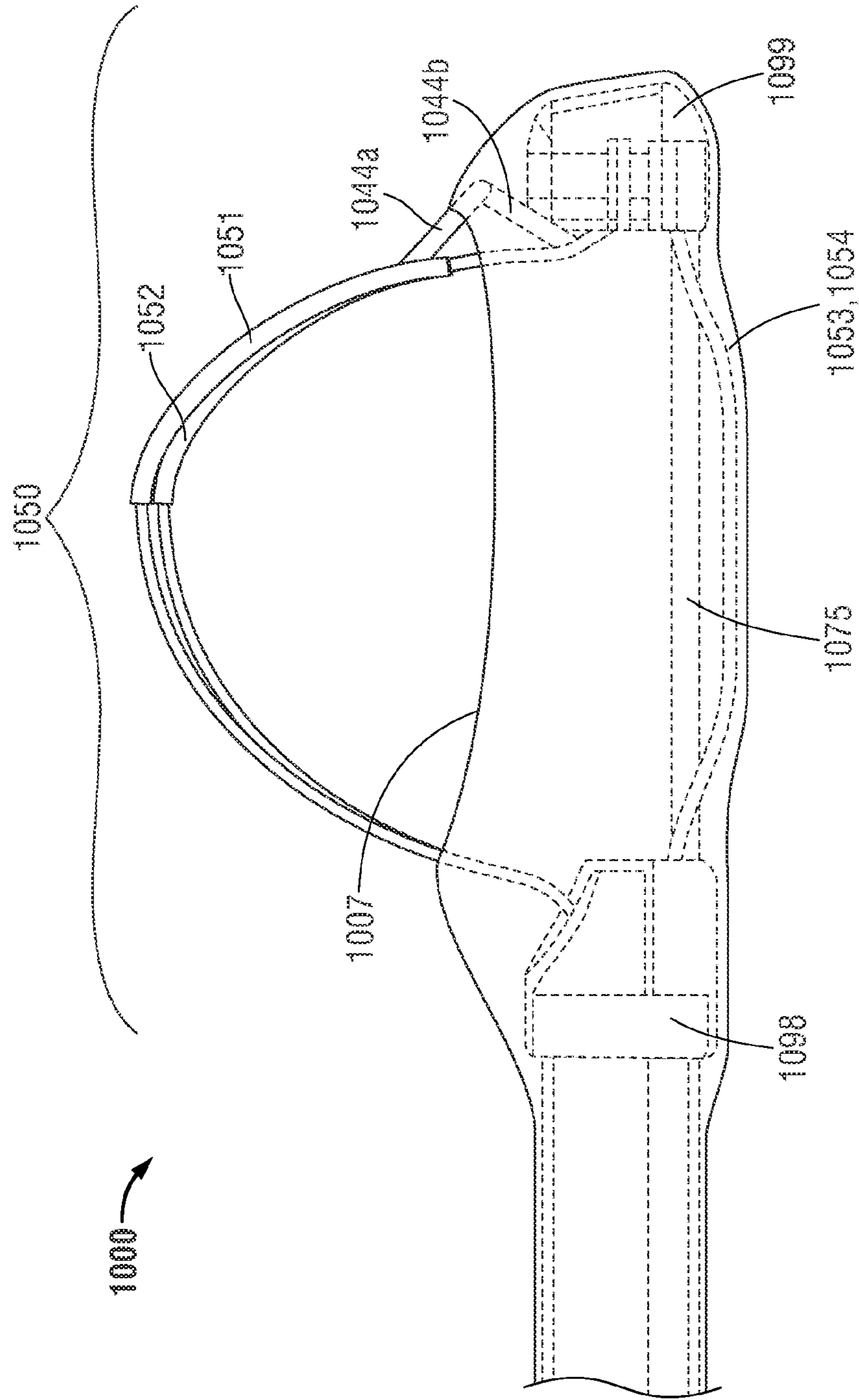

FIG. 10E



## ENDOLUMINAL SYSTEM FOR GASTROINTESTINAL TREATMENT

**Matter enclosed in heavy brackets [ ] appears in the original patent but forms no part of this reissue specification; matter printed in italics indicates the additions made by reissue; a claim printed with strikethrough indicates that the claim was canceled, disclaimed, or held invalid by a prior post-patent action or proceeding.**

This application is a continuation of application Ser. No. 13/862,346, filed Apr. 12, 2013, which is a continuation of application Ser. No. 13/531,477, filed Jun. 22, 2012, and is a continuation-in-part of application Ser. No. 12/970,604, filed Dec. 16, 2010, now U.S. Pat. No. 8,506,479, which claims priority from provisional application Ser. No. 61/287,077, filed Dec. 16, 2009. The entire contents of each of these applications are incorporated herein by reference.

### BACKGROUND

#### Field of the Invention

The teachings provided herein are generally directed to improved methods and devices for operatively treating gastrointestinal disorders endoscopically in a stable, yet dynamic operative environment, and in a minimally-invasive manner.

#### Description of the Related Art

Endoscopic procedures involving the gastrointestinal system offer advantages over conventional surgery in that they are less invasive and provide direct visualization. These procedures continue to evolve to address problems and provide new methods of treatment identified by those skilled in the art.

One current problem includes a lack of technology for an optimal minimally-invasive expansion of a stable, working space adjacent to the target tissues that could otherwise collapse around the target lesion or defect during an operative treatment. Having the ability to effectively expand and optimally reconfigure the working space could markedly facilitate an intra-luminal operation. A better expanded, stable and optimally configured working space allows the instruments and endoscope to be independently manipulated and properly visualized around the target tissue. One of skill would appreciate having the ability to see and approach both the target tissue and the surrounding anatomy for reference, orientation, and surgical maneuvering.

Another current problem includes a lack of an endoscopic technology for not only expanding, but also affixing and stretching, both the target tissue and surrounding tissue. In a bowel, for example, such a stable operative space could include a space that is non-collapsible, with limited peristalsis or aperistaltic, and/or affixed at a particular point in the abdominal cavity. The fixed point can be considered fixed in relation to, for example, a fixed body point in the patient, such as the patient's hip. Significant bowel movement is considered to be highly undesirable during an operation on the bowel, for example, since it may create a challenging, unstable operative environment. Such bowel movement is normal, of course, even in a sedated patient and can be caused, for example, by bowel collapse from an air leak, peristalsis, breathing, and movement of the scope and instruments. Having a technology to overcome this problem

would help provide a stable operative space, which is clinically desired by one of skill in the operative environment.

Another current problem includes a lack of an endoscopic technology for retracting the tissue dynamically, for example, through an adjustable tissue retraction structure allowing for a controlled degree of expansion or collapse of the structure, to further configure the working space as desired between the instruments and target tissue. Such control can effectively provide for a method of adjusting the retractor, as well as tissue placement, in-and-around the working space. By increasing and releasing the tension on the retractor, the amount of tissue to be placed in the working space, for example, can be better-gauged and controlled during a procedure. Moreover, the tissue retraction and, particularly, traction-contraction can be facilitated to help create a desired dissecting plane or position the tissue more optimally during an operation. Having a technology to overcome this problem would help create an operative environment that is more desirable for tissue dissection, retraction, cutting and a removal of tissue.

Another current problem includes a lack of an endoscopic technology for organizing the endoscope, instruments, and working space in a manner that can maximize the working space for the treatment. The larger space can improve the ability to manipulate the instruments and endoscope in a minimally-invasive manner from outside the body. Namely, one of skill would like to have a working space that has a point of entry for the instruments that is as far as practical from the target tissue to provide additional flexibility in approaching and visualizing the target tissue, perhaps providing more operating room for selecting a trajectory of the instruments toward the target tissue that is, for example, at least substantially perpendicular to the plane of dissection of the target tissue. Having a technology to overcome this problem would provide the person of skill with a system and procedure that is more desirable for a removal of tissue.

In view of at least the above, one of skill in the art of endoscopic, gastrointestinal surgical treatments would appreciate the technology taught herein which provides (i) a minimally-invasive expansion of target tissues; (ii) an affixing, particularly an affixing that includes a reconfiguring without stretching or reconfiguring with stretching, of both the target tissue and surrounding tissue to help provide a stable, operative space; (iii) a retracting of the tissue dynamically, allowing for a partial or complete expansion or collapse, to further configure the working space between the instruments and the target tissue; and (iv) an organization of the endoscope instruments, such as the retractor and tools to maximize the working space and maneuverability, allowing for a maximum flexibility in approaching and visualizing the target tissue. It should be appreciated that having such improvements would reduce the technical complexity, and increase the efficacy and safety of, otherwise complex endoscopic operations. Moreover, doing so at a low cost, while using an affordable system that is introduced in the subject atraumatically and in a manner that does not substantially disrupt the conventional colonoscopy workflow, would be seen by those of skill as a very substantial advancement in the field endoscopic surgical procedures.

### SUMMARY

The teachings provided herein are generally directed to improved methods and devices for operatively treating gastrointestinal disorders endoscopically in a stable, yet dynamic operative environment, and in a minimally-inva-

sive manner. The systems, for example, include an endoscopic surgical suite. The surgical suite can have a reversibly-expandable retractor that expands to provide a stable, operative environment within a subject. The expansion can be asymmetric around a stabilizer subsystem to maximize space for a tool and an endoscope to each be maneuvered independently to visualize a target tissue and treat the target tissue from outside the patient in a minimally invasive manner. Embodiments taught herein provide, among other improvements, an increase in distance between tool ports and the target tissue to improve maneuverability and triangulation of the tools with respect to the target tissue, as well as a larger field of view.

The teachings include a floating, multi-lumen-catheter retractor system for ease of positioning in a subject. These systems are designed to provide a minimally invasive treatment of the subject. In some embodiments, the systems comprise a highly flexible outer tube configured for guiding a floating channel and a floating endoscope in an at least substantially floating arrangement within the system. This flexible outer tube can have a lumen, a proximal end, and a distal end. And, during a use of the system, the floating channel can serve as a guide through which a tool is manipulated in a treatment of a target tissue in a subject. In some embodiments, the tool can include a grasper, a forcep, a snare, a clamp, a scissor, a knife, a dissector, an endoscopic stapler, a tissue loop, a clip applier, a suture-delivering instrument, or an energy-based tissue coagulator or cutter. And, in some embodiments, the floating channel can have an elevator component for moving a bendable section to manipulate the tool.

The system can also comprise a stable, yet dynamic operative environment in that it can include a reversibly-expandable retractor that expands to form a treatment space in the subject. The retractor can be configured, for example, for the expansion to occur distal to the distal end of the outer tube and at least substantially render the target tissue aperistaltic for the treatment. During the use of the system, the floating channel can be at least substantially attached to the lumen of the outer tube at a first proximal location and a first distal location, and be at least substantially floating in the lumen of the outer tube between the first proximal location and the first distal location. Likewise, during the use of the system, the floating endoscope can be at least slidably-attached to the lumen of the outer tube at a second proximal location and a second distal location, and be at least substantially floating in the lumen of the outer tube between the second proximal location and second distal location. And, during the use of the system, the at least substantially floating arrangement can at least substantially increase the flexibility of the system over a second such system, the second such system having a lumen for a tool and an endoscope affixed to the lumen throughout the length of the outer tube between the proximal end and the distal end of the outer tube. The increased flexibility of the at least substantially floating arrangement can facilitate an ease of positioning the system in the subject for the treatment of the target tissue.

In some embodiments, the retractor can be a reversibly-stabilized and reversibly-expandable retractor, retractor forming an asymmetrical treatment space upon the expansion. And, the retractor can be configured to reversibly stiffen an otherwise flexible arrangement of the retractor, the flexible arrangement designed to facilitate the ease of positioning of the system in the subject and to reversibly stiffen for the expansion of the retractor.

The teachings also include a multi-lumen catheter system having a reversibly-stabilized and reversibly-expandable retractor for a minimally invasive treatment of a subject. The system can comprise a flexible outer tube for guiding a channel and an endoscope within the system, the flexible outer tube having a lumen, a proximal end, and a distal end. The channel serves as a guide through which a tool is manipulated in a treatment of a target tissue in a subject. In some embodiments, the retractor can be a reversibly-stabilized and reversibly-expandable retractor forming a treatment space upon expansion and configured for the expansion to occur distal to the distal end of the outer tube. The retractor can be designed to reversibly-stiffen an otherwise flexible arrangement of the retractor, the flexible arrangement designed to facilitate the positioning of the system in the subject and to reversibly stiffen for the expansion of the retractor. In these embodiments, the reversibly-stiffened arrangement of the retractor can form an at least substantially rigid beam as a structural support for the expansion.

During a use of the system, the channel can be a floating channel that is (i) at least substantially attached to the lumen of the outer tube at a first proximal location and a first distal location and (ii) at least substantially floating in the lumen of the outer tube between the first proximal location and the first distal location. Likewise, during the use of the system, the endoscope can be a floating endoscope that is (iii) at least slidably-attached to the lumen of the outer tube at a second proximal location and a second distal location and (iv) at least substantially floating in the lumen of the outer tube between the second proximal location and second distal location. And, during the use of the system, the channel and the endoscope form an at least substantially floating arrangement that (v) at least substantially increases the flexibility of the system over a second such system having separate lumens for a tool and an endoscope, the separate lumens affixed to the lumen throughout the length of the outer tube between the proximal end and the distal end of the outer tube, the increased flexibility facilitating an ease of positioning the system in the subject for the treatment of the target tissue.

The teachings also include a surgical suite with a floating, multi-lumen-catheter retractor system having a reversibly-stabilized and reversibly-expandable retractor for a minimally invasive treatment of a subject. In these embodiments, the system can comprise a highly flexible outer tube for guiding a floating channel and a floating endoscope in an at least substantially floating arrangement within the system. The flexible outer tube can have a lumen, a proximal end, and a distal end; and, the floating channel can serve as a guide through which a tool is manipulated in a treatment of a target tissue in a subject. The retractor can be a reversibly-stabilized and reversibly-expandable retractor forming a treatment space upon expansion. The retractor can be configured, for example, for the expansion to occur distal to the distal end of the outer tube and to reversibly stiffen an otherwise flexible arrangement of the retractor, the flexible arrangement designed to facilitate the positioning of the system in the subject and to reversibly stiffen for the expansion of the retractor.

During a use of the system, the floating channel can be (i) at least slidably-attached to the lumen of the outer tube at a first proximal location and a first distal location and (ii) at least substantially floating in the lumen of the outer tube between the first proximal location and the first distal location. Likewise, during the use of the system, the floating endoscope can be (iii) at least slidably-attached to the lumen of the outer tube at a second proximal location and a second

distal location; and, (iv) at least substantially floating in the lumen of the outer tube between the second proximal location and second distal location. And, during the use of the system, the at least substantially floating arrangement can (v) at least substantially increase the flexibility of the system over a second such system having lumens for a tool and an endoscope, the lumens affixed to the lumen of the outer tube throughout the length between the proximal end and the distal end of the outer tube. The increased flexibility can facilitate an ease of positioning of the system in the subject; and, the reversibly-stiffened arrangement of the retractor can form an at least substantially rigid beam as a structural support for the expansion in the subject for the treatment of the target tissue.

In some embodiments, the retractor comprises at least two expandable retractor elements, each of the members having a proximal end and a distal end, the proximal end slidably engaged with the outer tube, and each of the members configured such that an increase in the amount of sliding of the proximal end toward the distal end compresses the member and expands the retractor. These embodiments can also include a distal nexus located distal to the distal end of the outer tube and at which the distal end of each of the at least two retractor elements is affixed; and, a stabilizer subsystem connecting the distal nexus to the distal end of the outer tube and having an at least substantially rigid component configured to reversibly stiffen an otherwise flexible portion of the retractor for an asymmetric expansion of the retractor.

In some embodiments, the retractor comprises four expandable retractor elements, each of the members having a proximal end and a distal end, the proximal end slidably engaged with the outer tube, and each of the members configured such that an increase in the amount of sliding of the proximal end toward the distal end compresses the member and expands the retractor. These embodiments can also include a proximal coupler attached to the distal end of the outer tube, the proximal coupler having four retractor ports for the slidable engagement with the four retractor elements, the four retractor ports positioned circumferentially around the proximal coupler and configured to facilitate a reversible, axial sliding of the retractor elements for the asymmetric expansion of the retractor. These embodiments can also include a distal nexus located distal to the distal end of the outer tube and at which the distal ends of each of the four retractor elements are affixed; and, a stabilizer subsystem connecting the distal nexus to the distal end of the outer tube and having (i) a flexible component that extends from the proximal coupler to the distal nexus and (ii) an at least substantially rigid component that is slidably engaged with the proximal coupler and reversibly extends from the proximal coupler to the distal nexus to reversibly-stiffen the retractor in an asymmetric expansion of the retractor.

The flexible component and the rigid component can have central axes that are each at least substantially parallel to the central axis of the distal end of the shaft, the rigid component forming an at least substantially rigid beam as a structural support for the asymmetric expansion, the rigid beam having a luminal side and an abluminal side. And, the expansion can occur in a disproportionally greater amount on the luminal side of the rigid beam to increase the treatment space, the treatment space having a volume that is asymmetrically distributed around the rigid beam. In some embodiments, the expansion can occur in an amount that is at least 5× greater on the luminal side of the beam than the abluminal side of the beam.

In some embodiments, the system can include a bridge member configured to maintain a desired orientation of the retractor elements during the expansion, the bridge member operably stabilizing at least two of the four retractor elements. Moreover, in some embodiments, the outer tube can be wire-reinforced to provide kink resistance and torqueability to the system to further facilitate a positioning of the system in the subject.

The systems provided herein can be used in several different methods of treatment. For example, the systems can be used in a method of treating a gastrointestinal lesion using a multidirectional and multi-angular approach to the lesion. The method can include positioning the system in a subject's gastrointestinal tract, the positioning including placing the retractor in proximity to a target lesion for a treatment; expanding the retractor to create the treatment space for use of the tool; improving visualization, for example, some lesions can be seen much better when tissue is retracted and stabilized; optimally positioning the target tissue in relation to the tool, for example, by optimizing the position of the duodenal papilla, facilitating its cannulation during a procedure; treating the target tissue with the tool; collapsing the retractor; and, withdrawing the system from the subject. The lesion can include, for example, a perforation, a tissue pathology a polyp, a tumor, a bleed, a diverticuli, an ulcer, a cancerous tissue, an abnormal vessel, or an appendix.

#### BRIEF DESCRIPTION OF THE FIGURES

FIG. 1 illustrates a system for operatively treating gastrointestinal disorders endoscopically in a stable, yet dynamic operative environment, and in a minimally-invasive manner, according to some embodiments.

FIGS. 2A and 2B illustrate how a system as taught herein can be positioned for treating a lesion in the ascending colon, according to some embodiments.

FIGS. 3A-3L illustrate how a system as taught herein can be used in removing a lesion in a colon, according to some embodiments.

FIGS. 4A-4E illustrate details of a system as taught herein, in side, axial, and oblique views of expanded and collapsed configurations, and including a stabilizer subsystem, according to some embodiments.

FIGS. 5A-5D illustrate side and top views of a system as taught herein, having side views and top views of expanded and collapsed configurations, according to some embodiments.

FIGS. 6A-6D illustrate side views of a system as taught herein, having side views and cross-sections of expanded and collapsed configurations of the system, according to some embodiments.

FIG. 7 illustrates a cutaway view of the distal end of the outer tube of a system as taught herein, showing components of the expansion and collapse of the retractor, according to some embodiments.

FIG. 8 illustrates the cutaway view of FIG. 7, showing the distal end of the outer tube of a system as taught herein, in which components of the system can be floating in the outer tube to enhance flexibility for positioning the system in a subject, according to some embodiments.

FIGS. 9A and 9B illustrate side views of working, and/or floating, channels that can be used to guide tools as taught herein, according to some embodiments.

FIGS. 10A-10E illustrate a retractor sheath covering a retractor of a system as taught herein, according to some embodiments.

#### DETAILED DESCRIPTION

The teachings provided herein are generally directed to improved methods and devices for operatively treating gastrointestinal disorders endoscopically in a stable, yet dynamic operative environment, and in a minimally-invasive manner. The systems, for example, include an endoscopic surgical suite. The surgical suite can have a reversibly-expandable retractor that expands to provide a stable, operative environment within a subject. In some embodiments, the expansion can be asymmetric around a stabilizer subsystem to maximize space for a tool and an endoscope to each be maneuvered independently to visualize a target tissue and treat the target tissue from outside the patient in a minimally invasive manner. Embodiments taught herein can provide, among other improvements, an increase in distance between tool ports and the target tissue to enhance the independent maneuverability and triangulation of each of the tools with respect to the target tissue. This increase in distance can also provide a way of obtaining a larger field of view. The systems taught herein, for example, can (i) enable a working space to be dynamically configured around the target tissue in tortuous body lumens and orifices such as the gastrointestinal tract using controls from outside the body; (ii) provide a flexible, passageway for multiple surgical tools and instruments, such as endoscope and graspers to be passed from outside the body towards the target tissues; (iii) organize and/or constrain tools in the working space; (iv) at least substantially immobilize and/or stabilize the target tissue and surrounding tissue for a treatment; and/or (v) enable control over the geometry position, and orientation of the instruments such as the grasper in the working space from outside the body.

The terms "treat," "treatment", and "treating" include, for example, the therapeutic and/or prophylactic uses in the prevention of a disease or disorder, inhibition of a disease or disorder, and/or amelioration of symptoms of disease or disorder. The term "subject" and "patient" can be used interchangeably and refer to an animal such as a mammal including, but not limited to, non-primates such as, for example, a cow, pig, horse, cat, dog, rat, and mouse; and, primates such as, for example, a monkey or a human.

In some embodiments, the systems taught herein can include dynamically reconfigurable, asymmetric retractor structures on the distal end of a flexible and torque-able multi-channel shaft having a handle that allows for control over both the stiffness and geometry of the working space formed by the expansion of the retractor. In some embodiments, the retractor can include a stabilizer subsystem having 2-8, 3-5, 4-6, or any range therein, flexible retractor elements. In some embodiments, the retractor elements can be aligned at least substantially parallel to each other when fully collapsed for positioning in the patient. In some embodiments, the retractor elements are aligned on planes that are within about 5-30 degrees, about 10-25 degrees, about 15-20 degrees, about 15 degrees, or any range therein, of each other, in some embodiments. In some embodiments, the retractor elements form a frame that has a length ranging from about 4-12 cm, 6-10 cm, 7-9 cm, 5-11 cm, or any range therein. In some embodiments, the frame is about 8 cm long. In some embodiments, the retractor elements form a frame that has a width ranging from about 1-5 cm, 2-4 cm, or any range therein. In some embodiments, the frame is about 3

wide. In some embodiments, the retractor elements form a frame that has a height ranging from about 1-5 cm, 2-4 cm, or any range therein. In some embodiments, the frame is about 3 cm high. One of skill will appreciate that there are a number of suitable materials that can be used to make the retractor elements for the purposes set-forth herein. In some embodiments, the retractor elements can be made from NITINOL. In some embodiments, the retractor element can comprise, multifilament steel wires or polymer cords. The polymer materials can include polyetheretherketone (PEEK), nylon, polyester, polycarbonate, polyurethane, or polyethylene. The gauge of the retractor elements can vary, depending on material. In some embodiments, the retractor elements can comprise wires that range from about 0.020"-0.40" in diameter. In some embodiments, the retractor elements are 0.030" in diameter.

The term "about" is used in the teachings herein to describe possible variations in amounts or ranges that can be used in embodiments. It can be used in embodiments, for example, to include the exact amount or range specified, as well as a variation of which that would not create a substantial difference in function. A difference in function can be insubstantial, for example, where it is less than 20% in some embodiments, less than 15% in other embodiments, less than 10% in yet other embodiments, or perhaps even less than 5% in yet other embodiments. One of skill will appreciate that the percentage difference in function required for to be substantial will depend on the function of the embodiment itself that is under comparison.

The methods, devices, and systems taught herein can be used for minimally-invasive procedures. A non-invasive procedure, in contrast, can be defined as a procedure that includes no violation of the skin or the mucosa, and no appreciable damage to any other tissues of the body. A minimally-invasive surgical operation, on the other hand, involves minimal access trauma and minimal collateral tissue damage during a surgical operation. The terms "minimal," "minimize," "minimizing," "minimized," "avoid," "avoiding," "avoided," can be used interchangeably in some embodiments. Minimally-invasive surgery is desirable, for example, to reduce trauma to the patient, speed the healing process, reduce risk and, thus, reduce the length and expense of a hospital stay by minimizing or avoiding tissue damage, or risk of tissue damage. Tissue damage, or the risk thereof, can be minimized or avoided, for example, where a procedure is designed to minimize or avoid unnecessary tissue contact that may otherwise be associated with a procedure. The gentle procedures taught herein, for example, are directed to preserving tissue during a gastrointestinal surgery.

The systems taught herein can be dynamic in some embodiments, for example, such that the tissue retraction can include partial or complete expansion or collapse of a retractor to facilitate an increase or decrease in the distance between instruments and the target tissue, which is useful in reconfiguring the work space and aiding in axial movements of the tools. By increasing and releasing the tension, the amount of tissue to be placed in the working space can also be better-gauged during a procedure, for example, and tissue traction-contraction can be facilitated to help in creating a dissecting plane during a removal of tissue. One of skill will appreciate having the ability to dynamically reconfigure the working space and optimize traction-contraction on the target tissue, as this can facilitate surgical manipulations.

FIG. 1 illustrates a system for operatively treating gastrointestinal disorders endoscopically in a stable, yet dynamic operative environment, and in a minimally-inva-

sive manner, according to some embodiments. The system **100** can include a multi-lumen-catheter retractor system for ease of positioning in a subject, and such systems can be designed to provide a minimally invasive treatment of the subject. The system **100** can have a flexible outer tube **105** configured for guiding a channel **110** and an endoscope **115** within the system **100**. The flexible outer tube **105** can have a lumen (not shown), a proximal end (not shown), and a distal end (not shown) to house, for example, the channel and the endoscope during use of the system **100**. As such, the outer tube can be a multi-luminal tube, in some embodiments. And, during the use of the system **100**, the channel **110** can serve as a guide through which a tool **120,125** can be manipulated in a treatment of a target tissue **190** in the gastrointestinal tract **195** of the subject. The channel **110** can, for example, be in operable contact with an independently manipulable-and-articulable tool, the channel having an elevator component for moving a bendable section.

In some embodiments, the tool can be any tool known to one of skill. For example, the tool **120,125** can include a grasper, a forcep, a snare, a scissor, a knife, a dissector, a clamp, an endoscopic stapler, a tissue loop, a clip applicator, a suture-delivering instrument, or an energy-based tissue coagulator or cutter. And, in some embodiments, the channel **110** can have an elevator component (not shown) for moving a bendable section, often a distal end of the channel **110**, to manipulate the tool **120,125**. In some embodiments, at least one channel **110** and/or the endoscope **115** can have at least substantial freedom to move within the outer tube **105** during operation, or "float," such that the system **100** can be considered to be a floating, multi-lumen-catheter retractor system. It should be appreciated that the terms "tool" and "instrument" can be used interchangeably in some embodiments taught herein.

In some embodiments, the system can comprise a stable, yet dynamic operative environment in that it can include a reversibly-expandable retractor **150** that expands to form a treatment space **160** in the subject. The retractor **150** can be configured, for example, for the expansion to occur distal to the distal end **108** of the outer tube **105**. In some embodiments, the retractor can at least substantially render the target tissue **190** aperistaltic for the treatment. The retractor **150** can have a variety of configurations to serve, for example, as a scaffolding within the gastrointestinal tract **195**. For example, the retractor **150** can include retractor elements **151,152,153,154**, along with a proximal coupler **198** operably connected to the retractor elements **151,152,153,154**, whether at least substantially attached and/or at least slidably-engaged to the retractor elements **151,152,153,154**, and a distal nexus **199** for a distal point of an operable connection with the retractor elements **151,152,153,154**.

Moreover, the retractor **150** can be a reversibly-stabilized and reversibly-expandable retractor, the retractor **150** forming an asymmetrical treatment space **160** upon the expansion. And, the retractor **150** can be configured to reversibly stiffen an otherwise flexible arrangement of the retractor **150**, the arrangement designed to facilitate ease of positioning of the system **100** in the subject and to reversibly stiffen for the expansion of the retractor **150**. The stabilization of the retractor **150** can, in some embodiments, include a means for stabilizing the retractor **150** through a stabilizer subsystem as taught herein, the stabilizer having, for example, an at least substantially-rigid beam **175** to support the expanded retractor **150**.

In some embodiments, the outer tube can have any dimensions believed to be useful to one of skill for the

purposes taught herein. For example, the outer tube can have an outer diameter ranging from about 3 mm to about 30 mm, about 5 mm to about 25 mm, about 7 mm to about 22 mm, from about 9 mm to about 20 mm, from about 11 mm to about 18 mm, from about 8 mm to about 15 mm, from about 10 mm to about 16 mm, or any range therein in increments of 1 mm. The length of the outer tube can range, for example, from about 30" to about 72", from about 31" to about 36", from about 28" to about 80", from about 32" to about 40", from about 34" to about 38", or any range therein in increments of 1".

The outer tube can be manufactured from any materials known to be useful to one of skill for the purposes taught herein. For example, the outer tube can comprise a polymer, or perhaps a polymer having an embedded wire reinforcement. The wire reinforcement can be a mesh, a braid, a helical coil or any combination thereof. The wire reinforcement can include any material believed by one of skill to be useful for the purposes set-forth herein. For example, wire reinforcement can comprise a material having an elastic modulus that is about 1-3 orders of magnitude higher than the polymer tube. The wire material can comprise, for example, a stainless steel having a diameter ranging from about 0.003" to about 0.017", about 0.005" to about 0.015", about 0.010" to about 0.012", or any range therein in increments of about 0.001". The tube hardness, or durometer, can be any of that which one of skill will find useful for the purposes set forth herein. For example, the hardness can range, for example, from about 50 Shore A to about 60 Shore A, about 40 Shore A to about 80 Shore A, about 45 Shore A to about 70 Shore A, or any range therein in increments of 1 Shore A. One of skill will appreciate that the outer tube should be flexible, elastically bendable, but sufficiently stiff torsionally to transmit torque from the handle or proximal end of the system to the retractor or distal end of the system.

The outer tube can be connected to a ring distally, referred to herein as the proximal coupler in some embodiments, which can have portals for retractor elements to slide through, as well as a desired orientation and positioning of the channels for the endoscope and at least one tool, such that the retractor elements, endoscope, and at least one tool are organized relative to each other in a predetermined manner to achieve a particular function, such as an increase in working space, a better view of a plane of dissection, or any other procedural variable deemed of interest to one of skill.

In some embodiments, the retractor structures taught herein are each a means for substantially immobilizing the lesion to the extent desired for the treatment. For example, the current use of loops and a piece-meal removal of flat or wide-based polyps, such as those having a base of about 1 cm or wider, may not provide clear surgical margins, whereas the systems taught herein can, in some embodiments, immobilize or affix the entire circumference of the bowel wall around the treatment area and facilitate the production of clear surgical margins. One of skill will appreciate having a working space that can be provided by the systems taught herein, the working space being (i) at least substantially non-collapsible, (ii) at least substantially aperistaltic; and, (iii) at least substantially affixed at a particular point in the abdominal cavity in relation to any fixed body point, like a hip, for example. This is a significant improvement over existing systems, as existing systems have not addressed many existing problems including, for example, bowel collapse that can result from an air leak from the working space; peristalsis that is normal, even in a sedated patient; and, additional undesired bowel movements

caused by the patient's breathing, movement of the scope or other instrument manipulation, or perhaps even by a surrounding peristalsis causing movement at a treatment area. Such problems are addressed by systems taught herein. As such, systems taught herein can offer a rigid, stable structure having at least substantial resistance to a variety of moving forces in the abdomen that are typically present during a gastrointestinal endoscopic procedure. One of skill will appreciate decreasing the effects of these moving forces on the working space to help reduce otherwise inherent technical complexities, limited efficacies, and decreased safety during endoscopic procedures.

In some embodiments, the systems taught herein can be slidably positioned over an endoscope during use. In fact, it should be appreciated that there are a variety of methods of using systems taught herein that are already used by one of skill in current state-of-the-art procedures. For example, the method can include inserting the multi-luminal tube into an overtube, cover, or sheath. And, in some embodiments, the endoscope can be a colonoscope. In many embodiments, regardless of the method of use, the retractor structures can mechanically retract one side of the colonic wall in an asymmetric manner to increase the distance between the target lesion and the opposite wall, as well as between the lesion and the instruments in their most retracted, but visualized, position to increase the effective work space.

In some embodiments, the systems can include a multi-lumen catheter having at least 2 working channels for manipulating tools and an endoscope, each of the two working channels having 6 degrees of freedom that are independent from each other and the endoscope. The ability to independently manipulate the endoscope and tools allows, for example, one instrument to retract the tissue or lesion away or substantially perpendicular to another instrument, for example, the dissecting instrument, while independently optimizing the endoscope's position and, hence, the view of the treatment area. This would facilitate the removal of tissue with clear margins. The channels can manipulate the tools with several degrees of freedom, 6 degrees of freedom in some embodiments, providing a greatly enhanced maneuverability in the working area when compared to current state-of-the-art systems. In some embodiments, the at least one independently manipulable-and-articulate tool can be independently rotatable to an angle of up to about 360 degrees, about 315 degrees, about 270, about 225 degrees, about 180 degrees, about 135 degrees, or about 90 degrees in the working area. In addition the tools can be independently bendable to an angle of up to about 180 degrees, about 135 degrees, about 90 degrees, or about 45 degrees in at least one direction in the working area.

The systems taught herein can have a means for organizing the orientation of the floating channels, in order to further facilitate improving the flexibility of the system. In some embodiments, for example, the proximal coupler, the ring that can be attached to the distal end of the outer tube, can be used to organize the tools and endoscope in a particular arrangement to facilitate a particular positioning of the tools as they emerge from the shaft into the working space created by the retractor. In some embodiments, the tool channels can be placed further than the endoscope from the retractor elements that expand the most. Likewise, the proximal end of the outer tube can also have respective openings for each of the channels, and these openings can be, for example, a part of a handle coupler, or the handle itself, operably connecting one or more of the channels to the outer tube. The operable connection between the outer tube and channels can provide a means for controlling the

endoscope and tools, for example, from outside the patient. The rings can be made of any material believed by one of skill to be suitable for the purposes discussed herein. For example, the rings can be made of stainless steel, or perhaps a plastic such as polycarbonate or acrylonitrile butadiene styrene (ABS).

It should be appreciated that, in some embodiments, the systems taught herein can include any combination of components, the selected combination of which is designed to be operable with components that are obtained separate from the system. For example, the system can include an outer tube and a retractor component, the outer tube being operable with at least one channel obtained separately and an endoscope obtained separately. Likewise, the system can include an outer tube, a retractor, and an endoscope, and the channels are obtained separately; or an outer tube, a retractor, and a channel, the endoscope obtained separately. Moreover, the system can include an outer tube, a retractor, an endoscope, and at least one channel; or, a handle, an outer tube, a retractor, an endoscope, at least one channel, and at least one tool.

The terms "substantial," and "substantially" can be used, for example, to refer to a relative measure for a parameter. It can be used in some embodiments, for example, to refer to a degree of change or function that relates to an amount, a performance, or some other characteristic. The following are for purposes of example in describing general embodiments: As described, the systems can be considered to be floating systems, can have a floating channel, a floating endoscope, multiple floating channels, or a combination thereof, in some embodiments. For example, the phrase, "an at least substantially floating arrangement within the system", can refer to an arrangement, for example a channel or endoscope arrangement, that can have some attachment that restricts movement in at least one direction, a minimal attachment to minimize such restriction of movement, or perhaps no attachment at all, to another system component. For example, a channel or endoscope can be arranged to be at least substantially floating in the outer tube relative to a second such system that does not use a floating-type arrangement to increase flexibility, or inherently achieve an increase in flexibility, of the second such system. As such, in many embodiments, the endoscope and/or channel can have a substantial portion of its arrangement unattached within the system, allowing the substantial portion to "float" or move substantially freely within the outer tube. The "substantial portion" can be, for example, a percentage of the arrangement that must remain unattached within the system to provide a performance characteristic, such as an increased flexibility of the system when compared to the second such system that does not use a floating-type arrangement to increase flexibility, or inherently achieve an increase in flexibility, of the second such system.

The phrase, "at least substantially render the target tissue aperistaltic for the treatment", for example, can refer to the target tissue having some minimal peristalsis, or perhaps no peristalsis, under the conditions of normal use to provide a performance characteristic, such as controlling movement of the target tissue to facilitate treatment. The phrase, "at least substantially attached", for example, "at least substantially attached to the lumen of the outer tube", for example, can refer to a component having a fixed attachment or moveable attachment. In some embodiments, the attachment can be between the component and the lumen, such that there is a loss of at least one degree of freedom of movement of the component. For example, the component can slide and/or rotate in relation to the lumen of the outer tube, as long as

the sliding and/or rotating occur in relation to a particular fixed point on the lumen. Likewise, "at least substantially attached" can, of course, mean "fixed", "reversibly fixed," or the like, in some embodiments. Likewise, "at least slidably-attached" can refer to an attachment between components that allows for at least sliding motion between components such as, for example, a sliding motion between a port and a tube. In some embodiments, an endoscope can be at least slidably-attached, for example, where the scope is allowed to slide in the direction of the scope's central axis in and out of a port, such that the distance that the scope extends beyond the port is adjustable. And, in some embodiments, a component can be "at least slidably-attached" where it can slide as well as move in other directions. For example, the port can be substantially larger than the scope, in some embodiments, such that the scope can slide axially, as well as move side-to-side, align its central axis parallel to the central axis of the outer tube, or perhaps, misalign its central axis to not be parallel to the central axis of the outer tube.

The phrase, "at least substantially increases the flexibility" can refer to an orientation of components that enhances the flexibility of a system when compared to another orientation and design of the components. For example the phrase "at least substantially increases the flexibility of the system over a second such system" can refer to a comparison of flexibility of the claimed system over the second system not having the floating arrangement under the conditions of normal use, such that the flexibility of the system has increased to a minimal amount that improves the ease of positioning the system in the subject for the treatment of the target tissue.

The phrase, "at least substantially rigid component," can refer a component that is rigid, or sufficiently rigid such that the desired function is obtained, under the forces that are created with normal use. For example, a desired function may be to prevent or inhibit the occurrence of a bending moment of the rigid component at one or more points along the length of a retractor upon expansion of the retractor in the subject. In some embodiments, the systems taught herein can have a retractor with four retractor elements, at least two of which are expandable in the subject to create a working space for a treatment. In this example, the expansion of the at least two retractor elements toward the target tissue to create the working space requires a force sufficient to retract the tissue and, creates an opposing force in the opposite direction that can create the bending moment in the rigid component. One of skill should appreciate that such a bending moment can be problematic, for example, where it contributes to an instability that affects the user's control over the position of the retractor during a treatment of the target tissue. In such embodiments, a component that prevents or inhibits the bending moment can be "at least substantially rigid," for example, where the user retains a desired level of control, or at least sufficient control, over the position of the retractor during the retraction of the target tissue. In some embodiments, a component that prevents or inhibits a bending moment, whether in or out of the subject, can be at least substantially rigid where the bending of the component due to the expansion of the retractor creates a deflection that ranges from 0.0 to about 5 degrees, about 1.0 degree to about 10 degrees, about 2.0 degrees to about 12 degrees, about 3.0 degree to about 10 degrees, about 1.0 degree to about 15 degrees, about 1.0 degree to about 9.0 degrees, about 1.0 degree to about 8.0 degrees, about 1.0 degree to about 7.0 degrees, about 1.0 degree to about 6.0 degrees, about 1.0 degree to about 5.0 degrees, about 1.0

degree to about 4.0 degrees, or any range therein in increments of about 0.1 degree. In some embodiments, the deflection of the rigid component cannot exceed about 1.0 degree, about 2.0 degrees, about 3.0 degrees, about 4.0 degrees, about 5.0 degrees, about 6.0 degrees, about 7.0 degrees, about 8.0 degrees, about 9.0 degrees, about 10.0 degrees, or any 0.1 degree increment therein. The bending can be measured, for example, as a point of deflection from the original position of the rigid component's axis from force created on the rigid component through the expansion.

The terms "substantial" or "substantially" can be used interchangeably in some embodiments, and can be described using any relative measures acceptable by one of skill. For example, relative percentages can be used to indicate a substantial amount, substantial change, substantial difference, substantial function, or the like. In some embodiments, the percentage can be greater than 10%, greater than 20%, greater than 30%, greater than 40%, or greater than 50%. In some embodiments, the percentage can be greater than 60%, greater than 70%, or greater than 80%. And, in some embodiments, the percentage can be greater than 90%, greater than 95%, or in some embodiments, even greater than 99%. For example, a substantial [amount]" or a "substantial [change]", can include any amount or change relative to a reference parameter. The amount or change, for example, can include an increase or decrease relative to the reference parameter, can be compared to a reference point for the parameter. The deviation from the reference point can be, for example, in an amount of at least 1%, at least 2%, at least 3%, at least 5%, at least 10%, at least 15%, at least 20%, at least 25%, at least 30%, at least 35%, at least 40%, at least 45%, or any 1% increment therein. Also, for example, a "substantial [function]" or "substantially [functioning]" limitation can serve as a comparison to a reference function parameter, to indicate a deviation that will still provide the intended function. Reference functions can include, for example, floating, aperistalsis, attaching, flexing, rigidity, a position or positioning relative to another object, and the like. The deviation from the reference point can be, for example, in an amount of less than 1%, less than 3%, less than 5%, less than 10%, less than 15%, less than 20%, less than 25%, less than 30%, less than 35%, less than 40%, less than 45%, or any 0.1% increment therein. For example, a component can have an acceptable, substantial [function] when it deviates from the reference by less than the acceptable deviation.

As such, the system can include a floating, multi-lumen-catheter retractor system for ease of positioning in a subject, and such systems can be designed to provide a minimally invasive treatment of the subject. In some embodiments, the systems comprise a highly flexible outer tube configured for guiding a floating channel and a floating endoscope in an at least substantially floating arrangement within the system. This flexible outer tube can have a lumen, a proximal end, and a distal end. And, during a use of the system, the floating channel can serve as a guide through which a tool is manipulated in a treatment of a target tissue in a subject. In some embodiments, the tool can include a grasper, a forcep, a scissor, a knife, a dissector, an endoscopic stapler, a tissue loop, a clip applier, a suture-delivering instrument, or an energy-based tissue coagulator or cutter. And, in some embodiments, the floating channel can have an elevator component for moving a bendable section to manipulate the tool. In some embodiments, at least one channel and/or the endoscope can have at least substantial freedom to move within the outer tube during operation, or "float," such that

the system can be considered to be a floating, multi-lumen-catheter retractor system as taught herein.

Likewise, the system can also comprise a stable, yet dynamic operative environment in that it can include a reversibly-expandable retractor that expands to form a treatment space in the subject. The retractor can be configured, for example, for the expansion to occur distal to the distal end of the outer tube and at least substantially render the target tissue aperistaltic for the treatment; wherein, during a use of the system in a subject, the floating channel can be at least substantially attached to the lumen of the outer tube at a first proximal location and a first distal location, and be at least substantially floating in the lumen of the outer tube between the first proximal location and the first distal location. Likewise, during the use of the system, the floating endoscope can be at least slidably-attached to the lumen of the outer tube at a second proximal location and a second distal location, and be at least substantially floating in the lumen of the outer tube between the second proximal location and second distal location. And, during the use of the system, the at least substantially floating arrangement can at least substantially increase the flexibility of the system over a second such system, the second such system having a lumen for a tool and an endoscope affixed to the lumen throughout the length of the outer tube between the proximal end and the distal end of the outer tube. The increased flexibility of the at least substantially floating arrangement can facilitate an ease of positioning the system in the subject for the treatment of the target tissue. Moreover, the retractor can be a reversibly-stabilized and reversibly-expandable retractor, retractor forming an asymmetrical treatment space upon the expansion. And, the retractor can be configured to reversibly stiffen an otherwise flexible arrangement of the retractor, the flexible arrangement designed to facilitate the ease of positioning of the system in the subject and to reversibly stiffen for the expansion of the retractor.

FIGS. 2A and 2B illustrate how a system as taught herein can be positioned for treating a lesion in the ascending colon, according to some embodiments. It should be appreciated that any series of steps and methods known to one of skill to be useful in the positioning 200 can be used with systems taught herein. FIG. 2A illustrates how an endoscope 215 can be used to locate the lesion, a target tissue 290 in a portion of the ascending colon 295. FIG. 2B illustrates how the multi-lumen-catheter retractor system 201 can be guided to the target tissue 290 using the endoscope 215 as a guide for the positioning 200 of the system in the treatment of the target tissue 290.

FIGS. 3A-3L illustrate how a system as taught herein can be used in removing a lesion in a colon, according to some embodiments. The system can be positioned as in FIGS. 2A and 2B in the treatment 300 of a gastrointestinal lesion 390, and a multidirectional and multi-angular approach to the lesion can be used. As in FIGS. 2A and 2B, for example, the approach can include identifying a lesion in a gastrointestinal lumen of a subject using an endoscope 315; and, forming a substantially rigid and stable endoluminal working area for treating a target tissue, the gastrointestinal lesion 390. In FIG. 3A, the system is positioned at the lesion 390, and in FIG. 3B, the expandable retractor 350 expands to create an asymmetrical working space 360.

FIGS. 3C and 3D illustrate the creation of the working space 360, and manipulation of the endoscope 315 and tools 320,325. After positioning the retractor 350 in proximity to the lesion 390, the retractor 350 is expanded to form the asymmetrical working space 360 for the treating of the

lesion 390. The system can have any configuration taught herein, such as (i) at least one independently manipulable-and-articulate scope 315 to be used in viewing the lesion 390, (ii) at least one tool channel 310 for at least one independently manipulable-and-articulate tool 320,325 to be used in the treating of the lesion 390, and (iii) the retractor 350, which can be an asymmetrically expandable structure. In some embodiments, the retractor 350 can be expanded asymmetrically toward the lesion 390, the expanding including a portion of the retractor 350 pushing on tissue surrounding the lesion 390 to increase the working area by providing an asymmetrical working area and thus facilitate an entry of the lesion 390 into the working area 360 for the treating. The retractor 350 can be located distal to the distal end of the outer tube 305 and the asymmetrical working area 360 can be substantially rigid and stable relative to the independently manipulable-and-articulate scope 315 and the at least one tool 320,325 to facilitate treating the lesion 390. The treating of the lesion 390 can include, for example, (i) viewing the lesion 390 with the articulating scope 315 and (ii) using the at least one tool 320,325 in the treatment of the lesion 390 with a multidirectional and multi-angular approach to the lesion 390 in the asymmetrical working area 360.

In some embodiments, the independently manipulable-and-articulate scope 315 and the at least one tool 320,325 can be independently movable axially in the working area 360, independently rotatable in the working area 360, and independently bendable in at least one direction in the working area 360. Accordingly, in some embodiments, the portion of the retractor 350 pushing on the tissue surrounding the lesion 390 can be expanded further from the central axis 307 of the distal end of the outer tube 305 than other portions of the retractor to provide an even larger working area 360 for the treating of the lesion 390 when compared to a second such structure that merely expands symmetrically around the central axis 307 of the distal end of the outer tube 305.

FIG. 3E illustrates a multidirectional and multi-angular approach to the lesion 390, showing the step of positioning the work area 360, endoscope 315, and tools 320,325 in relation to the lesion 390. After the retractor 350 is expanded, the user of the system can view and approach the lesion 390 with the tools 320,325 from nearly any desired angle within the working space 360. FIG. 3F illustrates the versatility of the system, showing the step of removing the lesion 390 using tool 320 to excise the lesion 390 from an independently chosen first angle, while tool 325 can be used to grasp the lesion 390 from an independently chosen second angle and endoscope 315 can be used to view the lesion 390 from an independently chosen third angle. After the excision of the lesion 390 from the gastrointestinal tract 395, a tissue defect 397 remains. FIG. 3G illustrates the step of releasing the excised lesion 390 into the retractor assembly in preparation for completion of the procedure. FIGS. 3H and 3I illustrate the step of closing the tissue defect 397, showing that tool 320 for excision of the lesion 390 has been replaced by tool 322 for closure of the lesion. FIGS. 3J and 3K illustrate the steps of capturing the lesion 390 for removal using tool 323 and collapsing the retractor 350 in preparation for removal of the system from the subject, including the use of an optional retractor cover 355. FIG. 3L is a view of the closed tissue defect following completion of the treatment.

In some embodiments, as shown for example in FIGS. 3B-3J, the system can comprise a stable, yet dynamic operative environment in that it can include a reversibly-



expandable retractor **350** that expands to form a treatment space **360** in the subject. The retractor **350** can be configured, for example, for the expansion to occur distal to the distal end **308** of the outer tube **305**. In some embodiments, the retractor can at least substantially render the target tissue **390** aperistaltic for the treatment. The retractor **350** can have a variety of configurations to serve, for example, as a scaffolding within the gastrointestinal tract **395**. For example, the retractor **350** can include retractor elements **351,352,353,354**, along with a proximal coupler **398** operably connected to the retractor elements **351,352,353,354**, whether at least substantially attached and/or at least slidably-engaged to the retractor elements **351,352,353,354**, and a distal nexus **399** for a distal point of an operable connection with the retractor elements **351,352,353,354**. The distal nexus **399** is shown in the shape of a ring, although it can be virtually any shape desirable to one of skill, such as a cone, hemisphere, sphere, and the like, and it may or may not include a port for passage of the endoscope beyond the distal end of the system.

Moreover, the retractor **350** can be a reversibly-stabilized and reversibly-expandable retractor, the retractor **350** forming an asymmetrical treatment space **360** upon the expansion. And, the retractor **350** can be configured to reversibly stiffen an otherwise flexible arrangement of the retractor **350**, the arrangement designed to facilitate ease of positioning of the system **300** in the subject and to reversibly stiffen for the expansion of the retractor **350**. The stabilization of the retractor **350** can, in some embodiments, include a means for stabilizing the retractor **350** through a stabilizer subsystem as taught herein, the stabilizer having, for example, an at least substantially-rigid beam **375** to support the expanded retractor **350**.

FIGS. 4A-4E illustrate details of a system as taught herein, in side, axial, and oblique views of expanded and collapsed configurations, and including a stabilizer subsystem, according to some embodiments. The figures illustrate an example of a multi-lumen catheter system having a reversibly-stabilized and reversibly-expandable retractor for a minimally invasive treatment of a subject. FIGS. 4A-4C illustrate side and axial views that show that the system **400** can comprise a flexible outer tube **405** for guiding a channel (not shown) and an endoscope (not shown) within the system **400**. The flexible outer tube **405** has a lumen, a proximal end (not shown), and a distal end **408**. The channel (not shown) serves as a guide through which a tool (not shown) can be manipulated in a treatment of a target tissue in a subject. In some embodiments, the retractor **450** can be a reversibly-stabilized and reversibly-expandable retractor **450** forming a treatment space upon expansion and configured for the expansion to occur distal to the distal end **408** of the outer tube **405**. The retractor **450** can be designed to reversibly-stiffen an otherwise flexible arrangement of the retractor **450**, the flexible arrangement designed to facilitate the positioning of the system in the subject and to reversibly-stiffen for the expansion of the retractor **450**. In these embodiments, the reversibly-stiffened arrangement of the retractor **450** can form an at least substantially-rigid beam **475** from an otherwise flexible beam **470** as a structural support for the expansion of the retractor **450**. In some embodiments, the stabilizer subsystem can include the flexible beam **470**, which may comprise a flexible tube, and a means for creating the at least substantially-rigid beam **475**. The means, as taught herein, can include all embodiments taught herein, including the mechanisms for slidably-engaging an at least substantially-rigid rod or beam, for example, within the flexible rod or beam **470** prior to expanding the

retractor. In some embodiments, the terms “rod” and “beam” can be used interchangeably and, in some embodiments, the terms “beam” and “tube” can be used interchangeably.

In some embodiments, the flexible beams taught herein can comprise a polymer, such as polyimide, polyether block amides (PEBAX), nylon, polyethylene, polyurethane, polyvinylchloride (PVC), PEEK, or polytetrafluoroethylene (TEFLON). One of skill will appreciate that the flexible beams can be reinforced tubes made from components and designs known to the art. The flexible beam can be, for example, a flexible tube that is reinforced with metal wires, braids, or coils that include, for example, a metal such as a stainless steel or NITINOL. In some embodiments, the flexible tube can be kink resistant and transmit torque. And, in some embodiments, the flexible tube can comprise a combination of both flexible sections and rigid sections. In these embodiments, a flexible section can lie-between rigid sections, for example. Such flexible tubes can include composites of overlapping tubes joined using any method known to one of skill, including bonding using epoxy or cyanoacrylates, in some embodiments.

In some embodiments, any of the systems taught herein can include a bridge member to add stability to the retractor. For example, bridge member **444** is configured to maintain a desired orientation of the retractor elements **451,452,453,454** during the expansion, the bridge member **444** operably stabilizing at least two **451,452** of the four retractor elements **451,452,453,454**. Moreover, in some embodiments, each of the systems taught herein can have an outer tube that is wire-reinforced, such as mesh, braided, or the like, to provide kink resistance and torqueability to the system, as well as to further facilitate a positioning of the system in the subject.

FIGS. 4D and 4E illustrate oblique views of the system **400** in collapsed and expanded configurations. The multi-lumen concept is presented with clarity in these figures, showing multiple lumens **406a,406b,406c** in the system **400**. Lumen **406a** can contain an endoscope (not shown), lumen **406b** can contain a first working channel **410b** for a first tool (not shown), and lumen **406c** can contain a second working channel **410c** for a second tool (not shown). FIG. 4D in the collapsed configuration has a flexible beam **470**, whereas FIG. 4E in the expanded configuration has a rigid beam **475** that was formed from the flexible beam. A rigid beam can be formed from a flexible beam, in some embodiments, by slidably inserting a rigid rod into a flexible tube that composes the flexible beam. In many embodiments, the term “tool channel” can be used interchangeably with the term “working channel.” And, in some embodiments, a channel can be a separate component placed inside the outer tube, or it can be a space remaining in the lumen of the outer tube between separate components that were placed in the outer tube, the separate components including, for example, an endoscope, a working channel, an instrument, a guide, and the like.

In some embodiments, as shown for example in FIGS. 4A-4E, the system can comprise a stable, yet dynamic operative environment in that it can include a reversibly-expandable retractor **450** that expands to form a treatment space **460** in the subject. The retractor **450** can be configured, for example, for the expansion to occur distal to the distal end **408** of the outer tube **405**. In some embodiments, the retractor can at least substantially render the target tissue **490** aperistaltic for the treatment. The retractor **450** can have a variety of configurations to serve, for example, as a scaffolding within the gastrointestinal tract **495**. For example, the retractor **450** can include retractor elements

451,452,453,454, along with a proximal coupler 498 operably connected to the retractor elements 451,452,453,454, whether at least substantially attached and/or at least slidably-engaged to the retractor elements 451,452,453,454, and a distal nexus 499 for a distal point of an operable connection with the retractor elements 451,452,453,454.

Moreover, the retractor 450 can be a reversibly-stabilized and reversibly-expandable retractor, the retractor 450 forming an asymmetrical treatment space 460 upon the expansion. And, the retractor 450 can be configured to reversibly stiffen an otherwise flexible arrangement of the retractor 450, the arrangement designed to facilitate ease of positioning of the system 400 in the subject and to reversibly stiffen for the expansion of the retractor 450. The stabilization of the retractor 450 can, in some embodiments, include a means for stabilizing the retractor 450 through a stabilizer subsystem as taught herein, the stabilizer having, for example, an at least substantially-rigid beam 475 to support the expanded retractor 450.

FIGS. 5A-5D illustrate side and top views of a system as taught herein, having side views and top views of expanded and collapsed configurations, according to some embodiments. FIGS. 5A and 5B illustrates side views of system 500 in collapsed and expanded configurations showing an example of an asymmetric work space that can be formed during an endoscopic procedure using the system 500. And, as shown in FIG. 5B, the expansion can occur in a disproportionately greater amount on the luminal side 559 of the rigid beam 575 than the abluminal side 557 of the rigid beam 575 to increase the treatment, or working, space 560, the treatment space 560 having a volume that is asymmetrically distributed around the rigid beam 575. In some embodiments, the expansion can occur in an amount that is at least 5× greater on the luminal side 559 of the rigid beam 575 than the abluminal side 557 of the rigid beam 575. And in some embodiments, the expansion can be at least 1.1× greater, at least 1.3× greater, at least 1.5× greater, at least 2.0× greater, at least 2.5× greater, at least 3.0× greater, at least 3.5× greater, at least 4.0× greater, at least 4.5× greater, at least 5.0× greater, at least 5.5× greater, at least 6.0× greater, at least 6.5× greater, at least 7.0× greater, at least 7.5× greater, at least 8.0× greater, at least 8.5× greater, at least 9.0× greater, at least 9.5× greater, at least 10.0× greater, or any 0.1× increment within this range, on the luminal side of the beam than the abluminal side of the beam.

In some embodiments, as shown for example in FIGS. 5A-5D, the system can comprise a stable, yet dynamic operative environment in that it can include a reversibly-expandable retractor 550 that expands to form a treatment space 560 in the subject. The retractor 550 can be configured, for example, for the expansion to occur distal to the distal end 508 of the outer tube 505. In some embodiments, the retractor can at least substantially render the target tissue 590 aperistaltic for the treatment. The retractor 550 can have a variety of configurations to serve, for example, as a scaffolding within the gastrointestinal tract 595. For example, the retractor 550 can include retractor elements 551,552,553,554, along with a proximal coupler 598 operably connected to the retractor elements 551,552,553,554, whether at least substantially attached and/or at least slidably-engaged to the retractor elements 551,552,553,554, and a distal nexus 599 for a distal point of an operable connection with the retractor elements 551,552,553,554.

Moreover, the retractor 550 can be a reversibly-stabilized and reversibly-expandable retractor, the retractor 550 forming an asymmetrical treatment space 560 upon the expansion. And, the retractor 550 can be configured to reversibly

stiffen an otherwise flexible arrangement of the retractor 550, the arrangement designed to facilitate ease of positioning of the system 500 in the subject and to reversibly stiffen for the expansion of the retractor 550. The stabilization of the retractor 550 can, in some embodiments, include a means for stabilizing the retractor 550 through a stabilizer subsystem as taught herein, the stabilizer having, for example, an at least substantially-rigid beam 575 to support the expanded retractor 550.

FIGS. 6A-6D illustrate side views of a system as taught herein having side views and cross-sections of expanded and collapsed configurations of the system, according to some embodiments. The figures illustrate an example of a multi-lumen catheter system having a reversibly-stabilized and reversibly-expandable retractor for a minimally invasive treatment of a subject. FIGS. 6A and 6B illustrates a side view that shows that the system 600 can comprise a flexible outer tube 605 for guiding a channel (not shown) and an endoscope (not shown) within the system 600. The flexible outer tube 605 has a lumen, a proximal end (not shown), and a distal end 608. The channel (not shown) serves as a guide through which a tool (not shown) can be manipulated in a treatment of a target tissue in a subject. In some embodiments, the retractor 650 can be a reversibly-stabilized and reversibly-expandable retractor 650 forming a treatment space 660 upon expansion and configured for the expansion to occur distal to the distal end 608 of the outer tube 605. The retractor 650 can be designed to reversibly-stiffen an otherwise flexible arrangement of the retractor 650, the flexible arrangement designed to facilitate the positioning of the system in the subject and to reversibly-stiffen for the expansion of the retractor 650. In these embodiments, the reversibly-stiffened arrangement of the retractor 650 can form an at least substantially-rigid beam 675 from an otherwise flexible beam 670 as a structural support for the expansion of the retractor 650.

Handle 680 includes entry ports for operatively combining the system with external components, such as an entry port 609 for an endoscope (not shown) and/or a tool (not shown). The handle is also operatively connected to the proximal end of the outer tube 605 and can have exit ports from the handle 680 into the outer tube 605. The system can include a stabilizer subsystem, in some embodiments. For example, a stabilizer actuator 612 can be included on the handle 680 to reversibly-stiffen the flexible beam 670 to create the at least substantially-rigid beam 675 for the expansion of the retractor 650. A retractor actuator 614 can be included on the handle 680 to reversibly expand the retractor 650.

FIGS. 6D and 6E illustrate oblique views of the system 600 in expanded configurations. The expanded configurations have a rigid beam 675 that was formed from the flexible beam that is typically present in the collapsed state for positioning in the subject. The rigid beam 675 can be formed from a flexible beam, in some embodiments, by slidably inserting a rigid rod into a flexible tube that composes the flexible beam. As shown in FIGS. 6B and 6D, the stabilizer actuator 612 is operably connected to the rigid rod 672 through a rod coupler 613. Likewise, the retractor actuator 614 is operably connected to a retractor element 651,652 through an element coupler 611. The stabilizer actuator 612 and/or the retractor actuator 614 can be reversibly engageable with the handle 680, in some embodiments, such that the stabilizer actuator 612 and/or the retractor actuator 614 can be reversibly-fixed in position relative to the handle 680. In some embodiments, the stabilizer actuator 612 and/or the retractor actuator 614 can be multi-positional,

having at least three positions for expansion and/or collapse of the retractor. In some embodiments, the stabilizer actuator **612** and/or the retractor actuator **614** can have a plurality of ratchet teeth **616** to provide a plurality of positions for reversibly-fixing the retractor in position during expansion or collapse of the retractor.

One of skill will appreciate that the handle can be any of a variety of shapes to provide a desired or ergonomic position for operation of the system. By way of example, the retractor actuator can be configured as a finger-activated button on the handle **680** that slides back and forth through a slot in the handle **680** to expand or collapse the retractor elements. A means for dynamically adjusting or ratcheting the retractor position can be provided along the handle slot to lock the position of the retractor elements in place when the retractor actuator button is not pressed. A button on the opposite side of the handle can be operatively connected to the stabilizer subsystem to convert the flexible beam into a rigid beam, or convert the rigid beam into a flexible beam. The handle can have inner channels routed axially, for example, within the body of the handle and in communication with ports for tools and endoscope introduction into the outer tube. In some embodiments, the handle can be configured to require that the stabilizer actuator is activated before the retractor actuator can be activated, serving as a "safety" mechanism in the operation of the system.

As such, in some embodiments, as shown for example in FIGS. **6A-6D**, the system can comprise a stable, yet dynamic operative environment in that it can include a reversibly-expandable retractor **650** that expands to form a treatment space **660** in the subject. The retractor **650** can be configured, for example, for the expansion to occur distal to the distal end **608** of the outer tube **605**. In some embodiments, the retractor can at least substantially render the target tissue **690** aperistaltic for the treatment. The retractor **650** can have a variety of configurations to serve, for example, as a scaffolding within the gastrointestinal tract **695**. For example, the retractor **650** can include retractor elements **651,652,653,654**, along with a proximal coupler **698** operably connected to the retractor elements **651,652,653,654**, whether at least substantially attached and/or at least slidably-engaged to the retractor elements **651,652,653,654**, and a distal nexus **699** for a distal point of an operable connection with the retractor elements **651,652,653,654**.

Moreover, as described herein, the retractor **650** can be a reversibly-stabilized and reversibly-expandable retractor, the retractor **650** forming an asymmetrical treatment space **660** upon the expansion. And, the retractor **650** can be configured to reversibly stiffen an otherwise flexible arrangement of the retractor **650**, the arrangement designed to facilitate ease of positioning of the system **600** in the subject and to reversibly stiffen for the expansion of the retractor **650**. The stabilization of the retractor **650** can, in some embodiments, include a means for stabilizing the retractor **650** through a stabilizer subsystem as taught herein, the stabilizer having, for example, an at least substantially-rigid beam **675** to support the expanded retractor **650**.

The rigid rod can be a straight component comprising a rigid material, for example stainless steel or another metal or alloy, that is slide-able in and out of the inner diameter of the flexible tube. As such, the stabilizer subsystem can have a flexible beam or rigid beam by sliding the rigid rod proximal (i.e., anally) to the flexible tube by pulling back on the rigid rod through a mechanism operably connected to the handle. The rigid rod can be pushed forward (i.e., orally) into the flexible tube to stiffen and straighten the flexible tube. By pushing the rigid rod across the length of the flexible tube,

the flexible tube, or flexible beam, becomes rigid and straight, and in effect renders the whole retractor structure at least substantially rigid and straight. One of skill in the art will appreciate that any mechanism of reversibly stiffening a flexible component in vivo may be used in some embodiments. For example, the flexible tube, or flexible beam, may also comprise a series of rigid tubes having a flexible, non-stretchable cable passing through the lumens of the tubes. When the cable is relaxed, the series of rigid tubes can be separated using, for example, a compressible component such as a spring between each of the series of rigid tubes to provide a flexible non-overlapping configuration. When the cable is tensioned, the compressible components compress, and the rigid tubes overlap, converting the flexible beam into a rigid beam.

The reversibly-stabilized retractor, as described herein, is useful in positioning the working space at the site of treatment of the target tissue as it can be rendered flexible for positioning and later rendered rigid for expansion of the retractor. During introduction of a system taught herein into a tortuous body lumen, for example a colon, the retractor can be unexpanded and flexible. This flexibility allows the retractor to bend to conform to the bends in the tortuous body lumen, so that it can be advanced with ease and not cause trauma to the lumen. The rings which hold the retractor elements together can also have lumens that allow passage of a guide such as an endoscope. In such embodiments, when the retractor is in the flexible mode for introduction, for example, the rings can be free to slide over the guide as the system is advanced forward. In some embodiments, the lumens of the rings can be large enough relative to the diameter of the guide to allow for tilting and translation of the system on the guide, helping the system conform to the bends of the guide during advancement of the system orally or anally. Once the retractor is advanced to the target location in the lumen, the flexible beam of the retractor can be straightened and stiffened as described herein. Since the system can be flexible and torsionally stiff, the proximal shaft or the handle can be easily rotated as desired relative to the location of the target lesion.

The retractor elements can have at least one pair that is pre-shaped having peaks pointing outwards at a desired angle. In some embodiments, the angle can range from about 45 degrees to about 135 degrees, about 60 degrees to about 120 degrees from each other on one side of the rigid beam, the vertex of the angle being the central axis of the rigid beam, as can be seen in the figures provided herein. In some embodiments, the angle is about 90 degrees between retractor elements. Upon expansion, the retractor elements bulge outwards on one side disproportionately more than the other retractor elements, resulting in an asymmetrical expansion of the retractor. The at least substantially rigid beam prevents or inhibits deformation of the retractor during creation of forces on the retractor in the expansion. The forces include forces from expanding tissue outwards asymmetrically, as well as the initial forces applied on the retractor elements to create an asymmetrical working space.

In some embodiments, the target lesion can be located on the side of the most expanded retractor elements so to facilitate maximizing or increasing the distance between the lesion to be treated and the portals at which the endoscope and tools are introduced into the working space. The endoscope and tools can be maneuvered independently, for example, to access the lesion at a greater range of angles than is currently clinically obtainable using state-of-the-art systems. This increased maneuverability can improve the view of the lesion and ability to manipulate and dissect the

lesion. For example, a grasper can be advanced out of the instrument channel into the working space and flexed towards the polyp, grasp the polyp and retract the tissue to expose the base of the polyp for dissection by a dissection tool through the multi-channel systems taught herein. Sometimes, it can also be desired to reduce the distance between the lesion to be treated and the portals at which the endoscope and tools are introduced into the working space. For example, it can be desired to locate the lesion on the side of the least expanded retractor elements to better align the lesion with the endoscope channel substantially parallel to the lumen wall. Such a configuration may be clinically optimal while the polyp is retracted by a grasper towards the most expanded side. In such embodiments, a dissection tool can be advanced through a channel at the base of the polyp and dissect the polyp's base where it attaches to the lumen wall, while the position of the endoscope provides a close view of the base of the polyp to help identify the desired margin for dissection.

In some embodiments, any of the systems taught herein can include a bridge member, which provides structural support to add stability to the retractor. The bridge member can include any configuration conceivable by one of skill to provide additional support, such as a scaffolding means, for enhancing or buttressing the stability and rigidity of the expanded contractor. For example, bridge member **644** is configured to maintain a desired orientation of the retractor elements **651,652,653,654** during the expansion, the bridge member **644** operably stabilizing at least two **651,652** of the four retractor elements **651,652,653,654**. Moreover, in some embodiments, each of the systems taught herein can have an outer tube, for example outer tube **605**, that is wire-reinforced, such as mesh, braided, or the like, to provide kink resistance and torqueability to the system, as well as to further facilitate a positioning of the system in the subject. In some embodiments, the bridge member **644** can be configured to reduce drag from surrounding tissue during use. For example, as shown in FIGS. **6A** and **6B**, the bridge member **644** can be configured to facilitate a movement of the system in a gastrointestinal tract by designing the bridge member **644** to include a forward component **644a** that is inclined to facilitate forward movement orally, and a reverse component **644b** that is inclined to facilitate reverse movement anally.

The bridge member can be connected to the retractor elements, for example, to maintain a desired orientation of the retractor elements as they expand against a gastrointestinal tissue, for example. As the retractor is expanded, the bridge member is also expanded outward. In some embodiments, the bridge member is operably connected only to the retractor elements that expand the most, for example the retractor elements **751,752** in FIG. **7**, which can be the members that incur the most induced forces on the retractor due to the disproportionate pressure applied to create the asymmetrical working space in the expansion. In some embodiments, the bridge can be designed to flex to prevent the retractor elements from collapsing towards each other or bending away from each other, while also providing some spring or elasticity to the system to comply gently with the tissue. One of skill will appreciate that the bridge can comprise any suitable material that provides the material characteristics desired. For example, the bridge can be formed from a curved nitinol wire in some embodiments. The ends of the nitinol wires can be connected to the retractor elements using any manufacturing process deemed

suitable by one of skill for the in vivo uses taught herein, such process including, for example, tubing connectors, adhesives, or solder.

FIG. **7** illustrates a cutaway view of the distal end of the outer tube of a system as taught herein, showing components of the expansion and collapse of the retractor, according to some embodiments. The figure illustrates the distal end **708** of outer tube **705**. The distal end **708** includes a slot guide **755** to control the orientation of an expanding retractor element **751**, as well as a port **754a** for operably receiving/supporting a lower retractor element **754**. Likewise, a lumen **706c** can be provided to contain a working channel **710c**. The lumen **706** of the outer tube **705** can also be used to guide an endoscope (not shown) through port **706a**. Only a portion **751,754,770,772,775** of the retractor components is shown to partially describe the relation between the outer tube **705** and the retractor in some embodiments. The retractor can be configured, for example, for the expansion to occur distal to the distal end **708** of the outer tube **705**. For example, the retractor can include retractor elements **751,752** (not shown), **753** (not shown), **754**, along with a proximal coupler **798** operably connected to the retractor elements **751,752** (not shown), **753** (not shown), **754**, whether at least substantially attached and/or at least slidably-engaged to the retractor elements **751,752** (not shown), **753** (not shown), **754**. The retractor can be configured to reversibly stiffen an otherwise flexible arrangement of the retractor, the arrangement designed to facilitate ease of positioning of the system **700** in a subject and to reversibly stiffen for the expansion of the retractor in the subject. The stabilization of the retractor can, in some embodiments, include a means for stabilizing the retractor through a stabilizer subsystem as taught herein, the stabilizer having, for example, a flexible beam **770** that can be converted to an at least substantially-rigid beam **775**, using a means for slidably engaging a rigid, or substantially rigid, component **772** as taught herein in operable connection with the flexible beam **770**, to support the expanded retractor.

FIG. **8** illustrates the cutaway view of FIG. **7**, showing the distal end of the outer tube of a system as taught herein, in which components of the system can be floating in the outer tube to enhance flexibility for positioning the system in a subject, according to some embodiments. The figure illustrates the distal end **808** of outer tube **805**. The distal end **808** includes a slot guide **855** to control the orientation of an expanding retractor element **851**, as well as a lower retractor element **854**. Likewise, a lumen **806c** can be provided to contain a working channel **810c**. The lumen **806** of the outer tube **805** can also be used to guide an endoscope **815**. Only a portion **851,854,870,872,875** of the retractor components is shown to partially describe an embodiment of the relation between the outer tube **805** and the retractor. The retractor can be configured, for example, for the expansion to occur distal to the distal end **808** of the outer tube **805**. For example, the retractor can include retractor elements **851,852** (not shown), **853** (not shown), **854**, along with a proximal coupler **898** operably connected to the retractor elements **851,852** (not shown), **853** (not shown), **854**, whether at least substantially attached and/or at least slidably-engaged to the retractor elements **851,852** (not shown), **853** (not shown), **854**. The retractor can be configured to reversibly stiffen an otherwise flexible arrangement of the retractor, the arrangement designed to facilitate ease of positioning of the system **800** in a subject and to reversibly stiffen for the expansion of the retractor in the subject. The stabilization of the retractor can, in some embodiments, include a means for stabilizing the retractor through a

stabilizer subsystem as taught herein, the stabilizer having, for example, a flexible beam **870** that can be converted to an at least substantially-rigid beam **875**, using a means for slidably engaging a rigid, or substantially rigid, component **872** as taught herein in operable connection with the flexible beam **870**, to support the expanded retractor.

During a use of the system **800**, the working channel **810c** can be a floating channel that is (i) at least substantially attached to the lumen of the outer tube at a first proximal location (not shown) and a first distal location **806c** and (ii) at least substantially floating in the lumen **806** of the outer tube **805** between the first proximal location (not shown) and the first distal location **806c**. Likewise, during the use of the system **800**, the endoscope **815** can be a floating endoscope **815** that is (iii) at least slidably-attached to the lumen **806** of the outer tube **805** at a second proximal location (not shown) and a second distal location **806a** and (iv) at least substantially floating in the lumen **806** of the outer tube **805** between the second proximal location (not shown) and second distal location (**806a**). And, during the use of the system **800**, the working channel **810c** and the endoscope **815** also form separate floating components of a floating arrangement that (v) at least substantially increases the flexibility of the system **800** over a second such system having separate lumens for a tool and an endoscope, the separate lumens affixed to the lumen throughout the length of the outer tube between the proximal end and the distal end of the outer tube, the increased flexibility facilitating an ease of positioning the system **800** in the subject for the treatment of the target tissue. In some embodiments, the endoscope **815** can be at least slidably-attached to the distal end **808** of the outer tube **805** by inserting the endoscope **815** through a dedicated port (not shown) for the endoscope **815**, such that the system **800** is configured to be substantially limited to a sliding movement in and out of the distal end **808** of the outer tube **805**. And, in some embodiments, the endoscope **815** can be allowed to also float in a port **806a** that is substantially larger than the endoscope **815**, providing a sliding motion for the endoscope as well as room for side-to-side movements as well.

FIGS. **9A** and **9B** illustrate side views of working, and/or floating, channels that can be used to guide tools as taught herein, according to some embodiments. As discussed herein, the working channels can have at least a portion of which floats in the lumen of the outer tube in a manner that is the same or similar to FIG. **8** to further enhance the flexibility of the outer tube during position of the system in a subject. In some embodiments, the terms "channel," "floating channel," "working channel," and "tool channel" can be used interchangeably. Each working channel can be operatively connected to a handle **980** in a manner that is the same or similar to the operable connections taught herein for the retractor actuator and/or the stabilizer actuator. FIG. **9A** shows the tip **910a** of the working channel **910** in a substantially extended position, whereas FIG. **9B** shows the tip **910a** of the working channel **910** in a substantially bent position, such that the tip **910a** is deflected substantially normal to the central axis of the working channel **910**. A working channel system **900** consistent with other systems taught herein, for example, can include an entry port **908**, a working channel **910**, a wire coupler **911**, ratchet teeth **916**, a pull wire **917** for flexing or extending the tip **910a** of the working channel **910**, and wire actuator **919**. The ability to flex the tip **910a** of the working channel **910** facilitates independent positioning of a tool (not shown) in the treatment of a target tissue in a subject. In some embodiments, the wire actuator **919** can be multi-positional, having at least

three positions for bending tip **910a** of working channel **910**. In some embodiments, the wire actuator **919** can have a plurality of ratchet teeth **916** to provide a plurality of positions for reversibly-fixing the bent tip **910a** in position during use of the tool (not shown) in the treatment of the target tissue in the subject.

As described herein, the channels can be configured to control the trajectory and position of instruments such as forceps in the working space created by the retractor. In some embodiments, a channel can be removed from, or inserted through, the outer tube of the system, alone or inside an additional channel that may be used as a guide. The channels can be virtually any size considered by one of skill to be useful in the systems described herein. For example, a channel can have an inner diameter ranging from about 1 mm to about 5 mm, from about 2 mm to about 4 mm, from about 1 mm to about 3 mm, or any range therein. The length of the channel should, of course, complement the length of the system. For example, the channel can have a length ranging from about 40" to about 72", from about 48" to about 60", from about 42" to about 70", from about 44" to about 68", or any range therein in increments of 1".

The channels can also comprise any material or configuration known to one of skill to be suitable for the uses described herein. For example, the channels can comprise a single polymer layer, multiple polymer layers, a wire reinforced layer, or a combination thereof. In some embodiments, a channel can comprise (i) an inner layer of a polymer such as, for example TEFLON or polyethylene for slippery luminal surface on the inner diameter of the channel; (ii) a metal such as, for example, a stainless steel, nitinol, or cobalt chromium as a wire reinforcement in the configuration of a braid, mesh, or helical coil layer covering the inner layer; and, (iii) an outer layer of a polymer such as, for example, PEBAX, polyurethane, polyethylene, silicone, PVC, or nylon.

In some embodiments, the channels can be configured such that the outer layer (iv) is the most rigid in the proximal section of the channel (i.e., the first about 12" to about 24" of the channel), having a hardness of about 60 Shore D to about 80 Shore D; (v) has a medium stiffness in the middle section (i.e., the next about 12" to about 36" of the channel), having a hardness of about 50 Shore D to about 72 Shore D; and, (vi) is the most flexible in the distal section (i.e., the next about 0.5" to about 2" of the channel), having a hardness of about 20 Shore D to about 50 Shore D). The distal section of the channel can be the section that flexes and can be the distal about 1" of the channel, in some embodiments. In some embodiments, the channels can have a rigid section just proximal to the distal section to keep this flexible section straight when there is a bending moment on the tip such as when the instrument which is inserted through the channel is grasping a tissue during a gastrointestinal treatment, for example. The length of the rigid section of the channels can range, for example, from about 1 cm to about 10 cm, from about 2 cm to about 8 cm, from about 3 cm to about 7 cm, from about 4 cm to about 6 cm, about 6 cm, or any range therein in 1 cm increments. The rigid section can include a rigid tube comprising a reinforcement material such as, for example, stainless steel or NITINOL, or a polymer such as PEEK or a polyimide embedded between the outer polymer layer and the inner polymer layer. The rigid section can have any suitable length to perform its function in the system. In some embodiments, the rigid section can have a length ranging from about 0.001" to about 0.005".

The thickness of the inner layer of the channels can range from about 0.0005" to about 0.005", from about 0.001" to about 0.004", from about 0.002" to about 0.003", about 0.001", or any range therein in 0.0005" increments. The thickness of the reinforcement layer can range from about 0.001" to about 0.006", from about 0.002" to about 0.005", from about 0.003" to about 0.005", from about 0.001" to about 0.003", about 0.002", or any range therein in increments of 0.0005". The thickness of the outer layer can range from about 0.003" to about 0.012", from about 0.004" to about 0.010", from about 0.005" to about 0.009", from about 0.005" to about 0.008", about 0.010", or any range therein in increments of 0.001".

For flexing the distal end of the channel, there can be a side lumen with a pull wire embedded between the inner layer and the outer layer. In some embodiments, the side lumen can be located between the inner layer and the reinforcement layer, or the side lumen can be a part of the inner layer. The side lumen can be made of any material considered by one of skill to be useful in the systems taught herein. For example, the material can include a flexible tube of polymer such as, for example, TEFLON or polyethylene. In some embodiments, the side lumen runs parallel to the length of the channel in the distal section of the channel and then helical proximal to the distal section of the channel. The pitch of the helix can vary, for example, from about 1.0" to about 6.0", from about 2.0" to about 5.0", from about 1.0" to about 4.0", from about 3.0" to about 5.0", about 4.0", or any range therein in 0.1" increments. By routing the side lumen helically, the wire tension can be distributed all around the shaft so that the shaft can be rotated in any orientation smoothly and remain at least substantially stable. In some embodiments, the pull wire can run from the wire actuator in the handle into the side lumen, out of the distal end of the side lumen, and looped around a rigid ring. The rigid ring (stainless steel, 0.002-0.005" thick, 0.040"-0.25" long) at the distal end and back into the side lumen and out into the handle and attached to the wire actuator. The handle can be operatively connected to the channel, the handle having a housing, and a lumen in communication with the channel. The wire actuator is operatively attached to the pull-wire inside the housing with a button on the outside of the handle allowing the wire actuator to slide back (proximal) and forth (distal) on the handle to pull and push the pull-wire. Pulling the wire makes the tip flex and become rigid, whereas pushing the wire can make the tip relax and straighten. The slide has a means for locking the wire actuator in place, for example, using complementary ratchet teeth on the housing and wire actuator mechanism. When the wire actuator button is pressed, the ratchet teeth can disengage and unlock the pull-wire. In some embodiments, the tip can flex from about 0 degrees to about 150 degrees. In another embodiment, the tip can flexed from about 45 degrees to about 100 degrees. The can be designed to be flexible in bending but stiff in torsion, allowing the channel to follow the curvatures of the anatomy and allow for a rotation of the handle from outside the body during use, transmitting torque to rotate the tip to a desired direction.

The working channels positioned inside the outer tube provide a multi-lumen catheter having manipulable passages for independently manipulating tools from outside the body into the working space inside created by expansion of the retractor. In some embodiments, from 1 to 3 flexible tubes run inside of the outer tube and can be detached from the outer tube, as described herein, which facilitates the flexibility of the system. In some embodiments, these flexible tubes can be attached at two points: (i) the proximal coupler

of the retractor, which can be a ring-type structure having ports at the distal end of the outer tube, and (ii) at the proximal end of the shaft, such as at the handle. This can provide a floating arrangement in the outer tube that is unique, constraining the ends of the flexible tubes while allowing for a substantially free-floating movement of the flexible tubes in the outer tube to enhance the flexibility of the system.

In some embodiments, 2 inner tubes can be positioned adjacent to the inner surface of the outer tube to provide, effectively, 3 separate channels. The 2 inner tubes can function as 2 independent working channels while the space between these first 2 working channels and the outer tube functions as a third channel. The third channel can be substantially larger than the other 2 channels. Each of the first 2 working channels can have, for example, an inner diameter ranging from about 2 mm to about 6 mm, about 3 mm to about 5 mm, or any range therein. In some embodiments, the diameter of the first 2 working channels can be about 4 mm. Each of the channels can be designed to accommodate an endoscope such as a colonoscope, as well as tools that include, for example, forceps, graspers, clip applier, dissectors, snares, electrical surgical probes, or loops. In some embodiments, the largest diameter channel can be the channel for the endoscope.

The channel for accommodating the endoscope can be designed to have an inner diameter, for example, ranging from about 5 mm to about 15 mm, from about 6 mm to about 12 mm, from about 11 mm to about 14 mm, from about 5 mm to about 10 mm, from about 8 mm to about 13 mm, or any range therein in 1 mm increments. The inner tubes can comprise any suitable material known to one of skill to be useful for the purposes set-forth herein, as well as composites thereof. For example, the inner tubes can comprises a fluoropolymer such as TEFLON for lubricity to ease tool or endoscope passage and movements. Other materials that may be used include, for example, polyethylene, polypropylene, PEBAX, nylon, polyurethane, silicone, and composites thereof, each of which may also be used with a lubricant coating. The tubes may also comprise a metallic wire reinforcement such as a braid, mesh or helical coil, each of which may be embedded in the tube.

One of skill should appreciate that the systems taught herein can be used as a surgical suite with a floating, multi-lumen-catheter retractor system having a reversibly-stabilized and reversibly-expandable retractor for a minimally invasive treatment of a subject. In these embodiments, the system can comprise a flexible outer tube for guiding a floating channel and a floating endoscope in a substantially floating arrangement within the system. Due to the construction of the floating system, the system is highly flexible, such that the flexible outer tube can be highly flexible and have a lumen, a proximal end, and a distal end; and, the floating channel can serve as a guide through which a tool is manipulated in a treatment of a target tissue in a subject. The retractor can be a reversibly-stabilized and reversibly-expandable retractor forming a treatment space upon expansion. The retractor can be configured, for example, for the expansion to occur distal to the distal end of the outer tube and to reversibly stiffen an otherwise flexible arrangement of the retractor, the flexible arrangement designed to facilitate the positioning of the system in the subject and to reversibly stiffen for the expansion of the retractor.

During a use of the system, the floating channel can be (i) at least slidably-attached to the lumen of the outer tube at a first proximal location and a first distal location and (ii) at least substantially floating in the lumen of the outer tube

between the first proximal location and the first distal location. Likewise, during the use of the system, the floating endoscope can be (iii) at least slidably-attached to the lumen of the outer tube at a second proximal location and a second distal location; and, (iv) at least substantially floating in the lumen of the outer tube between the second proximal location and second distal location. And, during the use of the system, the floating arrangement can (v) at least substantially increase the flexibility of the system over a second such system having lumens for a tool and an endoscope, the lumens affixed to the lumen of the outer tube throughout the length between the proximal end and the distal end of the outer tube. The increased flexibility can facilitate an ease of positioning of the system in the subject; and, the reversibly-stiffened arrangement of the retractor can form an at least substantially rigid beam as a structural support for the expansion in the subject for the treatment of the target tissue.

In some embodiments, the retractor comprises at least two expandable retractor elements, each of the members having a proximal end and a distal end, the proximal end slidably engaged with the outer tube, and each of the members configured such that an increase in the amount of sliding of the proximal end toward the distal end compresses the member and expands the retractor. These embodiments can also include a distal nexus located distal to the distal end of the outer tube and at which the distal end of each of the at least two retractor elements is affixed; and, a stabilizer subsystem connecting the distal nexus to the distal end of the outer tube and having an at least substantially rigid component configured to reversibly stiffen an otherwise flexible portion of the retractor for an asymmetric expansion of the retractor.

In some embodiments, the retractor comprises four expandable retractor elements, each of the members having a proximal end and a distal end, the proximal end slidably engaged with the outer tube, and each of the members configured such that an increase in the amount of sliding of the proximal end toward the distal end compresses the member and expands the retractor. These embodiments can also include a proximal coupler attached to the distal end of the outer tube, the proximal coupler having four retractor ports for the slidable engagement with the four retractor elements, the four retractor ports positioned circumferentially around the proximal coupler and configured to facilitate a reversible, axial sliding of the retractor elements for the asymmetric expansion of the retractor. These embodiments can also include a distal nexus located distal to the distal end of the outer tube and at which the distal ends of each of the four retractor elements are affixed; and, a stabilizer subsystem connecting the distal nexus to the distal end of the outer tube and having (i) a flexible component that extends from the proximal coupler to the distal nexus and (ii) an at least substantially rigid component that is slidably engaged with the proximal coupler and reversibly extends from the proximal coupler to the distal nexus to reversibly-stiffen the retractor in an asymmetric expansion of the retractor.

The flexible component and the rigid component can have central axes that are each at least substantially parallel to the central axis of the distal end of the shaft, the rigid component forming an at least substantially rigid beam as a structural support for the asymmetric expansion, the rigid beam having a luminal side and an abluminal side.

The systems provided herein can be used in several different methods of treatment. For example, the systems can be used in a method of treating a gastrointestinal lesion using a multidirectional and multi-angular approach to the

lesion. The method can include positioning the system in a subject's gastrointestinal tract, the positioning including placing the retractor in proximity to a target lesion for a treatment; expanding the retractor to create the treatment space for use of the tool; treating the lesion with the tool; collapsing the retractor; and, withdrawing the system from the subject. The lesion can include, for example, a perforation, a tissue pathology a polyp, a tumor, a cancerous tissue, a bleed, a diverticuli, an ulcer, an abnormal vessel, or an appendix.

It should be appreciated that there are a number of procedures and variations, in addition to those taught above, that can be used readily by one of skill in the implementation of the systems taught herein. In some embodiments, one of skill can insert the endoscope through the endoscope channel of the system and extend the distal end of the endoscope distal to the distal end of the retractor to form an assembly. The assembly can then be inserted into a body lumen or orifice, such as the colon, and advanced orally until the distal end of the scope or the lens is in proximity to the target tissue (lesion or defect) to be treated. The system is advanced forward over the scope until the retractor is positioned over the distal end of the endoscope while observing the image from the endoscope. The system is advanced until the target tissue is located between the proximal coupler and distal nexus of the retractor while observing the image from the endoscope. The handle or outer tube can be rotated to rotate the retractor so that the target tissue is at the desired position relative to the retractor members while observing the image from the endoscope. The retractor can then be straightened and stabilized by converting the flexible beam to a rigid beam. The retractor can then be expanded by moving the retraction actuator forward on the handle while observing the image from the endoscope. This action pushes the tissue outwards, creates a working space around the target tissue, and anchors and stabilizes the target tissue. Optionally, while the retractor is expanded, the system can be pulled back to shift the peak of the most expanded members distally to improve working distance between the endoscope and the peak of the asymmetric work space, wherein the peak is generally recommended to be located around the target tissue. With the instruments inserted into the working channels, insert the working channels into the proximal ports of the system and advance the instruments and channels distally until the tips of the working channels are distal to proximal coupler of the retractor while observing the image from the endoscope. At this time, the tips of the working channels can be flexed to the appropriate angulation for the tools to approach the lesion to be treated. The working channels can be rotated and moved axially as needed to the desired position for the tools. Likewise, the instruments/tools can be advanced relative to the distal end of the working channels as needed to extend the instruments as needed to reach the target tissue. Various instruments can be inserted through the working channels as desired, and both the endoscope and the instruments can be advanced and positioned independently into the working area to further manipulate and visualize the target tissue at closer proximities or angulations. This is because, in some embodiments, the endoscope can also flex within the working space.

In some embodiments, it's desirable to have a means for delivering a system taught herein with an optional cover, or sheath that covers a portion of the system, including the retractor during delivery of the retractor to a target site, during a treatment of a target tissue at the target site, during a removal of the target tissue, during a removal of the system from the subject, or a combination thereof. Recall that some

embodiments of such an optional cover **355** have been illustrated herein, for example, in FIGS. 3A and 3K. One of skill will appreciate that the retractor has elements that can catch, snag, or otherwise disturb or contact tissue during delivery, or removal, of the retractor to or from the target site. Also, the treatment of the target tissue may include, for example a dissection of tissue that can be performed within the cover without or intermingling the target tissue with the surrounding tissues. Moreover, the dissected tissue may be a cancerous tissue that is desirable to contain during treatment or removal. The terms "cover" and "sheath" can be used interchangeably in many embodiments, and one of skill can appreciate that such embodiments are open to improvements, as taught herein.

FIGS. 10A-10E illustrate a retractor sheath covering a retractor of a system as taught herein, according to some embodiments. FIGS. 10A-10C show top-, oblique-, and side-views a flexible, clear sheath **1000** that covers a collapsed configuration of the retractor **1050** to render an at least substantially smooth and/or atraumatic surface **1005** for a delivery of the retractor **1050** to a target site (not shown) for a treatment of a target tissue (not shown). In FIGS. 10A-10C, the cover is in a closed configuration that can be sustained until the expansion of the retractor **1050** for the treatment, or it can be reversibly-obtained following the treatment. FIGS. 10D and 10E show a top-view and side-view of an expanded configuration of the retractor with the cover in an open configuration for the treatment.

The sheath **1000** can be designed to prevent or inhibit the retractor elements **1051,1052,1053,1054** and bridges **1044a, 1044b** from catching, snagging, or otherwise disturbing or contacting tissue during a delivery or removal of the retractor **1050** to or from the target site. Note also, optional bridge retainer **1044c** used in operable connection with upper bridge **1044a**, for example. Such retainers can be used at any position around the retractor to facilitate a retention of the configuration of the working space **1060**, for example, to retain the configuration under forces of the expansion of the retractor **1050**. During the procedure the sheath **1050** can also prevent or inhibit tissue from entering the retractor **1050** until desired. The sheath **1050** can also act as a collection means for entrapping and/or pulling out a resected tissue, which can be particularly desirable in the resection of cancerous tissue in some embodiments. The sheath **1000** can be at least substantially closed around the retractor **1050** during delivery, and can be designed to open as the retractor **1050** is expanded to create the working space **1060** for the treatment. As described herein, flexible beam **1070** can be converted to the at least substantially rigid beam **1075** using a means for the conversion as taught herein, for the expansion.

In some embodiments, the sheath **1000** can be perforated longitudinally (not shown), designed such that the sheath **1000** opens upon expansion of the retractor **1050** through tearing of the perforation at the target site. In some embodiments, a tongue-and-groove mechanism, for example a ZIPLOCK mechanism, can be used to at least substantially close a slit **1007** at the top of the retractor **1050** which can also open upon the expansion of the retractor **1050** at the target site. In some embodiments, a larger perforation, or unclosed portion **1001**, can remain in the sheath **1000** to facilitate the tearing or opening of the sheath at the target site upon the expansion of the retractor **1050**. In some embodiments, the terms "slit" and "opening" can be used interchangeably.

In some embodiments, the sheath can be reversibly opened, such that the sheath can be re-closable. For

example, a drawstring, cable, or wire, can be operably positioned in communication with the opening for the reclosing of the opening by pulling or pushing the drawstring, cable, or wire from outside the patient during the treatment. In some embodiments, the edges of the opening can form longitudinal pockets or channels for pulling or pushing the drawstring, cable, or wire as desired from outside the patient during the treatment, such as by routing the drawstring, cable, or wire through the system and, perhaps, through the handle as with the other actuation means. In some embodiments, a drawstring is used to re-close the sheath, wherein the strings can be tensioned at the handle to close the slit, or loosened to allow the retractor to expand. In some embodiments, the sheath has a stiffening strip running transversely around the midportion of the cage to facilitate the cage wires expanding without catching on the surrounding sheath. The stiffening strip can be another layer of the sheath welded or glued onto the existing sheath. It can also be formed as a thickened area. Alternatively, a stiffer material can be inserted in the pocket running transversely. The stiffening material may be the same as that of the sheath or it may be a stiffer material.

One of skill will appreciate that any of the known materials and/or methods of covering the sheath may be useful for the purposes taught herein. For example, the sheath can range from about 10 mm to about 30 mm at the ends that are attached to the proximal coupler and distal nexus, each of which can be used to define the ends of the retractor **1050**. Moreover, the sheath can be heat welded, glued, or heat-shrunk to the proximal coupler and/or distal nexus, or perhaps substantially proximal or distal to these components, to fasten the sheath to the retractor. In some embodiments, the sheath may even cover the system as a sterilizing, or clean, cover, such that the sheath is an extension of a disposable and/or replaceable component that may be applied, for example, in a sterilization process. And, in some embodiments, the sheath can be larger at the mid portion where the diameter can range, for example, from about 20 mm to about 40 mm in a closed configuration. The sheath can be, for example, opaque, translucent, or clear, and the material composing the sheath can be, for example, a polyethylene, nylon, fluorinated ethylene propylene (FEP), TEFLON, polyethylene terephthalate (PET), or polycarbonate. And, in some embodiments, the sheath material can range, for example, from about 0.0010" to about 0.0060" thick, from about 0.0020 to about 0.0080" thick, from about 0.0030" to about 0.0050" thick, from about 0.0010" to about 0.0030" thick, from about 0.0005" to about 0.0100" thick, about 0.0020" thick, or any range therein in about 0.0005" increments.

Without intending to be limited to any theory or mechanism of action, the above teachings were provided to illustrate a sampling of all possible embodiments rather than a listing of the only possible embodiments. As such, it should be appreciated that there are several variations contemplated within the skill in the art that will also fall into the scope of the claims.

We claim:

1. An endoluminal system for removing a lesion from a body lumen of a patient comprising:
  - an endoscopic device having a longitudinal axis, a flexible outer tube, and a chamber movable with respect to the longitudinal axis, the chamber formed by a plurality of flexible elements, the chamber movable from an insertion position to an expanded position using an actuator disposed on a handle of the endoscopic device, the actuator operably connected to a proximal end of at



least one of the plurality of flexible elements to apply a force to a wall of the body lumen to move the wall radially to increase a working space for access to the lesion;

a first instrument insertable through a first lumen in the flexible outer tube of the endoscopic device, the first instrument having a first tip, the first tip manipulable at a bent angle from the longitudinal axis of the endoscopic device within the chamber to extend radially toward the lesion; and

a second instrument insertable through a second lumen in the flexible outer tube of the endoscopic device and having a second tip, the second tip manipulable at a bent angle from the longitudinal axis of the endoscopic device within the chamber to extend radially toward the lesion;

wherein the chamber includes an access opening for access to the interior of the chamber;

wherein the plurality of flexible elements are connected at a distal portion to a distal nexus, and

wherein the endoscopic device includes an opening at a proximal coupler through which the first and second instruments are extendable, and the flexible elements are positioned distal of the opening.

[2. The system of claim 1, wherein the chamber includes a cover to form an enclosed chamber to capture a lesion therein for withdrawal from the body lumen, the cover having an access opening for access to an interior of the chamber.]

[3. The system of claim 1, wherein the chamber is formed by a plurality of flexible elements, the flexible elements connected at a distal portion.]

[4. The system of claim 3, wherein the endoscopic device includes an opening at a distal portion through which the first and second instruments are extendable, and the flexible elements are positioned distal of the opening.]

5. The system of claim [3] 1, wherein the flexible elements expand at an intermediate portion to form an arcuate portion.

6. The system of claim 1, further comprising a longitudinally extending rigid portion extending in the chamber.

7. The system of claim 1, wherein the chamber is expandable asymmetrically to create an asymmetric chamber so a distance configured to extend from the longitudinal axis of the endoscopic device to a wall of the body lumen having the lesion is greater than a distance configured to extend from the longitudinal axis of the endoscopic device to a wall of the body lumen opposite the lesion.

8. An endoluminal system for removing a lesion from a body lumen of a patient comprising:

an endoscopic device having a longitudinal axis and a chamber movable with respect to the longitudinal axis, the chamber movable from an insertion position to an expanded position [to apply a force to a wall of the body lumen] to move the wall radially to increase a working space for access to the lesion,

the endoscopic device comprising a flexible outer tube and first and second lumens for receiving first and second instruments therethrough,

the endoscopic device having an opening in a distal portion through which the first and second instruments can extend for positioning and bending within the chamber, and the chamber is formed by a plurality of flexible elements, the flexible elements positioned distal of [an] the opening in the endoscopic device through which the first and second instruments extend;

wherein the chamber includes a substantially rigid beam movable longitudinally in a direction toward the chamber to rigidify one of the flexible elements forming the chamber.

9. The system of claim 8, [further comprising a longitudinally extending rigid portion extending] wherein the substantially rigid beam is extendable within the chamber.

10. The system of claim 8, wherein the chamber is expandable asymmetrically to create an asymmetric chamber so a distance configured to extend from the longitudinal axis of the endoscopic device to a wall of the body lumen having the lesion is greater than a distance configured to extend from the longitudinal axis of the endoscopic device to a wall of the body lumen opposite the lesion.

[11. The system of claim 8, further comprising a first tool channel and a second tool channel extending through the device, the first tool channel dimensioned to receive the first instrument and the second tool channel dimensioned to receive the second instrument, the first and second tool channels bendable to bend the tips of the first and second instruments inserted therethrough.]

[12. The system of claim 8, wherein the chamber includes a substantially rigid beam movable longitudinally in a direction toward the chamber to rigidify one of the flexible elements forming the chamber.]

13. The system of claim 8, wherein the flexible elements are connected at a proximal portion and a distal portion and [expanded] expand at a region between the proximal and distal portions.

14. The system of claim 8, wherein the endoscopic device is dimensioned to removably receive an endoscope.

[15. An endoluminal system for removing a lesion from a body lumen of a patient comprising an endoscopic device having a longitudinal axis and a chamber movable with respect to the longitudinal axis, the chamber movable from an insertion position to an expanded position to apply a force to a wall of the body lumen to move the wall radially to increase a working space for access to the lesion, the endoscopic device having an opening in a distal portion through which first and second instruments can extend for positioning and bending within the chamber, wherein the chamber has a cover positioned at least partially thereover to create an entrapment for capture of the lesion and containment of the lesion for withdrawal from the body lumen.]

[16. The system of claim 15, wherein the chamber is formed of a plurality of flexible elements and the cover is spread by expansion of the plurality of flexible elements.]

[17. The system of claim 15, wherein the chamber is formed of a plurality of flexible elements and the cover has an access opening for access to an interior of the chamber through which the first and second instruments can extend.]

[18. The system of claim 15, wherein the cover is positioned at least partially over the flexible elements and the cover is opened by the plurality of flexible elements.]

19. The system of claim 1, wherein the actuator is multi-positional, having a plurality of positions for expansion of the chamber.

20. The system of claim 19, wherein the actuator has at least three positions for expansion of the chamber.

21. The system of claim 1, wherein the actuator has a plurality of ratchet teeth to provide a plurality of positions for reversibly fixing the chamber in position during expansion or collapse of the chamber.