

US00RE48790E

(19) **United States**  
(12) **Reissued Patent**  
**Kawagoe et al.**

(10) **Patent Number:** **US RE48,790 E**  
(45) **Date of Reissued Patent:** **Oct. 26, 2021**

(54) **ILLUMINATING APPARATUS**  
(71) Applicant: **PANASONIC CORPORATION**,  
Osaka (JP)  
(72) Inventors: **Shinya Kawagoe**, Osaka (JP); **Naotaka Hashimoto**, Osaka (JP); **Toshiyasu Kojima**, Osaka (JP); **Taku Ikeda**, Osaka (JP); **Akira Taniuchi**, Osaka (JP)  
(73) Assignee: **PANASONIC CORPORATION**,  
Osaka (JP)

(52) **U.S. Cl.**  
CPC ..... **F21V 5/04** (2013.01); **F21K 9/233** (2016.08); **F21K 9/69** (2016.08); **F21V 7/09** (2013.01);  
(Continued)  
(58) **Field of Classification Search**  
CPC ... **F21K 9/233**; **F21K 9/68**; **F21V 7/04**; **F21V 11/14**; **F21V 29/004**; **F21V 29/505**; **F21V 29/83**; **H01L 33/60**  
See application file for complete search history.

(21) Appl. No.: **16/248,199**  
(22) Filed: **Jan. 15, 2019**

(56) **References Cited**  
**U.S. PATENT DOCUMENTS**  
4,021,659 A 5/1977 Wiley  
4,821,161 A 4/1989 Koontz  
(Continued)

**Related U.S. Patent Documents**

Reissue of:  
(64) Patent No.: **8,858,039**  
Issued: **Oct. 14, 2014**  
Appl. No.: **13/132,895**  
PCT Filed: **Dec. 9, 2009**  
PCT No.: **PCT/JP2009/006727**  
§ 371 (c)(1),  
(2) Date: **Jun. 3, 2011**  
PCT Pub. No.: **WO2010/084546**  
PCT Pub. Date: **Jul. 29, 2010**

**FOREIGN PATENT DOCUMENTS**

CN 2781168 5/2006  
CN 2781168 Y 5/2006  
(Continued)

U.S. Applications:  
(63) Continuation of application No. 15/292,875, filed on Oct. 13, 2016, now Pat. No. Re. 47,293, which is an application for the reissue of Pat. No. 8,858,039.

**OTHER PUBLICATIONS**

Japanese Application No. 2010-547317 Office Action dated Jun. 18, 2013, 3 pages.  
(Continued)

(30) **Foreign Application Priority Data**  
Jan. 20, 2009 (JP) ..... 2009-010178  
Feb. 27, 2009 (JP) ..... 2009-045543

*Primary Examiner* — James A Menefee  
(74) *Attorney, Agent, or Firm* — Greenblum & Bernstein, P.L.C.

(51) **Int. Cl.**  
**F21V 29/00** (2015.01)  
**F21V 5/04** (2006.01)  
(Continued)

(57) **ABSTRACT**  
Provided is a lighting apparatus that is suitable as a substitute for a conventional halogen lamp when positively utilizing leaked light. The lighting apparatus comprises: a heat dissipator **12** that is in one of a bottomed cylindrical shape and a bowl shape, and that has a bottom portion, a circumferential wall portion, and an opening; and a light-emitting device **18b** that is provided inside the heat dissipator **12** at the bottom portion and is operable to emit light, wherein the  
(Continued)

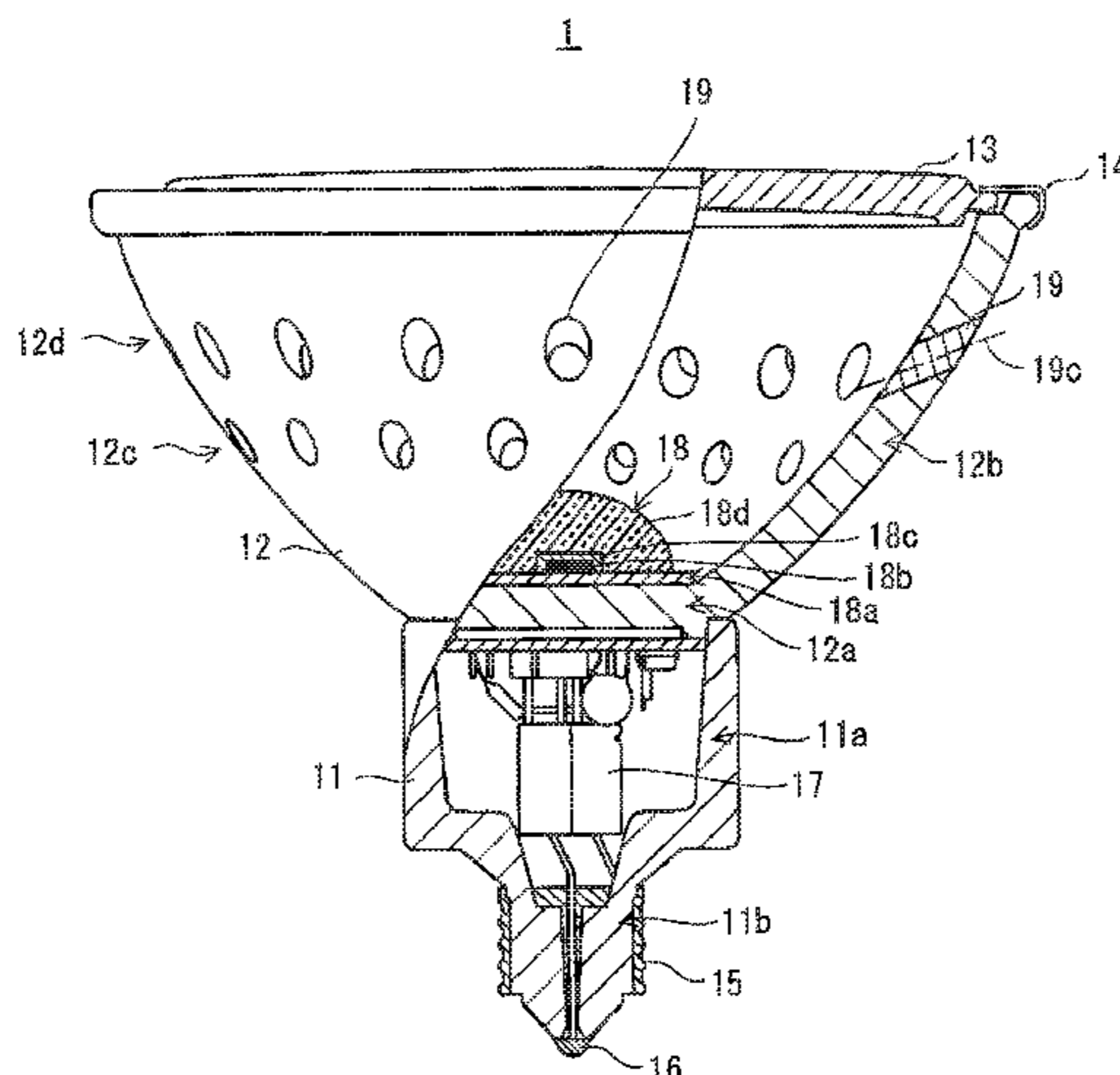

heat dissipator 12 has one or more windows 19 for leaking the emitted light outside the heat dissipater 12.

9 Claims, 20 Drawing Sheets

(51) Int. Cl.

*F21V 29/505* (2015.01)  
*F21V 29/74* (2015.01)  
*F21V 29/80* (2015.01)  
*F21V 29/83* (2015.01)  
*F21V 29/85* (2015.01)  
*F21K 9/233* (2016.01)  
*F21K 9/69* (2016.01)  
*F21V 7/09* (2006.01)  
*F21V 11/14* (2006.01)  
*H01L 33/60* (2010.01)  
*F21Y 115/10* (2016.01)

(52) U.S. Cl.

CPC ..... *F21V 11/14* (2013.01); *F21V 29/505* (2015.01); *F21V 29/74* (2015.01); *F21V 29/80* (2015.01); *F21V 29/83* (2015.01); *F21V 29/86* (2015.01); *H01L 33/60* (2013.01); *F21Y 2115/10* (2016.08); *H01L 2924/0002* (2013.01)

(56) References Cited

U.S. PATENT DOCUMENTS

5,287,259 A 2/1994 Lautzenheiser  
 6,979,107 B1 12/2005 Benensohn  
 7,985,005 B2 7/2011 Alexander et al.  
 RE47,293 E \* 3/2019 Kawagoe ..... F21K 9/69  
 2004/0057234 A1 \* 3/2004 Mohacsi ..... 362/231  
 2004/0264197 A1 12/2004 Bewig et al.  
 2005/0073849 A1 4/2005 Rhoads et al.  
 2005/0111234 A1 5/2005 Martin et al.  
 2005/0201106 A1 9/2005 Hartmann  
 2005/0281047 A1 12/2005 Coughaine et al.  
 2006/0274529 A1 12/2006 Cao  
 2007/0019413 A1 1/2007 Moore et al.  
 2007/0195527 A1 8/2007 Russell  
 2007/0268706 A1 11/2007 Wagener et al.  
 2008/0130288 A1 6/2008 Catalano  
 2009/0003009 A1 1/2009 Tessnow et al.  
 2009/0021945 A1 1/2009 Holder et al.  
 2009/0213595 A1 \* 8/2009 Alexander et al. .... 362/373  
 2010/0002444 A1 1/2010 Konaka  
 2010/0033971 A1 2/2010 Lu  
 2010/0118541 A1 5/2010 Li

FOREIGN PATENT DOCUMENTS

CN 101078495 11/2007  
 CN 201028339 2/2008  
 CN 201028339 Y 2/2008  
 CN 101191588 6/2008  
 CN 10134427 1/2009  
 CN 101344227 1/2009  
 DE 102004024599 12/2005  
 EP 0136684 4/1985  
 EP 1003202 5/2000  
 GB 1504689 3/1978  
 JP 58-144317 9/1983  
 JP S58-144317 9/1983  
 JP 64-084506 3/1989  
 JP H1-86007 6/1989  
 JP H1-86007 U 6/1989  
 JP 2-121749 U 10/1990  
 JP 1990-121749 10/1990  
 JP 8-185834 7/1996  
 JP 10-069808 3/1998  
 JP 2001-307535 11/2001  
 JP 2006-202612 8/2006  
 JP 2007-317431 12/2007  
 JP 3144139 8/2008  
 JP 3144139 U 8/2008  
 JP 3147051 11/2008  
 JP 3147051 U 12/2008  
 JP 3162155 7/2010  
 JP 3162155 U 7/2010  
 WO 2008/035694 3/2008  
 WO WO 2008/035694 3/2008

OTHER PUBLICATIONS

International Search Report in PCT/JP2009/006727, dated Mar. 9, 2010.  
 EPO Communication Pursuant to Article 94(3) EPC, dated Jul. 22, 2016.  
 Chinese Patent Application No. 200980154478.7 Office Action dated Mar. 20, 2013, 11 pages.  
 Japanese Application No. 2011-021703 Office Action dated Nov. 1, 2011, 2 pages.  
 Japanese Application No. 2011-021703 Office Action dated Jan. 10, 2012, 5 pages.  
 Japanese Patent Application No. 2010-547317 Office Action dated Jun. 18, 2013, 3 pages.  
 U.S. Appl. No. 13/762,243 Office Action dated Nov. 13, 2013.  
 Chinese Patent Application No. 200980154478.7 Office Action dated Sep. 22, 2013; 22 pages including partial English translation.  
 European Application No. 09838740.0 Extended European Search Report dated Mar. 24, 2014, 11 pages.

\* cited by examiner

FIG. 1

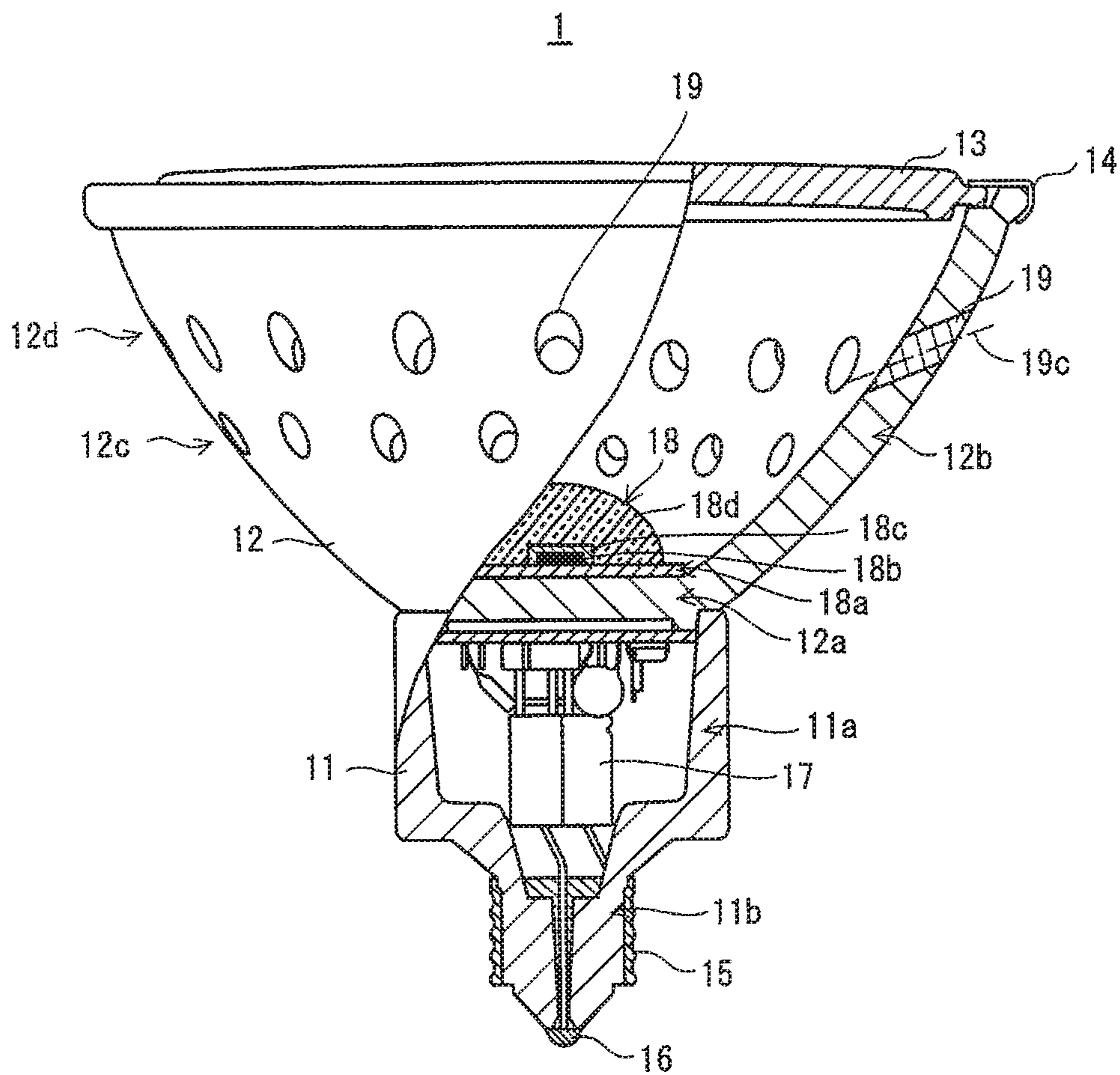

FIG. 2

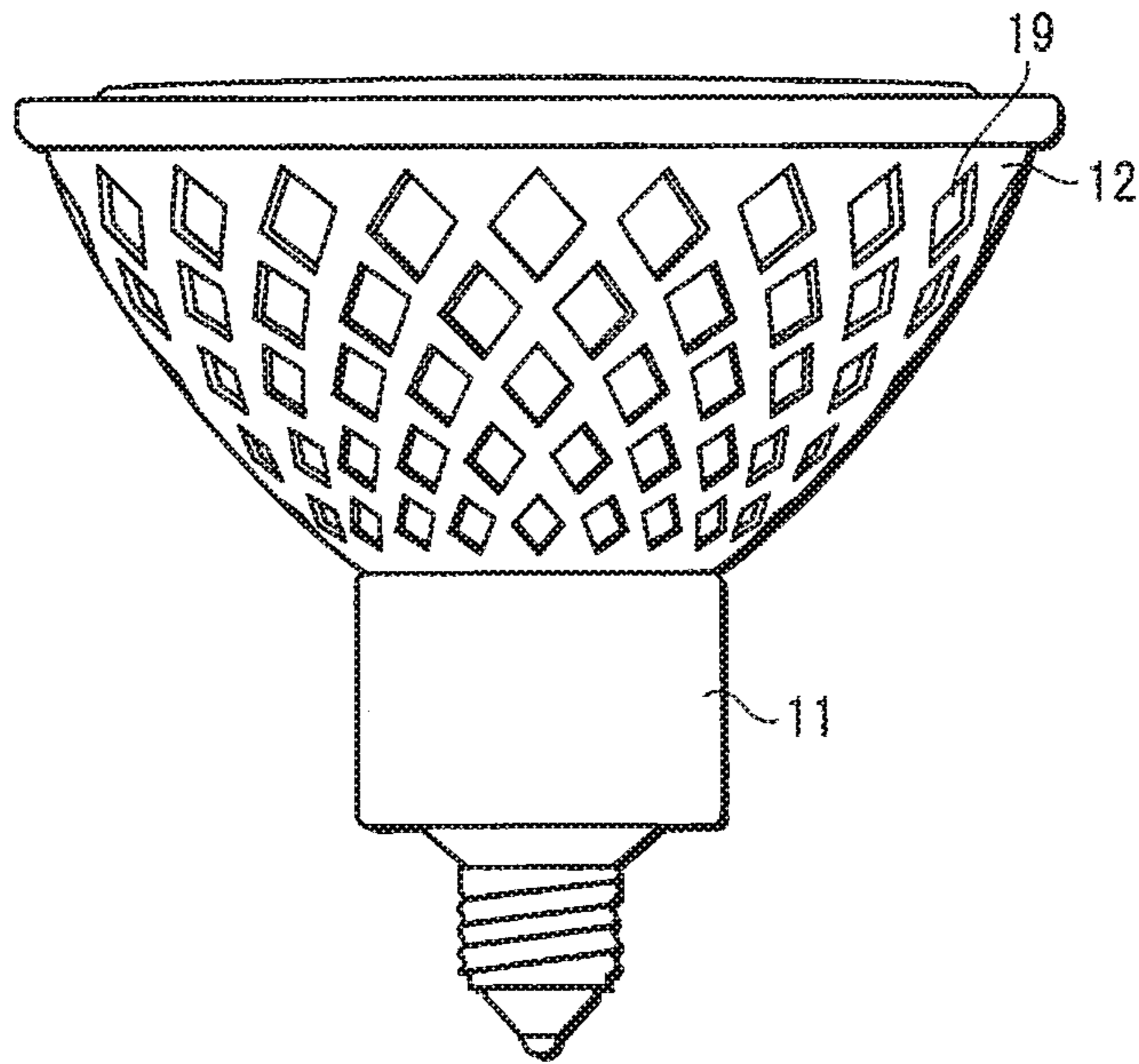

FIG. 3

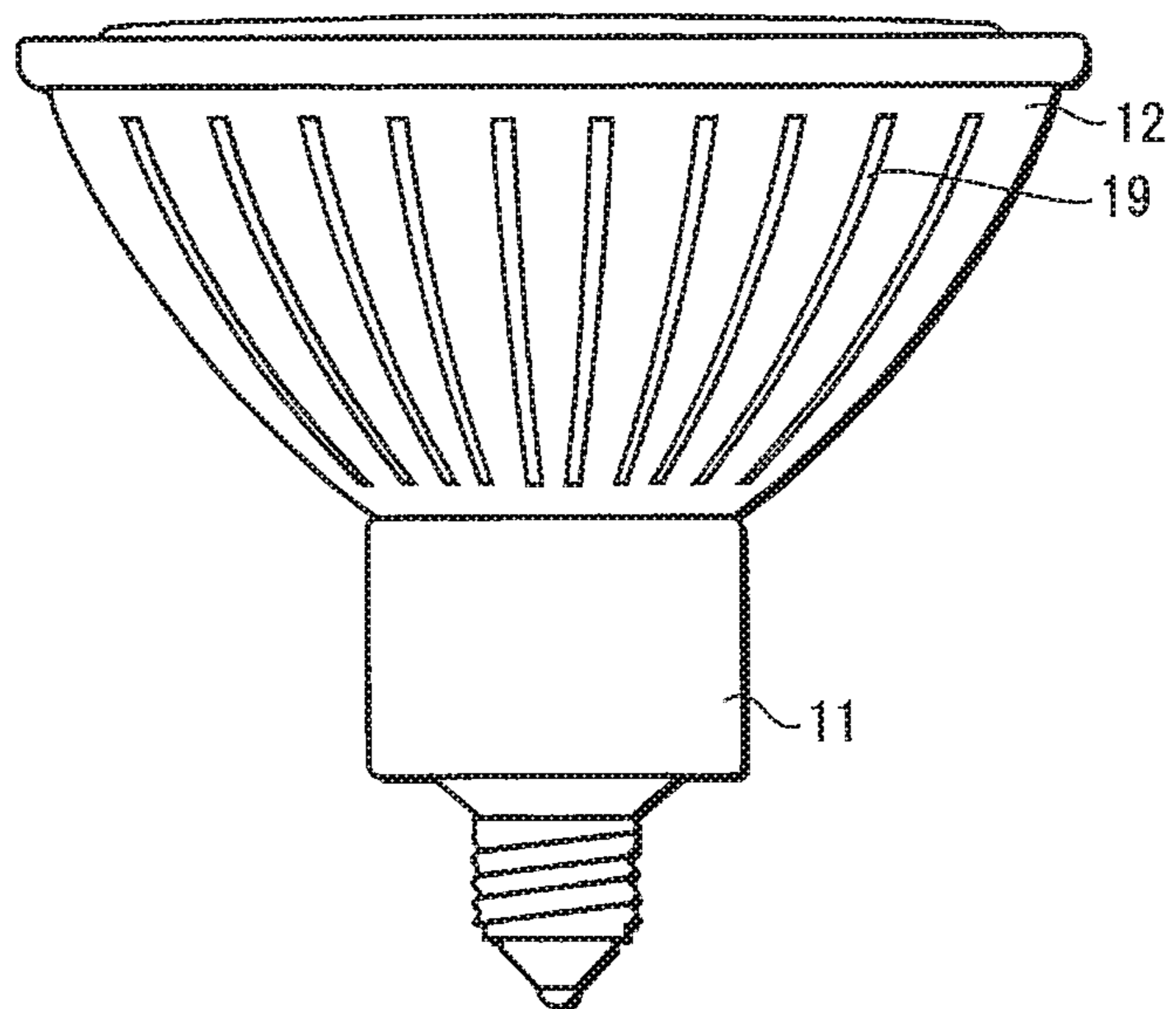

FIG. 4

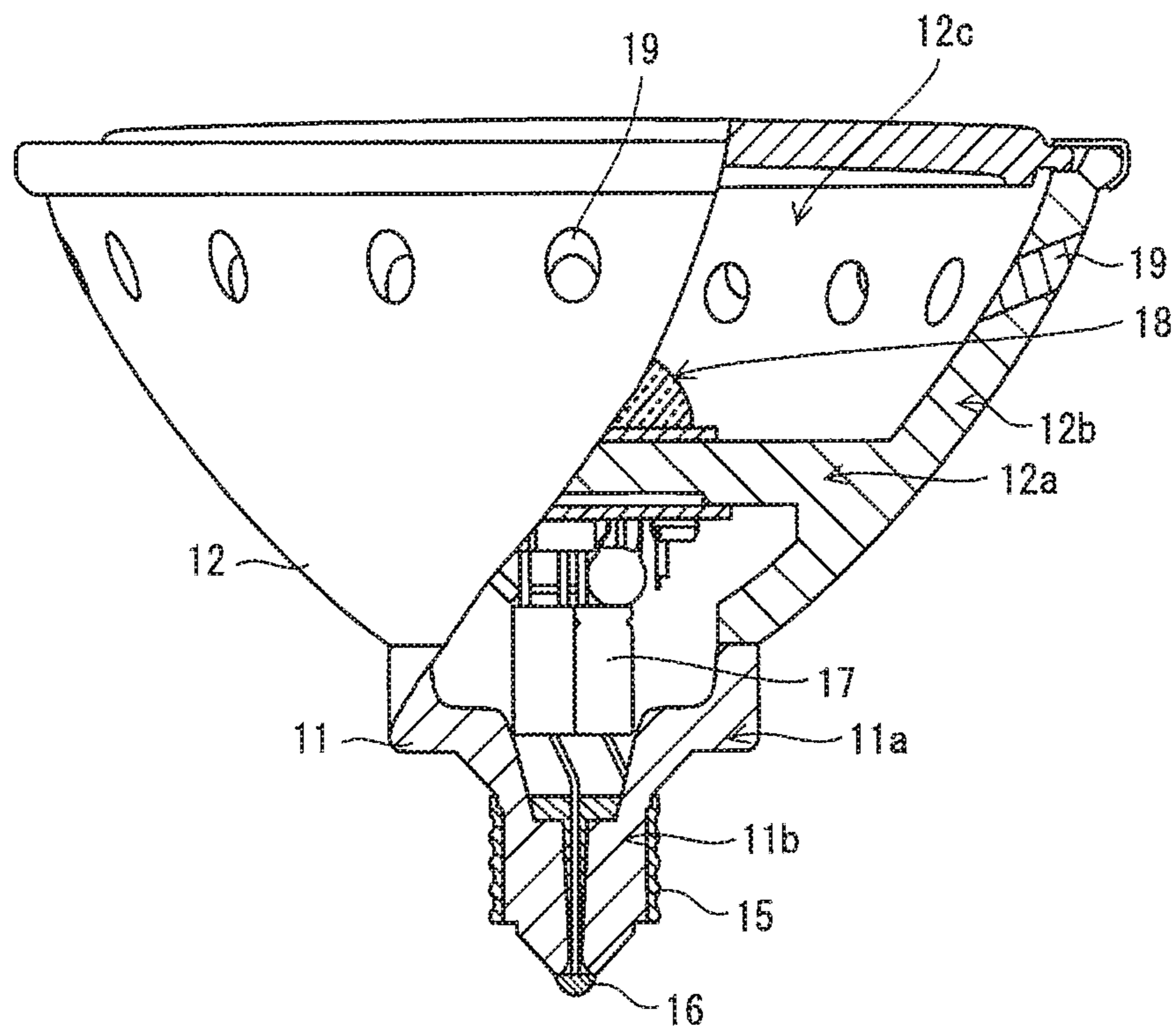

FIG. 5A

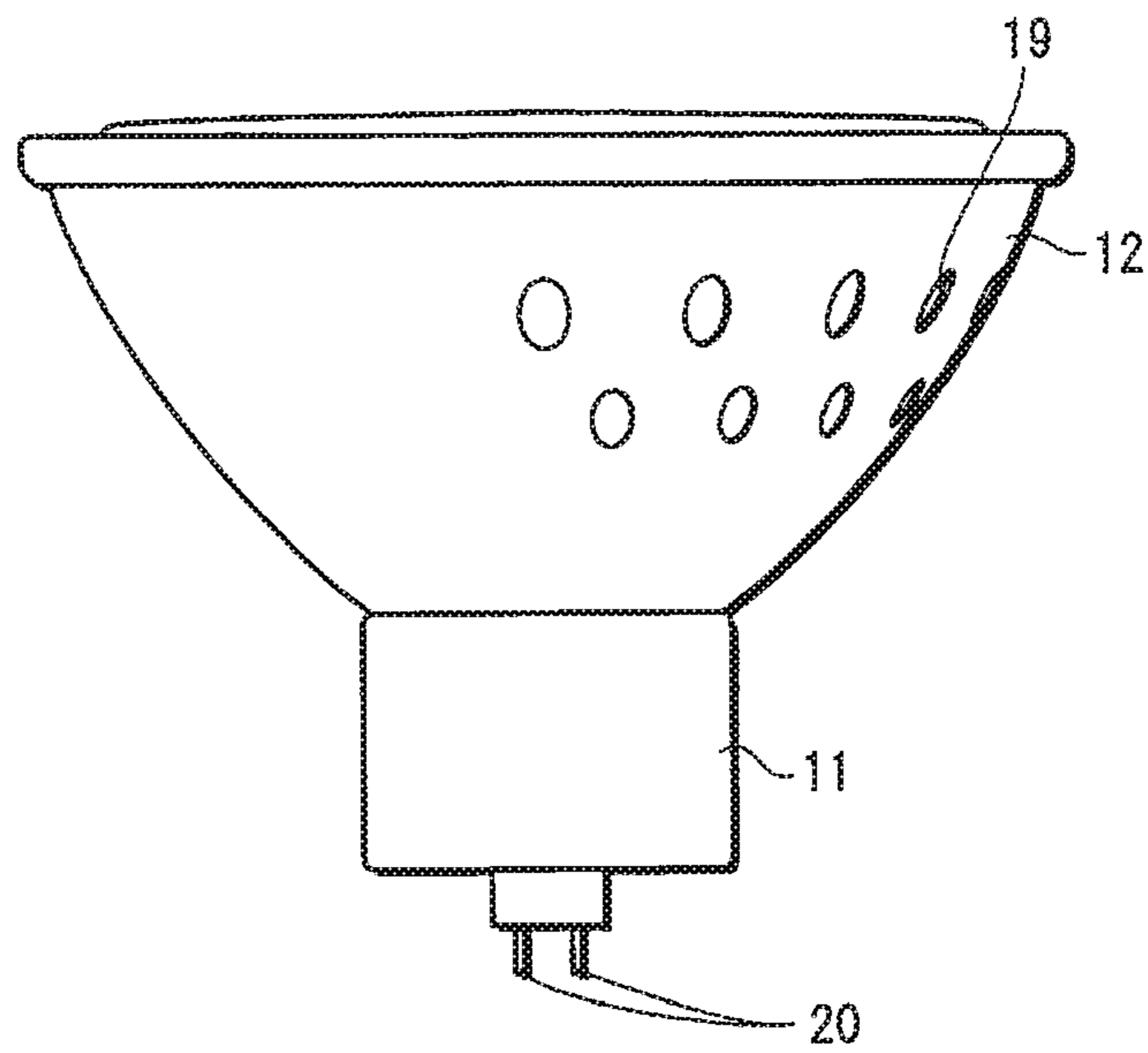

FIG. 5B

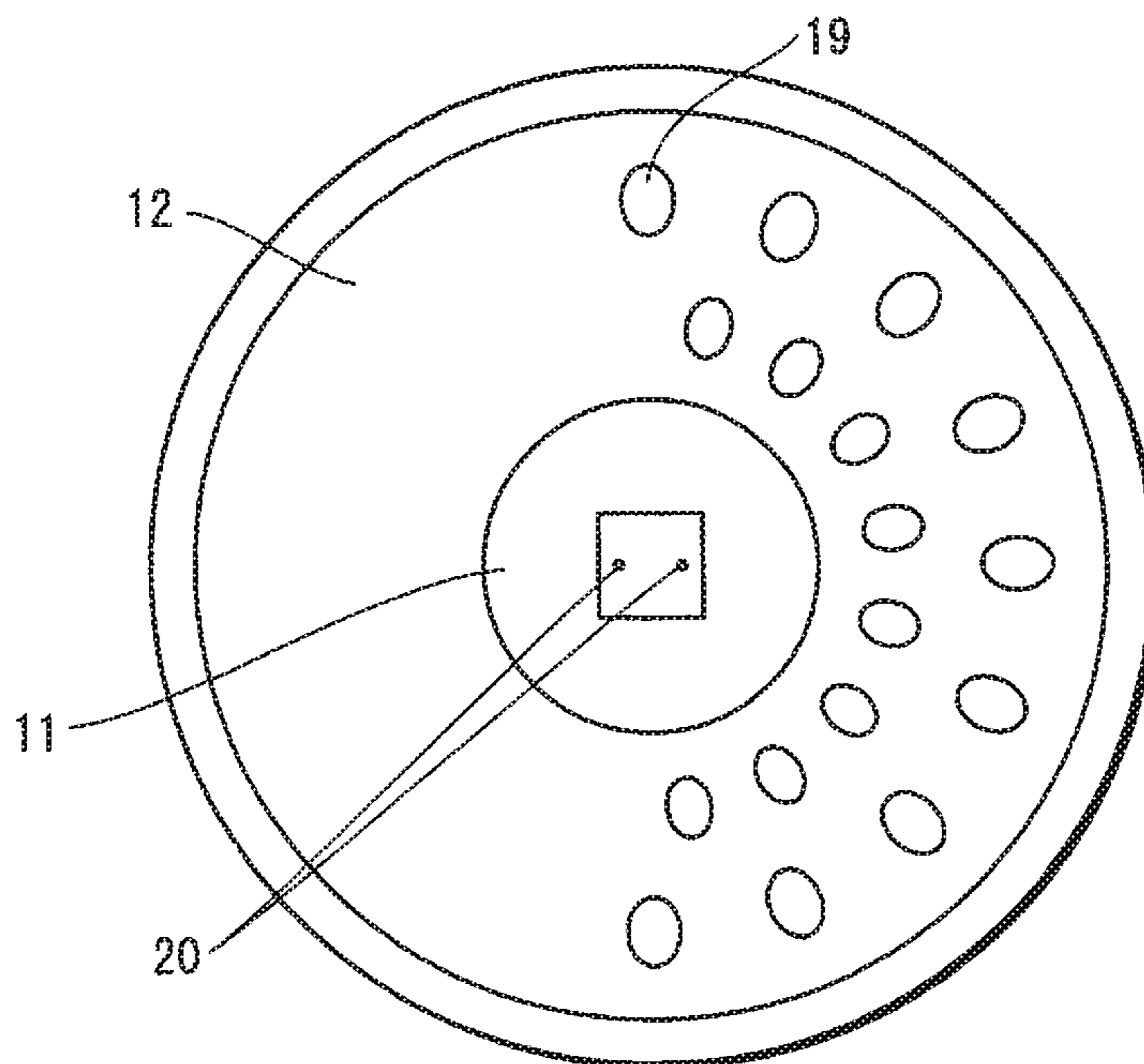

FIG. 6A

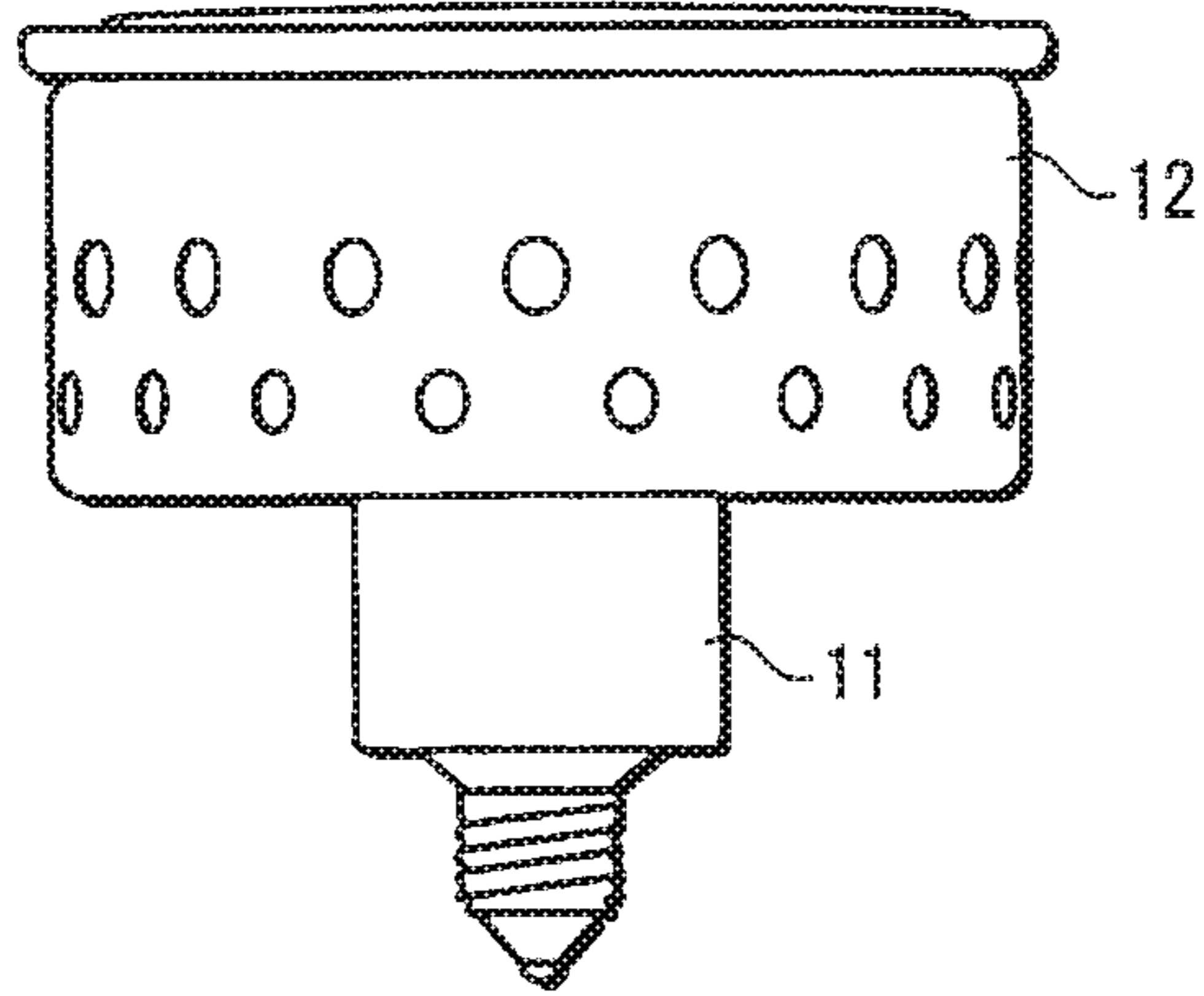

FIG. 6B

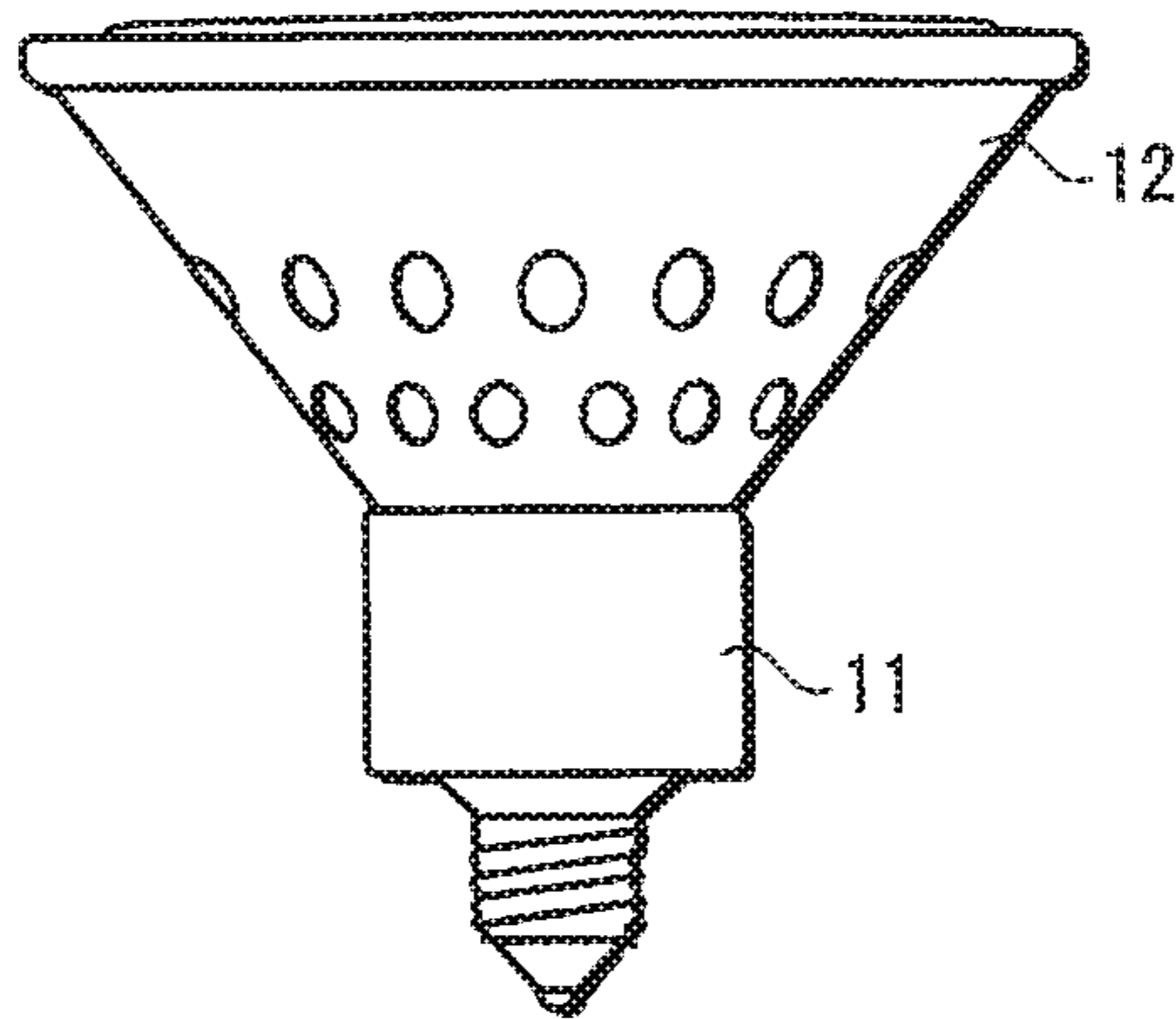

FIG. 6C

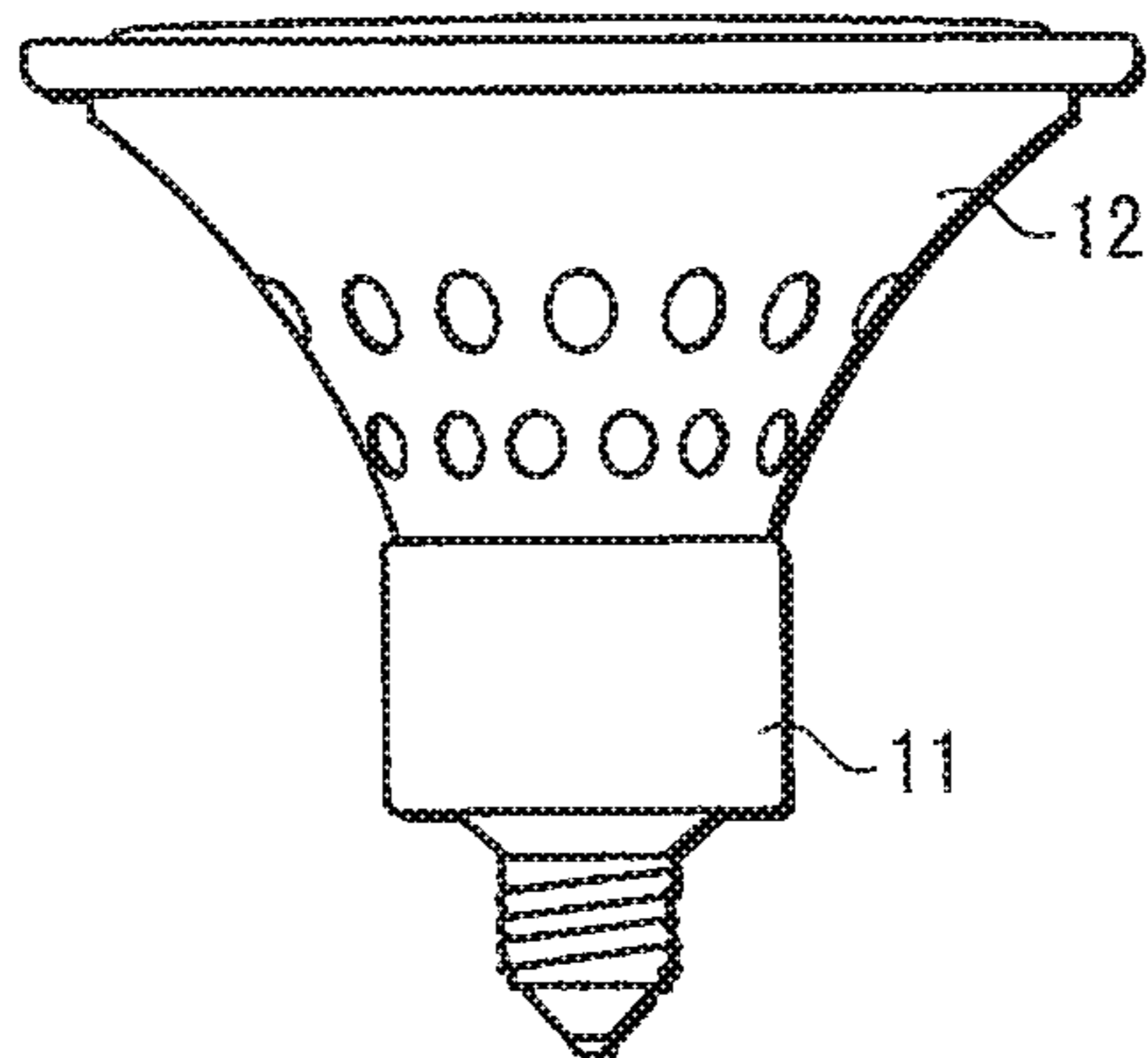

FIG. 7

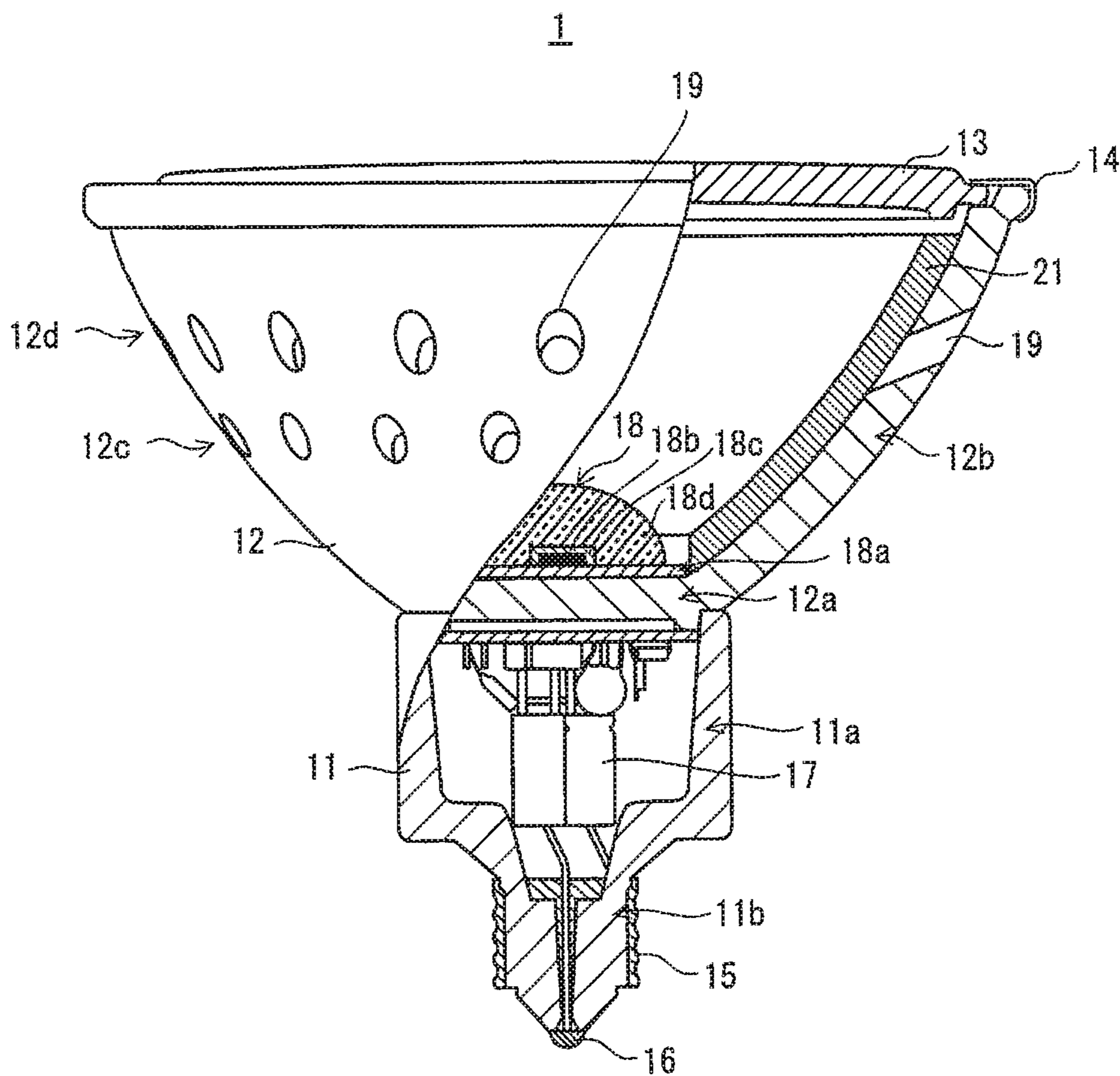



FIG. 8A

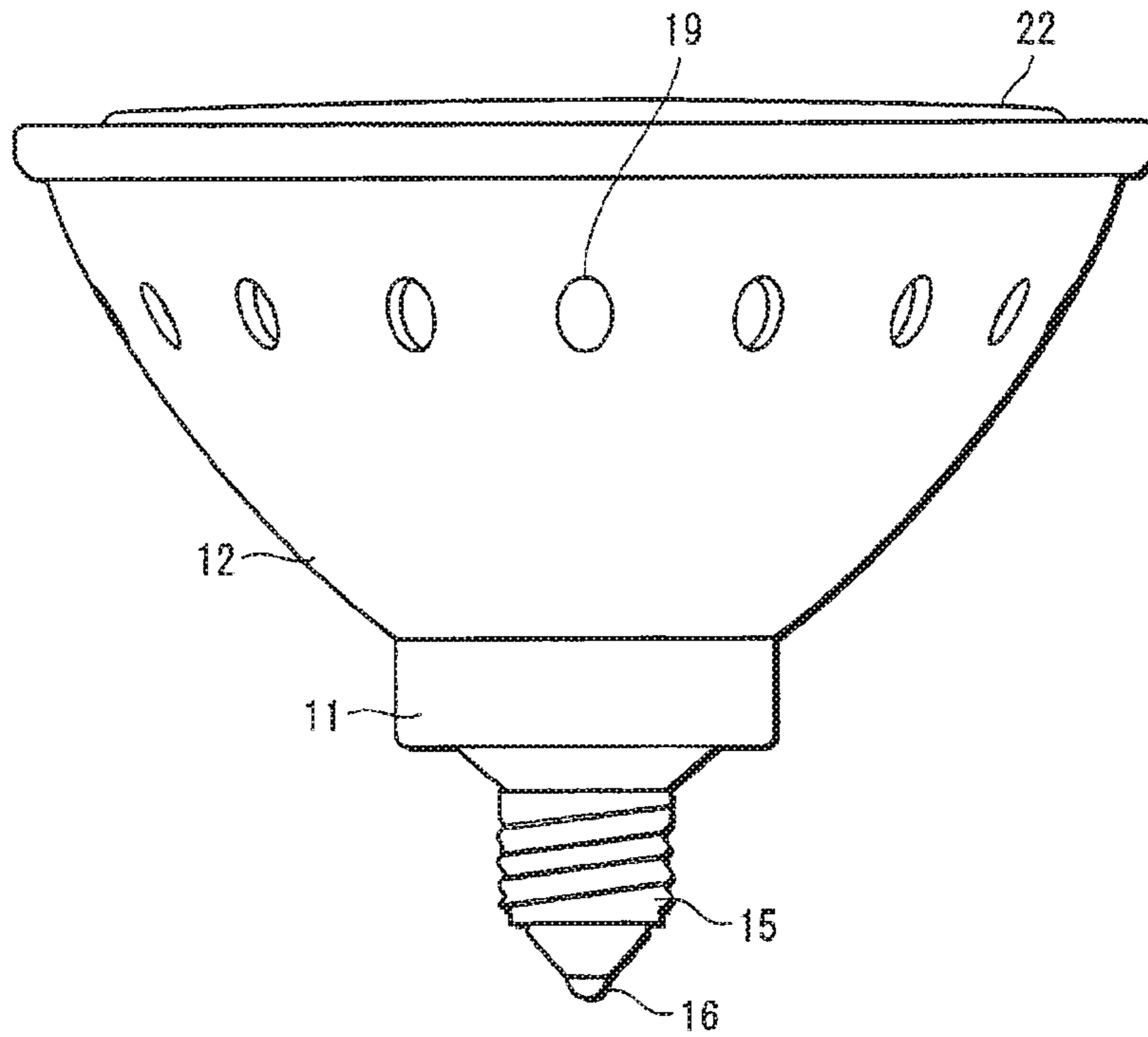

FIG. 8B

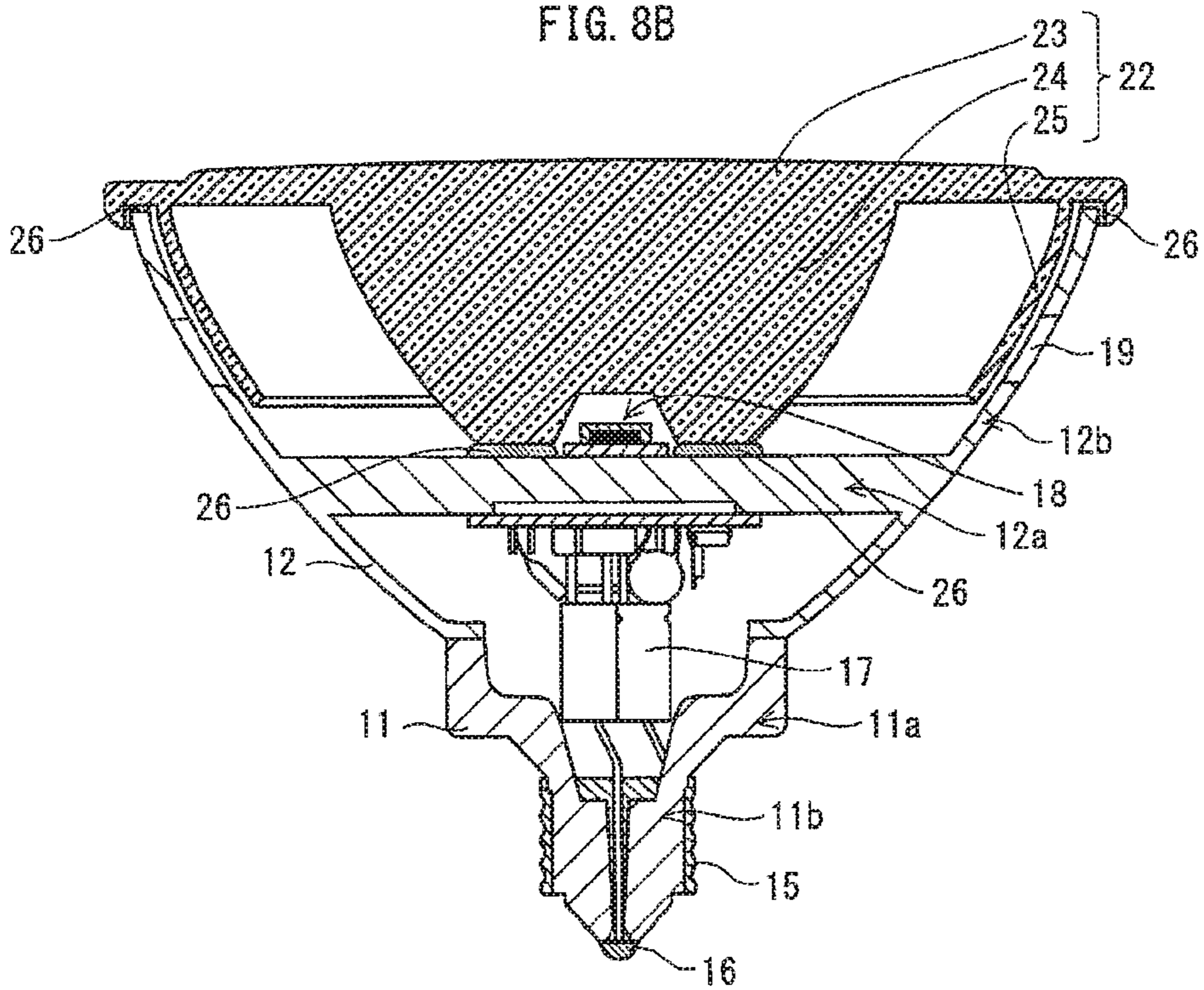

FIG. 9A

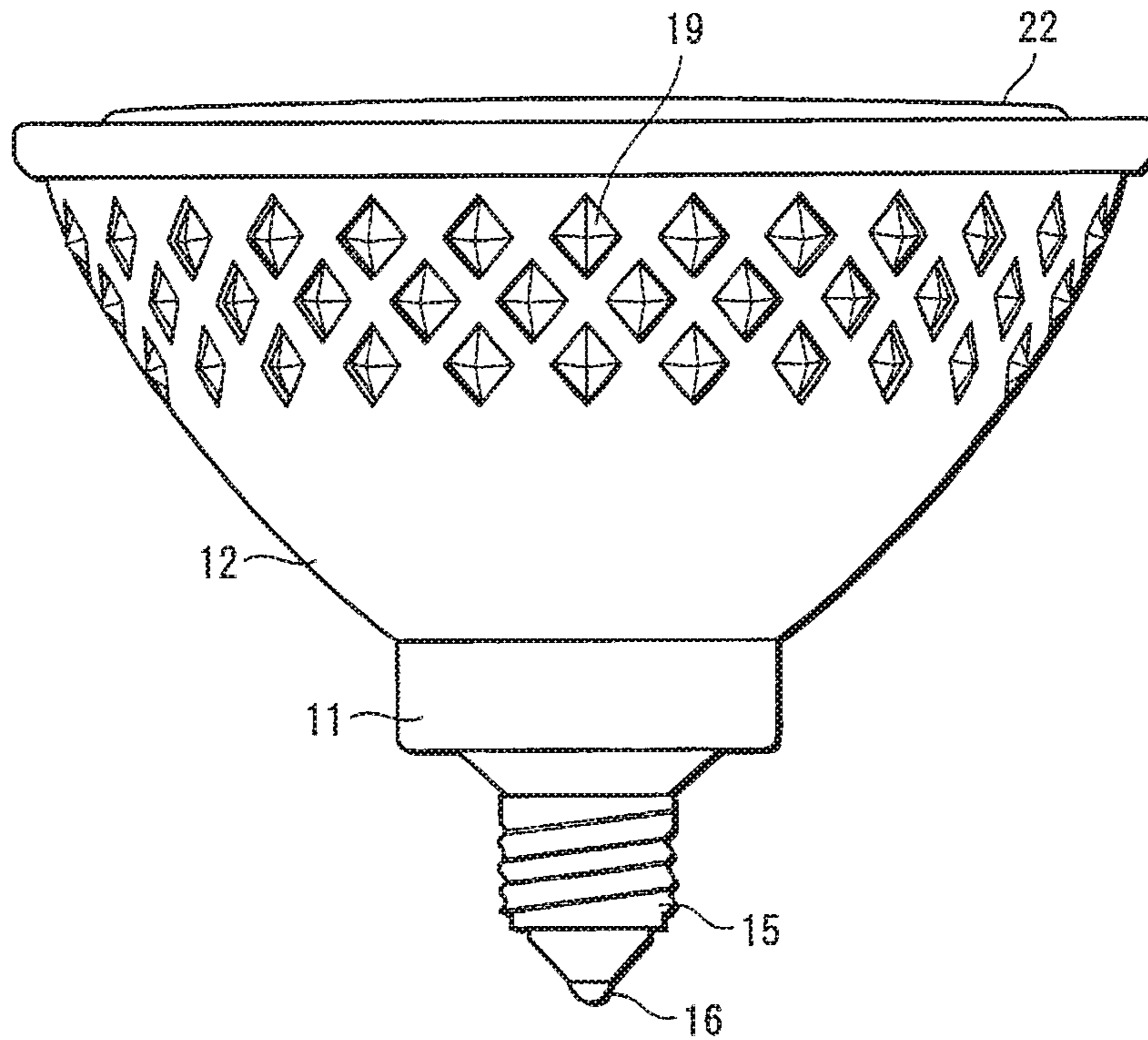

FIG. 9B

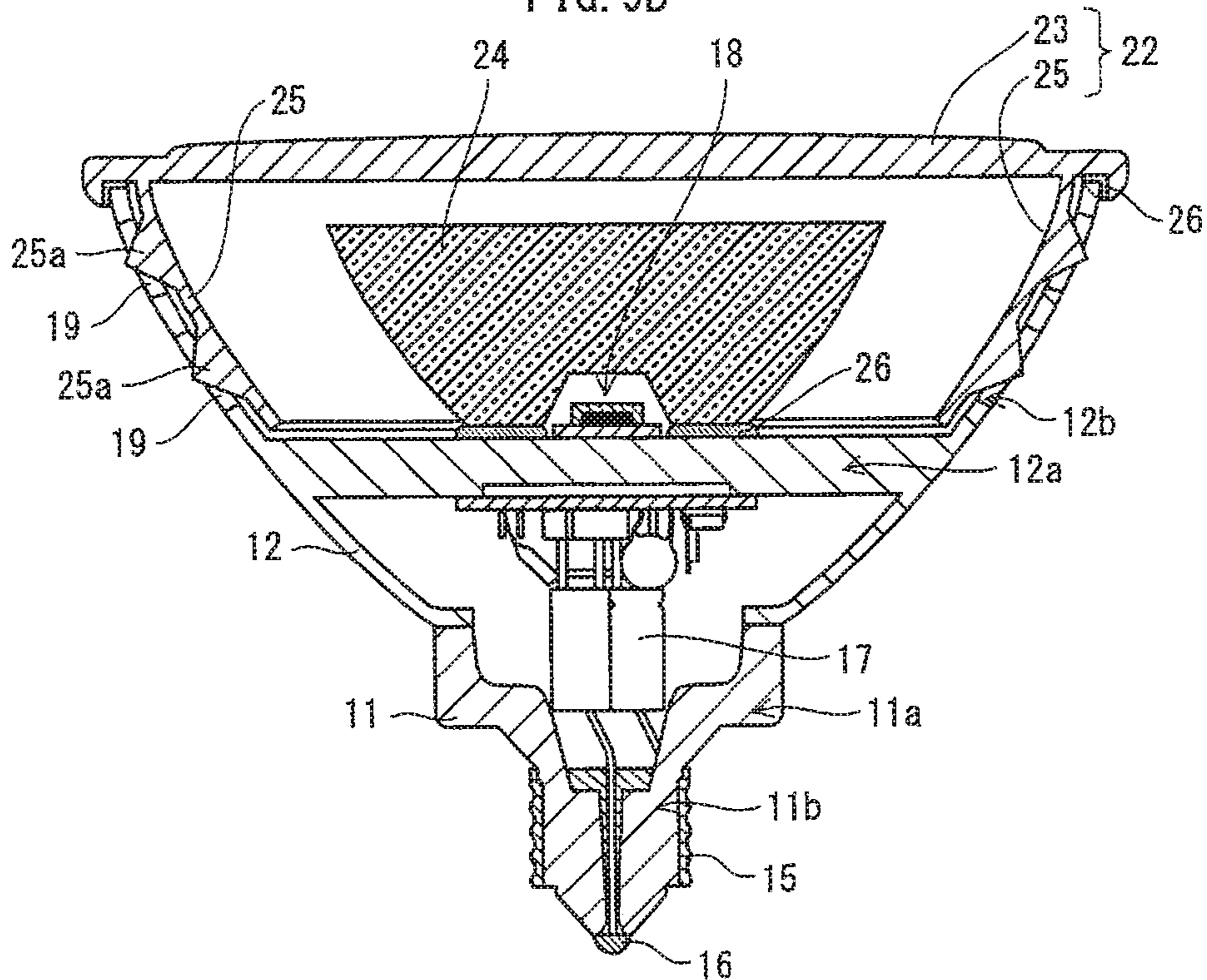

FIG. 10A

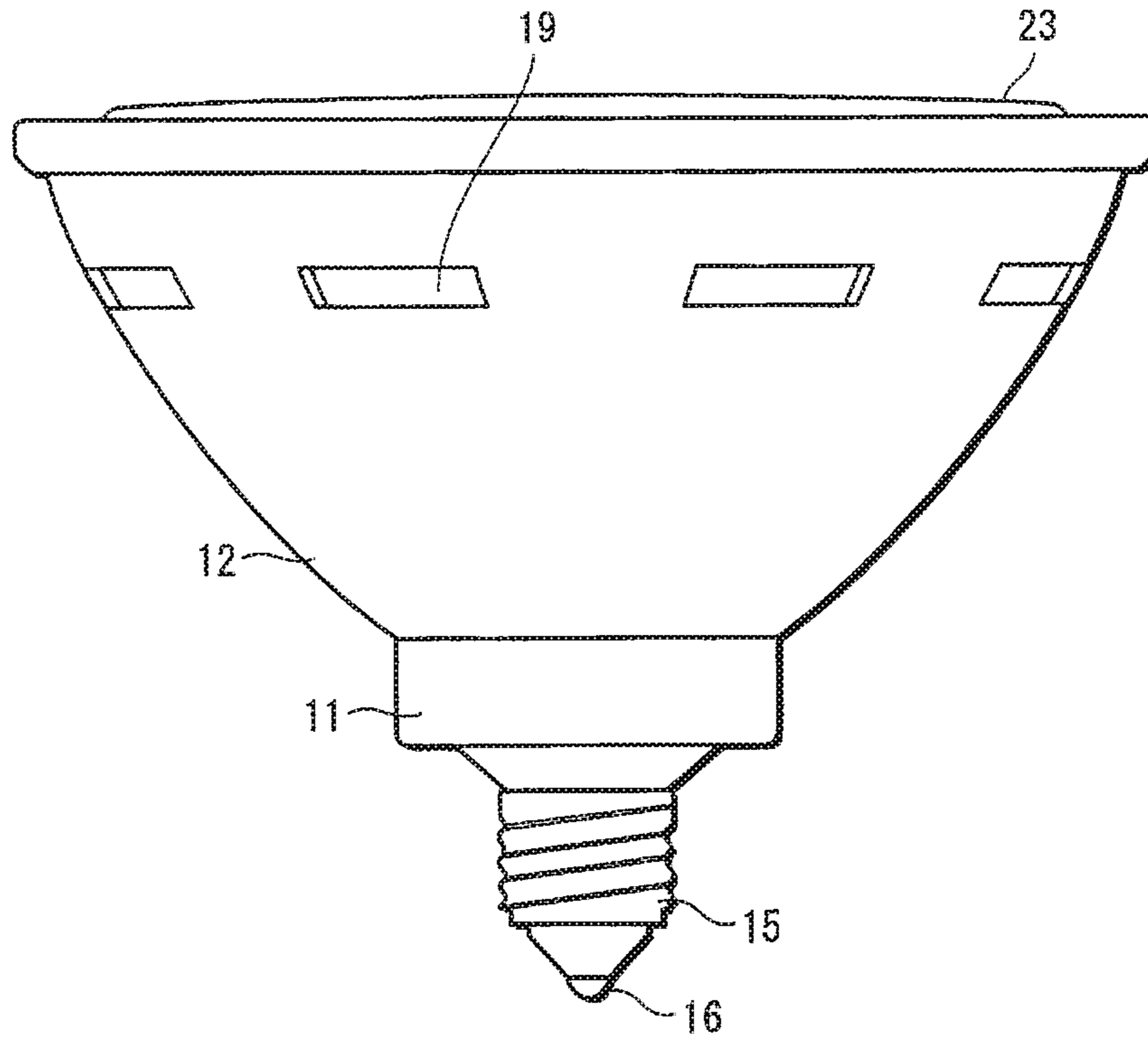

FIG. 10B

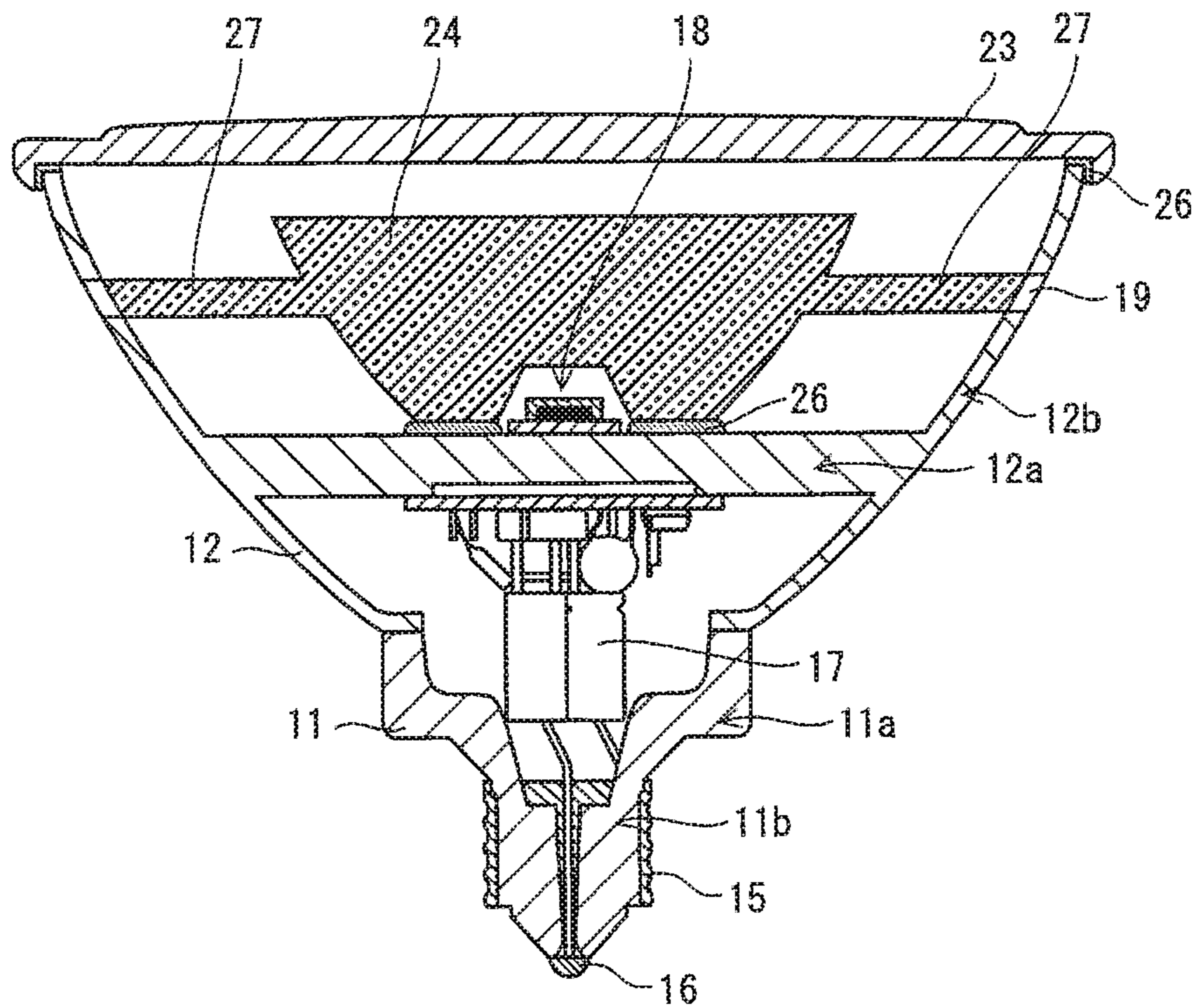

FIG. 11A

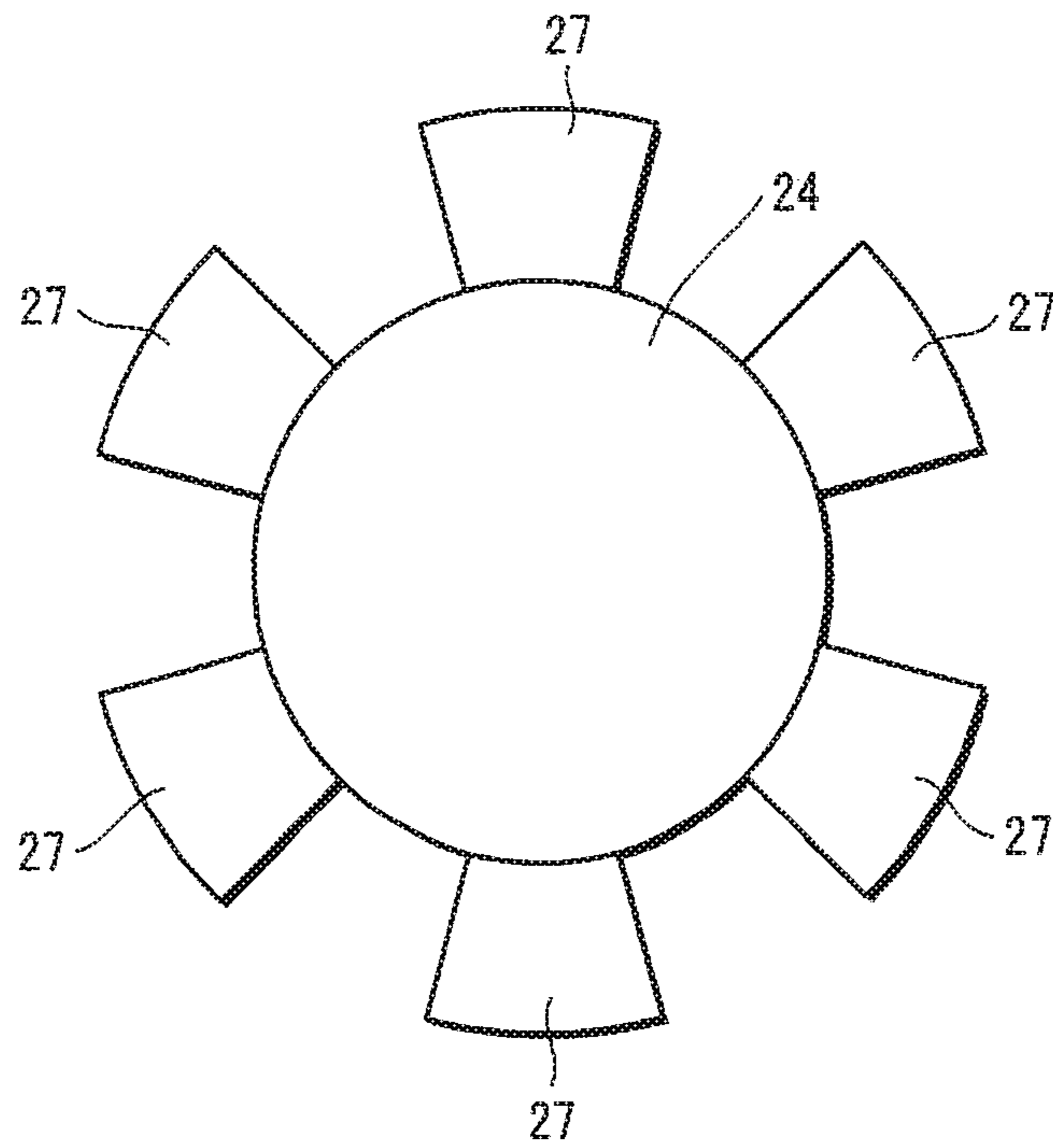

FIG. 11B

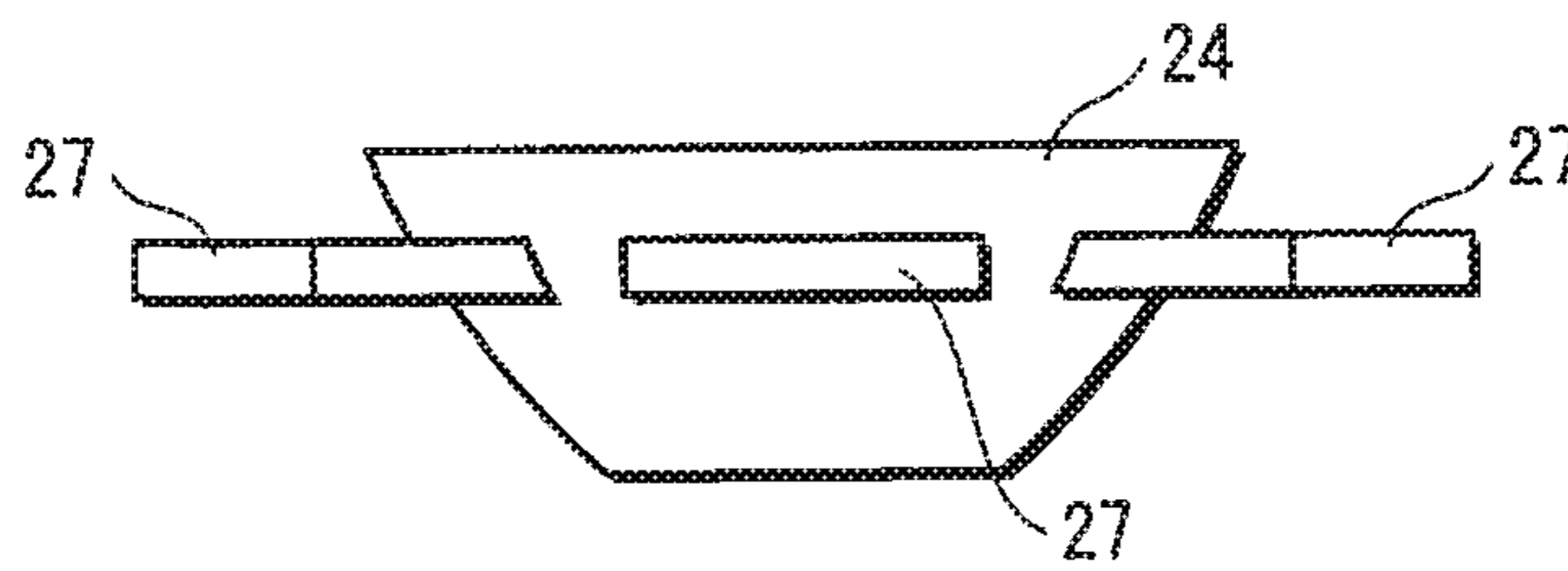

FIG. 11C

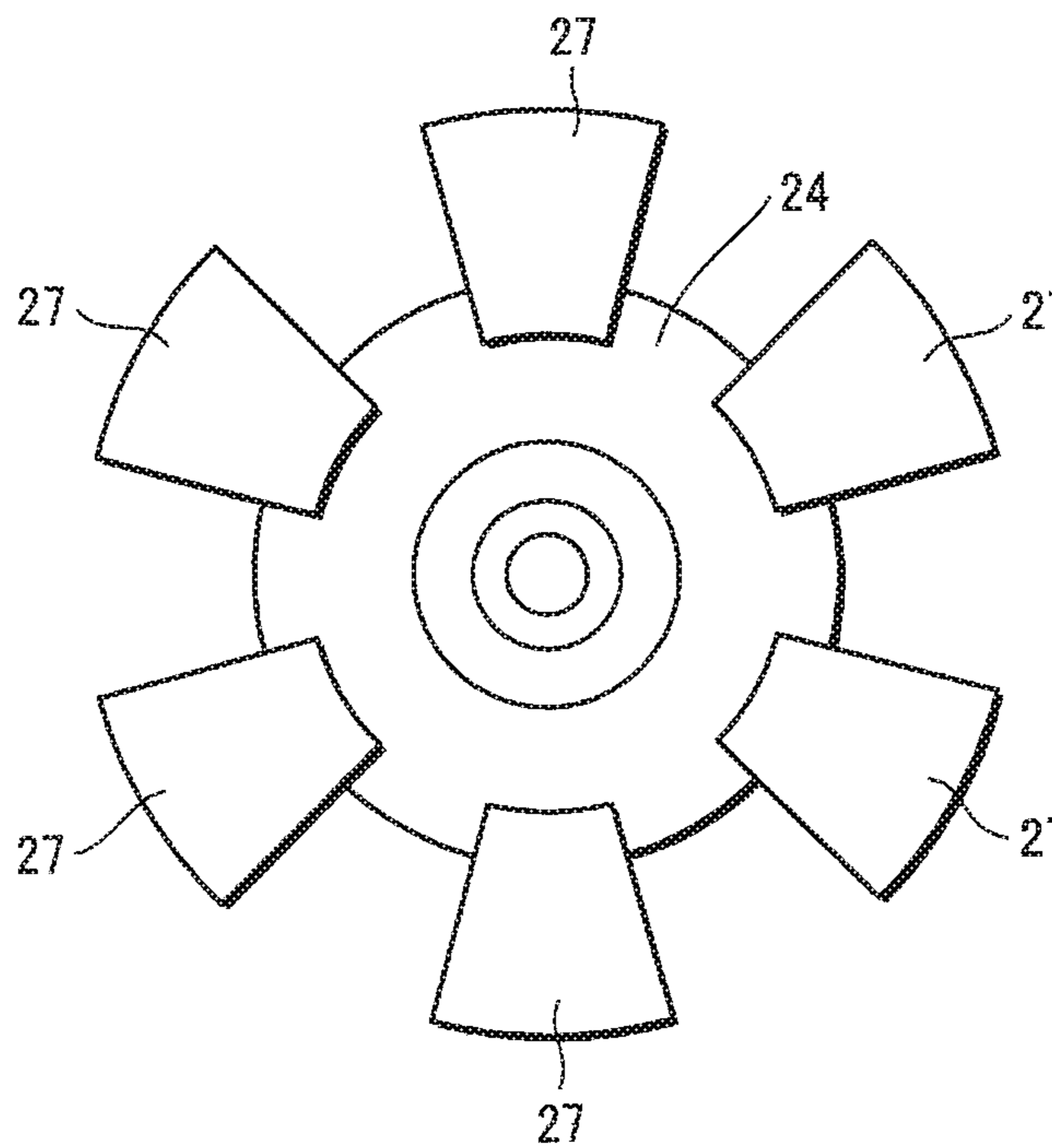

FIG. 12A

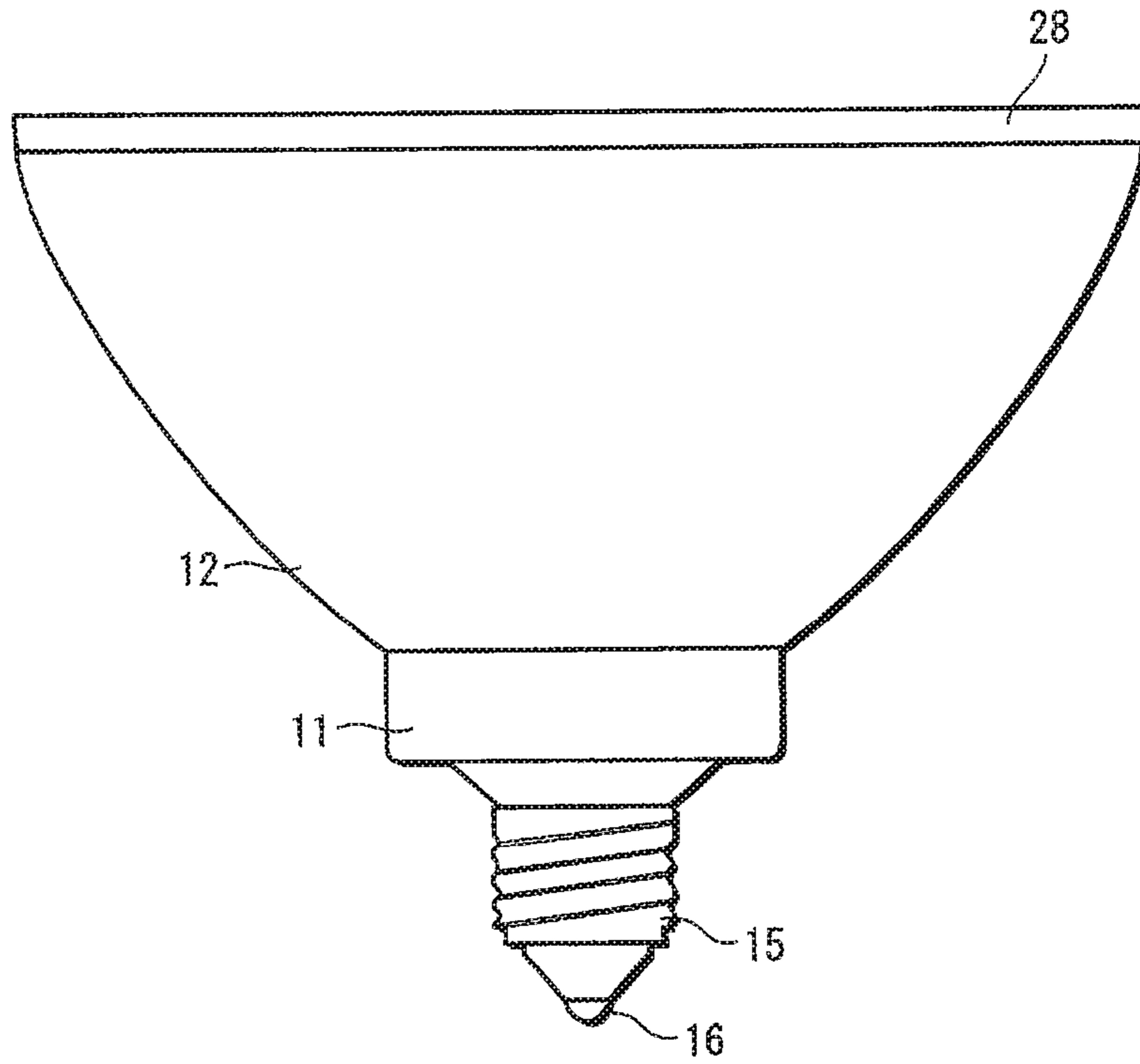

FIG. 12B

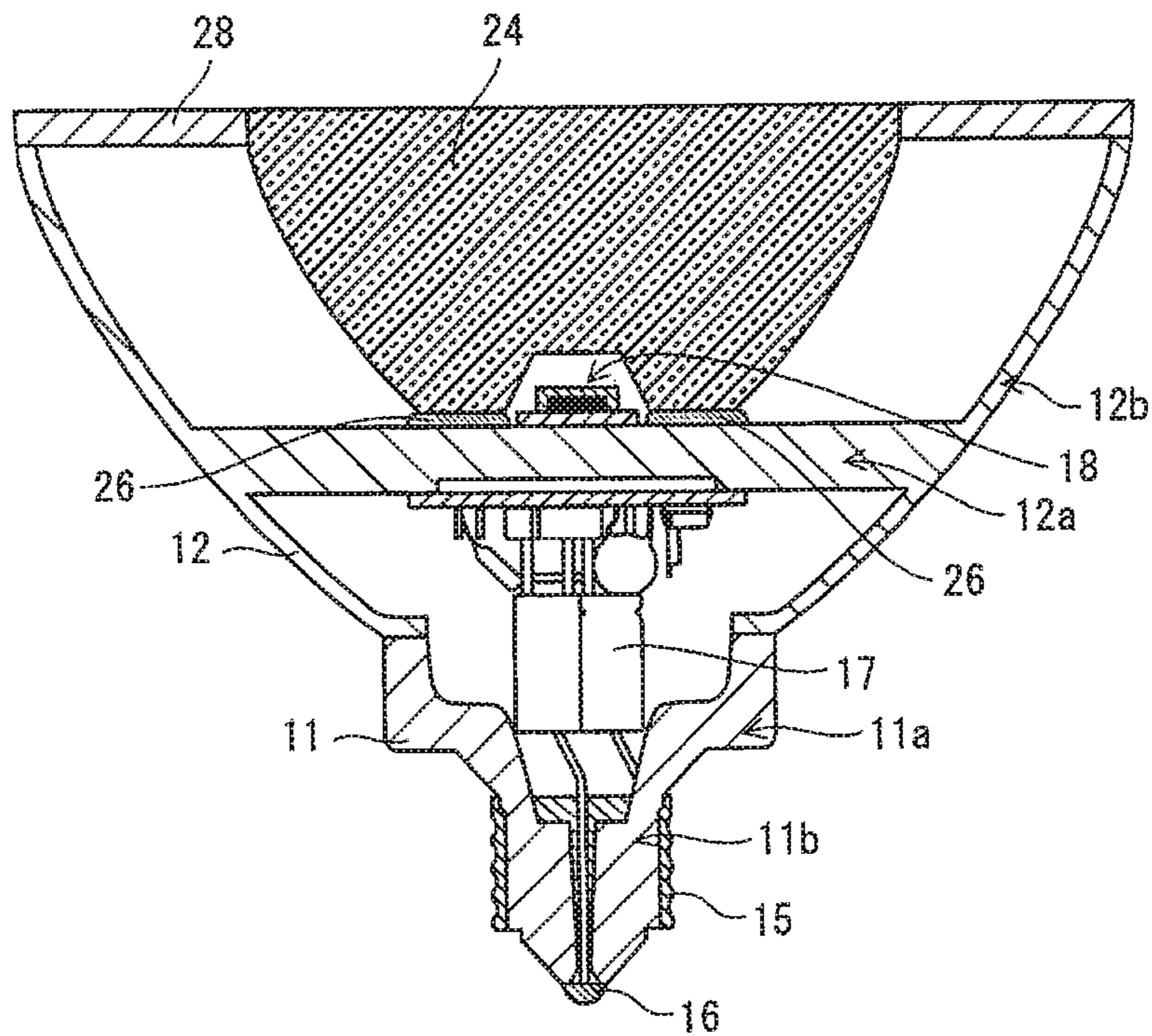

FIG. 13A

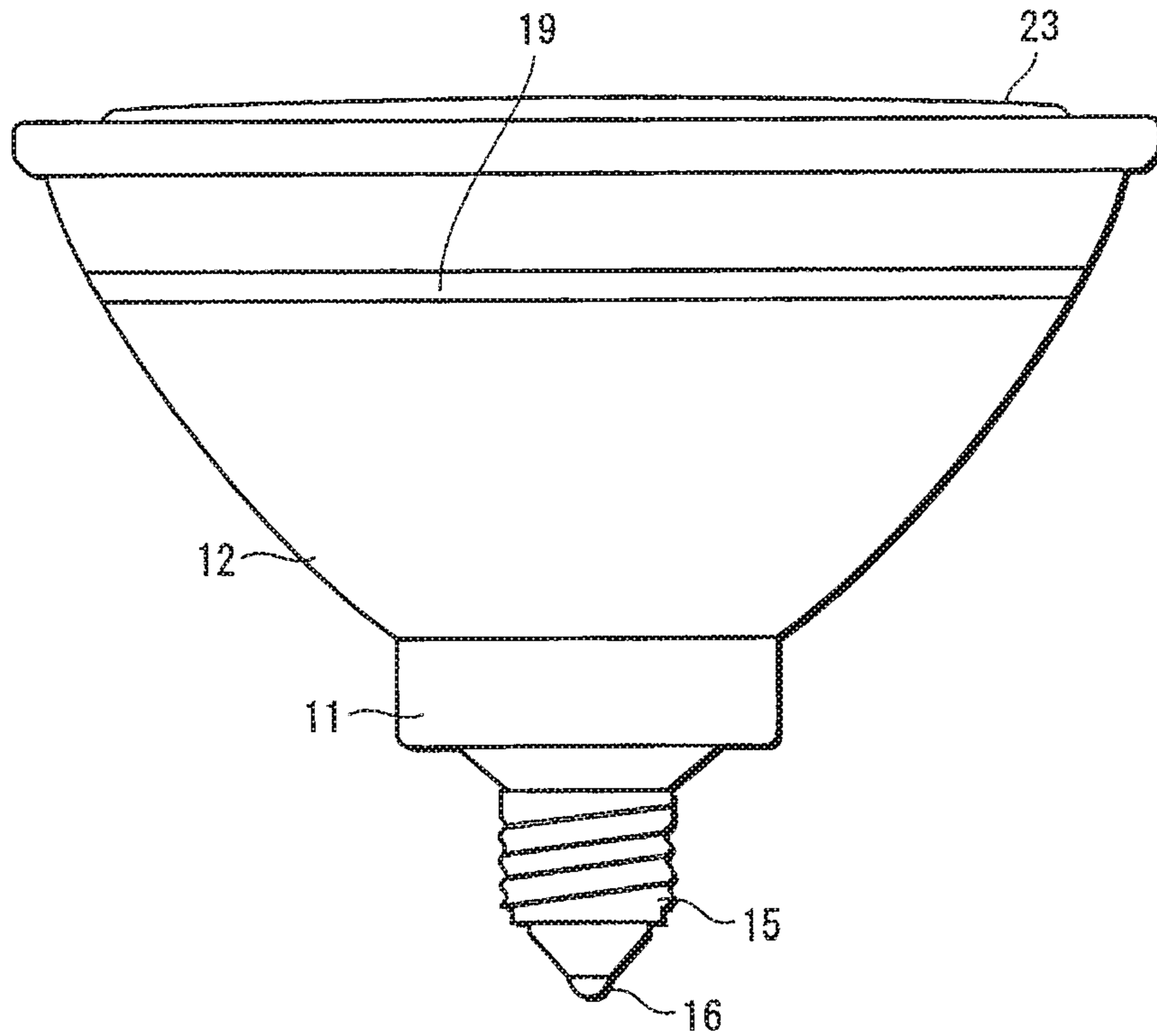

FIG. 13B

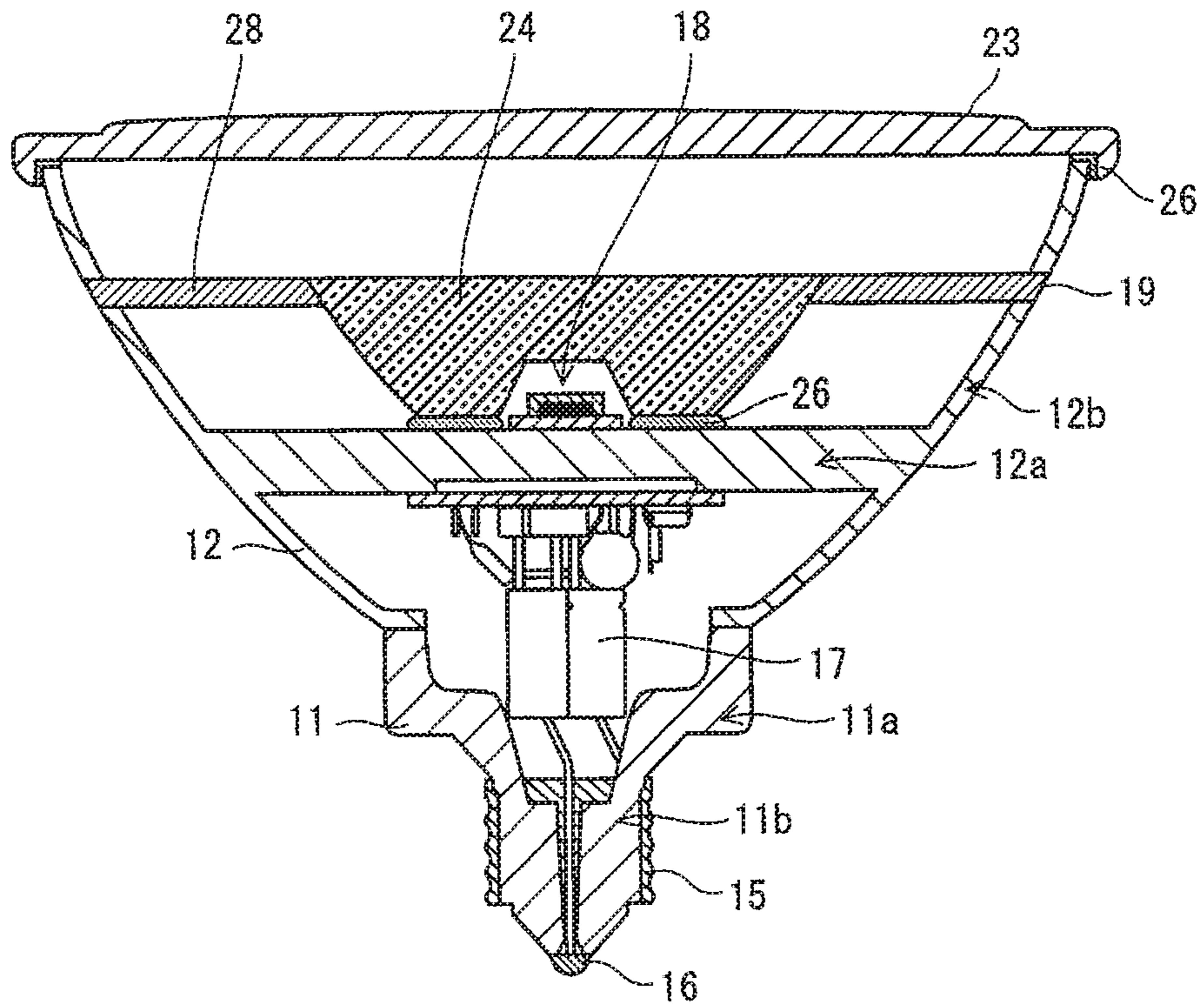

FIG. 14A

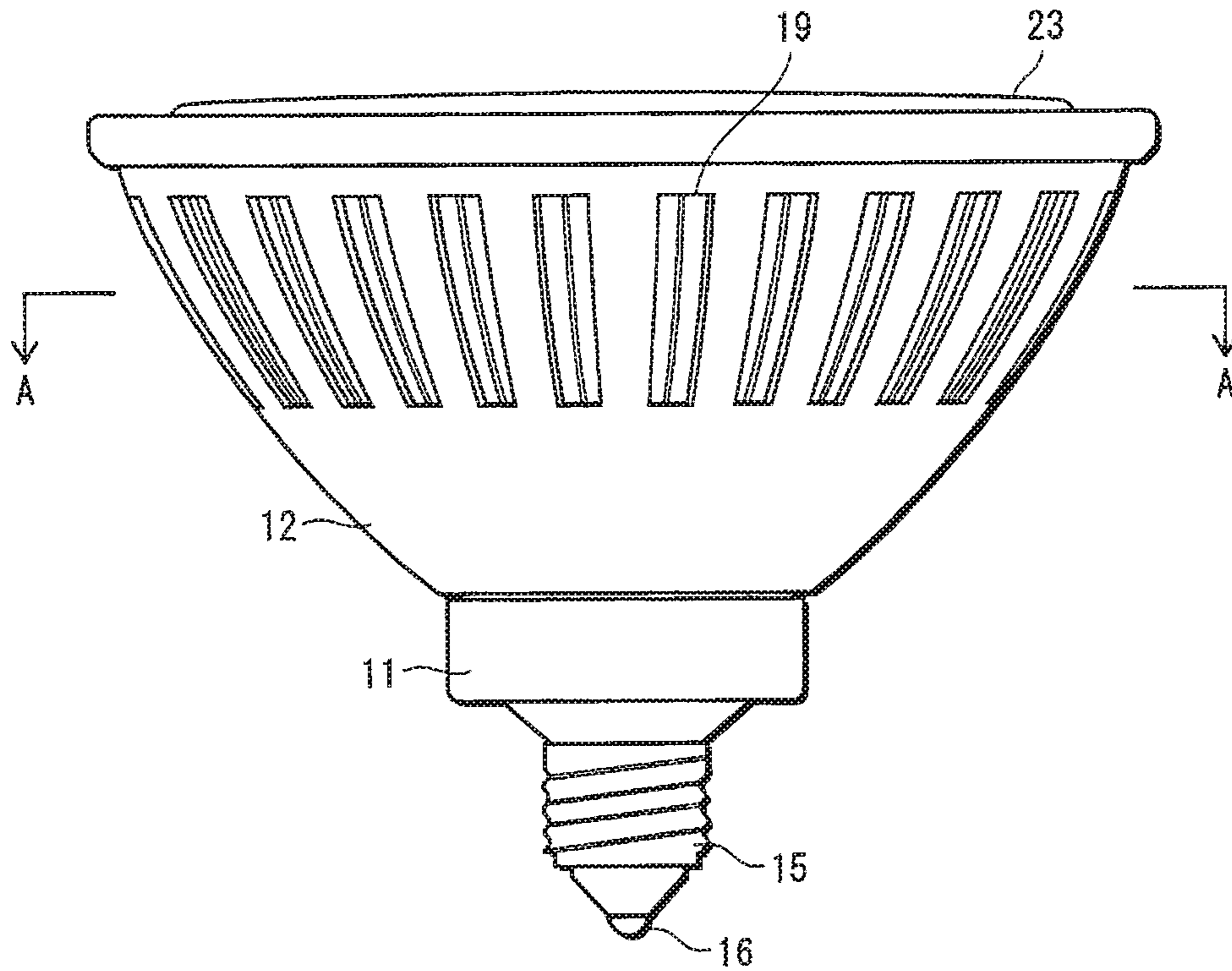

FIG. 14B

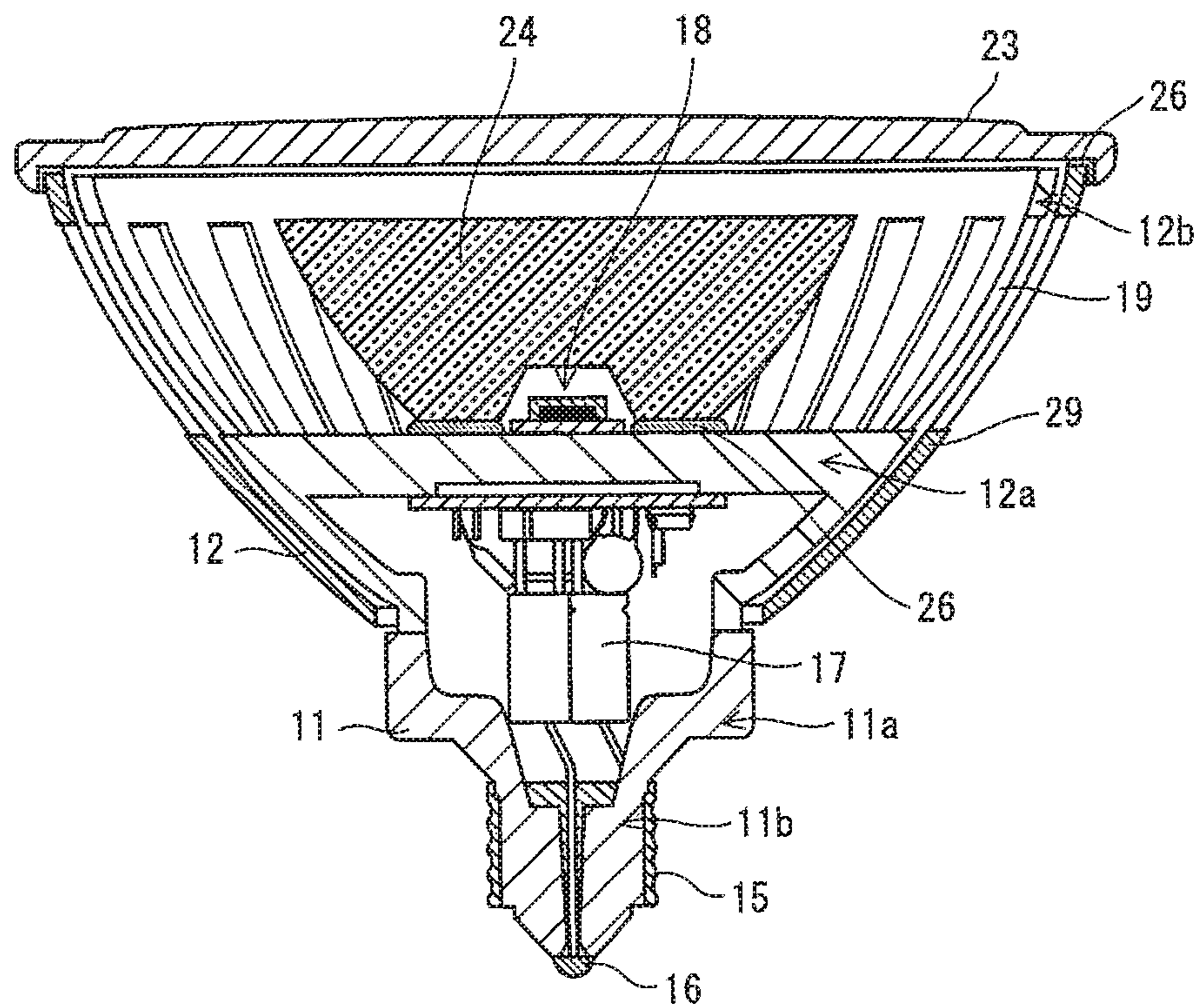

FIG. 15A

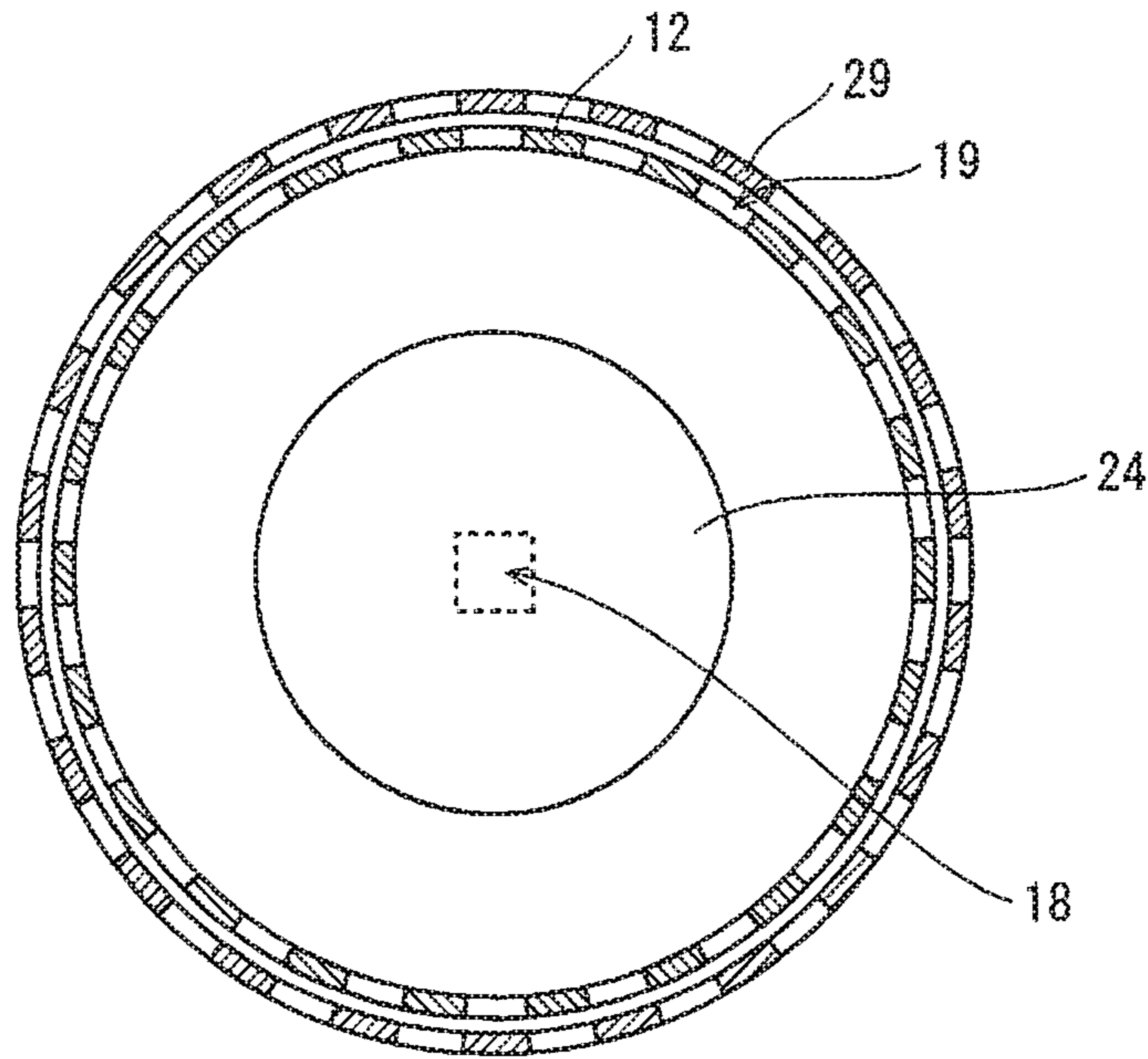

FIG. 15B

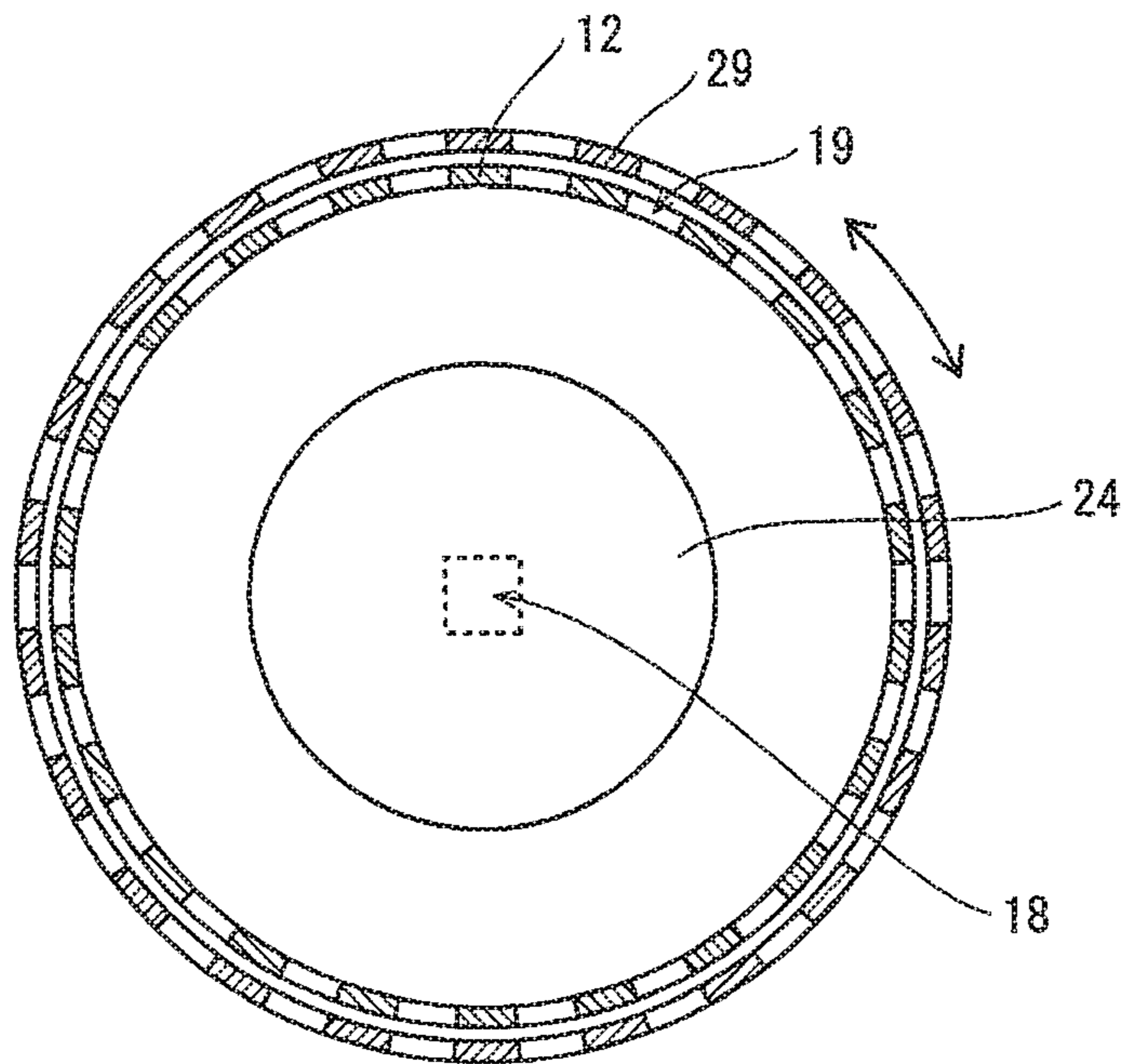



FIG. 16

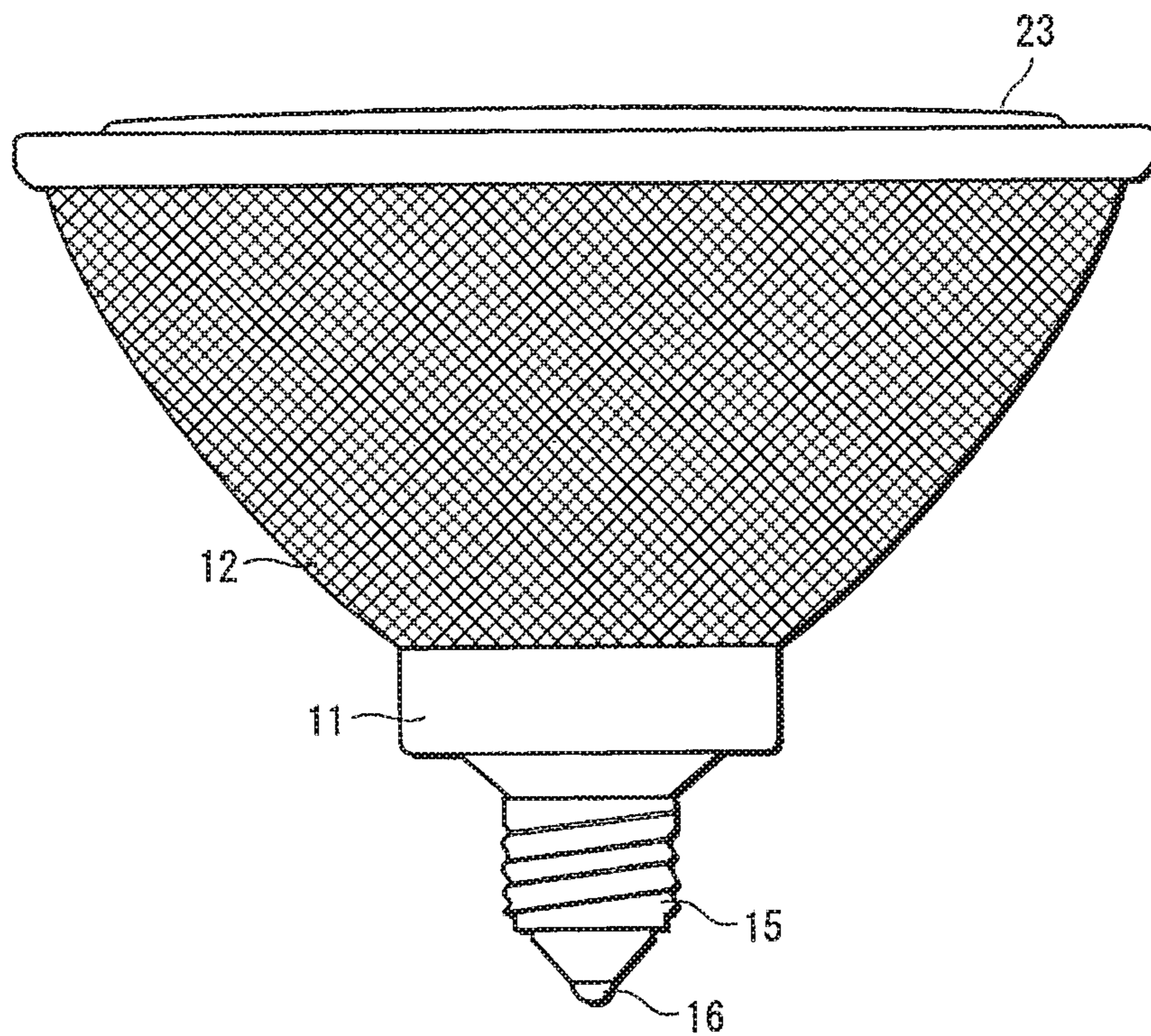

FIG. 17

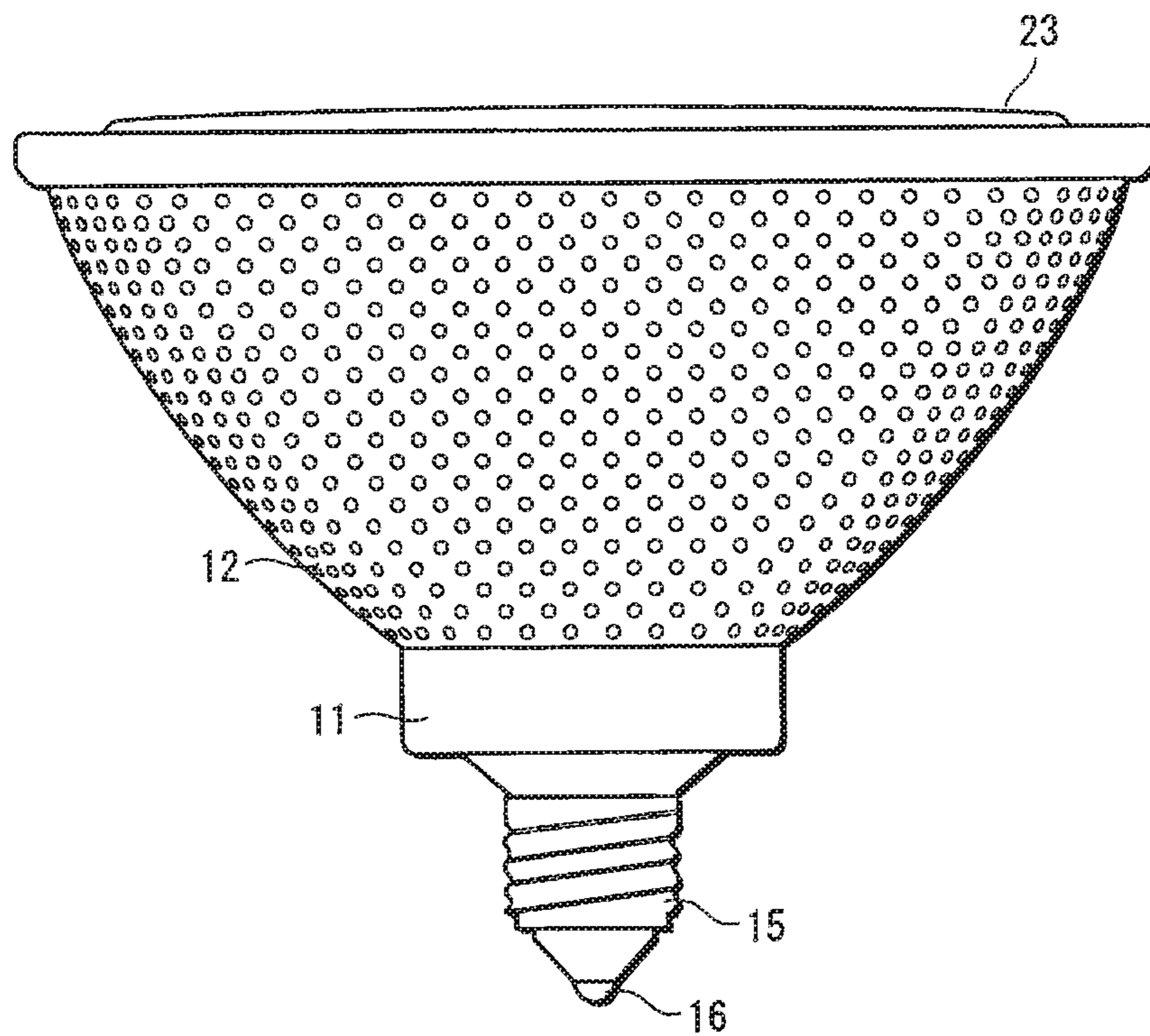



FIG. 19

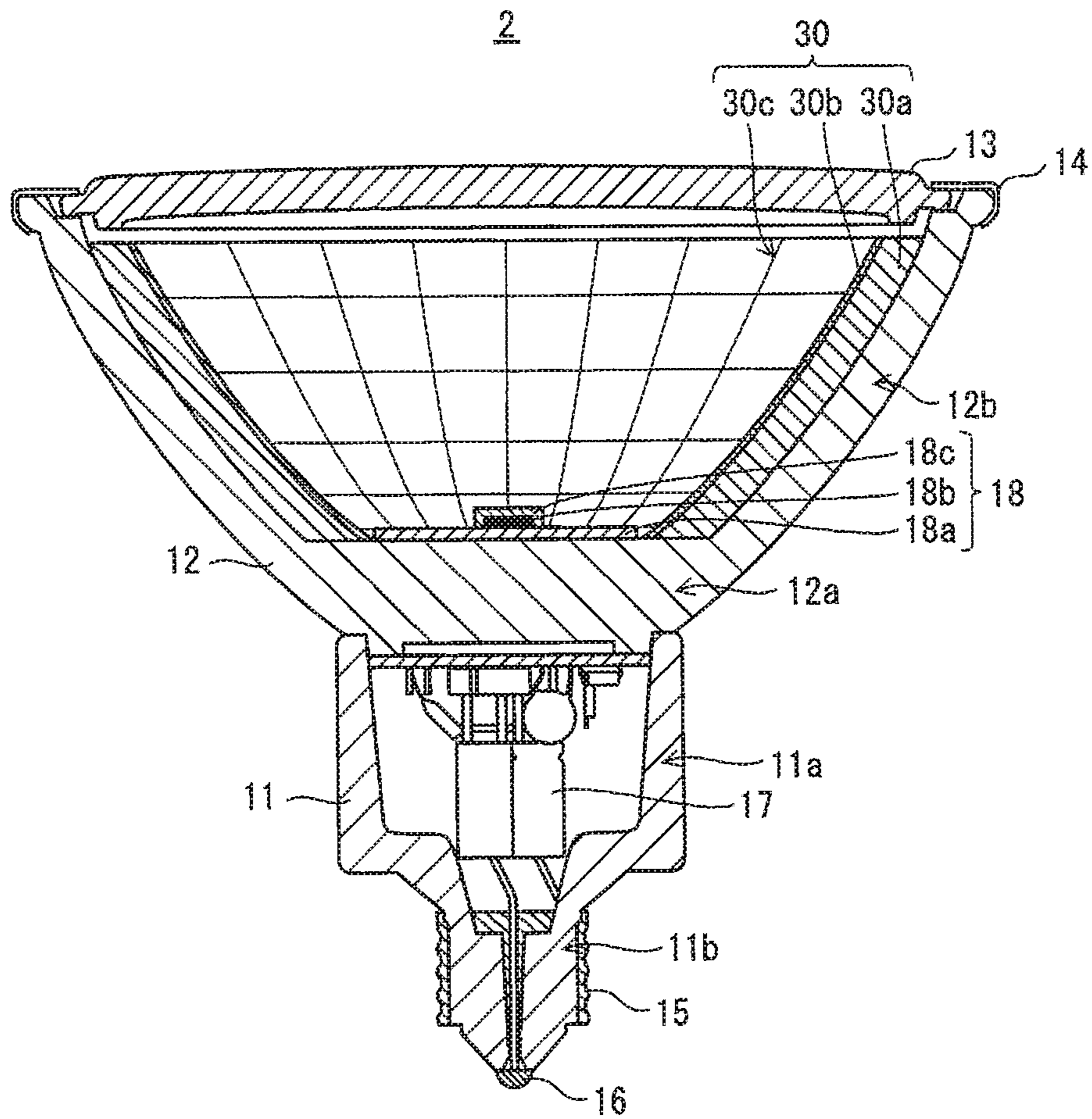

FIG. 20

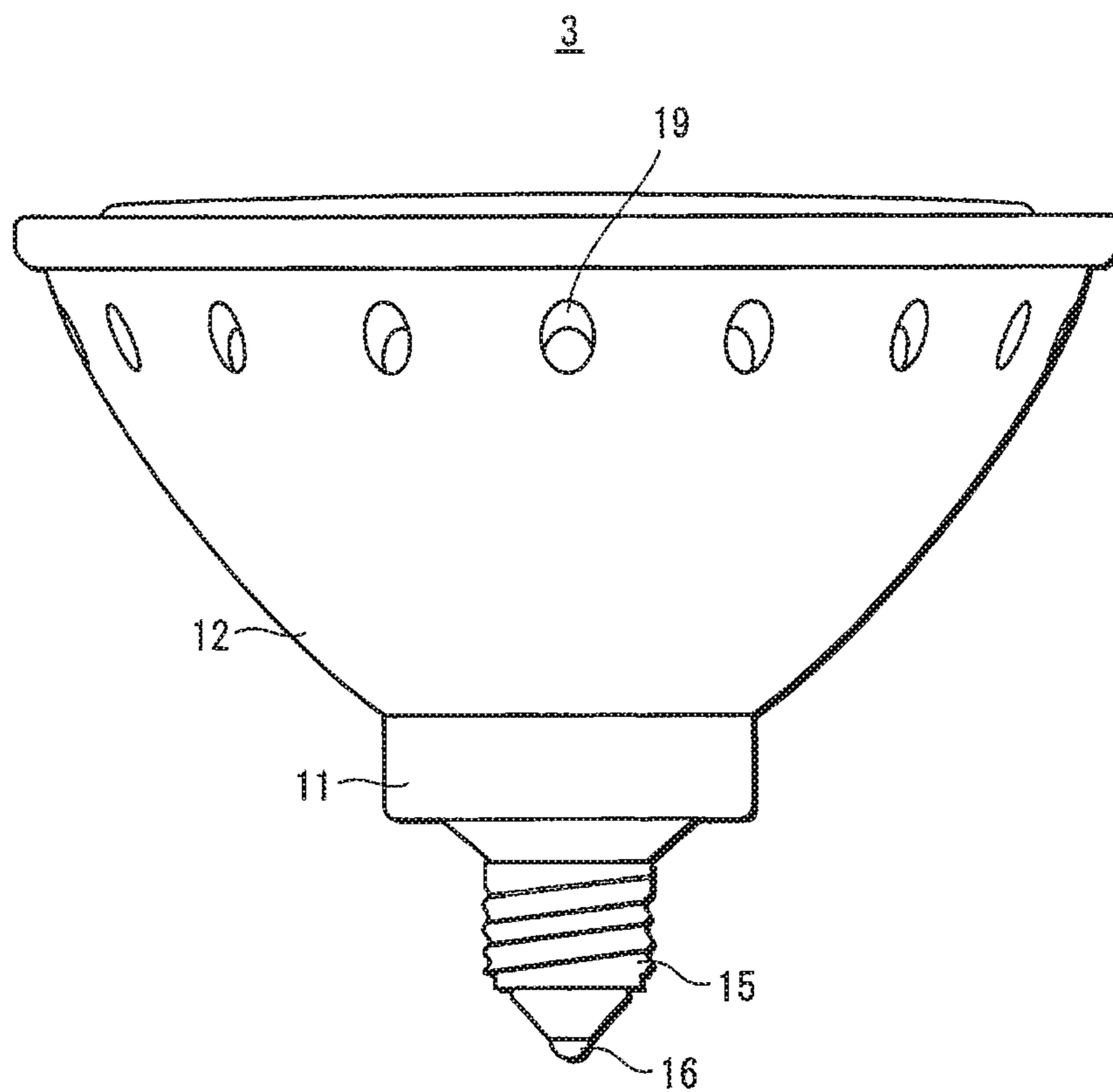
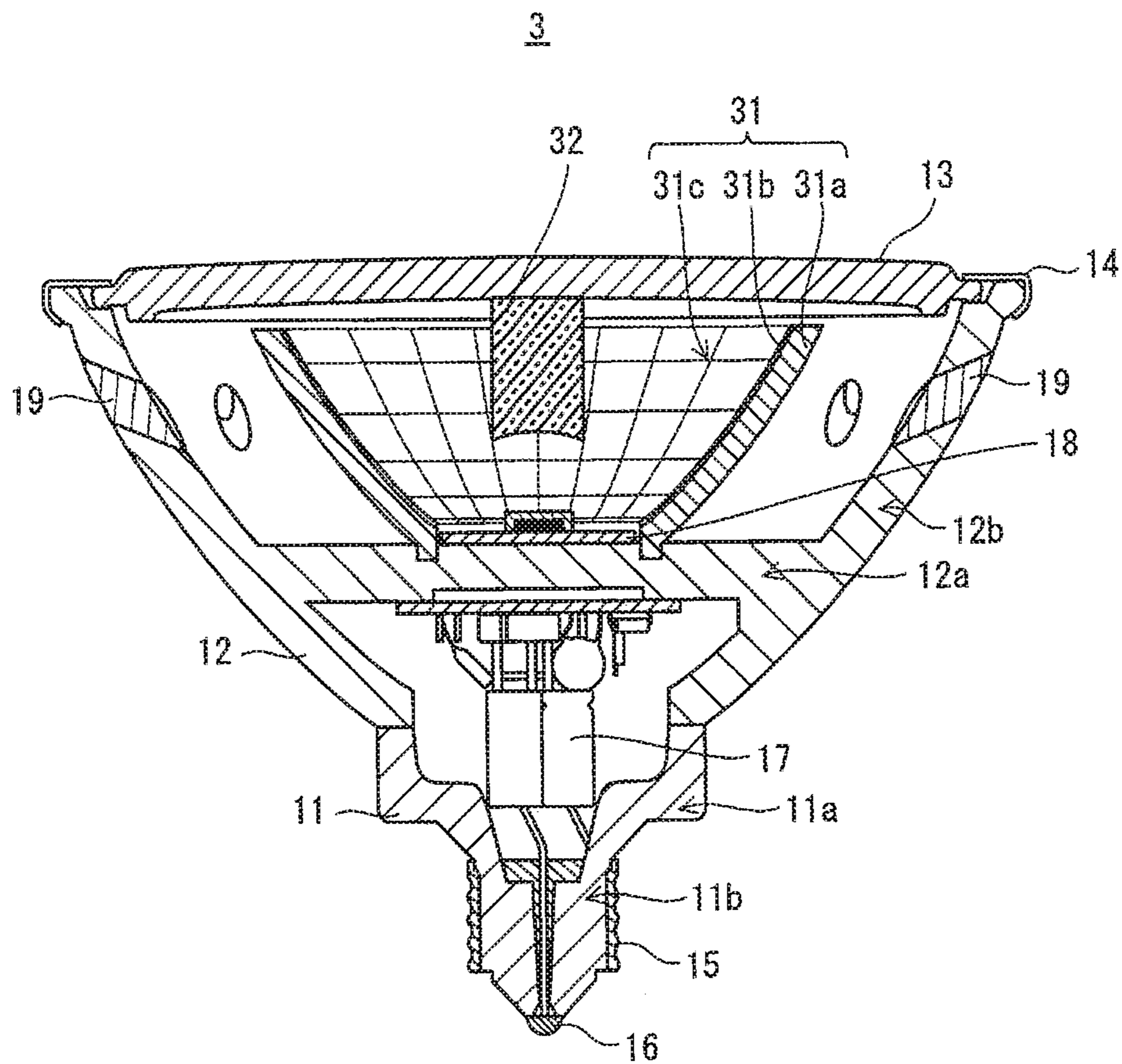

FIG. 21



## ILLUMINATING APPARATUS

**Matter enclosed in heavy brackets [ ] appears in the original patent but forms no part of this reissue specification; matter printed in italics indicates the additions made by reissue; a claim printed with strikethrough indicates that the claim was canceled, disclaimed, or held invalid by a prior post-patent action or proceeding.**

*NOTICE: More than one reissue application has been filed for the reissue of U.S. Pat. No. 8,858,039 B2. The present application is a Reissue Application of U.S. Pat. No. 8,858,039 B2, and is a continuation of Reissue application Ser. No. 15/292,875, filed Oct. 13, 2016, which issued as U.S. Reissued Pat. No. RE47,293 E on Mar. 12, 2019, and which is also a Reissue Application of U.S. Pat. No. 8,858,039 B2.*

## TECHNICAL FIELD

The present invention relates to a lighting apparatus including a light-emitting device such as an LED (Light Emitting Diode).

## BACKGROUND ART

As a lighting apparatus such as spot lighting in a commercial facility or a private residence, a reflector halogen lamp has been widely prevalent.

Meanwhile, importance is placed on saving power consumption and improving life in the field of spot lighting. Accordingly, research and development are carried out on technology for substituting a lighting apparatus including an LED (hereinafter "LED lighting apparatus") for a conventional light bulb. Reflector halogen lamps are no exceptions, and a number of reflector LED lighting apparatuses have been proposed as substitutes for such reflector halogen lamps (see Patent Literatures 1 and 2).

In general, an LED produces heat when lit, and the higher the temperature of the LED is, the lower the light-emitting efficiency of the LED is. Therefore, in the practical application of an LED lighting apparatus, it is an important issue to improve heat dissipation characteristics without violating the size limitation, which requires the LED lighting apparatus to have a size attachable to existing equipment. To address the above issue, technology is proposed that utilizes a reflector LED lighting apparatus also as a heat dissipator by employing a metal reflector (see Patent Literature 3, for example). According to this technology, the heat dissipation characteristics of the reflector LED lighting apparatus are improved without violating the size limitation.

## CITATION LIST

## Patent Literature

[Patent Literature 1]  
Japanese Patent Application Publication No. 2007-317431  
[Patent Literature 2]  
Japanese Registered Utility Model No. 3153732  
[Patent Literature 3]  
Japanese Patent Application Publication No. 2006-202612

## SUMMARY OF INVENTION

## Technical Problem

In a conventional reflector halogen lamp, a reflector is generally made by forming a reflective film (e.g., vapor-

deposited metal film or dielectric multilayer film) on an inner circumferential surface of a bowl-shaped glass base. However, the reflective film is not usually formed on a neck portion of the glass base because the halogen lamp is fixed to the neck portion with use of an adhesive agent. When such a reflector halogen lamp is lit, light of the halogen lamp is emitted from an opening of a reflector, and is also emitted as leaked light from a neck portion that does not include a reflective film. In a commercial facility or the like, the leaked light is positively utilized to enhance "perceived brightness" of the entire space.

However, each of the aforementioned conventional reflector LED lighting apparatuses employs a metal reflector. Therefore, light of an LED is only emitted from an opening of the metal reflector, and leaked light is not produced. Accordingly, in the case of positively utilizing leaked light, these reflector LED lighting apparatuses are not suitable as substitutes for conventional halogen lamps.

Also, a reflector halogen lamp is sometimes used as spot lighting in a store or the like. In this case, facets are formed on a reflector of the halogen lamp so as to control light distribution. Accordingly, when an LED lighting apparatus substitutes for such a halogen lamp, it is necessary that facets are also formed on a reflector of the LED lighting apparatus so as to appropriately control light distribution.

However, if a reflector is made of metal, a special processing technique is required to form facets on the reflector, resulting in the manufacturing cost being significantly increased. Furthermore, spot lighting is required to have various light distribution patterns. This means that a different metal reflector needs to be prepared for each light distribution pattern. As a result, an increase in the manufacturing cost becomes even more problematic.

A first object of the present invention is to provide a lighting apparatus that substitutes for a conventional halogen lamp when positively utilizing leaked light.

A second object of the present invention is to provide a technique for controlling light distribution at low cost while maintaining high heat dissipation characteristics.

## Solution Problem

A first aspect of the present invention is a lighting apparatus comprising: a heat dissipator that is in one of a bottomed cylindrical shape and a bowl shape, and that has a bottom portion, a circumferential wall portion, and an opening; and a light-emitting device that is provided inside the heat dissipator at the bottom portion and is operable to emit light, wherein the heat dissipator has one or more windows for leaking the emitted light outside the heat dissipator.

A second aspect of the present invention is a lighting apparatus comprising: a heat dissipator that is in one of a bottomed cylindrical shape and a bowl shape, and that has a bottom portion, a circumferential wall portion, and an opening; a light-emitting device that is provided inside the heat dissipator at the bottom portion and is operable to emit light; and a reflector that is bowl-shaped and provided in the heat dissipator, and is operable to reflect the emitted light toward the opening, wherein the reflector is made of a base and a reflective film that covers the base, and the base is made of one of resin and glass, and has facets.

## Advantageous Effects of invention

According to the first aspect of the present invention, the light of the light-emitting device is emitted from the opening

of the heat dissipator that is in one of a bottomed cylindrical shape and a bowl shape, and also leaked outside the heat dissipator through the one or more windows provided in the circumferential wall portion of the heat dissipator. Therefore, the lighting apparatus according to the first aspect of the present invention is suitable as a substitute for a conventional halogen lamp when positively utilizing leaked light.

Also, according to the second aspect of the present invention, the reflector is made of one of resin and glass. This makes it easy to form the facets on the base. Furthermore, since the heat dissipator **12** and the reflector **30** are separate members, a structure is possible where the heat dissipator **12** is commonly used while the reflector **30** is different depending on a light distribution pattern. This makes it possible to control light distribution at lower cost than a conventional structure, while maintaining high heat dissipation characteristics.

#### BRIEF DESCRIPTION OF DRAWINGS

FIG. **1** is a partial cutaway view showing a structure of a lighting apparatus according to Embodiment 1 of the present invention.

FIG. **2** shows a modification pertaining to the shape of windows provided in a heat dissipator.

FIG. **3** shows a modification pertaining to the shape of the windows provided in the heat dissipator.

FIG. **4** shows a modification pertaining to the positional relationship between a bottom portion and circumferential wall portion of the heat dissipator.

FIGS. **5A** and **5B** are a side view and a bottom view, respectively, showing a modification pertaining to the arrangement of the windows provided for the heat dissipator.

FIGS. **6A**, **6B**, and **6C** each show a modification pertaining to the shape of the dissipator.

FIG. **7** shows a modification pertaining to a structure where the windows provided for the heat dissipator are closed off.

FIGS. **8A** and **8B** are a side view and a sectional view, respectively, showing a modification pertaining to the structure where the windows provided for the heat dissipator are closed off.

FIGS. **9A** and **9B** are a side view and a sectional view, respectively, showing a modification pertaining to the structure where the windows provided for the heat dissipator are closed off.

FIGS. **10A** and **10B** are a side view and a sectional view, respectively, showing a modification pertaining to a structure for guiding light toward the windows provided for the heat dissipator.

FIGS. **11A**, **11B**, and **11C** are a top view, a side view, and a bottom view, respectively, showing a structure of a lens and a light guiding member according to the modification shown in FIGS. **10A** and **10B**.

FIGS. **12A** and **12B** are a side view and a sectional view, respectively, showing an example of the light guiding member also serving as a front cover.

FIGS. **13A** and **13B** are a side view and a sectional view, respectively, showing a modification pertaining to a structure of the windows provided in the heat dissipator.

FIGS. **14A** and **14B** are a side view and a sectional view, respectively, showing a modification pertaining to a structure of the windows provided in the heat dissipator.

FIGS. **15A** and **15B** each show how the opening area of each window is changed, in the modification shown in FIGS. **14A** and **14B**.

FIG. **16** shows a modification pertaining to the shape of the windows provided in the heat dissipator.

FIG. **17** shows a modification pertaining to the shape of the windows provided in the heat dissipator.

FIGS. **18A** and **18B** each show a modification pertaining to a structure of the opening of the heat dissipator.

FIG. **19** is a sectional view showing a structure of a lighting apparatus according to Embodiment 2 of the present invention.

FIG. **20** is a side view showing a structure of a lighting apparatus according to Embodiment 3 of the present invention.

FIG. **21** is a sectional view showing the structure of the lighting apparatus according to Embodiment 3 of the present invention.

#### DESCRIPTION OF EMBODIMENTS

The following describes embodiments of the present invention, with reference to the drawings.

##### Embodiment 1

FIG. **1** is a partial cutaway view showing a structure of a lighting apparatus according to Embodiment 1 of the present invention.

A lighting apparatus **1** includes, as main components thereof, a case **11**, a heat dissipator **12**, and a light-emitting module **18**. First, a schematic structure of each of these components is described. Then, a detailed structure of the heat dissipator **12** is described.

##### <Schematic Structure>

The case **11** is made of an insulating material such as ceramics, and is composed of a cylindrical portion **11a** and a protrusion **11b**. The protrusion **11b** extends from an end of the cylindrical portion **11a**. The cylindrical portion **11a** houses therein a lighting circuit **17**. A shell **15**, which is made of metal, is provided on an outer circumferential surface of the protrusion **11b**. An end of the protrusion **11b** is provided with an eyelet **16**, which is also made of metal. Both of the shell **15** and the eyelet **16** are connected to the lighting circuit **17** via wiring lines, and serve as feed terminals that receive power supplied from an external power source.

The heat dissipator **12** is made of a heat dissipating material, and is bowl-shaped with a bottom portion **12a** and a circumferential wall portion **12b**. The circumferential wall portion **12b** extends from the rim of the bottom portion **12a**. The heat dissipating material may be, for example, a metal material such as aluminum, a non-translucent ceramic material, a non-translucent resin material, or a combination of these materials (e.g., multilayer structure). In general, a resin material has lower heat conductivity than a metal material or a ceramic material. However, it is possible to use a resin material as a heat dissipating material, as long as the heat value of the light-emitting module **18** is relatively low. In the case of using a resin material, it is more preferable to employ a highly heat-conductive resin. The light-emitting module **18** is fixed to an inner surface of the bottom portion **12a** of the heat dissipator **12**, with use of an adhesive agent having heat conductivity. The case **11** is fixed to an outer surface of the bottom portion **12a**, with use of the adhesive agent. An opening of the heat dissipator **12** is covered by a front cover **13**, with use of a metal fitting **14**. The front cover **13** is made of a translucent material. The translucent material may be, for example, resin, glass, or ceramics. The circumferential wall portion **12b** of the heat dissipator **12** has windows **19**



5

through which light emitted from the light-emitting module **18** leaks. An inner circumferential surface of the heat dissipator **12** reflects light except the parts where the windows **19** are provided, so that the heat dissipator **12** also serves as a reflector. The size of the heat dissipator **12** is substantially equal to or smaller than the size of an existing reflector halogen lamp. For example, suppose that the lighting apparatus **1** substitutes for a reflector halogen lamp, and the reflector of the halogen lamp has an opening diameter in a range of approximately 50 mm to 70 mm. In this case, the opening diameter of the heat dissipator **12** may be in the range of approximately 50 mm to 70 mm or smaller.

The light-emitting module **18** is composed of a metal substrate **18a**, an LED device **18b**, a silicone resin member **18c**, and a lens **18d**. The metal substrate **18a** is formed in the following manner. First, an insulating film, such as a resin film, is formed on an upper surface of a metal base, such as copper. Next, a wiring pattern is formed on the insulating film. The wiring pattern is connected to the lighting circuit **17** by a wiring line. The LED device **18b** is a so-called blue light-emitting diode, and is mounted on the wiring pattern formed on the metal substrate **18a**. The silicone resin member **18c** is formed to enclose the LED device **18b**, and is made by dispersing yellow phosphor in a silicone resin. The LED device **18b** is combined with the silicone resin member **18c** so as to obtain white light. The lens **18d** is formed to enclose the silicone resin member **18c**, and is made of a translucent material such as resin. The light-emitting module **18** is arranged such that the optical axis of the light-emitting module **18** coincides with the central axis of the heat dissipator **12** that is bowl-shaped.

The lighting apparatus **1** is used by being mounted in a socket provided in a commercial facility or the like. The light emitted from the light-emitting module **18** is provided as spot lighting after passing through the front cover **13** from the opening of the heat dissipator **12**, and also as leaked light after passing through the windows **19** provided in the circumferential wall portion **12b** of the heat dissipator **12**. This enhances the "perceived brightness" of the entire space of a commercial facility or the like, with use of leaked light.

Also, heat generated by lighting the LED device **18b** is conducted to the heat dissipator **12** via the heat-conductive adhesive agent and the metal substrate **18a** that is a heat-conductive member, thereby dissipating heat effectively.

<Detailed Structure of Heat Dissipator>

As shown in FIG. 1, the circumferential wall portion **12b** of the heat dissipator **12** has the plurality of windows **19**. Some of the windows **19** are arranged in a circumferential area **12c** at equal intervals, and the rest of the windows **19** are arranged in a circumferential area **12d** at equal intervals. The circumferential area **12d** is located closer to an opening edge of the heat dissipator **12** than the circumferential area **12c**. In each of the circumferential areas **12c** and **12d**, the windows **19** are arranged at equal intervals in a circumferential direction. This enables the light distribution of the leaked light to be symmetrical in the circumferential direction.

The windows **19** in the circumferential area **12d** have a size larger than those in the circumferential area **12c**. This makes it possible to leak more light at an angle close to a direction in which spot lighting is emitted, thereby increasing the illuminance in the vicinity of a main irradiation area.

The windows **19** are formed such that through-holes provided in the circumferential wall portion **12b** of the heat dissipator **12** are closed off by translucent members. The translucent members may be made of, for example, resin, glass, or ceramics. Closing off the through-holes by the

6

translucent members prevents foreign substances, such as moisture and dust, from entering the heat dissipator **12**. The translucent members may be colorless or colored. If colored, the translucent members function as color filters. Some conventional halogen lamps have reflectors using dichroic filters. When such halogen lamps are lit, the coloration of leaked light may be specific (e.g., red). Therefore, the translucent members may be colored in a manner that reproduces the specific color, so that the lighting apparatus **1** is more suitable as a substitute for each halogen lamp.

Each of the through-holes of the windows **19** is arranged such that the light-emitting module **18** is located on an extended line of a central axis **19c** of the through-hole. In this way, light emitted from the light-emitting module **18** is leaked from the windows **19**, thus improving the "perceived radiance" of the lighting apparatus **1**.

Note that in a conventional halogen lamp, the light distribution is controlled by a reflector, whereas in the lighting apparatus **1**, the light distribution is mainly controlled by the lens **18d**. As a result, in the lighting apparatus **1**, direct light from the light-emitting module **18** greatly contributes to spot lighting, but reflected light on the inner circumferential surface of the heat dissipator **12** does not contribute much to the spot lighting. This means that the windows **19** provided in the circumferential wall portion **12b** of the heat dissipator **12** do not affect the brightness of the spot lighting.

<Modifications>

The following modifications are acceptable in Embodiment 1 described above.

(1) According to Embodiment 1, the shape, number, and position of the windows **19**, and the relative size of the windows **19** with respect to the heat dissipator **12** are specifically illustrated. However, the present invention is not limited to such. For example, the windows **19** may be rhombus-shaped and arranged like facets, as shown in FIG. 2. Alternatively, the windows **19** may be slit-shaped and arranged at equal intervals in a circumferential direction, as shown in FIG. 3. In the case where the windows **19** are slit-shaped, each slit does not always need to be a longitudinal slit as shown in FIG. 3, but may be a lateral slit.

(2) According to Embodiment 1, the bottom portion **12a** of the heat dissipator **12** is positioned at an edge of the circumferential wall portion **12b**. However, the present invention is not limited to such. For example, the bottom portion **12a** may be positioned at a middle part of the circumferential wall portion **12b**, as shown in FIG. 4. This makes it possible to provide a larger space for housing the lighting circuit **17**. In this case, the windows **19** are provided in an area of the circumferential wall portion **12b**, which is located between a virtual plane including the opening of the heat dissipator **12** and a virtual plane that is perpendicular to the central axis of the heat dissipator **12** and passes through the light-emitting module **18**.

(3) According to Embodiment 1, the windows **19** are provided along the entire circumference of the circumferential wall portion **12b**. However, the present invention is not limited to such. For example, the windows **19** may be provided in a part of the circumferential wall portion **12b** in the circumferential direction, as shown in FIGS. 5A and 5B. This enables the light distribution of the leaked light to be asymmetrical in the circumferential direction. Providing the windows **19** in such a manner is particularly useful when feed pins **20** are employed as feed terminals, as shown in FIGS. 5A and 5B. This is because the direction of the lighting apparatus **1** is fixed when attached to equipment.

(4) According to Embodiment 1, the heat dissipator **12** is bowl-shaped, where the outer circumference of the circumferential wall portion **12b** becomes larger from the bottom portion toward the opening edge, and the outer circumference converges to a constant value as it nears the opening edge. However, the present invention is not limited to such as long as the heat dissipator **12** can house the light-emitting module **18**. For example, the heat dissipator **12** may be cylinder-shaped where the outer circumference of the circumferential wall portion is approximately constant from the bottom portion to the opening edge, as shown in FIG. **6A**. Also, the heat dissipator **12** may be bowl-shaped where the circumferential wall portion **12b** extends outwardly at a constant rate, as shown in FIG. **6B**. Furthermore, the heat dissipator **12** may be bowl-shaped where the circumferential wall portion **12b** extends outwardly and the outer circumference thereof increases as it nears the opening edge, as shown in FIG. **6C**. Also, the shape of the heat dissipator **12** may be a shape obtained by combining these shapes.

(5) Although the plurality of windows **19** are provided in Embodiment 1, the effect of the present invention is obtained as long as at least one of the windows **19** is provided.

(6) According to Embodiment 1, the windows **19** are formed by closing off the through-holes by the translucent members. However, the present invention is not limited to such as long as the windows **19** transmit light. For example, the windows **19** may be through-holes which are not closed off by the translucent members.

(7) According to Embodiment 1, the windows **19** have a structure where the translucent members are fit in the through-holes. However, the present invention is not limited to such in view of preventing the entrance of foreign substances. For example, it is possible to provide a circumferential cover, which is made of a translucent material, on one of inner and outer surfaces of the heat dissipator, or on both surfaces thereof, instead of fitting the translucent members in the through-holes. FIG. **7** shows an example where a circumferential cover **21** is provided on the inner surface of the heat dissipator **12**. The circumferential cover **21** may be, for example, a molded product made of a translucent material or a sheet that is made of a translucent material and adhered to the inner surface of the heat dissipator **12**. The translucent material may be, for example, resin, glass, or ceramics. Also, the circumferential cover **21** does not need to cover the entire inner surface of the heat dissipator **12**, and may cover at least the openings of the windows **19**. FIGS. **8A** and **8B** each show an example where a molded product **22** is provided for the heat dissipator **12**. The molded product **22** is formed by integrating a front cover **23**, a lens **24**, and a circumferential cover **25**. The molded product **22** and the heat dissipator **12** are fixed with use of an adhesive agent **26**. Integration in the aforementioned manner simplifies the manufacturing process. In this example, the light-emitting module **18** does not include the lens. FIGS. **9A** and **9B** each show an example where projections **25a**, each in the shape of a four-sided pyramid, are provided at positions of the circumferential cover **25** that correspond to the windows **19**. In this way, light that passes through the windows **19** is scattered by the projections **25a**, thereby further improving the "perceived radiance" of the lighting apparatus **1**. The shape of the projections **25a** is not limited to a four-sided pyramid. For example, the projections **25a** may be in the shape of another polygonal pyramid (e.g., a three-sided pyramid, a five-sided pyramid, or a six-sided pyramid) or in the shape of a cone. In this example, the molded product **22**

is formed by integrating the front cover **23** and the circumferential cover **25**, but the lens **24** is provided separately from the molded product **22**.

(8) According to Embodiment 1, the direction of the central axis of each window **19** is set such that the light-emitting module **18** is located on the extended line of the central axis. However, the present invention is not limited to such as long as the windows **19** leak light. For example, the central axis of each window **19** may be perpendicular to a surface of the circumferential wall portion **12b** or to the central axis of the heat dissipator **12** that is bowl-shaped (an optical axis of the light-emitting module **18**).

(9) According to Embodiment 1, the light-emitting device is an LED device. However, the present invention is not limited to such. For example, the light-emitting device may be an organic EL device.

(10) According to Embodiment 1, the heat dissipator **12** also serves as a reflector. However, the present invention is not limited to such. For example, a black coating material may be applied to the inner circumferential surface of the heat dissipator **12**, so that the inner circumferential surface is not reflective.

(11) According to Embodiment 1, the windows **19** are provided in the circumferential wall portion **12b** of the heat dissipator **12**. However, it is not limited to such. The windows **19** may be provided at the bottom portion **12a** of the heat dissipator **12**. In the case of providing, the windows **19** at the bottom portion **12a**, the windows **19** need to be provided in an area not covered by the case **11** so as to leak light outside.

(12) According to Embodiment 1, only the light naturally reached the windows **19** is leaked from the windows **19**. However, the present invention is not limited to such. For example, light may be positively guided toward the windows **19**. FIGS. **10A** and **10B** each show an example where light guiding members **27**, which guide light emitted from the light-emitting module **18** toward the windows **19**, are provided in the heat dissipator **12**. The light guiding members **27** are made of a translucent material. The light guiding members **27** are provided at positions that are on the circumferential surface of the lens **24**, and that correspond to the windows **19**. FIGS. **11A**, **11B**, and **11C** each show an example of the structure of the lens **24** and the light guiding members **27** shown in FIGS. **10A** and **10B**. Since the windows **19** in the circumferential wall portion **12b** of the heat dissipator **12** are provided at equal intervals in the circumferential direction, the light guiding members **27** on the circumferential surface of the lens **24** are also provided at equal intervals in the circumferential direction. According to the stated structure, light is positively guided toward the windows **19**, thus increasing the amount of light leaked from the windows **19**. Also, as shown in FIGS. **12A** and **12B**, a light guiding member **28** may also serve as a front cover. In this example, the light guiding member **28** is disc-shaped with an opening at the center, so as to expose a light-emitting surface of the lens **24** from the opening. The light guiding member **28** is made of, for example, translucent ceramics or the like. Also, as shown in FIGS. **13A** and **13B**, the windows **19** may be formed by exposing the circumferential surface of the light guiding member **28** from the circumferential wall portion **12b** of the heat dissipator **12**.

(13) According to Embodiment 1, the opening area of each window **19** is fixed. However, the present invention is not limited to such. For example, the opening area of each window **19** may be changeable. FIGS. **14A** and **14B** each show an example where a shutter **29** is provided so as to change the opening area of each window **19**. As shown in

FIGS. 14A and 14B, the windows 19 that are slit-shaped are provided in the circumferential wall portion 12b of the heat dissipator 12 at equal intervals in the circumferential direction. The shutter 29 is made of a metal material, such as aluminum, or a non-translucent ceramic material. The shutter 29 is in the shape of a cylinder that fits on an outer surface of the circumferential wall portion 12b of the heat dissipator 12. Also, the shutter 29 has slit-shaped through-holes at positions corresponding to the windows 19. The circumferential wall portion 12b of the heat dissipator 12 is fixed to the case 11, but not to the front cover 23. On the other hand, the shutter 29 is not fixed to the case 11, but to the front cover 23. This realizes a structure where the shutter 29 is rotatable in the circumferential direction of the circumferential wall portion 12b. By rotating the shutter 29, the positional relationship between the windows 19 of the circumferential wall portion 12b and the through-holes of the shutter 29 is changed. This enables changing the opening area of each window 19. FIGS. 15A and 15B each show how the opening area of each window 19 is changed. By changing the opening area of each window 19, the amount of light leaked from the circumferential wall portion 12b of the heat dissipator 12 is adjusted.

In the above example, the shutter 29 is in contact with the outer surface of the circumferential wall portion 12b of the heat dissipator 12. However, it is not limited to such. For example, the shutter 29 may be in contact with the inner surface of the circumferential wall portion 12b. Also, in a case where the heat dissipator 12 is cylinder-shaped as shown in FIG. 6A, the opening area of each window 19 may be changed by sliding the shutter 29 in a direction of a cylindrical axis of the heat dissipator 12. Also, the windows 19 do not always need to be slit-shaped, and may take any shape.

(14) According to Embodiment 1, the windows 19 are formed by providing through-holes in the circumferential wall portion 12b of the heat dissipator 12. However, the present invention is not limited to such. For example, the circumferential wall portion of the heat dissipator 12 may be formed by a metal mesh, as shown in FIG. 16. Alternatively, the circumferential wall portion of the heat dissipator 12 may be formed by a punching metal, as shown in FIG. 17. According to this structure, light is leaked from the entire circumferential wall portion of the lighting apparatus 1. Leaking the light in such a manner is similar to how the light of a conventional reflector halogen lamp is leaked. Also, it is possible to reduce the weight of the entirety of the lighting apparatus, compared to Embodiment 1. Furthermore, since the heat dissipator 12 has a number of small through-holes, the flow speed of air that passes from the inside to the outside of the heat dissipator 12 by convection is increased, thus improving heat dissipation effect. In the case of the metal mesh, the diameter of wire is preferably in the range of 0.1 mm to 0.5 mm. In the case of the punching metal, the diameter of each punching hole is preferably in the range of 0.1 mm to 2.0 mm. Also, in the case of the punching metal, the area of the through-holes with respect to the surface area of the heat dissipator 12 is preferably less than or equal to 50%.

(15) According to Embodiment 1, the light-emitting module 18 includes the metal substrate. However, the present invention is not limited to such as long as the heat conductivity is relatively high. For example, the light-emitting module 18 may include a ceramics substrate instead of the metal substrate.

(16) According to Embodiment 1, light is emitted from the entire area of the opening of the heat dissipator 12. However,

the present invention is not limited to such, and light may be emitted from a part of the area of the opening of the heat dissipator 12. FIGS. 18A and 18B each show a modification pertaining to a structure of the opening of the heat dissipator. The front cover 13 is made of a non-translucent material, and is disc-shaped with an opening at the center, so as to expose a light-emitting surface of the lens 24 from the opening. The non-translucent material may be, for example, a metal material, a non-translucent ceramic material or a non-translucent resin material. In the case of employing a highly heat conductive material, such as a metal material, the heat dissipation characteristics of the lighting apparatus are improved.

Also, in this example, protrusions 24a are provided on a circumferential surface of the lens 24 in a manner that the protrusions 24a make contact with the front cover 13. This makes it possible to firmly fix the lens 24.

#### Embodiment 2

FIG. 19 is a sectional view showing a structure of a lighting apparatus according to Embodiment 2 of the present invention.

A lighting apparatus 2 mainly includes the case 11, the heat dissipator 12, the light-emitting module 18, and a reflector 30. Embodiment 2 is different from Embodiment 1 in that: windows are not formed in the heat dissipator 12; the light-emitting module 18 does not include any lens; and the lighting apparatus 2 includes the reflector 30. Aside from these differences, Embodiment 2 has the same structure as Embodiment 1; therefore, descriptions thereof are omitted.

The reflector 30 is fixed inside the heat dissipator 12 with use of an adhesive agent, a screw, or the like. Since an outer circumferential surface of the reflector 30 is in contact with the inner circumferential surface of the heat dissipator 12, the mechanical strength is ensured to a certain degree even when the reflector 30 is made thinner. An opening is provided at a bottom portion of the reflector 30 so as to expose the light-emitting module 18. The light-emitting module 18 is disposed in the opening.

The reflector 30 is composed of a base 30a and a reflective film 30b. The base 30a is bowl-shaped, and has facets 30c formed thereon. The base 30a is made of a material on which the facets 30c can be easily formed. Examples of such a material include resin and glass. The reflective film 30b is made of a metal film or a dielectric multilayer film. The reflective film 30b may be made of not only a dielectric multilayer film but also a metal film, because light emitted from an LED device has a smaller infrared component than light emitted from a halogen lamp.

According to the stated structure, heat generated by the light-emitting module 18 is conducted to the heat dissipator 12 and thereby dissipated. This ensures high heat dissipation characteristics. Also, since the base 30a of the reflector 30 is made of either resin or glass, the facets 30c can be easily formed on the base 30a. Furthermore, since the heat dissipator 12 and the reflector 30 are separate members, a structure is possible where the heat dissipator 12 is commonly used while the reflector 30 is different depending on a light distribution pattern. This greatly reduces the manufacturing cost of the lighting apparatus.

#### Embodiment 3

FIG. 20 is a side view showing a structure of a lighting apparatus according to Embodiment 3 of the present invention. FIG. 21 is a sectional view showing the structure of the

**11**

lighting apparatus according to Embodiment 3 of the present invention. A lighting apparatus **3** according to Embodiment 3 is the same as the lighting apparatus **2** of Embodiment 2 in terms of the basic structure. The following describes differences between Embodiments 2 and 3.

In Embodiment 3, the bottom portion **12a** of the heat dissipator **12** is raised, and the circumferential wall portion **12b** has the windows **19**. The length of the cylindrical portion **11a** of the case **11**, in an axis direction thereof, is shortened by the amount of the bottom portion **12a** being raised.

A reflector **31** is fixed at the bottom portion **12a** of the heat dissipator **12**. The reflector **31** is fixed by, for example, screwing the reflector **31** into a groove provided in the bottom portion **12a** or adhering the reflector **31** to the bottom portion **12a** using an adhesive agent. The length of the reflector **31** in an axis direction thereof is shortened by the amount of the bottom portion **12a** of the heat dissipator **12** being raised. Also, since the reflector **31** is set up from the periphery of the light-emitting module **18**, an outer circumferential surface of the reflector **31** is spaced apart from the inner circumferential surface of the heat dissipator **12**. The base **31a** of the reflector **31** is made of a material that is translucent and on which facets can be easily formed. Examples of such a material include translucent resin and glass. A reflective film **31b** of the reflector **31** is made of a dielectric multilayer film that transmits part of light emitted from the light-emitting module **18** (e.g., part of visible light).

The front cover **13** is provided with a sub-reflector **32** for reflecting direct light from the light-emitting module **18** toward the reflector **31**. The "direct light" refers to light emitted forward (i.e., toward the opening of the heat dissipator **12**) without being reflected by the reflector **31**.

According to the stated structure, the bottom portion **12a** of the heat dissipator **12** is raised, thereby reducing the size of the entirety of the lighting apparatus. Furthermore, by providing the sub-reflector **32**, the length of the reflector **31** in the axis direction thereof is shortened. As a result, the size of the entirety of the lighting apparatus is further reduced.

Also, the reflective film **31b** is made of the dielectric multilayer film that transmits part of emitted light, and the circumferential wall portion **12b** of the heat dissipator **12** has the windows **19**. In this way, light from the light-emitting module **18** is emitted outwardly from the opening of the heat dissipator **12**, and also leaked from the circumferential wall portion **12b** of the heat dissipator **12**. This improves the "perceived radiance" of the lighting apparatus **3**.

Also, since the reflector **31** is spaced apart from the inner circumferential surface of the heat dissipator **12**, the shape of the reflector **31** does not need to match the shape of the heat dissipator **12**, and can be designed arbitrarily according to the light distribution pattern.

Note that the modifications (1) to (16) of Embodiment 1 are equally applicable to the heat dissipator **12**, the light-emitting module **18**, and the windows **19** according to Embodiments 2 and 3.

## INDUSTRIAL APPLICABILITY

The present invention is applicable to, for example, a lighting apparatus that substitutes for a reflector halogen lamp.

## REFERENCE SIGNS LIST

**1, 2, and 3** lighting apparatus  
**11** case

**12**

**11a** cylindrical portion  
**11b** protrusion  
**12** heat dissipator  
**12a** bottom portion  
**12b** circumferential wall portion  
**12c** circumferential area  
**12d** circumferential area  
**12e** inner circumferential wall portion  
**12f** outer circumferential wall portion  
**13** front cover  
**14** metal fitting  
**15** shell  
**16** eyelet  
**17** lighting circuit  
**18** light-emitting module  
**18a** metal substrate  
**18b** LED device  
**18c** silicone resin member  
**18d** lens  
**19** window  
**19c** central axis  
**20** feed pin  
**21** circumferential cover  
**22** molded product  
**23** front cover  
**24** lens  
**24a** protrusion  
**25** circumferential cover  
**25a** projection  
**26** adhesive agent  
**27 and 28** light guiding member  
**29** shutter  
**30 and 31** reflector  
**30a and 31a** base  
**30b and 31b** reflective film  
**30c and 31c** facet  
**32** sub-reflector

The invention claimed is:

**[1.** A lighting apparatus comprising:

a heat dissipator that is in one of a bottomed cylindrical shape and a bowl shape, and that has a bottom portion, a circumferential wall portion, and an upper opening; and

a light-emitting device that is provided in an inside of the heat dissipator at the bottom portion and is operable to emit light through the upper opening and towards the circumferential wall portion, wherein

the circumferential wall portion has one or more windows for leaking a portion of the emitted light to illuminate an outside of the heat dissipator,

the circumferential wall portion has an inner surface and an outer surface,

the light-emitting device is provided in a space defined by the inner surface of the circumferential wall, and

the windows are through-holes that pass through the inner surface and the outer surface of the circumferential wall portion, and each throughhole is closed off by a translucent member that transmits the portion of the emitted light.]

**[2.** The lighting apparatus of claim **1**, wherein the windows are provided at equal intervals in a circumferential direction of the circumferential wall portion.]

**[3.** The lighting apparatus of claim **1**, wherein a size of each window is such that the closer the window is to the upper opening of the heat dissipator, the larger the size of the window is.]

## 13

- [4. The lighting apparatus of claim 1, wherein each window is provided in a part of the circumferential wall portion located between first and second virtual planes, the first virtual plane including the opening of the heat dissipater, the second virtual plane passing through the light-emitting device and being perpendicular to a central axis of the heat dissipater that is in one of the bottomed cylindrical shape and the bowl shape.]
- [5. The lighting apparatus of claim 1, wherein the translucent member is colorless.]
- [6. The lighting apparatus of claim 1, wherein the translucent member is a color filter.]
- [7. The lighting apparatus of claim 1, wherein the heat dissipater also serves as a reflector.]
- [8. The lighting apparatus of claim 1, wherein the heat dissipater is made of one of a metal material, a non-translucent ceramic material, and a non-translucent resin material.]
- [9. The lighting apparatus of claim 8 further comprising a heat-conductive member that is provided between the light-emitting device and the bottom portion of the heat dissipater.]
- [10. The lighting apparatus of claim 1 further comprising: a case fixed to an outer surface of the bottom portion of the heat dissipater; and a lighting circuit housed in the case, the case having a metal shell and a metal eyelet that serve as electrical feed terminals for mounting in an external power source.]
- [11. A lighting apparatus to replace a halogen lamp comprising:  
a heat dissipater that has a bowl shape with a flat bottom portion, an annular circumferential wall portion extending upward from the flat bottom portion, and an upper opening; and  
a light-emitting LED device is provided inside the heat dissipater on the bottom portion and is operable to emit light through the opening and towards the circumferential wall portion, wherein  
the annular circumferential wall portion has a plurality of spaced windows for emitting a portion of the emitted light through and around the circumferential wall portion to illuminate an outside of the heat dissipater to simulate a surrounding light of halogen lamps,  
the annular circumferential wall portion has a reflector inner surface that reflects light through the upper opening and an outer surface,  
the light-emitting LED device is provided in a space defined by the reflector inner surface of the annular circumferential wall, and  
the plurality of spaced windows are through-holes that pass through the inner surface and the outer surface of the annular circumferential wall portion to simulate the surrounding light of halogen lamps.]
- [12. The lighting apparatus of claim 11 further comprising:  
a case fixed to an outer surface of the bottom portion of the heat dissipater;

## 14

- a lighting circuit housed in the case, the case having a metal shell and a metal eyelet that serves as electrical feed terminals for mounting in an external power source; and  
each throughhole is closed off by a transparent member that transmits the portion of the emitted light to simulate the surrounding light of halogen lamps.]
13. *A lighting apparatus, comprising:  
a heat dissipater including a circumferential wall portion;  
an LED provided inside the heat dissipater, the LED being operable to emit light towards the circumferential wall portion, and  
a threaded shell base having an eyelet as one of outermost members of the lighting apparatus,  
wherein the heat dissipater is one of the outermost members of the lighting apparatus,  
the circumferential wall portion has a plurality of windows,  
the circumferential wall portion has a reflector inner surface and an outer surface,  
the plurality of windows are through-holes that pass through the inner surface and the outer surface of the circumferential wall portion, and  
the LED is located on an extended line of the central axis of each of the plurality of windows.*
14. *The lighting apparatus of claim 13,  
wherein the plurality of windows are provided along a circumferential direction of the circumferential wall portion.*
15. *The lighting apparatus of claim 14,  
wherein each of the plurality of windows is a lateral slit.*
16. *The lighting apparatus of claim 13,  
wherein the plurality of windows include a plurality of rows of through-holes.*
17. *The lighting apparatus of claim 16,  
wherein the plurality of rows of through-holes include a first row of openings aligned in a first plane and a second row of through-holes aligned in a second plane parallel to the first plane.*
18. *The lighting apparatus of claim 16,  
wherein the plurality of rows of through-holes include first and second annular rows spaced from each other along the circumferential wall.*
19. *The lighting apparatus of claim 13, further comprising:  
a lighting circuit that supplies power to the LED, the lighting circuit being provided intermediate of the LED and a base of the lighting apparatus.*
20. *The lighting apparatus of claim 13,  
wherein the threaded shell base is electrically connected to a lighting circuit, the threaded shell base being configured to receive power from a power source.*
21. *The lighting apparatus of claim 13,  
wherein the plurality of windows are provided on a threaded shell base side of the circumferential wall portion.*