



US00RE48756E

(19) **United States**
(12) **Reissued Patent**
Cutsforth

(10) **Patent Number:** **US RE48,756 E**
(45) **Date of Reissued Patent:** **Sep. 28, 2021**

(54) **SYSTEM AND METHOD FOR MONITORING THE STATUS OF ONE OR MORE COMPONENTS OF AN ELECTRICAL MACHINE**

FOREIGN PATENT DOCUMENTS

CN 1395343 A 2/2003
CN 101369706 A 2/2009

(Continued)

(71) Applicant: **CUTSFORTH, INC.**, Cohasset, MN (US)

(72) Inventor: **Robert S. Cutsforth**, Bellingham, WA (US)

(73) Assignee: **CUTSFORTH, INC.**, Cohasset, MN (US)

(21) Appl. No.: **16/393,079**

(22) Filed: **Apr. 24, 2019**

Related U.S. Patent Documents

Reissue of:

(64) Patent No.: **9,640,930**
Issued: **May 2, 2017**
Appl. No.: **14/982,480**
Filed: **Dec. 29, 2015**

U.S. Applications:

(63) Continuation of application No. 13/802,969, filed on Mar. 14, 2013, now Pat. No. 9,252,643.

(51) **Int. Cl.**
G08B 21/00 (2006.01)
H01R 39/58 (2006.01)
(Continued)

(52) **U.S. Cl.**
CPC **H01R 39/58** (2013.01); **H01R 39/381** (2013.01); **H02K 11/20** (2016.01)

(58) **Field of Classification Search**
CPC H01R 39/58; H01R 39/381; H02K 11/20
See application file for complete search history.

(56) **References Cited**

U.S. PATENT DOCUMENTS

3,146,365 A * 8/1964 Millar H01R 39/385
310/246
3,599,165 A * 8/1971 Wendell H01R 35/025
439/164

(Continued)

OTHER PUBLICATIONS

Wurfel et al. "Monitoring and diagnostics of the rotor slip ring system of three phase current induction generators" University of Technology Chemnitz, D-09126 Chemnitz, Germany.

(Continued)

Primary Examiner — Ovidio Escalante

(74) *Attorney, Agent, or Firm* — Seager, Tufte & Wickhem LLP

(57) **ABSTRACT**

A monitoring apparatus configured for monitoring a carbon brush of a brush holder assembly of an electrical machine. The monitoring apparatus may include a flexible sensor and a signal processing circuit for processing a signal received from the flexible sensor. The flexible sensor may have an electrical resistance that varies based on a radius of curvature of the flexible sensor, wherein the radius of curvature of the flexible sensor may be associated with a deflection of a spring providing a force to engage the carbon brush with a rotating component of the electrical machine. The signal processing circuit may be coupled to the sensor and may be configured to determine a measure of a wear state of the carbon brush using information about the variable resistance of the flexible sensor.

49 Claims, 12 Drawing Sheets

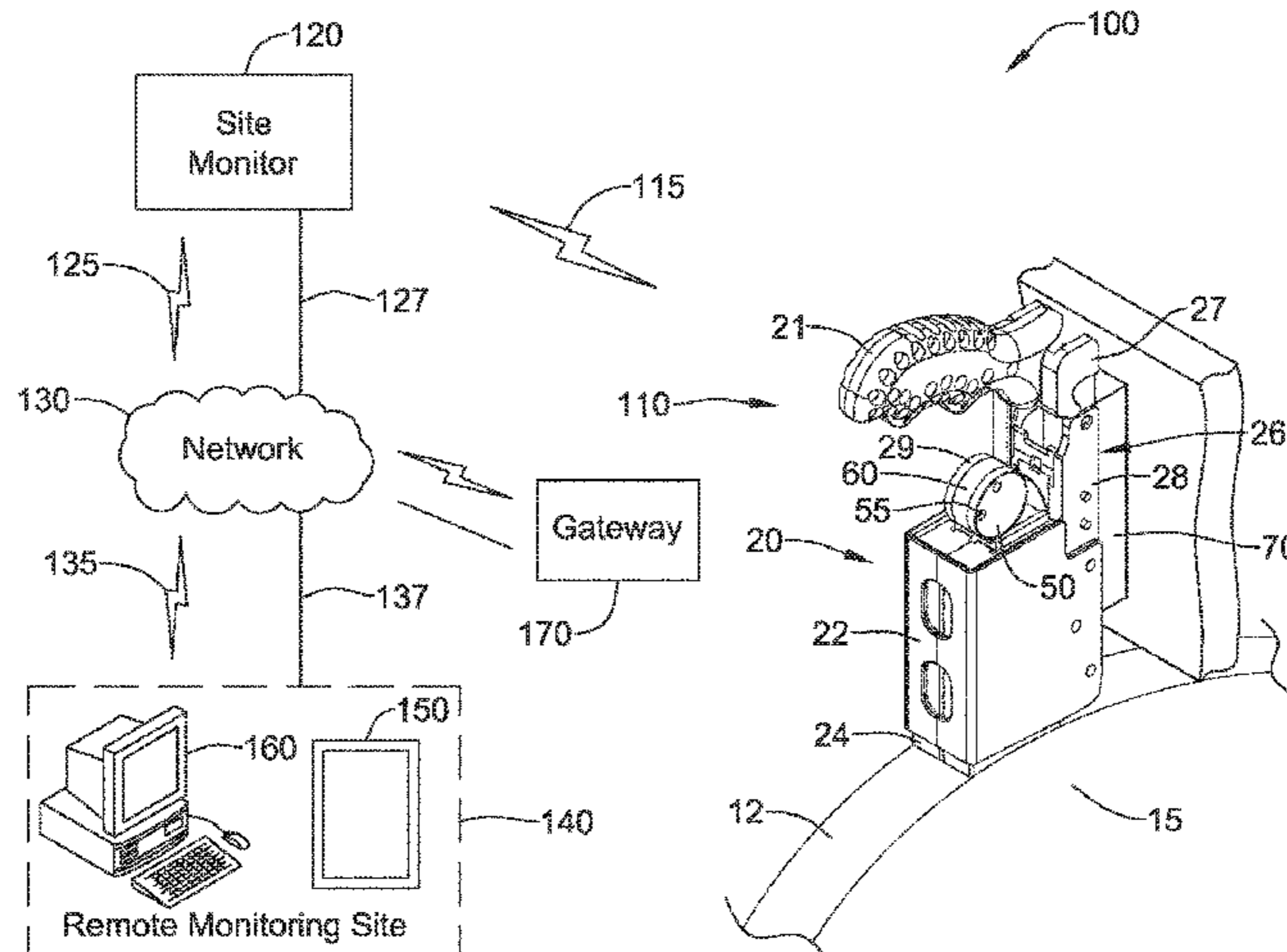

US RE48,756 E

(51)	Int. Cl. <i>H02K 11/20</i> (2016.01) <i>H01R 39/38</i> (2006.01)	8,047,083 B2 11/2011 Puzio et al. 8,054,190 B2 11/2011 Hobelsberger 8,618,943 B2 12/2013 Cutsforth et al. 9,252,643 B2* 2/2016 Cutsforth H01R 39/58 2003/0011388 A1* 1/2003 Klaar H02K 11/25 324/723
(56)	References Cited	2007/0273165 A1 11/2007 Beck et al. 2008/0291273 A1 11/2008 Cutsforth et al. 2012/0248929 A1 10/2012 Fish et al. 2014/0009142 A1* 1/2014 Cauwenberghs H02K 11/20 324/207.11
	U.S. PATENT DOCUMENTS	
	3,634,710 A * 1/1972 Woda H01R 39/40 310/239 4,636,778 A 1/1987 Corkran et al. 4,739,208 A * 4/1988 Kimberlin H01R 39/58 200/61.4 4,743,787 A 5/1988 Bunner et al. 5,157,372 A 10/1992 Langford 5,256,925 A 10/1993 Cutsforth 5,397,952 A 3/1995 Decker et al. 5,463,264 A 10/1995 Koenitzer 5,621,262 A 4/1997 Han 5,731,650 A * 3/1998 Scheucher H01R 39/58 310/242 5,753,992 A 5/1998 Avitable et al. 5,870,026 A 2/1999 Challenger 5,892,303 A * 4/1999 Wayman G03G 15/0818 307/147 6,359,690 B1 3/2002 Discenzo et al. G01D 5/268 356/450 6,552,467 B1 4/2003 Suriano et al. 6,731,042 B1 5/2004 Bank et al. 6,933,650 B2 8/2005 Wang H01R 39/58 310/239 6,960,922 B2 11/2005 Klaar 7,034,430 B2 4/2006 Cutsforth et al. 7,045,929 B2 5/2006 Yu 7,248,142 B2 7/2007 Beck et al. 7,277,004 B2 10/2007 Beck et al. 7,705,744 B2 4/2010 Cutsforth 7,880,362 B2 2/2011 Cutsforth et al.	FOREIGN PATENT DOCUMENTS
		DE 19755232 A1 6/1999 DE 102012102726 A1 10/2012 EP 1441422 A2 7/2004 EP 1801938 A2 6/2007 SU 1179464 A1 9/1985 WO 2012119832 A1 9/2012 WO 2012123402 A1 9/2012
		OTHER PUBLICATIONS
		Authorized Officer Joël Basilé, International Search Report and Written Opinion for PCT/US2014/022526 dated Jun. 16, 2014, 12 pages. Flexpoint Sensor Systems, Inc. "Bend Sensor Technology Elec- tronic Interface Design Guide," pp. 1-14, 1997. Flexpoint Sensor Systems, Inc. "Then or Now? The Thin, flexible Bend Sensor from Flexpoint offers limitless possibilities," 1999. Flexpoint Sensor Systems "Bend Sensor Technology Mechanical Application Design Guide," 10 pgs, 1997. Japanese Laid-Open Utility Model Publication No. 2-110975, Sep. 5, 1990, 15 pages.
		* cited by examiner

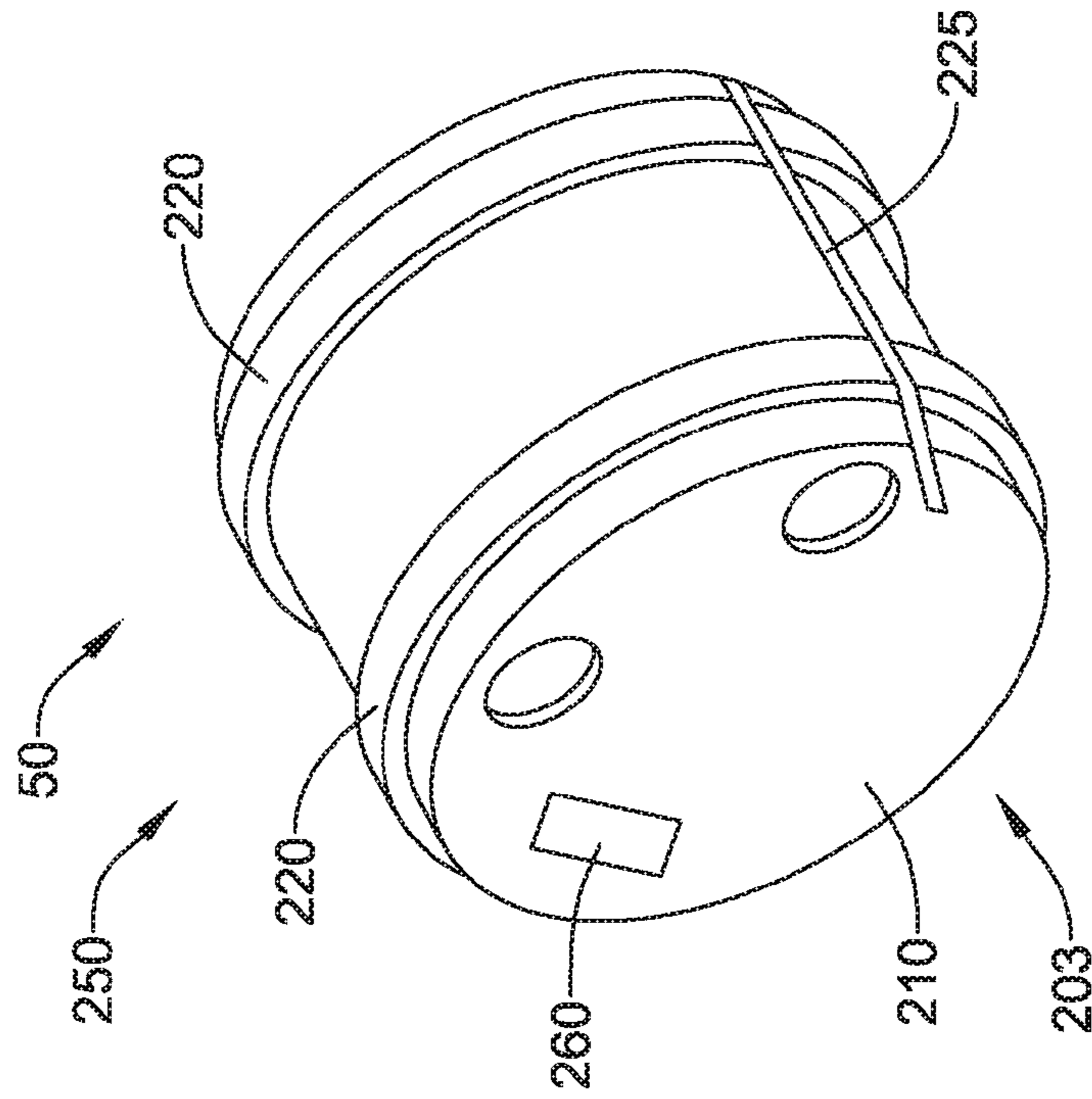

Figure 2A

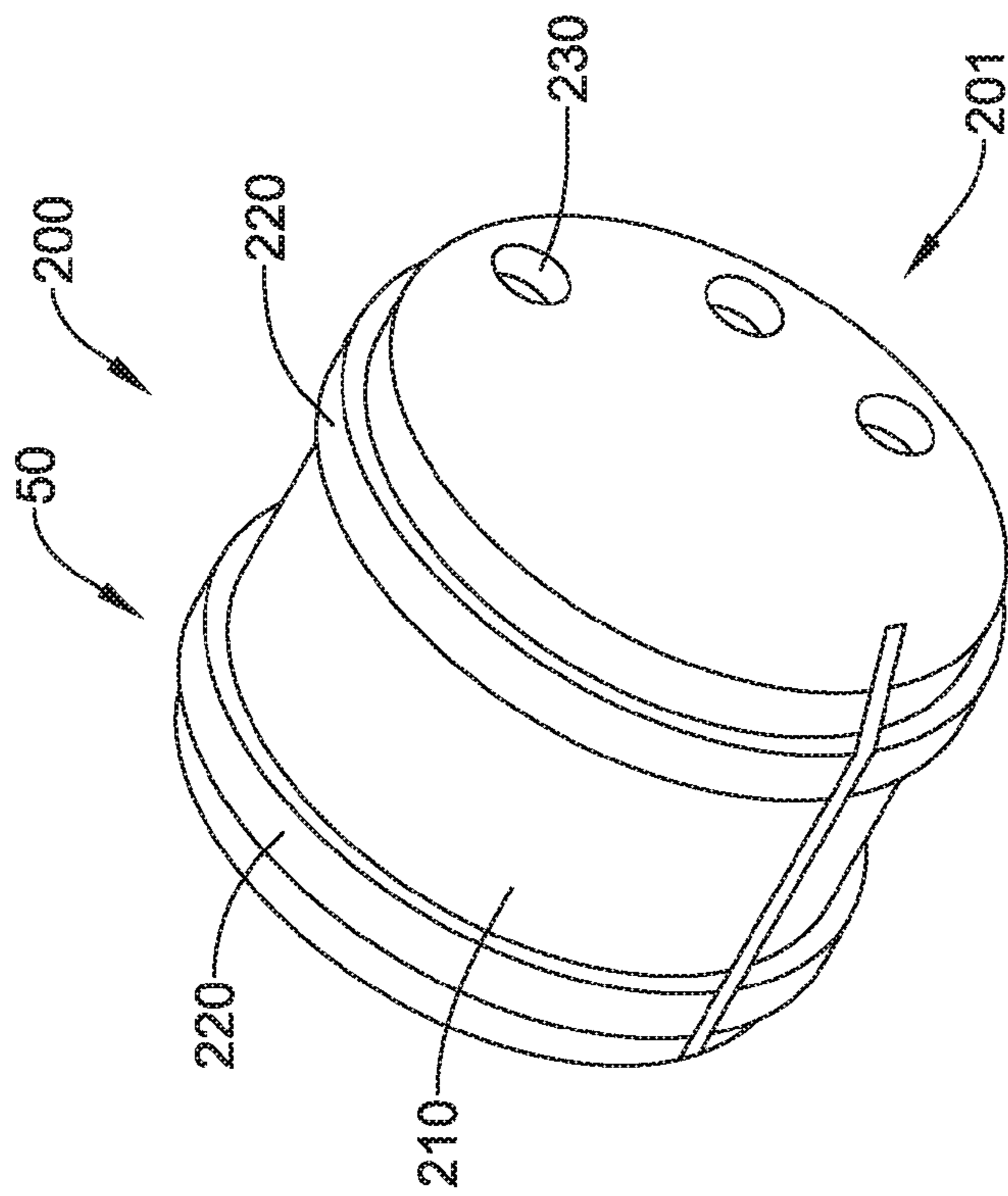

Figure 2B

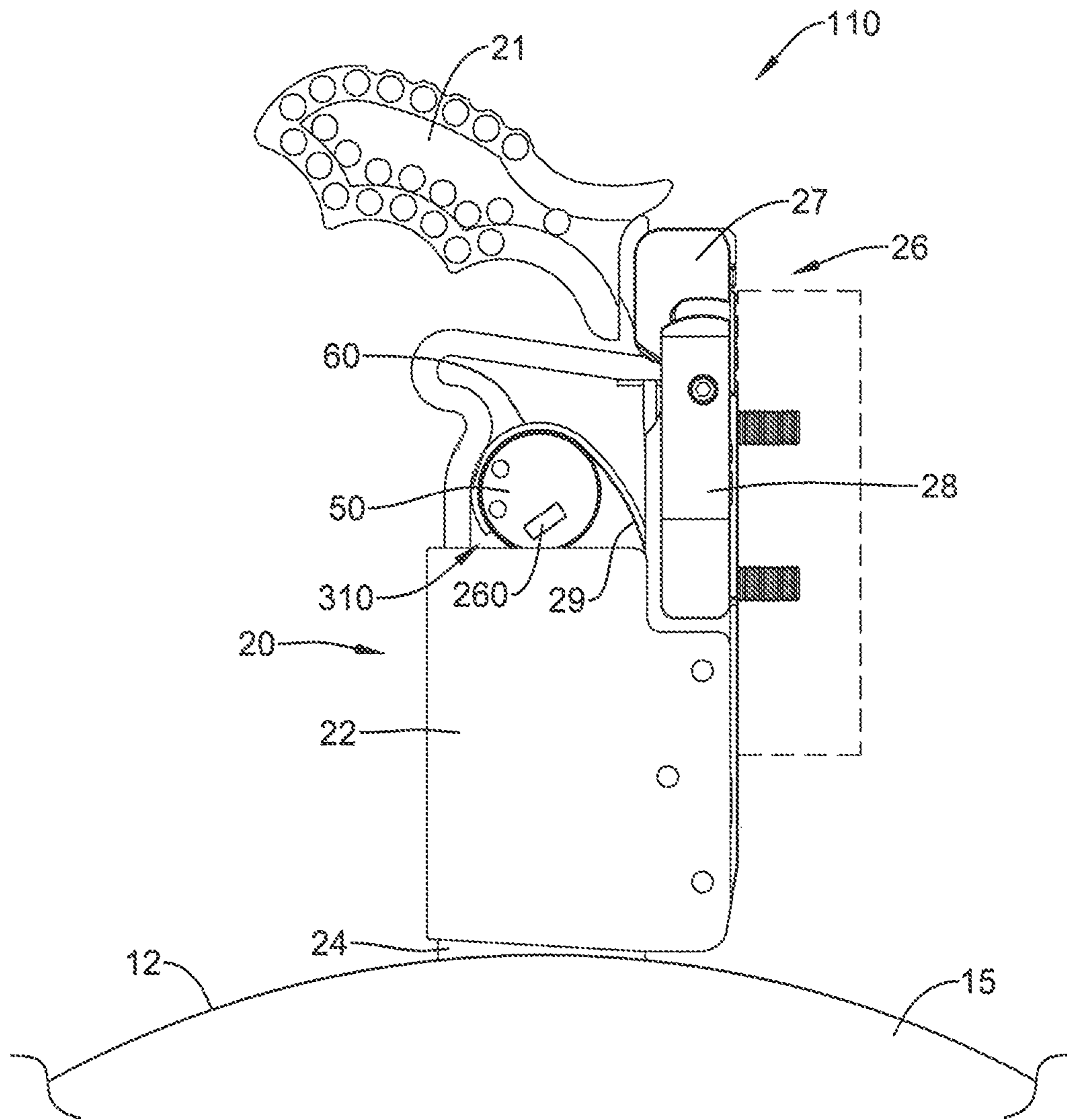

Figure 3

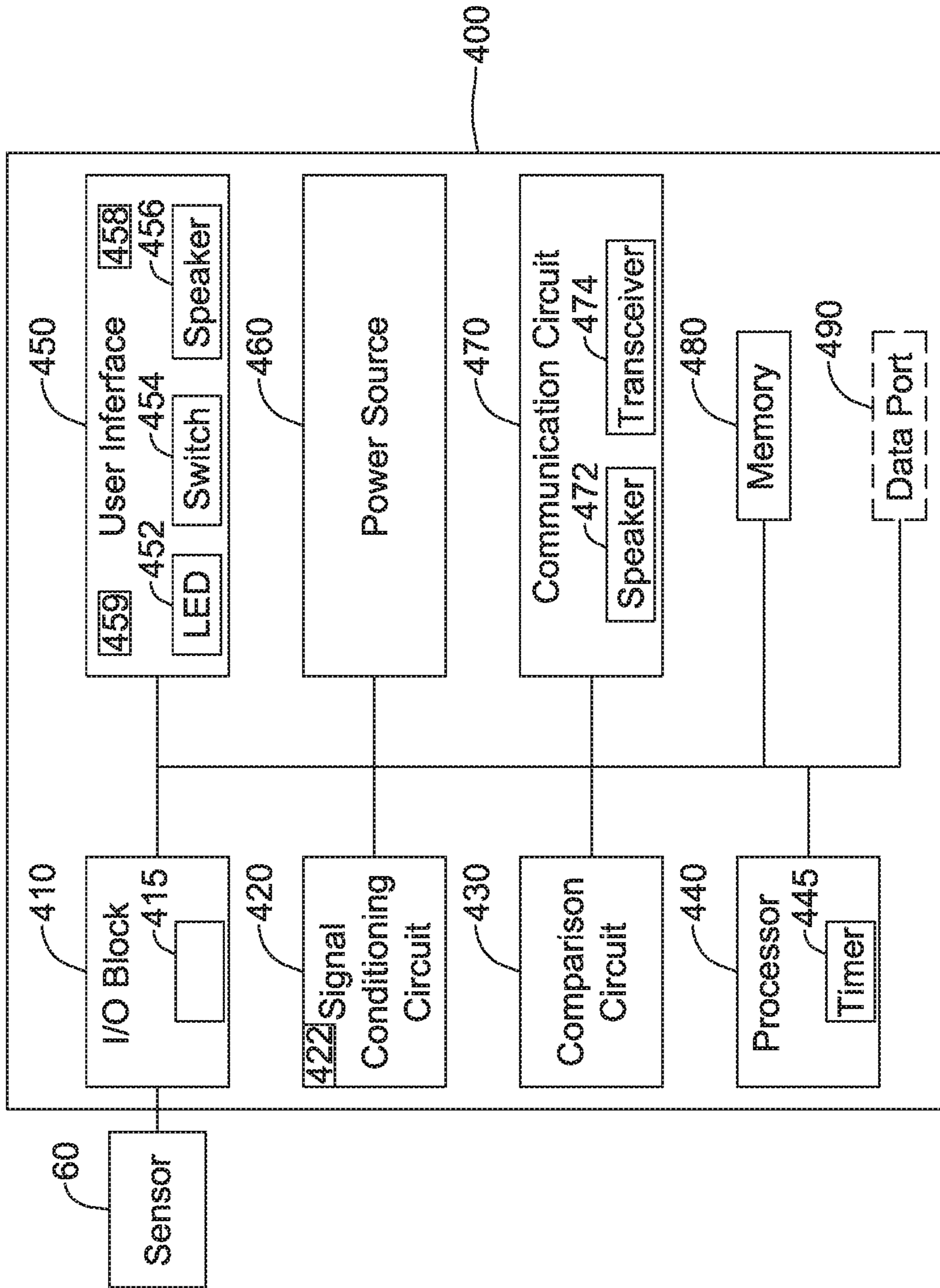

Figure 4

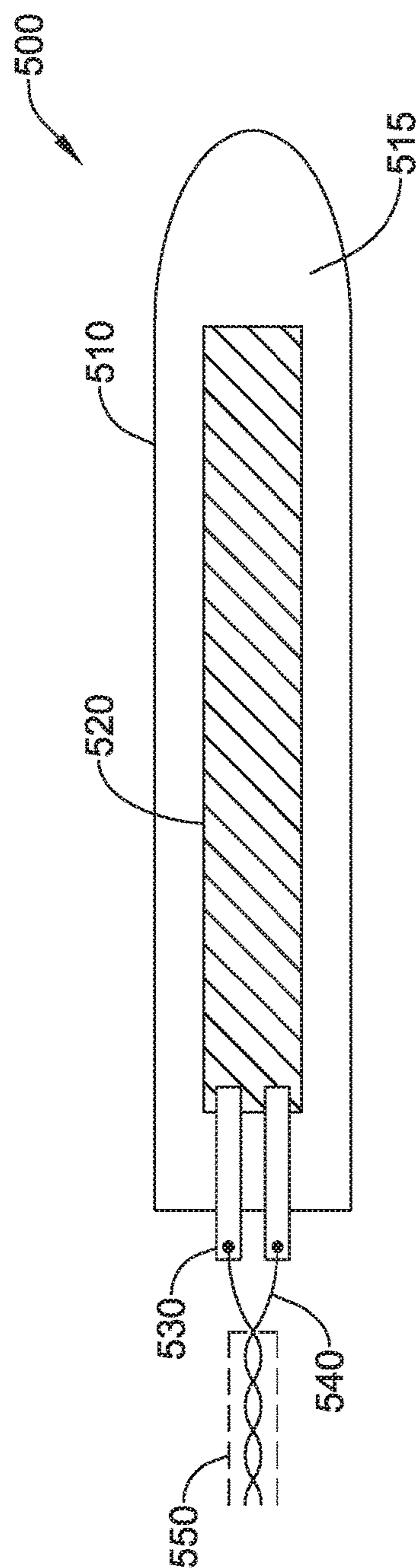

Figure 5A

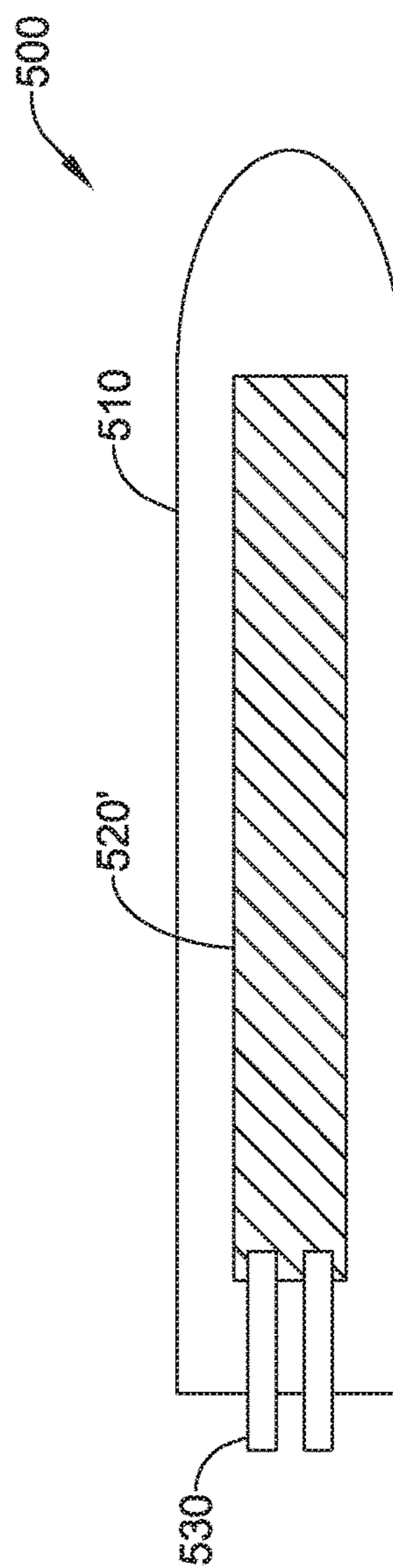

Figure 5B

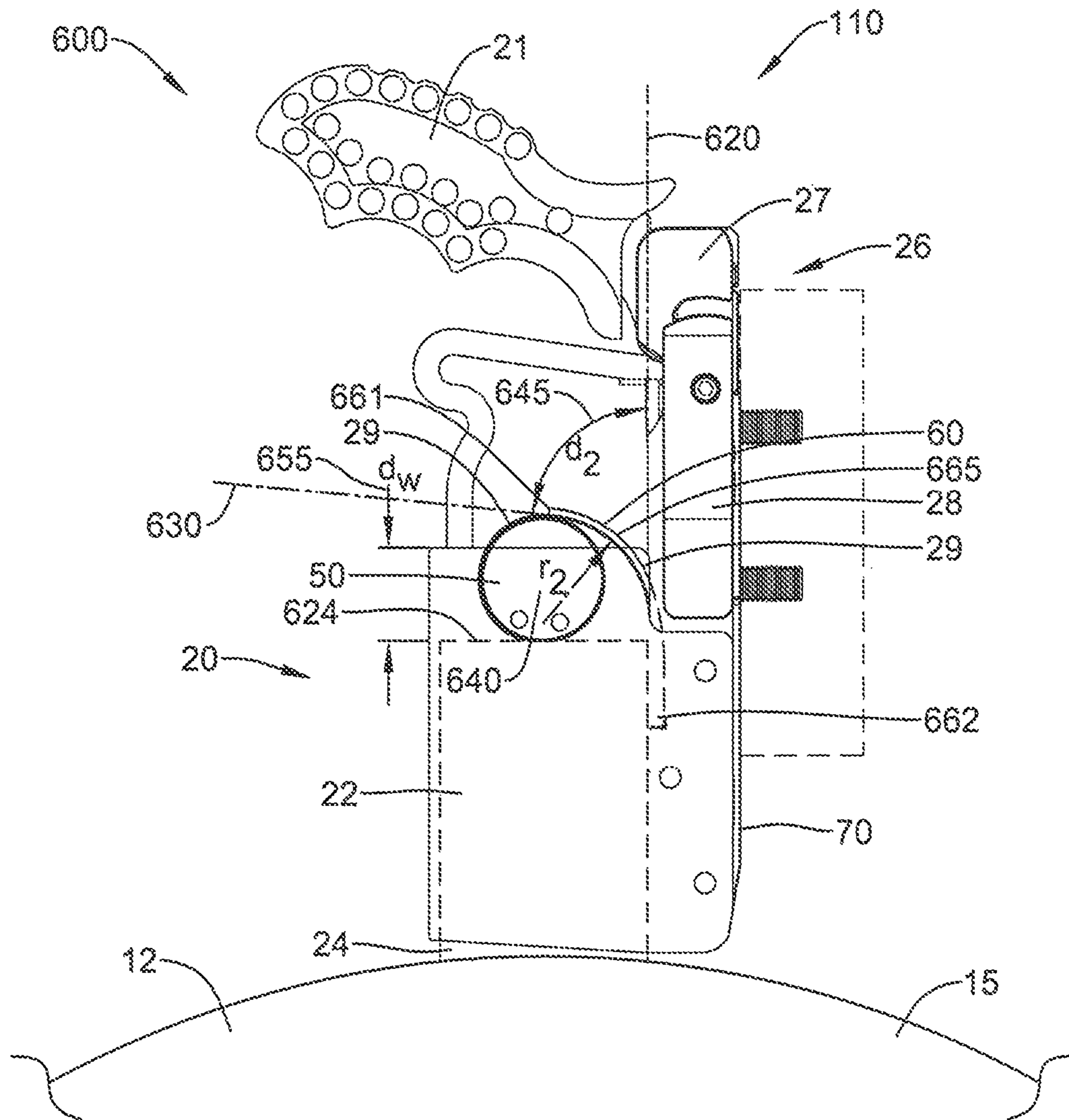

Figure 6B

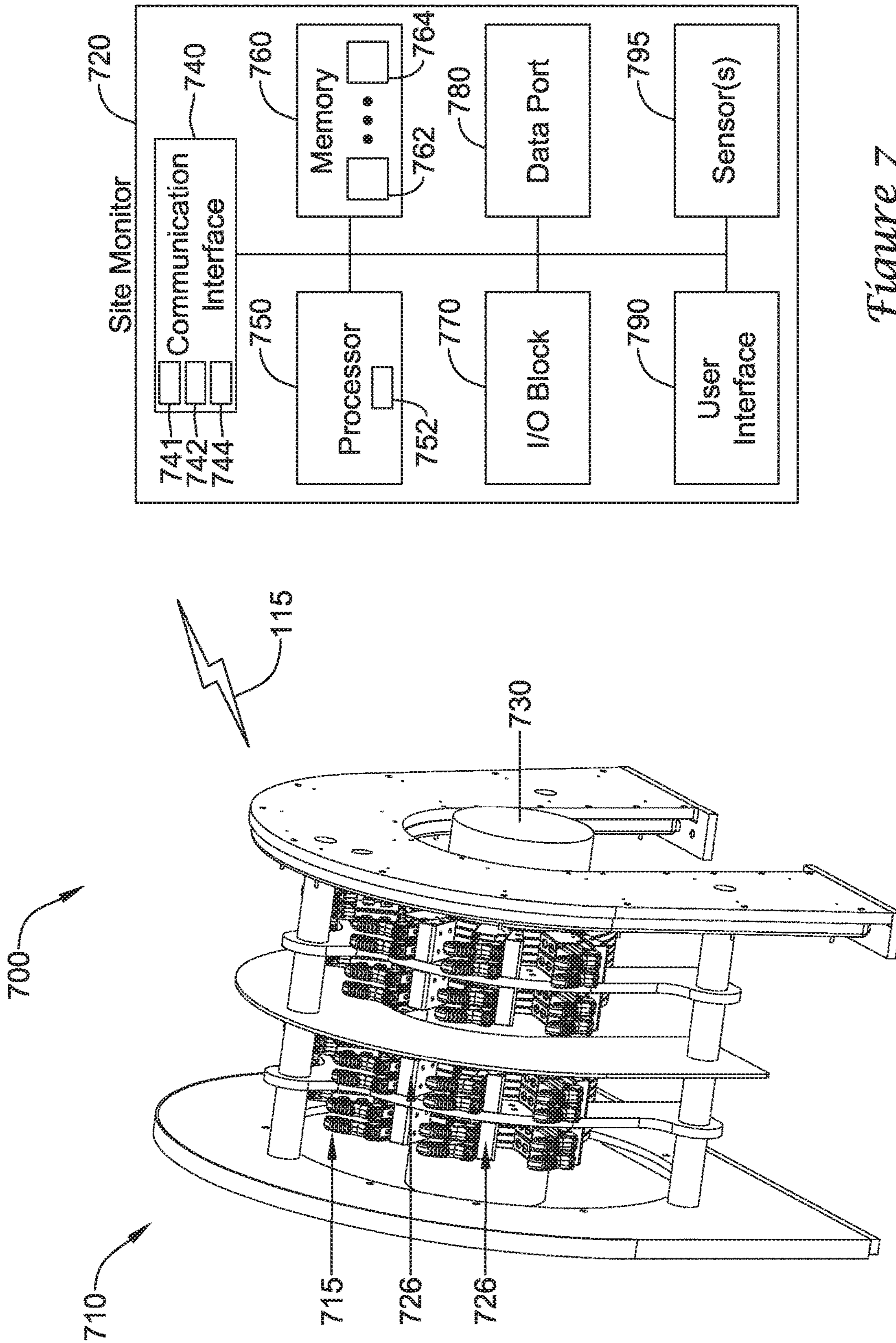

Figure 7

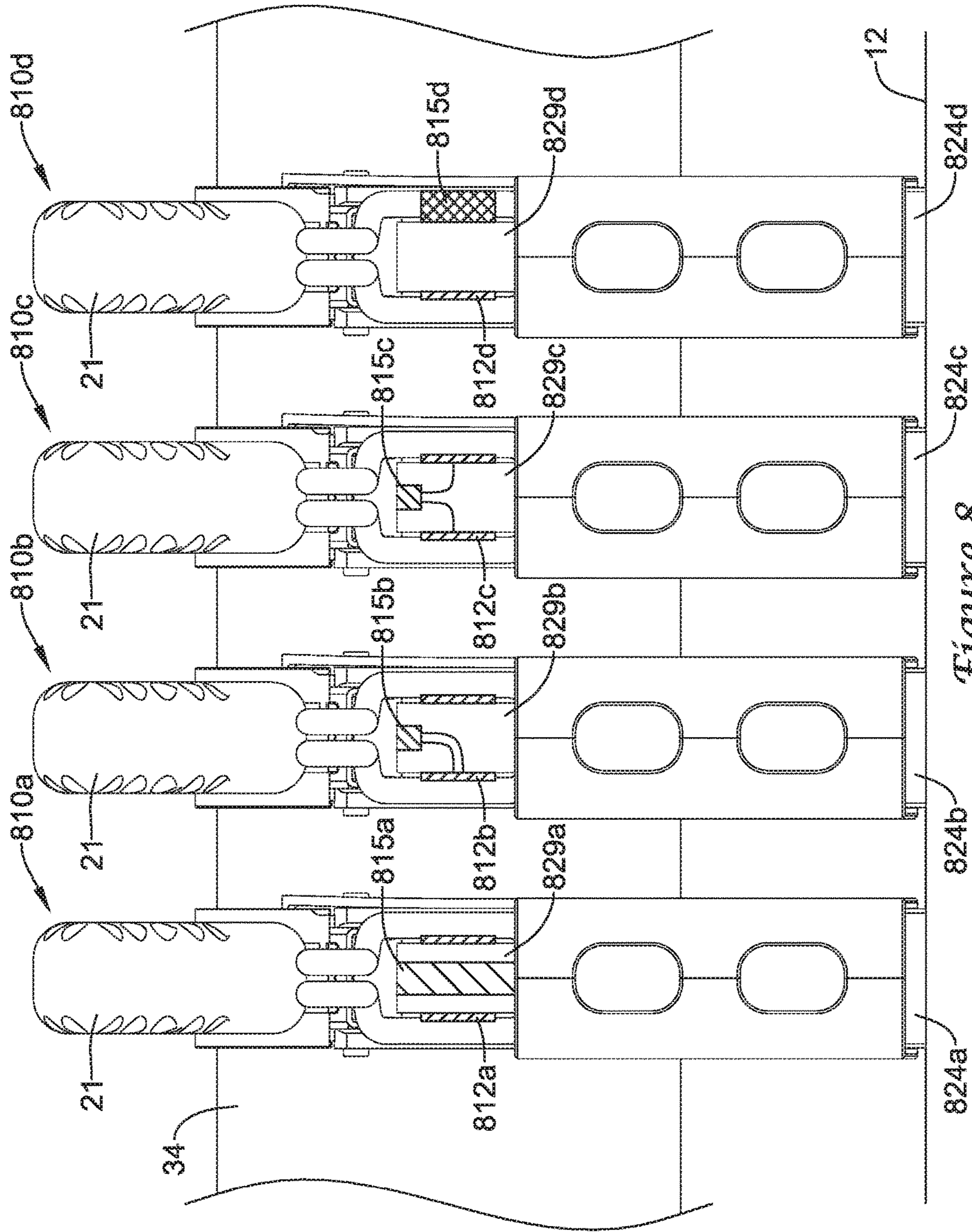

Figure 8

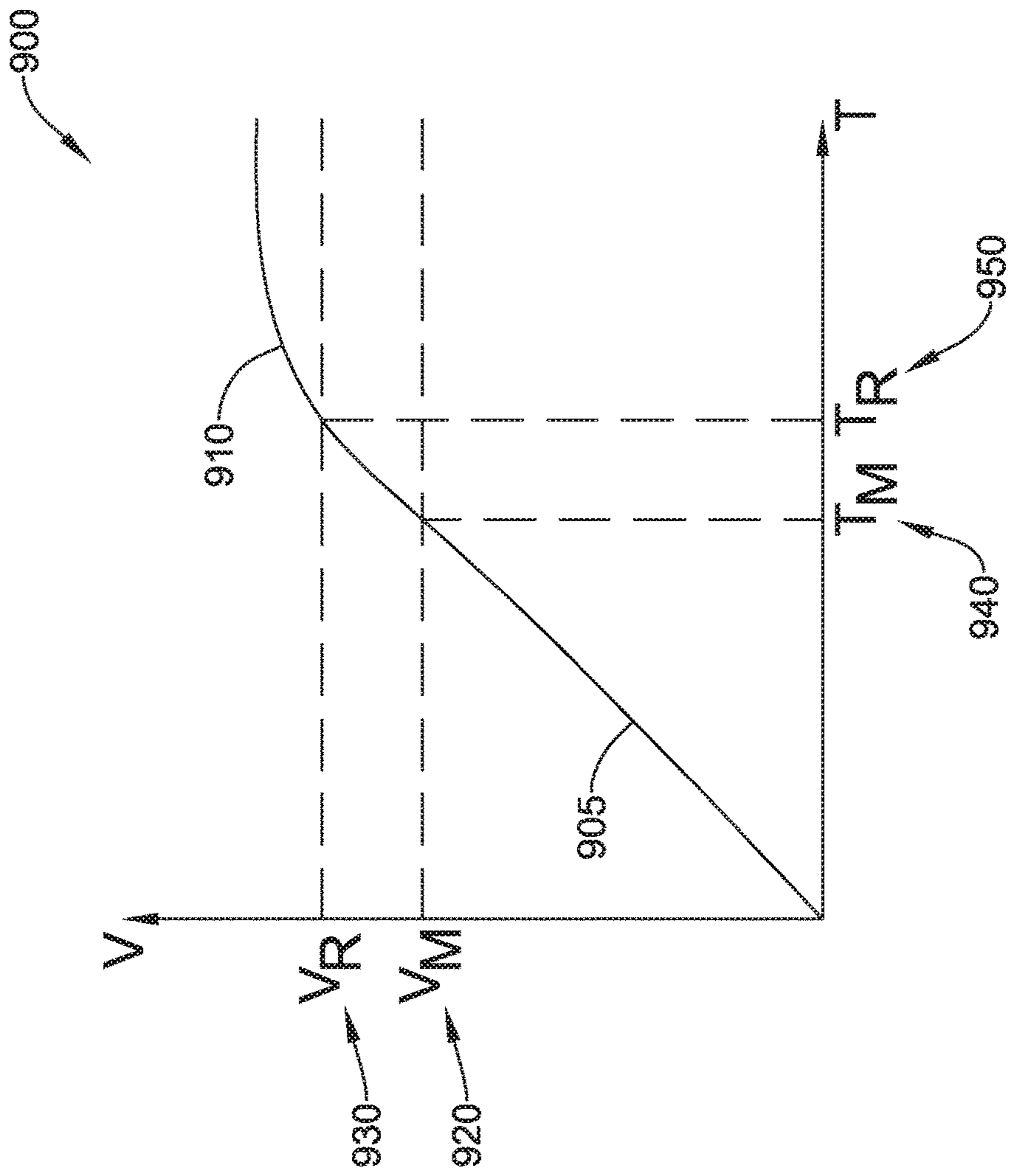

Figure 9

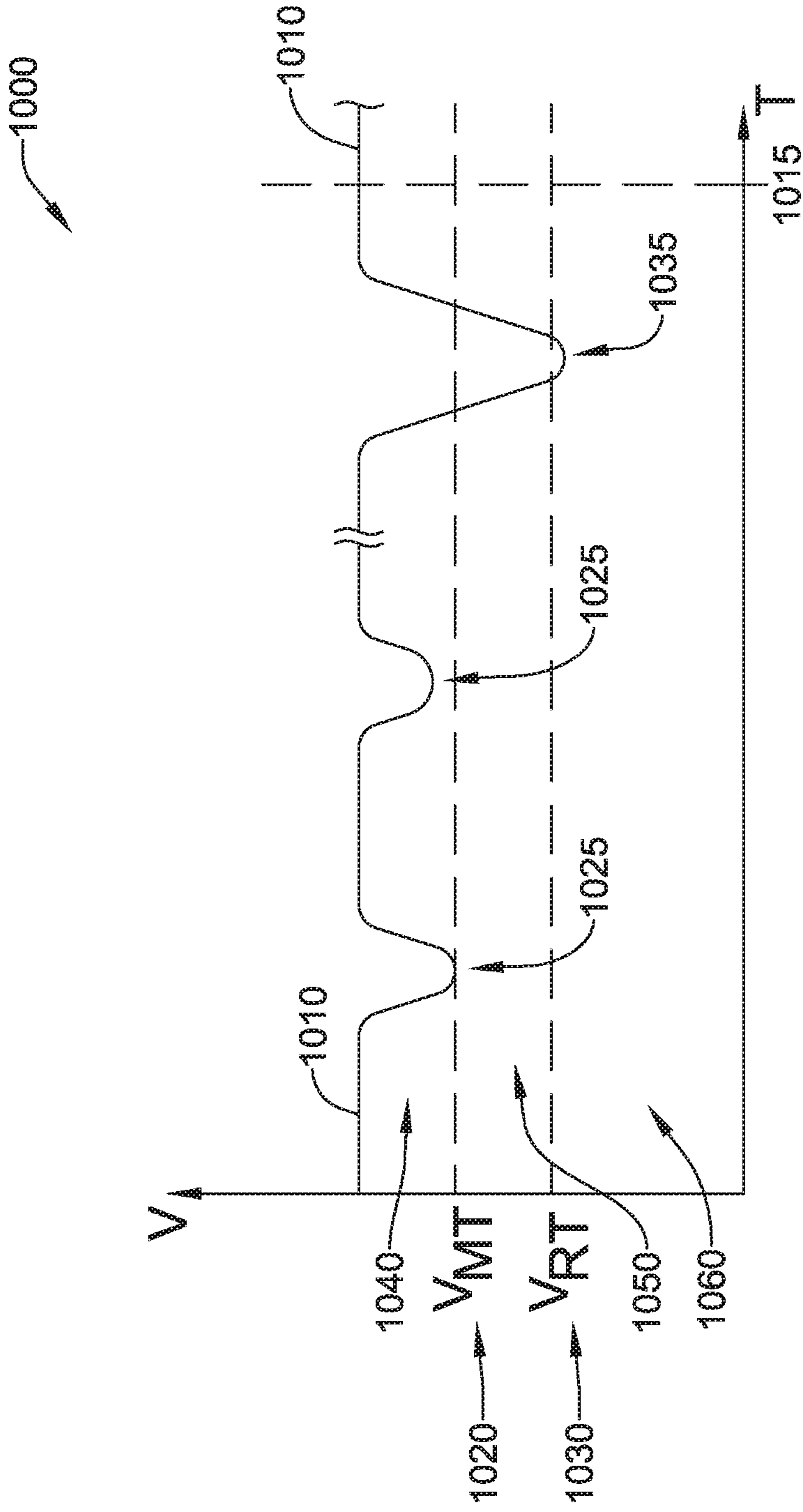

Figure 10

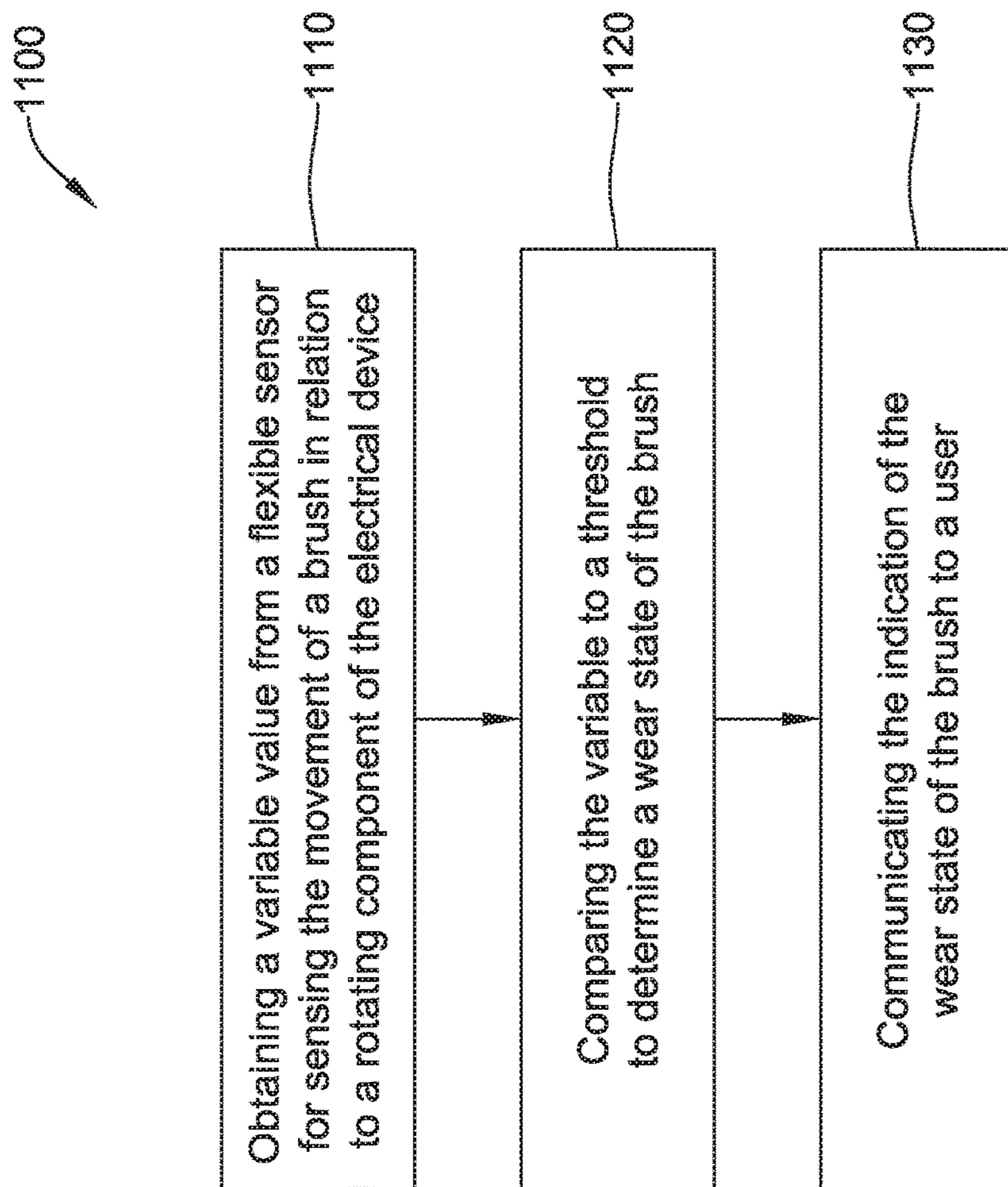

Figure 11

**SYSTEM AND METHOD FOR MONITORING
THE STATUS OF ONE OR MORE
COMPONENTS OF AN ELECTRICAL
MACHINE**

Matter enclosed in heavy brackets [] appears in the original patent but forms no part of this reissue specification; matter printed in italics indicates the additions made by reissue; a claim printed with strikethrough indicates that the claim was canceled, disclaimed, or held invalid by a prior post-patent action or proceeding.

CROSS-REFERENCE TO RELATED
APPLICATION

The present application is a continuation application of U.S. patent application Ser. No. 13/802,969, filed Mar. 14, 2013, the complete disclosure of which is herein incorporated by reference.

TECHNICAL FIELD

The disclosure generally relates to monitoring systems for monitoring brushes and brush holder assemblies that may be used in electrical devices and/or slip ring assemblies. More specifically, the disclosure relates to monitoring apparatus, assemblies, systems and methods of monitoring the wear of a brush in a brush holder assembly and/or the condition of a slip ring of an electrical device using a flex sensor.

BACKGROUND

A purpose of a brush in an electrical device is to pass electrical current from a stationary contact to a moving contact surface, or vice versa. Brushes and brush holders may be used in electrical devices such as electrical generators, electrical motors, and/or slip ring assemblies, or sliding connection applications, for example, slip ring assemblies on a rotating machine such as a rotating crane or a linear sliding connection on a monorail. Brushes in many electrical devices are blocks or other structures made of conductive material, such as graphite, carbon graphite, electrographite, metal graphite, or the like, that are adapted for contact with a conductive surface or surfaces to pass electrical current. Electrically conductive leads or shunts extend from the brush to provide an electrical pathway to and/or from the brush from another conductive member.

In some designs, a brush box type brush holder, or other type of brush holder, may be used to support a brush in contact with a moving contact surface of an electrical device during operation. The brush and brush box may be designed such that the brush can slide within the brush box to provide for continuing contact between the brush and the moving contact surface contacted by the brush. During operation an anomalous and/or threshold condition may occur, which may be indicative that one or more components of the electrical device may need to be replaced, one or more components of the electrical device may require inspection or attention, and/or maintenance may need to be performed. For example, an anomalous and/or threshold condition may indicate that one or more of a brush, brush holder, spring, shunt, commutator, collector ring, and/or other component may need to be replaced, one or more of a brush, brush holder, spring, shunt, commutator, collector ring, and/or other component may need to be inspected, and/or maintenance may need to be performed. It would be advantageous

to monitor one or more components of an electrical device in order to observe the occurrence of an anomalous and/or threshold condition. Furthermore, it would be advantageous to alert an operator and/or technician of the occurrence of an anomalous and/or threshold condition and/or schedule technician intervention.

SUMMARY

The disclosure is directed to monitoring apparatus, assemblies, systems and methods of monitoring the wear of a brush in a brush holder assembly and/or the condition of a slip ring of an electrical device using a flex sensor. Accordingly, one illustrative embodiment is a monitoring apparatus configured for monitoring a carbon brush of a brush holder assembly of an electrical machine. The monitoring apparatus may include a flexible sensor and a signal processing circuit for processing a signal received from the flexible sensor. The flexible sensor may have an electrical resistance that varies based on a radius of curvature of the flexible sensor, wherein the radius of curvature of the flexible sensor may be associated with a deflection of a spring providing a force to engage the carbon brush with a rotating component of the electrical machine. The signal processing circuit may be coupled to the sensor and may be configured to determine a measure of a wear state of the carbon brush using information about the variable resistance of the flexible sensor.

Another illustrative embodiment is a system for monitoring a wear state of one or more carbon brushes associated with an electrical machine and/or a wear state of a rotating component of the electrical machine. The system may include one or more brush holder assemblies associated with the electrical machine and a site monitor for receiving wear state information from the one or more brush holder assemblies. Each of the brush holder assemblies may include a carbon brush, a spring adjacent to the carbon brush, a flexible sensor positioned adjacent to the spring and a wear state monitor coupled to the flexible sensor. The spring may be configured to provide a force to the carbon brush such that the carbon brush engages a rotating component of the electrical machine. The flexible sensor may have an electrical resistance that varies based on a radius of curvature of the flexible sensor. The radius of curvature may be representative of a physical position and/or movement of the carbon brush. By monitoring the physical position, and/or the movement of the carbon brush, such as by monitoring a measure (e.g., a resistance, a voltage, a current, etc.) associated with the radius of curvature of the bend sensor, a wear state of the carbon brush and/or a wear state of the rotating component of the electrical machine may be determined. The wear state monitor may be configured for determining a measure of a wear state of the carbon brush using the variable resistance of the flexible sensor. The site monitor may be communicatively coupled with the wear state monitor of the one or more brush assemblies for receiving wear state information about the carbon brushes of the one or more brush assemblies and communicating the wear state of the one or more carbon brushes to a user.

An illustrative method for monitoring a wear state of one or more components of an electrical device may include obtaining a variable resistance value from a flexible resistor for sensing the movement of a carbon brush in relation to a rotating component of the electrical device, comparing the variable resistance value to a threshold value to determine a wear state of the carbon brush, and communicating an indication of the wear state of the carbon brush to a user.

Another illustrative embodiment may be a brush holder assembly having an integral sensor for monitoring a wear state of a carbon brush or an associated rotating component of an electrical machine. The brush holder assembly may include a carbon brush, a spring for providing a force to engage the carbon brush with a rotating component of an electrical machine and a wear state sensor. The wear state sensor may include a bend sensor, a comparator, an indicator and a communication circuit. The comparator may compare a signal received from the bend sensor to a predetermined threshold value to determine a wear state of at least one of the carbon brushes and the rotating component of the electrical machine. The indicator may provide an indication of the wear state of at least one of the carbon brushes and the rotating component of the electrical machine to a user. The communication circuit may communicate information about the wear state of at least one of the carbon brushes and the rotating component of the electrical machine to a site monitor proximal to the electrical machine.

The above summary of some example embodiments is not intended to describe each disclosed embodiment or every implementation of the aspects of the disclosure.

BRIEF DESCRIPTION OF THE DRAWINGS

The aspects of the disclosure may be more completely understood in consideration of the following detailed description of various embodiments in connection with the accompanying drawings, in which:

FIG. 1 shows an illustrative view of an exemplary brush monitoring system;

FIGS. 2A and 2B are perspective views of the illustrative wear state sensor of FIG. 1.

FIG. 3 shows a side view of the brush holder assembly including the illustrative wear state sensor of FIGS. 1 and 2.

FIG. 4 is a block diagram representation of the illustrative wear state sensor of FIGS. 1-3.

FIGS. 5A and 5B are perspective views of an illustrative flexible sensor.

FIGS. 6A and 6B show side views of an illustrative brush holder assembly having a particular wear state of a carbon brush.

FIG. 7 is a block diagram representation having an illustrative site monitor.

FIG. 8 illustrates an exemplary bus of mounting blocks and brush holder assemblies of an electrical machine utilizing a unique identification system to reference a position of a brush holder and associated brush on the electrical machine.

FIG. 9 shows a graph of an illustrative voltage associated with the variable resistance of the flexible sensor associated with the wear state of a carbon brush.

FIG. 10 shows a graph of an example of a transient voltage signal illustrative of a condition of a rotating component of an electrical machine.

FIG. 11 shows an illustrative method for monitoring a wear state of one or more components of an electrical device.

While the aspects of the disclosure are amenable to various modifications and alternative forms, specifics thereof have been shown by way of example in the drawings and will be described in detail. It should be understood, however, that the intention is not to limit aspects of the disclosure to the particular embodiments described. On the

contrary, the intention is to cover all modifications, equivalents, and alternatives falling within the spirit and scope of the disclosure.

DETAILED DESCRIPTION

For the following defined terms, these definitions shall be applied, unless a different definition is given in the claims or elsewhere in this specification.

All numeric values are herein assumed to be modified by the term “about”, whether or not explicitly indicated. The term “about” generally refers to a range of numbers that one of skill in the art would consider equivalent to the recited value (i.e., having the same function or result). In many instances, the term “about” may be indicative as including numbers that are rounded to the nearest significant figure.

The recitation of numerical ranges by endpoints includes all numbers within that range (e.g., 1 to 5 includes 1, 1.5, 2, 2.75, 3, 3.80, 4, and 5).

Although some suitable dimensions, ranges and/or values pertaining to various components, features and/or specifications are disclosed, one of skill in the art, incited by the present disclosure, would understand desired dimensions, ranges and/or values may deviate from those expressly disclosed.

As used in this specification and the appended claims, the singular forms “a”, “an”, and “the” include plural referents unless the content clearly dictates otherwise. As used in this specification and the appended claims, the term “or” is generally employed in its sense including “and/or” unless the content clearly dictates otherwise.

The following detailed description should be read with reference to the drawings in which similar elements in different drawings are numbered the same. The detailed description and the drawings, which are not necessarily to scale, depict illustrative embodiments and are not intended to limit the scope of the disclosure. The illustrative embodiments depicted are intended only as exemplary. Selected features of any illustrative embodiment may be incorporated into an additional embodiment unless clearly stated to the contrary.

FIG. 1 shows an illustrative view of an exemplary brush monitoring system **100** that may include a brush holder assembly **110**, a site monitor **120** and/or a remote monitoring site **140** including a remote monitoring device **150**, **160**. In some cases, the brush holder assembly **110** may substantially resemble a brush holder assembly as described in U.S. Pat. No. 7,034,430, entitled “BRUSH HOLDER APPARATUS, BRUSH ASSEMBLY, AND METHOD”, which is herein incorporated by reference in its entirety. However, the illustrative brush monitoring system **100** may be amenable to any of various brush holder assembly configurations. Thus, the intention is that the illustrative brush monitoring system **100** may be used in conjunction with any desired brush holder assembly configurations of an electrical device, such as an industrial electrical generator. For example, the illustrative brush monitoring system **100** may be used with brush holder assemblies, brush holders and/or brushes disclosed in U.S. Pat. Nos. 6,731,042; 5,753,992; 5,621,262; 5,463,264; 5,397,952; and 5,256,925; each of which is incorporated herein by reference.

The brush holder assembly **110**, for example as shown in FIG. 1, may include a brush holder **22**, such as a brush box, surrounding a brush **24** on several sides and including a plurality of guiding surfaces for guiding linear or longitudinal movement of the brush **24**. In some embodiments, the brush holder **22** may not take on the form of a box, but may

5

include one or a plurality of guiding surfaces, such as channels, posts or columns, abutting and/or encompassing one or more sides of the brush 24 and/or extending into or through the brush 24, or a portion thereof, for guiding linear or longitudinal movement of the brush 24.

The brush holder 22 may be secured to a mounting beam 26 configured and adapted to be mounted to another structure, such as a mounting block 70. The brush holder assembly 110 may be configured to place the brush 24 in contact with a conductive surface 12, such as a surface of a rotating component 15 of an electrical machine, such as a collector ring, a slip ring, or a commutator, and conduct current therefrom. The brush 24 may extend from the lower edge of the brush holder 22 such that a wear surface of the brush 24 engages the conductive surface 12. The mounting beam 26 may include an over-center engagement mechanism, a slotted or channeled engagement mechanism for sliding engagement, or other mechanism for easily engaging and disengaging the brush 24 from a conductive surface 12. In other embodiments, the brush holder assembly may include a brush holder rigidly mounted to another structure holding the brush holder stationary, or mounted to another structure in any desired arrangement. For example, in some embodiments the brush holder may be bolted or welded to a stationary structure. Some such brush holders are disclosed in U.S. Pat. Nos. 6,731,042; 5,753,992; 5,621,262; 5,463,264; 5,397,952; and 5,256,925; which are incorporated herein by reference.

As shown in FIG. 1, the mounting beam 26 may include an upper beam member 27 and a lower beam member 28 hingedly or pivotally coupled to one another. When the upper beam member 27 and the lower beam member 28 are aligned with one another (e.g., the longitudinal axis of the upper beam member 27 is parallel with the longitudinal axis of the lower beam member 28), the brush holder 22 may be considered to be in an engaged, or locked, position such that the brush 24 may be contiguous with or in contact with the conductive surface 12. When the upper beam member 27 is tilted from the lower beam member 28 (e.g., the longitudinal axis of the upper beam member 27 is oblique to the longitudinal axis of the lower beam member 28), the brush holder 22 may be considered to be in a disengaged, or unlocked, position such that the brush 24 may be non-contiguous with, spaced from, or otherwise not in direct electrical contact with the conductive surface 12. The mounting beam 26 may be removably coupled to the mounting block 70 during operation. In some embodiments, the mounting beam 26 may slidably engage with, interlock with, or otherwise be removably coupled to the mounting block 70. The mounting block 70 may be coupled to, secured to, or otherwise extend from another structure which maintains the mounting block 70 stationary with respect to the conductive surface 12, for example.

In some embodiments, a handle 21 may be attached to the brush holder 22 to facilitate engagement and disengagement of the brush 24 from the conductive surface 12. For example, the handle 21 may be attached to the upper beam member 27 such that movement of the handle 21 actuates (e.g., pivots, slides, releases) the upper beam member 27 relative to the lower beam member 28. The handle 21 may be a removable handle or the handle 21 may be permanently attached to the upper beam member 27 or another portion of the brush holder 22.

Also illustrated in FIG. 1 is a spring 29, such as a constant force spring, which provides tension to the brush 24 to bias the brush 24 toward and in contact with the conductive surface 12. The spring 29 may be attached to a portion of the

6

brush holder 22 or the mounting beam 26 of the brush holder assembly 110, for example. In some embodiments, the spring 29 may extend along one side surface of the brush 24 between the brush 24 and the mounting beam 26 of the brush holder assembly 110.

The brush holder assembly 110 may further include a wear state monitor 50 and a flexible sensor 60, wherein the wear state monitor 50 may be communicatively coupled to the flexible sensor 60. For example, the wear state monitor 50 may receive a signal representative of the position and/or movement of the brush 24. In some cases, the wear state monitor 50 may be positioned adjacent to the spring 29. For example, the wear state monitor 50 may be mounted adjacent a surface of the spring 29 or otherwise with the spring 29, such as within a coil formed by the spring 29, as shown in FIG. 3. The wear state monitor 50 may include one or more indicators 55 to communicate the physical status of the brush 24, the conductive surface 12, or both. In some cases, the indicators 55 may include one or more light emitting diodes (LEDs), a speaker, or a combination of LEDs and/or speakers for communicating wear state information to a user. In some cases, the wear state monitor 50 may be positioned adjacent to a surface of a component of the brush holder assembly 110, different than the spring 29. For example, the wear state monitor 50 may be positioned on or adjacent to the brush holder 22, the lower beam member 28, the upper beam member 27, on or adjacent to one or more shunts of the brush holder assembly 110, and/or on or adjacent to the handle 21 of the brush holder assembly 110. In some cases, the wear state monitor 50 may be permanently and/or removably incorporated into a portion of the handle 21 or other component of the brush holder assembly 110.

The flexible sensor 60 may also be positioned adjacent to the spring 29, such that a movement of the brush 24 may cause the flexible sensor 60 to flex or otherwise change shape. For example, a proximal end of the flexible sensor 60 may be attached to a portion of the brush holder 22 or the mounting beam 26 of the brush holder assembly 110 and a distal end may be attached to and/or communicatively coupled to the wear state monitor 50. In some cases, the flexible sensor 60 may be attached to, embedded in, in contact with the spring 29 and track or follow the movement of the brush 24. For example, the flexible sensor 60 may be affixed to a surface (e.g., an inner surface, an outer surface, etc.) of the spring 29. In another example, the flexible sensor 60 may be positioned adjacent to the spring 29. As such, any movement of the flexible sensor 60 may directly correspond to movement of the brush 24.

For example, a signal corresponding to the resistance value of the flexible sensor 60 may be equivalent, proportional, or otherwise representative of the linear or longitudinal movement, vibration and/or diminution of the brush 24. In some cases, the wear state monitor 50 may associate a steady-state resistance value of the flexible sensor 60 with a wear state of the brush 24 and/or a transient resistance value with a wear state of the conductive surface 12 and/or the rotating component 15. The steady state resistance value of the flexible sensor 60 may correspond to a value obtained over one or more revolutions of the rotating component 15 and may correspond to the position of the upper surface of the brush 24 relative to the conductive surface 12 of the rotating component 15. In some cases, the transient resistance value of the flexible sensor 60 may correspond to a value obtained over at least a portion of a revolution of the rotating component 15, such as a resistance value caused by a vibration of the brush 24 caused by variances in the

conductive surface **12** of the rotating component **15**. The steady-state electrical value (e.g., a voltage level) may be compared to one or more predetermined threshold values to determine a wear state of the brush **24**. Similarly, the transient electrical value may be associated with a vibration of the brush **24** and may be monitored and/or compared to one or more predetermined thresholds to determine a wear state of the conductive surface **12** of the slip ring or other rotating component of the electrical machine.

The flexible sensor **60** may have an electrical resistance that varies based on a radius of curvature of the flexible sensor **60** and may produce a signal (e.g., a voltage based signal, a current based signal, etc.) corresponding to the electrical resistance of the flexible sensor **60**. In some cases, the radius of curvature of the flexible sensor **60** may be associated with a deflection of the spring **29** providing a force to engage the carbon brush with a rotating component of the electrical machine. The electrical resistance of the flexible sensor **60** may be used with other electrical components to provide a signal representative of the electrical resistance of the flexible sensor **60**. For example, the resistance of the flexible sensor **60** may be used as a component in a voltage divider circuit that is configured to provide a voltage signal that corresponds to the variable resistance of the flexible sensor **60**. In other cases, an electrical circuit associated with the flexible sensor **60** may be configured to provide a current signal representative of the variable electrical resistance of the flexible sensor **60**.

In some cases, the brush monitoring system **100** may include a site monitor **120** that may be positioned near the electrical machine to monitor the wear state of one or more brush holder assemblies **110** and/or the wear state of the slip ring or other rotating component of the electrical machine. The site monitor **120** may be capable of monitoring the wear states of the brush **24** of the brush holder assembly **110**. In some cases, the site monitor **120** may be capable of monitoring the movement of the brushes **24** of two or more brush assemblies **110** associated with one or more electrical machines. For example, the site monitor **120** may be communicatively coupled to one or more wear state monitors **50** associated with a particular electrical machine, such as the wear state monitor **50** of the brush holder assembly **110** via a communication link **115** (e.g., a wireless link). The site monitor **120** may be configured to receive processed data and/or raw data providing information about the wear state of the brush **24** and/or the rotating component **15**. For example, the site monitor **120** may receive information about a comparison between a value received from the flexible sensor **60** and one or more predetermined thresholds, the value received from the flexible sensor **60**, or both. In some cases, the communication link **115** may include a radio frequency (RF) communication link, an audio-based communication link (e.g., an ultrasonic communication link), and/or an optical communication link (e.g., an infrared (IR) communication link, a visible light communication link, etc.). In some cases, the site monitor **120** may be configured to predict or determine an estimated projection of a condition of the brush **24** into the future.

In some cases, the wear state monitor **50** may be configured to communicate the wear state information about the brush **24** and/or the rotating component **15** of the electrical machine to the site monitor **120** using a predetermined schedule (e.g., once per hour, once per day, twice per week, etc.). In some cases, the wear state monitor **50** may provide the wear state information about the brush **24** and/or the rotating component **15** of the electrical machine to the site

monitor **120** in response to a command received from the site monitor **120** and/or the remote monitoring device **150**, **160**.

The site monitor **120** may output an indication of the condition and/or projected condition of the brush **24**. In some cases, the indication may be configured to alert an operator, technician and/or other personnel that the brush **24** and/or the rotating component **15** are sufficiently worn and/or needs to be replaced, the brush **24** and/or the rotating component **15** are damaged, failure has occurred or is imminent, or other maintenance or inspection may need to be performed. In some embodiments, the indication may be used for scheduling maintenance or inspection, sending personnel to perform maintenance or inspection, ordering and/or scheduling distribution/delivery of a replacement brush or other part, routing maintenance personnel and/or product delivery to a specified location, or arranging for other notification and/or scheduling tasks be performed.

The brush monitoring system **100** may also be used to identify and/or notify other key maintenance, failure of the brush holder assembly **110** and/or other anomalous conditions. For example, incidents of excess heating, arcing or excess vibration, which may indicate a need to perform maintenance and/or disrupt operation of the electrical equipment, may be identified and/or assessed by one or more components of the brush monitoring system **100**. The wear state monitor **50**, the site monitor **120** and or the remote monitoring device **150**, **160** may carry out an appropriate response to respond to an identified anomalous condition in an attempt to rectify the anomalous condition. In some cases, an operator may carry out an appropriate response to respond to an anomalous condition identified with the brush monitoring system **100** in an attempt to rectify the anomalous condition.

In some cases, the site monitor **120** may be communicatively coupled by a wireless link **125** and/or wired link **127** to a network **130**. The site monitor **120** may be capable of communicating information about the wear state of one or more brushes to a remote monitoring device **150**, **160** at a remote monitoring site **140** via the network **130** and one or more wired **137** and/or wireless **135** communication links. The wired link **127**, **137** and/or wireless link **125**, **135** communication links may be configured to operate using one or more standardized communication protocols (e.g., Ethernet, Ethernet/IP, BACnet, Modbus, LonWorks, etc.), or proprietary communication protocols. Examples of a remote monitoring system are described in U.S. Pat. No. 7,705,744, entitled "MONITORING SYSTEMS AND METHODS FOR MONITORING THE CONDITION OF ONE OR MORE COMPONENTS OF AN ELECTRICAL DEVICE", and U.S. patent application Ser. No. 11/752,965 entitled "BRUSH HOLDER ASSEMBLY MONITORING APPARATUS, ASSEMBLY, SYSTEM AND METHOD" and has the U.S. Patent Publication No. 2008/0291273 which are herein incorporated by reference in their entirety. The remote monitoring site **140** may include one or more remote monitors, such as a personal computer **160**, a workstation, a laptop, a tablet **150**, a smart phone or the like, for collecting data and/or analyzing data received from one or more user sites.

The remote monitoring devices and/or site monitor **120** may be integrated into a maintenance program for a brush holder assembly **110**, such that the site monitor **120** may be configured to monitor at least a condition of one or more components of the brush holder assembly **110**. To do so, the remote monitors and/or the site monitor **120** may be configured to identify each brush holder assembly **110** on a

particular machine or at a particular site and/or store an installation date and any servicing dates for each brush holder assembly **110**. In some cases, one or more parameters received from the wear state monitor **50** associated with a brush holder assembly **110** may be monitored over time to determine trending information about a brush **24** and/or a rotating component **15** of the electrical machine. For example, the site monitor **120** and/or the remote monitors may determine trend information, that may include an average lifetime for a brush **24** installed in a particular brush holder assembly **110** and/or for a particular installation position on an electrical machine. The site monitor **120** and/or the remote monitors may be configured to store information about the position of a brush (e.g., a resistance value of the flexible sensor **60**), when the brush holder assembly **110** is first installed on an electrical machine. By monitoring the initial position each time a brush **24** is replaced in the brush holder assembly **110**, information may be gathered about a wear state of the rotating component **15**. For example, a slip ring, or other rotating component of the electrical machine, may have an initial outer diameter measurement. Over time, with wear including normal wear and/or due to environmental conditions (e.g., humidity, temperature, contaminants including abrasives, etc.) a wear state associated with the thickness and/or outer diameter of the rotating component **15** may be measured and/or predicted. In some cases, preventative measures to improve the lifetime of the brush **24** and/or the rotating component **15** may be obtained by analysis of the information received from the one or more wear state monitors **50**. For example, a user may be advised to adjust one or more environmental conditions for a space near the electrical machine, such as a temperature, a humidity level and/or a contaminant level.

FIGS. **2A** and **2B** are perspective views **200**, **250** of the illustrative wear state monitor **50** of FIG. **1**. The wear state monitor **50** may include a body **210**, one or more ribs **220**, an opening **225** to facilitate an electrical connection to the flexible sensor **60**, one or more communication interfaces **230**, and one or more indicators **240**. In some cases, the wear state monitor may include a user interface **260**. The body **210** may be generally cylindrical, or other such shape designed to facilitate integration into a brush holder assembly **110** or other mounting location within the brush holder assembly **110**. For example, the wear state monitor **50** may be configured to be associated with the spring **29** of the brush holder assembly **110**, as shown in FIG. **3**. The body **210** of the wear state monitor **50** may be designed to be captured within a coiled portion of the spring **29**. The ribs **220**, or other similar structure, may be used to ensure the wear state monitor **50** remains mounted within the coil. The ribs **220** may be removable, or otherwise configurable, to allow the wear state monitor **50** to be mounted within a coil of two or more different sized springs. For example, the removable and/or configurable ribs, such as the ribs **220**, may allow the wear state monitor **50** to be mounted within a spring having a first width and a first coil diameter and/or a spring having a second width and/or a second diameter.

The opening **225** of the wear state monitor **50** may be used to facilitate a connection with the flexible sensor **60**. For example, the opening **225** may allow access to an electrical connection, such as a screw terminal. The opening **225** may have a shape corresponding to a cross-sectional shape of the flexible sensor (e.g., a slot), or may be another shape (e.g., a circular opening, a rectangular opening, etc.) designed to accommodate an electrical connection to the flexible sensor **60**.

As discussed above, the wear state monitor **50** may be configured to determine one or more wear states of the brush **24** and/or the rotating component **15** of the electrical machine using information obtained using the flexible sensor **60** (e.g., a variable resistance, a voltage signal, a current signal, etc.). In some cases, the wear state monitor **50** may include one or more electrical connections for providing an electrical connection to the flexible sensor **60**. The electrical connections may be located within an interior space of the wear state monitor **50**, such that the flexible sensor **60** may be integrated with the wear state monitor **50** and may extend through the opening **225** to provide a direct electrical connection between the wear state monitor **50** and a portion of the flexible sensor **60**. In some cases, one or more wires (e.g., individual wires, a shielded twisted-pair cable, a ribbon cable, etc.) may extend through the opening **225** to facilitate an electrical connection to the flexible sensor **60**. The electrical connections may be formed as a permanent and/or semi-permanent electrical connection, using solder, a conductive epoxy, screw terminals, spring terminals, a compression fitting, a snap fitting, a crimp fitting, or the like. The electrical connections may be accessible to a user with or without disassembly of at least a portion (e.g., a cover) of the wear state monitor **50**. For example, a user may be capable of accessing a terminal via the opening **225** and/or by removing a removable cover that may comprise an end **201**, **203** of the wear state monitor **50**. The cover may be secured by a threaded connection, a snap-fit connection and/or one or more connectors (e.g., screws). In some cases, the exterior housing of the wear state monitor **50** may be configured in two or more sections that may be hingedly connected (e.g., a "clam shell" configuration), or otherwise movable relative to one another. In such cases, when the wear state monitor **50** is located within the coiled portion of the spring **29** (e.g., a helical spring), the force provided by the spring **29** may facilitate a compression connection or snap fit connection for the hingedly connected sections of the housing of the wear state monitor **50**. Also, the force provided by the spring **29** may also facilitate a compression connection or other pressure based electrical connection between the wear state monitor **50** and the flexible sensor **60**. In some cases, the flexible sensor **60** may be electrically connected to the wear state monitor using an interface (e.g., one or more terminals, one or more bonding pads, etc.) located at an end **201**, **203** and/or on the body **210** of the wear state monitor **50**. In some cases, an externally accessible electrical connection interface for the flexible sensor **60** may extend above the surface of the wear state monitor **50**, or may be recessed in a cavity formed into the exterior surface of one or more of the ends **201**, **203** or the body **210**.

The wear state monitor **50** may be capable of communicating information about the wear state of the brush **24** and/or the rotating component **15** to a user via the communication interface **230** and/or the indicators **240**. The communication interface **230** and/or the indicators **240** may be located at the same or different surface of the wear state monitor **50**. For example, the communication interface **230** may be located at a first end **201** of the wear sensor and the indicators **240** may be located at a second end **203** of the wear state monitor, but this is not required. The communication interface **230** may be capable of transmitting information via one or more communication protocols using audio energy (e.g. an ultrasonic signal), radio frequency (RF) energy (e.g., an RF signal), and/or light energy (e.g., an optical signal, an infrared (IR) signal, etc.), or the like.

In some cases, the wear state monitor **50** may be capable of receiving messages from an external device, such as the

11

site monitor 120 and/or a programming device located at the same site or at a remote location (e.g., a computer 150, a tablet 160, a smart phone, etc.). The messages may include commands, such as commands to send wear state information about the brush 24 and/or the rotating component 15, or commands for modifying information used by the wear state monitor 50. For example, a user may desire to modify one or more thresholds used to determine the wear state information of the brush 24 and/or the rotating component 15, and/or to reprogram the wear state monitor 50 by downloading instructions, tables and/or the like (e.g., compiled code). In some cases, the wear state monitor 50 may include one or more user interfaces 260 that may be used for programming or otherwise providing information about the location and/or function of the wear state monitor 50. For example, a user may use the user interface 260 as a programming interface to modify one or more thresholds and/or to reprogram the wear state monitor 50 rather than using the communication interface 230. For example, a user may connect a programming device via a cable or use one or more memory devices (e.g., a flash card, a universal serial bus (USB) drive, etc.) to download and/or upload information from the wear state monitor 50. In some cases, the user interface 260 may include one or more switches (e.g. a dual inline package (DIP) switch, a rotary position switch, etc.) to associate the wear state monitor 50 with a particular brush assembly 110 and/or a particular installed position at the electrical machine and/or at the customer site.

The indicators 240 may include one or more optical indicators (e.g. LEDs) and/or one or more audio indicators (e.g., a speaker) for providing an optical and/or audible indication of the wear state of the brush 24 and/or the wear state of the rotating component 15. For example, indicators 240 of the wear state monitor 50 may include one or more LEDs, wherein the one or more light emitting diodes (LED) may be configured to emit light of a first color when the wear state monitor 50 determines a first wear state of the brush 24 and to emit light of a second color when the wear state monitor 50 determines a second wear state of the brush 24. In some cases, additional colors may be used to indicate additional wear states of the brush 24. The indicators may use the same and/or different ones of the one or more LEDs to indicate the wear state information of the rotating component 15. For example, the one or more LEDs may be configured to emit light of a third color when the wear state monitor 50 determines a first wear state of the rotating component 15 and to emit light of a fourth color when the wear state monitor 50 determines a second wear state of the rotating component 15. In some cases, additional colors may be used to indicate additional wear states of the rotating component 15. In some cases, a first set of LEDs may be configured to provide wear state information about the brush 24 and a second set of LEDs for indicating wear state information about the rotating component 15.

For example, the wear state monitor 50 may include one or more LEDs configured to emit light of a first color (e.g., green) when the wear state monitor 50 determines that the brush 24 has an operational wear state, to emit light of a second color (e.g., yellow) when the wear state monitor 50 determines that the brush 24 is approaching the replacement wear state, and to emit light of a third color (e.g., red) when the wear state monitor 50 determines that the brush 24 has reached the replacement wear state. In some cases, the wear state monitor 50 may be configured to illuminate a different number of LEDs and/or a pattern of LEDs, of the same or different colors, to indicate one or more particular wear state conditions of the brush 24 and/or the rotating component 15.

12

In another example, the wear state monitor 50 may be configured to provide a first audible indication of the wear state of the brush 24 (e.g., an intermittent tone) when the wear state monitor 50 determines that the brush 24 is approaching the replacement wear state, and to provide a second audible indication of the wear state of the brush 24 (e.g., a different intermittent tone, a tone at a different frequency, a steady tone, etc.) when the wear state monitor 50 determines that the brush 24 has reached the replacement wear state.

FIG. 3 shows an exploded perspective view of the brush holder assembly 110 in an engaged position and including the illustrative wear state monitor 50 of FIGS. 1 and 2. In some cases, the brush holder assembly 110 may include an integral flexible sensor 60 that may be used for monitoring a wear state of the brush 24 and/or an associated rotating component 15 of an electrical machine. The brush holder assembly 110 may include the brush 24 (e.g. a carbon brush) and a spring 29 associated with the brush 24. The spring 29 may provide a force to engage the brush 24 with a rotating component of an electrical machine, such as a slip ring, a commutator, and the like. For example, the spring 29 may include a coil portion 310 that may be used to apply the force to the brush 24. The wear state monitor 50 may be positioned adjacent to the spring 29. In some cases, the wear state monitor 50 may be positioned substantially within the coil 310.

In some cases, the flexible sensor 60 may be positioned adjacent to the spring 29 such that the changing bend radius of the spring 29 associated with the movement and/or wear of the brush 24 causes a corresponding bend radius on the flexible sensor 60. For example, the flexible sensor 60 may be affixed or otherwise positioned adjacent to a surface of the spring 29. In another example, the flexible sensor 60 may be positioned adjacent to an edge of the spring 29.

Other configurations for positioning the flexible sensor 60 in relation to the spring 29 and/or brush 25 may be contemplated. For example, a portion of the flexible sensor 60 may be affixed to one or more other components of the brush holder assembly 110 (e.g., the brush holder 22, the handle 21, the upper beam member 27, the lower beam member 28, and the like). In such cases, a different portion of the flexible sensor 60 may be communicatively coupled to the wear state monitor 50 located in the coil portion 310 of the spring 29 or other location of the brush holder assembly 110. In some cases, the flexible sensor 60 may have a first bend radius upon initial installation of the brush 24 that is less than the bend radius after the brush 24 is worn. In other cases, the flexible sensor 60 may have a first bend radius upon initial installation that is greater than the bend radius after the brush 24 is worn. In some instances, the flexible sensor 60 may have a configuration such that the bend sensor 60 does not have a bend radius, such as when the bend sensor 60 is substantially aligned along a plane. For example, the bend radius of the flexible sensor 60 may have a positive bend radius upon installation and a negative bend radius after the brush is worn, or a negative bend radius upon installation and a positive bend radius after the brush is worn, or the bend sensor may be substantially aligned along a plane at initial installation or after a particular amount of wear to the brush 24. In some cases, two or more flexible sensors 60 may be used for monitoring the wear states of the brush 24 and/or the rotating component 15. The two or more flexible sensors 60 may be positioned adjacent to different portions of the spring, such that a first flexible sensor 60 may be used to monitor the wear state of the brush 24 and/or the rotating component 15 over a first duration of time and a second

flexible sensor **60** may be used to monitor the wear state of the brush **24** and/or the rotating component **15** over a second duration of time. The first and second durations of time may overlap in some instances. In an illustrative example, the first flexible sensor **60** may be at least partially bent (e.g., positioned near the coil of the spring **29**) and the second flexible sensor **60** may be significantly straight (e.g., positioned near the lower beam member **28**), such that the wear state monitor **50** may be configured to primarily or solely use information from the first flexible sensor **60** during a duration of time after installation of the brush assembly **110** on the machine, a combination of information received from both the first and second flexible sensors during a second duration of time during normal operation, and information received primarily or solely from the second flexible sensor at a third duration of time, such as a duration of time when the brush **24** is approaching a replacement wear state or is otherwise near a replacement wear state. In some cases, a sensor other than a flexible sensor having a variable resistance may be contemplated to obtain information about an amount of wear to the brush **24** and/or an amount of wear to the rotating component **15** in relation to a movement of the spring **29**. Obtaining information about an amount of wear to the rotating component **15** includes obtaining information about an amount of wear to the surface **12** of the rotating component **15**. In some cases, one or more wires may be positioned adjacent to the spring **24**. For example, a portion of one or more wires may be affixed to the spring **24**. In some cases, an opening in a portion of an insulating layer around the one or more wires may be present to expose a portion of the wire. In such cases, the exposed and/or un-insulated portion of the wire may contact another surface (e.g., a surface of the spring **29**, a surface of the brush **24**, or another surface associated with the brush assembly **110**), which may cause the wire to conduct electricity and/or stop conducting electricity. In some cases a first wire may be positioned to indicate a known wear state of the brush **24**, such as an initial wear state condition, a wear state approaching a replacement wear state condition of the brush **24**, and/or a replacement wear state condition of the brush **24**. In some cases, a second or additional wire may be positioned to indicate another wear state of the brush **24** different from the first wear state. For example, a first wire may be used to indicate a wear state approaching a replacement wear state, and a second wire may be used to indicate a replacement wear state of the brush **24**. In some cases, the wire may be associated with one or more resistors, and/or other electrical components. In such cases, as the wear state of the brush **24** changes, different ones of the one or more electrical components (e.g., transistors, LEDs, resistors, etc.) may be included in an electrical circuit. For example, a first resistance value may be associated with a first particular wear state and a second resistance value may be associated with a second particular wear state. In some cases, the wear state monitor **50** may include a sensor or other device to at least partially identify a vibration or other movement corresponding to a wear state of the rotating component **15**. For example, an acceleration and/or a pressure sensor may be associated with the wear state monitor **50** and information received from the acceleration and/or the pressure sensor may be used to identify a characteristic (e.g., a magnitude, a frequency, etc.) of a vibration of the brush **24**. The wear state monitor **50** may use this information in addition to or in place of information received from the flexible sensor **60**, such as a bend sensor, or other sensor (e.g., a temperature sensor, a humidity sensor, etc.) to determine whether the wear state of the

rotating component **15** is approaching a maintenance wear state or has reached a required maintenance wear state.

The wear state monitor **50** may be communicatively coupled to the flexible sensor **60** to receive a signal corresponding to the wear state of at least one of the brush **24** and the rotating component **15**. The wear state monitor **50** may be configured to determine the wear state of the brush **24** and/or the rotating component **15** using a comparator by comparing the signal received from the flexible sensor **60** to at least one predetermined threshold. The wear state monitor **50** may provide the determined wear state information about the brush **24** and/or the rotating component **15** to a user via an indicator provided on the wear state monitor **50** and/or a communication circuit capable of communicating to an external device, such as the site monitor **120**, via a communication link.

FIG. **4** is a block diagram representation of the illustrative wear state monitor **50** of FIGS. **1-3**. In an example, the illustrative wear state monitor **50** may be communicatively coupled to a sensor, such as the flexible sensor **60** to obtain information about the wear state of the brush **24** and/or the rotating component of the electrical machine. In this illustrative embodiment, the wear state monitor **50** may include one or more of an input/output block (I/O block) **410**, a signal conditioning circuit **420**, a comparison circuit **430** (e.g., a comparator), a processor **440** (e.g. a microprocessor, a microcontroller, etc.), a user interface **450**, a communication circuit **470**, a memory **480** and/or a data port **490**. In some cases, the wear state monitor **50** may include a power source **460**, such as a battery, a capacitor, or both. In some cases, the battery may be rechargeable and/or replaceable. In some cases, the wear state monitor **50** may include energy harvesting capability, such that the power source **460** may receive energy and/or may be recharged by one or more energy harvesting technologies. For example, illustrative energy harvesting technologies may include a kinetic (e.g., vibrational) energy harvester (e.g., a piezoelectric vibration energy harvester, a magneto-inductive vibration energy harvester, etc.), a photovoltaic energy harvester capable of harvesting energy indoors and/or outdoors, a piezoelectric energy harvester, a thermal energy harvester, a wind energy (e.g., microturbine) harvester, and/or an ambient radiation (e.g. radio frequency) energy harvester.

In some cases, in addition to or instead of the power source **460**, the wear state monitor **50** may include one or more connectors and/or terminals capable of receiving power from a source separate from the wear state monitor **50**. In such cases, the wear state monitor **50** may be configured to receive power from an external power source when the brush holder assembly **110** is installed on the electrical machine. For example, an electrical circuit to the wear state monitor **50** may be completed when the brush holder assembly **110** is coupled to the mounting block **70** such that electrical power may pass from a power source through the mounting block **70** to the wear state monitor **50**. In such a configuration, electrical power may be automatically provided to the wear state monitor **50** when the brush holder assembly **110** is mounted onto the mounting block **70** of the electrical machine, and electrical power to the wear state monitor **50** may be discontinued when the brush holder assembly **110** is removed from the mounting block **70**. In some cases, the I/O block **410** may include one or more connectors **415** (e.g., screw terminals, spring terminals, etc.) for connecting the flexible sensor **60** to the wear state monitor **50**. In some cases, the I/O block **410** may be located within the wear state monitor **50** or may be positioned on or near an external surface of the wear state monitor **50**. For

example, the I/O block **410** may be positioned within a cavity within the wear state monitor **50** and accessible via an opening and/or a removable cover. A signal received from the flexible sensor **60** may be conditioned by the signal conditioning circuit **420**.

The signal conditioning circuit **420** may be configured to perform filtering, amplification, buffering, and/or other adjustments to the amplified pressure indicating signal. In some cases, the signal conditioning circuit **420** may include one or more discrete components (e.g., resistors, transistors, capacitors, inductors, diodes, etc.) and/or integrated circuits (e.g., operational amplifiers, buffers, ASICs, etc.). In some cases, the signal conditioning circuit **420** may include one or more filters **422**. The filters **422** may be implemented as a combination of integrated or discrete elements, such as a resistor and a capacitor configured as a series RC network (e.g., a low-pass filter). Although a first order low-pass filter may be used, it is contemplated that any combination of analog or digital filters can be used, including one or more high pass filters, low pass filters, band pass filters, notch filters, passive filters (e.g., having “T” sections, “π” sections, etc.), active filters (e.g., Chebyshev filter, Butterworth filter, etc.), IIR filters, FIR filters, and/or any other suitable filter or filter combination.

The signal received from the flexible sensor **60** may then be compared to one or more predetermined thresholds using the comparison circuit **430**. In some cases, the threshold for the one or more thresholds may be set using one or more discrete electrical components, such as one or more resistors, capacitors, inductors, diodes, transistors, and/or integrated circuits, such as a comparator and/or a processor. In some cases, the processor **440** may read the threshold from a memory **480** and/or compute the threshold using one or more instructions stored in the memory **480**. In some cases, the specified threshold may be fixed at a pre-determined level. In other cases, the specified threshold may be configurable and/or adaptable, as desired. For example, the one or more thresholds may be configurable by a user during a calibration procedure before and/or after the wear state monitor **50** is installed in a brush holder assembly **110**. During an illustrative calibration procedure, the user may obtain one or more steady-state values from the flexible sensor **60** after the flexible sensor **60** is installed in the brush holder assembly **110**. For example, the obtained values may correspond to a first position of the brush **24**, such as an engaged position when the brush **24** has approximately no wear and a second position corresponding to a brush position approximating a position when the brush **24** has a predetermined amount of wear (e.g., approaching the replacement threshold, maximum allowable wear, etc.). Calibration may be important due to one or more mechanical and/or electrical differences between particular brush assemblies. In some cases, a user may communicate a threshold value via a communication interface, such as the communication circuit **470**, the user interface **450** (e.g., using one or more switches **454** and/or potentiometers **458**), and/or the data port **490**, such as from an external memory device (e.g., a flash memory device, etc.).

The processor **440** may operate using an algorithm for determining a wear state indication of at least one of the brush **24** and the rotating component **15** and/or communicates one or more indication of the wear state of the brush **24** and/or rotating component **15** to a user. The processor **440** may, for example, operate using an algorithm that causes the wear state monitor **50** to obtain information corresponding to a bend radius of the flexible sensor **60** continuously or at predetermined intervals. In some cases,

wear state monitor **50** may include a timer **445** and/or an analog to digital converter (ADC) **447**. The timer **445** and/or the ADC **447** may be integral to the processor **440** or may be provided as a separate component. In some cases, one or more components and/or functionality of the signal conditioning circuit **420** and/or the comparison circuit **430** may be incorporated into the instructions processed by the processor **440**.

The memory **480** of the illustrative wear state monitor **50** may be in communication with the processor **440**. The memory **480** may be used to store any desired information, such as the aforementioned control algorithm, threshold values, schedule times, sampling times, trending information, and the like. The memory **480** may be any suitable type of storage device including, but not limited to, RAM, ROM, EPROM, flash memory, a hard drive, and/or the like. In some cases, the processor **440** may store information within the memory **480**, and may subsequently retrieve the stored information.

In the illustrative embodiment of FIG. **4**, the user interface **450** may be any suitable user interface that permits the wear state monitor **50** to display and/or solicit information. In some cases, the user interface **450** may accept one or more user interactions with the wear state monitor **50** and/or may permit the wear state monitor **50** to display, or otherwise convey, information about the wear state of the brush **24** and/or the rotating component **15**. For example, the user interface **450** may include one or more indicators, such as LEDs **452** or speakers **456**, capable of providing the indication of the determined wear states to the user. The LEDs **452** may include one or more LEDs **452** capable of emitting one or more colors, the colors and/or the lack of colors being representative of a corresponding wear state. For example, an unlit LED and/or an LED emitting a green light (optional) may indicate an operational or “good” wear state, an LED emitting a yellow light may indicate a wear state where the associated component may be approaching a replacement wear state, and an LED emitting a red light may indicate a replacement wear state. The listed color choices are merely representative and other colors and/or combinations of colors may be contemplated. In some cases, the user interface **450** may be configured to illuminate a different number of LEDs **452** and/or a pattern of LEDs **452** to indicate one or more particular wear state conditions of the brush **24** and/or the rotating component **15**. In some cases, a reflective surface (e.g., the polished brush box of the brush holder **22**, a separate reflector, etc.) may be used to direct and/or amplify light emitted by the one or more LEDs.

In some cases, the wear state of the brush **24** and/or rotating component **15** may be indicated by the user interface **450** via the speaker **456**. The speaker **456** may be used to emit an audible indication, such as a specified tone for a specified duration, for one or more wear states of the brush **24** and/or the rotating component **15**.

In some cases, the user interface **450** may include one or more components to allow a user to input information about the wear state monitor **50** (e.g., a communication address, an installed location, etc.), information about the flexible sensor **60** and/or brush holder assembly **110** (e.g., calibration information, threshold information, etc.), or other information about the brush monitoring system **100**. For example, the user interface **450** may include one or more switches **454** that may be used to assign a communication address or other identification information, to a particular wear state monitor **50**, assign a communication channel and/or frequency for communication via the communication link **115**, specifying a monitoring schedule, and/or adjust a threshold by, for

example, adding and/or removing a resistor network to adjust a voltage divider network. For example, a user interface **450** may include one or more groups of switches **454**, where a first portion of switches **454** may be used to assign a site address, a second portion of the switches **454** may be used to assign an electrical machine number and a third portion of the switches **454** may be used to assign a brush assembly number or identify a location of the brush assembly **110**. In some cases, the user interface **450** may include one or more potentiometers and/or variable resistors that may be used to adjust a threshold, such as during a configuration process. These user interface components are merely illustrative and other components may be contemplated.

In some cases, user interface **450** may include a display **458** and one or more buttons **459** for entering information, such as by navigating one or more menu options. The display **458** may be any suitable display. In some instances, a display **458** may include or may be a liquid crystal display (LCD), and in some cases a fixed segment display or a dot matrix LCD display. If desired, user interface **450** may be a touch screen LCD panel that may operate both display **458** and data entry functions. In some instances, the display **458** may be adapted to solicit values for a number of operating parameters and/or to receive such values, but this is not required. In some cases, the user may be capable of entering at least a portion of the identification information (e.g., a site number, a machine number, a brush assembly number) using the touch screen display, the keyboard, the buttons **459** or other means of inputting the numerical and/or textual information.

In many cases, when a diagnostic limit, such as a predetermined threshold, has been violated, the processor **440** may be configured to indicate to the user that a diagnostic fault has occurred. This may be accomplished in any of a variety of ways. For example, if the processor **440** has determined that a diagnostic limit has been violated, and a diagnostic fault has occurred, the processor **440** may cause a user alert to be indicated by the user interface **450**. In some cases, the processor **440** may process instructions to alert the user to a particular wear state only after a predetermined number of threshold violations and/or that a threshold violation exceeds a particular duration are detected by the processor **440**. For example, the processor **440** may be programmed to indicate a wear state of the brush **24** after a particular threshold value has been met for at least a predetermined threshold (e.g., 5 seconds, 30 seconds, 1 minute, etc.). Similarly, the processor **440** may be programmed to indicate a wear state of the rotating component **15** after a particular threshold (e.g., a replacement threshold) has been exceeded for a specified number of times (e.g., ten times, fifteen times, etc.) within a particular duration (e.g., 30 seconds, 1 minute, etc.) and/or a specified number of revolutions of the rotating component (e.g., 10 revolutions, 20 revolutions, etc.). In some cases, the user alert may be an audible tone from the speaker **456** and/or a simple text string displayed on a display of the user interface **450** which may describe the nature of the violation that has occurred. In other instances, the processor **440** may provide some visual indication to alert the user that a fault has occurred. Such visual indication may include a colored, flashing or otherwise visible indication provided on the user interface **450**. In still other instances, the processor **440** may be configured to provide information to another device, such as the site monitor **120** or the remote monitoring device **150**, **160**. One or more of the site monitor **120** or the remote monitoring device **150**, **160** may provide the information to a user via

a visual indication, an audible indication, an email, an instant message, a text message or some other message to a user to alert the user of the wear state of the one or more components of the brush holder assembly **110**. Such information may be provided via an internet gateway **170** or other device that is adapted to communicate over the internet or other wide area network, a local area network, and the like. For example, the internet gateway **170** may be configured to communicate with the network **130**, and/or an industrial control system. Such an alert may be provided to the user even when the user is away from the site in which the brush monitoring system **100** is located.

In addition to the user interface **450**, the wear state monitor **50** may be capable of communicating information about the wear state of the brush **24** and/or the rotating component **15** to a user via the communication circuit **470**. The information about the wear state of the brush **24** and/or the rotating component **15** may be associated with information identifying one or more of a particular site, a particular electrical machine and/or a particular brush assembly associated with the brush **24** and/or the rotating component **15**. In some cases, the communication circuit **470** may include a communication port (e.g., a speaker **472**, a transceiver **474**, etc.) that may be used to communicate with the site monitor **120** via the communication link **115**. One or more communication protocols may be used by the wear state monitor **50** to communicate wear state information associated with the brush holder assembly **110** to the site monitor **120**. The communication circuit **470** may include a chipset capable of communicating via one or more communication link technologies such as by using audio energy (e.g. an ultrasonic signal), radio frequency (RF) energy (e.g., an RF signal), and/or light energy (e.g., an optical signal, an infrared (IR) signal, etc.), or the like. In some cases, the communication circuit **470** may be capable of communicating via one or more other wireless technologies such as Bluetooth™, Wi-Fi, Zigbee or any other wireless protocol. In some cases, the communication circuit **470** may be configured to communicate via one or more wired interfaces, but this is not required. For example, the communication circuit **470** may include a wired port such as a serial port, an ARCNET port, a parallel port, a serial port, a CATS port, a USB (universal serial bus) port, and/or the like. In some cases, the communication circuit **470** may use one or more communication protocols, such as Ethernet, BACNet, LONtalk, DeviceNet, ControlNet, Profibus, etc., that may be used via a wired network or a wireless network.

In some cases, as illustrated in FIG. 4, the wear state monitor **50** may optionally include a data port **490**. Data port **490** may be a wireless port such as a Bluetooth™ port or any other wireless protocol. In other cases, data port **490** may be a wired port such as a serial port, a parallel port, a CATS port, a USB (universal serial bus) port, and/or the like. In some instances, data port **490** may be a USB port and may be used to download and/or upload information from a USB flash drive or some other data source. Other remote devices may also be employed, as desired. The data port **490** may be configured to communicate with processor **440** and may, if desired, be used to upload information to processor **440** and/or download information from the processor **440**. Information that can be uploaded and/or downloaded may include, for example, values of thresholds and/or timing information. In some instances, the data port **490** may be used to upload previously-created configuration information of the wear state monitor **50** and/or the flexible sensor **60**, thereby hastening the configuration process. In some cases, data port **490** may be used to download a configuration that

has been created using a particular wear state monitor **50** and/or flexible sensor **60** so that the configuration may be transferred to other similar wear state monitors **50**, hastening their programming process. In some cases, the data port **490** may be used to upload and/or download information pertaining to wear state trends of the brush **24** and/or the rotating component **15**, if desired.

In some cases, data port **490** may be used to download data stored within the memory **480** for analysis. For example, data port **490** may be used to download a wear state log associated with the brush **24** and/or the rotating component or parts thereof to a removable device such as a USB memory stick (also sometimes referred to as a thumb drive or jump drive), personal computer, laptop, iPad® or other tablet computer, PDA, smart phone, or other remote device, as desired. In some cases, the data may be convertible to an MS EXCEL®, MS WORD®, text, XML, and/or Adobe PDF® file, but this is certainly not required.

In some cases, the wear state monitor **50** may include one or more environmental sensors capable of sensing characteristics of the environment near the brush holder assembly **110**. Examples of the environmental sensors may include a temperature sensor and/or a humidity sensor. The wear state monitor **50** may be configured to use the sensed environmental information when determining a threshold and/or may communicate the sensed environmental information to another device, such as the site monitor **120** or the remote monitoring device **150, 160**.

FIGS. **5A** and **5B** are perspective views of an illustrative flexible sensor **60** of FIGS. **1, 3, and 4**. The illustrative flexible sensor **60** may include a substrate **510**, at least one ink layer **520**, and two or more electrical connectors **530** that may be connected to one or more wires **540**. The flexible sensor **60** may be substantially flat and may be selected from a variety of lengths, widths and/or thicknesses. In some cases, the flexible sensor **60** may have a variable resistance that is designed to change as the flexible sensor **60** is bent. The flexible sensor **60** may be formed by depositing the one or more electrically conductive ink layers **520** onto a top surface **515** of the substrate **510**. For example, the substrate **510** may be formed from a flexible, electrically insulating material, such as a plastic film (e.g., a biaxially-oriented polyethylene terephthalate film, a polyimide film, a polyester film, a polyamide film, a phenolic resin etc.). The electrically conductive ink layers **520** may be adhered to the top surface **515** of the substrate **510** and may be formed from one or more electrically conductive inks (e.g., a carbon-based ink, a polymer based ink, a composite ink, and the like) and/or one or more other electrically conductive materials, such as an epoxy and/or an adhesive where the epoxy or adhesive includes a conductive material (e.g., graphite, carbon, etc.). In some cases, the electrically conductive ink layers **520** may be capable of forming micro-cracks as the substrate **510** is bent, where the size and or shape of the micro-cracks causes the electrical resistance of the flexible sensor **60** to change in a predictable manner. Examples of such a flexible sensor **60** may include the Bend Sensor® from Flexpoint Sensor Systems, Inc. of Draper Utah. Other examples of flexible sensors are disclosed in U.S. Pat. Nos. 7,248,142; 8,047,083; 7,277,004; and 5,157,372; each of which is incorporated herein by reference.

As discussed above, the flexible sensor **60** may have a variable resistance that is designed to change as the flexible sensor **60** is bent. The flexible sensor **60** may be connected to a wear state monitor **50** by an electrical connection, such as one or more terminals **530**, wires **540** or other such means to form an electrical connection. In some cases, the wires

540 may be shielded to reduce an amount electrical noise introduced into the circuitry of the wear state monitor **50** from the brush monitoring system **100**. For example, the wires **540** may be a twisted pair of wires **540** included in a cable having a shield **550**. In some cases, such as in FIG. **5B**, the electrical connectors **530** may be connected directly to one or more terminals **425** of the wear state monitor **50**.

The power source **460** (e.g., a battery) of the wear state monitor **50** may be used to supply power to one or more components of the wear state monitor **50** and/or the flexible sensor **60** to facilitate generation of a signal representative of a bending radius of the flexible sensor **60**. For example, the wear state monitor **50** and the flexible sensor **60** may operate together to form at least a portion of a voltage divider circuit to produce a voltage output that is a fraction of a power source voltage. By bending the flexible sensor **60** using a bending force, such as the force provided by the spring **29** to maintain physical contact between the brush **24** and the surface of the rotating component **15**, the bending force may cause a change in resistance of the flexible sensor **60**. The change in the resistance of the flexible sensor **60** may correspond to the physical position of a top surface **624** of the brush **24** in relation to the conductive surface **12** of the rotating component **15**. The variable resistance of the flexible sensor **60** may vary linearly or non-linearly corresponding to a degree of bending of the flexible sensor **60**. Similarly, the change in resistance of the flexible sensor **60** causes a corresponding change in the voltage output of the signal representative of the bend radius of the flexible sensor **60**.

Information about the bend radius of the flexible sensor **60** may be used to determine a wear state of the brush **24** and/or the condition of a rotating component **15** of the electrical machine (e.g., a slip ring). As mentioned above, the wear state monitor **50** may be electrically connected to the flexible sensor **60** by the wires **540**. The wear state monitor **50** may determine a wear state of the brush **24** and/or the rotating component **15** by comparing at least a portion of the signal representative of the bend radius of the flexible sensor **60** to one or more predetermined threshold values. In some cases, the wear state monitor **50** may be configured to include a first threshold value corresponding to a first wear state of the brush **24** and a second threshold value different from the first threshold value corresponding to a second wear state of the brush **24**. For example, the first threshold value may be a first voltage level associated with a brush wear state indicative of a wear state where the brush **24** should be replaced within a predetermined time period (e.g., within a week). The second threshold value may correspond to a wear state of the brush **24** indicative of a wear state requiring the brush **24** to be replaced as soon as possible.

In some cases, the wear state monitor **50** may be configured to monitor a vibration of the brush **24**. For example, a vibration of a brush **24** may be due to one or more imperfections or other deformation of the rotating component **15** of the electrical machine. For example, a slip ring may deform or may wear unevenly to cause one or more portions of the slip ring to be out of round. As the brush **24** encounters these defects at one or more positions during a revolution of the rotating component **15**, the defects may cause the brush **24** to vibrate at a rate corresponding to the rotation speed and/or the number of defects at the conductive surface **12** of the rotating component **15** (e.g., a slip ring, a commutator, etc.). In some cases, the wear state monitor **50** may be configured to include a third threshold value, different than the first and second threshold values, corresponding to a first

wear condition of the rotating component **15** of the electrical machine and a fourth threshold value, different than the first, second and third threshold values, corresponding to a second wear condition of the rotating component **15**. For example, the third threshold value may be a first voltage level associated with a condition of the rotating component **15** indicative of a wear state where the rotating component **15** should be replaced and/or repaired within a predetermined time period (e.g., within a week). The fourth threshold value may correspond to a condition of the rotating component **15** indicative of a condition where maintenance (e.g., replacement and/or repair) of the rotating component **15** should be completed as soon as possible.

FIGS. **6A** and **6B** show perspective views of an illustrative brush holder assembly **600**, such as the brush holder assembly **110** of FIG. **1**, at different identifiable wear states of the brush **24**. The wear state monitor **50** may be positioned within the coil **310** of the spring **29**. The flexible sensor **60** may be positioned adjacent to the spring **29** and electrically connected to the wear state monitor **50**. Here, this electrical connection is not shown to simplify the illustration. FIG. **6A** illustrates a first wear state of the brush **24**, such as an initial wear state of the brush **24** when the brush holder assembly **600** is first installed on an electrical machine. For example, when the brush holder assembly **600** is in an engaged position, the spring **29** applies a force to the top surface **624** of the brush **24** to engage the brush **24** with the conductive surface **12** of the rotating component **15**. The top surface **624** may be at a first position where the bending force of the spring **29** causes a first bend radius **610**. The first bend radius **610** may cause the flexible sensor **60** to have a first resistance value that may be associated with the initial wear state of the brush **24**. A second bend radius **640** may cause the flexible sensor **60** to have a second different resistance value that may be associated with a different wear state of the brush **24**, such as a wear state approaching a replacement wear state or a replacement wear state. The brush monitoring system **100** and/or components of the brush monitoring system (e.g., the wear state monitor **50**, the site monitor **120**, the remote monitoring devices **150**, **160**) may be calibrated to account for variations in geometry of the brush holder assembly and/or the brush, the differing forces applied by different springs, and/or for other factors that may change between different brush holder assemblies **110**. In some cases, the wear state monitor **50** may be resiliently mounted within the coil of the brush **24**, such that vibrations of the brush **24** may be absorbed and/or dampened.

The resistance value of the flexible sensor **60** at the different bend radiuses may be caused by a series of micro-cracks **665** formed within the ink layer **520** that may form as the flexible sensor **60** bends. The micro-cracks **665** may form due to cracking of a brittle component of the ink layer **520**, while a flexible component may maintain the overall integrity of the ink layer **520**. The micro-cracks **665** in the ink layer **520** cause the electrical resistance of the flexible sensor **60** to change. As a bend radius decreases due to the applied bending force, more micro-cracks **665** form in the ink layer **520** causing the resistance of the flexible sensor **60** to increase. The resistance can vary based on the magnitude of bending force applied to the flexible sensor **60**, the amount of wear of the brush **24** and/or the movement of the brush **24**. The wear state monitor **50** may receive a variable voltage signal from the flexible sensor **60** based on the variable resistance of the flexible sensor **60** due to movement over a duration of interest. A smaller radius of curvature may correspond to a larger resistance value of the

flexible sensor **60**. For example, the electrical resistance of the flexible sensor **60** at the first bend radius **610** is less than the electrical resistance of the flexible sensor **60** at the second bend radius **640**. The flexible sensor **60** may be repeatedly bent because the ink layer **520** continues to have a strong bond to the substrate **510**. The resistance of the flexible sensor **60** returns to the first resistance value when the flexible sensor **60** returns to the first bend radius **610**.

The flexible sensor **60** may be installed within the brush holder assembly **110** such that a proximal end **661** including the electrical connections, such as terminals **530**, may be oriented toward the wear state monitor **50** and a distal end **661** may be oriented away from the wear state monitor **50**. In the example of FIG. **6A**, at the initial wear state of the brush **24**, at least a portion of the flexible sensor **60** including the distal end is oriented along a first plane **620** and another portion of the flexible sensor including the proximal end is oriented along a second plane **630**, where the deflection **615** between the first plane **620** and the second plane **630** corresponds to the first bend radius **610**. In FIG. **6B**, the brush **24** is shown at a second wear state such that the top surface **624** is at a different second position **651** at a deflection distance **655** from the initial wear state position **605**. At this second position **651**, at least a portion of the flexible sensor **60** including the distal end **661** is now oriented along a third plane **650** and another portion of the flexible sensor **60** including the proximal end **662** is oriented along a third plane **650**, where the deflection **645** between the third plane **650** and the second plane **630** corresponds to the second bend radius **640**.

FIG. **7** is a block diagram representation of a brush monitoring system **700** having an illustrative site monitor **720**, such as the site monitor **120**. At a facility, one or more electrical machines **710** may be configured to include one or more brush holder assemblies **715**, such as the brush holder assembly **110**. The brush holder assemblies **715** may be positioned around a rotating portion **730** (e.g. a shaft) of an electrical machine (e.g., a motor, a generator, etc.). The brush holder assemblies **715** may be positioned such that a brush **24** contacts a surface of a rotating component (e.g., a slip ring, a commutator) associated with the rotating portion **730** of the electrical machine. In some cases, the brush holder assemblies **715** may be mounted to a portion of the electrical machine using one or more adapters **726** that include the mounting beam **26** of FIGS. **1** and **3**. Each of the brush holder assemblies **715** may be configured to communicate to the site monitor **720** via a communication link **115**.

The site monitor **720** may include a communication circuit **740**, a processor **750**, a memory **760**, an I/O block **770**, a data port **780**, a user interface **790**, and/or one or more sensors **795**. In some cases, the communication circuit **740** may include a signal conditioning circuit **741** that may be used to filter and/or otherwise condition the signal received from the one or more brush holder assemblies **715**. The site monitor **720** may include a power source **792**, such as a battery, a capacitor, and/or a power line adapter. In some cases, the battery may be rechargeable and/or replaceable. In some cases, the site monitor **720** may include an energy harvesting capability, such that the power source **792** may receive energy and/or may be recharged by one or more energy harvesting technologies. For example, illustrative energy harvesting technologies may include a kinetic (e.g., vibrational) energy harvester (e.g., a piezoelectric vibration energy harvester, a magneto-inductive vibration energy harvester, etc.), a photovoltaic energy harvester capable of harvesting energy indoors and/or outdoors, a piezoelectric energy harvester, a thermal energy harvester, a wind energy

(e.g., microturbine) harvester, and/or an ambient radiation (e.g. radio frequency) energy harvester.

The communication circuit **740** may be capable of receiving information about the wear state of the brush **24** and/or the rotating component (e.g. a slip ring, a commutator, etc.) associated with the rotating portion **730** of the electrical machine from one or more wear state monitors (e.g., the wear state monitor **50**) associated with the brush holder assemblies **715** and/or communicating configuration and/or timing information to the one or more wear state monitors **50**. In some cases, the communication circuit **740** may include a communication port (e.g., an audio receiver/transmitter **742**, an RF transceiver **744**, etc.) that may be used to communicate with the wear state monitor **50** via the communication link **115**. One or more communication protocols may be used for communication between the wear state monitors **50** of the brush holder assemblies **715** and the site monitor **720**. The communication circuit **740** may include a chipset capable of communicating via one or more communication link technologies such as by using audio energy (e.g. an ultrasonic signal), radio frequency (RF) energy (e.g., an RF signal), and/or light energy (e.g., an optical signal, an infrared (IR) signal, etc.), or the like. In some cases, the communication circuit **740** may be capable of communicating via one or more other wireless technologies such as Bluetooth™, Wi-Fi, Zigbee or any other wireless protocol. In some cases, the communication circuit **740** may be configured to communicate via one or more wired interfaces, but this is not required. For example, the communication circuit **740** may include a wired port such as a serial port, an ARCNET port, a parallel port, a serial port, a CATS port, a USB (universal serial bus) port, and/or the like. In some cases, the communication circuit **740** may use one or more communication protocols, such as Ethernet, BACNet, LONtalk, DeviceNet, Profibus, ControlNet, etc., that may be used via a wired network or a wireless network. For example, the communication circuit **740** may be configured to communicate via one or more communication links **125**, **127**, **135**, and **137**, such as via the network **130**, to a remote monitoring device **150**, **160** at a remote site at a different geographical location than the site monitor **720**, such as the remote monitoring site **140**. In some cases, the communication circuit **740** may be configured to communicate to an industrial controller (e.g., a programmable logic controller) to provide wear state information about one or more brush assemblies **715** to a user.

In some cases, each of the one or more brush assemblies **715** may be assigned a unique identifier, such as a communication address, to facilitate communication with one or more of the site monitor **720** and the remote monitoring device **150**, **160**. Each unique identifier may allow the site monitor **720** and/or the remote monitoring device **150**, **160** to associate received wear state information with a particular brush assembly and/or portion of the rotating component **15** of a particular electrical machine. These identifiers may use one or more naming conventions, as desired by a user. For example, the identifier may use an alphanumeric naming convention (e.g., brushassembly14, em1.ba10, machine1.row1.colum3, sitea.machine1.ba3, etc.), a numerical naming convention (e.g., 1,2, 1.2.4, etc.), or an encoded naming convention (e.g., 0x0145CDEF, 11000, etc.).

In some cases, the identifiers may be used to identify a particular brush assembly individually, (e.g., brushassembly24, 24, 0x18, 11000, etc.). The identifiers may also be used to associate the particular brush assembly with a particular electrical machine and/or a particular site (e.g.,

site1_machine3_brushassembly12, 1.3.12, 0x0111000C, 0111 00001100, etc.). The wear state monitor **50** may be configured to store the identifier as a character string or as a numerically encoded value. For example, an alphanumeric identifier using an alphanumeric naming convention may be stored and/or communicated as a character string. Identifiers using a numerical naming convention or an encoded naming convention may be stored as one or more numbers (e.g., integers, etc.) that may be communicated as one or more integer values. In some cases, the identifier may be encoded into a single integer value (e.g., a hexadecimal encoded value, a binary encoded value, etc.). By using an encoded naming convention, the identification information may be communicated as, for example, an integer value to minimize communication time. By minimizing communication time, energy usage may be reduced to extend the usable lifetime of the power source **460** of the wear state monitor, the power source **792** of the site monitor, or both.

Identification information may be encoded and stored in and/or transferred to a memory device such as, but not limited to, RAM, EPROM, EEPROM, flash memory, a hard drive, and/or the like. As an example, a 16-bit word may be used to encode identification information, such that a first portion of the 16-bit word (e.g., the four most significant bits, such as 0xSSSS_mmmmbbbbbbbb) may be used to identify a particular site, a second portion of the 16-bit word may be used to identify a particular electrical machine at the particular site (e.g., 0xssss_MMMM_bbbbbbbb), and a third portion of the 16-bit word may be used to identify a particular brush assembly **715** associated with the particular electrical machine (e.g., 0xssss_mmmm_BBBBBBBB). In this illustrative example, the brush monitoring system **700** may include up to sixteen sites that may be numbered between 0 and 15 (e.g., 0x0 to 0xF in hexadecimal, 0000 to 1111 in binary, etc.), up to sixteen electrical machines (e.g., numbered between 0 and 15, between 0x0 and 0xF in hexadecimal, between 0000 and 1111 in binary, etc.) associated to each site, and up to two hundred and fifty six brush assemblies **715** (e.g., numbered between 0 and 255, between 0x00 and 0xFF in hexadecimal, between 00000000 and 11111111 in binary) associated with each of the electrical machines. For example, a particular brush assembly **715** may be assigned an identifier of 0x3A04, which may be decoded by the site monitor **720** and/or the remote monitoring device **150**, **160** as the fourth brush assembly **715** on the tenth electrical machine at the third site. These naming conventions are merely illustrative and other such naming conventions may be used and/or contemplated for any particular user site and/or installation.

The site monitor **720** may include the user interface **790** for communicating with a user. For example, the user interface **790** may be any suitable user interface that permits the site monitor **720** to display and/or solicit information, as well as accept one or more user interactions with the site monitor **720**. For example, the user interface **790** may permit a user to enter data such as threshold values associated with particular wear states, time interval values, diagnostic limits, conditions under which diagnostic limits may be suspended, responses to alerts, and the like. In some cases, the user interface **790** may allow a user to enter information to facilitate the use of environmental data by the site monitor and/or the wear state monitors, such as temperature set points, humidity set points, and the like. These are just some examples.

The user interface **790** may provide diagnostic information about the machine, including the wear state information about brushes of the one or more brush holder assemblies

715 and/or the rotating components of the electrical machine, to a user via a visual indication, an audible indication, an email, an instant message, a text message or some other message to a user to alert the user of the wear state of the one or more components of the brush holder assembly 715. Such information may be provided via an internet gateway 170 or other device that is adapted to communicate over the internet or other wide area network, such as the network 130. Such an alert may be provided to the user even when the user is away from the site in which the brush monitoring system 100 is located, such as to the remote monitoring device 150, 160 at the remote monitoring site 140. In some cases, the user interface 790 may include a display and a distinct keypad. A display may be any suitable display. In some instances, a display may include or may be a liquid crystal display (LCD), and in some cases a fixed segment display or a dot matrix LCD display. If desired, user interface 790 may be a touch screen LCD panel that functions as both display and keypad. In some instances, a touch screen LCD panel may be adapted to solicit values for a number of operating parameters and/or to receive such values, but this is not required. In some cases, the I/O block 770 of the site monitor 720 may include an interface for connecting one or more user interface devices, such as an external display, a keyboard, a pointing device (e.g., a mouse, a trackball, etc.).

In some cases, the processor 750 may be configured to process wear state information about a rotating component of the electrical machine 710 received from the wear state monitors associated with the one or more brush holder assemblies 715. For example, the processor 750 may operate using an algorithm for processing wear state information received from the brush assemblies 715 to monitor the wear state information of the one or more brushes and/or the rotating component 15 associated with the rotating portion 730 of the electrical machine. For example, the processor 750 may be capable of predicting a usable lifetime remaining for each brush 24 by monitoring the received information over time. In some cases, the processor 750 may process instructions to store the received wear state information into the memory 760. For example, each of the one or more brush holder assemblies 710 may be associated with a particular memory block 762, 764 for storing information about the particular brush holder assembly 715.

The processor 750 may use the stored wear state information, along with any new wear state information, to determine diagnostic information about the electrical machine 710. For example, trend information and/or environmental information received from the brush holder assemblies 715 may be used to determine whether one or more of the brush holder assemblies 715, the rotating component 15 and/or the rotating portion 730 may be misaligned, with respect to one or more of the other components of the electrical machine. In some cases, the site monitor 720 may include one or more sensors 795, such as environmental sensors (e.g., a temperature sensor, a humidity sensor, etc.), and/or an I/O block 770 that may include one or more wire terminals for receiving information from one or more environmental sensors to provide environmental information (e.g., a temperature, a humidity, etc.) about the environment at the site. Such information may be helpful in determining trends and/or performing other diagnostic analysis on the electrical machine.

The processor 750 may be programmed to receive wear state information from the one or more brush holder assemblies 715 at predetermined intervals. In some cases, the predetermined intervals may be fixed at a particular value

(e.g., once per day, once per week, etc.) and in other cases, the intervals may change after a particular wear state has been reached. For example, the processor 750 may be configured to receive wear state information from the brush holder assemblies 715 at a first time interval, such as once per day, until one or more brushes and/or the rotating component 15 reach a wear state approaching the replacement wear state. At that point, the processor 750 may sample the wear state information from the brush holder assemblies 715 at a second shorter time interval, such as hourly. In some cases, the processor 750 may include a timer 752 and/or may be communicatively coupled to a timer circuit.

In some cases, the site monitor 720 may receive information about the flexible sensors 60 included in the one or more brush holder assemblies 715. For example, the wear state monitors of the brush holder assemblies 715 may not include processing capability to determine a wear state indication of the brush 24 and/or the rotating component 15. As such, the processor 750 of the site monitor 720 may be programmed to determine a wear state of at least one of the brush 24 and the rotating component 15 using information received from one or more flexible sensors 60 of the brush holder assemblies 715. The processor 750 may, for example, operate using an algorithm that causes the communication circuit 740 to obtain information corresponding to a bend radius of the flexible sensor 60 of a particular brush holder assembly 715 continuously or at predetermined intervals. The processor 750 may then compare the received information to one or more predetermined threshold values to determine a wear state indication for the brush 24 and/or the rotating component 15.

The memory 760 of the illustrative site monitor 720 may be in communication with the processor 750. The memory 760 may be used to store any desired information, such as the aforementioned control algorithm, threshold values, schedule times, sampling times, trending information, and the like. As mentioned above, each of the one or more brush holder assemblies 715 may be associated with a particular memory block 762, 764 for storing information about the particular brush holder assembly 715. The memory 760 may be any suitable type of storage device including, but not limited to, RAM, EPROM, EEPROM, flash memory, a hard drive, and/or the like. In some cases, the processor 750 may store information within the memory 760, and may subsequently retrieve the stored information.

In some cases, the site monitor 720 may optionally include a data port 780. The data port 780 may be a wireless port such as a Bluetooth™ port or any other wireless protocol. In other cases, data port 780 may be a wired port such as a serial port, a parallel port, a CATS port, a USB (universal serial bus) port, and/or the like. In some instances, data port 780 may be a USB port and may be used to download and/or upload information from a USB flash drive or some other data source. Other remote devices may also be employed, as desired. The data port 780 may be configured to communicate with processor 750 and may, if desired, be used to upload information to processor 750 and/or download information from the processor 750. Information that can be uploaded and/or downloaded may include, for example, values of thresholds and/or timing information. In some instances, the data port 780 may be used to upload previously-created configuration information of a particular electrical machine 710 and/or a particular brush holder assembly 715, such as the wear state monitor 50 and/or the flexible sensor 60, thereby hastening the configuration process. In some cases, data port 780 may be used to download a configuration that has been created using a particular wear

state monitor **50** and/or flexible sensor **60** so that the configuration may be transferred to other similar wear state monitors **50**, hastening their programming process. In some cases, the data port **780** may be used to upload and/or download information pertaining to wear state trends of the brush **24** and/or the rotating component **15**, if desired.

In some cases, data port **780** may be used to download data stored within the memory **760** for analysis. For example, data port **780** may be used to download a wear state log associated with one or more brushes and/or rotating components to a removable device such as a USB memory stick (also sometimes referred to as a thumb drive or jump drive), personal computer, laptop, iPad® or other tablet computer, PDA, smart phone, or other remote device, as desired. In some cases, the data may be convertible to an MS EXCEL®, MS WORD®, text, XML, and/or Adobe PDF® file, but this is certainly not required.

FIG. **8** illustrates an exemplary bus of mounting blocks and brush holder assemblies **810a-d** of an electrical machine utilizing different configurations of the wear state monitor **812a-d** and the flexible sensor **815a-d**. In some cases, one or more brush holder assemblies **810a-d** may be mounted onto the electrical machine by mounting the brush holder assemblies **810a-d** on mounting blocks secured to a stationary member **34**. For example, a first brush holder assembly **810a** may be mounted onto a first mounting block, a second brush holder assembly **810b** may be mounted onto a second mounting block, a third brush holder assembly **810c** may be mounted onto a third mounting block, and a fourth brush holder assembly **810d** may be mounted onto a fourth mounting block, etc.

When the brush holder assemblies **810a-d** are moved to the engaged position (such as shown in FIGS. **3**, **5A**, and **5B**) in which the electrical connection is established through the brush **824a-d**, a terminal and a mounting block to/from the conductive surface **12**, the wear state monitors **812a-d** may be positioned in an initial wear state position. At some later point in time, after the brush holder assembly **810a-d** has been installed on the electrical device and used, such as when a brush **824a-d** has worn sufficiently to warrant replacement, when an anomaly or threshold condition has occurred, or otherwise when maintenance needs to be performed on the electrical device, the brush holder assembly **810a-d** and/or the brush **824a-d** of the brush holder assembly **810a-d** may be removed from the mounting block and replaced with a new brush holder assembly **810a-d** and/or brush **824a-d**.

In some cases, the wear state monitor **812a-d** and/or the flexible sensor **815a-d** may be configured differently. For example, the wear state monitor **812a** and **812d** may include a slot-like opening, such as the opening **225** of FIG. **2**. In such cases, the electrical connections of the flexible sensors **815a**, **815d** may be connected internally to the wear state monitor **812a**, **812d**. In such cases, the flexible sensor **815a** may be affixed to the spring using an adhesive and may be coated with a coating, such as Teflon, to protect the flexible sensor **815a** from wear. In another example, the wear state monitor **812d** may be configured to extend beyond the edge of the spring **829d** such that the flexible sensor **815d** may be positioned adjacent to the edge of spring **829d**. In other examples, the flexible sensor **815b**, **815c** may include one or more wired connections that may be connected to the wear state monitor **812b**, **812d**. In the illustrative example of FIG. **8**, the wear state monitor **812b** may include two terminals on the same end of the wear state monitor **812b**. However, the wear state monitor **812c** may include a terminal on each end

of the wear state monitor **812b**. These configurations are merely illustrative and other such configurations may be used and/or contemplated.

FIG. **9** shows a graph **900** of an illustrative voltage associated with the variable resistance of the flexible sensor **60** associated with the wear state of a brush **24** over time. As mentioned above, the flexible sensor **60** may have a variable resistance that may vary based on a bending radius applied to the flexible sensor **60**. For example, if the bending radius of the flexible sensor **60** increases, then the variable resistance value of the flexible sensor **60** would increase accordingly, according to a characteristic curve of the particular flexible sensor. As such, when the flexible sensor **60** is incorporated into an electrical circuit, such as a voltage divider circuit, the voltage output from the voltage divider circuit may vary accordingly, as shown as the curve **910**. In an example, an initial variable resistance value **905** may be determined when a particular flexible sensor **60** is incorporated in a brush assembly **110** that is in an engaged position. Over time, as the associated brush **24** wears, the bending radius of the flexible sensor **60** will increase. In this particular voltage divider configuration, the voltage increases. In some cases, at least two threshold voltages may be defined for monitoring the wear state of the brush **24**. For example, the first threshold value, V_m **920**, may be associated with a wear state approaching a replacement wear state and the second threshold value, V_r **930**, may be associated with the replacement wear state. In some cases, at the time **940**, an associated wear state monitor may indicate to a user that the brush **24** has reached a wear state approaching the replacement wear state. At time **950**, the associated wear state monitor may indicate to a user that the brush **24** has reached the replacement wear state.

FIG. **10** shows a graph **1000** of an example of a transient voltage signal **1010** illustrative of a condition of a rotating component **15** of an electrical machine. In some cases, the transient voltage signal **1010** may operate under a shorter time scale than the steady state signal. For example, the wear state monitor **50** may monitor one or more transient events occurring within a single revolution and/or over one or more revolutions of the rotating component **15**. For example, the time **1015** may correspond to a time of a single revolution. For a rotating component **15** rotating at about 1000 revolutions per minute, a single revolution may occur about every 0.06 seconds. In some cases, the wear state monitor **50** may monitor transient events over multiple revolutions (e.g., two revolutions, five revolutions, ten revolutions, etc.). The transient events **1025** may be correspond to a vibration of the brush, such as when the brush **24** encounters irregularities on the surface of the rotating component **15**. In some cases, two or more threshold values may be defined, such as V_{mt} **1020** and V_{rt} **1030**, where V_{mt} **1020** corresponds to a wear state when the rotating component **15** is approaching the replacement wear state and V_{rt} **1030** may correspond to a replacement wear state of the rotating component **15**. As can be seen, the transient event **1035** has crossed the V_{rt} **1030** threshold value. In such cases, the wear state monitor may indicate that the rotating component has reached the replacement wear state. In other cases, the wear state monitor may indicate that the rotating component has reached the replacement wear state after V_{rt} has been reached a specified number of times and/or for a specified duration. These are just some examples.

In some cases, some vibration having a small magnitude (e.g., about 0.002 inches, about 0.003 inches, etc.) of the brush may be present during normal operation. As the rotating component **15** wears, the magnitude of the vibration

may change. By monitoring the magnitude of the signal representative of the vibration (e.g., the transient voltage signal **1010**), the wear state of the rotating component may be inferred. For example, during normal operation vibration having a magnitude of approximately 0.005 inches or less may be considered "acceptable". As shown in FIG. **10**, three wear state conditions may be inferred by monitoring the transient voltage signal **1010**. For example, a first area **1040** may correspond to an "operational" wear state (e.g., vibration magnitude < about 0.005 inches), a second area **1050** corresponding to a wear state approaching a replacement wear state (e.g., a vibration magnitude between about 0.005 inches and about 0.010 inches, and a third area **1060** corresponding to a replacement wear state (e.g., a vibration magnitude > about 0.10 inches) may be defined using thresholds **1020**, **1030**.

FIG. **11** shows an illustrative method **1100** for monitoring a wear state of one or more components of an electrical device. At **1110**, a wear state monitor may obtain a variable value from a flexible sensor, such as a variable resistance value, a variable voltage value and/or a variable current value. The variable voltage value and/or the variable current value may be associated with the variable resistance value of the flexible sensor. The variable value may be used to sense the movement of a carbon brush in relation to a rotating component of an electrical device, such as a slip ring of the electrical machine of FIG. **7**. For example, the variable resistance may correspond to a bend radius of the flexible sensor **60** associated with the brush **24** and spring **29** of the brush holder assembly **110**. Variations in bend radius may be associated with the movement of a brush and or a wear state of the brush in relation to the rotating component of the electrical device. At **1120**, the variable resistance value may be compared to a threshold value to determine a wear state of the brush. The wear state of the brush may be communicated to a user, such as by a user interface that may include a visible indicator and/or an audible indicator.

In some cases, at **1130** the indication of the wear state of the brush may be communicated to a site monitoring device and/or a remote monitoring device. The remote monitoring device may be located at the same and/or at a different geographical location from the geographical location of the electrical machine and the site monitoring device.

In some cases, the wear monitor, the site monitor and/or the remote monitoring device may include a processor capable of processing instructions for predicting a life expectancy of the brush and/or the rotating component of the electrical machine using the resistance value associated with the movement of the carbon brush. In some cases, the processor may be capable of processing instructions for identifying the wear state of the carbon brush using a steady state variable resistance value and/or identifying the wear state of the rotating electrical component (e.g., a slip ring, a commutator, etc.) of the electrical device using a transient variable resistance value.

Those skilled in the art will recognize that aspects of the present disclosure may be manifested in a variety of forms other than the specific embodiments described and contemplated herein. Accordingly, departure in form and detail may be made without departing from the scope and spirit of the present disclosure as described in the appended claims.

What is claimed is:

1. A monitoring apparatus for monitoring a carbon brush of a brush holder assembly of an electrical machine, the apparatus comprising:

a sensor configured to move with a spring of the brush holder assembly, the sensor having an output that

varies [as a shape of the sensor varies, wherein the shape of the sensor changes] in response to movement of the carbon brush in relation to a rotating component of the electrical machine; and

a signal processing circuit coupled to the sensor to receive the output, the signal processing circuit configured for determining a measure of a wear state of the carbon brush using output of the sensor,

wherein the signal processing circuit is positionable within a coiled portion of the spring.

2. The monitoring apparatus of claim **[1]** **21**, wherein the sensor has a first shape upon initial installation of the carbon brush in the electrical machine and a second shape after a particular amount of wear to the carbon brush.

3. The monitoring apparatus of claim **1**, wherein the movement of the carbon brush is indicative of the wear state of the carbon brush and the sensor may be aligned along a plane after a particular amount of wear to the carbon brush.

4. The monitoring apparatus of claim **[1]** **21**, wherein the shape of the sensor that varies is a radius of curvature of the sensor that changes in response to movement of the carbon brush in relation to a rotating component of the electrical machine.

5. The monitoring apparatus of claim **4**, wherein the sensor has a first radius of curvature upon initial installation of the carbon brush in the electrical machine and a second radius of curvature after a particular amount of wear to the carbon brush.

6. The monitoring apparatus of claim **4**, wherein the output is a voltage output.

7. The monitoring apparatus of claim **6**, wherein the voltage output varies as the radius of curvature of the sensor varies.

8. The monitoring apparatus of claim **[1]** **21**, wherein the sensor includes a flexible resistor and the output of the sensor varies in response to an electrical resistance of the flexible resistor changing due, at least in part, to changes in the shape of the sensor.

9. The monitoring apparatus of claim **1**, wherein the signal processing circuit determines the measure of the wear state of the carbon brush by comparing the output of the sensor to at least one predetermined threshold value.

10. The monitoring apparatus of claim **9**, wherein the at least one predetermined threshold value corresponds to a steady state measure of the output of the sensor.

11. The monitoring apparatus of claim **1**, wherein the signal processing circuit determines the measure of the wear state of the carbon brush by comparing the output of the sensor to a first threshold value and determines a measure of a wear state of the rotating component of the electrical machine by comparing the output of the sensor to a second threshold value.

12. A brush holder assembly, the assembly comprising:
a brush holder for receiving and positioning a carbon brush in relation to a rotating component of an electrical machine;

a spring mounted to the brush holder, the spring for providing a force to a carbon brush received in the brush holder such that the carbon brush engages the rotating component of the electrical machine;

a sensor [positioned between the spring and the brush holder, the sensor] having an output that varies [as a shape of the sensor varies, wherein the shape of the sensor is representative of] based on a physical position and/or movement of a carbon brush received in the brush holder; and

a wear state monitor in electrical communication with the sensor, *the wear state monitor positioned within a coiled portion of the spring*, the wear state monitor for determining a measure of a wear state of the carbon brush using the output of the sensor.

13. The assembly of claim 12, wherein the brush holder includes a mounting beam and the sensor is positioned between the mounting beam and the spring.

14. The assembly of claim [12] 22, wherein the shape of the sensor that varies is a radius of curvature of the sensor that changes in response to movement of the carbon brush in relation to a rotating component of the electrical machine.

15. The assembly of claim 14, wherein the output is a voltage output.

16. The assembly of claim 15, wherein the voltage output varies as the radius of curvature of the sensor varies.

17. The assembly of claim [12] 22, wherein the sensor includes a flexible resistor and the output of the sensor varies in response to an electrical resistance of the flexible resistor changing due, at least in part, to changes in the shape of the sensor.

18. The assembly of claim 12, wherein the wear state monitor is further configured to determine a wear state of the rotating component of the electrical machine using the output of the sensor.

19. A brush holder assembly having an integral sensor for monitoring a wear state of a carbon brush or a rotating component of an electrical machine, the brush holder assembly comprising:

- a brush holder having a mounting beam;
- a carbon brush positioned in the brush holder;
- a spring coupled to the brush holder, the spring for providing a force to engage the carbon brush with a rotating component of the electrical machine;
- a sensor positioned between the spring and the mounting beam, the sensor having an output that changes as a change in radius of curvature of the sensor changes;
- an indicator for providing an indication of the wear state of at least one of the carbon brush and the rotating component of the electrical machine based, at least in part, on the output of the sensor.

20. The brush holder assembly of claim 19, further comprising:

- a communication circuit, the communication circuit configured to communicate information about the wear state of at least one of the carbon brush and the rotating component of the electrical machine to a site monitor proximate to the electrical machine.

21. *The monitoring apparatus of claim 1, wherein the output of the sensor varies as a shape of the sensor varies, wherein the shape of the sensor changes in response to movement of the carbon brush.*

22. *The brush holder assembly of claim 12, wherein the output of the sensor varies as a shape of the sensor varies, wherein the shape of the sensor changes in response to movement of the carbon brush.*

23. *A monitoring apparatus having a sensor for monitoring a wear state of a carbon brush of a brush holder assembly of an electrical machine, the monitoring apparatus comprising:*

- a sensor attachable to a spring of the brush holder assembly, wherein the sensor is configured to move with the spring;*
- a wear state monitor positionable within a coiled portion of the spring, wherein the wear state monitor is communicatively coupled to the sensor to obtain information about the wear state of the carbon brush based on movement of the spring; and*
- a power source disposed within the coiled portion of the spring to provide power to the wear state monitor.*

24. *The monitoring apparatus of claim 23, wherein the wear state monitor includes a cylindrical body designed to be captured within the coiled portion of the spring.*

25. *The monitoring apparatus of claim 24, wherein the wear state monitor includes one or more ribs used to ensure the wear state monitor remains mounted within the coiled portion of the spring.*

26. *The monitoring apparatus of claim 23, wherein the wear state monitor includes a communication circuit, the communication circuit for communicating information about a wear state of the carbon brush.*

27. *The monitoring apparatus of claim 26, wherein the communication circuit is capable of communicating via one or more wireless technologies.*

28. *The monitoring apparatus of claim 27, wherein the communication circuit is configured to wirelessly communicate the wear state of the carbon brush to a site monitor proximate to the electrical machine.*

29. *The monitoring apparatus of claim 23, wherein the wear state monitor includes a temperature sensor.*

30. *The monitoring apparatus of claim 23, wherein the wear state monitor is configured to identify a characteristic of a vibration of the carbon brush.*

31. *The monitoring apparatus of claim 23, wherein the wear state monitor includes an energy harvester.*

32. *A system for monitoring a wear state of a carbon brush of a brush holder assembly mounted on an electrical machine, the system comprising:*

- a wear state monitor positionable within a coiled portion of a spring urging the carbon brush into engagement with a rotating component of the electrical machine; and*
- a site monitor configured to receive a signal from the wear state monitor indicative of a wear state of the carbon brush;*

wherein the wear state monitor includes a power source disposed within the coiled portion of the spring to provide power to the wear state monitor.

33. *The system of claim 32, wherein the wear state monitor is communicatively coupled to a sensor to obtain information about the wear state of the carbon brush.*

34. *The system of claim 32, wherein the site monitor is configured to receive the signal from the wear state monitor wirelessly.*

35. *The system of claim 32, wherein the wear state monitor is configured to monitor a vibration of the carbon brush and the site monitor is configured to notify a user of excess vibration of the carbon brush.*

36. *The system of claim 32, wherein the wear state monitor includes a temperature sensor and the site monitor is configured to notify a user of excess heating of the brush holder assembly.*

37. *The system of claim 32, wherein the wear state monitor includes an energy harvester.*

38. *A method for monitoring a wear state of a carbon brush of a brush holder assembly mounted on an electrical machine, the method comprising:*

- obtaining a signal from a sensor attached to a spring of the brush holder assembly, the spring urging the carbon brush into engagement with a rotating component of the electrical machine, wherein the signal is proportional to linear movement of the carbon brush relative to a brush holder of the brush holder assembly surrounding the carbon brush;*
- processing the signal with a wear state monitor positioned within the coiled portion of the spring to determine a wear state of the carbon brush, wherein the wear state monitor includes a power source disposed within the coiled portion of the spring to provide power to the wear state monitor; and*

33

communicating the wear state of the carbon brush to a site monitor in proximity to the electrical machine.

39. *The method of claim 38, further comprising: displaying an indication of the wear state of the carbon brush on a display of the site monitor.*

40. *The method of claim 38, further comprising: displaying a predicted life expectancy of the carbon brush on a display of the site monitor.*

41. *The method of claim 38, wherein the signal varies based on movement of the sensor with the spring.*

42. *The method of claim 38, further comprising: monitoring a vibration of the carbon brush with the wear state monitor.*

43. *The method of claim 38, wherein the wear state monitor includes an energy harvester.*

44. *A brush holder assembly for monitoring a wear state of a carbon brush of an electrical machine, the brush holder assembly comprising:*

a carbon brush;

a spring associated with the carbon brush, the spring applying a force to a top surface of the carbon brush to engage the carbon brush with a rotating component of the electrical machine; and

34

a wear state monitor positioned within a coiled portion of the spring;

wherein the wear state monitor includes a power source disposed within the coiled portion of the spring to provide power to the wear state monitor.

45. *The brush holder assembly of claim 44, wherein the wear state monitor includes a cylindrical body designed to be captured within the coiled portion of the spring.*

46. *The brush holder assembly of claim 44, wherein the wear state monitor includes a communication circuit, the communication circuit for communicating information about a wear state of the carbon brush.*

47. *The brush holder assembly of claim 44, wherein the wear state monitor includes one or more environmental sensors, wherein the one or more environmental sensors includes a temperature sensor.*

48. *The brush holder assembly of claim 44, wherein the wear state monitor is configured to identify a characteristic of a vibration of the carbon brush.*

49. *The brush holder assembly of claim 44, wherein the wear state monitor includes an energy harvester.*

* * * * *