

US00RE48738E

(19) **United States**
(12) **Reissued Patent**
Kwak et al.

(10) **Patent Number: US RE48,738 E**
(45) **Date of Reissued Patent: Sep. 14, 2021**

(54) **MOBILE TERMINAL**

(56) **References Cited**

(71) Applicant: **LG ELECTRONICS INC.**, Seoul (KR)
(72) Inventors: **Daeyong Kwak**, Paju (KR); **Sungjung Rho**, Seoul (KR); **Kangjae Jung**, Seoul (KR)
(73) Assignee: **LG ELECTRONICS INC.**, Seoul (KR)

U.S. PATENT DOCUMENTS

4,940,992 A 7/1990 Nguyen et al.
4,980,694 A * 12/1990 Hines 343/702
5,086,509 A * 2/1992 Inubushi et al. 455/575.8
5,557,293 A 9/1996 McCoy et al.
5,710,987 A * 1/1998 Paulick 455/575.7

(Continued)

FOREIGN PATENT DOCUMENTS

CN 1977425 A 6/1997
CN 1554137 12/2004

(Continued)

(21) Appl. No.: **16/025,691**

(22) Filed: **Jul. 2, 2018**

Related U.S. Patent Documents

Reissue of:

(64) Patent No.: **9,431,693**
Issued: **Aug. 30, 2016**
Appl. No.: **13/161,418**
Filed: **Jun. 15, 2011**

OTHER PUBLICATIONS

Chinese Office Action for Chinese Application No. 201110283371.1.

(Continued)

(30) **Foreign Application Priority Data**

Feb. 25, 2011 (KR) 10-2011-0017410

Primary Examiner — Linh M Nguyen
(74) *Attorney, Agent, or Firm* — Birch, Stewart, Kolasch & Birch, LLP

(51) **Int. Cl.**
H01Q 1/24 (2006.01)
H01Q 5/371 (2015.01)
H01Q 7/00 (2006.01)
(52) **U.S. Cl.**
CPC **H01Q 1/243** (2013.01); **H01Q 5/371** (2015.01); **H01Q 7/00** (2013.01)
(58) **Field of Classification Search**
CPC H01Q 1/243; H01Q 5/371; H01Q 7/00; H01Q 9/14; H01Q 9/42; H01Q 5/307; H01Q 5/35; H01Q 5/40

See application file for complete search history.

(57) **ABSTRACT**

Disclosed herein is a mobile terminal including a terminal body comprising a circuit board formed to process radio signals, a first and a second member configured to form an external appearance of the terminal and disposed to cover a lateral surface of the circuit board, a power feed connecting portion to allow the first member and the circuit board to be power feed connected, and a ground connecting portion to allow the first member and the circuit board to be ground connected. Accordingly, an electrical element and an antenna are disposed adjacent to each other, allowing the effective use of a space within the terminal.

25 Claims, 8 Drawing Sheets

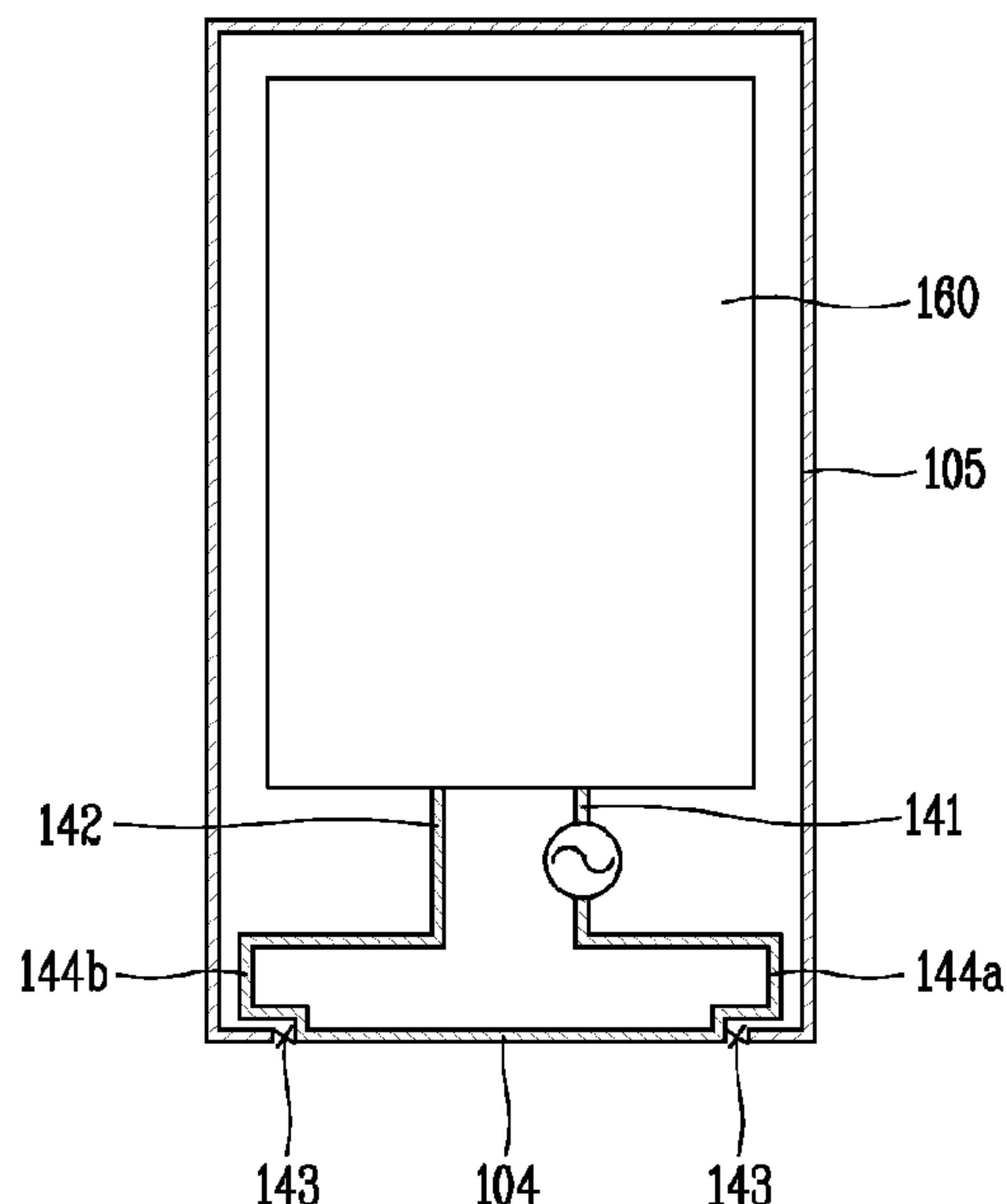

(56)

References Cited

U.S. PATENT DOCUMENTS

6,011,699 A * 1/2000 Murray et al. 361/814
 6,054,954 A * 4/2000 Eggleston et al. 343/700 MS
 6,218,990 B1 * 4/2001 Grangeat et al. 343/700 MS
 6,329,949 B1 * 12/2001 Barnett et al. 343/700 MS
 6,753,818 B2 * 6/2004 Wang 343/702
 6,940,460 B2 * 9/2005 Maoz et al. 343/702
 7,088,295 B2 * 8/2006 Komatsu et al. 343/713
 7,418,282 B2 * 8/2008 Nuovo et al. 455/575.8
 7,755,546 B2 * 7/2010 Ishimiya 343/702
 7,801,577 B2 * 9/2010 Lee 455/575.1
 8,138,980 B2 * 3/2012 Imano et al. 343/702
 8,140,136 B2 * 3/2012 Kim 455/575.4
 8,427,389 B2 * 4/2013 Sakashita et al. 343/878
 2004/0046701 A1 * 3/2004 Huber et al. 343/702
 2004/0137950 A1 * 7/2004 Bolin et al. 455/562.1
 2007/0021159 A1 * 1/2007 Kaneoya 455/575.3
 2007/0164910 A1 * 7/2007 Qi et al. 343/702
 2007/0182658 A1 8/2007 Ozden
 2007/0241971 A1 * 10/2007 Tsujimura et al. 343/702
 2009/0197654 A1 8/2009 Teshima et al.
 2009/0315785 A1 * 12/2009 Yang 343/702
 2011/0001673 A1 1/2011 You et al.
 2011/0053653 A1 * 3/2011 Tho H04M 1/0249
 455/566
 2012/0039050 A1 * 2/2012 Chang et al. 361/749
 2012/0129582 A1 * 5/2012 Hongo et al. 455/575.3

FOREIGN PATENT DOCUMENTS

CN 1554137 A 12/2004
 CN 1642403 7/2005
 CN 1642403 A 7/2005
 CN 1977425 6/2007
 CN 101944921 1/2011
 CN 101944921 A1 1/2011
 JP 2009-4875 A 1/2009
 JP 2009004875 A * 1/2009
 KR 10-2005-0032287 A 4/2005
 KR 10-2011-0008606 1/2011
 KR 10-2011-0008606 A 1/2011
 WO WO 2011/068674 A2 6/2011

OTHER PUBLICATIONS

English Machine translation of Japanese publication 2009-4875.
 European Search Report for European Application No. 11005565.4,
 dated Nov. 6, 2013.
 English machine translation of Japanese publication 2006-129038.*
 English machine translation of Japanese publication 2009-004875.*
 English machine translation of Korean publication 10-2009-
 0066027 published Jan. 27, 2011.*
 European Patent Office Application Serial No. 11005565.4, Search
 Report dated Nov. 6, 2013, 5 pages.
 The State Intellectual Property Office of the People's Republic of
 China Application Serial No. 201110283371.1, Office Action dated
 May 6, 2014, 7 pages.

* cited by examiner

FIG. 1

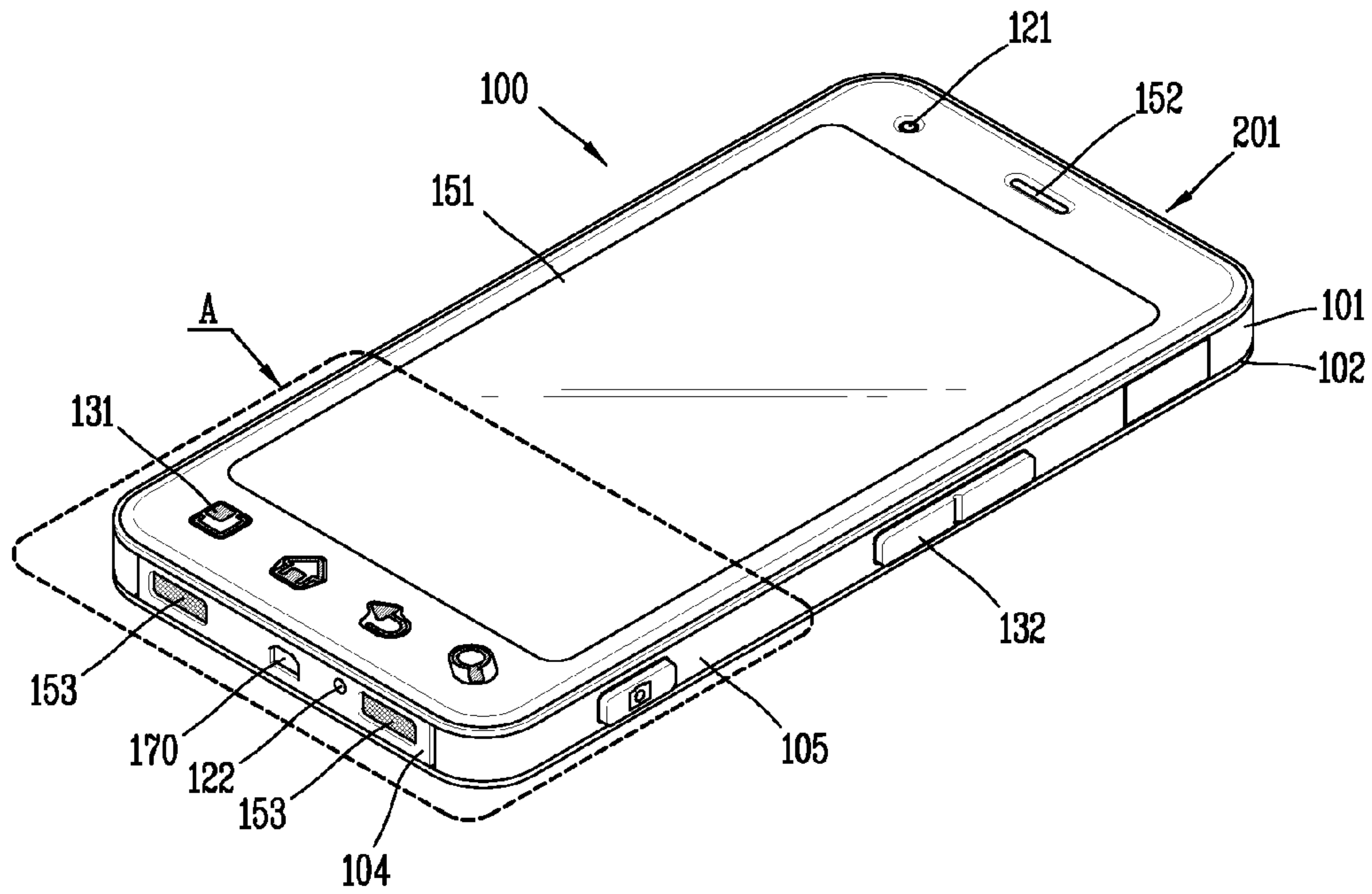

FIG. 2

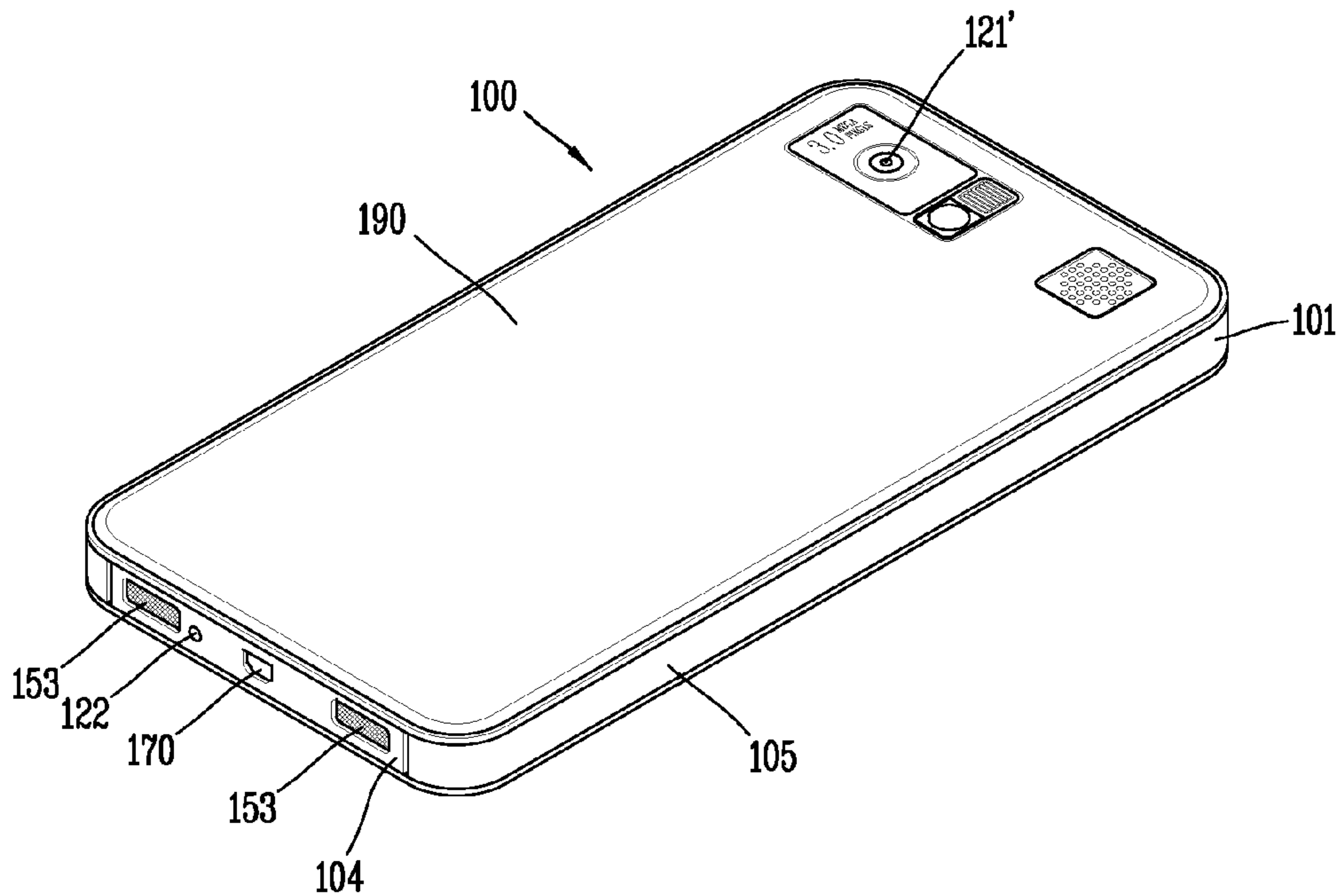

FIG. 3

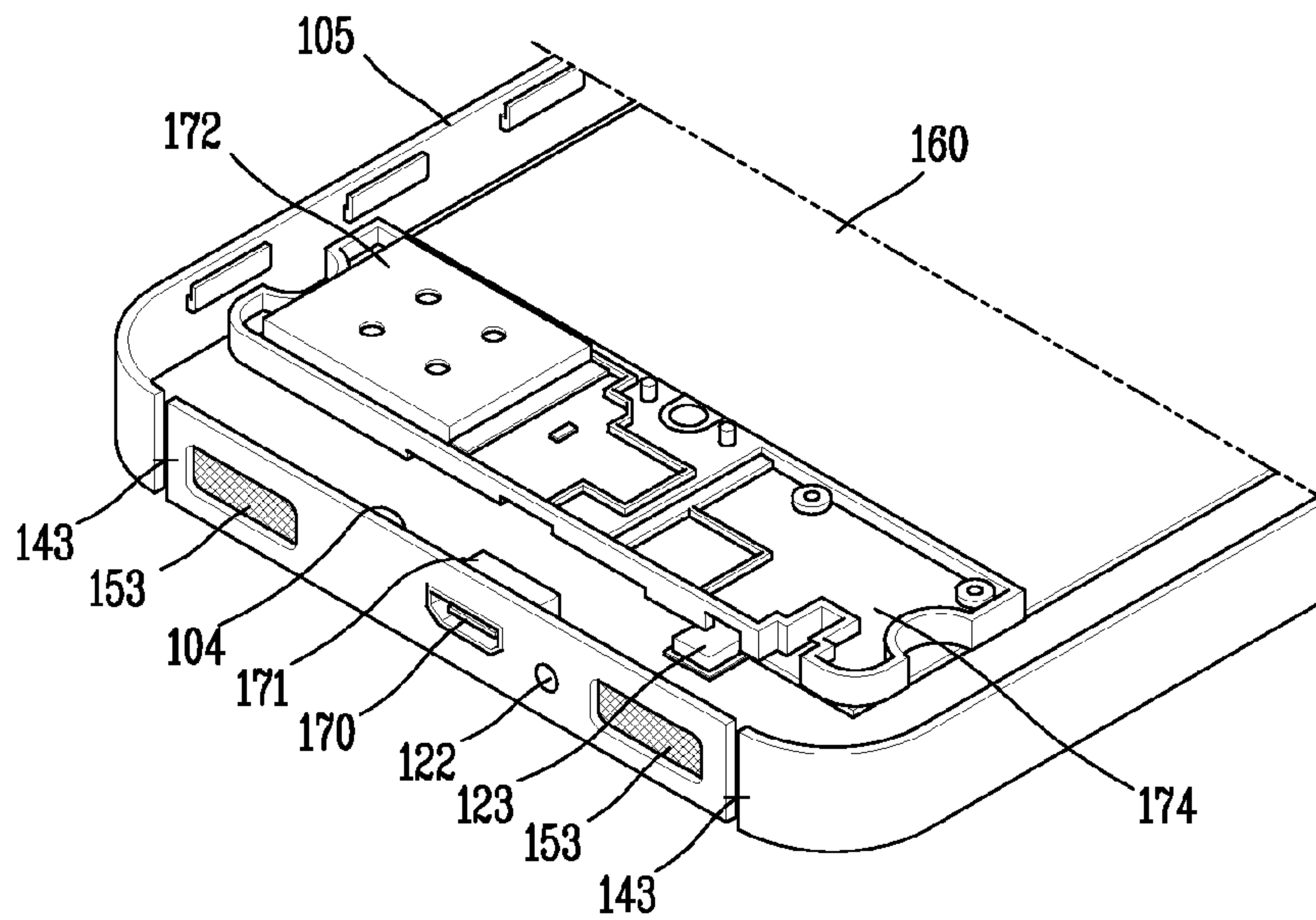

FIG. 4

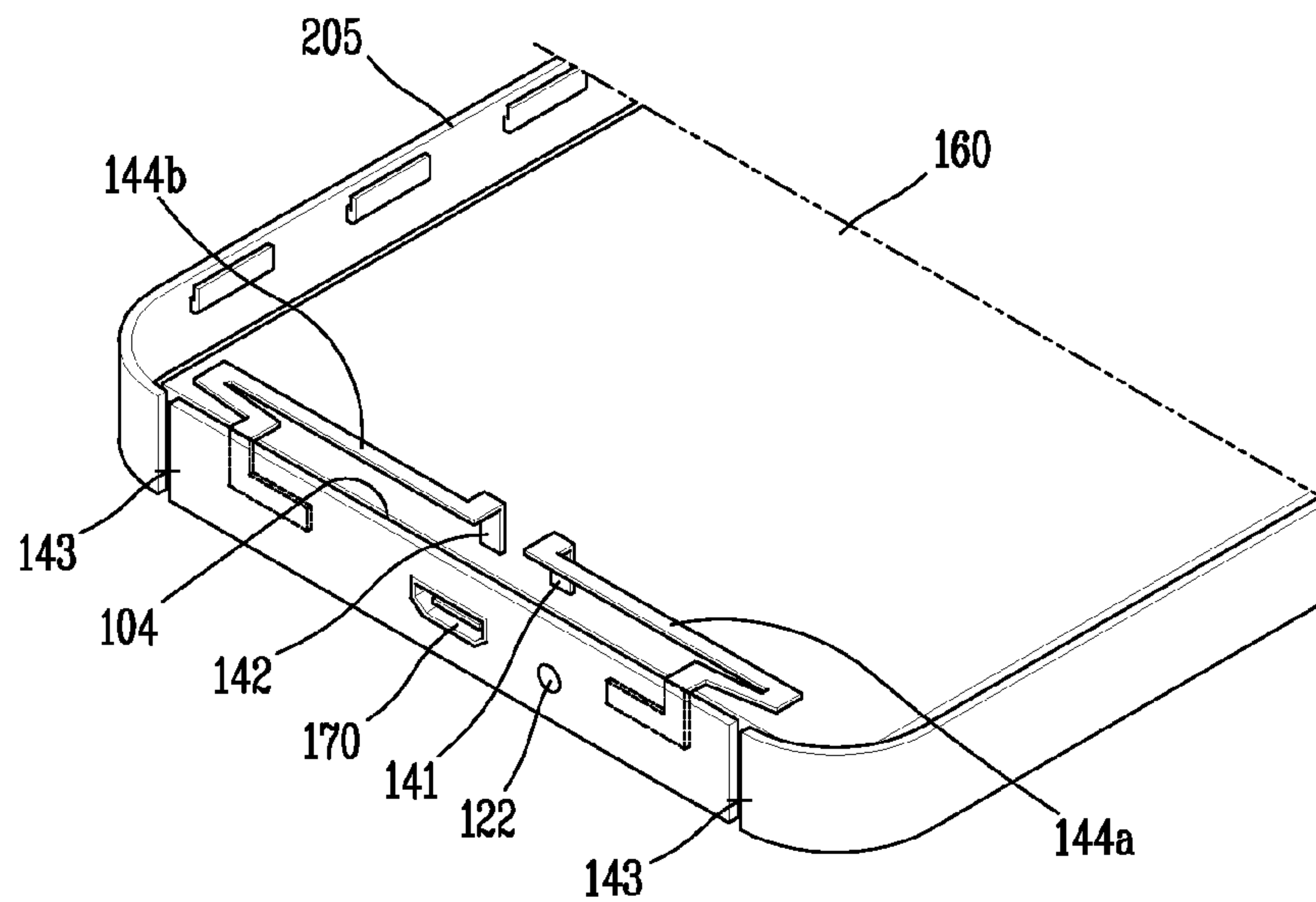

FIG. 5A

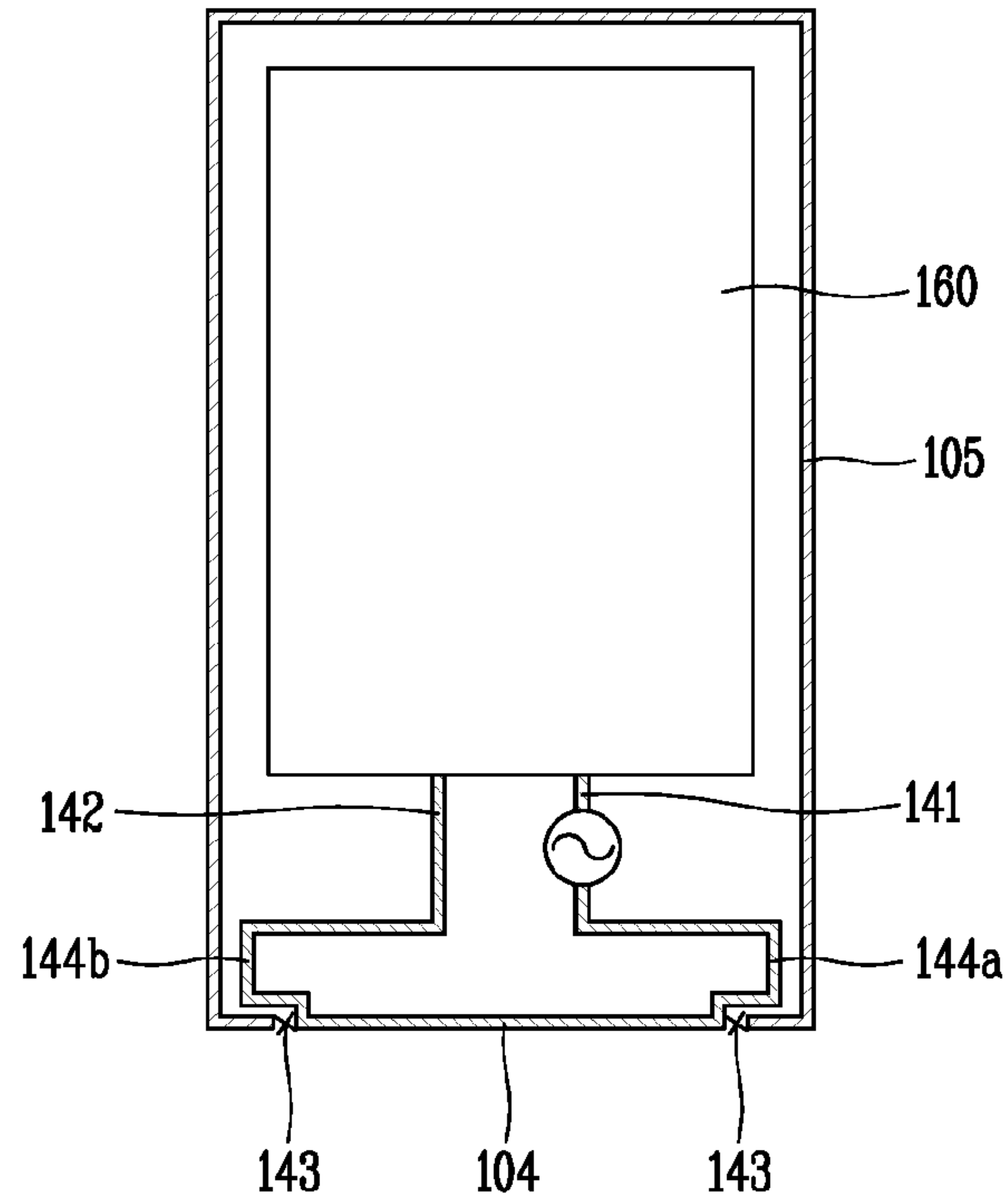

FIG. 5B

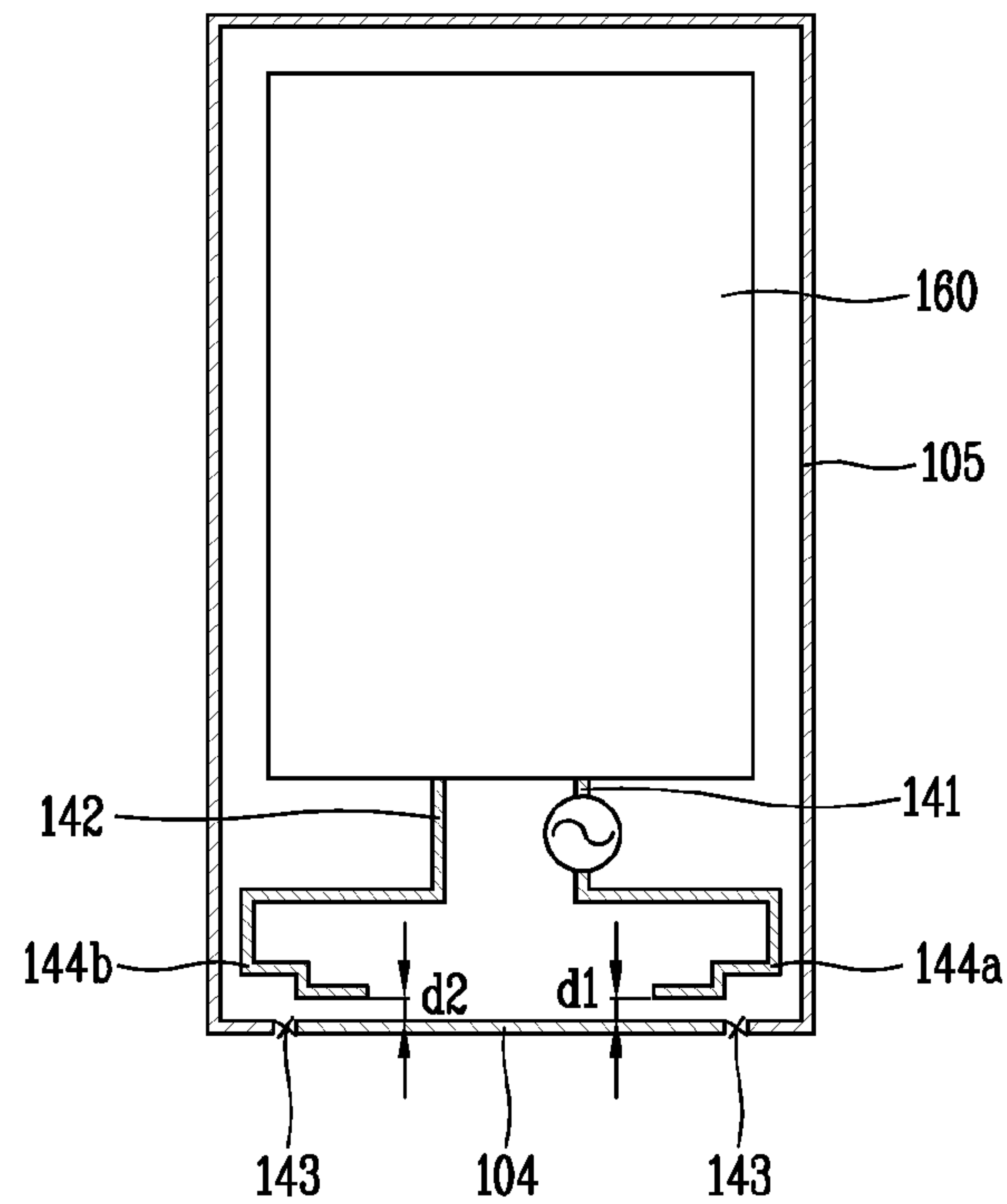

FIG. 5C

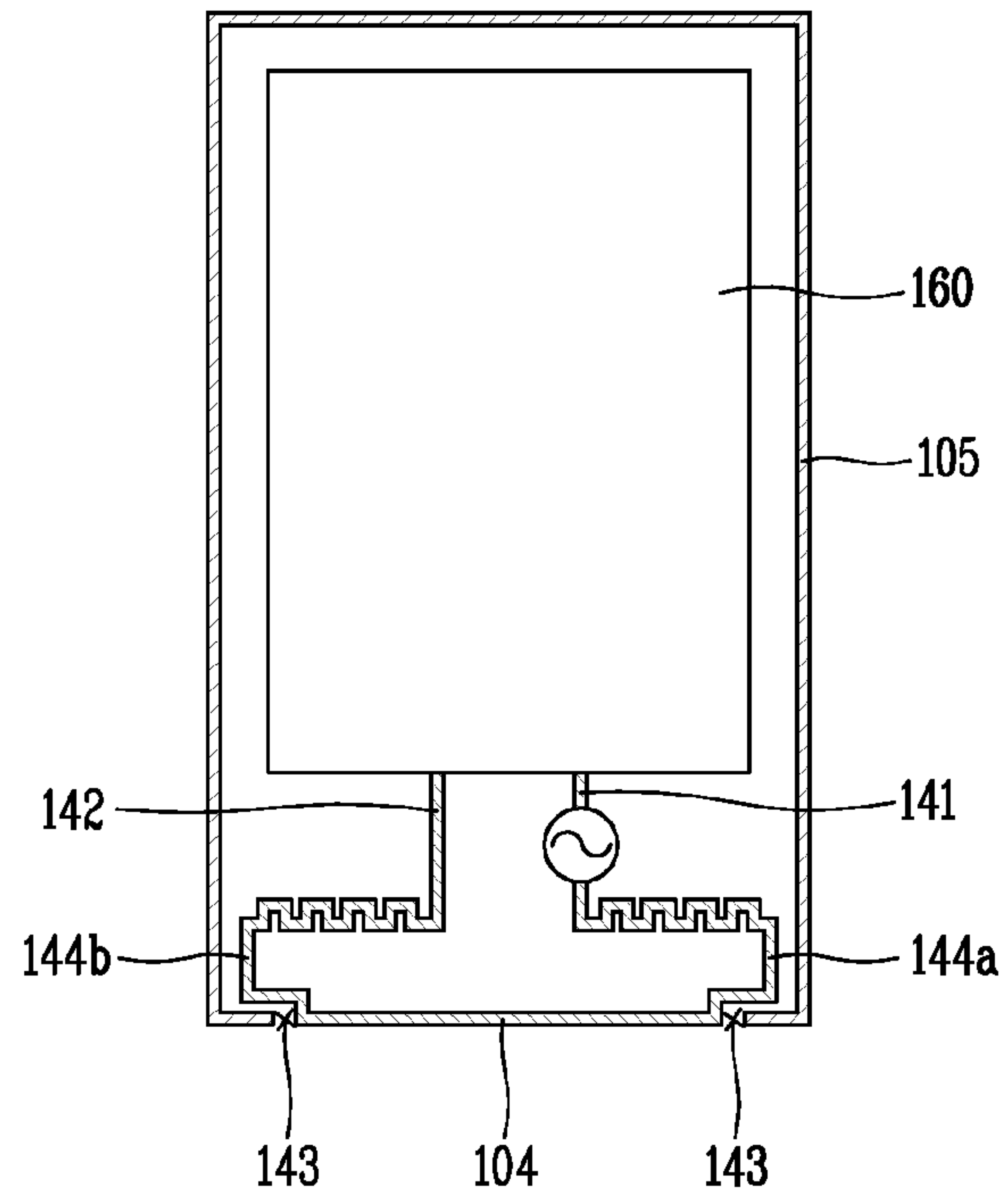

FIG. 5D

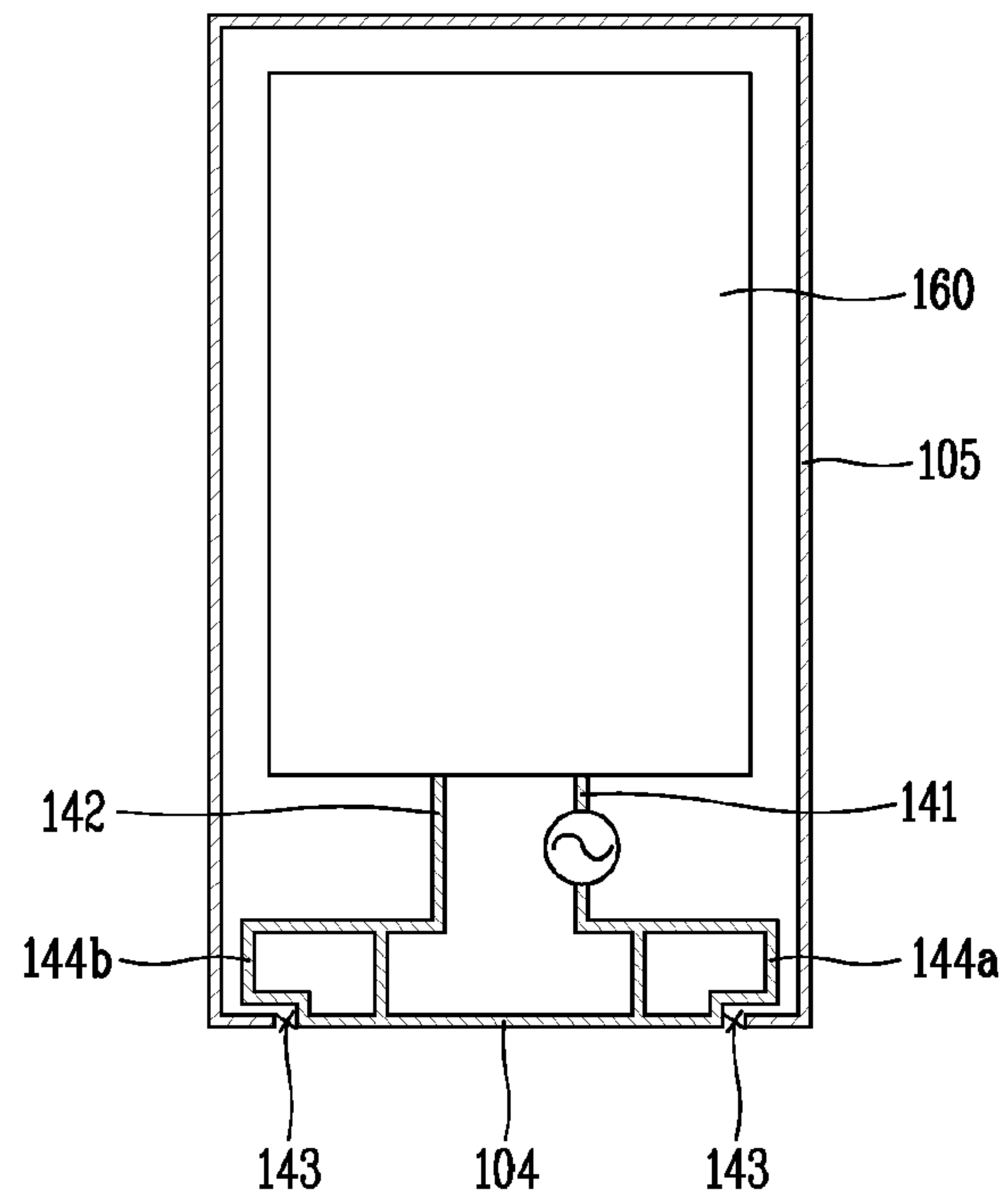

FIG. 5E

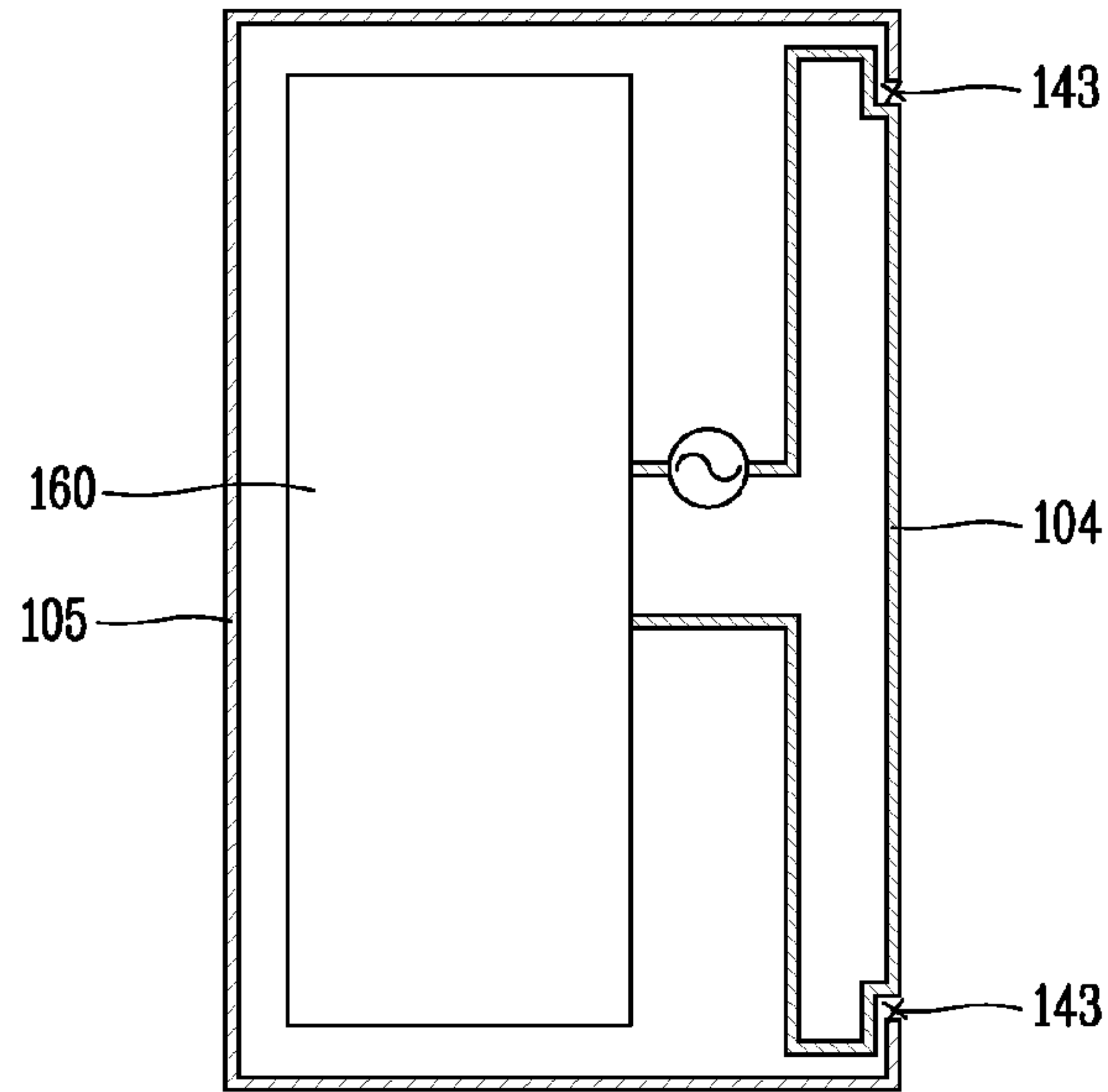

FIG. 5F

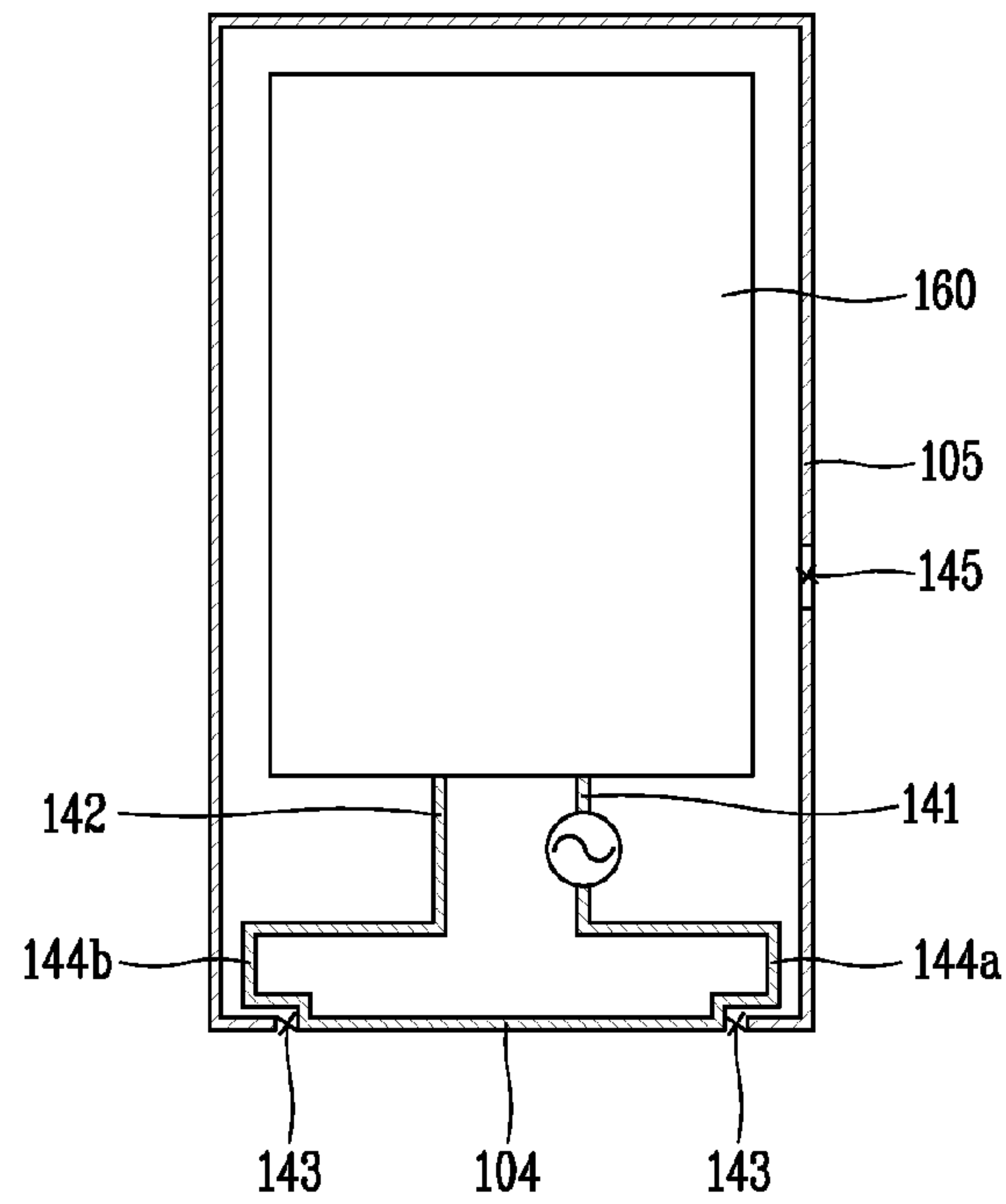

FIG. 5G

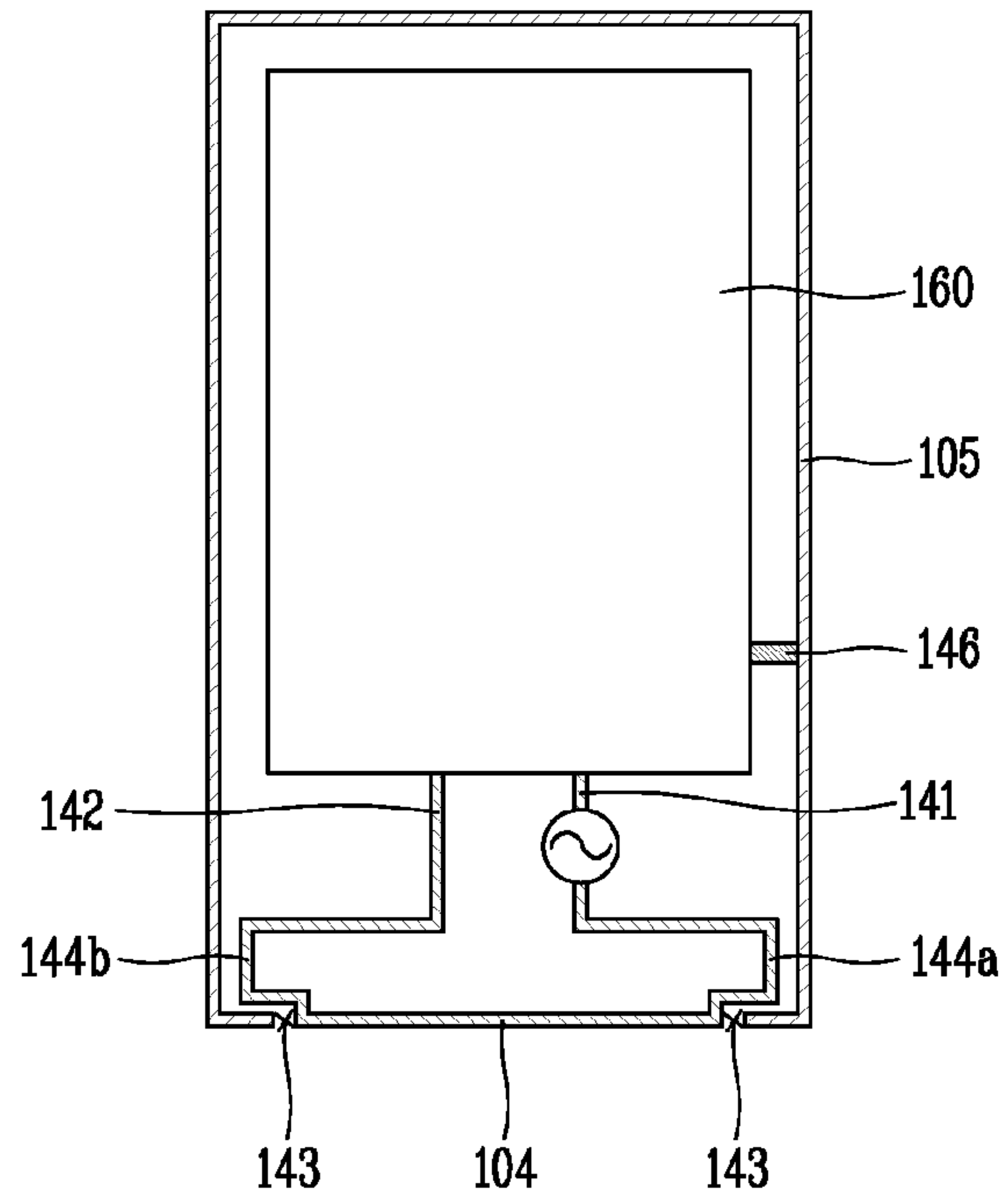

FIG. 5H

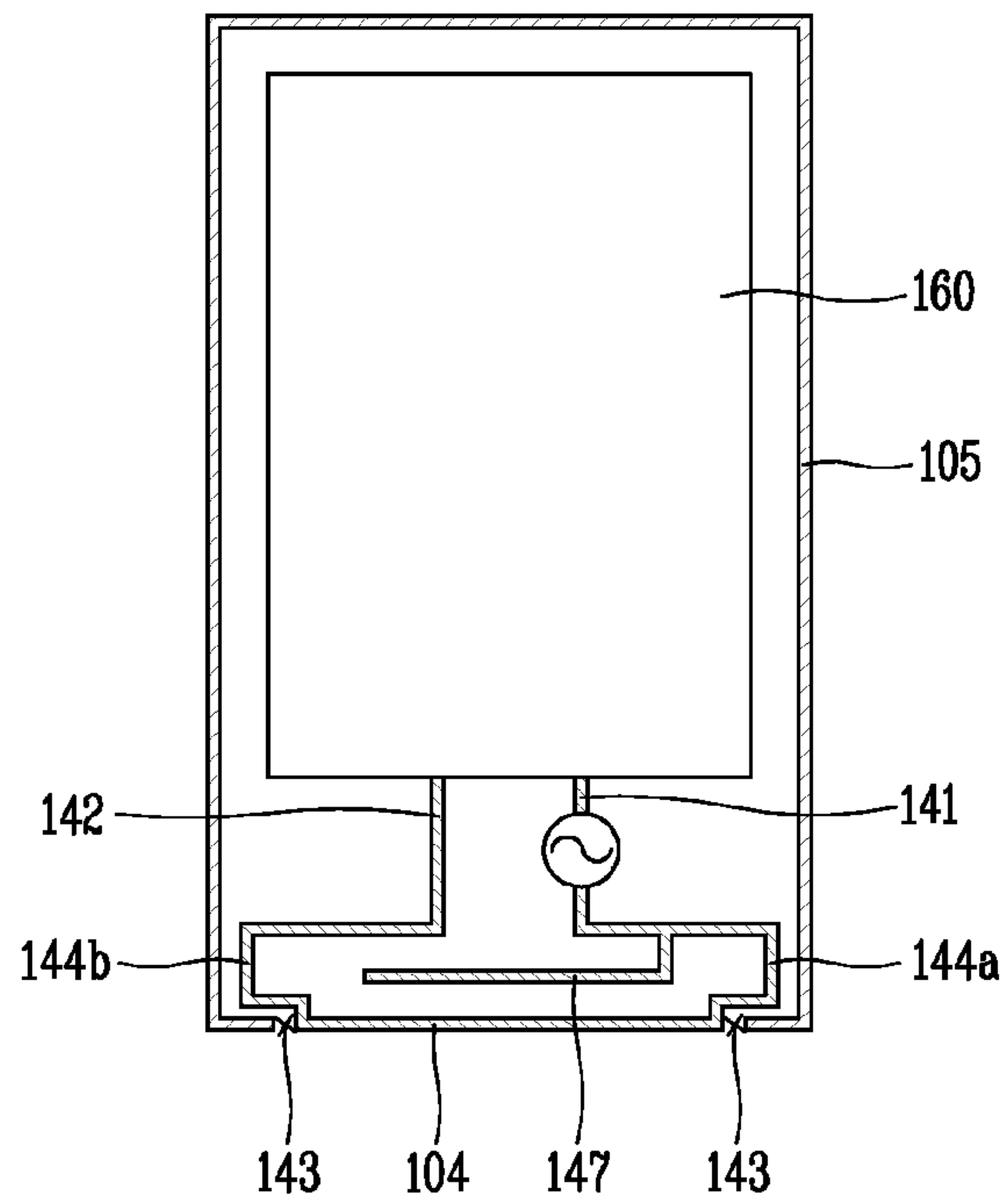

FIG. 6

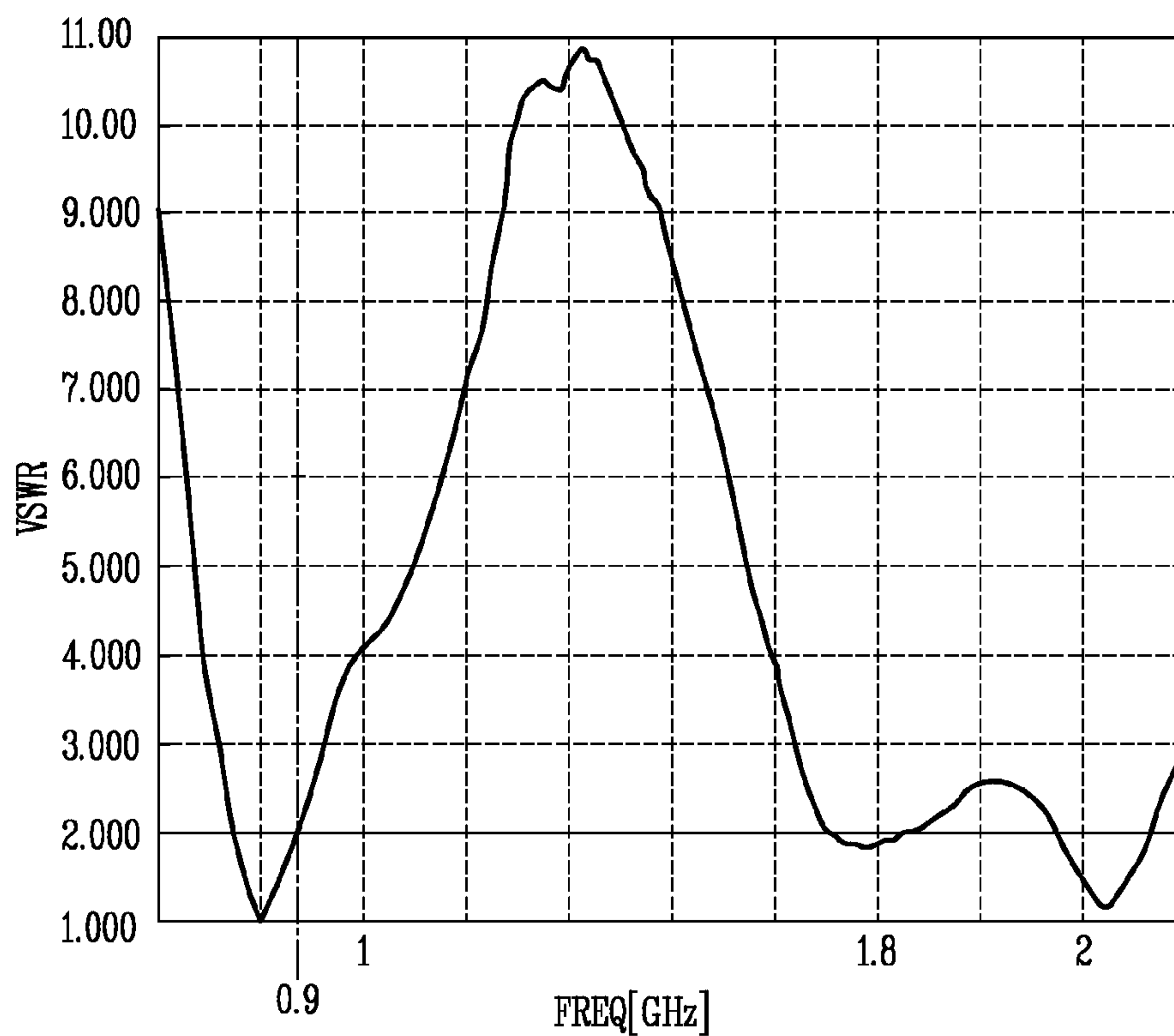

FIG. 7

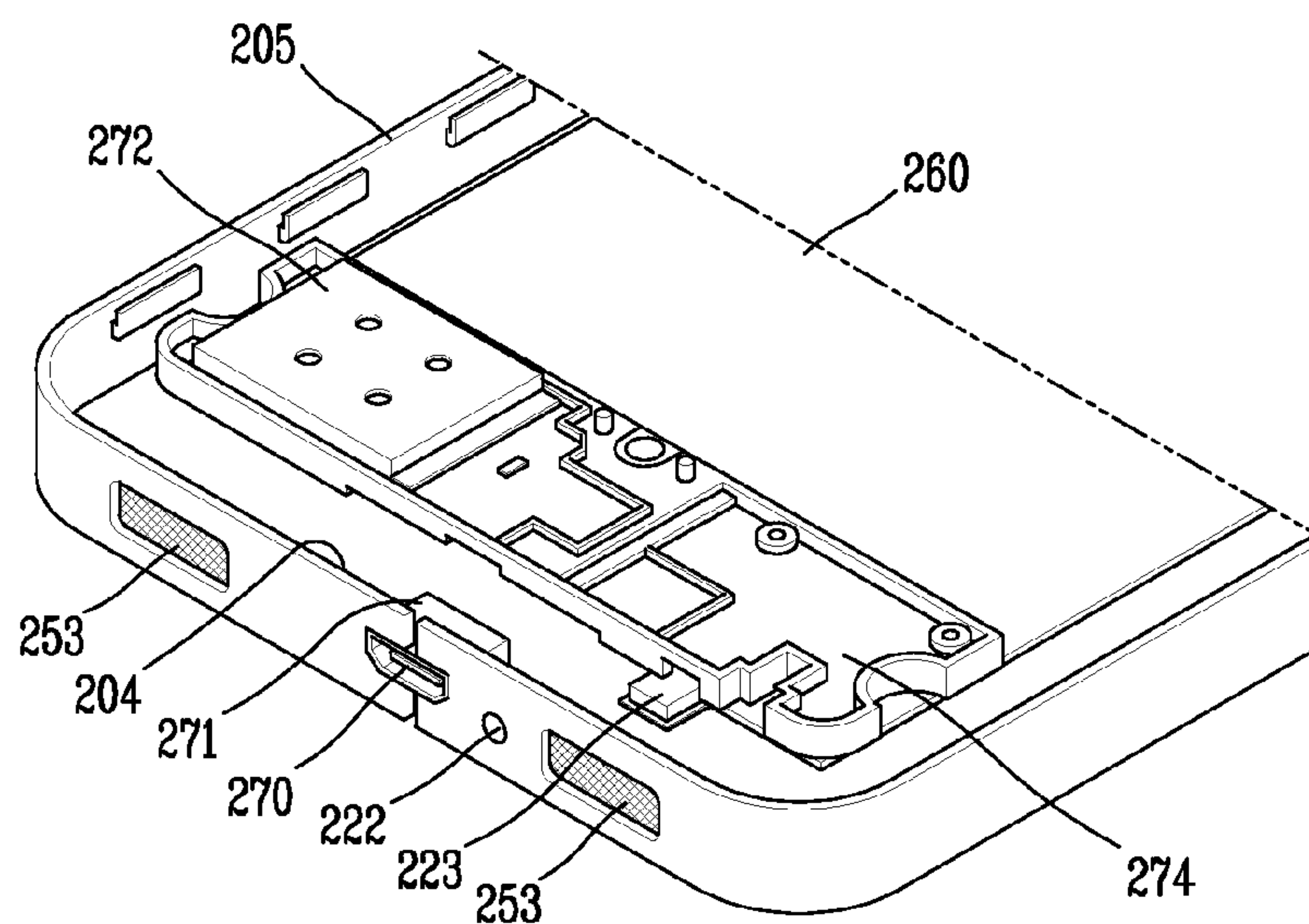

FIG. 8

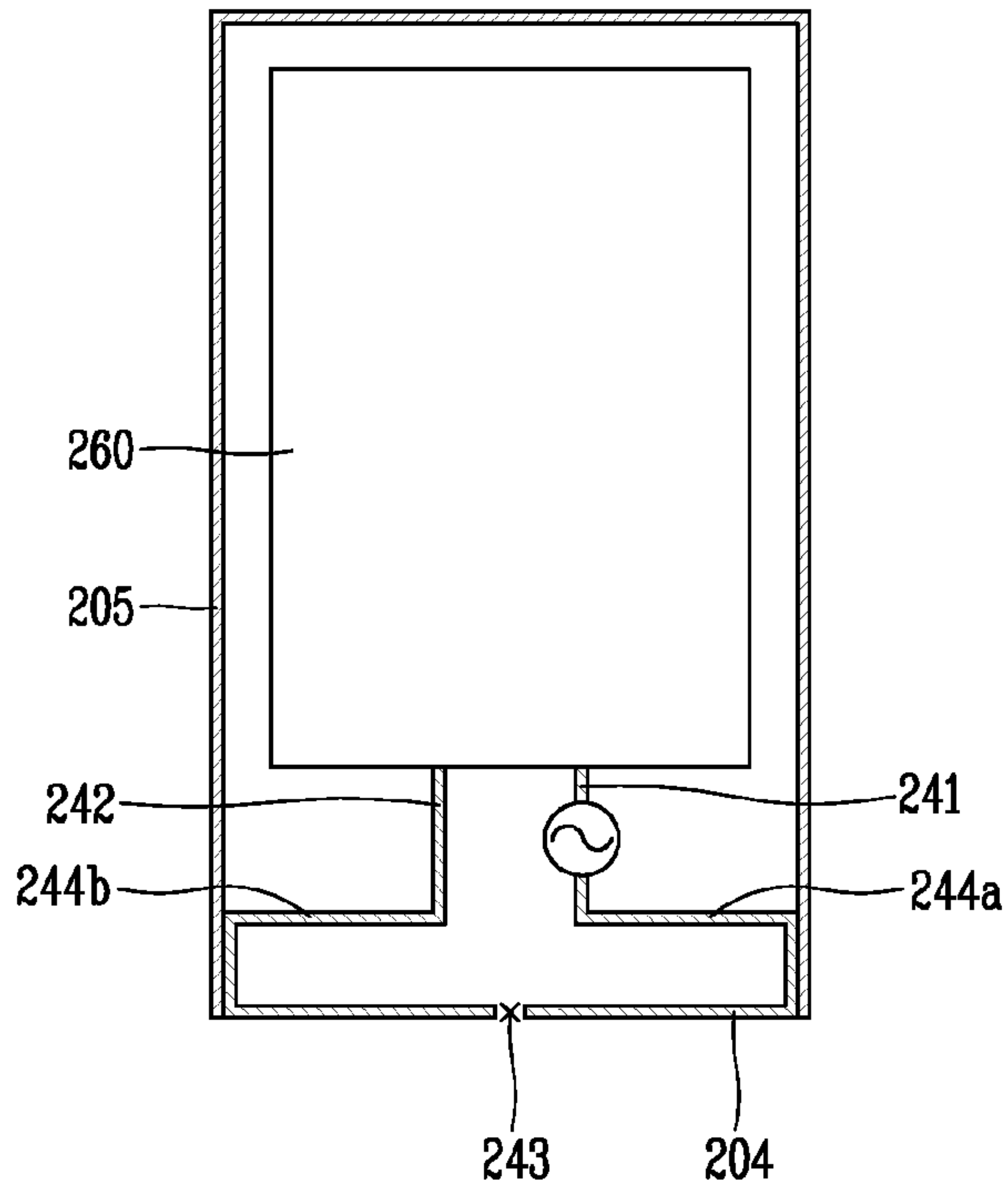
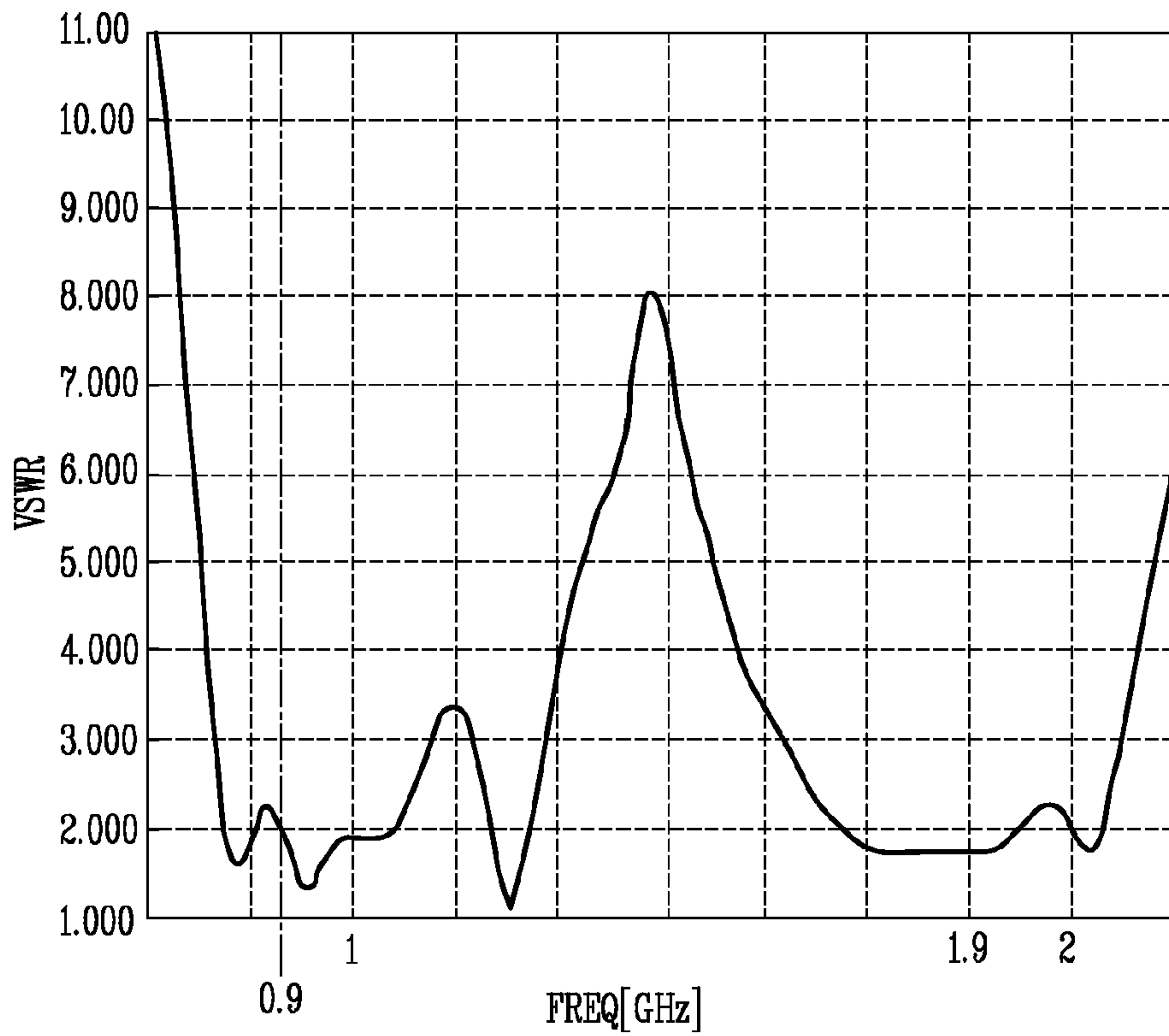

FIG. 9



MOBILE TERMINAL

Matter enclosed in heavy brackets [] appears in the original patent but forms no part of this reissue specification; matter printed in italics indicates the additions made by reissue; a claim printed with strikethrough indicates that the claim was canceled, disclaimed, or held invalid by a prior post-patent action or proceeding.

CROSS-REFERENCE TO RELATED APPLICATIONS

[Pursuant to 35 U.S.C. §119(a), this application claims the benefit of earlier filing date and right of priority to Korean Application No. 10-2011-0017410, filed on Feb. 25, 2011, the contents of which is incorporated by reference herein in its entirety.] *This application is a reissue application of U.S. application Ser. No. 13/161,418, issued as U.S. Pat. No. 9,431,693 on Aug. 30, 2016. The present application also claims the benefit under 35 U.S.C. § 119(a) to Patent Application No. 10-2011-0017410, filed in Republic of Korea on Feb. 25, 2011, all of which are incorporated by reference into the present application.*

BACKGROUND OF THE INVENTION

1. Field of the Invention

The present disclosure relates to a mobile terminal having an antenna transmitting and receiving radio electromagnetic waves.

2. Description of the Related Art

Mobile communication services continue to be evolved by the development of mobile communication technologies along with the consumer's request for more various services. The early stage of mobile communication services was simply focused on voice communications. However, in recent years, various mobile communication services have come out, such as multimedia services such as music or cinema, wireless portable Internet services allowing the Internet to be used while moving, and satellite communication services providing mobile communications beyond national boundaries.

On the other hand, as an antenna of the mobile communication terminal is made smaller in a typical mobile communication terminal, the radiation efficiency of the antenna is reduced, the frequency band is decreased, and the antenna gain is reduced. However, the miniaturization, multifunction, and high performance of a mobile communication terminal are continuously required in spite of the decreased performances. Accordingly, the miniaturization and high performance of an antenna which is used in the mobile communication system is also required.

An antenna for the mobile communication terminal in the related art has a $\frac{1}{4}$ wavelength monopole or helical shape, which is protruded to the outside, thereby causing difficulty in the user's portability as well as having a rigidity problem. In order to solve those problems, the studies for an embedded antenna have been actively carried out.

SUMMARY OF THE INVENTION

The present invention has been contrived to solve the foregoing problems, and an aspect of the present disclosure is to provide a mobile terminal having an antenna device with a more enhanced performance.

In order to accomplish the foregoing task, a mobile terminal associated with an example of the present invention may include a terminal body including a circuit board formed to process radio signals, a first radiator separated from the circuit board and disposed to be overlapped with the circuit board, a second radiator disposed adjacent to the first radiator, a first power feed connecting portion allowing the first radiator and the circuit board to be power feed connected, and a first ground connecting portion allowing the circuit board and the second radiator to be ground connected.

According to an example of the present invention, the first power feed connecting portion and the second ground connecting portion are electrically connected by an inductor.

Furthermore, in order to accomplish the foregoing task, according to the present invention, there is disclosed a mobile terminal including a display area formed to display visual information on a surface of the terminal body, a display panel disposed adjacent to an end portion of the terminal body to allow the display area to be extended to the end portion thereof, and an antenna portion overlapped with the display panel and formed to reduce a separation distance from the display panel, wherein the antenna portion includes a first radiator power feed connected to a circuit board and a second radiator disposed adjacent to the first radiator to be coupled therewith and ground connected to the circuit board.

Furthermore, in order to accomplish the foregoing task, according to the present invention, there is disclosed a mobile terminal including an antenna portion formed to radiate radio signals and a terminal body having an electrical ground, wherein the antenna portion includes a first radiator and a second radiator disposed and coupled adjacent to each other, a first power feed connecting portion formed to power feed the first radiator, and a first ground connecting portion formed to ground connect the second radiator to the electrical ground.

As described above, according to a mobile terminal associated with at least one embodiment of the present invention, two radiators are disposed adjacent to each other, thereby providing an antenna satisfying a multi-band characteristic even in a space having an effect caused by the circuit board or display panel within the terminal body.

Furthermore, due to this, it may be possible to secure economical efficiency through the miniaturization of the terminal and the simplification of the components.

As described above, according to a mobile terminal associated with at least one embodiment of the present invention, electrical elements and an antenna are disposed adjacent to each other, thereby allowing an effective use of the space within the terminal.

Furthermore, the primary radiation section is formed to be directed to the outside in the length direction from the bottom end, thereby reducing the deterioration of a radiation characteristic caused by an hand effect in a high-frequency band.

BRIEF DESCRIPTION OF THE DRAWINGS

The accompanying drawings, which are included to provide a further understanding of the invention and are incorporated in and constitute a part of this specification, illustrate embodiments of the invention and together with the description serve to explain the principles of the invention.

In the drawings:

FIG. 1 is a front perspective view illustrating a front shape of a mobile terminal associated with an embodiment of the present invention;

3

FIG. 2 is a rear perspective view illustrating the mobile terminal of FIG. 1;

FIG. 3 is a perspective view illustrating a configuration in which a display unit is removed from the "A" portion of FIG. 1;

FIG. 4 is a conceptual view schematically illustrating the configuration of FIG. 3;

FIG. 5A through 5H are conceptual views of a loop antenna according to an embodiment of the present invention, illustrating the modified embodiment of each antenna, respectively;

FIG. 6 is a graph illustrating a voltage standing wave ratio based on frequency in case of an antenna according to an embodiment of the present invention;

FIG. 7 is a perspective view illustrating a configuration in which a display unit is removed from the "A" portion of FIG. 1 according to another embodiment of the present invention;

FIG. 8 is a conceptual view illustrating a loop antenna according to another embodiment of the present invention; and

FIG. 9 is a graph illustrating a voltage standing wave ratio based on frequency in case of an antenna according to another embodiment of the present invention.

DETAILED DESCRIPTION OF THE INVENTION

Hereinafter, a mobile terminal associated with the present invention will be described in more detail with reference to the accompanying drawings. The suffixes "module" and "unit or portion" for components used in the following description merely provided only for facilitation of preparing this specification, and thus they are not granted a specific meaning or function. This specification employs like/similar reference numerals for like/similar components irrespective of different embodiments, so they all will be understood by the first description. The expression in the singular form in this specification will cover the expression in the plural form unless otherwise indicated obviously from the context.

A mobile terminal disclosed herein may include a portable phone, a smart phone, a laptop computer, a digital broadcast terminal, a personal digital assistant (PDA), a portable multimedia player (PMP), a navigation, and the like. However, it would be easily understood by those skilled in the art that a configuration according to the following description may be also applicable to a stationary terminal such as a digital TV, a desktop computer, and the like.

FIG. 1 is a front perspective view illustrating an example of the mobile terminal 100 associated with the present invention.

The mobile terminal 100 disclosed herein is provided with a bar-type terminal body. However, the present invention is not only limited to this, but also applicable to various structures such as a slide type, a folder type, a swivel type, a swing type, and the like, in which two and more bodies are combined with each other in a relatively movable manner.

The body includes a case (casing, housing, cover, etc.) forming an appearance of the terminal. In this embodiment, the case may be divided into a first case 101 and a second case 102. At least one middle case may be additionally disposed between the first case 101 and the second case 102.

The cases may be formed by injection-molding a synthetic resin or may be also formed of a metal material such as stainless steel (STS), titanium (Ti), or the like.

A display unit 151, an audio output module 152, a camera 121, a user input unit 131, 132, a microphone 122, an

4

interface 170, and the like may be arranged on the terminal body, mainly on the first case 101.

The display unit 151 occupies a most portion of the main surface of the first case 101. The audio output unit 152 and the camera 121 are disposed on a region adjacent to one of both ends of the display unit 151, and the user input unit 131 and the microphone 122 are disposed on a region adjacent to the other end thereof. The user interface 132 and the interface 170, and the like, may be disposed on a lateral surface of the first case 101 and the second case 102.

The display unit 151 may display(output) information processed in the mobile terminal 100. For example, when the mobile terminal 100 is in a phone call mode, the display unit 151 may display a User Interface (UI) or a Graphic User Interface (GUI) associated with a call. When the mobile terminal 100 is in a video call mode or image capturing mode, the display unit 151 may display a captured image and/or received image, a UI or GUI.

The display unit 151 may include at least one of a Liquid Crystal Display (LCD), a Thin Film Transistor-LCD (TFT-LCD), an Organic Light Emitting Diode (OLED) display, a flexible display, a three-dimensional (3D) display.

Some of those displays may be configured with a transmission type or light transmission type to allow viewing of the exterior through the display unit, which may be called transparent displays. An example of the typical transparent displays may include a Transparent OLED (TOLED), and the like. Under this configuration, a user can view an object positioned at a rear side of a terminal body through a region occupied by the display unit 151 of the terminal body.

The display unit 151 may be implemented in two or more in number according to a configured aspect of the portable terminal 100. For instance, a plurality of the display units 151 may be arranged on one surface to be spaced apart from or integrated with each other, or may be arranged on different surfaces.

Here, if the display unit 151 and a touch sensitive sensor (referred to as a touch sensor) have an interlayer structure, the structure may be referred to as a touch screen. The display unit 151 may be used as an input device rather than an output device. The touch sensor may be implemented as a touch film, a touch sheet, a touch pad, and the like.

The interface 170 may serve as an interface with all external devices connected with the mobile terminal. For example, the external devices may include a wired/wireless headset, an external power charger, a wired/wireless data port, a card socket (e.g., memory card, SIM/UIM card, etc.), and the like. The interface 170 may be used to receive data or power from an external device and deliver it to each element within the mobile terminal, or may be used to transmit data within the mobile terminal to the external device.

The touch sensor may be configured to convert changes of a pressure applied to a specific part of the display unit 151, or a capacitance occurring from a specific part of the display unit 151, into electric input signals. Also, the touch sensor may be configured to sense not only a touched position and a touched area, but also a touch pressure.

When touch inputs are sensed by the touch sensors, corresponding signals are transmitted to a touch controller. The touch controller processes the received signals, and then transmits corresponding data to the controller. Accordingly, the controller may sense which region of the display unit 151 has been touched.

The user input unit is configured to receive a command for controlling the operation of the mobile communication terminal 100, and may include plurality of manipulation

units **131**, **132**. The manipulation units **131**, **132** may be commonly designated as a manipulating portion, and any method may be employed if it is a tactile manner allowing the user to perform manipulation with a tactile feeling.

The content inputted by the first and the second manipulation unit **131**, **132** may be configured in various ways. For example, the first manipulation unit **131** may receive a command, such as start, end, scroll, or the like, and the second manipulation unit **132** may receive a command such as volume control of sound outputted from the audio output unit **152**, switching into a touch recognition mode of the display unit **151**, or the like.

FIG. **2** is a rear perspective view illustrating the mobile terminal of FIG. **1**.

Referring to FIG. **2**, a camera **121'** may additionally be mounted on a rear surface, i.e. a second case **102** of the terminal body. The camera **121'** has a capturing direction substantially opposite to that of the camera **121**, and may have a different number of pixels from that of the camera **121**.

For example, it is preferable that the camera **121** has a lower number of pixels to allow the user to capture the user's face and send it to another party in case of a video call or the like, and the camera **121'** has a higher number of pixels to allow the user to capture a typical object but not to immediately send it. The cameras **121** and **121'** may be provided in the terminal body in a rotatable or pop-up manner.

A flash and a mirror may be additionally disposed adjacent to the camera **121'**. The flash emits light toward an object when capturing the object with the camera **121'**. The mirror allows the user to reflect the user's own face when the user wants to capture himself or herself in a self-portrait mode using the camera **121'**.

An audio output unit may be additionally disposed at a rear surface of the terminal body. The audio output unit may implement a stereo function together with the audio output unit **152**, and may be used to implement a speakerphone mode during voice communication.

An antenna (not shown) for receiving a broadcasting signal in addition to an antenna for communication or the like may be additionally disposed at a lateral surface of the terminal body. An antenna constituting part of the broadcasting reception module may be provided in a retractable manner on the terminal body.

The power supply unit for supplying power to the mobile terminal **100** may be mounted on the terminal body. The power supply unit may be provided such that it is incorporated in the terminal body, or directly drawn out of the terminal body in a detachable manner. The power supply unit may be embedded by a battery cover **190**.

A touch pad (not shown) for detecting a touch may be additionally mounted on the second case **102**. The touch pad may be configured with a light transmission type similar to the display unit **151**. In this case, if the display unit **151** is configured to output visual information from both surfaces thereof, then the visual information may be also recognized through the touch pad. All the information outputted to both surfaces thereof may be also controlled by the touch pad. On the contrary, a display unit may be additionally mounted on the touch pad, and thus a touch screen may be also disposed on the second case **102**.

The touch pad may be operated in relation to the display unit **151** of the first case **101**. The touch pad may be disposed in parallel to a rear side of the display unit **151**. The touch pad may have the same or smaller size than the display unit **151**.

FIG. **3** is a perspective view illustrating a configuration in which a display unit is removed from the "A" portion of FIG. **1**, and FIG. **4** is a conceptual view schematically illustrating the configuration of FIG. **3**.

As illustrated in the drawing, a mobile terminal according to the present disclosure is a mobile terminal having a loop antenna, and the loop antenna uses a portion of the case formed along a lateral surface of the terminal body as part of a conductive loop. In other words, a loop antenna according to an embodiment of the present disclosure forms a closed loop together with a first member **104**, a power feed connecting portion **141**, a ground connecting portion **142**, and a circuit board **160**. The first member **104** and the second member **105** are part of a cover forming an external appearance of the terminal, and disposed to cover a lateral surface of the circuit board **160**. The first member **104** may be formed by including a metal material, and operated as a main radiator in the loop antenna. Furthermore, at least part of the second member **105** is made of a conductive metal material to form another conductive loop.

The first member **104** and the power feed connecting portion **141** are connected to a first pattern **144a**, and the first member **104** and the ground connecting portion **142** are connected to a second pattern **144b**. The patterns are formed on a carrier **174**. The first member **104**, the second member **105** and the patterns are combined with one another to form a conductive loop operated at any one of a code division multiple access (CDMA) and global system for mobile (GSM) communication band (800-1000 MHz), a personal communication system (PCS) and digital cellular system (DCS) band (1700-1900 MHz), and a wideband CDMA (W-CDMA) communication band (2.4 GHz), securing sufficient band characteristics, respectively. The conductive loop may be formed to satisfy a half wavelength of a specific frequency.

The first pattern **144a** and the second pattern **144b** may have a conductor in a meander type, and the conductor may be fabricated in various forms according to the resonance or frequency characteristics. A current is power fed to the conductor through the power feed connecting portion **141**, and a current power fed through the ground connecting portion **142** is short circuited.

A slit portion **143** is formed between the first member **104** and the second member **105** to separate them from each other. Due to this, the first member **104** may form a conductive loop together with the power feed connecting portion **141**, the ground connecting portion **142**, and the patterns. In other words, even if the second member **105** includes a conductive metal material, a current flow to the second member **105** may be blocked or a coupling effect thereon may be reduced to be operated as a loop antenna.

The power feed connecting portion **141** allows the first member **104** to be power fed by electrical connection (or electro-magnetic (EM) power feeding method), and the ground connecting portion **142** is ground connected to the first member **104** to be electrically shorted, thereby implementing antenna resonance frequency and impedance matching.

The power feed connecting portion **141** allows the first member **104** to be electrically connected to the power feeding device (not shown). For the connection thereof, the power feed connecting portion **141** may include a power feeding plate, a power feeding clip, and a power feeding line. Here, the power feeding plate, power feeding clip, and power feeding line are electrically connected to one another

to transfer a current (or voltage) power fed through the power feeding device to a conductor of the radiating portion. Here, the power feeding line may include a microstrip printed on the substrate.

The ground connecting portion **142** allows an end of the first member **104** or second member **105** to be electrically connected to the electrical ground, thereby allowing the first member **104** or second member **105** to be grounded. The electrical earth may be a ground on the circuit board **160**. Here, the ground connecting portion **142** may have at least two paths having a different length, and formed to have a switch corresponding to each path. Furthermore, each path allows the electrical earth and radiators (for example, a first member) to be connected with a different length in a selective manner. Here, the path may be an electrical pathway for connecting the earth to the radiator and may be formed by including a grounding plate, a grounding clip, and a grounding line. Furthermore, the grounding line may be formed with a different length, thereby providing a different length of the path.

As illustrated in FIG. 3, a speaker module **172**, an interface module **171**, or a microphone module **123** may be mounted at a location surrounded by the first member **104** and second member **105**, and disposed adjacent to the first member **104**. Furthermore, the speaker module **172**, interface module **171**, or microphone module **123** may be mounted on a carrier **174**, and the carrier **174** may be disposed at the foregoing location.

At least one or holes communicated with the inner and outer portion of the body may be formed on the first member **104**. A speaker **153** hole, an interface **170** housing, or a microphone **122** housing may be disposed on the hole.

In general, electrical elements are not mounted in a space obstructing the radiation efficiency of an antenna. However, when a portion of the case formed along a lateral surface of the terminal body as illustrated herein is used as part of a conductive loop, the electrical element and antenna may be disposed adjacent to each other to reduce efficiency deterioration, thereby allowing the effective use of a space within the terminal.

Modification of the Embodiment 1

FIG. 5A through 5H are conceptual views of a loop antenna according to an embodiment of the present invention, illustrating the modified embodiment of each antenna, respectively. The modification may be implemented by the embodiment 1 as well as the embodiment 2 which will be described later.

According to the embodiment illustrated in FIG. 5A, a loop is formed from the power feed connecting portion **141** connected to the circuit board **160** to the ground connecting portion **142** through the patterns **144a**, **144b** and first member **104**. The slit portions **143** are formed between the first member **104** and second member **105**. In the loop antenna formed at a bottom end of the terminal, the primary radiation section may be formed to be directed to the outside in the length direction from the bottom end of the terminal, thereby reducing the deterioration of a radiation characteristic caused by an hand effect in a high-frequency band.

According to the embodiment illustrated in FIG. 5B, the patterns **144a**, **144b** and the first member **104** are separated from each other by a predetermined distance (d_1 , d_2) to achieve coupling power feeding and coupling grounding. In the modified embodiment, a contact structure is not required to connect the first member **104** to the patterns, and thus the process may be simplified to reduce the unit cost. For

example, only the first pattern **144a** and the first member **104** are power fed by coupling, and the second pattern **144b** and the first member **104** are directly brought into contact with each other to form a ground connection, and thus an electrical characteristic at an end of the loop structure will be fixed, thereby satisfying the broadband characteristic of an antenna.

According to the embodiment illustrated in FIG. 5C, the patterns are formed in a meander structure to form a conductive pattern within a limited space, thereby further miniaturizing the antenna.

According to the embodiment illustrated in FIG. 5D, it may have a structure in which the patterns and the first member **104** are connected to each other, thereby providing a plurality of loops. As a result, it may be possible to transmit and receive radio signals corresponding to a plurality of frequencies required by the terminal as well as a specific frequency.

According to the embodiment illustrated in FIG. 5E, the first member **104** may be formed on the left or right side of the terminal as well as the top or bottom end thereof.

According to the embodiment illustrated in FIGS. 5F and 5G, at least one or more slits **145** are formed to communicate the inner and outer portion of the body to the second member **105**, or the second member **105** and the circuit board **160** are electrically connected **146** to each other at least one or more points. Through this type of tuning, it may be possible to obtain a desired bandwidth and a desired resonance frequency.

According to the embodiment illustrated in FIG. 5H, it may further include a sub radiator **147** extended from any one point of the patterns or extended from any one point of the first member **104** to expand the bandwidth at a specific frequency. In this case, the first member **104** may be operated as a main radiator for a specific frequency.

FIG. 6 is a graph illustrating a voltage standing wave ratio based on frequency in an antenna according to the embodiment of FIG. 5A. As illustrated in the drawing, the voltage standing wave ratio in a code division multiple access (CDMA) and global system for mobile (GSM) communication band (800-1000 MHz), a personal communication system (PCS) and digital cellular system (DCS) band (1700-1900 MHz), and a wideband CDMA (W-CDMA) communication band (2.4 GHz) is less than 3, respectively, and thus it is seen that the broadband characteristics at a radio frequency are excellent.

Embodiment 2

FIG. 7 is a perspective view illustrating a configuration in which a display unit is removed from the "A" portion of FIG. 1 according to another embodiment of the present invention, and FIG. 8 is a conceptual view illustrating a loop antenna according to another embodiment of the present invention.

As described above, according to the present embodiment, the same or similar reference numerals will be used to designate the same or similar elements, and the description thereof will be replaced with the foregoing description.

As illustrated in the drawing, a mobile terminal according to still another embodiment of the present invention is a mobile terminal having a loop antenna, and the loop antenna uses a portion of the case formed along a lateral surface of the terminal body as part of a conductive loop. In other words, a loop antenna according to an embodiment of the present disclosure forms a conductive loop together with a

conductive member **204**, a power feed connecting portion **241**, a ground connecting portion **242**, and a circuit board **260**.

The conductive member **204** and the bezel member **205** are part of a cover forming an external appearance of the terminal, and disposed to cover a lateral surface of the circuit board **260**. The conductive member **204** may be formed by including a conductive metal material, and operated as a main radiator in the loop antenna. Furthermore, at least part of the bezel member **205** may be made of a conductive metal material to form another conductive loop.

The conductive member **204** and the power feed connecting portion **241** are connected to a third pattern **244a**, and the conductive member **204** and the ground connecting portion **242** are connected to a fourth pattern **244b**. The patterns are formed on a carrier **274**. The conductive member **204**, the bezel member **205** and the patterns are combined with one another to form a conductive loop operated at any one of a code division multiple access (CDMA) and global system for mobile (GSM) communication band (800-1000 MHz), a personal communication system (PCS) and digital cellular system (DCS) band (1700-1900 MHz), and a wideband CDMA (W-CDMA) communication band (2.4 GHz), securing sufficient band characteristics, respectively. The conductive loop may be formed to satisfy a half wavelength of a specific frequency.

The third pattern **244a** and the fourth pattern **244b** may have a conductor in a meander type, and the conductor may be fabricated in various forms according to the resonance or frequency characteristics. A current is power fed to the conductor through the power feed connecting portion **241**, and a current power fed through the ground connecting portion **242** is short circuited.

A through portion passed through at least part of the conductive member **204** to communicate the inner and outer portion of the body or a separate slit portion **243** configured to separate the conductive member **204** into a plurality of members are formed on the conductive member **204**. Due to this, the conductive member **204** is combined together with the power feed connecting portion **241**, the ground connecting portion **242**, the bezel member **205**, and the patterns to form at least one or more conductive loops capable of transmitting and receiving radio signals at a specific frequency.

As illustrated in FIG. 7, a speaker module **272**, an interface module **271**, or a microphone module **223** may be mounted at a location surrounded by the conductive member **204** and bezel member **205** and disposed adjacent to the conductive member **204**. Furthermore, the speaker module **272**, interface module **271**, or microphone module **223** may be mounted on a carrier **274**, and the carrier **274** may be disposed at the foregoing location.

At least one or holes communicated with the inner and outer portion of the body may be formed on the conductive member **204**. A speaker **253** hole, an interface **270** housing, or a microphone **222** housing may be disposed on the hole.

FIG. 9 is a graph illustrating a voltage standing wave ratio based on frequency in an antenna according to the embodiment of FIG. 8. As illustrated in the drawing, the voltage standing wave ratio in a code division multiple access (CDMA) and global system for mobile (GSM) communication band (800-1000 MHz), a personal communication system (PCS) and digital cellular system (DCS) band (1700-1900 MHz), and a wideband CDMA (W-CDMA) communication band (2.4 GHz) is less than 3, respectively, and thus it is seen that the broadband characteristics at a radio frequency are excellent.

The configurations and methods according to the above-described embodiments will not be applicable in a limited way to the foregoing mobile communication terminal, and all or part of each embodiment may be selectively combined and configured to make various modifications thereto.

What is claimed is:

[1. A mobile terminal comprising:
a circuit board;

at least one antenna pattern disposed inside of a case that forms an exterior of the mobile terminal such that no portion of the at least one antenna pattern is exposed externally, wherein the at least one antenna pattern is operable as a radiator;

a metal cover constructed as part of the case, the metal cover divided into a first member and a second member separated from the first member such that the first member does not contact the second member, wherein the first member is electrically connected to a part of the at least one antenna pattern without a contact structure between the first member and the part of the at least one antenna pattern, and wherein the first member and the second member are separated from each other by a first slit portion formed at a first end portion of the first member and a second slit portion formed at a second end portion of the first member;

a power feed connector for facilitating an electric power feed connection between the first member and the circuit board; and

a ground connector for facilitating an electric ground connection between the first member and the circuit board,

wherein the at least one antenna pattern is separated from the first member by a gap having a predetermined distance for coupling with the first member, and wherein the first slit portion and the second slit portion are configured to block a current flow from the first member to the second member.]

[2. The mobile terminal of claim 1, further comprising a speaker module, an interface module or a microphone module located in an area defined by the circuit board, the first member, and the second member.]

[3. The mobile terminal of claim 1, wherein the at least one antenna pattern comprises:

a first pattern extending from the power feed connector and forming a conductive loop, the first pattern separated from the first member by a gap having a predetermined distance for facilitating a coupling for power feeding.]

[4. The mobile terminal of claim 3, wherein the at least one antenna pattern further comprises:

a second pattern extending from the ground connector and forming a conductive loop, the second pattern separated from the first member by a gap having a predetermined distance for facilitating a coupling for grounding.]

[5. The mobile terminal of claim 1, wherein the power feed connector and the ground connector are disposed adjacent to each other.]

[6. The mobile terminal of claim 1, wherein the first member is operable as a main radiator and further comprises a sub-radiator for enhancing a radiation pattern of the main radiator, the sub-radiator having a predetermined length and extending from a portion of the first member.]

[7. The mobile terminal of claim 1, wherein the second member and the circuit board are electrically connected to each other at one or more points.]

11

- [8.** The mobile terminal of claim 1, wherein:
the power feed connector, the first member and the ground connector form a conductive loop; and
the conductive loop has one or more paths that connect the power feed connector to the ground connector via the first member and that have a length of a half wavelength corresponding to a specific frequency.]
- [9.** A mobile terminal comprising:
a circuit board;
at least one antenna pattern disposed inside of a case that forms an exterior of the mobile terminal such that no portion of the at least one antenna pattern is exposed externally, wherein the at least one antenna pattern is operable as a radiator;
a metal cover constructed as part of the case forming an exterior of the mobile terminal, the metal cover divided into a conductive member and a bezel member separated from the conductive member such that the conductive member does not contact the bezel member, wherein the conductive member is electrically connected to a part of the at least one antenna pattern without a contact structure between the conductive member and the part of the at least one antenna pattern;
a power feed connector coupled with the conductive member;
a ground connector coupled with the conductive member and an embedded ground such that the ground connector, the conductive member and the power feed connector form a conductive loop, and
either a through portion that is located at an end of the mobile terminal and passes through at least a portion of the conductive member in order to adjoin an interior and the exterior of the mobile terminal or a slit portion separating the conductive member into a plurality of members,
wherein the at least one antenna pattern is separated from the conductive member by a gap having a predetermined distance for coupling with the conductive member, and
wherein the through portion or the slot portion is configured to block a current flow from the conductive member to the bezel member.]
- [10.** The mobile terminal of claim 9, wherein the conductive loop has one or more paths connecting the power feed connector to the ground connector via the conductive member.]
- [11.** The mobile terminal of claim 10, wherein the one or more paths have a length of a half wavelength corresponding to a specific frequency.]
- [12.** The mobile terminal of claim 9, further comprising a speaker module, an interface module or a microphone module located adjacent to the conductive member.]
- [13.** The mobile terminal of claim 9, wherein the at least one antenna pattern comprises:
a first pattern extending from the power feed connector and further forming the conductive loop, the first pattern separated from the conductive member by a gap having a predetermined distance for facilitating a coupling for power feeding.]
- [14.** The mobile terminal of claim 13, wherein the at least one antenna pattern further comprises:
a second pattern extending from the ground connector and further forming the conductive loop, the second pattern separated from the conductive member by a gap having a predetermined distance for facilitating a coupling for grounding.]

12

- [15.** The mobile terminal of claim 14, wherein the power feed connector and the ground connector are disposed adjacent to each other.]
- [16.** The mobile terminal of claim 9, wherein the conductive member is operated as a main radiator and further comprises a sub-radiator for enhancing a radiation pattern of the main radiator, the sub-radiator having a predetermined length and extending from a portion of the conductive member.]
- [17.** The mobile terminal of claim 9, wherein the bezel member is disposed to cover a lateral surface of the mobile terminal not covered by the conductive member.]
- [18.** The mobile terminal of claim 17, wherein the bezel member has one or more slits adjoining the interior and the exterior of the mobile terminal.]
- [19.** The mobile terminal of claim 17, wherein the bezel member and the circuit board are electrically connected to each other at one or more points.]
- [20.** The mobile terminal of claim 2, wherein the first member has at least one hole adjoining an interior and the exterior of the mobile terminal.]
- [21.** The mobile terminal of claim 20, further comprising:
a speaker hole, an interface housing or a microphone housing disposed at the at least one hole.]
- [22.** The mobile terminal of claim 1, wherein the first member is formed at a bottom end of the case.]
- [23.** The mobile terminal of claim 12, wherein the conductive member has at least one hole adjoining the interior and the exterior of the mobile terminal.]
- [24.** The mobile terminal of claim 23, further comprising:
a speaker hole, an interface housing, or a microphone housing disposed at the at least one hole.]
- [25.** The mobile terminal of claim 9, wherein the conductive member is formed at a bottom end of the case.]
- 26.** *A mobile terminal comprising:
a circuit board;
an antenna configured to transceive radio signals; and
a case having two long lateral surfaces and two short lateral surfaces which form an appearance of the mobile terminal, the case comprising a metal material, wherein the case comprises:
a first conductive member being a first part of a bottom lateral surface of the two short lateral surfaces of the case;
a second conductive member being a second part of the bottom lateral surface and part of at least one of the two long lateral surfaces connected to the second part, wherein the second conductive member is separated from the first conductive member such that the first conductive member does not contact the second conductive member;
a first slit portion located at a first end of the first conductive member; and
a second slit portion located at a second end of the first conductive member, the second end being opposite to the first end of the first conductive member,
wherein the first slit portion and the second slit portion are located at the bottom lateral surface of the case, wherein the antenna comprises:
the first conductive member forming a radiator of the antenna;
a power feed connecting portion electrically connecting the first conductive member with the circuit board; and
a ground connecting portion electrically ground-connecting the first conductive member with the circuit board, such that the power feed connecting portion, the first*

13

conductive member and the ground connecting portion form a conductive loop for transceiving the radio signals,
 wherein the power feed connecting portion and the ground connecting portion of the antenna are not exposed externally,
 wherein the first conductive member includes an inner surface and an outer surface in which the inner surface is not exposed externally and the outer surface is exposed externally,
 wherein the second conductive member includes an inner surface and an outer surface in which the inner surface is not exposed externally and the outer surface is exposed externally,
 wherein the outer surface of the first conductive member is substantially flush with the outer surface of the second conductive member,
 wherein the first conductive member, the first slit portion and the second slit portion are located at the bottom lateral surface of the case so the antenna radiates the radio signals to an outside of the mobile terminal in the length direction of the mobile terminal,
 wherein the first slit portion is located between the first end of the first conductive member and a first end of the second conductive member at the bottom lateral surface,
 wherein the second slit portion is located between the second end of the first conductive member and a second end of the second conductive member at the bottom lateral surface, and
 wherein each of the first slit portion and the second slit portion is not filled with the metal material of the case.

27. The mobile terminal according to claim 26, wherein each of the first slit portion and the second slit portion has two long sides and two short sides,
 wherein the two short sides of the first slit portion and the second slit portion are open areas having no metal material of the case, and
 wherein one of the two long sides of the first slit portion and the second slit portion adjoins the first conductive member of the case and the other one of the two long sides of the first slit portion and the second slit portion adjoins the second conductive member of the case.

28. The mobile terminal according to claim 27, wherein the first slit portion and the second slit portion are opened to the outside of the mobile terminal in a perpendicular direction to the two short sides and the two long sides of the first slit portion and the second slit portion.

29. The mobile terminal according to claim 28, wherein the two long sides of the first slit portion and the second slit portion are located in a y-axis thickness direction of the mobile terminal, and
 wherein the two short sides of the first slit portion and the second slit portion are located in an x-axis width direction of the mobile terminal.

30. The mobile terminal according to claim 26, wherein the first conductive member has at least one hole for a speaker, an interface or a microphone.

31. The mobile terminal according to claim 30, wherein the hole is disposed between the first slit portion and the second slit portion and includes the interface for a power supply.

32. The mobile terminal according to claim 26, wherein the second conductive member extends from each of the two long lateral surfaces to the one of the two short lateral

14

surfaces such that the second conductive member is adjacent to the first end and the second end of the first conductive member, and
 wherein the first conductive member and the second conductive member are separated by the first slit portion and the second slit portion.

33. The mobile terminal according to claim 26, wherein at least a part of the second conductive member is configured to operate as a radiator.

34. The mobile terminal according to claim 26, wherein the second conductive member and the circuit board are electrically connected to each other.

35. The mobile terminal according to claim 26, wherein a primary radiation section of the antenna is directed to the outside of the mobile terminal in the length direction from the one of the two short lateral surfaces of the case to reduce a deterioration of a radiation characteristic caused by a hand holding the mobile terminal.

36. The mobile terminal according to claim 26, further comprising:
 a speaker module, an interface module or a microphone module disposed adjacent to the first conductive member.

37. The mobile terminal according to claim 26, further comprising:
 a display unit,
 wherein the case comprises a first case and a second case, wherein the first case is disposed at a front side of the case, and the second case is disposed at a rear side of the case, and
 wherein a screen of the display unit occupies most of the front side of the first case.

38. A method of operating a mobile terminal, wherein the mobile terminal comprises a circuit board, an antenna and a case, the method comprising:
 transceiving radio signals through the antenna,
 wherein the case has two long lateral surfaces and two short lateral surfaces which form an appearance of the mobile terminal, the case comprising a metal material, wherein the case comprises:
 a first conductive member being a first part of a bottom lateral surface of the two short lateral surfaces of the case;
 a second conductive member being a second part of the bottom lateral surface and part of at least one of the two long lateral surfaces connected to the second part, wherein the second conductive member is separated from the first conductive member such that the first conductive member does not contact the second conductive member;
 a first slit portion located at a first end of the first conductive member; and
 a second slit portion located at a second end of the first conductive member, the second end being opposite to the first end of the first conductive member,
 wherein the first slit portion and the second slit portion are located at the bottom lateral surface of the case, wherein the antenna comprises:
 the first conductive member forming a radiator of the antenna;
 a power feed connecting portion electrically connecting the first conductive member with the circuit board; and
 a ground connecting portion electrically ground-connecting the first conductive member with the circuit board, such that the power feed connecting portion, the first

15

conductive member and the ground connecting portion
 form a conductive loop for transceiving the radio
 signals,
 wherein the power feed connecting portion and the
 ground connecting portion of the antenna are not
 exposed externally,
 wherein the first conductive member includes an inner
 surface and an outer surface in which the inner surface
 is not exposed externally and the outer surface is
 exposed externally,
 wherein the second conductive member includes an inner
 surface and an outer surface in which the inner surface
 is not exposed externally and the outer surface is
 exposed externally,
 wherein the outer surface of the first conductive member
 is substantially flush with the outer surface of the
 second conductive member,
 wherein the first conductive member, the first slit portion
 and the second slit portion are located at the bottom
 lateral surface of the case so the antenna radiates the
 radio signals to an outside of the mobile terminal in the
 length direction of the mobile terminal,
 wherein the first slit portion is located between the first
 end of the first conductive member and a first end of the
 second conductive member at the bottom lateral sur-
 face,
 wherein the second slit portion is located between the
 second end of the first conductive member and a second
 end of the second conductive member at the bottom
 lateral surface, and
 wherein each of the first slit portion and the second slit
 portion is not filled with the metal material of the case;
 and
 processing the transceived radio signals.
 39. A mobile terminal comprising:
 a circuit board;
 an antenna configured to transceive radio signals; and
 a case having two long lateral surfaces and two short
 lateral surfaces which form an appearance of the
 mobile terminal,
 the case comprising a metal material,
 wherein the case comprises:
 a first conductive member being a first part of a bottom
 lateral surface of the two short lateral surfaces of the
 case;
 a second conductive member being a second part of the
 bottom lateral surface and part of at least one of the
 two long lateral surfaces connected to the second part;
 a first slit portion located at a first end of the first
 conductive member; and
 a second slit portion located at a second end of the first
 conductive member,
 the second end being opposite to the first end of the first
 conductive member,
 wherein the first slit portion and the second slit portion
 are located at the bottom lateral surface of the case,
 wherein the second conductive member is separated from
 the first conductive member by the first slit and the
 second slit at the bottom lateral surface,
 wherein the antenna comprises:
 the first conductive member forming a radiator of the
 antenna;
 a power feed connecting portion electrically connecting
 the first conductive member with the circuit board; and
 a ground connecting portion electrically ground-connect-
 ing the first conductive member with the circuit board,

16

such that the power feed connecting portion, the first
 conductive member and the ground connecting portion
 form a conductive loop for transceiving the radio
 signals,
 wherein the first conductive member includes an inner
 surface and an outer surface in which the inner surface
 is not exposed externally and the outer surface is
 exposed externally,
 wherein the second conductive member includes an inner
 surface and an outer surface in which the inner surface
 is not exposed externally and the outer surface is
 exposed externally,
 wherein the outer surface of the first conductive member
 is substantially flush with the outer surface of the
 second conductive member,
 wherein the power feed connecting portion and the
 ground connecting portion of the antenna are con-
 nected at the inner surface of the first conductive
 member,
 wherein the first slit portion is located between the first
 end of the first conductive member and a first end of the
 second conductive member at the bottom lateral sur-
 face,
 wherein the second slit portion is located between the
 second end of the first conductive member and a second
 end of the second conductive member at the bottom
 lateral surface, and
 wherein each of the first slit portion and the second slit
 portion is not filled with the metal material of the case.
 40. The mobile terminal according to claim 39, wherein
 each of the first slit portion and the second slit portion has
 two long sides and two short sides,
 wherein the two short sides of the first slit portion and the
 second slit portion are open areas having no metal
 material of the case, and
 wherein one of the two long sides of the first slit portion
 and the second slit portion adjoins the first conductive
 member of the case and the other one of the two long
 sides of the first slit portion and the second slit portion
 adjoins the second conductive member of the case.
 41. The mobile terminal according to claim 40, wherein
 the first slit portion and the second slit portion are opened
 to the outside of the mobile terminal in a perpendicular
 direction to the two short sides and the two long sides of the
 first slit portion and the second slit portion.
 42. The mobile terminal according to claim 41, wherein
 the two long sides of the first slit portion and the second slit
 portion are located in a y-axis thickness direction of the
 mobile terminal, and
 wherein the two short sides of the first slit portion and the
 second slit portion are located in an x-axis width
 direction of the mobile terminal.
 43. The mobile terminal according to claim 39, wherein
 the first conductive member has at least one hole for a
 speaker, an interface or a microphone.
 44. The mobile terminal according to claim 43, wherein
 the hole is disposed between the first slit portion and the
 second slit portion and includes the interface for a power
 supply.
 45. The mobile terminal according to claim 39, wherein
 the second conductive member extends from each of the two
 long lateral surfaces to the one of the two short lateral
 surfaces such that the second conductive member is adjacent
 to the first end and the second end of the first conductive
 member, and

wherein the first conductive member and the second conductive member are separated by the first slit portion and the second slit portion.

46. The mobile terminal according to claim 39, wherein at least a part of the second conductive member is configured to operate as a radiator. 5

47. The mobile terminal according to claim 39, wherein the second conductive member and the circuit board are electrically connected to each other.

48. The mobile terminal according to claim 39, wherein a primary radiation section of the antenna is directed to the outside of the mobile terminal in the length direction from the one of the two short lateral surfaces of the case to reduce a deterioration of a radiation characteristic caused by a hand holding the mobile terminal. 10 15

49. The mobile terminal according to claim 39, further comprising:

a speaker module, an interface module or a microphone module disposed adjacent to the first conductive member. 20

50. The mobile terminal according to claim 39, further comprising:

a display unit,

wherein the case comprises a first case and a second case, wherein the first case is disposed at a front side of the case, and the second case is disposed at a rear side of the case, and 25

wherein a screen of the display unit occupies most of the front side of the first case.

* * * * *

30