



US00RE48722E

(19) **United States**
(12) **Reissued Patent**
Gosling et al.

(10) **Patent Number: US RE48,722 E**
(45) **Date of Reissued Patent: *Sep. 7, 2021**

(54) **INTEGRATED RECONFIGURABLE WALL SYSTEM**

(71) Applicant: **DIRTT ENVIRONMENTAL SOLUTIONS LTD.**, Calgary (CA)

(72) Inventors: **Geoff Gosling**, Calgary (CA); **Mogens F. Smed**, DeWinton (CA)

(73) Assignee: **DIRTT ENVIRONMENTAL SOLUTIONS LTD.**, Calgary (CA)

(*) Notice: This patent is subject to a terminal disclaimer.

(21) Appl. No.: **14/032,931**

(22) Filed: **Sep. 20, 2013**

Related U.S. Patent Documents

Reissue of:

(64) Patent No.: **8,024,901**
Issued: **Sep. 27, 2011**
Appl. No.: **11/205,314**
Filed: **Aug. 17, 2005**

U.S. Applications:

(60) Provisional application No. 60/601,985, filed on Aug. 17, 2004.

(51) **Int. Cl.**
E04H 1/00 (2006.01)
E04B 1/00 (2006.01)
E04B 2/74 (2006.01)

(52) **U.S. Cl.**
CPC **E04B 2/7424** (2013.01); **E04B 2002/742** (2013.01); **E04B 2002/749** (2013.01);
(Continued)

(58) **Field of Classification Search**
CPC **E04B 2/7424**; **E04B 2/742**; **E04B 2/7416**;
E04B 2/7425

(Continued)

(56) **References Cited**

U.S. PATENT DOCUMENTS

2,042,290 A 5/1936 Barrett
2,658,810 A 11/1953 Ellis

(Continued)

FOREIGN PATENT DOCUMENTS

CA 248428 A 3/1925
CA 55086 10/1985

(Continued)

OTHER PUBLICATIONS

International Search Report and Written Opinion for PCT/US2012/042314 dated Jun. 13, 2012.

(Continued)

Primary Examiner — Jeffrey L Gellner

(74) *Attorney, Agent, or Firm* — Workman Nydegger

(57) **ABSTRACT**

A movable reconfigurable wall system having at least one module having a front and rear surface, the at least one module having: vertical end frames disposed at least at its side edges, each the vertical end frame having a vertically extending flange directed toward the front surface and a vertically extending flange directed toward the rear surface; a plurality of horizontal stringers affixed between the pair of vertical end frames; and an aesthetic surface affixed to the stringers; and a removable connecting strip, the connecting strip adapted to affix about one of the two flanges on one of the vertical end frames and join the one of the two flanges to a corresponding flange on one of a second module, a wall bracket, a finishing trim or a connection post.

54 Claims, 23 Drawing Sheets

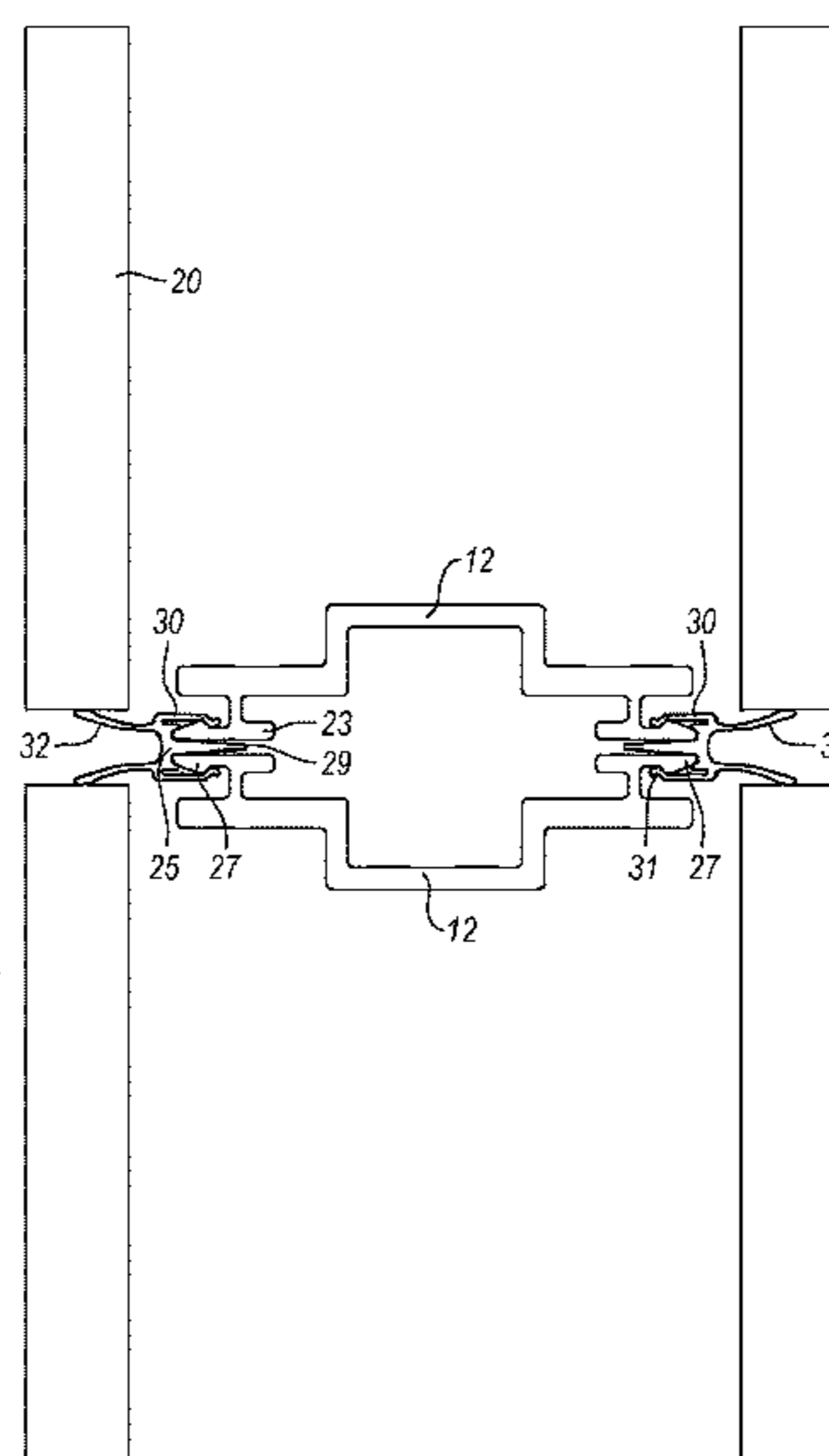
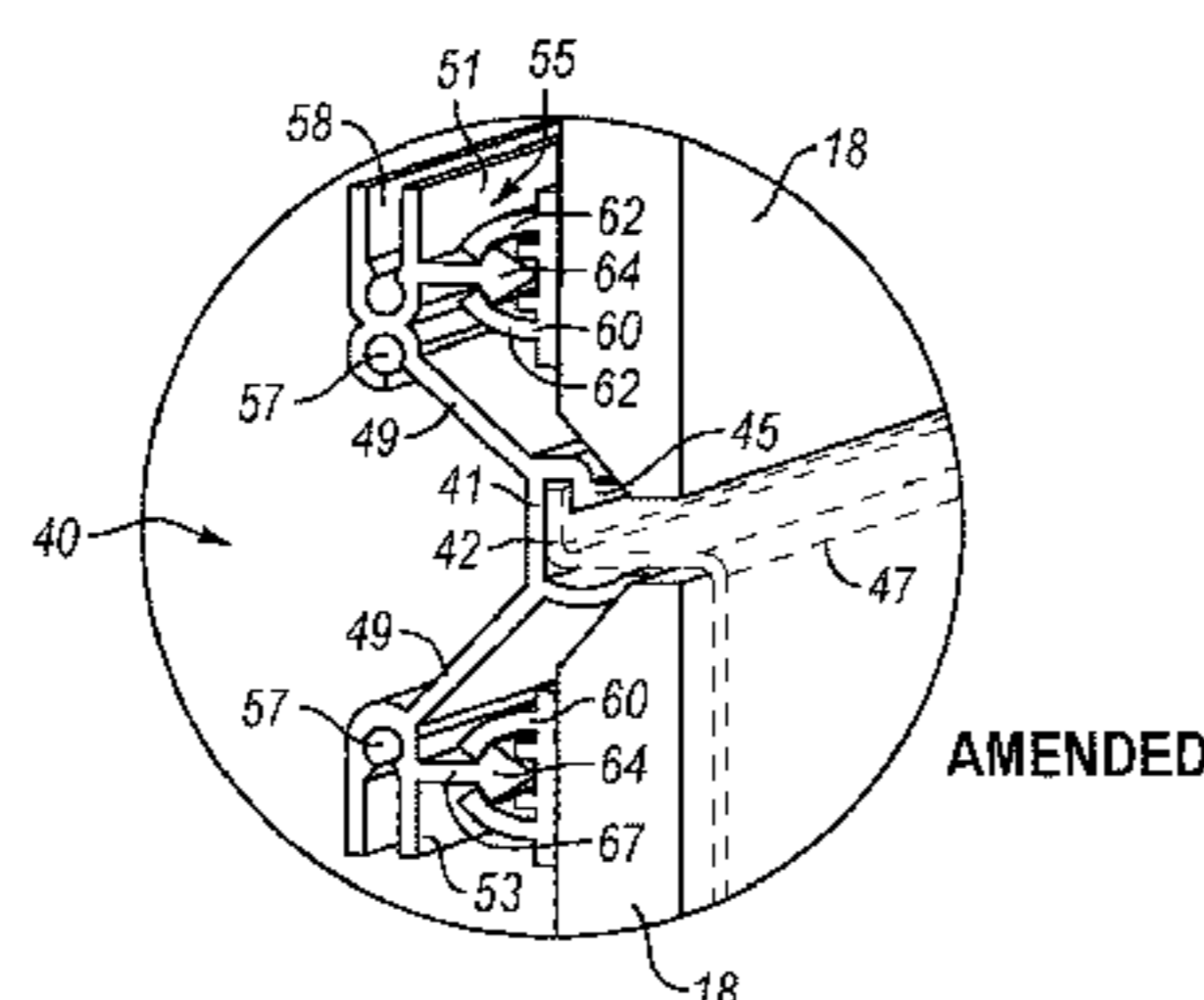

AMENDED

US RE48,722 E

(52)	U.S. Cl. CPC E04B 2002/7462 (2013.01); E04B 2002/7483 (2013.01)	5,125,201 A D327,794 S 5,132,681 A D328,680 S 5,144,777 A D330,295 S 5,155,955 A D330,641 S D330,643 S 5,159,793 A D331,335 S D331,513 S 5,171,060 A 5,172,530 A 5,184,441 A 5,204,149 A 5,207,037 A 5,218,799 A D337,003 S 5,227,005 A 5,247,773 A 5,277,005 A 5,301,484 A 5,321,579 A D348,786 S 5,351,452 A 5,352,033 A * 5,394,668 A 5,488,808 A D371,683 S 5,544,593 A 5,592,794 A 5,598,674 A 5,600,926 A * 5,601,348 A 5,640,297 A 5,642,593 A * 5,669,314 A 5,685,113 A 5,740,644 A 5,740,650 A 5,740,744 A 5,746,035 A 5,778,612 A 5,792,541 A D397,880 S D398,464 S 5,802,789 A 5,803,146 A 5,806,261 A 5,813,178 A * 5,820,991 A 5,822,935 A 5,826,385 A 5,836,121 A 5,839,240 A * 5,852,904 A 5,860,255 A 5,864,997 A 5,870,867 A 5,875,596 A 5,881,979 A 5,913,787 A * 5,931,429 A 5,950,386 A 5,978,988 A 6,012,258 A 6,029,418 A 6,047,508 A 6,058,667 A 6,094,872 A 6,112,472 A 6,122,871 A 6,128,877 A 6,134,845 A 6,141,926 A 6,158,179 A * 6,161,347 A 6,189,270 B1	6/1992 Pieters et al. 7/1992 Zapf 7/1992 Yabe et al. 8/1992 Zapf 9/1992 Fishel 10/1992 Zapf 10/1992 Ball 11/1992 Zapf 11/1992 Zapf 11/1992 Deugo 12/1992 Zapf 12/1992 Zapf 12/1992 Kaye 12/1992 Fishel 2/1993 Balfanz 4/1993 Phenicie 5/1993 Giles 6/1993 Appino 7/1993 Rowland 7/1993 Zodrow et al. 9/1993 Weir 1/1994 Hellwig et al. 4/1994 Jansson 6/1994 Brown 7/1994 Tolleson 10/1994 Gates 10/1994 Gresham et al. 312/312 3/1995 Lim 2/1996 Cahill 7/1996 Tolleson 8/1996 Canfield 1/1997 Tundaun 2/1997 Lay et al. 2/1997 Ehrlich 52/239 2/1997 Minkovski 6/1997 Labaze 7/1997 Shieh 52/239 9/1997 Grant 11/1997 Reuter et al. 4/1998 Menchetti 4/1998 Seiber 4/1998 Nashirozawa 5/1998 Seiber 7/1998 Kissinger et al. 8/1998 Herrera 9/1998 Saul 9/1998 Cronk 9/1998 Goodman 9/1998 Boon 9/1998 Huebner et al. 9/1998 Edwards 52/239 10/1998 Cabo 10/1998 Mitchell 10/1998 Dykstra 11/1998 Hofman 11/1998 Elsholz et al. 52/242 12/1998 Yu 1/1999 Fishel et al. 2/1999 Kelly 2/1999 Mitchell 3/1999 Muller 3/1999 Rozier 6/1999 Edwards 52/220.7 8/1999 Hellwig et al. 9/1999 Shipman 11/1999 Burchett 1/2000 Brown 2/2000 Wright 4/2000 Goodman 5/2000 MacDonald 8/2000 Ward 9/2000 Van Dyk 9/2000 Russell 10/2000 Goodman 10/2000 Shipman 11/2000 Rossiter 12/2000 Ackerly et al. 52/220.7 12/2000 Yu 2/2001 Jeffers
(58)	Field of Classification Search USPC 52/238.1, 239, 242, 243, 243.1, 578, 52/582.1, 474, 476, 481.2, 482, 772, 773, 52/781.3, 126.3; 403/286, 297, 329, 397 See application file for complete search history.		
(56)	References Cited U.S. PATENT DOCUMENTS 2,676,481 A 4/1954 Hoffman 3,037,593 A 6/1962 Webster 3,088,127 A 5/1963 Charles 3,180,457 A 4/1965 Bohnsack 3,251,169 A 5/1966 Cornelissen 3,295,283 A 1/1967 Griffith et al. 3,371,454 A 3/1968 Anderson 3,486,287 A 12/1969 Guillon 3,521,937 A 7/1970 Buhmaster 3,602,226 A 9/1971 Ericson 3,603,053 A 9/1971 Loghem et al. 3,621,635 A 11/1971 Lange 3,675,382 A 7/1972 Lickliter 3,696,569 A 10/1972 Didry 3,751,127 A 8/1973 Pospisil et al. 3,852,148 A 12/1974 Pryor et al. 3,854,269 A 12/1974 Hancock 3,866,364 A 2/1975 Pollard 3,869,198 A 3/1975 Ballentine 3,885,361 A 5/1975 De Schutter 4,027,878 A 6/1977 Dadbeh 4,031,680 A 6/1977 Stoakes 4,052,832 A 10/1977 Jungers et al. 4,065,904 A 1/1978 Taylor et al. 4,101,231 A 7/1978 Streib 4,103,373 A 8/1978 Luedtke 4,128,983 A 12/1978 Matsubara 4,142,342 A 3/1979 Jungers et al. 4,277,920 A 7/1981 Dixon 4,337,997 A 7/1982 Sadoune et al. 4,356,672 A 11/1982 Beckman et al. 4,438,614 A 3/1984 Raith 4,449,337 A 5/1984 Gzym 4,493,172 A * 1/1985 Jones 52/282.2 4,535,577 A 8/1985 Tenser 4,544,300 A 10/1985 Lew et al. 4,556,598 A 12/1985 Bloom et al. 4,600,975 A 7/1986 Roberts 4,631,881 A 12/1986 Charman 4,648,231 A 3/1987 Laroche 4,652,170 A 3/1987 Lew 4,663,228 A 5/1987 Bolton et al. 4,688,491 A 8/1987 Herrera 4,689,262 A 8/1987 Bloom 4,752,101 A 6/1988 Yurchenco 4,757,657 A 7/1988 Mitchell 4,830,080 A 5/1989 Densen D302,497 S 8/1989 Zapf D309,381 S 7/1990 Buhk D309,382 S 7/1990 Randall D309,384 S 7/1990 Buhk D309,385 S 7/1990 Buhk D309,386 S 7/1990 Buhk 4,991,365 A 2/1991 Jackson 5,038,539 A * 8/1991 Kelley et al. 52/239 5,056,285 A 10/1991 Frascaroli D321,801 S 11/1991 Friedman 5,064,247 A 11/1991 Clark 5,067,294 A 11/1991 McGowan 5,067,543 A 11/1991 Bove D323,251 S 1/1992 Zapf 5,086,597 A 2/1992 Kelley D325,309 S 4/1992 Worrell 5,117,599 A 6/1992 Voss		

(56)	References Cited	7,661,237 B2 *	2/2010	Jakob-Bamberg et al.	52/506.08
	U.S. PATENT DOCUMENTS	7,707,790 B2	5/2010	Williams	
		7,818,932 B2	10/2010	Eberlein	
		7,827,745 B2	11/2010	Franceschet	
		7,832,154 B2	11/2010	Gosling	
		7,841,142 B2	11/2010	Towersey	
		7,856,777 B2	12/2010	Lamfers	
		7,861,474 B2	1/2011	Houle	
		7,887,250 B1	2/2011	Wang	
		7,891,148 B2	2/2011	Underwood	
		7,908,805 B2 *	3/2011	Metcalf et al.	52/239
		7,913,459 B2	3/2011	Ball	
		7,918,064 B2	4/2011	Singleton	
		7,922,224 B2	4/2011	Arias	
		7,984,598 B2	7/2011	Gosling	
		8,015,766 B2	9/2011	Gosling	
		8,015,767 B2	9/2011	Glick	
		8,024,901 B2	9/2011	Gosling	
		8,033,059 B2	10/2011	Contois	
		8,033,068 B2	10/2011	Luttman	
		8,046,957 B2	11/2011	Towersey	
		8,151,527 B2	4/2012	Gosling	
		8,151,533 B2	4/2012	Krieger	
		8,176,707 B2	5/2012	Gosling	
		8,215,061 B2	7/2012	Gosling	
		8,272,180 B2	9/2012	Glick	
		8,307,591 B2	11/2012	Steinle	
		8,322,102 B2	12/2012	Krieger	
		8,393,122 B2	3/2013	Henriott	
		8,441,782 B2	5/2013	Thomas	
		8,474,193 B2	7/2013	Sutton	
		8,479,026 B2	7/2013	Lakshmanan	
		8,534,021 B2 *	9/2013	Liu et al.	52/481.2
		8,601,749 B2	12/2013	Von Hoyningen Huene	
		8,613,168 B2	12/2013	Von Hoyningen Huene	
		8,615,936 B2	12/2013	Von Hoyningen Huene	
		8,656,648 B2	2/2014	Liegeois	
		8,683,745 B2	4/2014	Artwohl	
		8,729,446 B2	5/2014	Verfuert	
		D710,025 S	7/2014	Johnson	
		8,910,435 B2	12/2014	Feldpausch	
		D725,638 S	3/2015	Hofman	
		8,966,839 B2	3/2015	Rebman	
		9,003,731 B2	4/2015	Gosling	
		D731,833 S	6/2015	Fifield	
		9,084,489 B2	7/2015	Gosling	
		9,206,600 B2	12/2015	Von Hoyningen Huene	
		9,284,729 B2	3/2016	Von Hoyningen Huene	
		9,562,354 B2	2/2017	Strassle et al.	
		10,016,056 B2	7/2018	Sklansky	
		2001/0039774 A1	11/2001	Beirise	
		2002/0053174 A1 *	5/2002	Barmak	52/220.7
		2002/0104271 A1	8/2002	Gallant	
		2002/0108330 A1 *	8/2002	Yu et al.	52/238.1
		2002/0121056 A1	9/2002	Von Hoyningen	
		2002/0124514 A1	9/2002	Higgins	
		2002/0129574 A1	9/2002	Newhouse	
		2002/0144476 A1	10/2002	Mastelli	
		2002/0157335 A1	10/2002	Vos	
		2003/0005514 A1	1/2003	Kunkel	
		2003/0060080 A1	3/2003	Rees	
		2003/0089057 A1 *	5/2003	Wiechecki et al.	52/238.1
		2003/0154673 A1	8/2003	Macgregor	
		2003/0163967 A1	9/2003	Sims	
		2003/0193709 A1	10/2003	Mallya et al.	
		2003/0196388 A1	10/2003	Edwards	
		2003/0221384 A1	12/2003	Burken et al.	
		2004/0010998 A1	1/2004	Turco	
		2004/0020137 A1 *	2/2004	Batthey et al.	52/36.1
		2004/0035074 A1	2/2004	Stanescu et al.	
		2004/0093805 A1	5/2004	Underwood	
		2004/0139677 A1	7/2004	Mulas et al.	
		2004/0177573 A1 *	9/2004	Newhouse et al.	52/239
		2005/0005527 A1	1/2005	Metcalf	
		2005/0086871 A1	4/2005	MacGregor	
		2006/0042141 A1	3/2006	Hansen	
		2006/0048457 A1	3/2006	Yang	
		2006/0050063 A1	3/2006	Tanabe et al.	
	6,195,953 B1	3/2001	Gitter et al.		
	6,223,485 B1	5/2001	Beck		
	6,250,020 B1	6/2001	Shipman		
	6,250,032 B1 *	6/2001	Davis et al.	52/239	
	6,260,321 B1 *	7/2001	Rudduck	52/474	
	6,282,854 B1 *	9/2001	Vos et al.	52/239	
	6,295,764 B1	10/2001	Berrdige		
	6,301,846 B1	10/2001	Waalkes		
	6,311,441 B1	11/2001	Beavers		
	6,330,773 B1	12/2001	MacDonald		
	6,341,457 B1 *	1/2002	Aerts et al.	52/239	
	6,363,663 B1	4/2002	Kane		
	6,367,215 B1	4/2002	Laing		
	6,393,782 B1	5/2002	Berrdige		
	6,393,783 B2	5/2002	Emaus		
	6,397,533 B1 *	6/2002	Hornberger et al.	52/239	
	6,397,537 B2	6/2002	Auer et al.		
	6,415,567 B1	7/2002	Mead		
	6,446,396 B1	9/2002	Marangoni		
	6,446,404 B1	9/2002	Bassin		
	6,481,168 B1 *	11/2002	Hodges et al.	52/220.7	
	6,484,465 B2	11/2002	Higgins		
	6,490,154 B2	12/2002	Thompson		
	6,497,075 B1	12/2002	Schreiner		
	6,530,181 B1	3/2003	Seiber		
	6,536,175 B2	3/2003	Conterno		
	6,557,310 B2	5/2003	Marshall		
	6,571,855 B1	6/2003	Goldsmith		
	6,581,344 B1	6/2003	Niewiadomski		
	6,591,563 B2	7/2003	King		
	6,612,077 B2	9/2003	Parshad		
	6,615,556 B2	9/2003	Cates et al.		
	6,619,008 B1	9/2003	Shivak		
	6,658,805 B1	12/2003	Yu		
	6,668,514 B2	12/2003	Skov		
	D485,096 S	1/2004	Overthun		
	6,684,929 B2	2/2004	MacDonald		
	6,688,056 B2	2/2004	Von Hoyningen Huene		
	6,701,677 B2	3/2004	Gresham		
	6,711,871 B2	3/2004	Beirise		
	6,729,085 B2	5/2004	Newhouse		
	6,735,908 B2 *	5/2004	Edwards	52/36.1	
	6,748,710 B2	6/2004	Gresham		
	6,761,004 B2	7/2004	Anglin et al.		
	6,775,953 B2	8/2004	Burken		
	6,799,404 B2	10/2004	Spransy		
	6,807,776 B2	10/2004	Girdwood		
	6,820,388 B2	11/2004	Newhouse		
	6,851,226 B2	2/2005	MacGregor		
	6,865,853 B2	3/2005	Burken		
	6,883,277 B2	4/2005	Wiechecki		
	6,889,477 B1	5/2005	Kottman		
	6,920,727 B2 *	7/2005	Yu et al.	52/239	
	6,928,785 B2	8/2005	Shipman		
	6,941,716 B2	9/2005	Kottman		
	6,944,993 B1	9/2005	Jilk		
	6,951,085 B2	10/2005	Hodges		
	6,964,138 B2	11/2005	Carroll		
	6,981,454 B2	1/2006	Burdick		
	6,990,909 B2	1/2006	Gosling		
	6,993,875 B2	2/2006	Rudduck		
	7,051,482 B2	5/2006	MacDonald		
	7,150,127 B2	12/2006	Underwood		
	7,210,270 B1	5/2007	King		
	7,268,311 B2	9/2007	Tanabe et al.		
	7,310,918 B1 *	12/2007	Reuter et al.	52/220.7	
	7,434,790 B1	10/2008	Hansen		
	7,451,577 B2 *	11/2008	Little, Jr.	52/481.2	
	7,461,484 B2	12/2008	Batthey		
	7,540,115 B2	6/2009	Metcalf		
	7,562,504 B2	7/2009	Herbst		
	7,603,821 B2	10/2009	Eberlein		
	7,644,552 B2	1/2010	Kuipers		
	7,645,954 B2	1/2010	Yasuda		

(56)

References Cited

U.S. PATENT DOCUMENTS

2006/0059806	A1	3/2006	Gosling et al.	CA	2430163	A1	7/2002
2006/0080939	A1	4/2006	Bledsoe et al.	CA	2348060		11/2002
2006/0097989	A1	5/2006	Ho	CA	2359165		4/2003
2006/0185276	A1	8/2006	Pai	CA	2310869		8/2003
2006/0210755	A1	9/2006	Blazek	CA	2476368		1/2006
2007/0077387	A1	4/2007	Riccobene	CA	2428593		8/2007
2007/0277449	A1	12/2007	Burns	CA	2359547		2/2008
2007/0289225	A1	12/2007	Kern	CA	2591176		12/2008
2008/0069632	A1	3/2008	Gosling	CA	2634407		12/2008
2008/0168930	A1	7/2008	Calero	CA	2349964		10/2009
2008/0295426	A1	12/2008	Milligan	CA	2840843		12/2013
2008/0302054	A1	12/2008	Gosling	CA	2535213		4/2014
2009/0021122	A1	1/2009	Green	CA	2863783		4/2014
2009/0241437	A1	10/2009	Steinle	CH	686795		6/1996
2009/0260311	A1	10/2009	Boyer	CN	202069245		12/2011
2009/0272056	A1	11/2009	Koupal	DE	1659015		11/1971
2009/0293406	A1	12/2009	Gosling	DE	4207753		9/1993
2009/0324962	A1	12/2009	Manetti	DE	69316247		7/1998
2010/0002298	A1	1/2010	Sugino et al.	DE	19960535		6/2001
2010/0022998	A1	1/2010	Arai et al.	DE	202004017808		1/2005
2010/0043142	A1	2/2010	Whitford	EP	0443202		8/1991
2010/0050548	A1	3/2010	Krieger	EP	0657595	A1	6/1995
2010/0067969	A1	3/2010	Kang	EP	0557092		1/1998
2010/0102960	A1	4/2010	Simon et al.	EP	0886016	A1	12/1998
2010/0192511	A1	8/2010	Gosling	EP	0963719		12/1999
2010/0223857	A1	9/2010	Sutton	EP	1035264	A1	9/2000
2010/0236173	A1	9/2010	Pacha et al.	EP	1094167		4/2001
2010/0287858	A1	11/2010	Israeli et al.	EP	2736382	A1	6/2014
2010/0307086	A1	12/2010	Hibbs	FR	1526637		5/1968
2011/0113692	A1	5/2011	Stamper	FR	2218447	A1	9/1974
2011/0197519	A1	8/2011	Henriott	GB	1013451	A	12/1965
2012/0102844	A1	5/2012	Damo	GB	2221946		2/1990
2012/0141735	A1	6/2012	Chevallier et al.	GB	2283071		4/1995
2012/0186164	A1	7/2012	Pensi	GB	2374612	A	10/2002
2012/0293855	A1	11/2012	Shrivastava et al.	GB	2353541		10/2003
2012/0317899	A1	12/2012	Von Hoyningen Huene	JP	HO3 17333		1/1991
2013/0025220	A1	1/2013	Yu et al.	JP	2003105908		4/2003
2014/0102021	A1	4/2014	Gosling	JP	2005155223		6/2005
2014/0133137	A1	5/2014	Kiss	KR	1020000049102		7/2000
2014/0137495	A1	5/2014	Ariza	KR	1020070077502		7/2007
2014/0157693	A1	6/2014	Schumacher	KR	10-2012-0040541	A	4/2012
2014/0202361	A1	7/2014	Siwiec	KR	10-1311065	B1	9/2013
2014/0310873	A1	10/2014	Gosling	KR	10-1311068	B1	9/2013
2014/0338120	A1	11/2014	Baugh et al.	WO	1259347		1/1972
2014/0338272	A1	11/2014	Shiao et al.	WO	1400613		7/1975
2014/0362050	A1	12/2014	Wilson et al.	WO	0302564		2/1989
2015/0007516	A1	1/2015	Glick	WO	WO9212074		7/1992
2015/0029412	A1	1/2015	Kishioka et al.	WO	WO9212300		7/1992
2015/0118869	A1	4/2015	Brown et al.	WO	WO9315970		8/1993
2015/0211228	A1	7/2015	Smed et al.	WO	WO9323629		11/1993
2015/0343884	A1	12/2015	Rousselet et al.	WO	WO9402695		2/1994
2015/0354212	A1	12/2015	Von Hoyningen Huene	WO	WO9633323		10/1996
2016/0032644	A1	2/2016	Geller	WO	WO9746770		12/1997
2016/0052241	A1	2/2016	Zhang	WO	0557092		1/1998
2016/0053485	A1	2/2016	Von Hoyningen Huene	WO	WO9807357		2/1998
2016/0071664	A1	3/2016	Cohen et al.	WO	98/16870	A1	4/1998
2016/0168863	A1	6/2016	Kwan et al.	WO	WO9816699		4/1998
2016/0282983	A1	9/2016	Chang et al.	WO	WO9829623		7/1998
2016/0348361	A1	12/2016	Gosling et al.	WO	WO9837292		8/1998
2017/0038896	A1	2/2017	Lee et al.	WO	WO9851876		11/1998
2017/0089066	A1	3/2017	Gosling et al.	WO	WO9946453		9/1999
2018/0002924	A1	1/2018	Gosling et al.	WO	WO9946455		9/1999
2018/0195290	A1	7/2018	Seffer et al.	WO	WO9946458		9/1999
				WO	WO9953156		10/1999
				WO	WO9958780		11/1999
				WO	WO9963177		12/1999
				WO	WO0015918		3/2000
				WO	00/52111	A1	9/2000
				WO	00/75440	A1	12/2000
				WO	WO0075447		12/2000
				WO	WO0171241		9/2001
				WO	WO0208851		1/2002
				WO	WO0205211		4/2002
				WO	WO02103129		12/2002
				WO	WO2003071045		8/2003
				WO	WO2003104581		12/2003
				WO	2005/120294	A2	12/2005
				WO	2006/123335	A2	11/2006
				WO	2006127804		11/2006
CA	1294107		11/1987				
CA	2011977		10/1990				
CA	2002674		5/1991				
CA	2040822		11/1991				
CA	2123031	A1	11/1994				
CA	2162300		5/1997				
CA	2248428	A1	3/2000				
CA	2273631		10/2001				
CA	2324050		4/2002				

FOREIGN PATENT DOCUMENTS

(56)

References Cited

FOREIGN PATENT DOCUMENTS

WO	2010121788	10/2010
WO	2011/150467 A1	12/2011
WO	WO2012173930	12/2012
WO	2013/101298 A1	7/2013
WO	WO2013130871	9/2013
WO	WO2013185141	12/2013
WO	WO2013188211	12/2013
WO	WO2013188235	12/2013
WO	2014039278	3/2014
WO	WO2014055883	4/2014
WO	2017/213960 A1	12/2017
WO	2018/009936 A2	1/2018

OTHER PUBLICATIONS

- European Search Report for PCT/US2012/042314 dated Jan. 29, 2015.
- International Search Report and Written Opinion for PCT/US2012/041906 dated Jan. 31, 2013.
- Petition for Inter Partes Review of U.S. Pat. No. 8,024,901, IPR2015-01690, filed Aug. 7, 2015.
- Petition for Inter Partes Review of U.S. Pat. No. 8,024,901, IPR2015-01691, filed Aug. 7, 2015.
- Lifespace Environmental Wall Systems, [Publication Date Unlisted], Dated Apr. 1995.
- Office Insight, [Publication Date Unlisted], Dated Mar. 23, 2009.
- U.S. Specifier Guide and Price Book, [Publication Date Unlisted], Dated Jan. 1998.
- SMED International—Lifespace—Technical Information, [Publication Date Unlisted], Dated Jan. 1, 1996.
- Teknionalto—Price and Product Guide Update, [Publication Date Unlisted], Dated Feb. 2002.
- Office Action for U.S. Appl. No. 14/681,874 dated Jul. 23, 2015.
- Canadian Office Action for Application No. 2,800,414 dated Jul. 15, 2015.
- Final Office Action for U.S. Appl. No. 14/657,837 dated Nov. 2, 2015.
- Patent Owner's Preliminary Response for Case No. IPR2015-01690 Dated Nov. 13, 2015.
- Patent Owner's Preliminary Response for Case No. IPR2015-01691 dated Nov. 18, 2015.
- Notice of Allowance for U.S. Appl. No. 14/657,837 dated Apr. 12, 2016.
- Final Written Decision (IPR2015-01691), *Allsteel v. DIRTT Environmental Solutions* dated Jan. 19, 2017.
- Notice of Allowance for U.S. Appl. No. 29/492,776 dated Jan. 21, 2016.
- Notice of Allowance for U.S. Appl. No. 29/493,280 dated Jan. 21, 2016.
- Decision Denying Institution (IPR2015-01690), *Allsteel v. DIRTT Environmental Solution* dated Jan. 27, 2016.
- Decision Granting Institution (IPR2015-01691), *Allsteel v. DIRTT Environmental Solutions* dated Feb. 2, 2016.
- Non-Final Office Action for U.S. Appl. No. 14/681,874 dated Jun. 15, 2016.
- Restriction Requirement for U.S. Appl. No. 14/683,684 dated Oct. 5, 2017.
- Patent Owner's Response (IPR2015-01691), *Allsteel v. DIRTT Environmental Solutions*, dated Sep. 27, 2011.
- Reply to Patent Owner's Response (IPR2015-01691), *Allsteel v. DIRTT Environmental Solutions*, dated Jul. 21, 2016.
- Petitioner's Supplemental Brief Addressing Newly Instituted Claims 8, 11, 13 and 21-23 (IPR2015-01691), *Allsteel v. DIRTT Environmental Solutions*, dated Oct. 19, 2018.
- Supplemental Declaration of Joseph J. Beaman Jr. (IPR2015-01691), *Allsteel v. DIRTT Environmental Solutions*, dated Oct. 19, 2018.
- Patent Owner's Response to Petitioner's Supplemental Brief Addressing Newly Instituted Claims 8, 11, 13, and 21-23 (IPR2015-01691), *Allsteel v. DIRTT Environmental Solutions*, dated Nov. 28, 2018.
- Exhibit 2010 Oral Deposition of Joseph J. Beaman Jr., Ph.D. (IPR2015-01691), *Allsteel v. DIRTT Environmental Solutions*, dated Nov. 18, 2018.
- Petitioner's Reply to Patent Owner's Responsive Brief (IPR2015-01691), *Allsteel v. DIRTT Environmental Solutions*, dated Dec. 12, 2018.
- Final Written Decision on Remand (IPR2015-01691), *Allsteel v. DIRTT Environmental Solutions*, dated Apr. 22, 2019.
- Expert Declaration of Joseph J. Beaman, Jr., Exhibit No. 1018 (IPR2015-01691), *Allsteel v. DIRTT Environmental Solutions*, dated Aug. 5, 2015.
- Deposition of Joseph J. Beaman, Jr., Exhibit No. 2003 (IPR2015-01691), *Allsteel v. DIRTT Environmental Solutions*, dated Apr. 1, 2016.
- Reply Declaration of Joseph J. Beaman, Jr., Exhibit No. 1032 (IPR2015-01691), *Allsteel v. DIRTT Environmental Solutions*, dated Jul. 21, 2016.
- Declaration of Robert Wittl, Exhibit No. 1033 (IPR2015-01691), *Allsteel v. DIRTT Environmental Solutions*, dated Jul. 21, 2016.
- Non-Final Office Action for U.S. Appl. No. 15/177,084 dated Jan. 29, 2018.
- Non-Final Office Action for U.S. Appl. No. 14/683,684 dated Apr. 23, 2018.
- Notice of Allowance for U.S. Appl. No. 14/683,684 dated Jan. 24, 2020.
- Achieving the Atkins Aesthetic: KI's new ThinLine option for its award-winning Genius Architectural Wall flaunts a slimmer figure, [Publication Date Unlisted], Dated Jun. 14, 2004.
- European Communication pursuant to Article 94(3) EPC for European Application No. 15751602.2, dated Jul. 7, 2020, 4 pages.
- European Communication pursuant to Article 94(3) EPC for European Application No. 15752109.7, dated Jul. 7, 2020, 5 pages.
- European Communication pursuant to Article 94(3) EPC for European Application No. 15752752.4, dated Jul. 7, 2020, 4 pages.
- European Communication pursuant to Article 94(3) EPC for European Application No. 17189630.1, dated Jul. 1, 2019, 13 pages.
- European Communication pursuant to Article 94(3) EPC for European Application No. 17189630.1, dated Dec. 11, 2018, 8 pages.
- European Communication pursuant to Article 94(3) EPC received for European Patent Application No. 15804050.1, dated Jul. 16, 2020, 5 pages.
- European Extended Search Report and Opinion for European Application No. 17189630.1, dated Dec. 1, 2017, 9 pages.
- European Search Report and Search Opinion Received for EP Application No. 15804050.1, dated Dec. 11, 2017, 7 pages.
- European Search Report for PCT/US2015015943, dated Sep. 27, 2017.
- European Search Report, EP 12800672, dated Oct. 10, 2014.
- European Supplementary Search Report and Opinion for European Application No. 15751602.2, dated Dec. 11, 2017, 7 pages.
- European Supplementary Search Report and Opinion for European Application No. 15752109.7, dated Sep. 27, 2017, 8 pages.
- European Supplementary Search Report and Opinion for European Application No. 15752752.4, dated Dec. 11, 2017, 6 pages.
- Final Office Action for U.S. Appl. No. 15/023,990 dated Sep. 7, 2018.
- Final Office Action for U.S. Appl. No. 15/023,990 dated Oct. 3, 2017.
- Final Office Action for U.S. Appl. No. 15/741,180 dated Jan. 23, 2020.
- Final Office Action for U.S. Appl. No. 15/741,180, dated Feb. 21, 2019.
- Final Office Action for U.S. Appl. No. 14/681,874 dated Apr. 15, 2016.
- Genius Architectural Walls, [Publication Date Unlisted], Copyright Date 2004 by KI, Document Code KI-00473/HC/IT/PP/504.
- International Search Report and Written Opinion for application No. PCT/US2016/022634 dated Jun. 29, 2016.
- International Search Report and Written Opinion for application No. PCT/US2017/035520 dated Aug. 18, 2017.

(56)

References Cited

OTHER PUBLICATIONS

International Search Report and Written Opinion for application No. PCT/US2017/041387 dated Oct. 19, 2017.

International Search Report for application No. PCT/US15/015931 dated Apr. 30, 2015.

International Search Report for application No. PCT/US15/015943 dated May 14, 2015.

International Search Report for application No. PCT/US15/15920 dated May 22, 2015.

International Search Report for application No. PCT/US15/34491 dated Sep. 15, 2015.

International Search Report on Patentability Chapter I for application No. PCT/US2016/022634 dated Sep. 19, 2017.

KI Genius Full-Height Moveable Walls, [Publication Date Unlisted], Copyright Date 2003 by KI, Document Code KI-00506/HC/PP/803. KI Improves STC Rating on its Genius Architectural Wall and receives ICC approval, [Publication Date Unlisted], dated Feb. 26, 2004.

Non-Final Office Action for application No. 15/023,990 dated Mar. 15, 2018.

Non-Final Office Action for application No. 15/023,990 dated Mar. 6, 2017.

Non-Final Office Action for application No. 15/038,694 dated Jan. 18, 2018.

Non-Final Office Action for application No. 15/741,180 dated Oct. 5, 2018.

Non-Final Office Action for U.S. Appl. No. 14/305,819, dated Jul. 11, 2017.

Non-Final Office Action for U.S. Appl. No. 15/026,566 dated Sep. 21, 2017.

Non-Final Office Action in U.S. Appl. No. 14/903,035 dated Feb. 16, 2017.

Non-Final Office Action in U.S. Appl. No. 15/177,095 dated Jul. 24, 2017.

Non-Final Office Action received for U.S. Appl. No. 15/026,566, dated Sep. 21, 2020, 15 pages.

Non-Final Office Action received for U.S. Appl. No. 15/741,489, dated Oct. 27, 2020, 7 pages.

Notice of Allowance for U.S. Appl. No. 14/903,035 dated Aug. 14, 2017.

Notice of Allowance for U.S. Appl. No. 15/028,000, dated Jul. 7, 2017.

Notice of Allowance for U.S. Appl. No. 15/177,095 dated Nov. 16, 2017.

Office Action for U.S. Appl. No. 15/741,180, dated May 9, 2019. Press Release~“KI unveils Genius Full Height Movable Wall Microsite with new interactive features”, Accessed on Aug. 14, 2015 at http://web.archive.org/web/20040506230219/http://www.ki.com/about_press_release.asp?id=49_.

Restriction Requirement for U.S. Appl. No. 15/177,084 dated Aug. 18, 2017.

Supplementary European Search Report for application EP 15752752 dated Nov. 30, 2017.

Supplementary Search Report for application EP 15751602 dated Nov. 21, 2017.

Supplementary Search Report for application EP 15804050 dated Nov. 30, 2017.

* cited by examiner

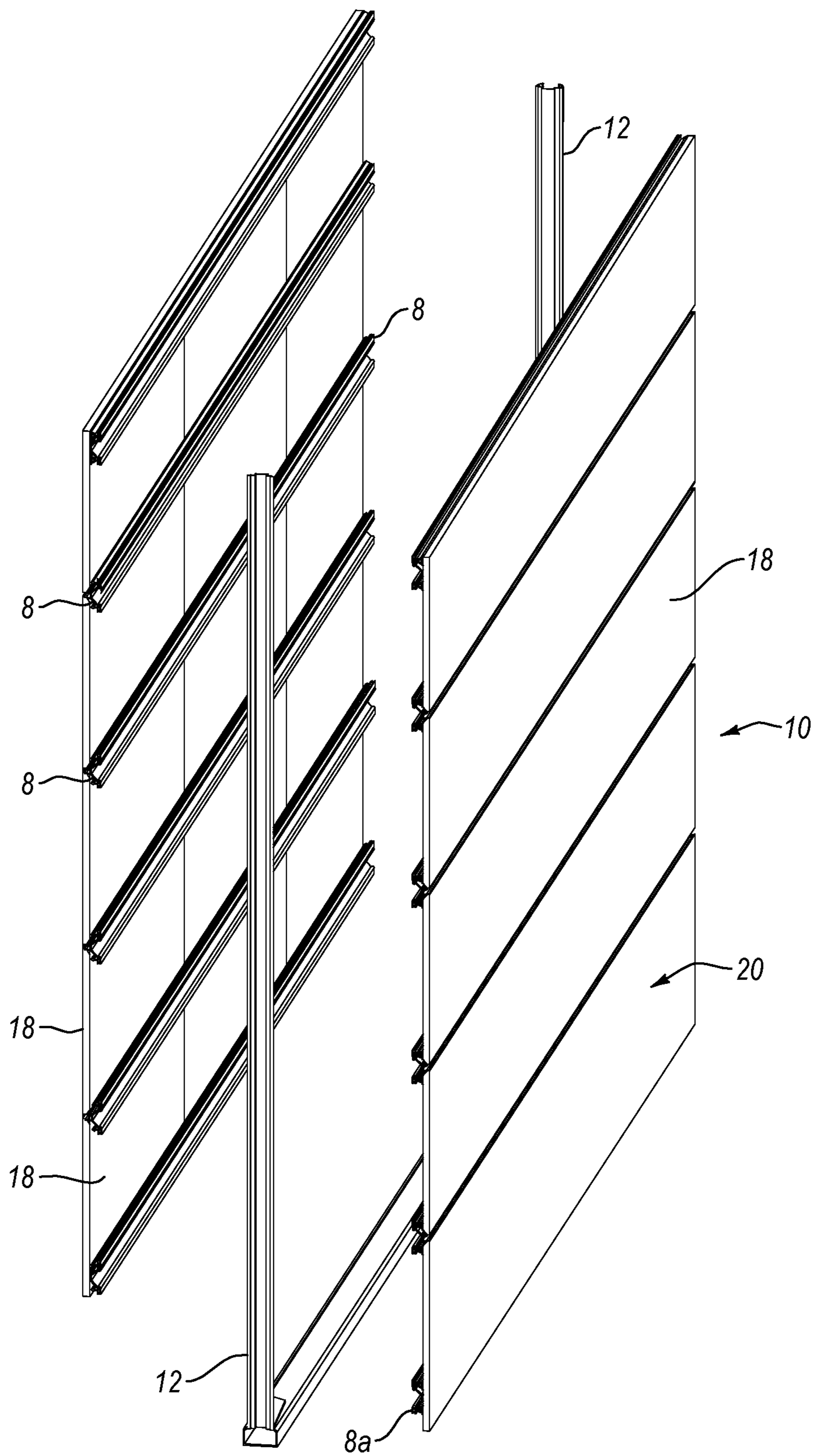

AMENDED
Figure 1

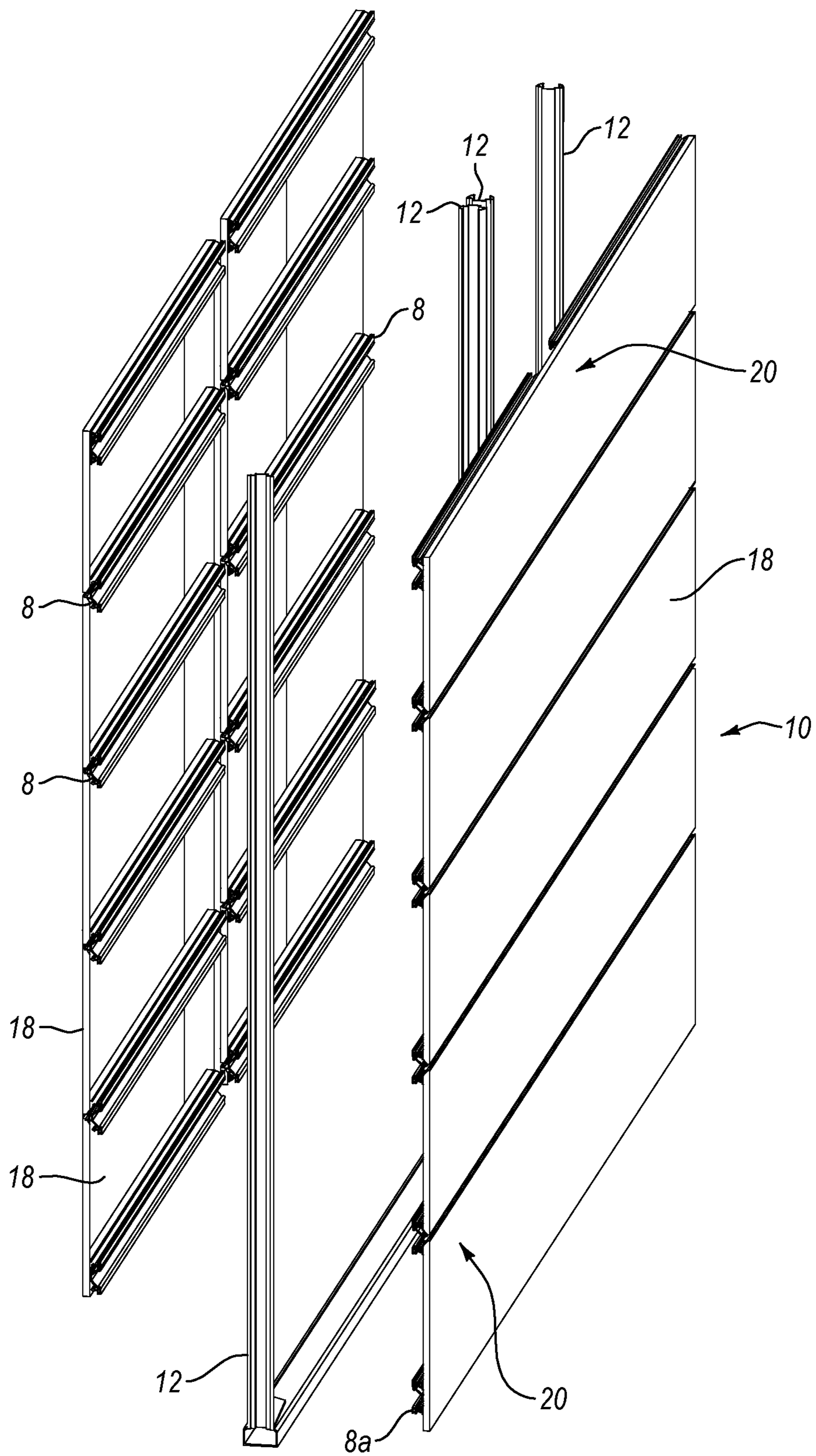

- NEW -
Figure 1A

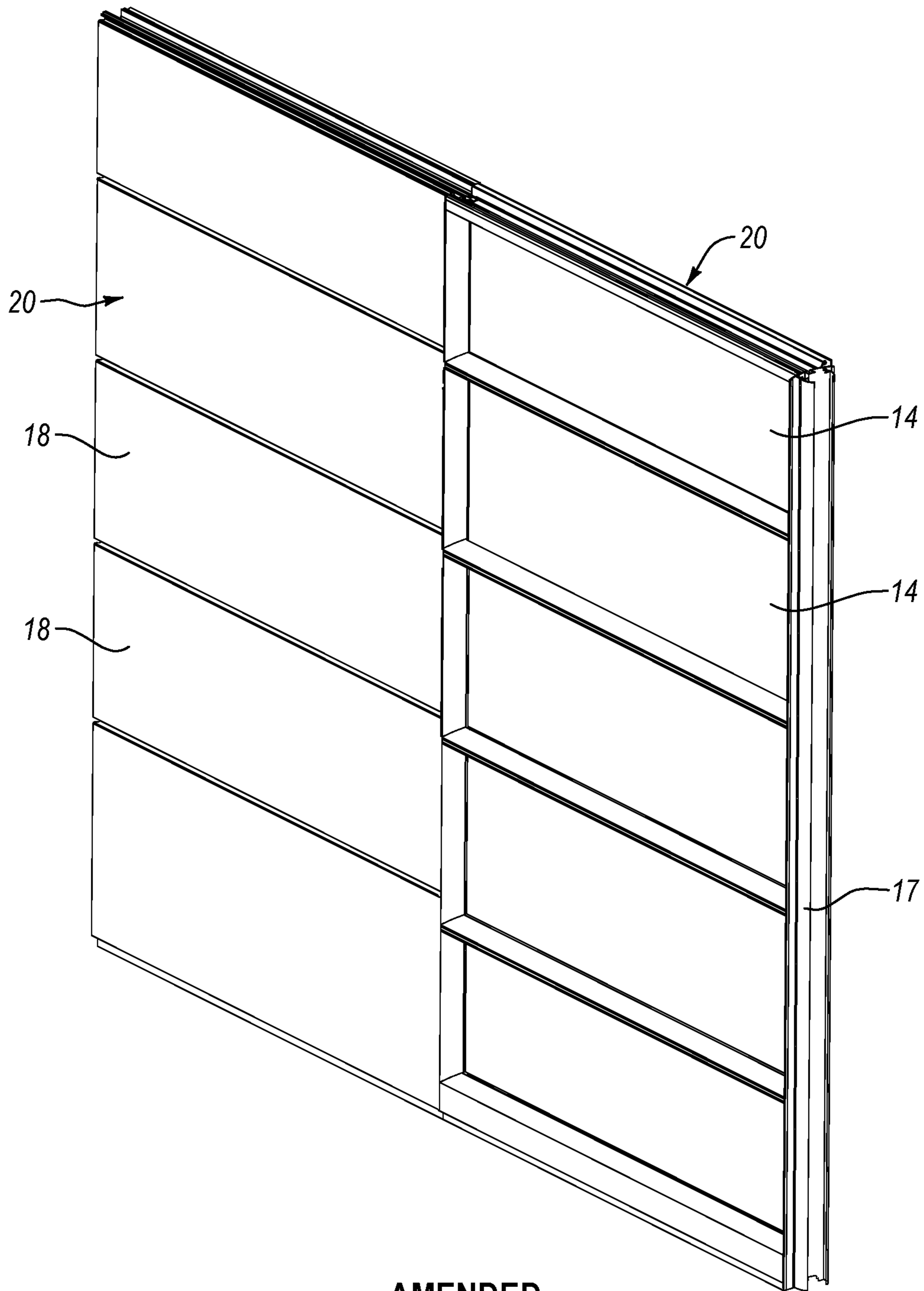

AMENDED
Figure 2

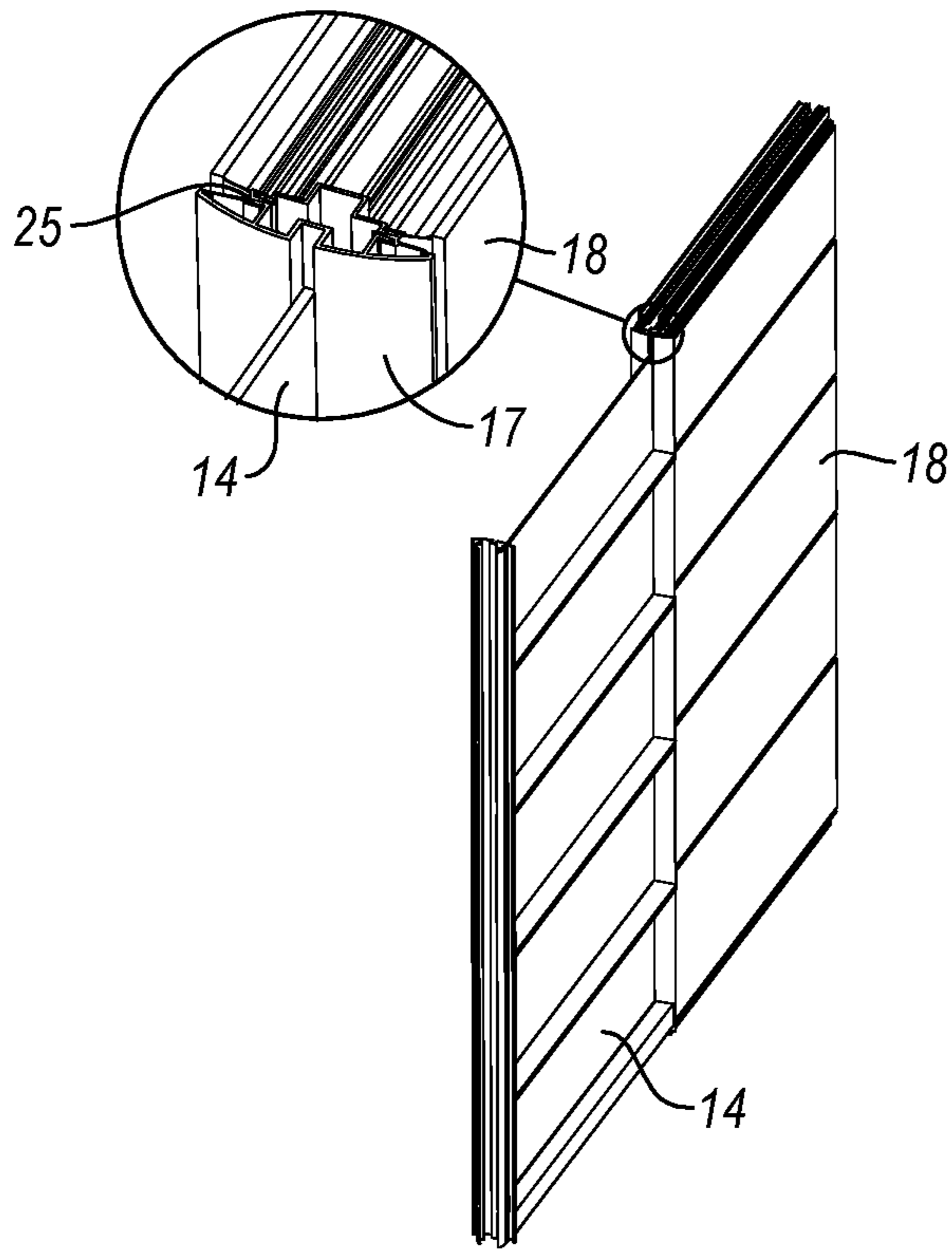
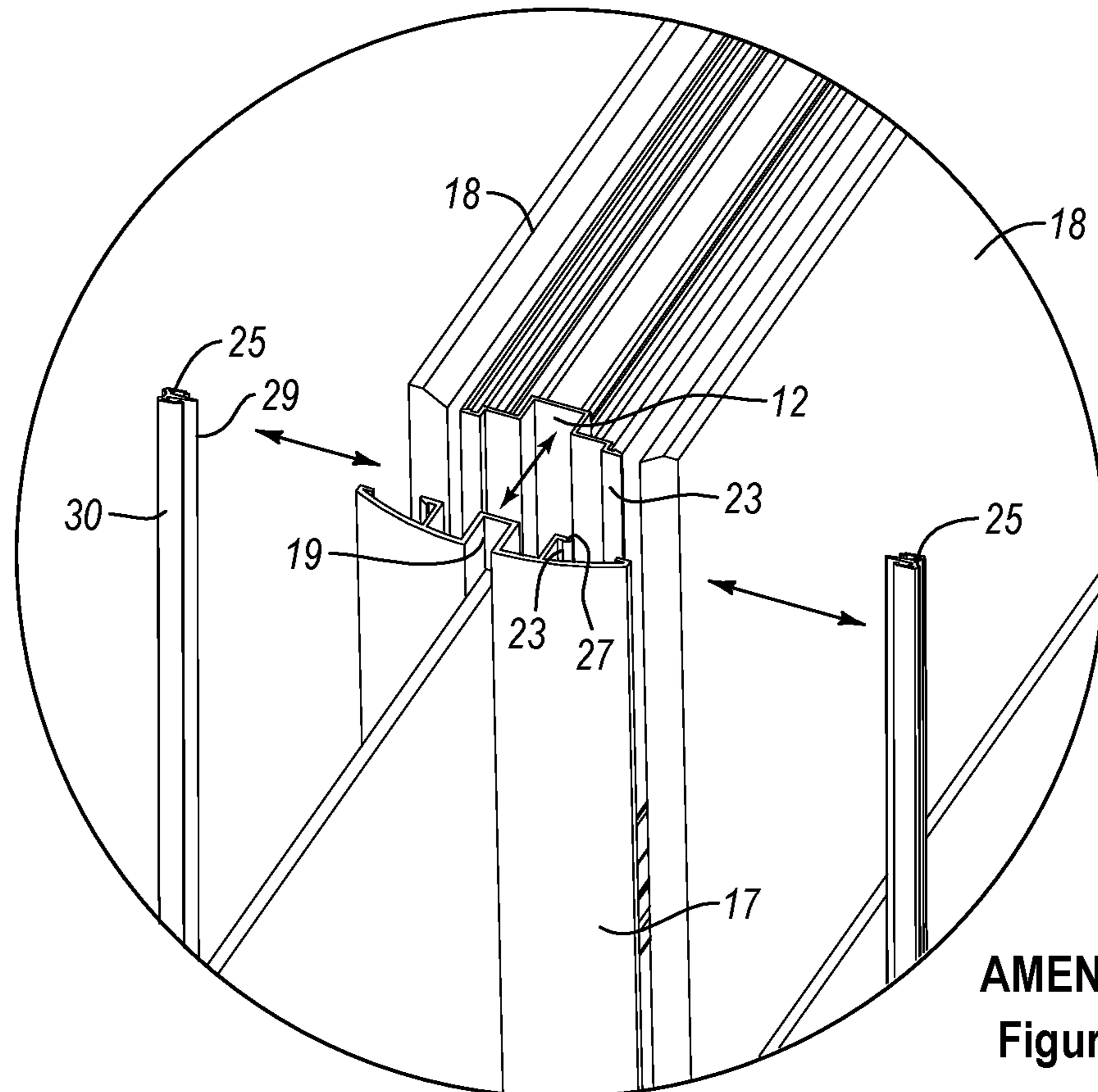

Figure 3



AMENDED
Figure 4

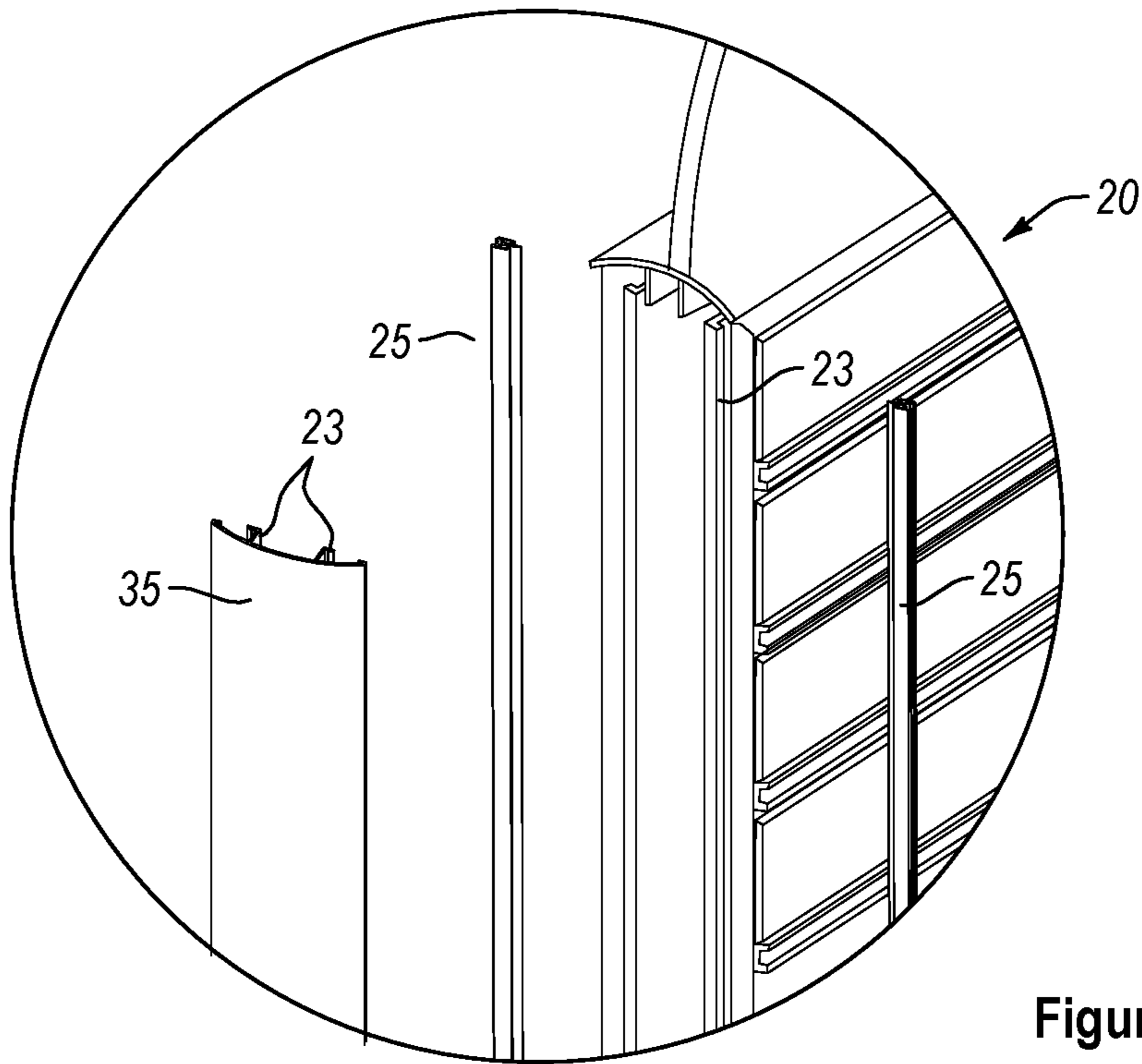
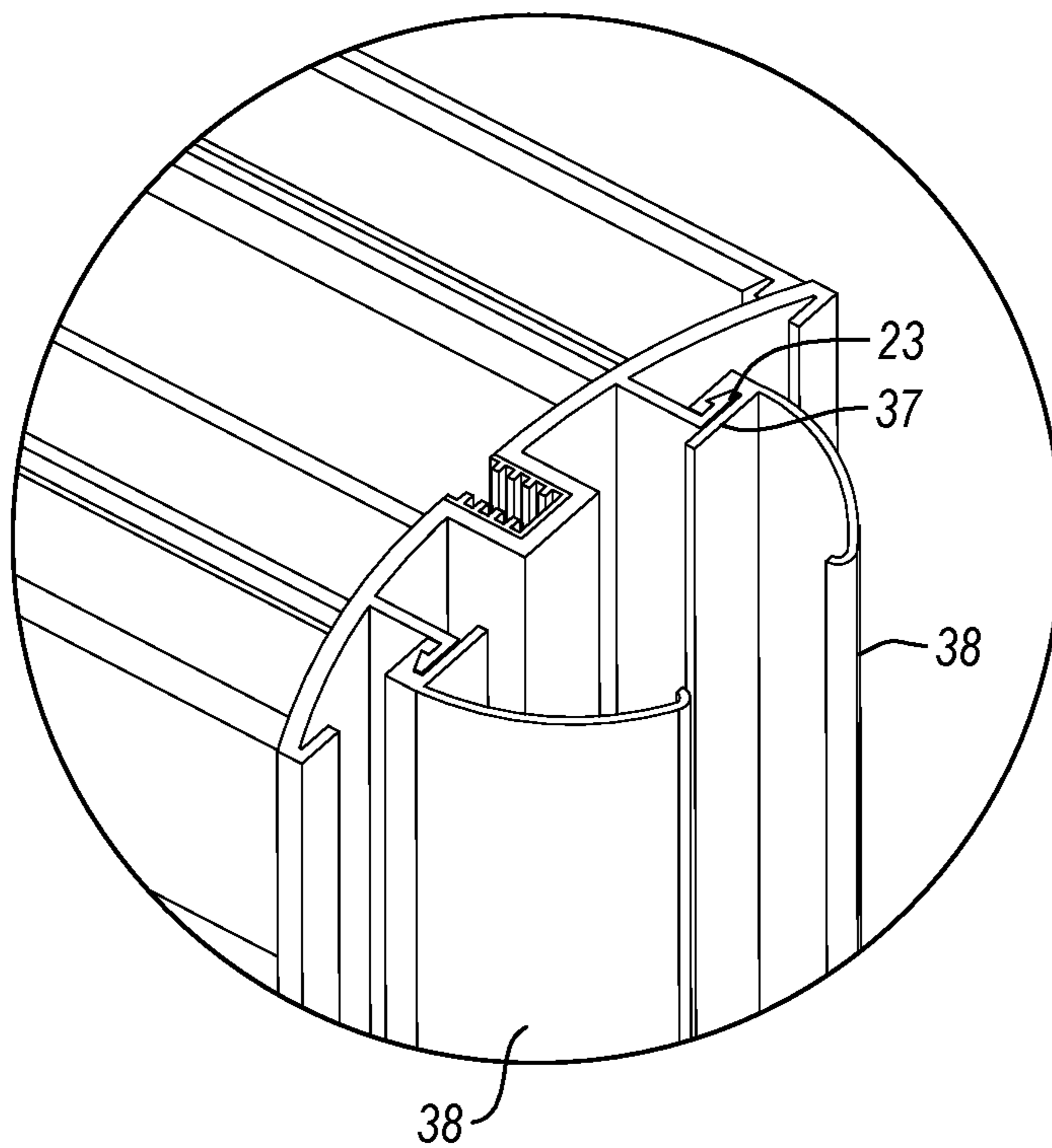
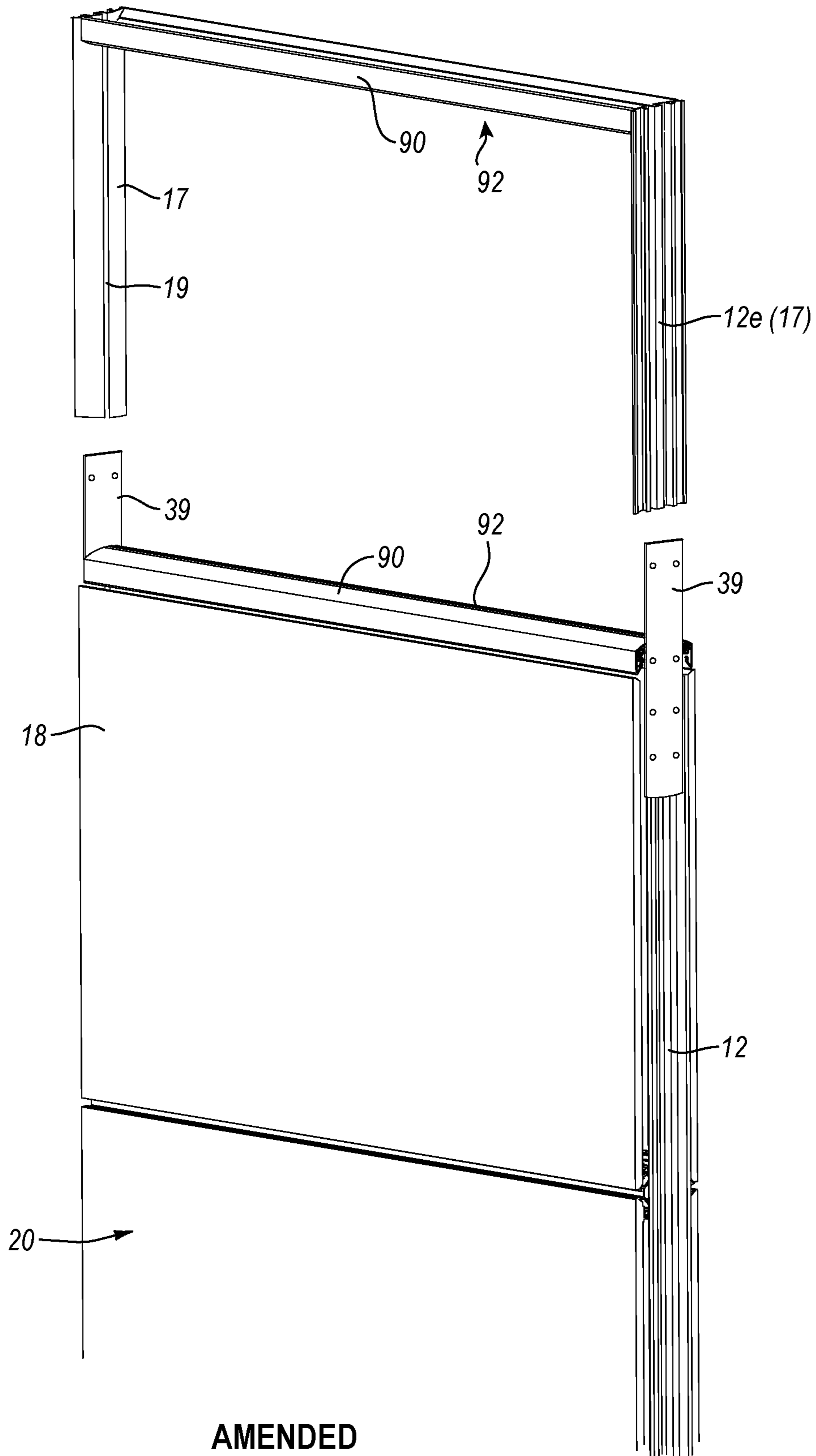

Figure 5



AMENDED
Figure 6



AMENDED
Figure 7

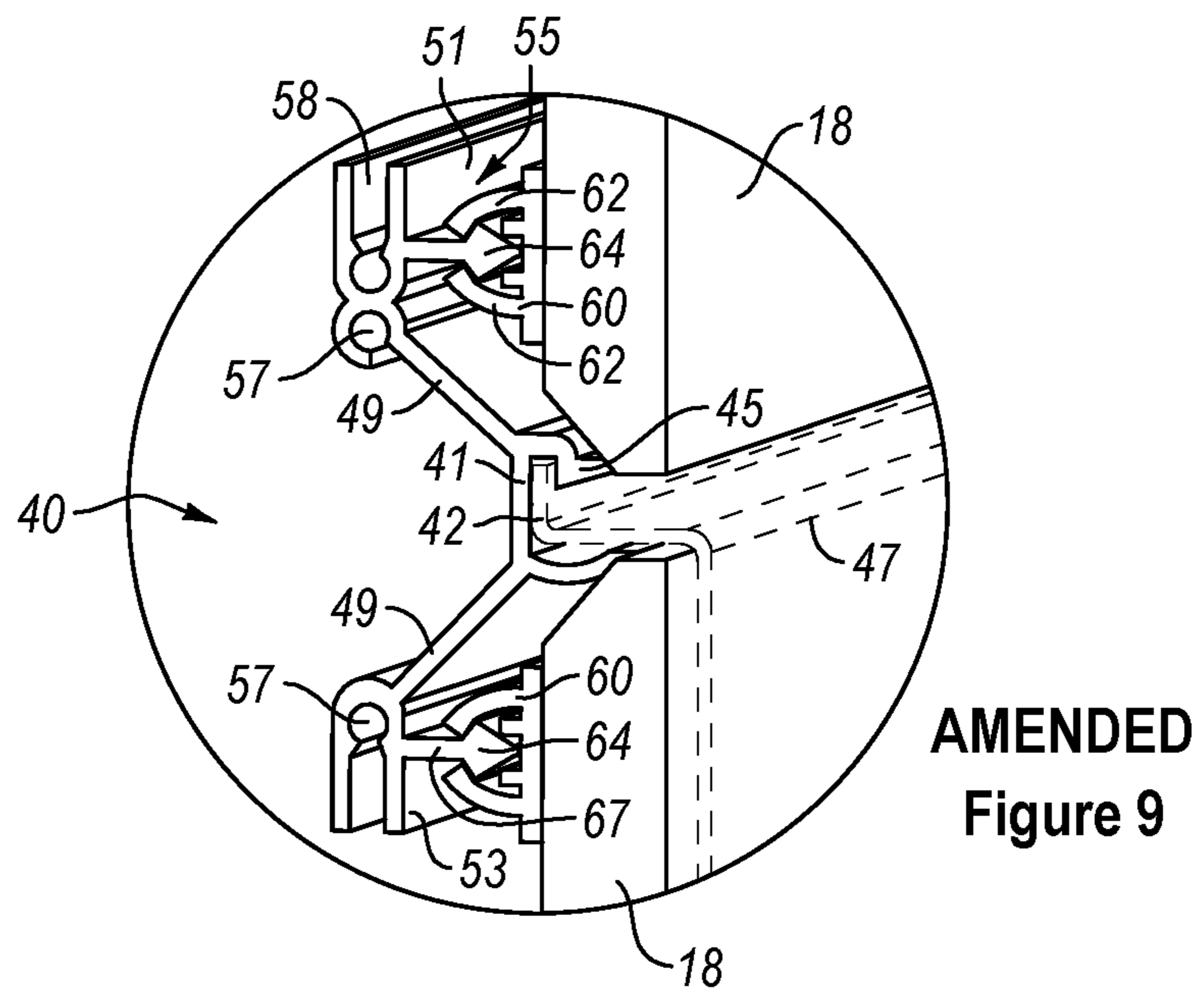
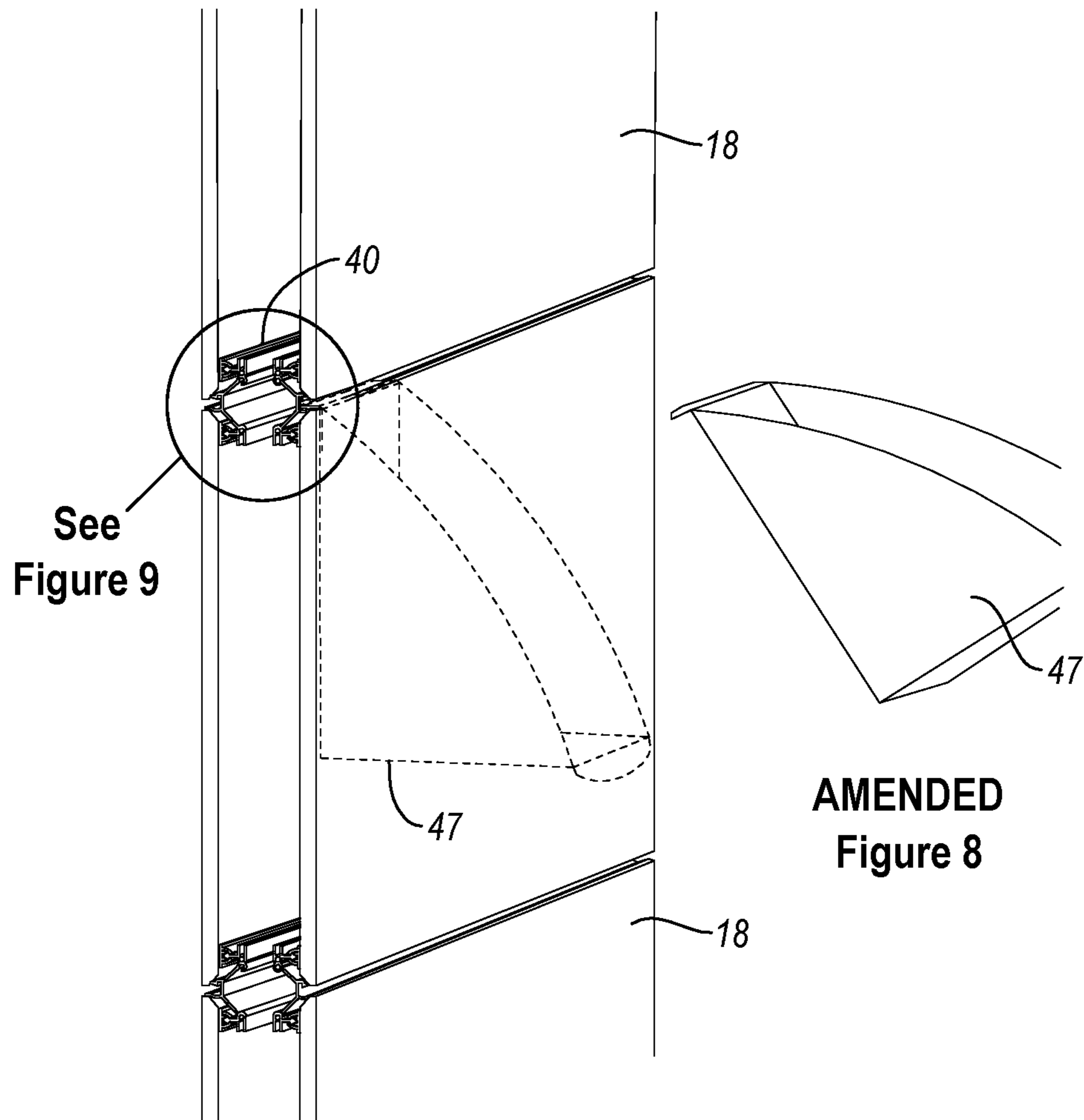

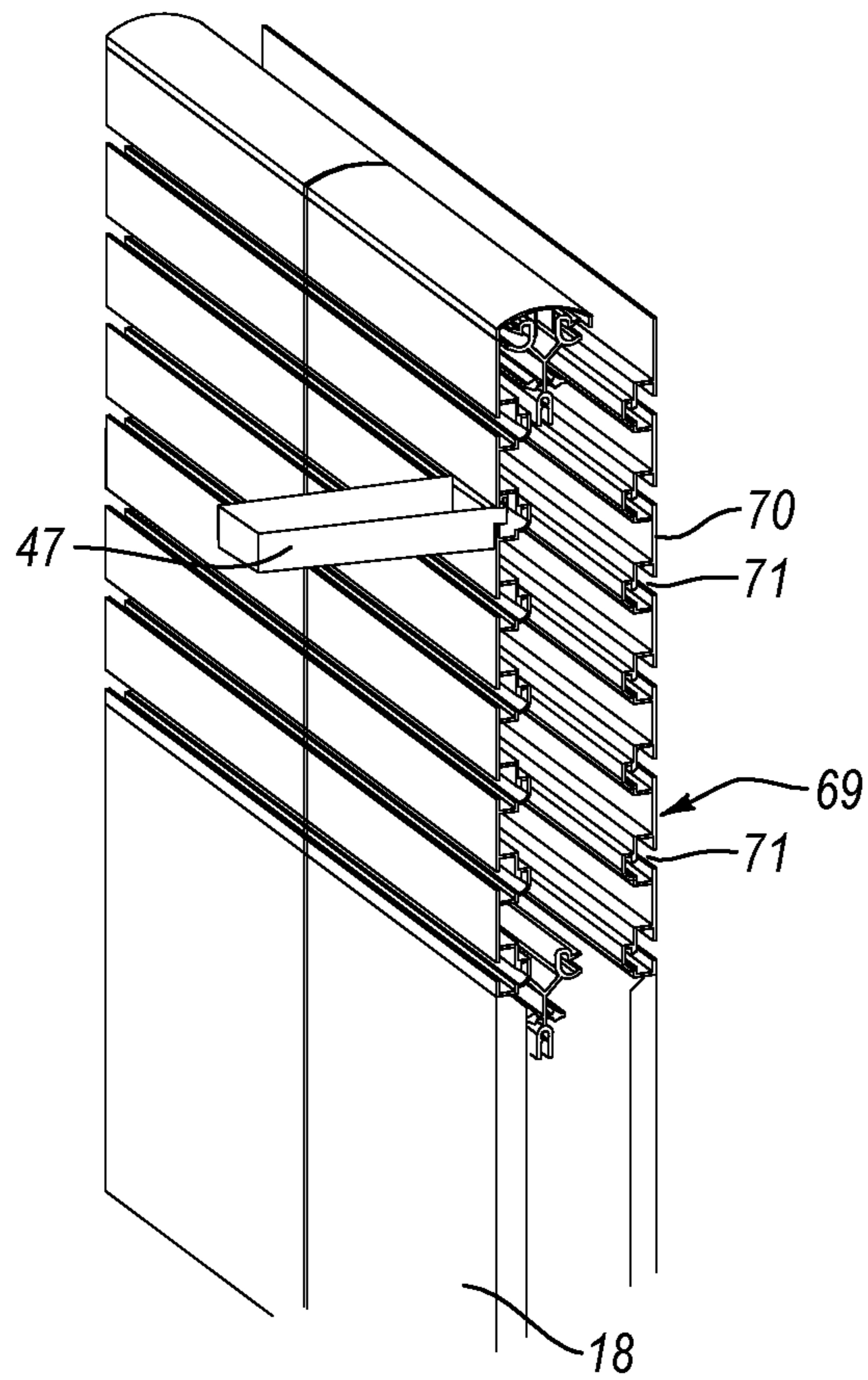

Figure 10

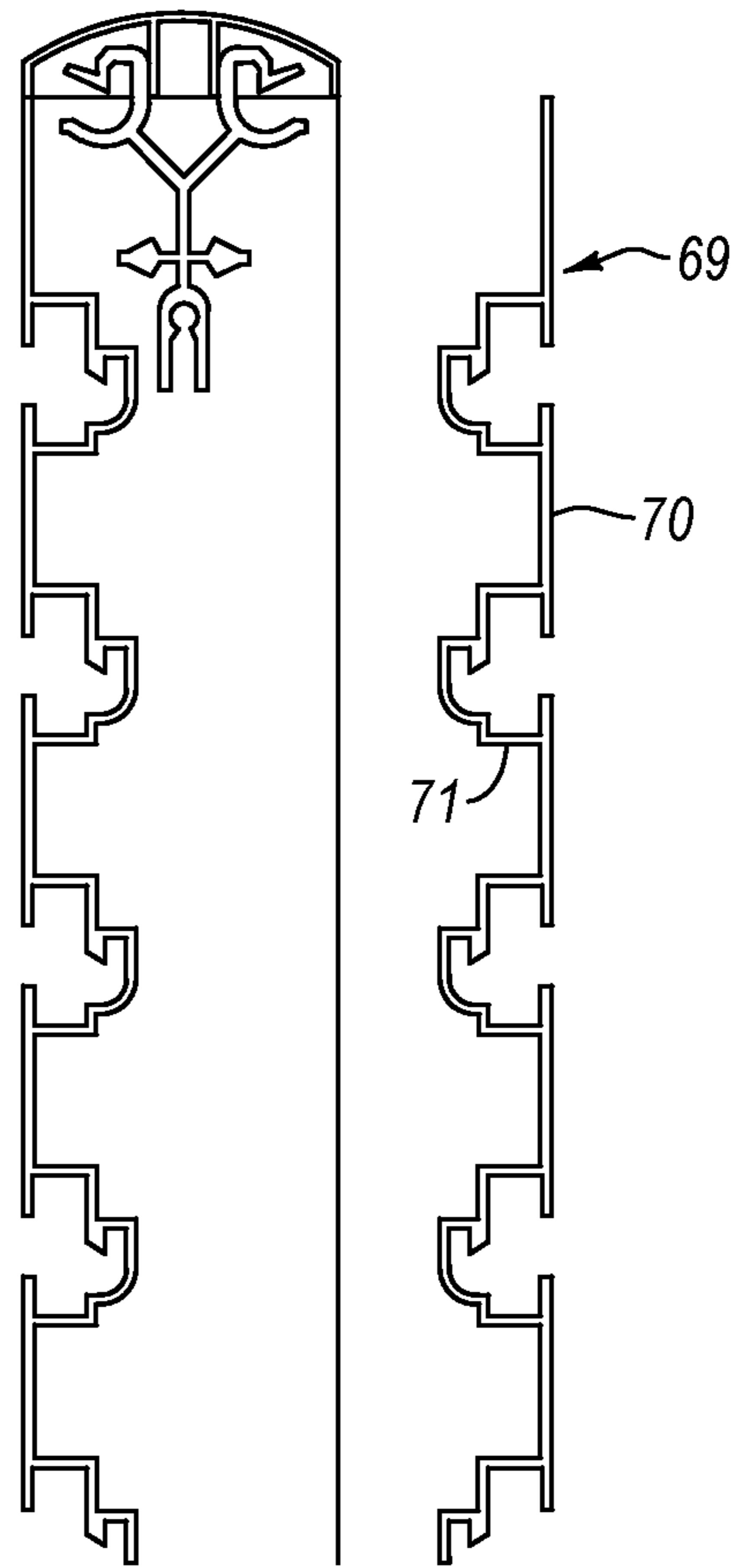

Figure 11

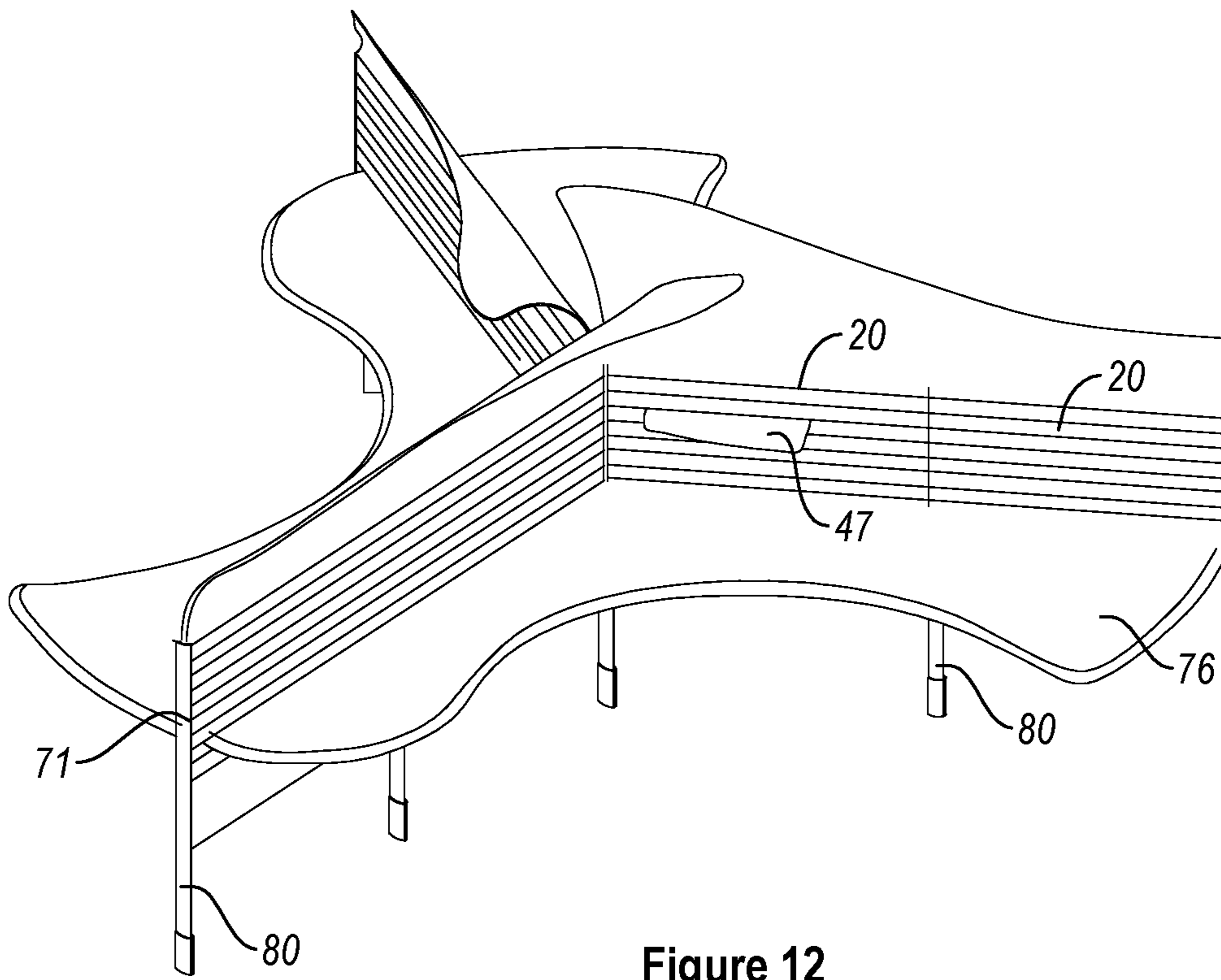
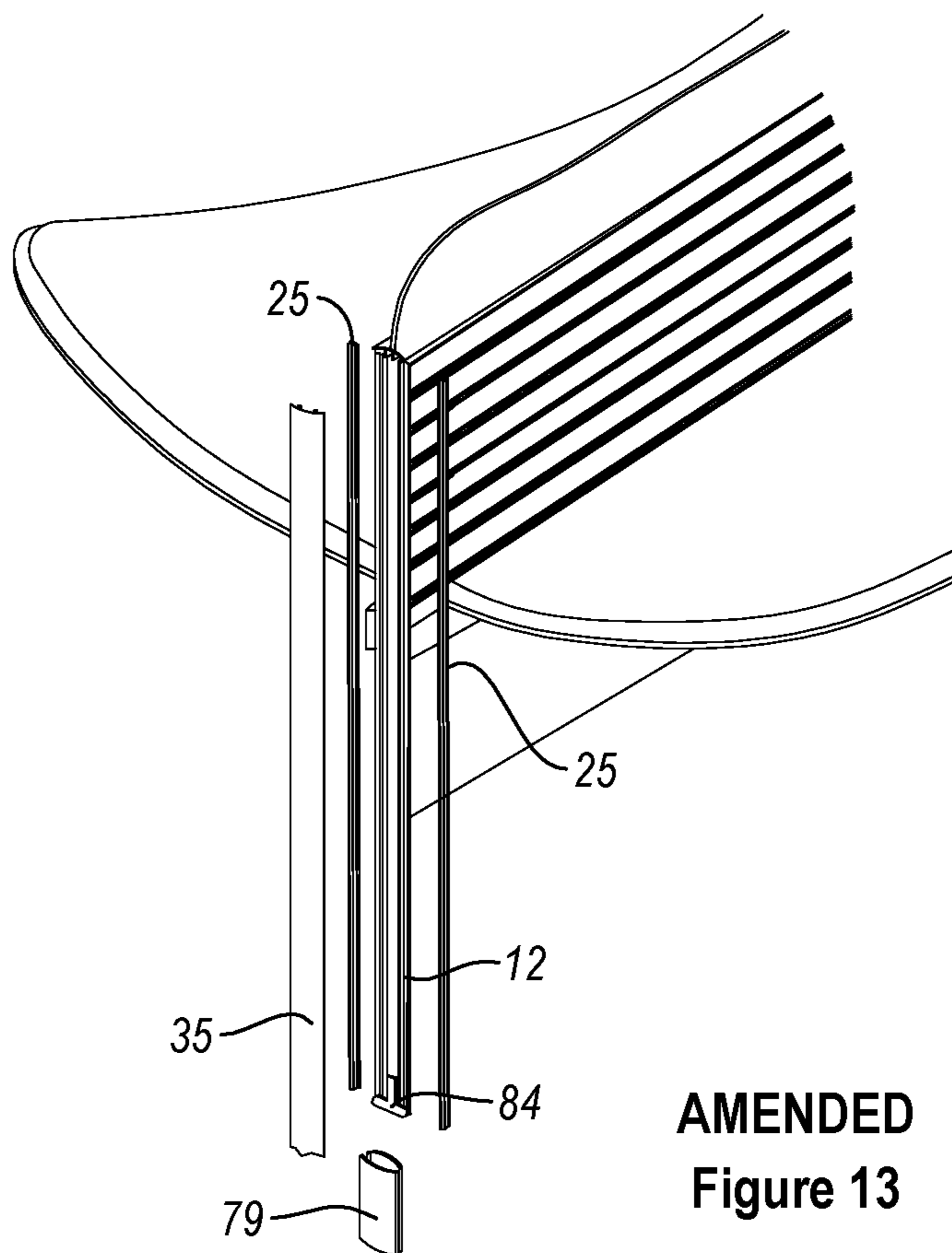

Figure 12



AMENDED
Figure 13

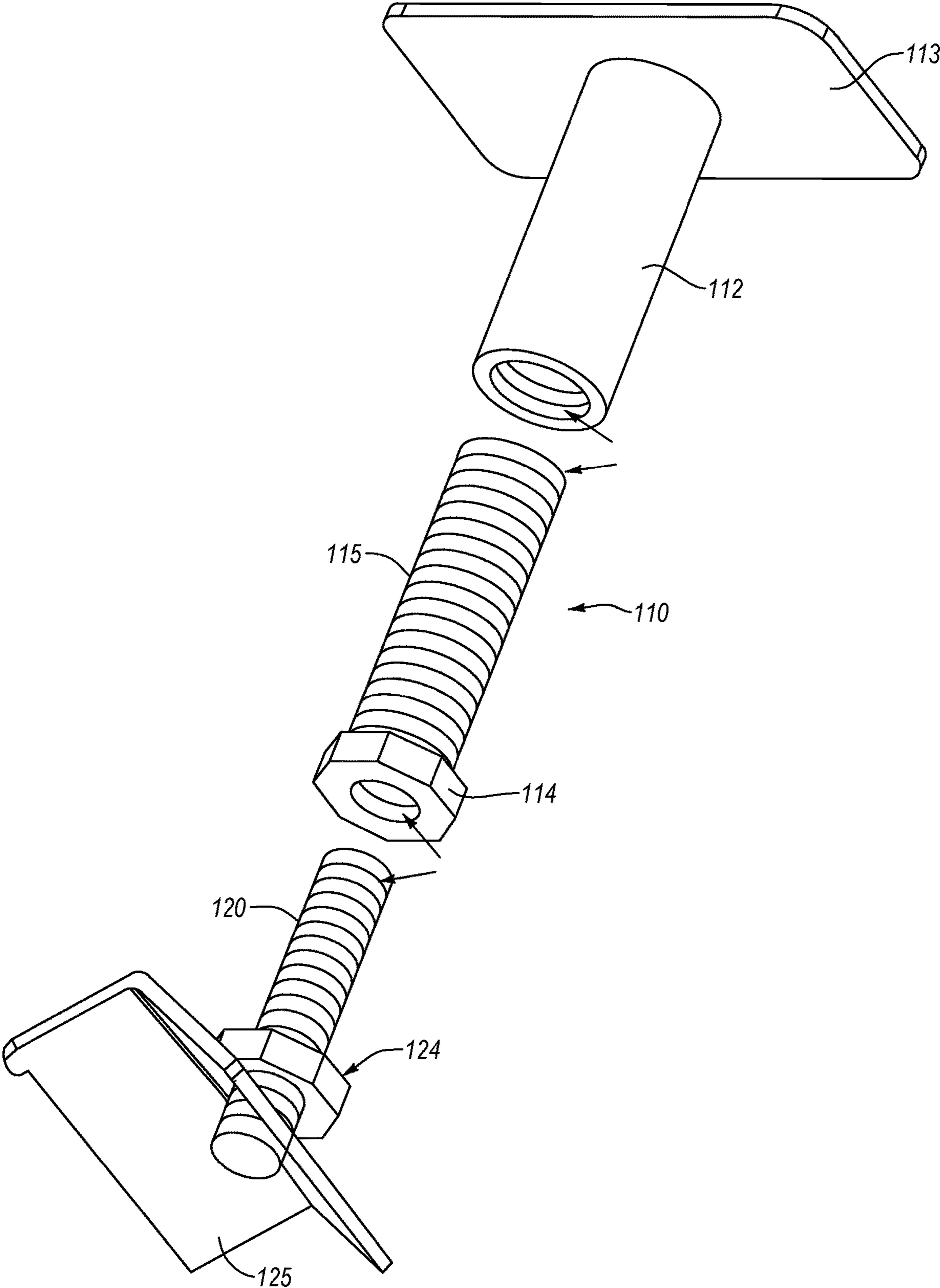
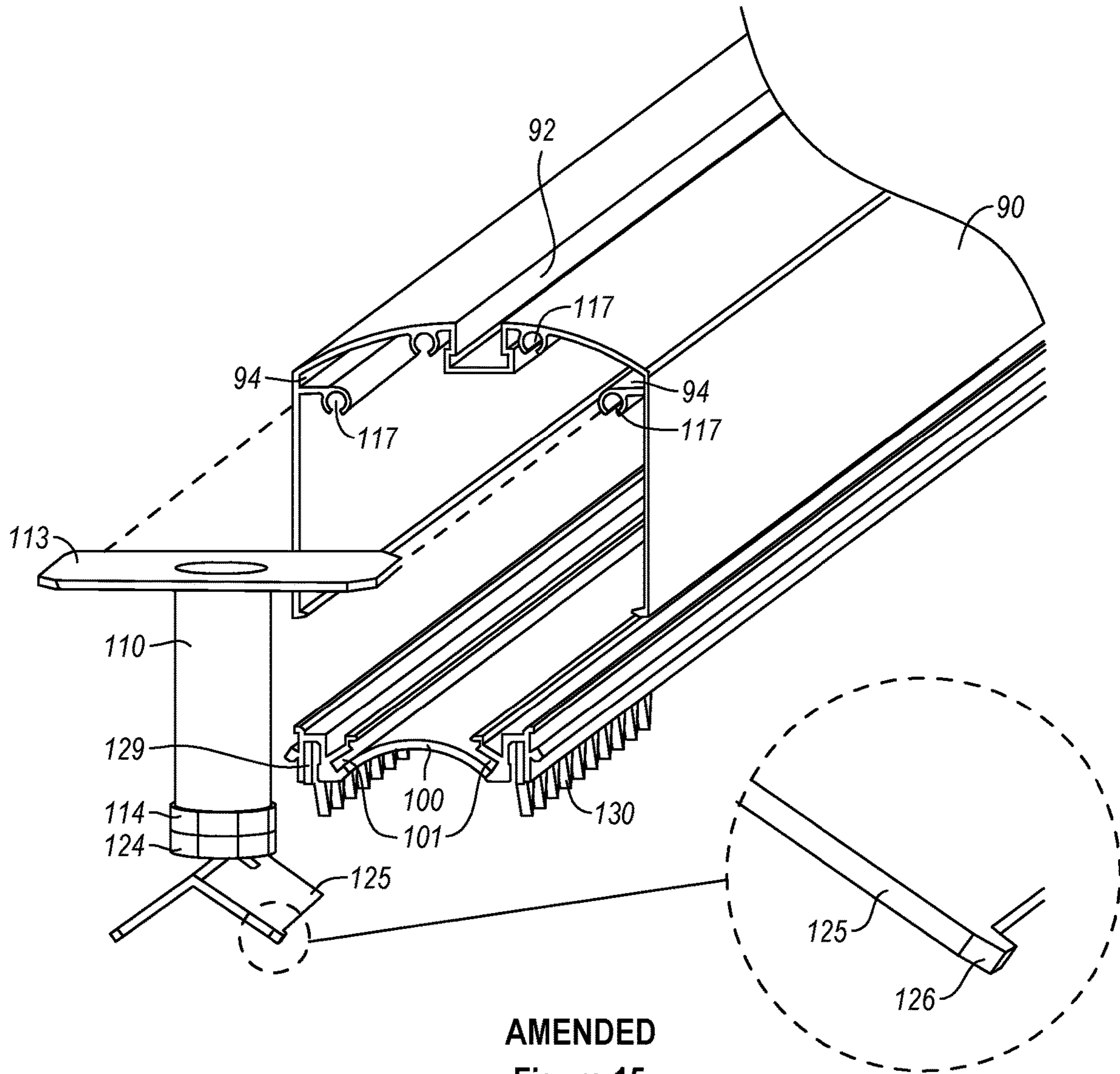
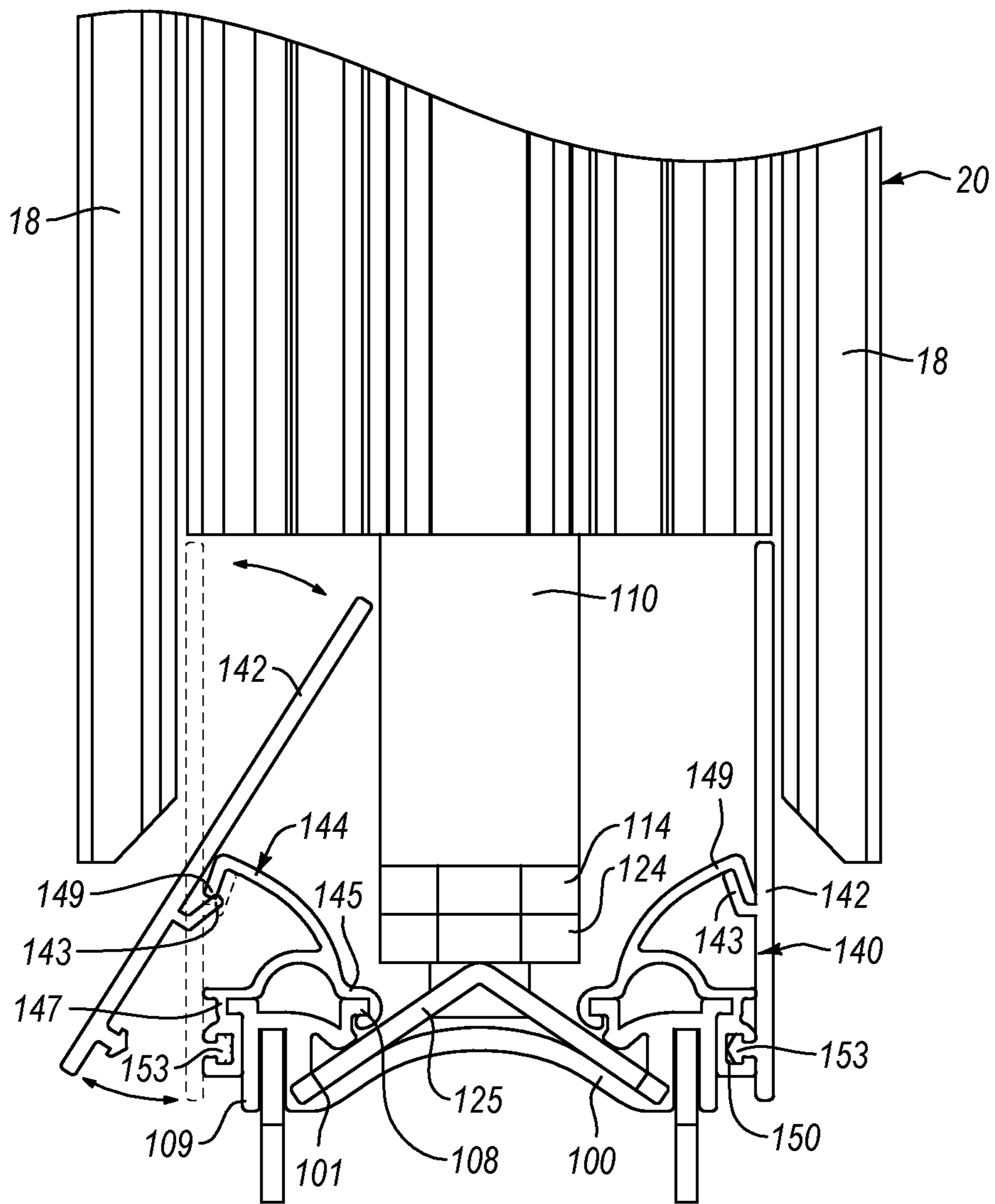

Figure 14



AMENDED
Figure 15



AMENDED
Figure 16

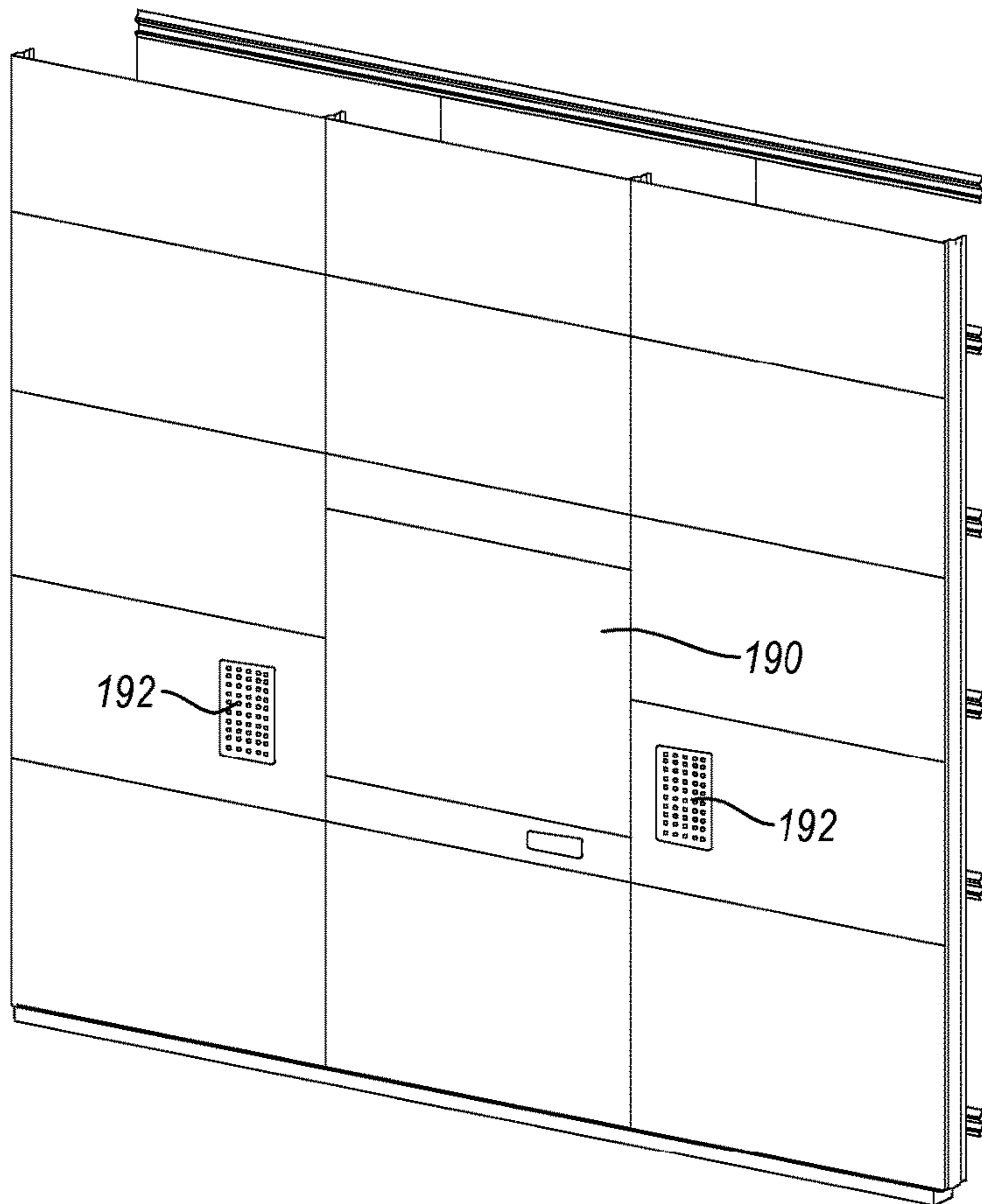

AMENDED
Figure 17

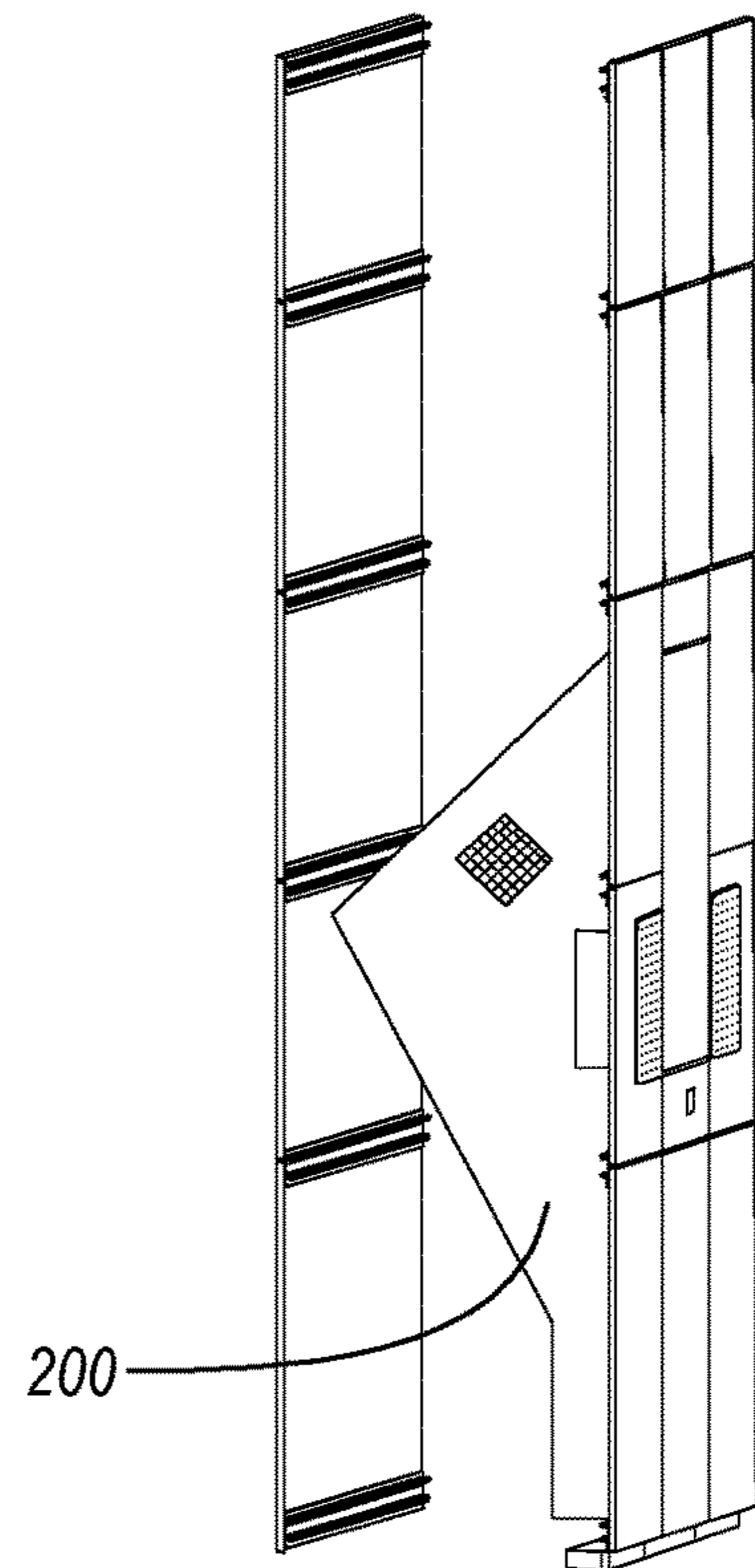

AMENDED
Figure 18

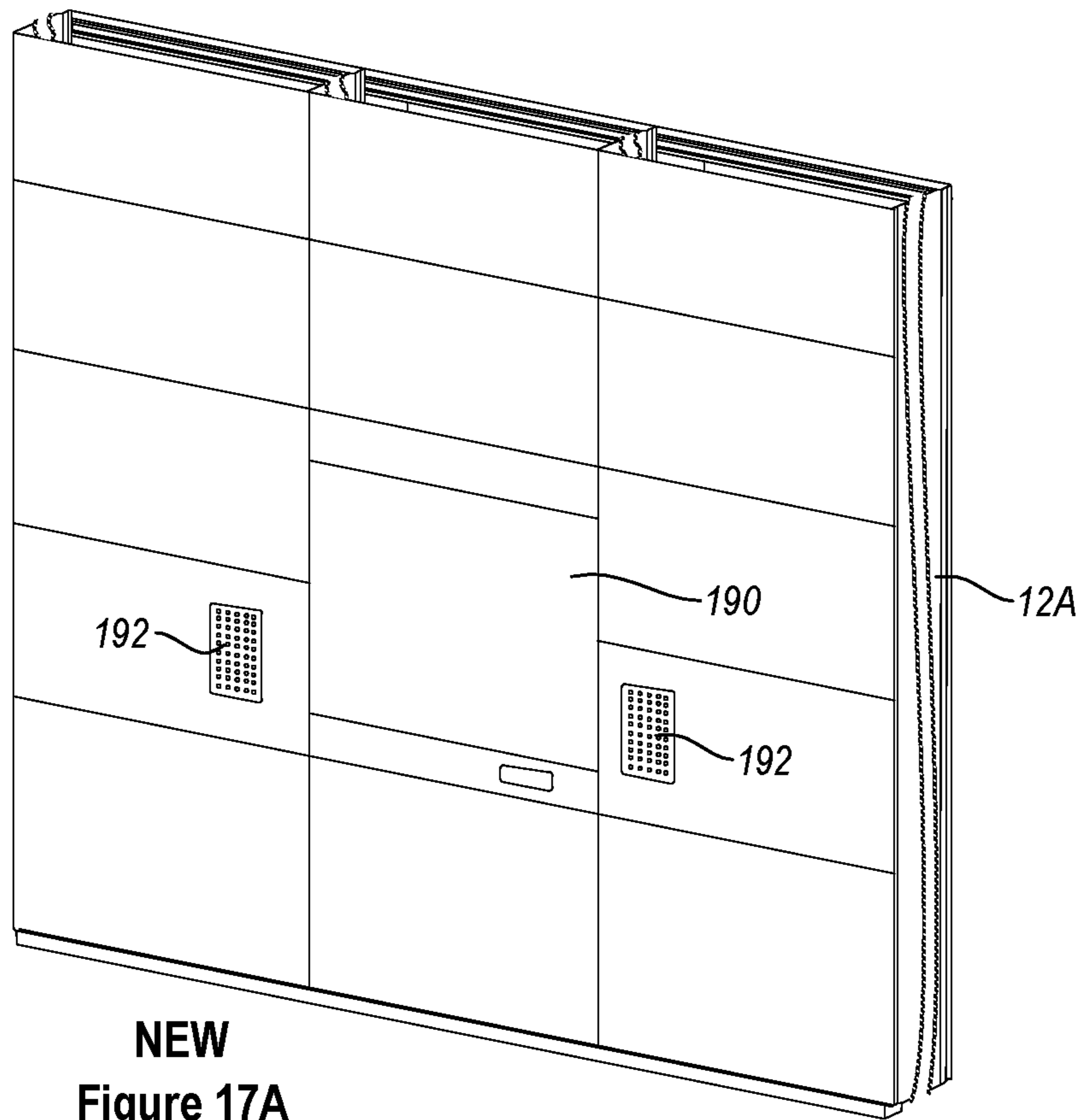

NEW
Figure 17A

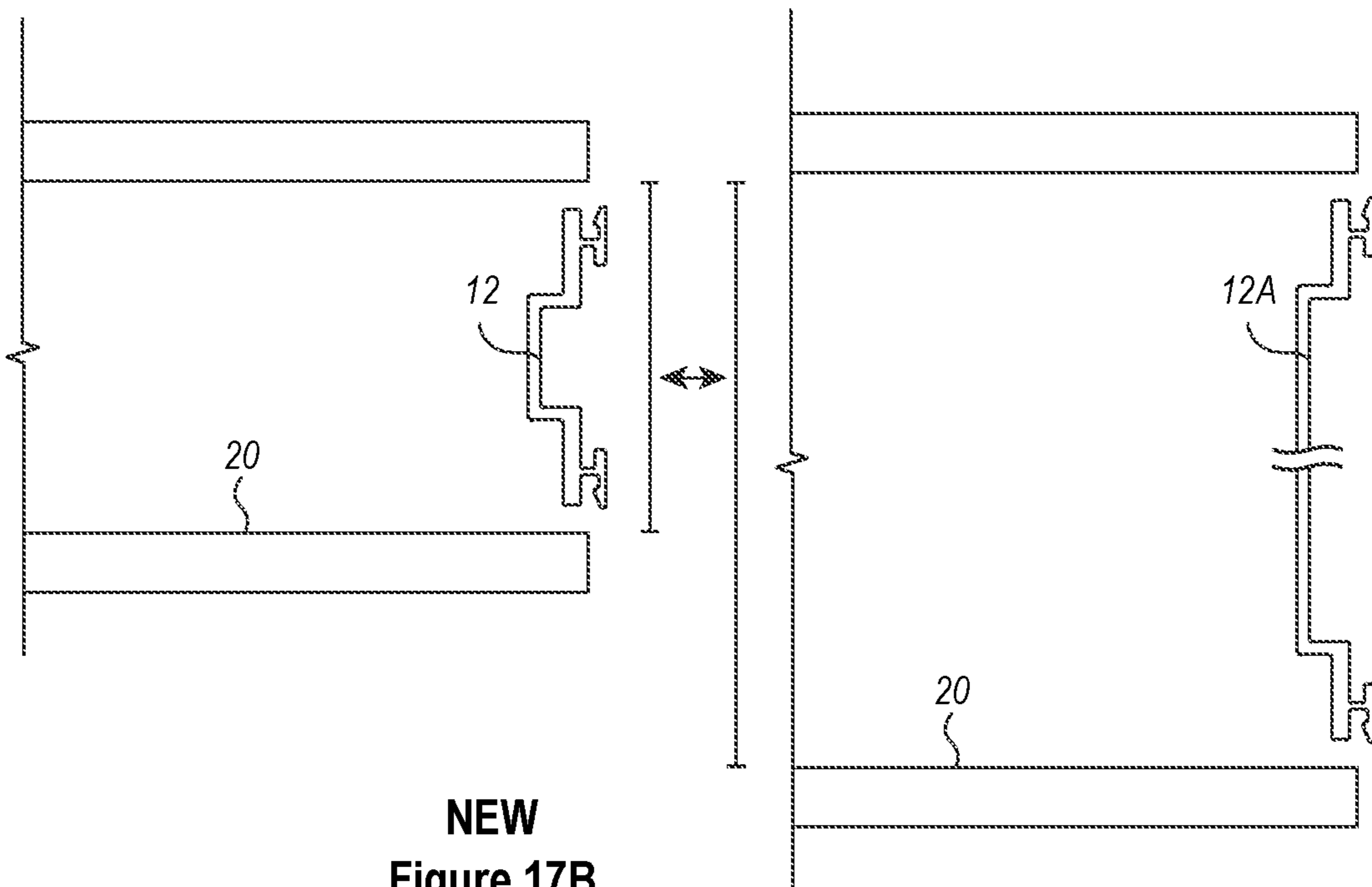

NEW
Figure 17B

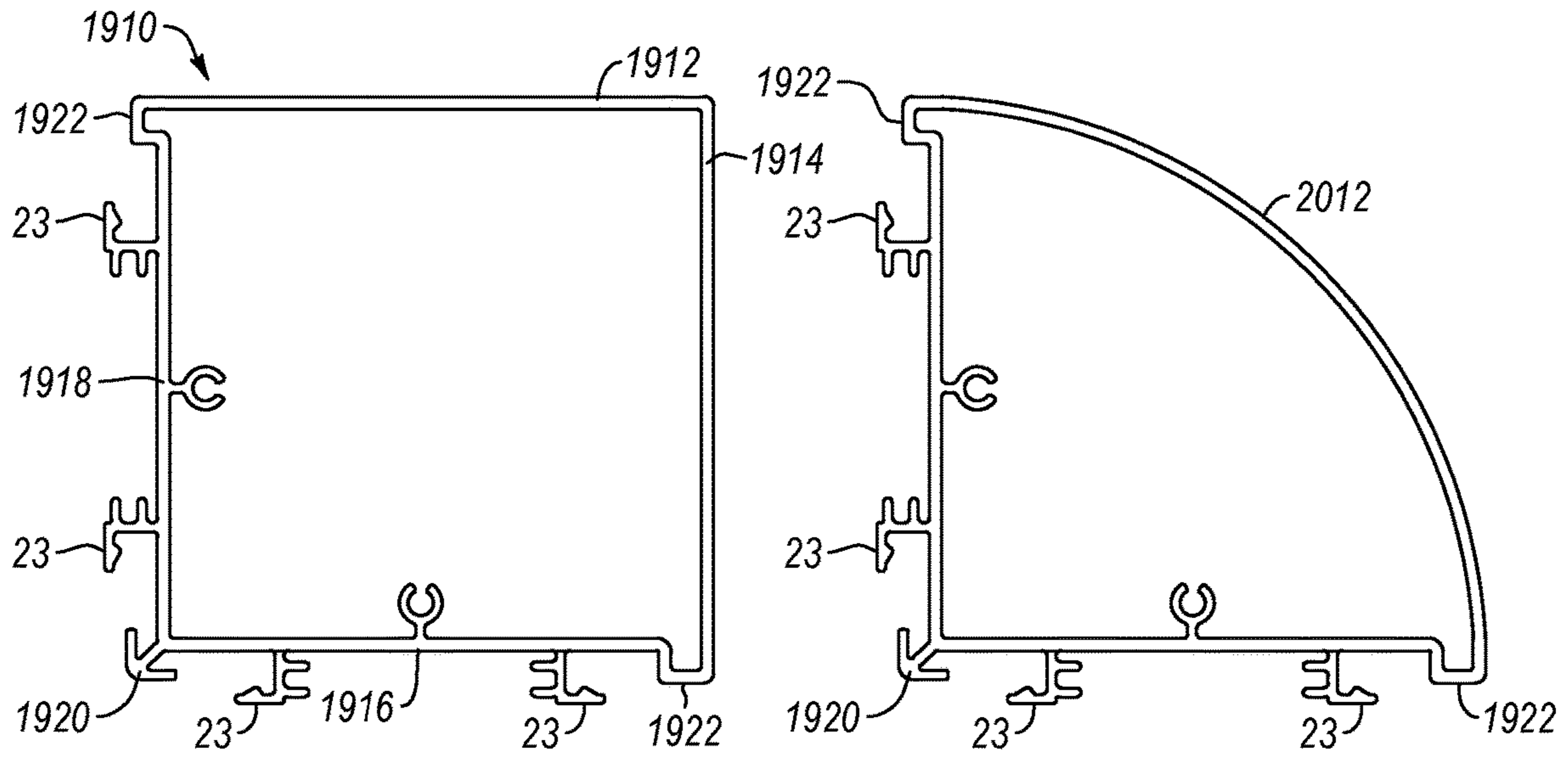

Figure 19

Figure 20

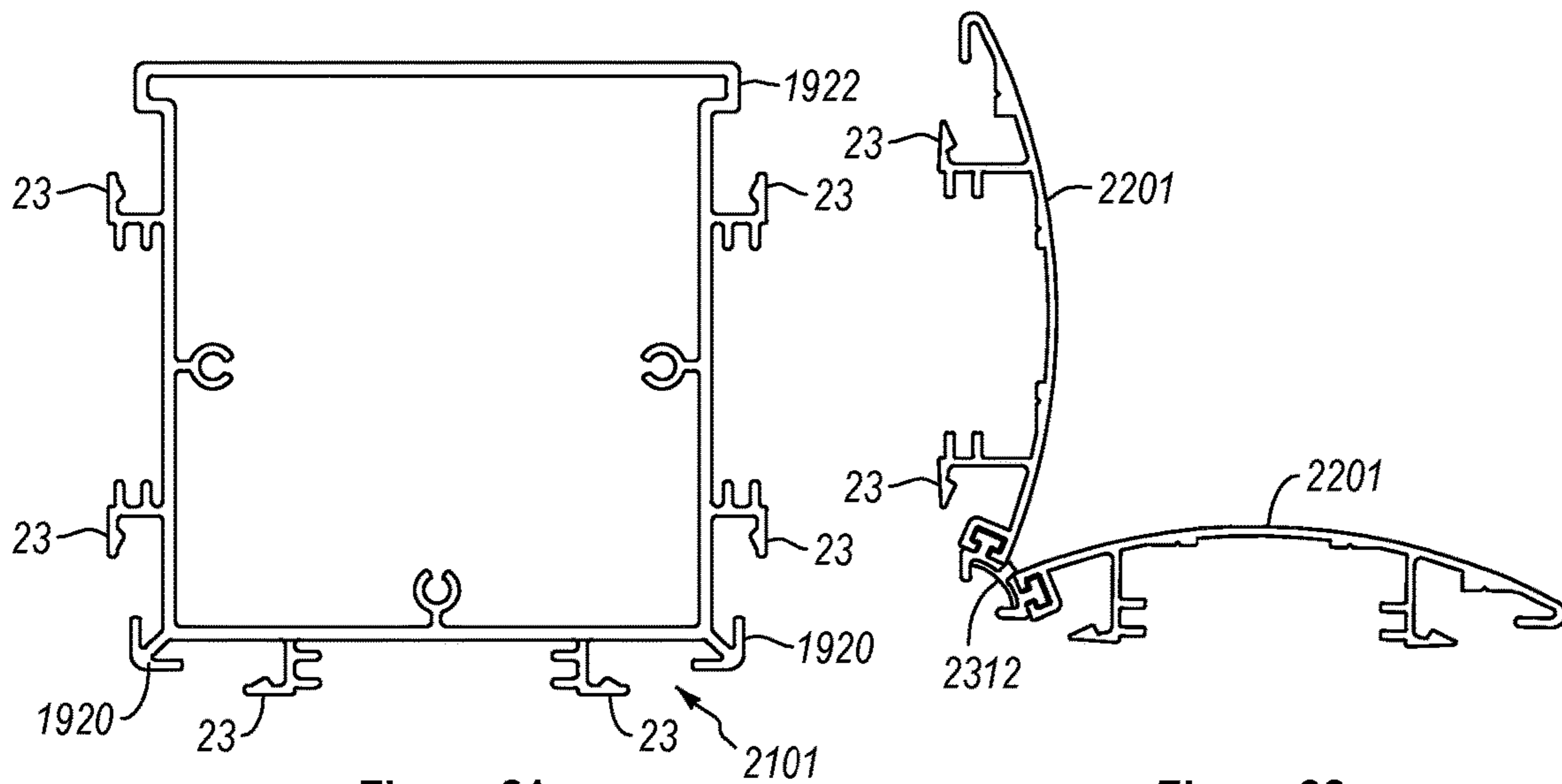

Figure 21

Figure 22

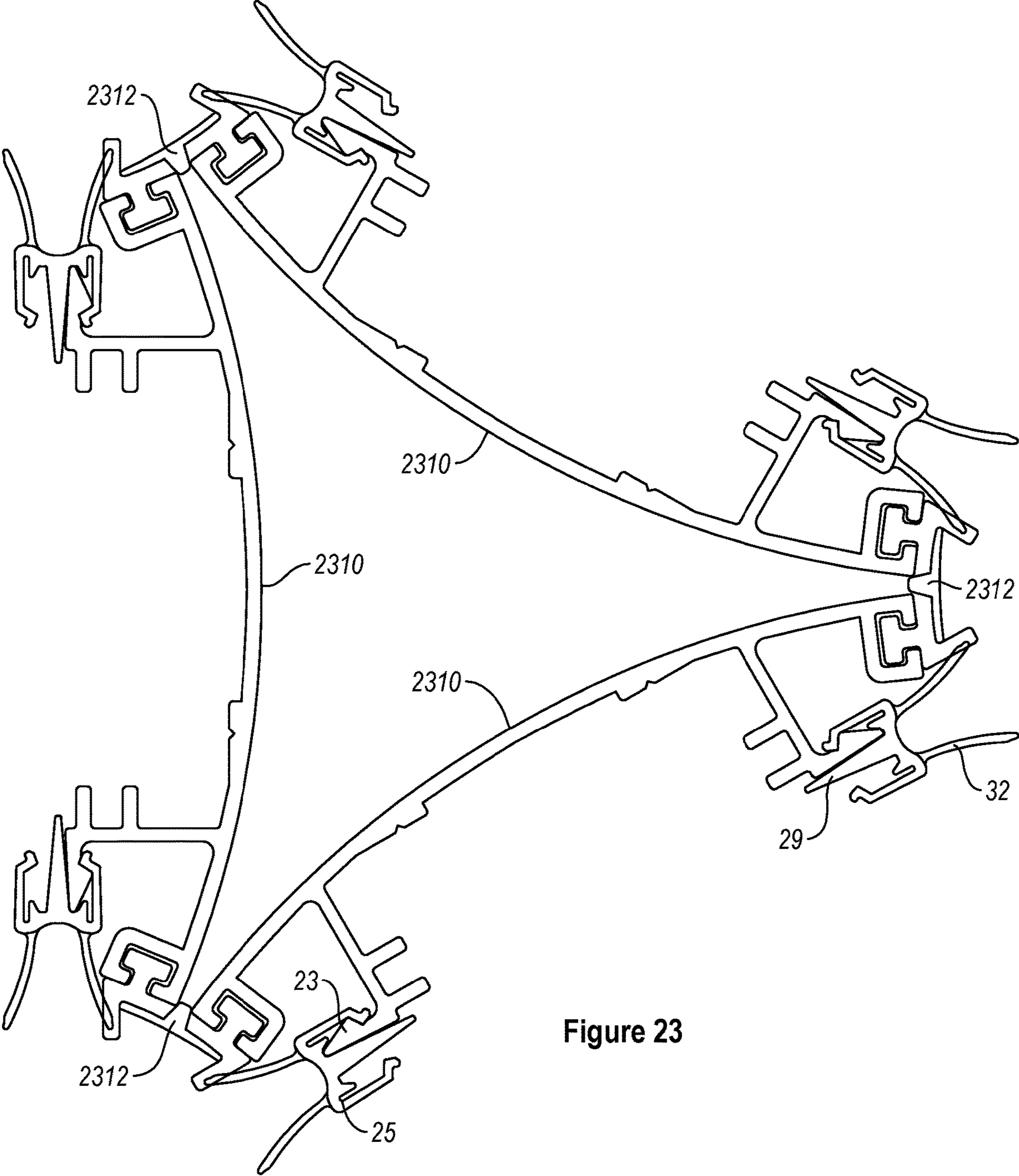
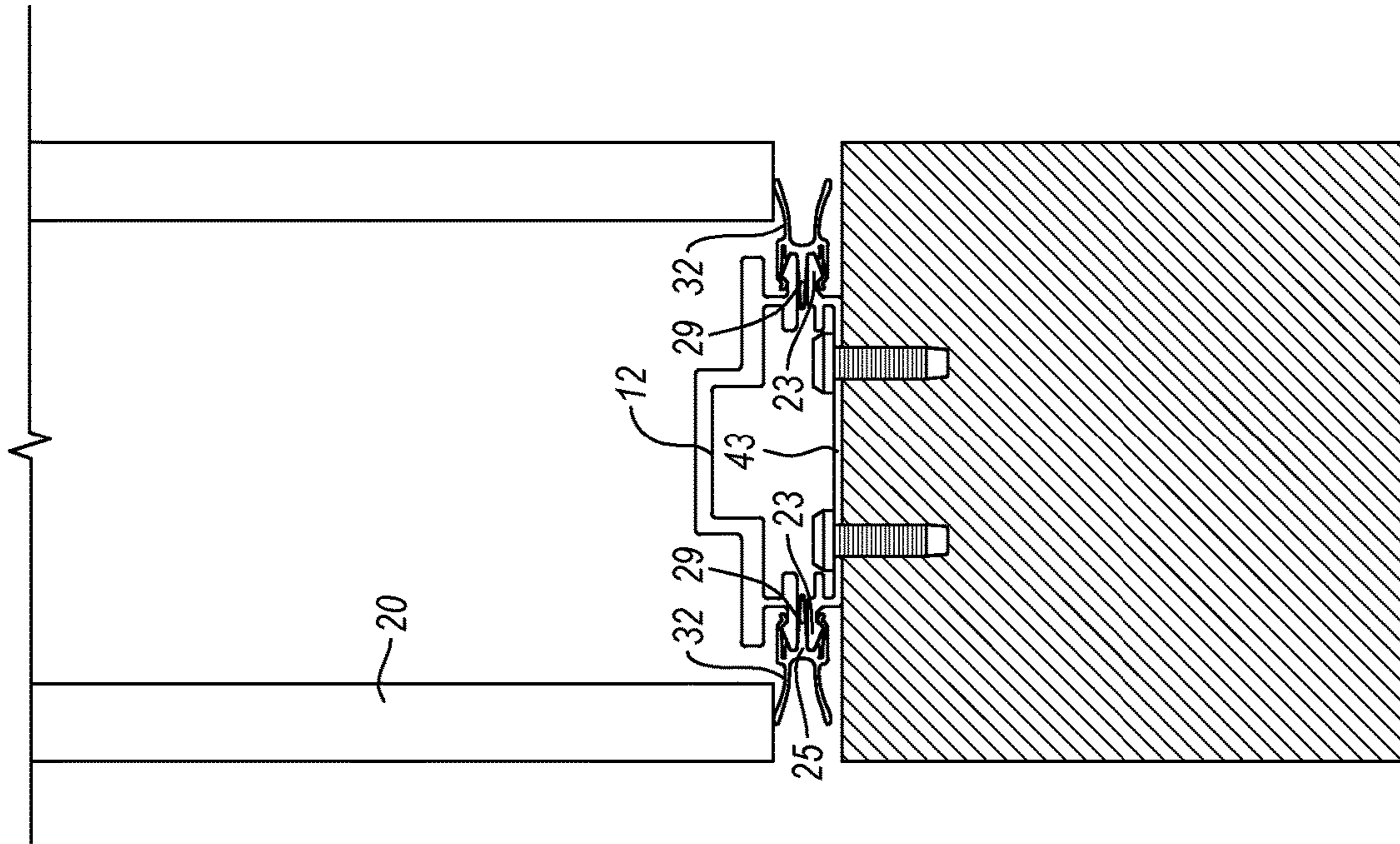

Figure 23



AMENDED
Figure 25

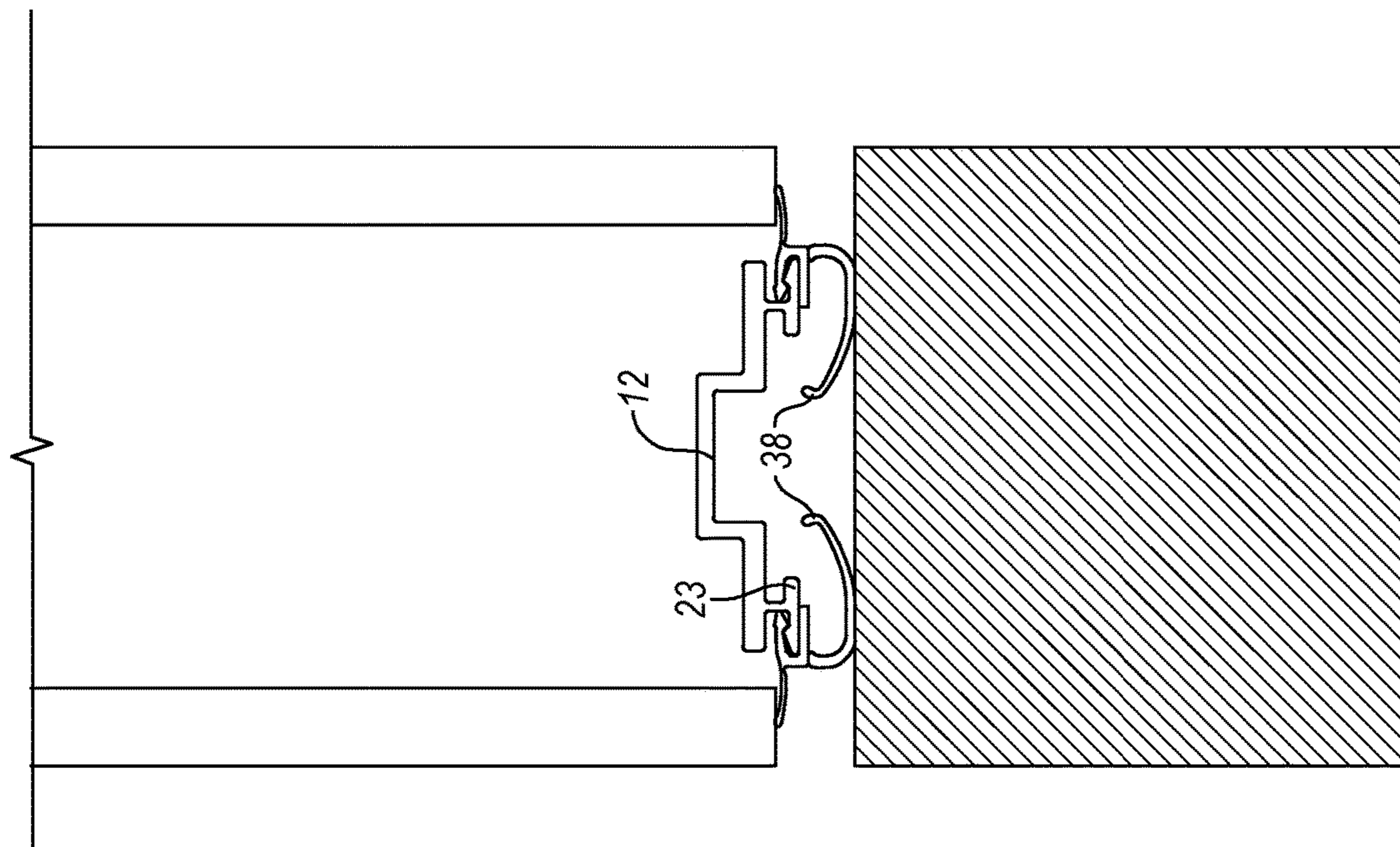
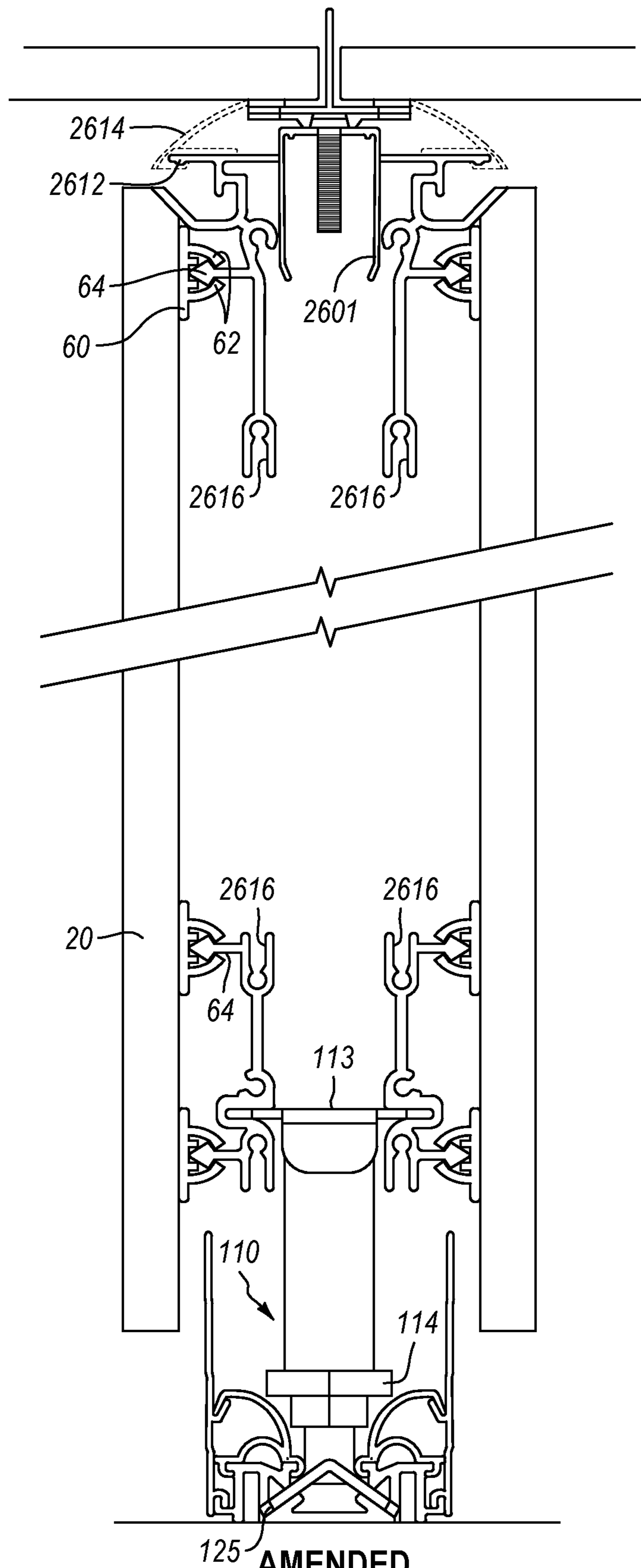

Figure 24



125 AMENDED
Figure 26

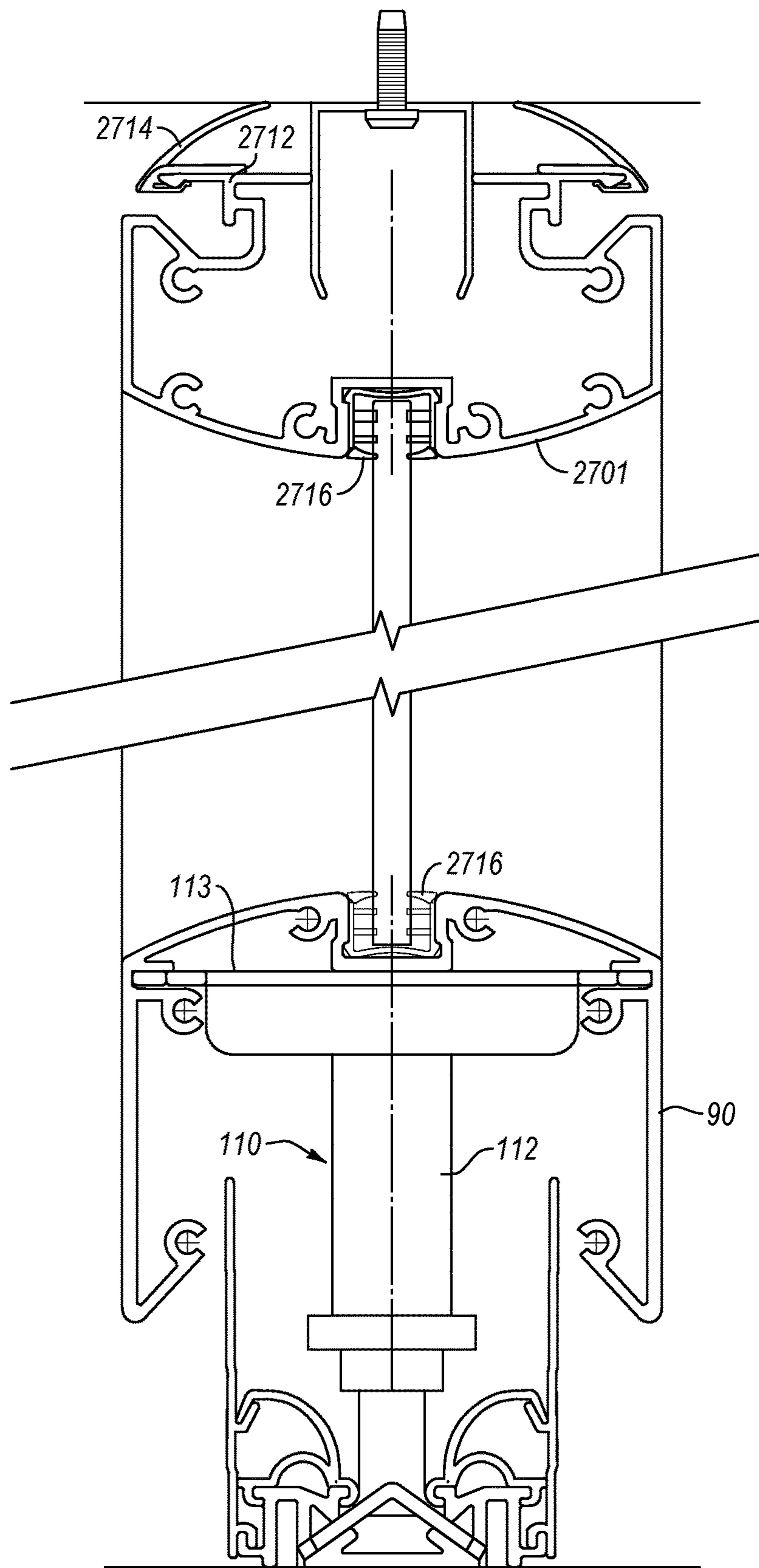
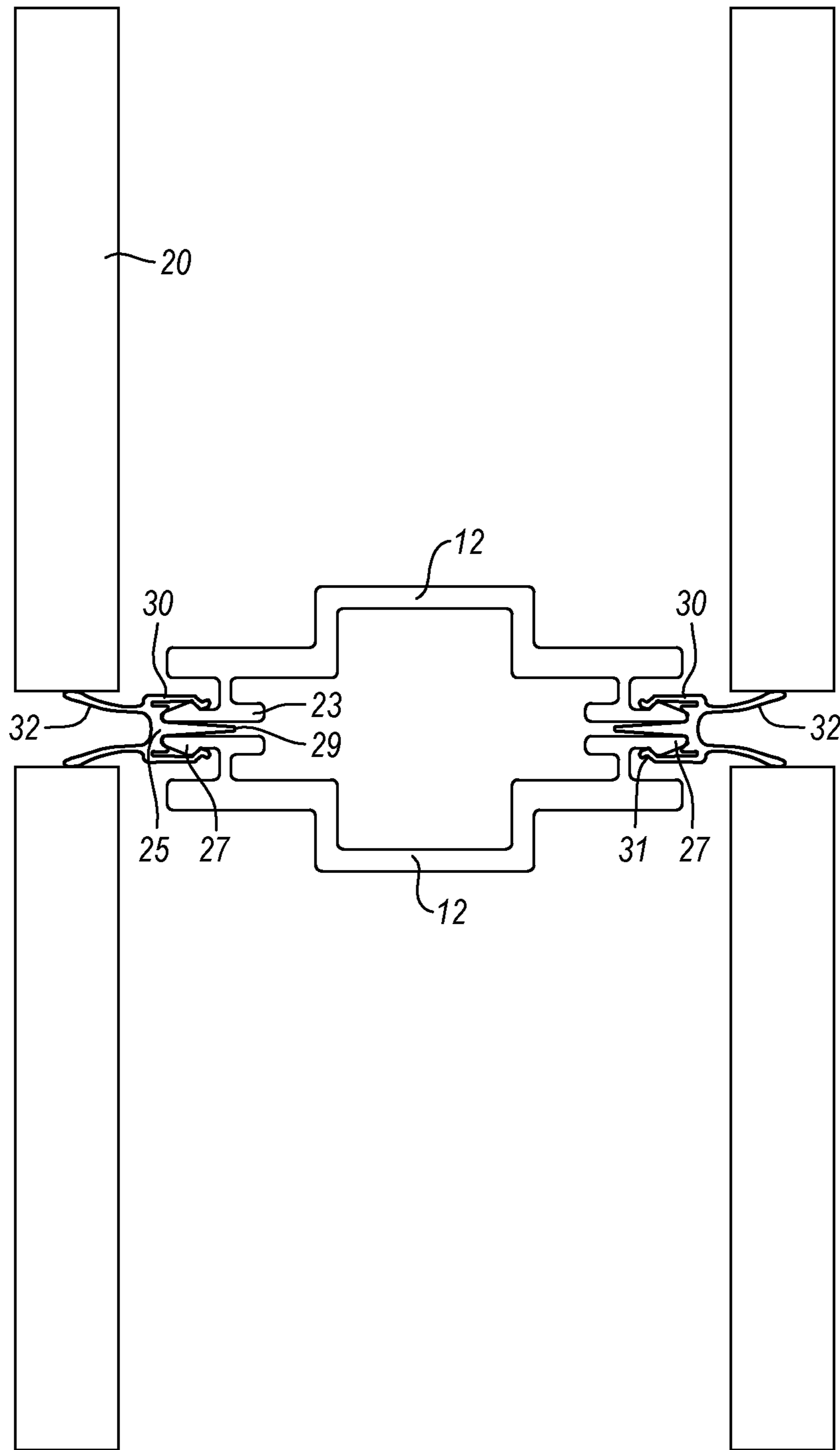

Figure 27



AMENDED
Figure 28

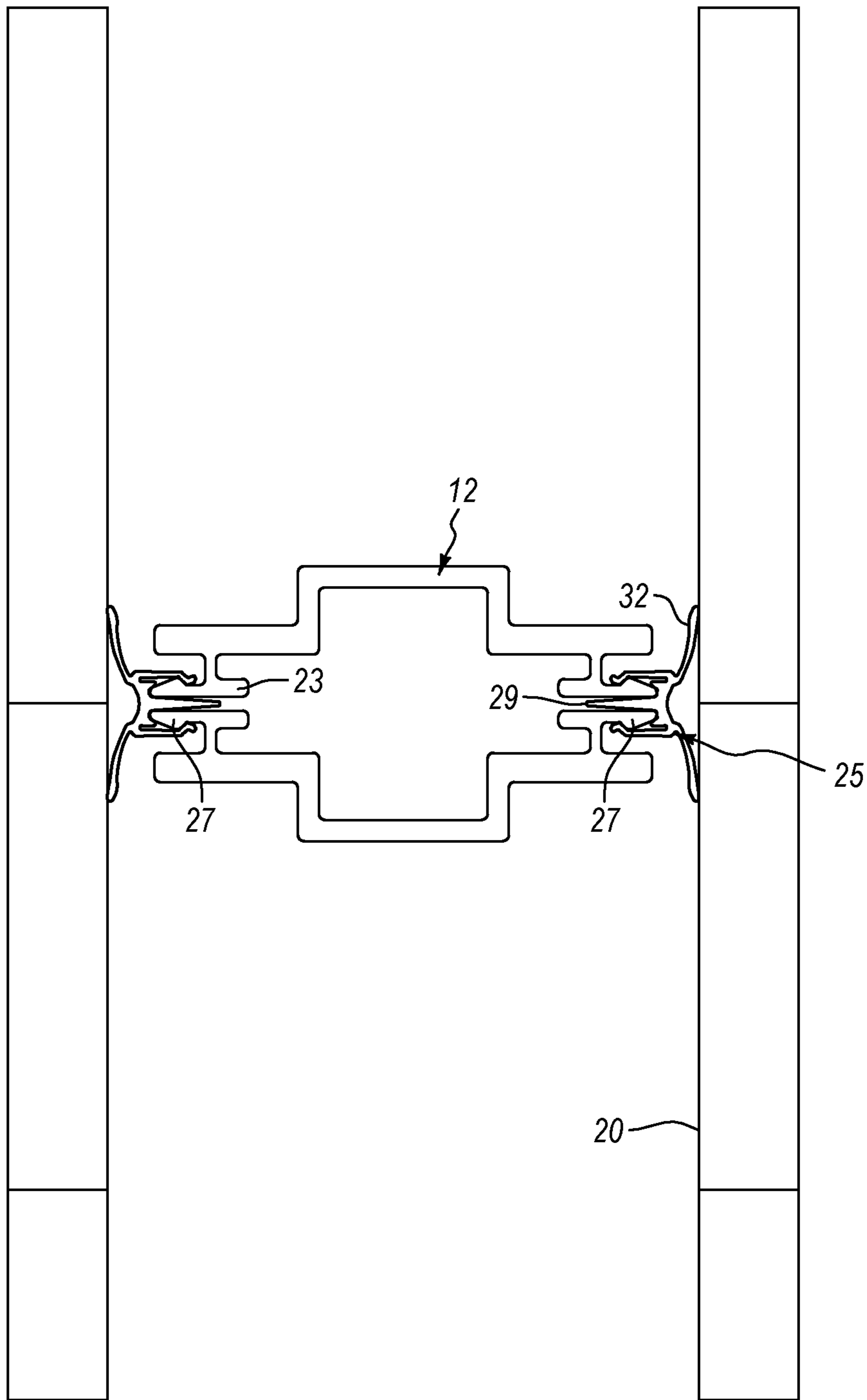

Figure 29

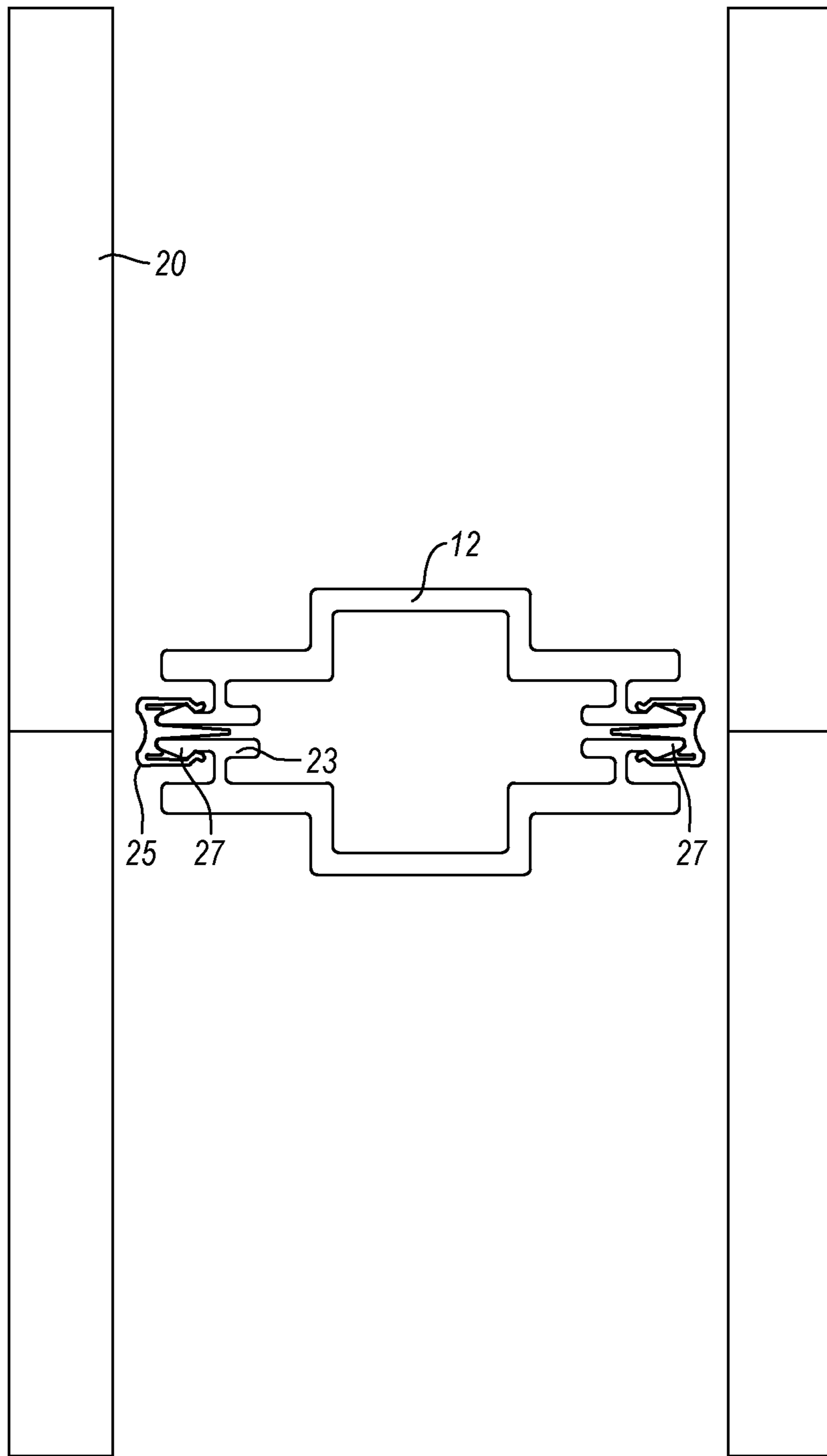

Figure 30

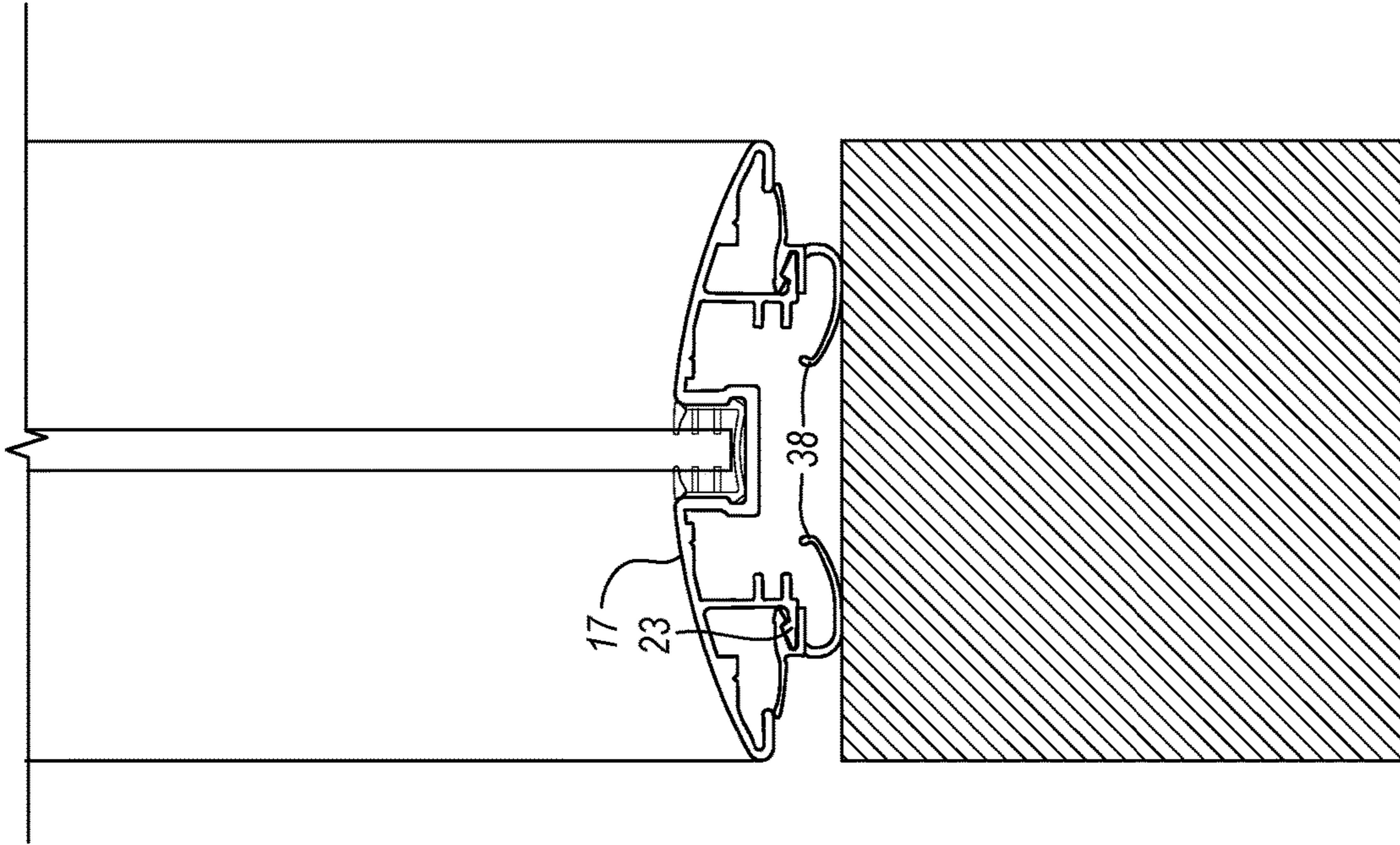
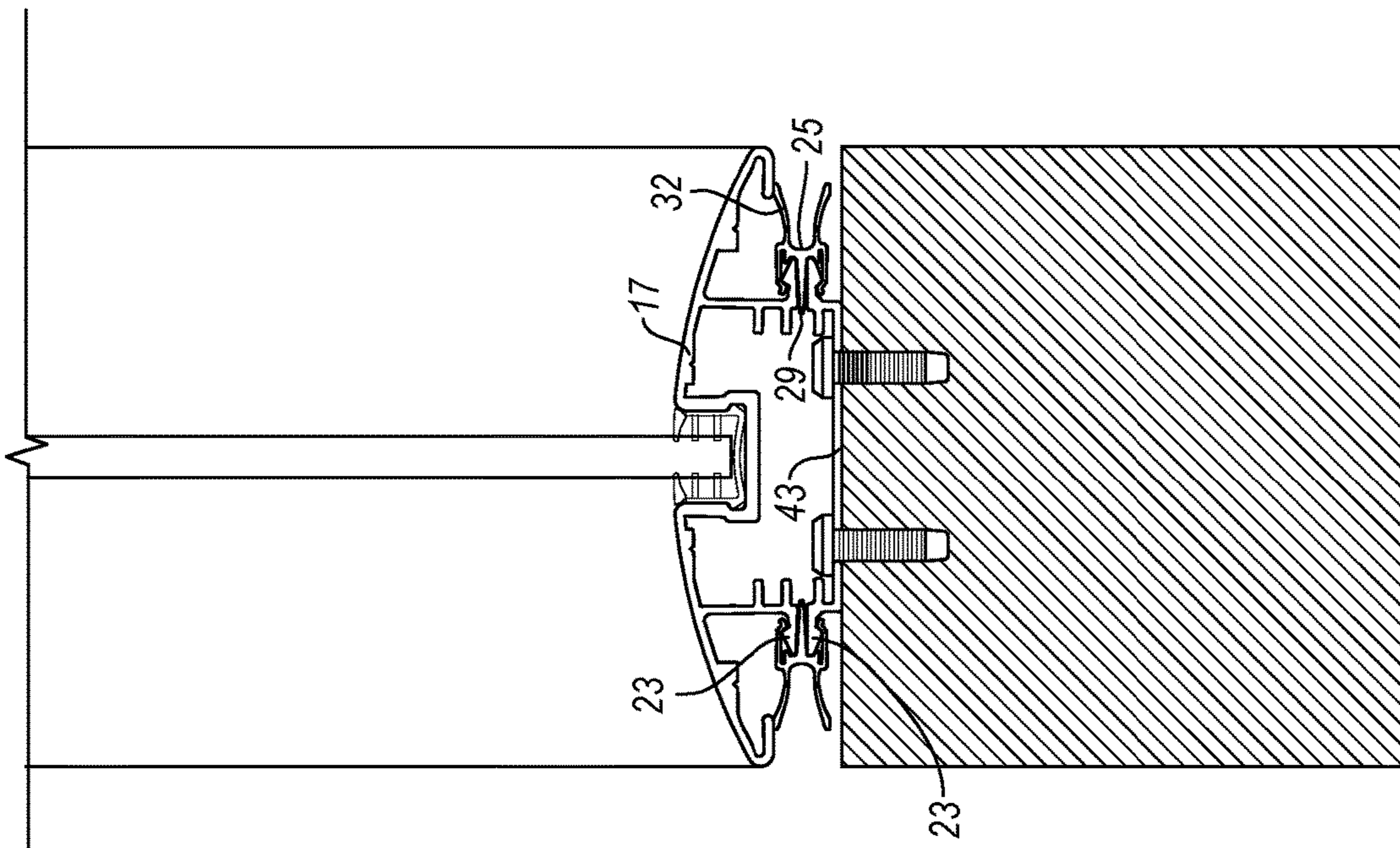

Figure 32



AMENDED
Figure 31

INTEGRATED RECONFIGURABLE WALL SYSTEM

Matter enclosed in heavy brackets [] appears in the original patent but forms no part of this reissue specification; matter printed in italics indicates the additions made by reissue; a claim printed with strikethrough indicates that the claim was canceled, disclaimed, or held invalid by a prior post-patent action or proceeding.

CROSS-REFERENCE TO RELATED APPLICATIONS

[The present invention] *Notice: More than one reissue application has been filed for the reissue of U.S. Pat. No. 8,024,901. The reissue applications are: the present application, Reissue application Ser. No. 14/681,874 (now RE46,929), Reissue application Ser. No. 14/305,819 (now RE47,132), and Reissue application Ser. No. 15/074,383 (now RE47,693). Reissue application Ser. No. 14/681,874 was filed on Apr. 8, 2015 and is a reissue divisional of Reissue application Ser. No. 14/032,931. Reissue application Ser. No. 14/305,819 was filed on Jun. 16, 2014 and is a continuation reissue of Reissue application Ser. No. 14/032,931. Reissue application Ser. No. 15/074,383 was filed on Mar. 18, 2016 and is a continuation reissue of Reissue application Ser. No. 14/032,931. This application is an application for reissue of U.S. Pat. No. 8,024,901, which claims the benefit of the filing date of U.S. Provisional Patent Application Ser. No. 60/601,985, entitled "INTEGRATED RECONFIGURABLE WALL SYSTEM", filed Aug. 17, 2004.*

FIELD OF THE INVENTION

The present invention relates to a wall moveable system, and more particularly to a reconfigurable moveable wall system comprising reconfigurable components and design elements.

BACKGROUND OF THE INVENTION

Wall systems, or dividers as they are sometimes called, are used most commonly in an office environment to separate work areas and to give people privacy where permanent walls are lacking. It is beneficial to have a wall system that is easily movable and easily reconfigured given the ever changing needs and requirements in these environments. Another important aspect in an office is to maximize available space. Aesthetics are also important, including the ability to provide the aesthetic element independently of underlying structural componentry.

Previous wall systems have lacked some or all of these attributes. Some are difficult to reconfigure or to move without significant amounts of labour and dislocation. Most systems lack the flexibility to quickly change the height of a wall, or to use or substitute different types of panels, or replace a module in the middle of a wall without taking apart the entire wall. There also is a need to be able to use the wall system against an existing wall as a curtain wall for an integrated look and to provide the design flexibility needed in those spaces bordered by permanent walls.

SUMMARY OF THE INVENTION

In a preferred embodiment, the present wall system comprises at least one module, where each module includes a

frame and a plurality of tiles mounted to the frame by means of a tile clip system. Clips are attached to the rear surface of each tile and the tile is then pressed into place, aligning the clips with a capture detail on the horizontal frame stringers. Tiles can span adjacent frames where required. Horizontal frame stringers may include a cantilever channel detail where desired to allow objects to be hung along the width. A single frame comprised of two verticals frame members and a plurality of horizontal stringers mounted to an existing wall by connecting the horizontal members to brackets attached to the existing wall allows tiles to be mounted as a curtain wall on the existing wall. Two frames may be supported back to back within a framework for modules used to divide adjacent work spaces. A spline is attachable to the top of the frame to extend the frame and allow for additional tiles to be added on to increase a module's height if so desired. The spline is also used to connect a different style of frame above the existing frame if so desired. For example, this allows a framed glass module to be attached above a framed wood substrate module. Two adjacent modules are connected using a removable zipper interface. The zipper contains two flexible gasket components. Where tiles will span adjacent frames or meet one another without a gap, the gaskets bend back behind the tiles. Where tiles do not span adjacent frames and a gap is wanted, the gaskets point outward from the frame, between the tiles. At the edge of a module where no other module is to be connected, a starter strip may be placed, wherein the starter strip includes an integral flexible gasket which conforms to the shape of the surrounding environment while providing both light and sound baffling. The cantilever channel between tiles allows for various accessories or mill work to be supported from the outside of the module at convenient locations and to be adjusted as needed.

The present wall system also includes a glass wall module, where each module includes a frame and a plurality of glass tiles mounted within the frame. The glass may be center mounted, front mounted or rear mounted. A channel within each end frame extrusion holds a full length gasket extrusion or notch. The glass is retained within the gasket extrusion, around the full perimeter of the glass tile. Extra horizontal or vertical extrusions are attached within the frame to further divide the module into smaller areas.

The present wall system also includes levelers. Levelers include upper, middle and lower sections. The upper section includes a hollow cylinder which is threaded along the interior, and a flat upper plated perpendicular to the leveler. The middle section is a hollow cylinder where the interior and exterior surfaces are threaded in opposite directions, with a fixed nut at one end of the middle section for adjustment. The lower section includes a solid cylinder threaded to correspond with the middle section, a fixed lower nut and an inverted V-shaped lower plate. The leveler is used by having the flat plate in the upper section engage a continuous channel in an the lowermost extrusion of a module's frame, and the lower plate engaging a continuous universal foot, located beneath each module. The V-shape of the lower plate distributes the weight of the wall in the direction of the connection channels of continuous universal foot. A leveler can be placed at any location along the width of the module, allowing for a plurality of levelers to be used if needed. Along the base of the universal foot is a plurality of grippers, which can be adapted for either carpet or hard flooring surfaces. The attachment of the leveler to the module is secure and without extra fastener requirement of any sort. Sliding the leveler plates into the extrusion chan-

3

nels, followed by the attachment of subsequent vertical members, secures the levelers in place.

A base trim is provided which, in one embodiment, can be removably secured to the universal foot to provide access to the levelers when needed but which otherwise provides a finished look to the modules. The base trim can be modular, or span multiple frames.

Wall modules can be adapted to include integrated rear projection video systems or digital whiteboards. Front projection screens or whiteboards can be mounted within the frame confines, or spanning adjacent frames.

The present wall system provides for true curved walls. Curved wall frames are comprised of straight vertical extrusions and stretch formed horizontal extrusions which are curved to the required radius. Glass or other substrate tiles are curved to match the radius of the frame and mounted in the same manner as planar wall modules.

The present wall system can incorporate universal slat wall constructions which would accept all standard slat wall accessories. The slat wall component is a horizontal structural extrusion, interlocking above and below the cantilever channel horizontal member or other slat wall extrusions.

The present wall system can also support desktops and work surfaces using support brackets in the cantilever channel.

The present wall system also integrates completely with a related furniture panel system. A furniture panel system is comprised of a frame and plurality of tiles attached to the frame. The furniture panel system is designed to serve as cubicle type dividers or desk type units, rather than full height walls. The integration to the furniture panel system is seamless, as the zipper connection detail, tile clip capture detail and cantilever detail are identical to the wall system connection details. All components used in or on the wall system can also be used in or on the furniture panel system.

According to the present invention then, there is provided a movable reconfigurable wall system comprising: at least one module having a front and rear surface, said at least one module having: vertical end frames disposed at least at its side edges, each said vertical end frame having a vertically extending flange directed toward said front surface and a vertically extending flange directed toward said rear surface; a plurality of horizontal stringers affixed between said pair of vertical end frames; and an aesthetic surface affixed to said stringers; and a removable connecting strip, said connecting strip adapted to affix about one of said two flanges on one of said vertical end frames and join said one of said two flanges to a corresponding flange on one of a second module, a wall bracket, a finishing trim or a connection post.

BRIEF DESCRIPTION OF THE DRAWINGS

Preferred embodiments of the applicant's integrated reconfigurable wall system will now be described in greater detail and will be better understood when read in conjunction with the following drawings in which:

FIG. 1 is an exploded perspective view of a module representative of the present tile clad wall system;

FIG. 2 is a perspective view of a wall system including two adjacent modules, one tile clad and one glass wall;

FIG. 3 is an enlarged view of a portion of the wall system of FIG. 3 showing the connection between adjacent modules;

FIG. 4 is an exploded view of FIG. 3;

FIG. 5 is a perspective view of a frame member including a finishing trim;

4

FIG. 6 is a perspective view of a frame member including a wall starter trim where a module meets an existing wall;

FIG. 7 is a perspective view of a height extension to an existing module;

FIG. 8 is a perspective view of a portion of a wall module showing the orientation of horizontal members with integrated cantilever channel;

FIG. 9 is an enlarged view of a portion of FIG. 8 showing cantilever bracket details and tile clip connection details;

FIG. 10 is a perspective view of a wall panel incorporating slat wall construction;

FIG. 11 is a side elevational view of the slat wall construction of FIG. 10;

FIG. 12 is a perspective view of the related panel furniture system utilizing the same connectors and slat wall extrusion to support a work surface;

FIG. 13 is a perspective, partially exploded view showing the assembly of a leg used to support the panel furniture system, utilizing the same connection zipper as the wall components of FIG. 12;

FIG. 14 is a perspective, exploded view of a leveller for use with the present wall system;

FIG. 15 is a perspective view of one embodiment of a leveller mounting system as it slides into the channel of a lower glass wall extrusion and universal foot extrusion;

FIG. 16 is a side elevational view of the base trim connection to the leveller assembly;

FIG. 17 is a perspective, schematic view of the present wall system including integrated media panels and storage areas;

FIG. 17A is a perspective, schematic view of the wall system shown in FIG. 17, albeit showing vertical end frames with extended depth;

FIG. 17B is a schematic, comparative top end view of different vertical end frames with varying depth;

FIG. 18 is a perspective, schematic view of the present wall system incorporating an integrated media center;

FIG. 19 is a plan view of a two-way rectilinear connector for the present wall system;

FIG. 20 is a plan view of an alternative (radial) two-way connector for the present wall system;

FIG. 21 is a plan view of a three-way connector for the present wall system;

FIG. 22 is a plan view of a variance of a 90 degree connector for the present wall system;

FIG. 23 is a plan view of a 120 degree connector for three merging walls according to the present wall system;

FIG. 24 is a plan view of an end vertical and gasket for abutting existing walls with the present wall system;

FIG. 25 is a plan view of a connector for connecting to existing walls according to the present wall system;

FIG. 26 is a side elevational view of a floor leveller and ceiling connector for a solid (tile clad) wall;

FIG. 27 is a side elevational view of a floor leveller and ceiling connector for a glass wall;

FIG. 28 is a plan view of two wall panels having a gap between adjoining panels;

FIG. 29 is a plan view of two wall panels directly abutting each other and being sealed with a zipper;

FIG. 30 is a plan view of two wall panels directly abutting each other and having a zipper with no fins;

FIG. 31 is a plan view of an end vertical and gasket for abutting existing walls with the present glass wall system; and

FIG. 32 is a plan view of a connector for connecting to existing walls according to the present glass wall system.

DETAILED DESCRIPTION OF THE PREFERRED EMBODIMENTS

With reference to FIG. 1, the present invention is directed towards a wall system 10 made up of one or more modules 20. Each module comprises a pair of vertical end frames 12 that will be spaced apart by the desired width of each module. Modules 20 may be clad with tiles 18 and can be one or two sided with a finished wall surface on both sides or a finished wall surface on one side only. Tiles 18 can be made of wood, plastic, metal fabric glass or other material, and end frames 12 may be interconnected by a plurality of horizontal stringers 8 that will be described in greater detail below.

With reference to FIG. 2, the next adjacent module 20 can be identical to its neighbour, or, as shown in this figure, may consist of two vertical end frames 17 and one or more dividers 14 which can be, for example, glass or plastic if transparency is desired. End frames 17 used for such dividers are shaped as shown most clearly in FIG. 4 and include a notch 19 that receives and holds the divider's vertical edge.

Stringers 8 are horizontally spaced apart at intervals along the height of the module for strength and rigidity. To support objects, cantilever channel stringers 40, including a cantilever channel portion 41, are used, as shown in FIGS. 8 and 9. Stringers 8 that do not include channel portion 41 can be used anywhere structure is required but the channel portion is not required for supporting objects. For example, the lowest stringer 8a may not include cantilever channel portion 41. The stringers are connected to end frames 12 by fasteners, usually threaded screws, in a manner to be described below.

If the module will be visible from both sides, finishing tiles 18 can be connected to the stringers on both sides of module 20. It is not necessary that the tiles on one side of the wall be at all like the tiles on the other. They can be different materials or even aligned differently as shown in FIG. 1, in which the tiles on one side of the module are horizontally mounted and the tiles on the other side of the wall are vertically mounted for a different look. The tiles can also span adjacent modules, if required. *For example, FIG. 1A depicts finishing tiles 18 spanning adjacent modules 20.* If only one side of the module will be visible, which can be the case for example if the module is used as a curtain wall to cover an existing wall, it's necessary to apply tiles 18 to only one side of the module as needed.

The depth or thickness of the module can be selected by varying the width of frame 12 (*see also frame 12a, FIG. 17A*). For example, as will be described below, the modules can house a rear projection or digital video system and the greater depth is needed to enclose the componentry.

With reference to FIGS. 3, 4, 5 28 and 29, each end frame 12 and 17 includes a pair of rearwardly extending L-shaped flanges 23 that align vertically with correspondingly positioned and shaped flanges 23 on opposite end frame 12 or 17 so that frames 12 and 17 can be connected together by connecting strips ("zippers") 25. If the adjacent module 20 itself comprises an end frame 12 as shown in FIGS. 28 and 29, flanges 23 will abut and will be connected together in the same manner using zippers 25. As shown most clearly in FIG. 28, each of flanges 23 is formed with a bead 27. Each zipper 25 is generally T-shaped in cross-sectional shape and includes a central spine 29 that fits between flanges 23 and a pair of flexible arms 30 on opposite sides of the spine. Each

arm includes a bead 31 that snap fits with beads 27 on flanges 23 for a secure but releasable connection. When two adjacent modules are connected together in this way, there is enough of a gap between them that the zippers can be accessed for removal, allowing an individual module to be removed should the need arise.

As illustrated in FIGS. 28 and 29, each zipper can also include a pair of flexible extended fins 32 extending rearwardly from the spine 29. Depending on the application, a user may wish adjacent modules to be abutted together completely or to have a gap between them. In FIG. 28, a gap exists between the modules, and this gap is sealed using extending fins 32. As will be appreciated by those skilled in the art, the width of the gap is variable since extensions 32 are flexible and can accommodate various widths.

If no gap is desired, or if tiles span adjacent modules, FIG. 29 illustrates an embodiment having adjacent panels. In this case extensions 32 are behind each panel, and the force of extensions 32 against the rearward side of the module creates an acoustic seal for the wall.

In an alternative embodiment illustrated in FIG. 30, it is also possible to have a zipper 25 without extensions 32. This may be desirable when modules 20 abut and an acoustical seal is not required.

As such, in various embodiments, the zipper 25 may be positioned in a recessed location within the wall system 10, as illustrated. The recessed zipper 25 may allow for a single tile 18 to span multiple modules 20 without interference from the zipper 25. Additionally, a recessed zipper 25 may allow for the free movement of accessories 47 between adjacent wall modules 20 within a cantilever channel 41.

FIG. 5 shows an end piece 35 similar to end frame 17 but lacking notch 19. This end piece is therefore used to finish the vertical edge of module 20 using zippers 25 if no additional module is to be connected to it.

If either of frames 12 or 17 is to start, or end, at an existing wall, flexible starter strips 37 can snap-fit onto flanges 23 as shown most clearly in FIG. 6. Starter strips 37 include curved flexible gaskets 38 which will conform to the shape of the existing wall and will provide sound and light barriers. This can also be seen in FIGS. 24 and 32.

Alternatively, as illustrated in FIGS. 25 and 31, a wall start 43 can be mounted to an existing wall to provide a start to a module. Wall start 43 is preferably an aluminum extrusion mounted vertically to an existing wall using known mounting techniques. The mounting technique of screws shown in FIG. 25 is not meant to be limiting.

Wall start 43 includes a flanges 23 and is connected to an end frame 12 or 17 using a zipper 25. As indicated above, extensions 32 can provide a seal against the wall and panel.

To increase the height of an existing module 20, or to combine a glass module above or below a tile-clad module, a spline 39 can be used to connect end frame 12 (or 17) to an extension frame 12e as shown most clearly in FIG. 7. Actually, as shown in this figure, extension frame 12e is a length of frame 17, which allows the lower portion of the wall to be hung with standard tiles and the upper extended portion of the wall to be finished in a glass or plastic divider 14 (*e.g., within notch 19 of either frame 17*) for a combination of finished looks. The upper and lower extrusions 90 (*comprising notch 92, see also FIG. 15*), which complete the framing of divider 14, will be described below in connection with a levelling system in which the same extrusion is used.

It is desirable that work surfaces, mill work and wall accessories such as trays or document holders be connectable to modules 20. This can be easily achieved in the present system by using cantilever channel stringers 40 with

channel brackets horizontally disposed in the channel between adjacent tiles **18** as shown most clearly in FIGS. **8** and **9**.

Each channel stringer **40** includes a central horizontally extending channel portion **41** with a generally L-shaped slot **42** formed along its length adapted to receive and engage a substantially L-shaped hook **45** formed on a wall accessory **47** such as the document holder shown in FIG. **8**. A pair of diagonally extending webs **49** connects channel portion **41** to upper and lower portions **51** and **53** respectively. Each portion includes a tile support **55** that is the connection point for the tiles **18** that are mounted above and below channel portion **41**. *The tiles are connected to the channel stringers via opposing snap-fit tile connectors.* More specifically, the upper and lower edges of tiles **18** are provided with a [connector strip **60**] *tile connector in the form of a tile clip (connector strip 60), which is attached by means of screws, adhesive or any other suitable fastening to the rear surface of tile 18, as illustrated.* Each connector strip **60** includes a pair of opposed flexible arms **62** to snap-fit with [a generally arrow shaped bead **64**] *another wall tile support in the form of a protrusion (a generally arrow shaped bead 64) formed along the edge of flanges 67 that are formed on and extend the length of each upper and lower portion 51 and 53.* This allows individual tiles **18** to be removed or replaced without having to disassemble the entire wall. The flanges **23** formed on vertical end frames **12** and **17** that are connected together by zippers **25** are located sufficiently inwardly that the zippers will not interfere with the continuity of slot **42** from one module to the next so that wall accessories, mill work or work surfaces can be connected or moved between modules without interference.

The upper and lower edges of tiles **18** that abut channel portion **41** of each channel bracket are camphored for clearance as seen most clearly in FIG. **9**.

The upper and lower portions **51** and **53** of the channel stringer **40** are advantageously formed with longitudinally extended circular recesses **57** and inner channels **58**. Recesses **57** are adapted to receive screws used to connect end frames **12** or **17** to channel stringers **40**. Channels **58** can be used to support mounting hardware for audio-video equipment mounted within the modules, cable management clips or any other hardware to be housed or contained in the module's interior. Channels **58** are also used to connect a single-sided tile clad module to brackets attached to existing wall surfaces.

With reference to FIG. **10**, another embodiment of the invention is shown incorporating a section of standard slat wall **69** including slats **70** and slat wall channels **71** for connection to all slat wall accessories **47**. Slat wall panels can make up some or all of the panels incorporated into any one module **20** and the modules themselves are configured for use with end frames **12** and zippers **25** so that the modules themselves can be connected together in any desired combination. Slat wall modules can be one (FIG. **11**) or two sided (FIG. **10**) for use as either dividing or curtain walls.

As shown in FIG. **12**, in the applicant's related panel furniture system, a work surface or desktop **76** can be connected to modules **20**. The desktop **76** can hook into either cantilevered channel stringers **40** or into slat wall channels **71** and otherwise the construction of the individual modules **20** is the same as described above for wall system **10**. Furniture legs **80** shown in the example of FIG. **12** consist of a vertical frame **12** zipper connected to a finishing end extrusion **35** using zippers **25** as shown in FIG. **13**, in the same manner as the wall system **10**. The lower end of each

furniture leg **80** is finished with a concentric sleeve **79** which conceals a threaded bolt **84** in the lower end of each leg which can be used for levelling.

As illustrated in FIG. **23**, three vertical extrusions **2310** are connected to each other to create the connection point for the three wall systems, and each wall meets the others at an angle of 120 degrees.

In the case of modules having tiles that extend all the way down to the floor, applicant has developed a leveller mounting system that allows levellers to be placed anywhere along the length of a module and extra levellers to be added where needed. There are two variations of the leveller mounting system shown in FIGS. **15** and **16**, one to be used with modules comprising tiles **18**, and the other with modules using glass or plastic dividers.

Referring first to FIG. **15**, this is the levelling system to be used with modules having glass or plastic dividers extending down to floor level. This system includes a structural extrusion **90**, which is generally an inverted U-shaped channel with a notch **92** to engage the lower edge of the glass or plastic divider, and a universal foot **100**.

Extrusion **90** and universal foot **100** are interconnected by means of dual threaded levellers **110**, an example of which is shown in FIG. **14**.

Leveller **110** has three distinct sections, an upper section **112**, a middle section **115** and a lower section **120**. Upper section **112** is cylindrical in shape and is internally left or right hand threaded. A plate **113** is connected to the section's upper end for a permanent connection thereto. Middle section **115** is both internally and externally threaded. The external threads will match the direction of the internal threads on upper section **112** while the internal threads will be in the opposite direction to match the external threading of lower portion **120**. A fixed middle nut **114** is disposed at the lower end of middle section **115**. Nut **114** can be used to turn middle section **115** relative to the upper and lower sections of the leveller.

As mentioned, the lower section **120** of the leveller is externally threaded and the threading will be in the opposite direction to the internal threading of upper section **112**. In this way, each turn of nut **114** doubles the expansion or contraction of the leveller to halve the levelling time. The lower end of section **120** includes its own fixed adjustment nut **124** and an inverted V-shaped lower plate **125**.

FIG. **15** shows how leveller **110** is installed. Plate **113** aligns with channels **94** in extrusion **90** to be slidable along the length of the channel to any desired location. The V-shaped lower plate **125** aligns with and slides into grooves **101** in foot **100**. Those levellers that fit at the end of a foot are slightly modified to include tabs **126** at the outer corners of plate **125** which prevent the plate from moving inwardly. When vertical end frames **12** or **17** are attached to extrusion **90**, plate **113** is prevented from moving outwardly so that the leveller is held in its position at the very end of foot **100**. Frames **12** or **17** are connected to extrusion **90** by means of screws that thread into one or more of circular slots **117** in the extrusion.

If modules **20** are situated atop carpet, toothed carpet grippers **130** are inserted into slots **129** in foot **100**. If the modules are installed on hard surfaces, nonskid grippers can be inserted instead. The grippers can be placed precisely where needed to bear the modules weight and can be easily moved, replaced or switched over as needed.

FIG. **16** shows a leveller **110** installed on modules **20** and illustrates the installation of base trim **140** used to conceal the levellers **110** when they're not being adjusted. In this view, plate **113** is again slidingly received into channels

formed in the module's lowermost extrusion and plate **125** is received into grooves **101** in foot **100**. The base trim **140** includes baseboards **142** and snap pieces **144**. Snap pieces **144** snap-fit onto foot **100** as shown with grooves **145** and **147** on the snap piece engaging flanges **108** and **109** on the foot. Each snap piece includes a longitudinally extending elevated hook **149** and a similarly longitudinally extending channel **150**. Each baseboard includes a hook **143** to engage hook **149** on the snap piece, and a bead **153** that snap fits into channel **150** to retain the baseboards in a vertical position to provide a finished look. Because the baseboards are installed usually after the modules have been assembled together, the boards can span multiple modules for longer runs and fewer seams.

Reference is now made to FIGS. **26** and **27**. As illustrated, besides the bottom connection with the leveller (as described with relation to FIGS. **15** and **16** above), a ceiling connection is also preferred.

FIG. **26** shows a ceiling connection for a solid wall, such as those described above having tile cladding. A ceiling track **2601** is affixed to the ceiling above the area for the desired wall. Each module includes two horizontal uppers **2610** abut thereto (on either side of the ceiling track), the horizontal upper including an upper flange **2612**. A ceiling trim **2614** is affixed to upper flange **2612**. Ceiling trim **2614** is flexible and allows variable spacing of the wall with the ceiling. Specifically, the trim **2614** will flex to allow the wall to move closer or further from the wall as required based on levelling needs.

Horizontal upper **2610** further includes a [bead **64**] *protrusion (bead 64)* as described above to attach a tile (*via the flexible arms of the illustrated tile clips*) to the horizontal upper. Further, recesses **2616** are used to attach horizontal uppers to frames **12** or **17**.

To affix a wall, an installer can first install ceiling track **2601** in the correct location. The wall is then created with levellers **110** in a lowermost position. The levellers **110** are then extended to level the wall and to further cause horizontal uppers **2610** to abut ceiling track **2601** on either side of ceiling track **2601**, as illustrated in FIG. **26**.

Alternatively, if a divider such as a glass panel is being used, a one piece upper **2701** can be used, as illustrated in FIG. **27**. The one piece upper **2701** comprises a flange **2712** to connect a ceiling trim **2714** to. Ceiling trim **2714** is preferably the same as ceiling trim **2614**. Upper **2701** further includes a channel **2716** for receiving a divider.

The present wall system **10** includes curved walls using curved aluminum stringers and extrusions and curved tiles **18**. In conventional systems, curved walls are constructed of faceted panels rather than true, radii arcs. A curved wall is illustrated in FIG. **19**.

With reference to FIG. **17**, a module **20** is shown in which a couple of tiles **18** have been replaced with an integrated media panel **190**. The panel can be a Fresnel lens, a plasma screen, an LCD screen or a digital whiteboard. FIGS. **17A** and **17B** show how a vertical end frame of extended depth (**12B**) can be used to create more depth in the wall module itself. For example, FIG. **17B** shows vertical end frames **12**, **12a** of comparatively different depth, which can in turn be used as appropriate for the given depth of media panel **190**. Thus, the wall module of FIG. **1** contrasts with that **17A** by having vertical end frames **12**, **12a** of different depths, wherein the module of FIG. **17A** has greater depth than the module shown in FIG. **1**. Rear projection technology can be used to project images onto the Fresnel lens, or the digital whiteboard technology allows sketching, writing, layout or computer screen emulation. In the example shown, adjacent

tiles **18** incorporate speakers **192** to provide sound. Tile **18** surrounding the screen area can be used for integrated storage areas.

With reference to FIG. **18**, there is shown schematically a module **20** with an integrated media center **200** suspended therein.

Various connectors are also provided to allow the present reconfigurable wall system to form corners. Reference is now made to FIGS. **19**, **20**, **21** and **22**.

FIG. **19** illustrates a two-way rectilinear connector **1910**. Connector **1910** includes a finished outer surface on sides **1912** and **1914**. Further, flanges **23** are provided on sides **1916** and **1918**. Flanges **23** can be used with zipper **25** to connect to end frames **12** or **17**. An extension **1920** extends between sides **1916** and **1918** to form a finished corner once modules **20** are connected to these sides. Further, sides **1912** and **1914** include an elongate end **1922** for hiding zipper **25** and creating a finished surface.

FIG. **20** is similar to FIG. **19**, with the principle difference being the radial finished outer surface **2012** replacing sides **1912** and **1914**. Otherwise similar reference numerals are used between FIGS. **19** and **20**.

FIG. **21** illustrates a three way connector for a "T" connection. Three modules **20** are connected to connector **2101**. Connector **2101** includes a finished outer surface **2112**. Flanges **23** are used to connect modules **20**. Extensions **1920** provide a finished look between adjacent modules **20**. Further, elongate end **1922** provides a finished look on the outside of the wall.

FIG. **22** illustrates an alternative 90 degree connector. In this case, an extrusion **2201** is affixed to the end of a module **20**. Two extrusions are connected using a connector **2312**. Since connector **2312** is flexible, an angle greater than or less than 90 degrees is possible. In a preferred embodiment, the swing on the connector is approximately 15 degrees.

The above-described embodiments of the present invention are meant to be illustrative of preferred embodiments and are not intended to limit the scope of the present invention. Various modifications, which would be readily apparent to one skilled in the art, are intended to be within the scope of the present invention. The only limitations to the scope of the present invention are set forth in the following claims appended hereto.

What is claimed is:

- [1.** A movable reconfigurable wall system comprising:
 - a) at least one wall module having a front and rear surface and top, bottom, right side and left side edges, said at least one wall module having:
 - i) a vertical end frame disposed adjacent to each of said right and left side edges, each vertical end frame having a first vertically extending flange and a spaced apart second vertically extending flange thereon, each of said first vertically extending flange and said second vertically extending flange having a beaded portion, the beaded portion on one of said first vertically extending flange or said second vertically extending flange extending toward the front surface of the wall module and the beaded portion on the other of said first vertically extending flange or said second vertically extending flange extending toward the rear surface of the wall module;
 - ii) a plurality of horizontal stringers affixed between said vertical end frames at said right and left side edges; and
 - iii) an aesthetic surface affixed to said stringers; and
 - b) a removable connecting strip having a pair of spaced apart flexible arms, each arm having a beaded portion

11

thereon, the beaded portion of one of said arms being adapted to connect releasably to the beaded portion of one of said first vertically extending flange or said second vertically extending flange on said vertical end frame and the beaded portion of the other of said arms being adapted to connect releasably to the beaded portion of a corresponding opposed vertically extending flange on a separate vertical end frame of a second wall module, a wall bracket, a finishing trim or a connection post to hold one of said first vertically extending flange or said second vertically extending flange and said opposed vertically extending flange together, the beaded portions of said first vertically extending flange or said second vertically extending flange and said opposed vertically extending flange fitting inside the arms of said connecting strip to hold said first vertically extending flange or said second vertically extending flange and said opposed vertically extending flange together thereby releasably connecting said at least one wall module to the other of said second wall module, wall bracket, finishing trim or connection post.]

2. The movable reconfigurable wall system of claim [1] 8, wherein said connecting strip includes a spine adapted to fit between said first vertically extending flange or said second vertically extending flange and said opposed vertically extending flange.

3. The movable reconfigurable wall system of claim [2] 8, wherein said connecting strip further includes a pair of flexible fin extensions extending opposite to said flexible arms for providing a seal.

4. The movable reconfigurable wall system of claim [1] 8, wherein said aesthetic surface includes a tile panel on said front surface, said rear surface, or both said front surface and said rear surface.

5. The movable reconfigurable wall system of claim 4, wherein each said stringer includes one or more protrusions, said reconfigurable wall system further including tile clips for affixing tiles to said one or more protrusions.

6. The movable reconfigurable wall system of claim [1] 8, wherein said aesthetic surface is a single divider selected from a group consisting of substrates consisting of glass, plastic, or wood and metal.

7. The movable reconfigurable wall system of claim 6, wherein said stringers and *the first and second vertical end frames* include a channel for receiving said divider.

8. [The movable reconfigurable wall system of claim 1.] *A movable reconfigurable wall system comprising:*

a) *at least one wall module having a front and rear surface and top, bottom, right side and left side edges, said at least one wall module having:*

i) *a first vertical end frame disposed adjacent to the right side edge and a second vertical end frame disposed adjacent to the left side edge, each of the first and the second vertical end frames having a first vertically extending flange and a spaced apart second vertically extending flange thereon, each of said first vertically extending flange and said second vertically extending flange having a beaded portion, the beaded portion on one of said first vertically extending flange or said second vertically extending flange extending toward the front surface of the wall module and the beaded portion on the other of said first vertically extending flange or said second vertically extending flange extending toward the rear surface of the wall module;*

12

ii) *a plurality of horizontal stringers affixed between said vertical end frames at said right and left side edges; and*

iii) *an aesthetic surface affixed to said stringers; and*

b) *a removable connecting strip having a pair of spaced apart flexible arms, each arm having a beaded portion thereon, the beaded portion of one of said arms being adapted to connect releasably to the beaded portion of one of said first vertically extending flange or said second vertically extending flange on said first or second vertical end frame and the beaded portion of the other of said arms being adapted to connect releasably to the beaded portion of a corresponding opposed vertically extending flange on a separate vertical end frame of a second wall module, a wall bracket, a finishing trim, or a connection post to hold one of said first vertically extending flange or said second vertically extending flange and said opposed vertically extending flange together, the beaded portions of said first vertically extending flange or said second vertically extending flange and said opposed vertically extending flange fitting inside the arms of said connecting strip to hold said first vertically extending flange or said second vertically extending flange and said opposed vertically extending flange together thereby releasably connecting said at least one wall module to the other of said second wall module, wall bracket, finishing trim or connection post;*

wherein said stringers include a cantilever channel stringer, said cantilever channel stringer having:

a central horizontally extending channel portion with a generally L-shaped slot, said L-shaped slot adapted to receive and engage a substantially L-shaped hook formed on a wall accessory;

an upper portion having a tile support;

a lower portion having a tile support; and

a pair of extending webs connecting said channel portion to said upper and a lower portion.

9. The movable reconfigurable wall system of claim [1] 8, wherein said system further comprises an extension frame, said extension frame including a pair of vertical extension end frames and at least one stringer, said extension frame being affixed atop of said at least one module with a spline [on each end of said end frame] *connecting each of said vertical extension end frames to one of said first vertical end frame and said second vertical end frame.*

10. The movable reconfigurable wall system of claim [1] 8, wherein said aesthetic surface includes a slat wall, said slat wall having slats and slat wall channels for connection to slat wall accessories.

11. [The movable reconfigurable wall system of claim 1, said system further comprising] *A movable reconfigurable wall system comprising:*

a) *at least one wall module having a front and rear surface and top, bottom, right side and left side edges, said at least one wall module having:*

i) *a first vertical end frame disposed adjacent to the right side edge and a second vertical end frame disposed adjacent to the left side edge, each of the first and the second vertical end frames having a first vertically extending flange and a spaced apart second vertically extending flange thereon, each of said first vertically extending flange and said second vertically extending flange having a beaded portion, the beaded portion on one of said first vertically extending flange or said second vertically extending flange extending toward the front surface of the wall*

13

module and the beaded portion on the other of said first vertically extending flange or said second vertically extending flange extending toward the rear surface of the wall module;

ii) *a plurality of horizontal stringers affixed between said vertical end frames at said right and left side edges; and*

iii) *an aesthetic surface affixed to said stringers; and*

b) *a removable connecting strip having a pair of spaced apart flexible arms, each arm having a beaded portion thereon, the beaded portion of one of said arms being adapted to connect releasably to the beaded portion of one of said first vertically extending flange or said second vertically extending flange on said first or second vertical end frame and the beaded portion of the other of said arms being adapted to connect releasably to the beaded portion of a corresponding opposed vertically extending flange on a separate vertical end frame of a second wall module, a wall bracket, a finishing trim, or a connection post to hold one of said first vertically extending flange or said second vertically extending flange and said opposed vertically extending flange together, the beaded portions of said first vertically extending flange or said second vertically extending flange and said opposed vertically extending flange fitting inside the arms of said connecting strip to hold said first vertically extending flange or said second vertically extending flange and said opposed vertically extending flange together thereby releasably connecting said at least one wall module to the other of said second wall module, wall bracket, finishing trim or connection post;*

a levelling system having:

a universal foot;

a leveller capable of engaging said universal foot; and

a structural extrusion to engage surface of said at least one module, said structural extrusion connecting to said leveller, wherein said leveller provides the sole connection between said universal foot and said module.

12. The movable reconfigurable wall system of claim 11, wherein said leveller comprises: a cylindrical internally threaded upper section; an internally and externally threaded middle section, said external threads matching said internally threaded upper section; and an externally threaded lower section, said externally threaded lower section matching internal threads of said middle section, wherein said middle section can be twisted to extend or contract said leveller.

13. The movable reconfigurable wall unit of claim 11 further comprising a base trim, said base trim attaching to said universal foot.

14. The movable reconfigurable wall unit of claim 1, further comprising a ceiling connection, said ceiling connection including:

a ceiling track affixed to a ceiling;

a horizontal upper section affixed to said module, said horizontal upper section adapted to fit about said ceiling track; and

a flexible gasket affixed to said horizontal upper section and extending above said horizontal upper section to contact the ceiling.

15. The movable reconfigurable wall unit of claim 1, wherein said wall bracket comprises:

an extrusion for connection to an existing wall in alignment with [said] at least one of the two vertical end [frame] frames; and

14

first and second flanges on said extrusion corresponding to said first vertically extending flange and said second vertically extending flange on said at least one of the two vertical end [frame] frames and arranged in opposition thereto.

16. The movable reconfigurable wall unit of claim 1, further comprising a wall joint, said wall joint comprising a flexible gasket and a channel, said channel adapted to connect to a flange of said at least one module.

17. The movable reconfigurable wall unit of claim 1, wherein said at least one module includes curved stringers and curved aesthetic surfaces.

18. The movable reconfigurable wall unit of claim 1, wherein said connection post includes at least two sides having vertically extending flanges thereon corresponding to and arranged in opposition to said first and second flanges on [said] at least one of the two vertical end [frame] frames.

19. The movable reconfigurable wall unit of claim 1, wherein said aesthetic surface includes a multimedia component.

20. The movable reconfigurable wall unit of claim 19, wherein said multimedia component is a video monitor.

21. [The movable reconfigurable wall unit of claim 1,] A movable reconfigurable wall system comprising:

a) *at least one wall module having a front and rear surface and top, bottom, right side and left side edges, said at least one wall module having:*

i) *a first vertical end frame disposed adjacent to the right side edge and a second vertical end frame disposed adjacent to the left side edge, each of the first and the second vertical end frames having a first vertically extending flange and a spaced apart second vertically extending flange thereon, each of said first vertically extending flange and said second vertically extending flange having a beaded portion, the beaded portion on one of said first vertically extending flange or said second vertically extending flange extending toward the front surface of the wall module and the beaded portion on the other of said first vertically extending flange or said second vertically extending flange extending toward the rear surface of the wall module;*

ii) *a plurality of horizontal stringers affixed between said vertical end frames at said right and left side edges; and*

iii) *an aesthetic surface affixed to said stringers; and*

b) *a removable connecting strip having a pair of spaced apart flexible arms, each arm having a beaded portion thereon, the beaded portion of one of said arms being adapted to connect releasably to the beaded portion of one of said first vertically extending flange or said second vertically extending flange on said first or second vertical end frame and the beaded portion of the other of said arms being adapted to connect releasably to the beaded portion of a corresponding opposed vertically extending flange on a separate vertical end frame of a second wall module, a wall bracket, a finishing trim, or a connection post to hold one of said first vertically extending flange or said second vertically extending flange and said opposed vertically extending flange together, the beaded portions of said first vertically extending flange or said second vertically extending flange and said opposed vertically extending flange fitting inside the arms of said connecting strip to hold said first vertically extending flange or said second vertically extending flange and said opposed vertically extending flange together*

15

thereby releasably connecting said at least one wall module to the other of said second wall module, wall bracket, finishing trim or connection post;

wherein said vertical end frame depth is extended to provide a deeper wall.

22. The movable reconfigurable wall unit of claim 21, wherein said deeper wall is adapted to accommodate a rear-projection video system.

23. The movable reconfigurable wall unit of claim 21, wherein said deeper wall is adapted to accommodate an integrated storage system.

24. The movable reconfigurable wall unit of claim [1] 8, further comprising a wall mounted module for mounting to an existing wall face, said wall mounted module having: a) vertical end brackets disposed at least at its side edges, each said vertical end frame having a vertically extending flange directed away from said existing wall face; b) a plurality of horizontal stringers affixed between said pair of vertical end brackets; and c) an aesthetic surface affixed to said stringers.

25. The movable reconfigurable wall unit of claim [1] 8, further comprising a furniture system connectable to said at least one module, the furniture system having: a work surface, said work surface connectable to said stringers; and furniture legs, said furniture legs connecting to said work surface at a first end and connecting to a threaded bolt at a second end opposite said first end, said threaded bolt allowing levelling of said work surface.

26. A movable reconfigurable wall system comprising:

a first wall module having a first vertical end frame disposed adjacent a left edge of the first wall module and a second vertical end frame disposed adjacent a right edge of the first wall module, the second vertical end frame comprising at least one vertically extending flange, the flange having a beaded portion extending therefrom;

a first plurality of horizontal stringers interconnecting the first vertical end frame of the first wall module and the second vertical end frame of the first wall module;

a second wall module having a first vertical end frame disposed adjacent a left edge of the second wall module and a second vertical end frame disposed adjacent a right edge of the second wall module, the first vertical end frame comprising at least one vertically extending flange, the flange having a beaded portion extending therefrom;

a second plurality of horizontal stringers interconnecting the first vertical end frame of the second wall module and the second vertical end frame of the second wall module;

a removable connecting strip comprising a pair of spaced apart flexible arms each having a beaded portion thereon, the connecting strip releasably connected to the beaded portion extending from the flange of the second vertical end frame of the first wall module and releasably connected to the beaded portion extending from the flange of the first vertical end frame of the second wall module, such that the removable connecting strip connects the first wall module to the second wall module; and

a wall tile affixed to at least one of the first plurality of horizontal stringers and the second plurality of horizontal stringers via wall tile connectors;

wherein at least one of the first plurality of horizontal stringers and the second plurality of horizontal stringers include a cantilever channel stringer, the cantilever channel stringer having:

16

a horizontally extending channel portion with a generally L-shaped slot, the L-shaped slot adapted to receive and engage a substantially L-shaped hook formed on a wall accessory; and

a wall tile support.

27. The movable reconfigurable wall system as recited in claim 26, wherein:

the wall tile support spans a length of the cantilever channel stringer; and

a right edge of the wall tile support in the first wall module substantially aligns with a left edge of a wall tile support of the second wall module when the first wall module is connected to the second wall module.

28. The movable reconfigurable wall system as recited in claim 27, wherein the wall tile comprises a connector strip with a pair of opposed flexible arms that attach to a bead of the wall tile support.

29. The movable reconfigurable wall system as recited in claim 26, further comprising:

a multimedia center suspended within the first wall module or within the second wall module;

wherein a front face of the multimedia center does not extend beyond a front face of the wall tile.

30. The modular wall system as recited in claim 26, further comprising:

a leveling system having:

a foot;

a leveler engaging and supported by said foot and engaging and supporting a horizontal member in said at least one module;

wherein said leveler

(a) has a height that is capable of being adjusted and

(b) has a horizontal location that was established by sliding said leveler horizontally relative to, and while engaging, said horizontal member and/or said foot.

31. The movable reconfigurable wall system of claim 30, wherein the leveler comprises:

a cylindrical internally threaded upper section;

an internally and externally threaded middle section, the external threads matching the internally threaded upper section; and

an externally threaded lower section, the externally threaded lower section matching internal threads of the middle section, wherein the middle section can be twisted to extend or contract the leveler.

32. The modular wall system as recited in claim 26, wherein:

the wall tile connectors comprise a connector strip with a pair of opposed flexible arms;

the wall tile support comprises a beaded portion;

the flexible arms of the connector strip of the wall tile snap-fit to the beaded portion of the wall tile support; and

the wall tile support provides an attachment interface that is parallel to the first or second plurality of horizontal stringers.

33. The modular wall system as recited in claim 26, wherein each of the first and second plurality of horizontal stringers comprises a cantilever channel stringer, further comprising:

a wall accessory mounted to and cantilevering from a cantilever channel stringer of the first and second plurality of horizontal stringers;

wherein the wall accessory extends beyond a front surface of the wall tile.

34. The modular wall system as recited in claim 33, wherein:

the removable connecting strip is positioned sufficiently inwardly of the channel portion of the cantilever channel stringers of the first and second wall modules, such that the wall accessory can be moved between the first and second wall modules without interference with the removable connecting strip.

35. The movable reconfigurable wall system of claim 26, wherein said wall tile comprises a material selected from a group consisting of glass, plastic, wood, and metal.

36. The movable reconfigurable wall system of claim 35, wherein said stringers and the first and second vertical end frames further include a channel for receiving a divider comprising a material selected from the group consisting of glass, plastic, wood, and metal.

37. The movable reconfigurable wall system of claim 26, wherein:

the system further comprises an extension frame;

the extension frame includes a pair of vertical extension end frames and at least one stringer, and

the extension frame is affixed atop of the at least one wall module with a spline affixed adjacent to a first side and a second side of the at least one wall module.

38. The modular wall system as recited in claim 26, further comprising a ceiling connection, the ceiling connection including:

a ceiling track affixed to a ceiling;

a horizontal upper section affixed to the module, the horizontal upper section adapted to fit about the ceiling track; and

a flexible gasket affixed to the horizontal upper section and extending above the horizontal upper section to contact the ceiling.

39. The modular wall system as recited in claim 26, wherein:

the wall tile is affixed to one or more of the first plurality of horizontal stringers and to one or more of the second plurality of horizontal stringers;

the wall tile spans at least a portion of both the first wall module and the second wall module.

40. The modular wall system as recited in claim 26, further comprising:

a wall accessory mounted in a cantilever manner to the first wall module within the corresponding cantilever channel stringer; and

the wall accessory extends beyond a front surface of the wall tile.

41. The movable reconfigurable wall system as recited in claim 26, further comprising a multimedia center suspended within the first wall module or within the second wall module.

42. The movable reconfigurable wall system as recited in claim 41, wherein a front face of the multimedia center is flush with a front face of the wall tile.

43. The movable reconfigurable wall system as recited in claim 41, wherein the multimedia center comprises a video monitor.

44. The movable reconfigurable wall system as recited in claim 26, wherein:

each of the first and second plurality of horizontal stringers further comprises an intermediate horizontal stringer affixed between the vertical end frames of the corresponding first or second wall modules; and

each of the intermediate horizontal stringers is positioned below an upper horizontal stringer and above a lower horizontal stringer.

45. The movable reconfigurable wall system as recited in claim 44, wherein:

each of the intermediate horizontal stringers comprises a horizontally extending cantilever channel portion for receiving wall accessories.

46. The movable reconfigurable wall system as recited in claim 44, wherein:

each of the intermediate horizontal stringers comprises a wall tile support extending a horizontal length of the respective intermediate horizontal stringer;

the wall tile is connected to a plurality of the wall tile supports through a snap-fit connection.

47. The movable reconfigurable wall system of claim 46, wherein a depth associated with the vertical end frames of the first wall module is deeper than a depth associated with the vertical end frames of the second wall module, such that the first wall module comprises a deeper wall.

48. The movable reconfigurable wall system of claim 47, wherein said deeper wall is adapted to accommodate a rear-projection video system, or an integrated storage system.

49. The movable reconfigurable wall system as recited in claim 44, wherein the removable connecting strip is recessed behind an outermost portion of the intermediate horizontal stringer.

50. A movable reconfigurable wall system comprising:

a) at least one wall module having a front and rear surface and top, bottom, right side and left side edges, the at least one wall module having:

i) a first vertical end frame disposed adjacent to the right side edge and a second vertical end frame disposed adjacent to the left side edge, each of the first and the second vertical end frames having a first vertically extending flange and a spaced apart second vertically extending flange thereon, each of the first vertically extending flange and the second vertically extending flange having a beaded portion, the beaded portion on one of the first vertically extending flange or the second vertically extending flange extending toward the front surface of the wall module and the beaded portion on the other of the first vertically extending flange or the second vertically extending flange extending toward the rear surface of the wall module;

ii) a plurality of horizontal stringers affixed between the vertical end frames at the right and left side edges;

iii) a wall tile affixed to the stringers; and

b) a removable connecting strip having a pair of spaced apart flexible arms, each arm having a beaded portion thereon, the beaded portion of one of the arms being adapted to connect releasably to the beaded portion of one of the first vertically extending flange or the second vertically extending flange on the first or second vertical end frame and the beaded portion of the other of the arms being adapted to connect releasably to the beaded portion of a corresponding opposed vertically extending flange on a separate vertical end frame of a second wall module, a wall bracket, a finishing trim, or a connection post to hold one of the first vertically extending flange or the second vertically extending flange and the opposed vertically extending flange together, the beaded portions of the first vertically extending flange or the second vertically extending flange and the opposed vertically extending flange connecting to the arms of the connecting strip to hold the first vertically extending flange or the second vertically extending flange and the opposed vertically extending flange together thereby releasably connect-

19

ing the at least one wall module to the other of the second wall module, wall bracket, finishing trim or connection post;

wherein at least one of the plurality of horizontal stringers includes a cantilever channel stringer, the cantilever channel stringer having:

a horizontally extending channel portion with a generally L-shaped slot, the L-shaped slot adapted to receive and engage a substantially L-shaped hook formed on a wall accessory; and

a wall tile support.

51. The movable reconfigurable wall system as recited in claim 50, further comprising:

a leveling system having:

a foot;

a leveler engaging and supported by said foot and engaging and supporting a horizontal member in said at least one module;

wherein said leveler:

(a) has a height that is capable of being adjusted; and

(b) has a horizontal location that was established by sliding said leveler horizontally relative to, and while engaging, said horizontal member and/or said foot.

52. A movable reconfigurable wall system comprising:

a) at least one wall module having a front and rear surface and top, bottom, right side and left side edges, the at least one wall module having:

i) a first vertical end frame disposed adjacent to the right side edge and a second vertical end frame disposed adjacent to the left side edge, each of the first and the second vertical end frames having a first vertically extending flange and a spaced apart second vertically extending flange thereon, each of the first vertically extending flange and the second vertically extending flange having a beaded portion, the beaded portion on one of the first vertically extending flange or the second vertically extending flange extending toward the front surface of the wall module and the beaded portion on the other of the first vertically extending flange or the second vertically extending flange extending toward the rear surface of the wall module;

ii) a plurality of horizontal stringers affixed between the vertical end frames at the right and left side edges;

iii) a wall tile affixed to the at least one wall module; and

b) a removable connecting strip having a pair of spaced apart flexible arms, each arm having a beaded portion thereon, the beaded portion of one of the arms being adapted to connect releasably to the beaded portion of one of the first vertically extending flange or the second vertically extending flange on the first or second vertical end frame and the beaded portion of the other of the arms being adapted to connect releasably to the beaded portion of a corresponding opposed vertically extending flange on a separate vertical end frame of a second wall module, a wall bracket, a finishing trim, or a connection post to hold one of the first vertically extending flange or the second vertically extending flange and the opposed vertically extending flange together, the beaded portions of the first vertically extending flange or the second vertically extending flange and the opposed vertically extending flange fitting inside the arms of the connecting strip to hold the first vertically extending flange or the second vertically extending flange and the opposed vertically extending flange together thereby releasably connecting the at

20

least one wall module to the other of the second wall module, wall bracket, finishing trim or connection post; wherein the horizontal stringers include a cantilever channel stringer, the cantilever channel stringer having:

a horizontally extending channel portion with a slot, the slot adapted to receive and engage a hook formed on a wall accessory;

wherein the wall accessory cantilevers from the slot.

53. The movable reconfigurable wall system as recited in claim 52, further comprising:

a leveling system having:

a foot;

a leveler engaging and supported by said foot and engaging and supporting a horizontal member in said at least one module;

wherein said leveler:

(a) has a height that is capable of being adjusted; and

(b) has a horizontal location that was established by sliding said leveler horizontally relative to, and while engaging, said horizontal member and/or said foot.

54. A movable reconfigurable wall system comprising:

a first wall module having a first vertical end frame disposed adjacent a left edge of the first wall module and a second vertical end frame disposed adjacent a right edge of the first wall module, the second vertical end frame comprising at least one vertically extending flange, the flange having a beaded portion extending therefrom;

a first plurality of horizontal stringers interconnecting the first vertical end frame of the first wall module and the second vertical end frame of the first wall module;

a second wall module having a first vertical end frame disposed adjacent a left edge of the second wall module and a second vertical end frame disposed adjacent a right edge of the second wall module, the first vertical end frame comprising at least one vertically extending flange, the flange having a beaded portion extending therefrom;

a second plurality of horizontal stringers interconnecting the first vertical end frame of the second wall module and the second vertical end frame of the second wall module;

a removable connecting strip comprising a pair of spaced apart flexible arms each having a beaded portion thereon, the connecting strip releasably connected to the beaded portion extending from the flange of the second vertical end frame of the first wall module and releasably connected to the beaded portion extending from the flange of the first vertical end frame of the second wall module, such that the removable connecting strip connects the first wall module to the second wall module; and

a wall tile affixed to one or more of the first plurality of horizontal stringers and to one or more of the second plurality of horizontal stringers via wall tile connectors, such that the wall tile spans at least a portion of both the first wall module and the second wall module.

55. The movable reconfigurable wall system as recited in claim 54, wherein:

the wall tile connectors comprise one or more connector strips with a pair of opposed flexible arms; and

the wall tile connectors connect the wall tile to beaded wall tile supports extending from both of the first plurality of horizontal stringers and the second plurality of horizontal stringers.