



US00RE48695E

(19) **United States**  
(12) **Reissued Patent**  
**Zhang et al.**

(10) **Patent Number:** **US RE48,695 E**  
(45) **Date of Reissued Patent:** **Aug. 17, 2021**

(54) **TRANSPARENT OLED DEVICE AND DISPLAY DEVICE EMPLOYING SAME**

(71) Applicants: **BEIJING VISIONOX TECHNOLOGY CO., LTD.**, Beijing (CN); **TSINGHUA UNIVERSITY**, Beijing (CN)

(72) Inventors: **Guohui Zhang**, Beijing (CN); **Mengzhen Li**, Beijing (CN); **Man Li**, Beijing (CN); **Lian Duan**, Beijing (CN)

(73) Assignees: **BEIJING VISIONOX TECHNOLOGY CO., LTD.**, Beijing (CN); **TSINGHUA UNIVERSITY**, Beijing (CN)

(21) Appl. No.: **16/412,454**

(22) Filed: **May 15, 2019**

**Related U.S. Patent Documents**

Reissue of:

(64) Patent No.: **9,692,006**  
Issued: **Jun. 27, 2017**  
Appl. No.: **15/109,410**  
Filed: **Jun. 30, 2016**

U.S. Applications:

(63) Continuation of application No. 15/109,410, filed on Jun. 30, 2016, now Pat. No. 9,692,006.

(30) **Foreign Application Priority Data**

Dec. 31, 2013 (CN) ..... 201310749017.2

(51) **Int. Cl.**  
**H01L 51/52** (2006.01)  
**H01L 27/32** (2006.01)

(52) **U.S. Cl.**  
CPC ..... **H01L 27/3276** (2013.01); **H01L 51/5218** (2013.01); **H01L 27/326** (2013.01);  
(Continued)

(58) **Field of Classification Search**  
CPC ..... H01L 51/5218; H01L 27/3276; H01L 51/5206

See application file for complete search history.

(56) **References Cited**

**U.S. PATENT DOCUMENTS**

8,461,592 B2 6/2013 Ha et al.  
2003/0156239 A1\* 8/2003 Inoue ..... G02F 1/13353  
349/113

(Continued)

**FOREIGN PATENT DOCUMENTS**

CN 1307442 A 8/2001  
CN 1816228 A 8/2006

(Continued)

*Primary Examiner* — Tuan H Nguyen

(74) *Attorney, Agent, or Firm* — Bayramoglu Law Offices LLC

(57) **ABSTRACT**

The present invention discloses a transparent OLED device, which comprises a plurality of pixels, each pixel comprising an organic functional layer, a first transparent electrode and a second transparent electrode being disposed on both sides of the organic functional layer, a reflective electrode being disposed on one side of the organic functional layer, the area of the reflective electrode being less than that of the organic functional layer. With regard to the transparent OLED device, by providing a reflective electrode, a combination of a light-emitting device over a microdomain is combined with a transparent light-emitting device, such that the luminance on both sides of a transparent OLED device can be respectively adjusted to be the same or different as required. The present invention can be applied to the field of transparent illumination or display.

**14 Claims, 2 Drawing Sheets**

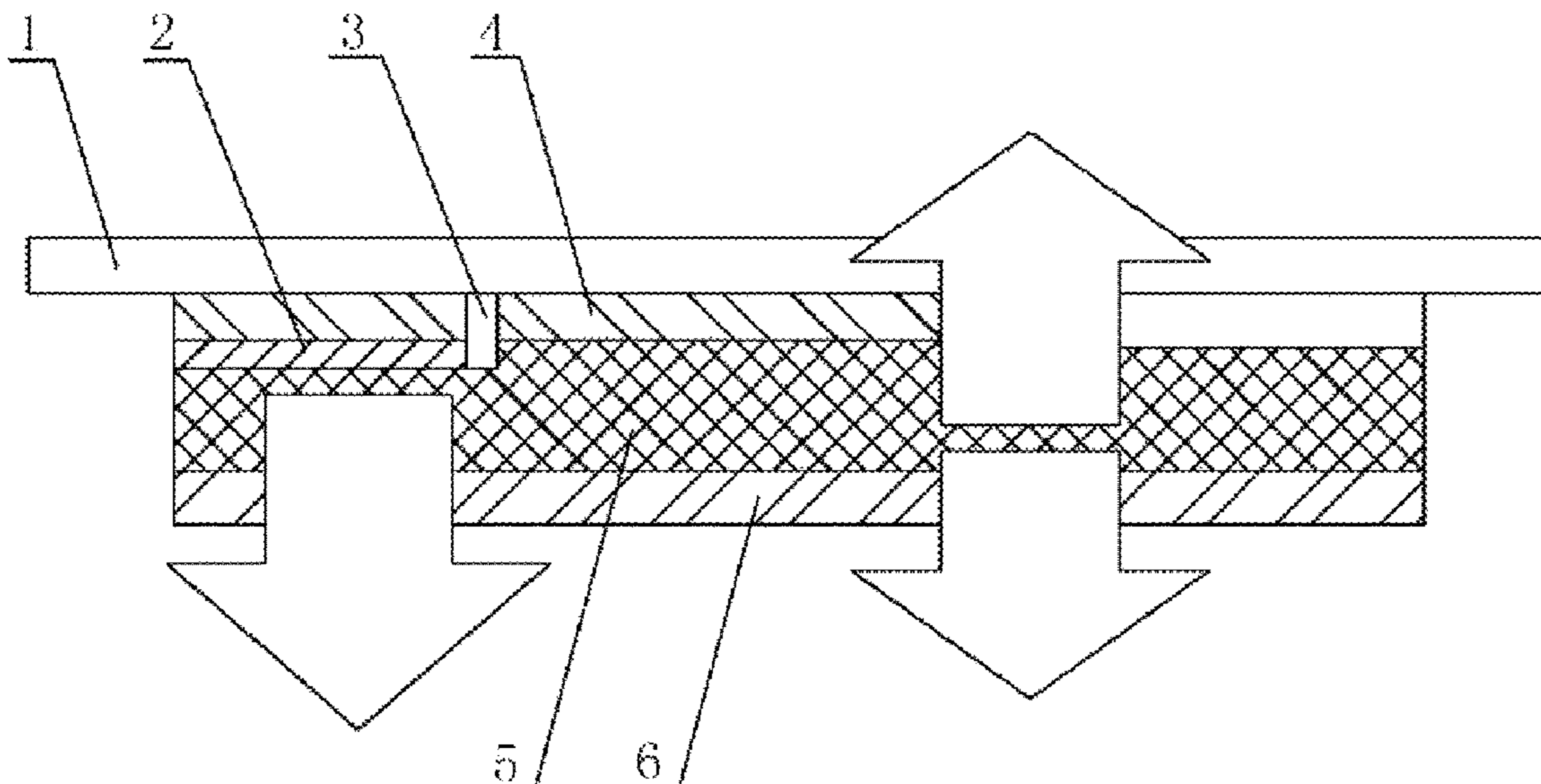

# US RE48,695 E

Page 2

(52) **U.S. Cl.**  
CPC ..... *H01L 51/5206* (2013.01); *H01L 51/5234*  
(2013.01); *H01L 51/5253* (2013.01); *H01L*  
*2251/5323* (2013.01)

(56) **References Cited**

U.S. PATENT DOCUMENTS

2003/0156240 A1\* 8/2003 Oda ..... G02F 1/133553  
349/113  
2003/0201716 A1 10/2003 Yamazaki et al.  
2005/0173693 A1\* 8/2005 Uchida ..... H01L 27/3211  
257/13  
2005/0230684 A1\* 10/2005 Seo ..... H01L 27/3248  
257/72  
2006/0097251 A1\* 5/2006 Kang ..... H01L 51/5271  
257/40  
2006/0138945 A1\* 6/2006 Wolk ..... H01L 27/3211  
313/506  
2007/0228399 A1\* 10/2007 Iwawaki ..... H01L 51/006  
257/89  
2008/0258609 A1\* 10/2008 Nakamura ..... H01L 51/5265  
313/504  
2009/0072709 A1\* 3/2009 Kobayashi ..... H01L 27/3206  
313/503  
2010/0090592 A1\* 4/2010 Shiobara ..... H01L 27/3211  
313/504  
2010/0237374 A1\* 9/2010 Chu ..... H01L 51/5271  
257/98  
2011/0240964 A1 10/2011 Ko et al.  
2011/0272675 A1 11/2011 Chung et al.  
2012/0074435 A1 3/2012 Ha et al.  
2015/0102306 A1 4/2015 Shi et al.

2015/0102309 A1 4/2015 Tsuzaki  
2015/0171375 A1\* 6/2015 Setz ..... H01L 51/5275  
257/40  
2016/0079286 A1\* 3/2016 Jin ..... H01L 29/66742  
257/71  
2016/0155977 A1\* 6/2016 Kim ..... H01L 51/5016  
257/40  
2016/0372712 A1\* 12/2016 Liao ..... H01L 51/5271  
2017/0062767 A1\* 3/2017 Bao ..... H01L 51/5056

FOREIGN PATENT DOCUMENTS

CN 101169910 A 4/2008  
CN 101373576 A 2/2009  
CN 102881695 A 1/2013  
CN 103345884 A 10/2013  
CN 103474448 A 12/2013  
CN 103715230 A 4/2014  
CN 103715369 A 4/2014  
JP 2006-140127 A 6/2006  
JP 2006-140151 A 6/2006  
JP 2011-228249 A 11/2011  
JP 2012-033307 A 2/2012  
JP 2012506604 A 3/2012  
JP 2012-142582 A 7/2012  
JP 2012-155320 A 8/2012  
JP 2012-226365 A 11/2012  
JP 2013-117719 A 6/2013  
KR 1020060042779 A 5/2006  
KR 10-2010-0105431 A 9/2010  
KR 1020110046564 A 5/2011  
TW 201246552 A 11/2012  
WO 2013190781 A1 12/2013

\* cited by examiner

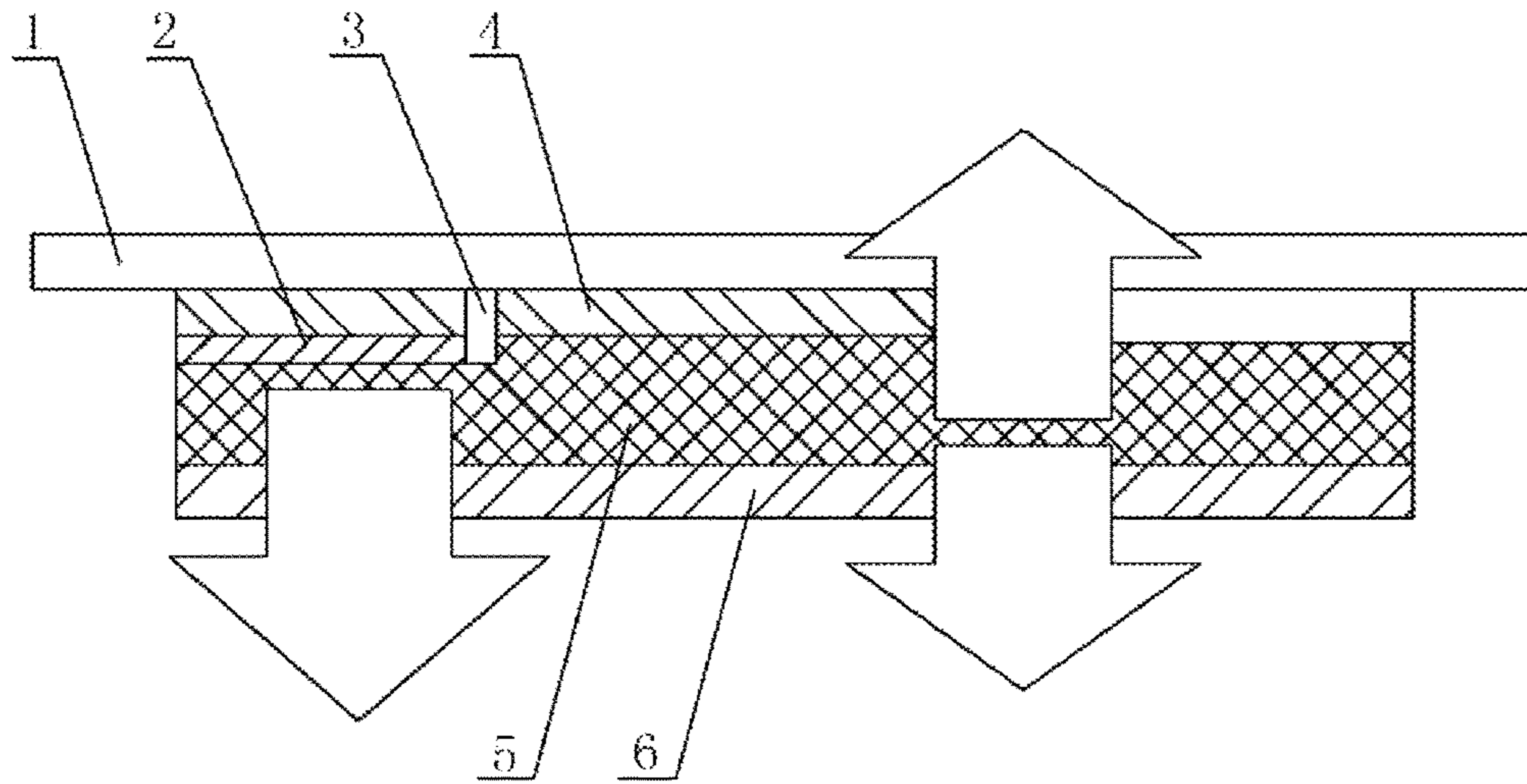

FIG. 1

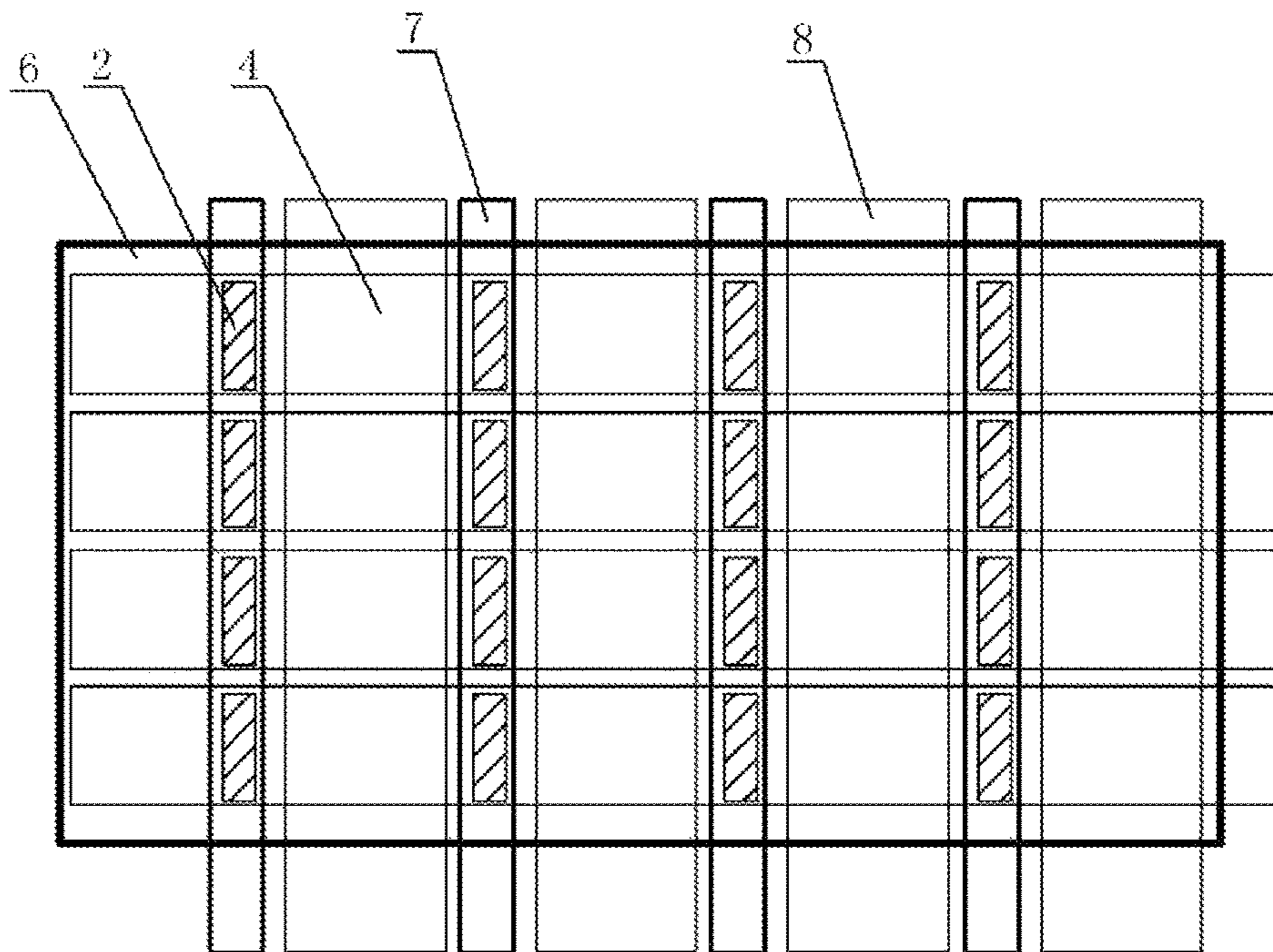

FIG. 2



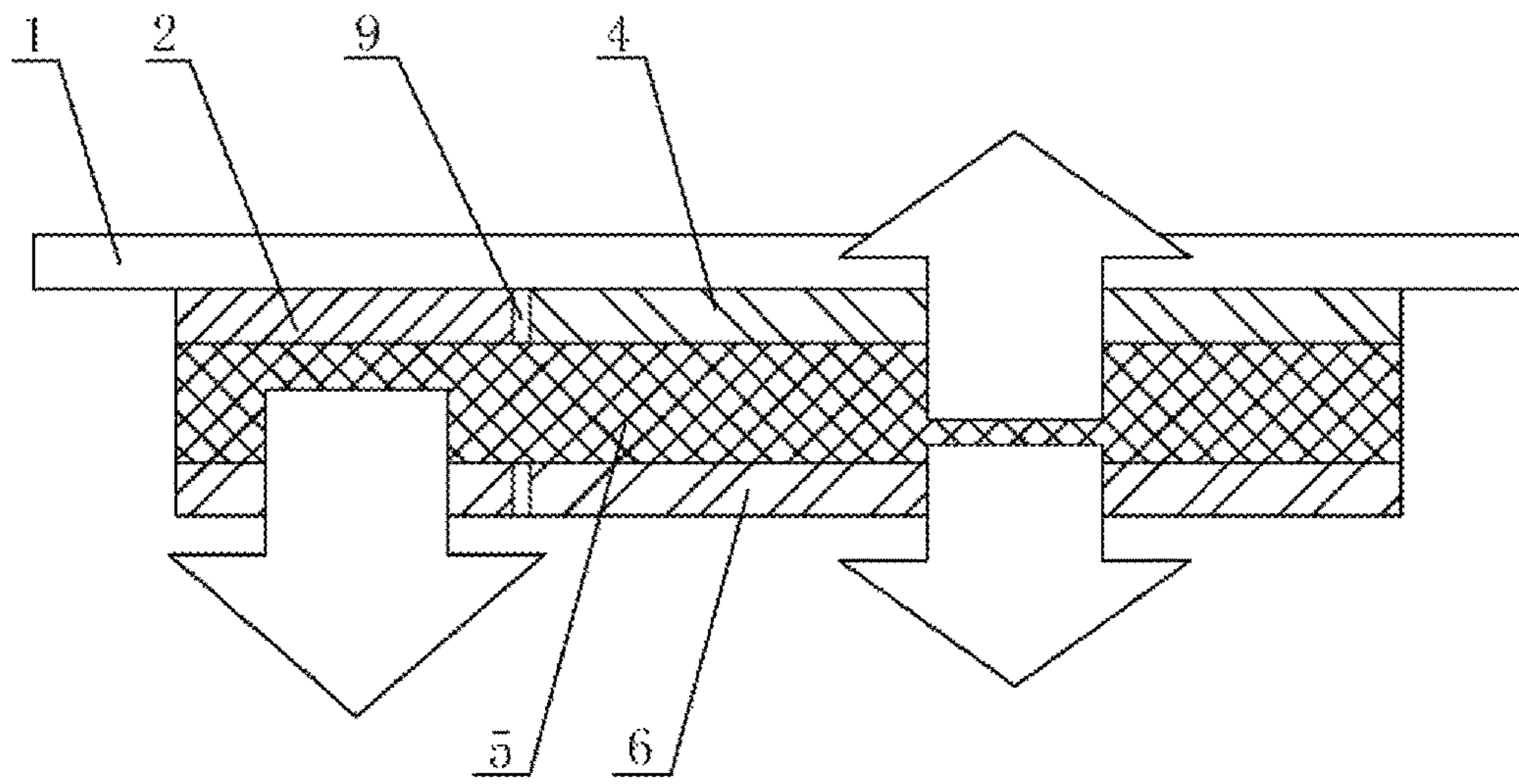

FIG. 3

## TRANSPARENT OLED DEVICE AND DISPLAY DEVICE EMPLOYING SAME

**Matter enclosed in heavy brackets [ ] appears in the original patent but forms no part of this reissue specification; matter printed in italics indicates the additions made by reissue; a claim printed with strikethrough indicates that the claim was canceled, disclaimed, or held invalid by a prior post-patent action or proceeding.**

### CROSS-REFERENCE TO RELATED APPLICATIONS

*This application is a re-issue of U.S. patent application Ser. No. 15/109,410, filed on Jun. 30, 2016, now U.S. Pat. No. 9,692,006 issued on Jun. 27, 2017, where U.S. patent application Ser. No. 15/109,410 is an application of National Stage Entry of PCT/CN2014/095335, filed on Dec. 29, 2014, and claims priority to Chinese Foreign Priority Document CN 201310749017 filed on Dec. 31, 2013.*

### TECHNICAL FIELD

The present invention relates to an organic light-emitting diode (OLED) device and in particular to a transparent OLED device and a display device using the transparent OLED device.

### BACKGROUND

OLED devices are active light-emitting devices. Compared with thin-film transistor LCDs (TFT-LCDs) in the existing mainstream flat panel display technology, OLEDs, due to their advantages such as high contrast, wide angle of view, low power consumption, thinner size and the like, are expected to become the flat panel display technology of the next generation, and are one of technologies that are highly concerned among the existing flat panel display technologies.

Due to the active light-emitting property of OLEDs, backlight is not required such that transparent display can be achieved. A transparent OLED display, with advantages of self-illumination and penetration of ambient light through the display screen, becomes a novel display technology in the future. However, in an existing transparent OLED device, both the anode and the cathode of the OLED device are prepared by using a transparent conductive layer. This results in the following defects:

1) inconsistent luminance of two light-emitting surfaces; and

2) incapable of individually adjusting the luminance of the two light-emitting surfaces.

### SUMMARY

#### Technical Problems

Technical problems to be solved by the present invention are to provide a transparent OLED device that can individually adjust light-emitting of two light-emitting surfaces and make the luminance of the two light-emitting surfaces consistent, and a display device that employs the transparent OLED device.

#### Solution to the Problems

To solve the aforementioned problems, the present invention provides a transparent OLED device including a plu-

rality of pixels, each pixel including an organic functional layer, a first transparent electrode and a second transparent electrode being disposed on both sides of the organic functional layer respectively, a reflective electrode being disposed on one side of the organic functional layer, the area of the reflective electrode being less than that of the organic functional layer.

Further, the reflective electrode is located between the first transparent electrode and the organic functional layer, and an insulating layer is disposed between the reflective electrode and the first transparent electrode.

Further, the area of the reflective electrode is 10% to 50% of the area of the organic functional layer.

Further, reflective electrodes between adjacent pixels in one direction are electrically connected, and the reflective electrodes are led out from pixels located at both ends and connected to a power supply.

Further, the reflective electrode is located on the same side as the first transparent electrode, and is disposed in parallel to the first transparent electrode; and a slit is formed between the reflective electrode and the first transparent electrode. Further, insulating material is filled in the slit.

Further, the second transparent electrode is divided into two portions, with one portion being disposed opposite to the reflective electrode and the other portion being disposed opposite to the first transparent electrode.

Further, the first transparent electrode is an anode, and the second transparent electrode is a cathode; or the first transparent electrode is a cathode, and second transparent electrode is an anode.

Further, the average light transmittance the first transparent electrode at a visible wavelength is 50% to 95%; and the average light transmittance of the second transparent electrode at a visible wavelength is 5% to 95%.

The present invention also provides an organic light-emitting display device including the aforementioned transparent OLED device.

The present invention achieves the following beneficial effects:

With regard to the transparent OLED device, by providing a reflective electrode, a light-emitting device over a micro-domain is combined with a transparent light-emitting device, such that the luminance on both sides of a transparent OLED device can be respectively adjusted to be the same or different as required. The present invention can be applied to the field of transparent illumination or display.

### BRIEF DESCRIPTION OF THE DRAWINGS

FIG. 1 is a schematic structural view of a transparent OLED device according to one embodiment of the present invention;

FIG. 2 is a schematic planar structural view illustrating connection of a plurality of pixels according to the present invention; and

FIG. 3 is a schematic structural view of a transparent OLED device according to another embodiment of the present invention.

### DETAILED DESCRIPTION

In order to make those skilled in the art better understand and practice the present invention, the present invention will be further described hereinafter in detail with reference to the accompanying drawings and specific embodiments, but the embodiments exemplified hereinafter are not intended to limit the present invention.



3

As shown in FIG. 1, in this embodiment, a transparent OLED device includes a plurality of pixels. The size of each pixel is not limited. However, generally, the size of a pixel should be less than the minimum resolution of human eyes having a corresponding distance from the screen. Each pixel includes an organic functional layer 5. The organic functional layer 5, which is the same as an organic functional layer in the existing technique, includes a hole injection layer, an organic light-emitting layer, an electron injection layer and the like, and will not be described repeatedly here. A first transparent electrode 4 and a second transparent electrode 6 are disposed on both sides of the organic functional layer 5 respectively, wherein a substrate 1 is on the outer side of the first transparent electrode 4. A reflective electrode 2 is disposed on one side of the organic functional layer 5, and the area of the reflective electrode 2 is less than that of the organic functional layer 5. In this embodiment, the reflective electrode 2 is located between the first transparent electrode 4 and the organic functional layer 5, and an insulating layer 3 is disposed between the reflective electrode 2 and the first transparent electrode 4 in order to prevent a short circuit between the two.

When the transparent OLED device of the present invention is in use, by powering on the reflective electrode 2 and the second transparent electrode 6, the transparent OLED device may be controlled to emit light towards the second transparent electrode 6; and by powering on the first transparent electrode 4 and the second transparent electrode 6, the double-sided light-emitting or display of the transparent OLED device may be achieved. In addition, if the reflective electrode 2, the first transparent electrode 4 and the second transparent electrode 6 are powered on simultaneously, but are subjected to a different current or voltage, it is possible to adjust the double-sided light-emitting luminance. In addition, by setting the color of an organic functional layer corresponding to the reflective electrode 2 in a different color from that of an organic functional layer corresponding to the first transparent electrode 4, the display color may be adjusted by the reflective electrode 2.

In the present invention, the area of the reflective electrode is preferably 10% to 50% of the area of the organic functional layer. The effect of adjustment will not be significant when the area of the reflective electrode is too small, while the transparency of the OLED device will be influenced when the area of the reflective electrode is too large.

Manufacture of the transparent OLED device of this embodiment includes the following steps:

preparing a first transparent electrode 4 on a transparent substrate 1;

preparing a reflective electrode layer on the first transparent electrode 4;

etching a portion of the reflective electrode layer by processes such as coating, exposing, developing and etching, with the remaining portion forming a reflective electrode 2;

etching an edge of the reflective electrode 2, such that a portion of the reflective electrode 2 connected to the first transparent electrode 4 is disconnected;

filling the part where the reflective electrode 2 is disconnected from the first transparent electrode 4 with an insulating material to form an insulating layer 3;

evaporating an organic functional layer 5 over the first transparent electrode 4 and the reflective electrode 2; and

preparing a second transparent electrode 6 over the organic functional layer 5 to obtain a transparent OLED device of this embodiment.

4

Nevertheless, what is described above is only a preferred scheme for manufacturing a transparent OLED device of this embodiment, and the actual manufacturing process is not limited thereto.

In this embodiment, since the reflective electrode 2 is disposed between the first transparent electrode 4 and the second transparent electrode 6, to connect the reflective electrode 2 of each pixel to the power supply, the reflective electrodes 2 between adjacent pixels in one direction may be electrically connected, and the serially-connected reflective electrodes 2 are led out from pixels at both ends and connected to the power supply. As in the embodiment shown in FIG. 2, in this embodiment, the reflective electrodes 2 between pixels of each row in the longitudinal direction, i.e., in a same row, are connected in series, and are led out from pixels at both extreme ends to form a reflective lead-out electrode 7, and the reflective lead-out electrode 7 is connected to an external power supply to supply power to the reflective electrode 2. Since the area of the first transparent electrode 4 in this embodiment completely covers the organic functional layer 5 of a pixel, the first transparent electrodes 4 between pixels in a same row may be connected in series and then led out from both ends to form a first transparent lead-out electrode 8 in the same manner as the reflective electrode; or, the first transparent electrodes 4 of all pixels may be electrically connected and then led out from the surrounding.

As in another embodiment of the transparent OLED device of the present invention shown in FIG. 3, in this embodiment, the reflective electrode 2 is located on a same side as the first transparent electrode 4, and is disposed in parallel to the first transparent electrode 4. To prevent a short circuit between the reflective electrode 2 and the first transparent electrode 4, a slit 9 may be formed between the reflective electrode 2 and the first transparent electrode 4. Further preferably, an insulating material may be filled in the slit 9 to enhance the insulating property. However, the second transparent electrode 6 in this embodiment is divided into two portions, with one portion being disposed opposite to the reflective electrode 2 and the other portion being disposed opposite to the first transparent electrode 4. To achieve the insulating effect, a slit is also formed between the two portions of the second transparent electrode 6. Furthermore, insulating material may be also filled in the slit. Of course, in other embodiments, the second transparent electrode 6 may be an entirety which completely covers the organic functional layer 5.

In the above-mentioned embodiments, the first transparent electrode 4 and the second transparent electrode 6 are a cathode and an anode of an OLED device respectively, and may be exchangeable in position. That is, the first transparent electrode 4 may be an anode and the second transparent electrode 6 may be a cathode; or, the first transparent electrode 4 may be a cathode and the second transparent electrode 6 may be an anode, without imposing any influence on the implementation of the present invention. The average light transmittance of the first transparent electrode 4 at a visible wavelength is 5% to 95%; and the average light transmittance of the second transparent electrode at a visible wavelength is 5% to 95%. When the average light transmittance of the second transparent electrode 6 at a visible wavelength is 5% to 50%, a large portion of light emitted by the OLED device is output from the side of the first transparent electrode 4, and a small portion thereof is output from the side of the second transparent electrode 6, thereby



5

forming a double-sided display. Light emitted by the OLED device may be output from both sides, thereby forming a transparent OLED device.

The aforementioned embodiments are only preferred embodiments merely used for describing the present invention in detail, and the protection scope of the present invention is not limited thereto. For a person skilled in the art, various replacements or improvements may be made on the basis of the present invention, and those replacements or improvements shall be regarded as falling into the protection scope of the present invention. The protection scope of the present invention is subject to the appended claims.

What is claimed is:

1. A transparent OLED device, comprising:  
a plurality of pixels, each pixel including:  
an organic functional layer *having two sides*,  
a first transparent electrode, and  
a second transparent electrode **[being]** disposed on **[both]**  
*the two sides* of the organic functional layer respec-  
tively, *and*  
**[wherein]** a reflective electrode **[is]** disposed on one **[side]**  
*of the sides* of the organic functional layer, **[and]** the  
area of the reflective electrode **[is]** *being* less than that  
of the organic functional layer, *and*  
*wherein*  
*the reflective electrode is located between the first trans-*  
*parent electrode and the organic functional layer, and*  
*an insulating layer is disposed between the reflective*  
*electrode and the first transparent electrode, or*  
*the reflective electrode is located on a same side as the*  
*first transparent electrode, and is disposed in parallel*  
*to the first transparent electrode; and a slit is formed*  
*between the reflective electrode and the first transpar-*  
*ent electrode.*

**[2.** The transparent OLED device according to claim 1,  
wherein the reflective electrode is located between the first  
transparent electrode and the organic functional layer, and an  
insulating layer is disposed between the reflective electrode  
and the first transparent electrode.]

**3.** The transparent OLED device according to claim 1,  
wherein the area of the reflective electrode is 10% to 50% of  
the area of the organic functional layer.

**4.** The transparent OLED device according to claim 1,  
wherein reflective electrodes between adjacent pixels in one  
direction are electrically connected, and the reflective elec-  
trodes are led out from pixels located at both ends and  
connected to a power supply.

**[5.** The transparent OLED device according to claim 1,  
wherein the reflective electrode is located on a same side as

6

the first transparent electrode, and is disposed in parallel to  
the first transparent electrode; and a slit is formed between  
the reflective electrode and the first transparent electrode.]

**6.** The transparent OLED device according to claim **[5]** 1,  
wherein the slit is filled with an insulating material.

**7.** The transparent OLED device according to claim **[5]** 1,  
wherein the second transparent electrode is divided into two  
portions, with one portion being disposed opposite to the  
reflective electrode and the other portion being disposed  
opposite to the first transparent electrode.

**8.** The transparent OLED device according to claim 1,  
wherein the first transparent electrode is an anode, and the  
second transparent electrode is a cathode; or the first trans-  
parent electrode is a cathode, and the second transparent  
electrode is an anode.

**9.** The transparent OLED device according to claim 1,  
wherein:

the average light transmittance of the first transparent  
electrode at a visible wavelength is 50% to 95%; and  
the average light transmittance of the second transparent  
electrode at a visible wavelength is 5% to 95%.

**10.** An organic light emitting display device comprising a  
transparent OLED device according to claim 1.

**[11.** The transparent OLED device according to claim 2,  
wherein reflective electrodes between adjacent pixels in one  
direction are electrically connected, and the reflective elec-  
trodes are led out from pixels located at both ends and  
connected to a power supply.]

**[12.** An organic light emitting display device comprising  
a transparent OLED device according to claim 2.]

**13.** An organic light emitting display device comprising a  
transparent OLED device according to claim 3.

**14.** An organic light emitting display device comprising a  
transparent OLED device according to claim 4.

**[15.** An organic light emitting display device comprising  
a transparent OLED device according to claim 5.]

**16.** An organic light emitting display device comprising a  
transparent OLED device according to claim 6.

**17.** An organic light emitting display device comprising a  
transparent OLED device according to claim 7.

**18.** An organic light emitting display device comprising a  
transparent OLED device according to claim 8.

**19.** An organic light emitting display device comprising a  
transparent OLED device according to claim 9.

**[20.** An organic light emitting display device comprising  
a transparent OLED device according to claim 11.]

\* \* \* \* \*