



US00RE48645E

(19) **United States**
(12) **Reissued Patent**
Edsall et al.

(10) **Patent Number:** **US RE48,645 E**
(45) **Date of Reissued Patent:** **Jul. 13, 2021**

(54) **EXPORTING REAL TIME NETWORK TRAFFIC LATENCY AND BUFFER OCCUPANCY**

(58) **Field of Classification Search**
None
See application file for complete search history.

(71) Applicant: **Cisco Technology, Inc.**, San Jose, CA (US)

(56) **References Cited**

(72) Inventors: **Thomas J. Edsall**, Los Gatos, CA (US); **Yue J. Yang**, San Jose, CA (US); **Wei-Jen Huang**, Burlingame, CA (US); **Chih-Tsung Huang**, Burlingame, CA (US)

U.S. PATENT DOCUMENTS

6,246,684 B1 6/2001 Chapman et al.
6,690,646 B1 * 2/2004 Fichou H04L 41/0896
370/231

(Continued)

(73) Assignee: **CISCO TECHNOLOGY, INC.**, San Jose, CA (US)

FOREIGN PATENT DOCUMENTS

GB 2477640 A 8/2011
WO 2008/097001 A1 8/2008

(21) Appl. No.: **16/400,122**

OTHER PUBLICATIONS

(22) Filed: **May 1, 2019**

International Search Report and Written Opinion in counterpart International Application No. PCT/US2013/059180, dated Nov. 28, 2013, 10 pages.

(Continued)

Related U.S. Patent Documents

Reissue of:

(64) Patent No.: **9,641,407**
Issued: **May 2, 2017**
Appl. No.: **15/285,603**
Filed: **Oct. 5, 2016**

Primary Examiner — John M Hotaling

(74) *Attorney, Agent, or Firm* — Edell, Shapiro & Finnan, LLC

U.S. Applications:

(63) Continuation of application No. 14/707,139, filed on May 8, 2015, now Pat. No. 9,509,622, which is a (Continued)

(57) **ABSTRACT**

Techniques are presented herein to facilitate the monitoring of occupancy of a buffer in a network device. Packets are received at a network device. Information is captured describing occupancy of the buffer caused by packet flow through the buffer in the network device. Analytics packets are generated containing the information. The analytics packets from the network device for retrieval of the information contained therein for analysis, replay of buffer occupancy, etc.

(51) **Int. Cl.**
H04L 12/26 (2006.01)
H04L 12/851 (2013.01)
H04L 12/835 (2013.01)

(52) **U.S. Cl.**
CPC **H04L 43/045** (2013.01); **H04L 43/08** (2013.01); **H04L 43/0882** (2013.01); (Continued)

39 Claims, 6 Drawing Sheets

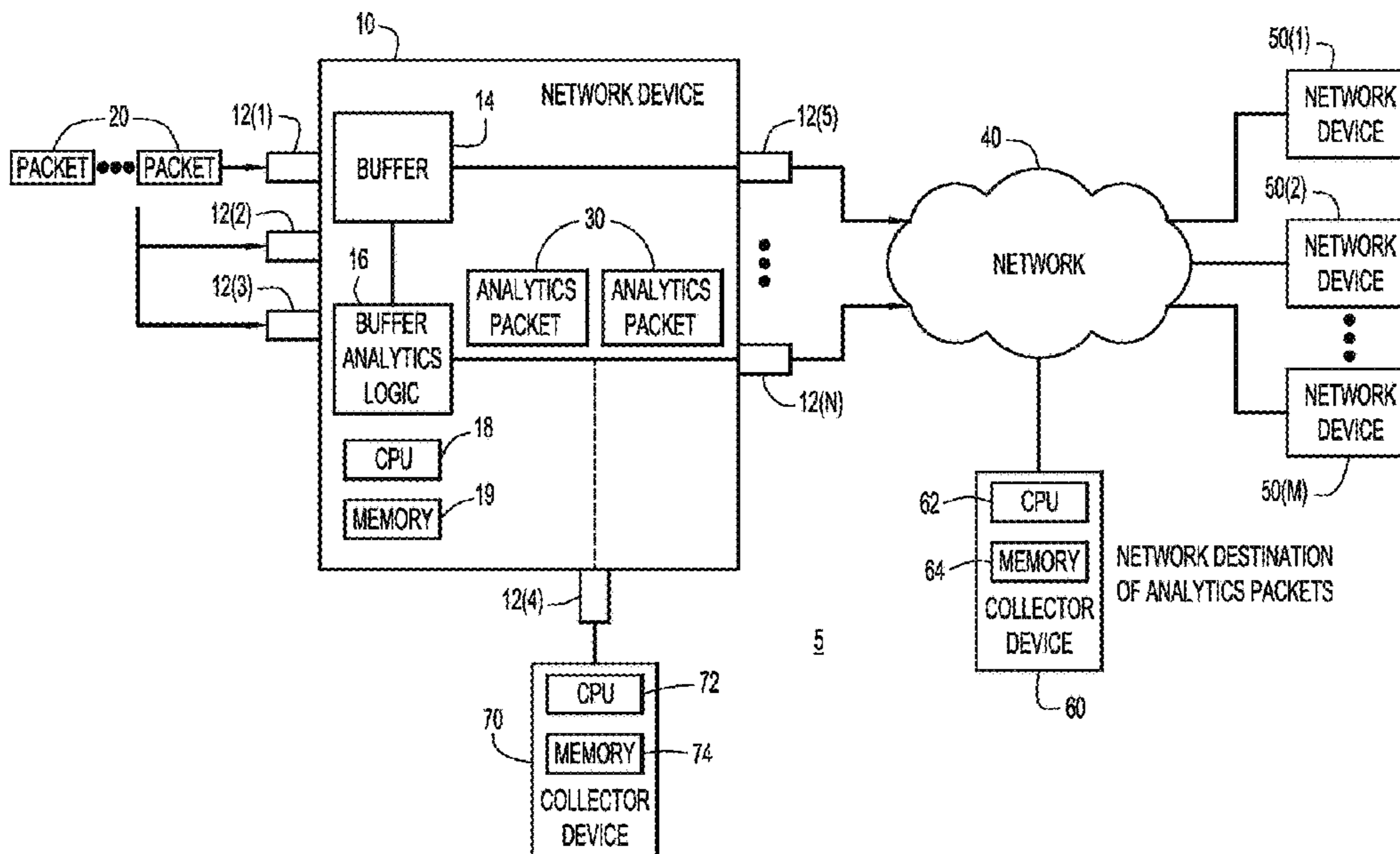

US RE48,645 E

Page 2

Related U.S. Application Data

continuation of application No. 13/708,265, filed on Dec. 7, 2012, now Pat. No. 9,077,619.

(60) Provisional application No. 61/702,320, filed on Sep. 18, 2012.

(52) **U.S. Cl.**
CPC *H04L 43/10* (2013.01); *H04L 47/24* (2013.01); *H04L 47/30* (2013.01)

(56) References Cited

U.S. PATENT DOCUMENTS

6,853,623	B2	2/2005	Nederveen et al.	
6,892,237	B1	5/2005	Gai et al.	
6,990,202	B2	1/2006	Wee et al.	
7,106,731	B1	9/2006	Lin et al.	
7,395,332	B2	7/2008	Gai et al.	
7,474,666	B2	1/2009	Kloth et al.	
7,656,818	B1	2/2010	Baroudi et al.	
7,792,130	B2	9/2010	Fischer	
7,830,793	B2	11/2010	Gai et al.	
7,899,048	B1	3/2011	Walker et al.	
7,961,621	B2	6/2011	Bergamasco et al.	
7,969,971	B2	6/2011	Gai et al.	
8,116,307	B1	2/2012	Thesayi et al.	
8,208,389	B2	6/2012	Alaria et al.	
8,274,905	B2	9/2012	Edwards et al.	
8,605,588	B2	12/2013	Sankaran et al.	
8,640,036	B2	1/2014	Pignataro et al.	
8,681,806	B2	3/2014	Bucknell et al.	
8,767,551	B2*	7/2014	Goldfarb H04L 63/1416	370/235
2003/0007456	A1*	1/2003	Gupta H04L 1/0002	370/232

2003/0231596	A1	12/2003	Hong	
2005/0182850	A1*	8/2005	Kohno H04L 1/0009	709/236
2005/0240745	A1	10/2005	Iyer et al.	
2006/0062209	A1	3/2006	Riley	
2006/0253900	A1	11/2006	Paddon et al.	
2006/0268847	A1	11/2006	Halbraich et al.	
2008/0285463	A1*	11/2008	Oran H04L 65/80	370/241
2009/0034416	A1	2/2009	Baron et al.	
2009/0041011	A1	2/2009	Sheppard	
2009/0100040	A1	4/2009	Sheppard et al.	
2009/0171474	A1	7/2009	Birze et al.	
2010/0054152	A1	3/2010	Foschiano et al.	
2010/0154033	A1	6/2010	Oulai	
2010/0287297	A1	11/2010	Lefebvre	
2012/0093505	A1	4/2012	Yeap et al.	
2012/0215909	A1*	8/2012	Goldfarb H04L 63/306	709/224
2013/0155858	A1*	6/2013	Chen H04L 47/10	370/235
2013/0194923	A1*	8/2013	Basso H04L 47/56	370/232
2015/0244637	A1	8/2015	Edsall et al.	

OTHER PUBLICATIONS

English translation of First Office Action and Search Report in counterpart Chinese Application No. 201380048250.6, dated Nov. 21, 2016, 10 pages.

English translation of Second Office Action in counterpart Chinese Application No. 201380048250.6, dated May 2, 2017, 3 pages.

First Examination Report in counterpart Indian Application No. 444/MUMNP/2015, dated May 24, 2019, 6 pages.

Cisco Systems, Inc., "Cisco Nexus 3000 Series NX-OS Release Notes, Release 5.0(3)U2(1)," pp. 1-12, Aug. 31, 2011.

* cited by examiner

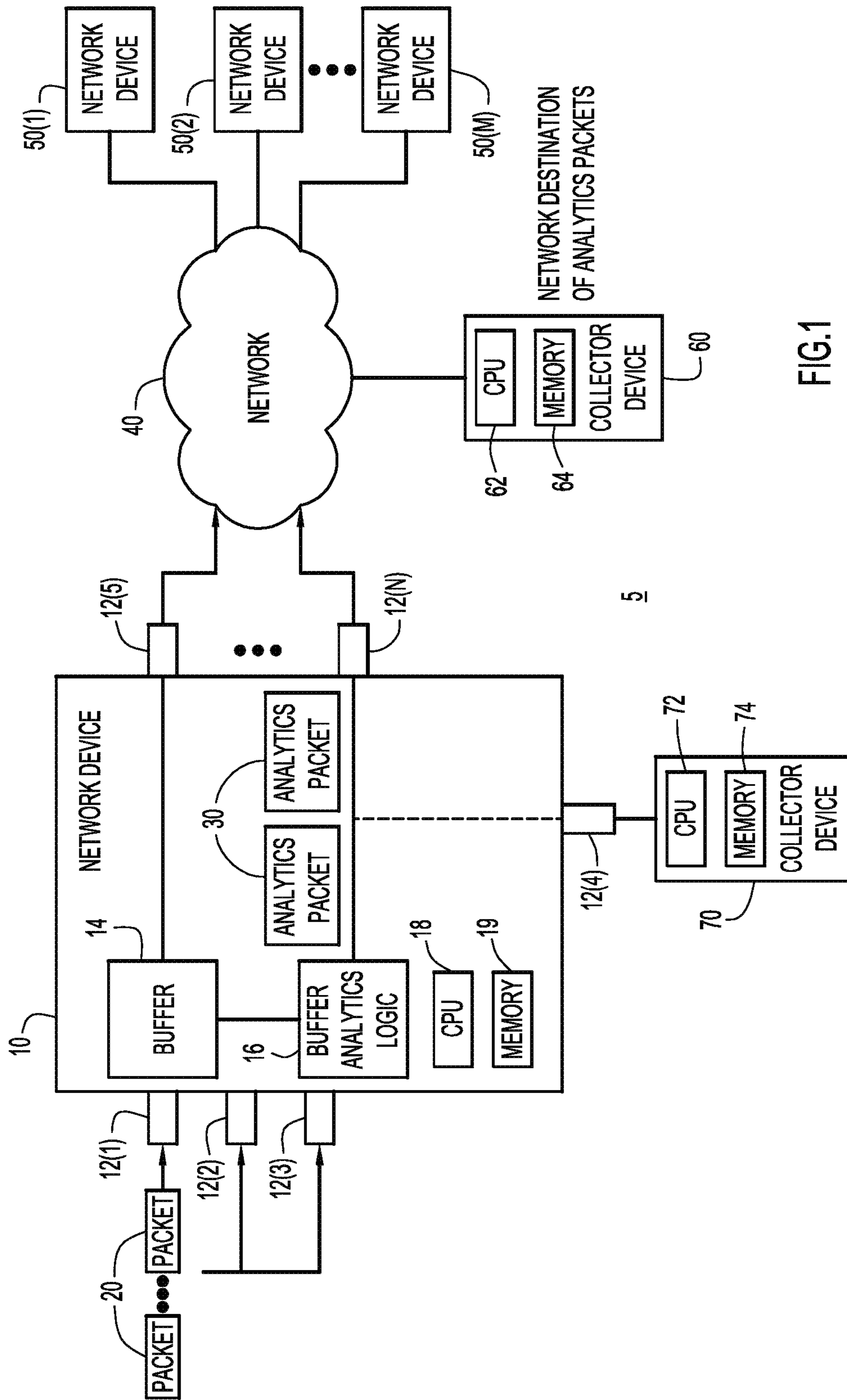
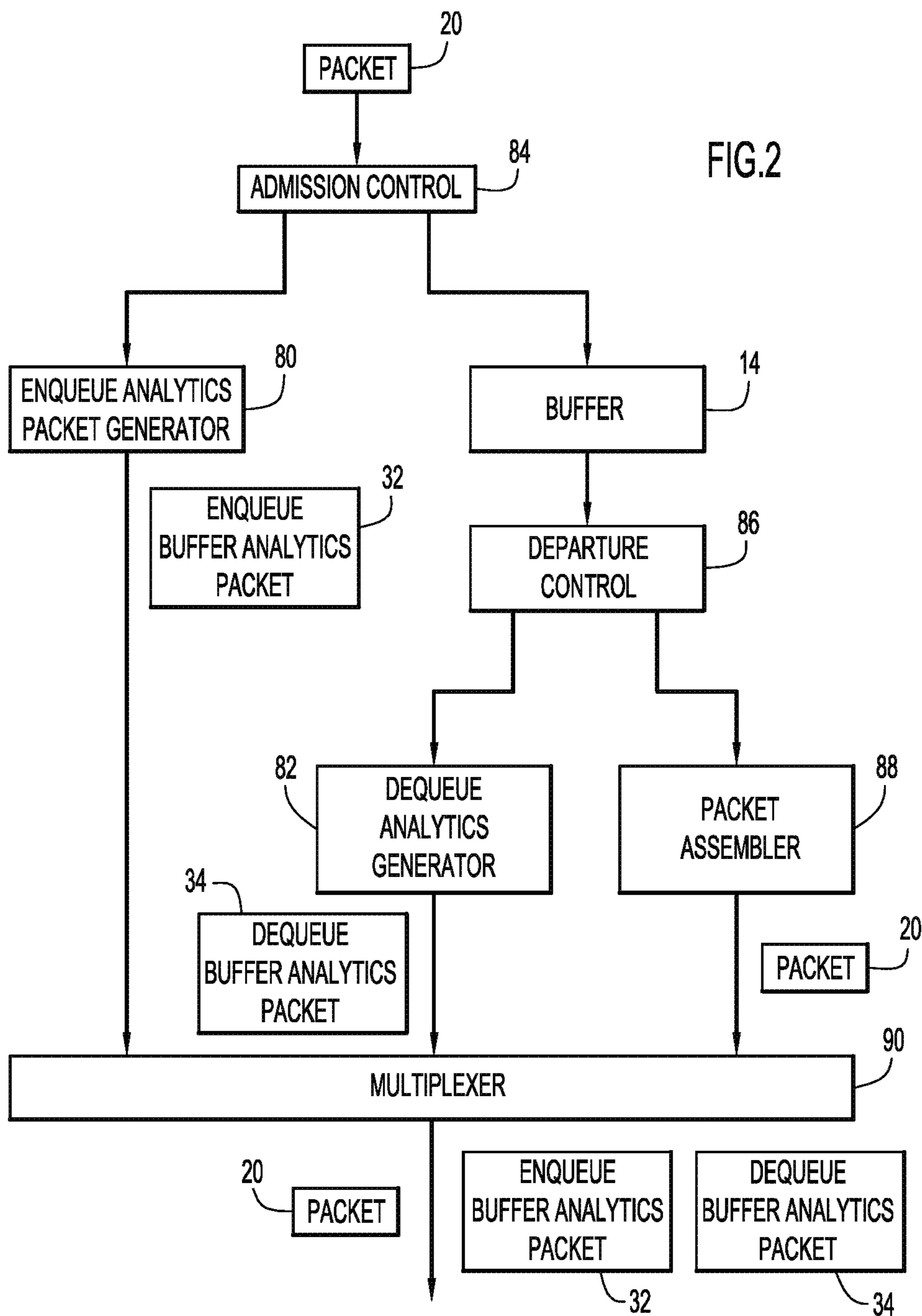

FIG.1



32/34

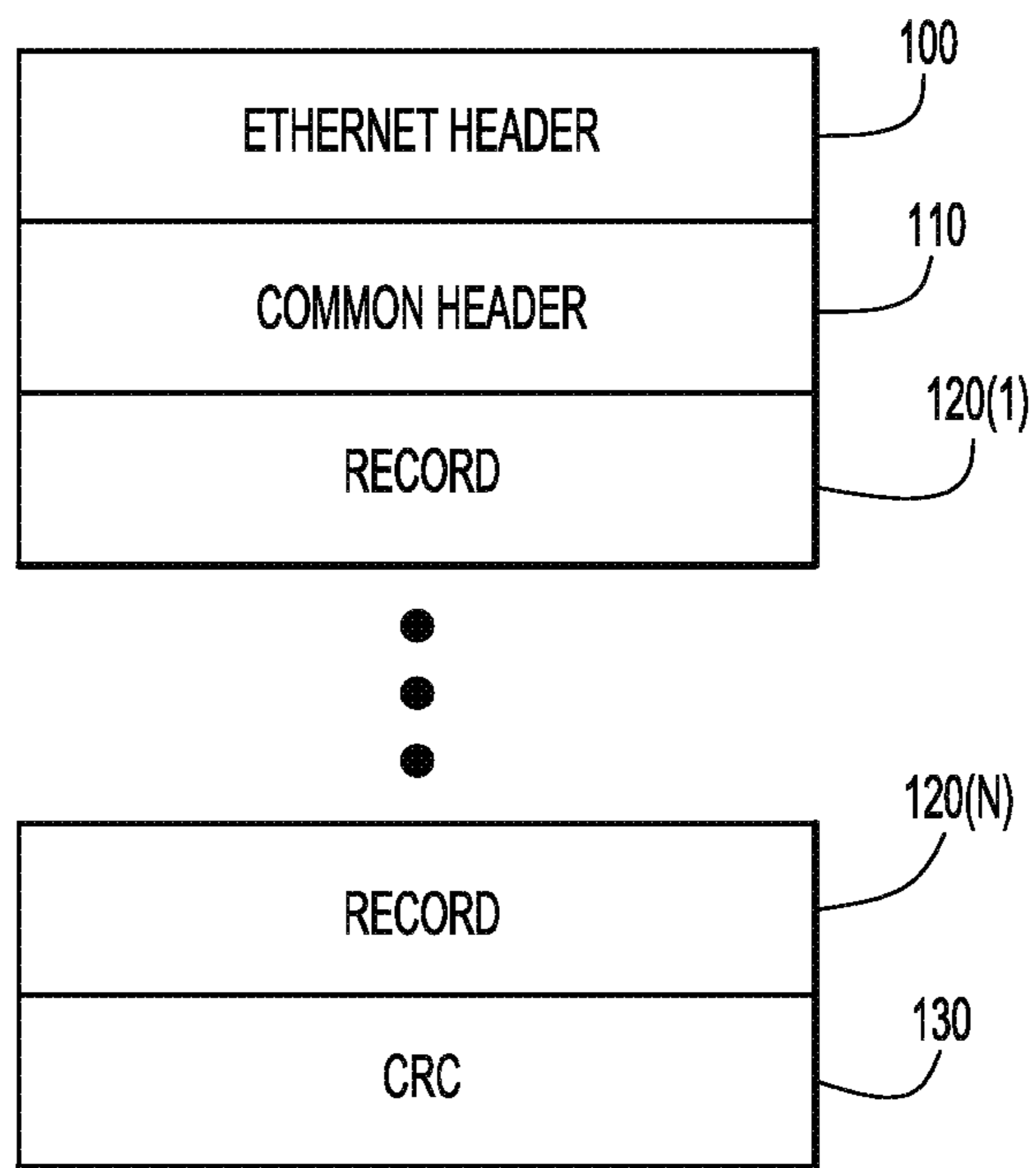

FIG.3

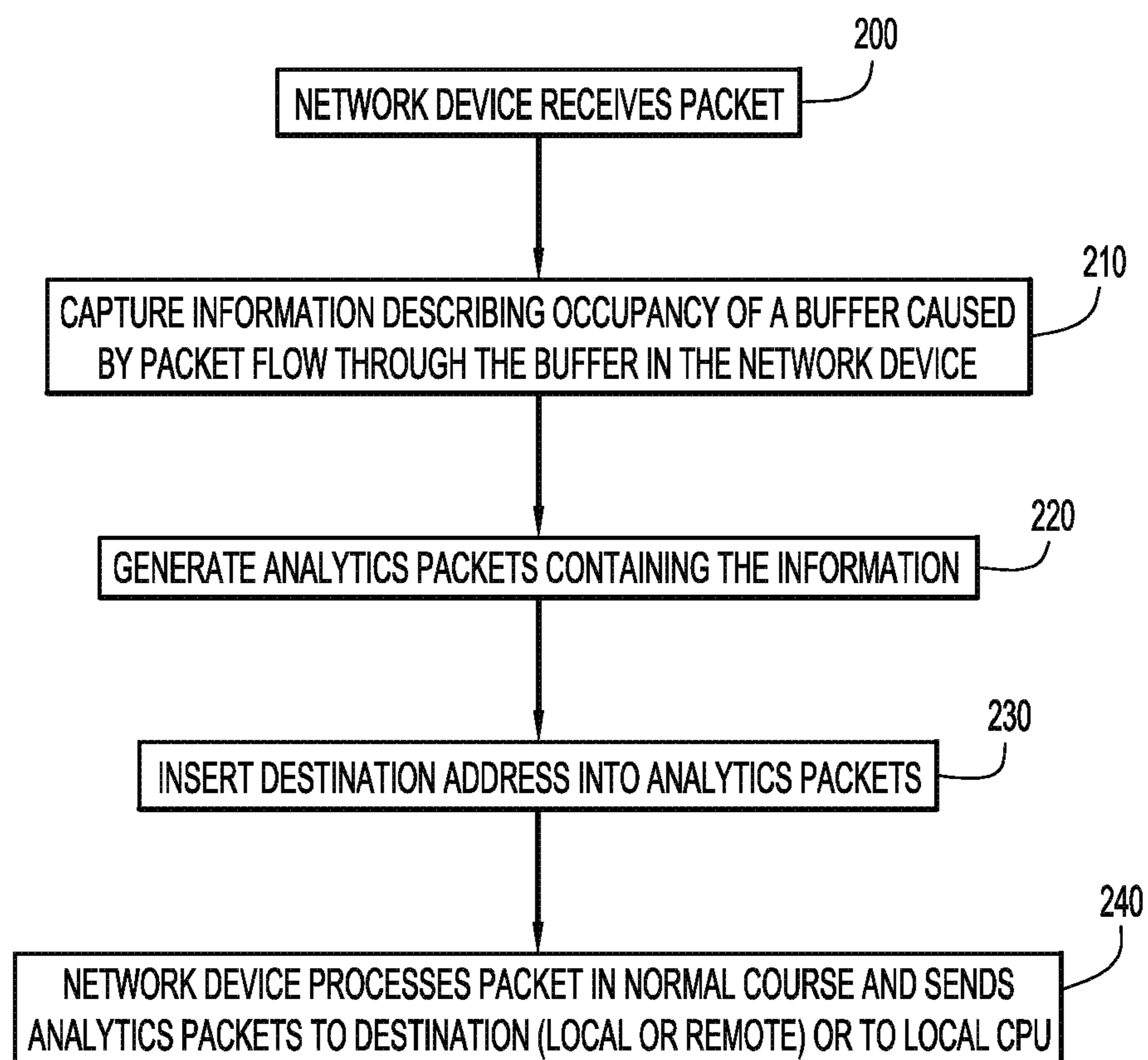

FIG.4

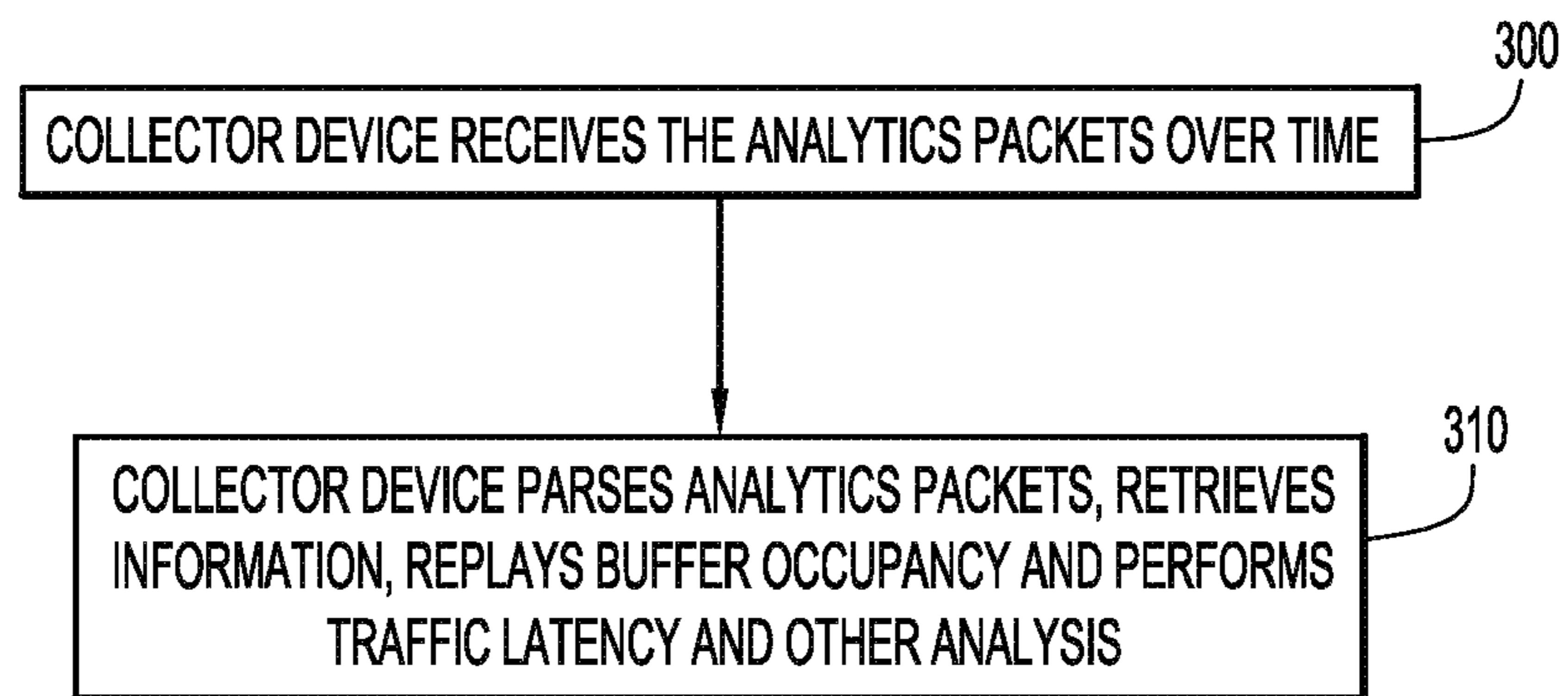

FIG.5

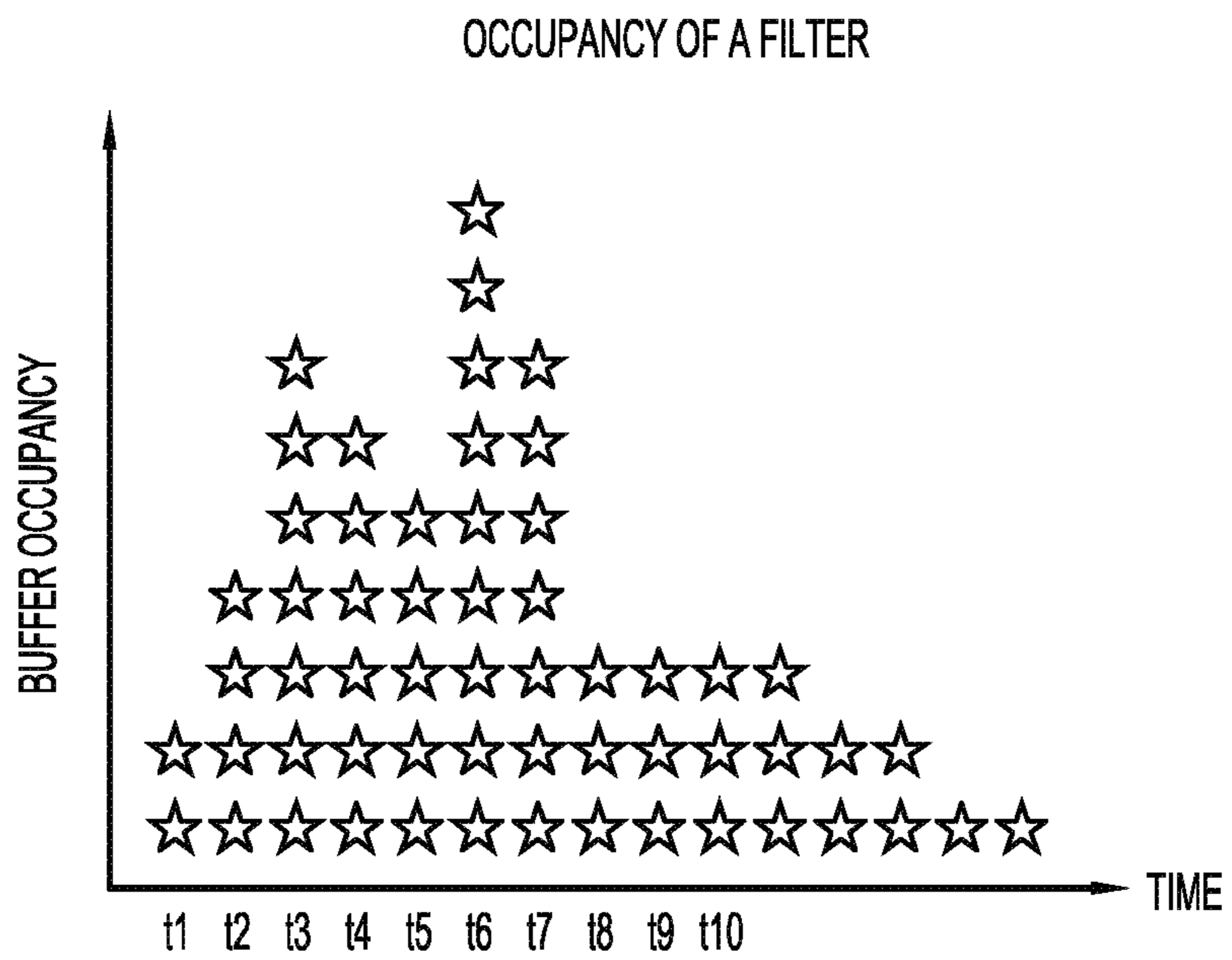

FIG.6

1

EXPORTING REAL TIME NETWORK TRAFFIC LATENCY AND BUFFER OCCUPANCY

Matter enclosed in heavy brackets [] appears in the original patent but forms no part of this reissue specification; matter printed in italics indicates the additions made by reissue; a claim printed with strikethrough indicates that the claim was canceled, disclaimed, or held invalid by a prior post-patent action or proceeding.

RELATED APPLICATIONS

This application is a continuation of U.S. application Ser. No. 14/707,139, filed May 8, 2015, which in turn is a continuation of U.S. application Ser. No. 13/708,265, filed Dec. 7, 2012, now U.S. Pat. No. 9,077,619, which in turn claims priority to U.S. Provisional Application No. 61/702,320, filed Sep. 18, 2012, entitled "Exporting Real Time Network Traffic Latency and Buffer Occupancy." The entirety of these applications is incorporated herein by reference.

TECHNICAL FIELD

The present disclosure relates generally to analysis of occupancy of a buffer in a network device.

BACKGROUND

In a computer network, data is transmitted from a source to a destination in the form of packets that generally pass through one or more network devices (e.g., switches, routers, firewalls, etc.). During the transmission, certain errors may arise that result in, for example, redundant data being added to the original data, dropped packets, etc. Massively Scalable Data Center and Cloud Computing systems are putting more traffic load on network equipment such that over-provisioned networks are no longer possible. Monitoring of a buffer in a network device is useful to gain knowledge for network administration, analysis, and performance.

BRIEF DESCRIPTION OF THE DRAWINGS

FIG. 1 is a diagram illustrating a network device configured to generate buffer analytics packets based on occupancy of a buffer in the network device.

FIG. 2 is a block diagram illustrating one example implementation of the buffer analytics logic.

FIG. 3 is a diagram that generally illustrates a format of a buffer analytics packet.

FIG. 4 is a flow chart depicting operations in a network device to generate and output buffer analytics packets.

FIG. 5 is a flow chart depicting operations in a device that receives and retrieves information from the buffer analytics packets.

FIG. 6 is a diagram illustrating an example of playback of buffer occupancy from buffer analytics packets.

DESCRIPTION OF EXAMPLE EMBODIMENTS

Overview

Techniques are presented herein to facilitate the monitoring of occupancy of a buffer in a network device. Packets are

2

received at a network device. Information is captured describing occupancy of the buffer caused by packet flow through the buffer in the network device. Analytics packets are generated containing the information. The analytics packets from the network device for retrieval of the information contained therein for analysis, replay of buffer occupancy, etc.

Example Embodiments

Complete network visibility into buffer occupancy and the ability to replay occupancy via export and post processing is important since network disruptions (e.g., microbursts) can occur at any time. Furthermore, the ability to replay buffer occupancy allows for effective diagnosis of network issues to provide corrective actions. Existing solutions such as port mirroring (i.e., Switched Port Analyzer (SPAN)) do not provide visibility of buffer occupancy. As such, presented herein are techniques for monitoring and replaying buffer occupancy.

Referring now to FIG. 1, a diagram is shown of a network environment 5 in which a network device 10 is provided that is configured to generate buffer analytics packets based on occupancy of a buffer the network device 10. The network device 10 comprises a plurality of ports 12(1)-12(N), any of which can serve as an ingress port or egress port at any time. The network device includes a buffer 14, buffer analytics logic 16, a central processing unit (CPU) 18 and memory 19. It should be understood that there are other components of the network device 10, such as a switch fabric or application specific integrated circuit (ASIC), and the buffer 14 may reside the switch fabric. There are typically numerous buffers in the network device 10, but for simplicity only one is shown in FIG. 1. It should be understood that the techniques presented herein are useful for each of a plurality of buffers in a network device. The buffer analytics logic 14 may be implemented in hardware by digital logic gates (and embedded in the switch fabric) or by software stored in memory 19 and executed by CPU 18.

Packets 20 arrive at the network device 10 via any of the ports 12(1)-12(N). FIG. 1 shows an example where packets are arriving at ports 12(1), 12(2) and 12(3). The network device 10 is coupled to a network 40, e.g., a local area network or wide area network (the Internet), via ports 12(5)-12(N) to ultimately communicate with any one or more of the network devices 50(1)-50(M).

Generally, the buffer analytics logic 16 captures information describing occupancy of the buffer 14 caused by packet flow through the buffer in the network device 10, and generates buffer analytics packets 30 containing the information. As will become apparent from the description below in connection with FIG. 2, there are two types of buffer analytics packets: enqueue buffer analytics packets and dequeue buffer analytics packets. The buffer analytics packets 30 are then output from the network device 10 at a programmable time schedule (or based of packet size) in any one of several ways to allow for replay of the occupancy of the buffer.

First, the network device 10 may insert into buffer analytics packets 30 an address for a destination of the buffer analytics packet, e.g., address for any device connected to the network 40, such as collector device 60 having a CPU 62 and memory 64. The network device 10 sends the analytics packet 30 via network 40 to the destination collector device 60, which may be at any location, local or remote from network device 10.

Second, the network device **10** may output the analytics packet **30** to a dedicated port, e.g., port **12(4)** of the network device **10** to which a collector device **70** is connected. The dedicated analytics port **12(4)** can participate in port channel or fixed port distribution to expand bandwidth to a single or multiple monitor ports. The collector device **70**, since it is connected directly to port **12(4)**, is usually local to the network device **10**. The collector device **70** includes a CPU **72** and memory **74**.

Third, the analytics packets **30** may be output to the onboard CPU **18** and memory **19** in the network device **10**, such that CPU **18** and memory **19** also serve as a collector device. In any of these scenarios, the CPUs **18**, **62** and **72** may replay and analyze the occupancy of the buffer **14** based on software instructions stored in its associated memory **19**, **64** and **74**, respectively. Moreover, the analytics packets are stored in the memory **19**, **64** and **74** for the associated CPU **18**, **62** and **72**, respectively.

The network device **10** can be any network device now known or hereinafter developed, including a switch, router, gateway, a software stack on a host device, virtual network interface cards (VNICs) virtual switches, physical network interface cards (including those that support virtualization).

Memory **19**, **64** and **74** may comprise read only memory (ROM), random access memory (RAM), magnetic disk storage media devices, optical storage media devices, flash memory devices, electrical, optical, or other physical/tangible memory storage devices. Thus, in general, the memory **19**, **64** and **74** may comprise one or more tangible (non-transitory) computer readable storage media (e.g., a memory device) encoded with software comprising computer executable instructions and when the software is executed (by the associated CPU) it is operable to perform the operations described herein.

Reference is now made to FIG. **2** for a more detailed description of the buffer analytics logic **16**. FIG. **2** shows that the buffer analytics logic **16** comprises an enqueue analytics packet generator **80** and a dequeue analytics packet generator **82**. In addition, there are an admission control block **84**, a departure control block **86**, a packet assembler **88** and a multiplexer **90**. The admission control block **84** and departure control block **86** are commonly found in a network device and are hardware (or software) blocks used to make processing decisions, such as a drop, scheduling, rate limiting, policing, shaping, etc.

The enqueue analytics packet generator **80** is configured to generate an analytics packet, called an enqueue buffer analytics packet shown at reference numeral **32**, that describes/summarizes a packet being enqueued into buffer **14**. Similarly, the dequeue analytics packet generator **82** is configured to generate an analytics packet, called a dequeue buffer analytics packet shown at reference numeral **34**, that describes/summarizes a packet being dequeued from buffer **14**. The packet assembler **88** assembles a packet **20** ready out from the buffer **14** for output from the network device.

The enqueue analytics packet generator **80** captures, for a packet enqueued to buffer **14**, information describing one or more of identification of ingress port of arrival of the packet at the network device, Layer 2 source address and destination address, Layer 3 source address and destination address, Layer 4 source address and destination address, class of service, and timestamp of arrival at the ingress port. Similarly, the dequeue analytics packet generator **82** captures, for a packet dequeued from the buffer **14**, information describing one or more of identification of egress port for departure of the packet from the network device, Layer 2 source

address and destination address, Layer 3 source address and destination address, and timestamp of departure from the egress port.

The enqueue buffer analytics packet **32** generated by the enqueue analytics packet generator **80**, dequeue buffer analytics packet **34** generated by the dequeue analytics packet generator **82**, and packet **20** output by the packet assembler **88**, are all supplied to a corresponding input of the multiplexer **90**. The multiplexer **90** selectively outputs, at any given time, either a packet **20**, an enqueue buffer analytics packet **32** or a dequeue buffer analytics packet **34**. Priority is given to output of a packet **20** in order to maintain proper flow of network traffic through the network device **10**. Trigger for output of an analytics packet may be based on time (according to a schedule) or size of a packet enqueued to the buffer or dequeued from the buffer.

Reference is now made to FIG. **3**. FIG. **3** shows an example format of an enqueue buffer analytics packet **32** or dequeue buffer analytics packet **34**. As explained above, an enqueue buffer analytics packet **32** summarizes a packet that is being enqueued to a buffer and a dequeue buffer analytics packet **34** summarizes a packet that is being dequeued from the buffer. These analytics packets, when accumulated over time for packets that pass through the buffer, allow for playback of occupancy characteristics of the buffer and traffic flow of packets through the buffer. As shown in FIG. **3**, an enqueue buffer analytics packet **32** and a dequeue buffer analytics packet **34** includes an Ethernet Header field **100**, a Common Header field **110**, one or more Records fields **120(1)-120(N)** and a cyclic redundancy check (CRC) field **130**.

The Ethernet header field **110** is field that is used to encapsulate the destination address of the analytics packet, e.g., to direct the analytics packet to a destination, i.e., a local or remote collector device (as indicated in FIG. **1**), including to the CPU of the network device itself. To this end, the Ethernet header field **110** includes information, such as media access control (MAC) destination address/source address (DA/SA), optional IEEE 802.1q virtual local area network (VLAN) routing information, an optional Internet Protocol (IP) header including an IP SA and IP DA. Again, the Ethernet header field **110** contains information used to route the buffer analytics packet to its desired destination.

The common header field **110** contains information captured from the header of a packet that has been enqueued to or dequeued (as the case may be) from the buffer. Thus, the common header field summarizes the header of a packet that is enqueued to and dequeued from the buffer in the network device. For example, the common header field includes information for a common header version (to allow for backward/future compatibility), timescale information representing the timescale of the enqueued or dequeued packet, a timestamp of the packet arrival and/or departure to/from the buffer to allow for replay, a record number to allow a collector to determine how many, if any records, have been lost in between the current analytics packet and the last received analytics packet, and one or more user defined fields such as class of service, type of service, etc.

The record field **120** contains data for an enqueued or dequeued packet that a user configures the buffer analytics logic to capture. Examples of data that may be include in a record field includes:

Format version to indicate a format version of the record field for backward/future compatibility.

L2 Header Fields (MAC SA/DA) or compressed versions (i.e. last 24 bits) and priority

5

L3 Header (IP SA/DA) or compressed versions (i.e. last 16 bits) and priority and protocol type

L4 Header (TCP/UDP SA/DA)

User defined fields, including one or more of:

Input/output port

Drop—an indication of whether the packet was dropped.

Queue id—identifier of the queue (unicast or multicast) to which the packet is associated

Queue length—length of the queue to which the packet is associated.

Packet length—overall length of size of the packet.

Timestamp (absolute or relative to common header from protocols such as

Precision Time Protocol (PTP) or Network Time Protocol (NTP))

Programmable bytes—any user configurable one or more bytes of the payload of a packet

Internally specific fields such as logical interface mapped from table with keys such as {ingress/egress port, vlan}

Last record—to indicate that this is last record field in the analytics packet.

Thus, to summarize, the record field **120** for an analytics packet contains information about an enqueued packet or dequeued packet to describe buffer occupancy characteristics such as overall buffer occupancy, buffer occupancy based on packet priority, unicast queue length, multicast queue length; packet properties such as drop, port mirrored, load balanced, bridged or routed, and packet length; and packet error properties such as Cyclic Redundancy Check (CRC), and various error protocols such as Runt, Giant, and Jabber. More specifically, for a packet enqueued to the buffer, information is included in the record field describing one or more of identification of ingress port of arrival of the packet at the network device, Layer 2 source address and destination address, Layer 3 source address and destination address, Layer 4 source address and destination address, class of service, and timestamp of arrival at the ingress port. Similarly, for a packet dequeued from the buffer, information is included in the record field describing one or more of identification of egress port for departure of the packet from the network device, Layer 2 source address and destination address, Layer 3 source address and destination address, and timestamp of departure from the egress port. Other examples of data captured into user defined fields include an indication of a packet being rate limited, shaped, policed as well as any programmable bytes of the packet including payload.

The size of the analytics packet (Ethernet header field, common header field and records) may be the Maximum Transmit Unit (MTU), a switch specific analytics MTU, determined using a time-based method (e.g., analytics packet generated and transmitted at predetermined times), determined based on a selected number of packets, or by other techniques.

Reference is now made to FIG. 4. FIG. 4 provides a flow chart that depicts the high level operations performed in a network device in generating and outputting analytics packets. At **200**, a network device receives a packet. At **210**, the network device captures information describing occupancy of a buffer caused by packet flow through the buffer in the network device. At **220**, an analytics packet is generated for each packet that is enqueued to and/or dequeued from the buffer. At **230**, a destination address is inserted into the analytics packet. At **240**, the network device processes the packet in the normal course, and outputs an analytics packet to its destination (local or remote network destination) or to a local CPU of the network device. The capturing, generat-

6

ing, and outputting operations are triggered to be performed based on at least one of time and size of enqueued packet or dequeued packet.

FIG. 5 illustrates a high level flow chart depicting the operations performed at a destination of the analytics packets. At **300**, a collector device receives the analytics packets over time. At **310**, the collector device parses the analytics packets to retrieve information in the individual records as well as the common header, and uses this information to replay buffer occupancy, perform traffic latency and perform other analysis.

FIG. 6 shows an example of how a replay of buffer occupancy, subject to certain filtering criteria, may be made. In FIG. 6, a “*” represents data that has been stored into buffer and lack of “*” represents absence or removal of data from the buffer.

By generating and exporting analytics packets that summarize properties of packets enqueued to and dequeued from a buffer in a network device, a replay of the buffer may be achieved using specific pieces of information that are of interest to network administrators and application developers. Recording each of these categories would require enormous bandwidth if a complete enqueued or dequeued packet is captured.

In summary, presented herein are techniques that enable a time-based complete replay of the buffer occupancy with resolution determined by a sampling period. These techniques provide visibility of traffic flows received by network devices. The information provided can be used by network administrators to gain insight into their specific network traffic, such as per-packet latency, buffer occupancy, and possible congestion sources. This information can lead to better allocation and provisioning of network resources, reduced congestion, and higher overall throughput. By parsing and aggregating relevant characteristics from each packet according to the techniques presented herein, bandwidth requirements associated with network monitoring are greatly reduced. As such, these techniques assist in reducing the amount of data exported for analysis.

The above description is intended by way of example only.

What is claimed is:

1. A method comprising:

at a collector device configured to be in communication with a network device operating in a network:

receiving analytics packets containing information describing occupancy of a buffer of the network device caused by packet flow through the buffer in the network device, each analytics packet including a record summarizing characteristics of a packet enqueued in the buffer or of a packet dequeued from the buffer; and

replaying the information pertaining to the occupancy of the buffer over time based on the analytics packets, by generating data for visually presenting to a user the information pertaining to the occupancy of the buffer over time.

2. The method of claim 1, wherein replaying is based on one or more filtering criteria.

3. The method of claim 1, wherein the information describes at least one of: identification of ingress port of arrival of a packet at the network device, Layer 2 source address and destination address, Layer 3 source address and destination address, Layer 4 source address and destination address, class of service, or timestamp of arrival of a packet at the ingress port.

4. The method of claim 1, wherein the information describes at least one of: identification of egress port for departure of a packet from the network device, Layer 2 source address and destination address, Layer 3 source address and destination address, or timestamp of departure of a packet from the egress port.

5. The method of claim 1, wherein the analytics packets include enqueue analytics packets and dequeue analytics packets, the enqueue analytics packets including information describing properties associated with a packet being enqueued to the buffer in the network device and the dequeue analytics packets including information describing properties associated with a packet being dequeued from the buffer in the network device.

6. The method of claim 1, wherein the information describes buffer occupancy characteristics of the buffer including at least one of: overall buffer occupancy, buffer occupancy based on packet priority, unicast queue length or multicast queue length.

7. The method of claim 1, wherein the information describes packet processing properties for packets processed by the network device including at least one of: drop, port mirrored, load balanced, bridged or routed, or packet length.

8. The method of claim 1, wherein the information describes packet processing properties for packets corresponding to user defined parameters for one or more of: rate limited, shaped, policed or any programmable bytes of the packet including payload.

9. An apparatus comprising:

a memory;

a processor coupled to the memory and configured to be in communication with a network device operating in a network, and configured to:

receive analytics packets containing information describing occupancy of a buffer of the network device caused by packet flow through the buffer in the network device, each analytics packet including a record summarizing characteristics of a packet enqueued in the buffer or of a packet dequeued from the buffer; and

replay the information pertaining to the occupancy of the buffer over time based on the analytics packets, by generating data for visually presenting to a user the information pertaining to the occupancy of the buffer over time.

10. The apparatus of claim 9, wherein the processor is configured to generate data to replay the information based on one or more filtering criteria.

11. The apparatus of claim 9, wherein the information describes at least one of: identification of ingress port of arrival of a packet at the network device, Layer 2 source address and destination address, Layer 3 source address and destination address, Layer 4 source address and destination address, class of service, or timestamp of arrival of a packet at the ingress port.

12. The apparatus of claim 9, wherein the analytics packets include enqueue analytics packets and dequeue analytics packets, the enqueue analytics packets including information describing properties associated with a packet being enqueued to the buffer in the network device and the dequeue analytics packets including information describing properties associated with a packet being dequeued from the buffer in the network device.

13. The apparatus of claim 9, wherein the information describes buffer occupancy characteristics of the buffer

including at least one of: overall buffer occupancy, buffer occupancy based on packet priority, unicast queue length or multicast queue length.

14. The apparatus of claim 9, wherein the information describes packet processing properties for packets processed by the network device including at least one of: drop, port mirrored, load balanced, bridged or routed, or packet length.

15. The apparatus of claim 9, wherein the information describes packet processing properties for packets corresponding to user defined parameters for one or more of: rate limited, shaped, policed or any programmable bytes of the packet including payload.

16. A non-transitory computer readable tangible storage media encoded with instructions that, when executed by a processor of a collector device in communication with a network device operating in the network, cause the processor to:

receive analytics packets containing information describing occupancy of a buffer of the network device caused by packet flow through the buffer in the network device, each analytics packet including a record summarizing characteristics of a packet enqueued in the buffer or of a packet dequeued from the buffer; and
replay the information pertaining to the occupancy of the buffer over time based on the analytics packets, by generating data for visually presenting to a user the information pertaining to the occupancy of the buffer over time.

17. The non-transitory computer readable tangible storage media of claim 16, further comprising instructions to generate data to replay the information based on one or more filtering criteria.

18. The non-transitory computer readable tangible storage media of claim 16, wherein the information describes at least one of: identification of ingress port of arrival of a packet at the network device, Layer 2 source address and destination address, Layer 3 source address and destination address, Layer 4 source address and destination address, class of service, or timestamp of arrival of a packet at the ingress port.

19. The non-transitory computer readable tangible storage media of claim 16, wherein the analytics packets include enqueue analytics packets and dequeue analytics packets, the enqueue analytics packets including information describing properties associated with a packet being enqueued to the buffer in the network device and the dequeue analytics packets including information describing properties associated with a packet being dequeued from the buffer in the network device.

20. The non-transitory computer readable tangible storage media of claim 16, wherein the information describing buffer occupancy characteristics of the buffer including at least one of: overall buffer occupancy, buffer occupancy based on packet priority, unicast queue length or multicast queue length.

21. A network device, comprising:

a plurality of ingress ports and a plurality of egress ports;
a buffer to temporarily store one or more packets received by the network device through one of the ingress ports;
and

analytics logic comprising digital logic gates and/or software that provide information associated with a first packet from the one or more packets, wherein the information comprises an indication of an ingress port of arrival of the one or more packets, a timestamp representing a time of capturing the one or more

- packets at the ingress port, a device identifier, and a packet error properties field;
 wherein the analytics logic generates a second packet including the information and sends the first packet to one of the plurality of egress ports.
22. The network device of claim 21, wherein the second packet is transmitted on an egress port different from the first packet.
23. The network device of claim 21, wherein the analytics logic further performs admission control or departure control.
24. The network device of claim 23, wherein the departure control includes one of dropping, scheduling rate limiting, policing, or shaping with respect to one or more packets sent out an egress port.
25. The network device of claim 23, wherein the admission control includes one of dropping, scheduling, rate limiting, policing, or shaping with respect to packets arriving at an ingress port.
26. The network device of claim 22, further comprising a collector device, wherein latency analysis is performed by the collector device on a packet flow associated with the first packet through analysis of the second packet.
27. A method for analyzing packets, comprising:
 receiving a plurality of packets from a plurality of ingress ports;
 temporarily storing one or more received packets in a buffer of a network device;
 analyzing a first packet from the one or more received packets to generate an indication of an ingress port of the first packet, a timestamp representing a time of reception of the first packet at the ingress port, a device identifier associated with the first packet, and a packet error properties field;
 generating a second packet including information from the first packet as well as the indication of the ingress port, the timestamp, the device identifier, and the packet error properties field; and
 sending the first packet out a first egress port.
28. The method of claim 27, wherein the method further comprises sending the second packet out a second egress port, different than the first egress port.
29. The method of claim 27, further comprising performing admission control or departure control.
30. The method of claim 29, wherein the departure control includes one of dropping, scheduling, rate limiting, policing, or shaping with respect to one or more packets sent out an egress port.

31. The method of claim 29, wherein the admission control includes one of dropping, scheduling, rate limiting, policing, or shaping with respect to packets arriving at an ingress port.
32. The method of claim 27, wherein the second packet contains information included in the first packet.
33. The method of claim 27, wherein the second packet includes one or more user-defined fields.
34. A non-transitory computer readable medium storing instructions that, when executed, cause a logic circuit to:
 receive a plurality of packets from a plurality of ingress ports;
 temporarily store one or more received packets in a buffer of a network device;
 analyze a first packet from the one or more received packets to generate an indication of an ingress port of the first packet, a timestamp representing a time of reception of the first packet at the ingress port, a device identifier associated with the first packet, and a packet error properties field;
 generate a second packet including information from the first packet as well as the indication of the ingress port, the timestamp, the device identifier, and the packet error properties field; and
 send the first packet out a first egress port.
35. The non-transitory computer readable medium of claim 34, wherein the instructions further cause the logic circuit to send the second packet out a second egress port, different than the first egress port.
36. The non-transitory computer readable medium of claim 34, wherein the instructions further cause the logic circuit to generate the packet error properties field and include it in the second packet.
37. The non-transitory computer readable medium of claim 34, wherein the instructions further cause the logic circuit to generate information identifying a particular network device and include it in the second packet as the device identifier.
38. The non-transitory computer readable medium of claim 34, wherein the instructions further cause the logic circuit to perform admission control including one of dropping, scheduling, rate limiting, policing, or shaping with respect to packets arriving at an ingress port.
39. The non-transitory computer readable medium of claim 34, wherein the instructions further cause the logic circuit to perform departure control including one of dropping, scheduling, rate limiting, policing, or shaping with respect to one or more packets sent out an egress port.