



US00RE48535E

(19) **United States**
(12) **Reissued Patent**
Mumby et al.

(10) **Patent Number:** **US RE48,535 E**
(45) **Date of Reissued Patent:** **Apr. 27, 2021**

(54) **WOUND DRESSING AND METHOD OF TREATMENT**

(71) Applicant: **Smith & Nephew PLC**, Watford (GB)

(72) Inventors: **Ella Lynn Mumby**, Hull (GB); **Helene Anne Lecomte**, York (GB)

(73) Assignee: **Smith & Nephew PLC**, Watford (GB)

(21) Appl. No.: **16/553,059**

(22) Filed: **Aug. 27, 2019**

Related U.S. Patent Documents

Reissue of:

(64) Patent No.: **10,039,673**
Issued: **Aug. 7, 2018**
Appl. No.: **15/220,204**
Filed: **Jul. 26, 2016**

U.S. Applications:

(62) Division of application No. 14/232,607, filed as application No. PCT/GB2012/000587 on Jul. 12, 2012, now Pat. No. 9,877,872.

(30) **Foreign Application Priority Data**

Jul. 14, 2011 (GB) 1112084
Jun. 22, 2012 (GB) 1211171

(51) **Int. Cl.**
A61M 27/00 (2006.01)
A61M 1/00 (2006.01)
(Continued)

(52) **U.S. Cl.**
CPC .. **A61F 13/00055** (2013.01); **A61F 13/00029** (2013.01); **A61F 13/00059** (2013.01);
(Continued)

(58) **Field of Classification Search**
CPC A61F 13/00055; A61F 13/00029; A61F 13/00059; A61F 13/00063;
(Continued)

(56) **References Cited**

U.S. PATENT DOCUMENTS

730,062 A 6/1903 Widmer
1,052,274 A * 2/1913 Purdy A61F 13/0203
604/307

(Continued)

FOREIGN PATENT DOCUMENTS

CN 101002707 A 7/2007
EP 0 053 936 6/1982

(Continued)

OTHER PUBLICATIONS

Allevyn Educational Booklet, Smith & Nephew Medical Ltd, Apr. 2014.

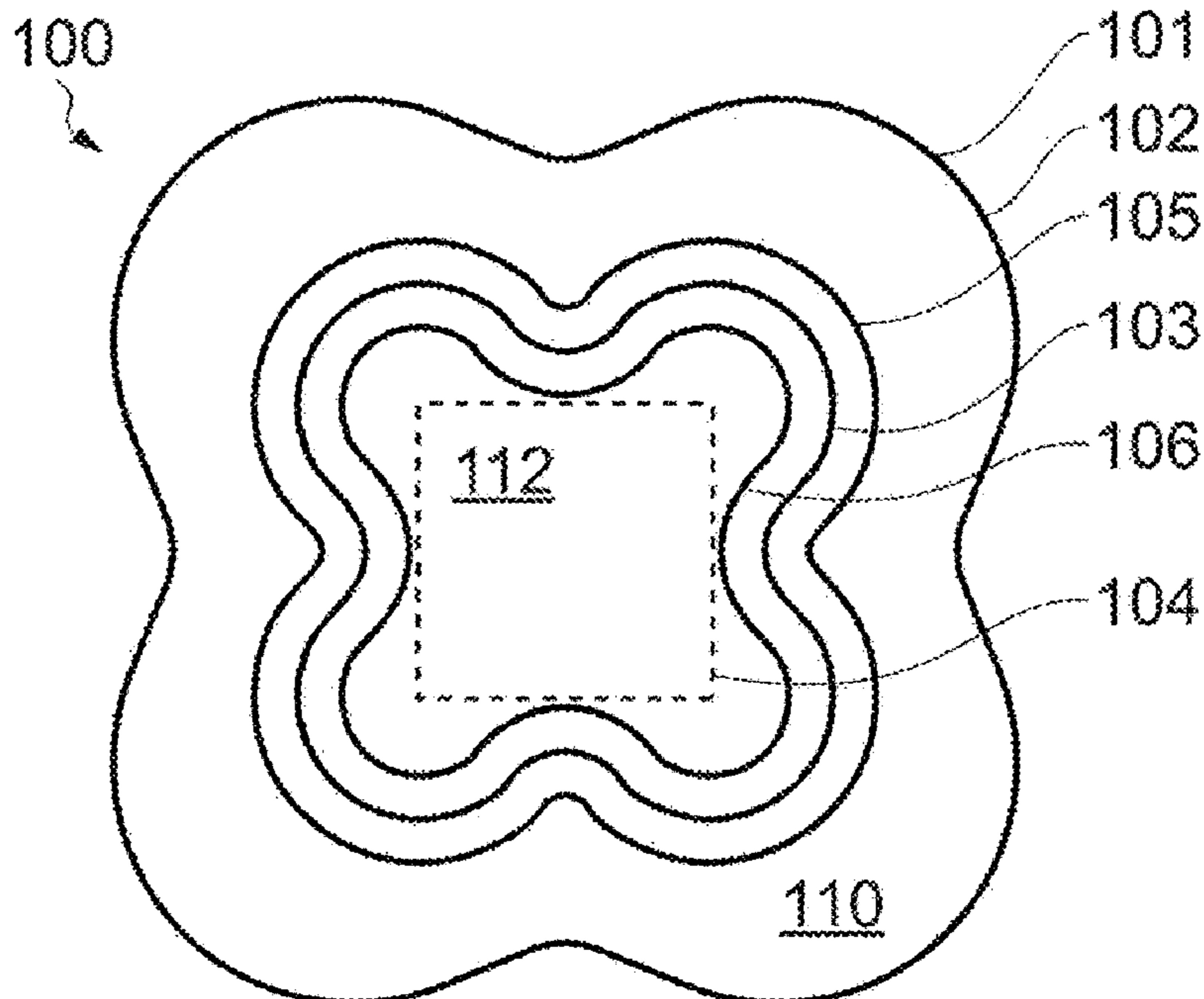
(Continued)

Primary Examiner — David O Reip
(74) *Attorney, Agent, or Firm* — Knobbe, Martens, Olson & Bear, LLP

(57) **ABSTRACT**

A wound dressing, a method of manufacturing a wound dressing, and a method of treating a patient are disclosed. The wound dressing may include an absorbent layer for absorbing wound exudate; and an obscuring element for at least partially obscuring a view of wound exudate absorbed by the absorbent layer in use.

27 Claims, 27 Drawing Sheets



US RE48,535 E

(51)	Int. Cl. <i>A61F 13/00</i> (2006.01) <i>A61F 13/02</i> (2006.01)				
(52)	U.S. Cl. CPC .. <i>A61F 13/00063</i> (2013.01); <i>A61F 13/00068</i> (2013.01); <i>A61F 13/00987</i> (2013.01); <i>A61F 13/022</i> (2013.01); <i>A61F 13/0203</i> (2013.01); <i>A61F 13/0206</i> (2013.01); <i>A61F 13/0223</i> (2013.01); <i>A61F 13/0226</i> (2013.01); <i>A61F 13/0253</i> (2013.01); <i>A61M 1/0088</i> (2013.01)				
(58)	Field of Classification Search CPC <i>A61F 13/00068</i> ; <i>A61F 13/00987</i> ; <i>A61F 13/022</i> ; <i>A61F 13/0203</i> ; <i>A61F 13/0206</i> ; <i>A61F 13/0223</i> ; <i>A61F 13/0226</i> ; <i>A61F 13/0253</i> ; <i>A61M 1/0088</i> See application file for complete search history.				
(56)	References Cited U.S. PATENT DOCUMENTS				
	2,054,768 A * 9/1936 Gale, Jr. A61F 13/0203 602/59				5,336,219 A 8/1994 Krantz 5,342,336 A 8/1994 Meirowitz et al. 5,348,547 A 9/1994 Payne et al. 5,354,261 A 10/1994 Clark et al. 5,356,405 A 10/1994 Thompson et al. 5,360,420 A 11/1994 Cook et al. 5,364,381 A 11/1994 Soga et al. 5,364,382 A 11/1994 Latimer et al. 5,366,451 A 11/1994 Levesque 5,368,909 A 11/1994 Langdon et al. 5,368,926 A 11/1994 Thompson et al. 5,374,260 A 12/1994 Lemay et al. 5,380,294 A 1/1995 Persson 5,382,245 A 1/1995 Thompson et al. 5,387,208 A 2/1995 Ashton et al. 5,387,209 A 2/1995 Yamamoto et al. 5,397,316 A 3/1995 LaVon et al. 5,401,267 A 3/1995 Couture-Dorschner et al. 5,425,725 A 6/1995 Tanzer et al. 5,431,643 A 7/1995 Ouellette et al. 5,437,651 A 8/1995 Todd et al. 5,447,492 A 9/1995 Cartmell et al. 5,454,800 A 10/1995 Hirt et al. 5,456,660 A 10/1995 Reich et al. 5,465,735 A 11/1995 Patel 5,470,326 A 11/1995 Dabi et al. H1511 H 12/1995 Chappell et al. H1511 H 12/1995 Chappell et al. 5,480,377 A 1/1996 Cartmell et al. 5,486,167 A 1/1996 Dragoo et al. 5,487,736 A 1/1996 Van Phan 5,497,788 A 3/1996 Inman et al. 5,500,270 A 3/1996 Langdon et al. 5,505,719 A 4/1996 Cohen et al. 5,509,914 A 4/1996 Osborn, III 5,514,120 A 5/1996 Johnston et al. 5,520,629 A 5/1996 Heinecke et al. 5,525,407 A 6/1996 Yang 5,536,264 A 7/1996 Hsueh et al. 5,538,500 A 7/1996 Peterson H1585 H 8/1996 Ahr H1585 H 8/1996 Ahr 5,545,155 A 8/1996 Hseih et al. 5,549,584 A 8/1996 Gross 5,549,589 A 8/1996 Horney et al. 5,562,107 A 10/1996 Lavender et al. 5,562,646 A 10/1996 Goldman et al. 5,562,650 A 10/1996 Everett et al. 5,579,765 A 12/1996 Cox et al. D377,529 S 1/1997 Nyqvist-Mayer 5,591,148 A 1/1997 McFall et al. 5,591,149 A 1/1997 Cree et al. 5,593,395 A * 1/1997 Martz A61F 13/023 602/58
	3,156,242 A 11/1964 Crowe 3,204,277 A 9/1965 Visman et al. 3,301,429 A 1/1967 McClain 3,416,524 A 12/1968 Meier 3,529,597 A * 9/1970 Fuzak A61F 13/105 602/58				
	3,687,136 A 8/1972 Carmody D228,338 S 9/1973 O'Neil 4,212,296 A * 7/1980 Schaar A61F 13/0203 128/888				
	D281,794 S 12/1985 Short 4,649,909 A 3/1987 Thompson 4,798,603 A 1/1989 Meyer et al. 4,834,735 A 5/1989 Alemany et al. 4,846,164 A 7/1989 Martz 4,901,714 A * 2/1990 Jensen A61F 13/0203 128/846				
	4,968,181 A 11/1990 Goldman 4,973,325 A 11/1990 Sherrod et al. 4,988,344 A 1/1991 Reising et al. 4,988,345 A 1/1991 Reising 5,018,515 A 5/1991 Gilman 5,021,050 A 6/1991 Iskra 5,037,409 A 8/1991 Chen et al. 5,065,600 A 11/1991 Byles 5,115,801 A 5/1992 Cartmell et al. 5,124,197 A 6/1992 Bernardin et al. 5,149,334 A 9/1992 Lahrman et al. 5,151,091 A 9/1992 Glaug et al. 5,160,328 A 11/1992 Cartmell et al. 5,171,391 A 12/1992 Chmielewski et al. 5,175,046 A 12/1992 Nguyen 5,176,663 A 1/1993 Svedman et al. 5,197,945 A 3/1993 Cole et al. 5,217,445 A 6/1993 Young et al. 5,236,427 A 8/1993 Hamajima et al. 5,242,435 A 9/1993 Murji et al. 5,257,982 A 11/1993 Cohen et al. 5,271,987 A 12/1993 Iskra 5,281,208 A 1/1994 Thompson et al. 5,294,478 A 3/1994 Wanek et al. 5,296,290 A 3/1994 Brassington 5,314,743 A 5/1994 Meirowitz et al. 5,318,554 A 6/1994 Young et al. 5,330,456 A 7/1994 Robinson				5,603,707 A 2/1997 Trombetta et al. 5,603,946 A 2/1997 Constantine 5,609,588 A 3/1997 DiPalma et al. 5,613,960 A 3/1997 Mizutani 5,614,283 A 3/1997 Pontis et al. 5,614,295 A 3/1997 Quincy, III et al. 5,628,736 A 5/1997 Thompson 5,632,731 A 5/1997 Patel H1657 H 6/1997 Hammons et al. H1657 H 6/1997 Hammons et al. 5,634,915 A 6/1997 Osterdahl 5,636,643 A 6/1997 Argenta et al. 5,637,080 A 6/1997 Geng 5,643,238 A 7/1997 Baker 5,645,081 A 7/1997 Argenta et al. 5,648,142 A 7/1997 Phillips 5,649,915 A 7/1997 Chauvette et al. 5,649,916 A 7/1997 DiPalma et al. 5,662,599 A 9/1997 Reich et al. 5,665,082 A 9/1997 Boulanger 5,669,895 A 9/1997 Murakami et al. D385,038 S 10/1997 Shultz 5,675,079 A 10/1997 Gilman et al. 5,683,354 A 11/1997 Levy 5,700,254 A 12/1997 McDowall et al.

(56)

References Cited

U.S. PATENT DOCUMENTS

5,702,356 A	12/1997	Hathman	D454,955 S	3/2002	Dunshee et al.
5,704,905 A	1/1998	Jensen et al.	6,362,390 B1	3/2002	Carlucci et al.
5,713,384 A	2/1998	Roach et al.	6,369,292 B1	4/2002	Strack et al.
5,713,842 A	2/1998	Kay	6,372,952 B1	4/2002	Lash et al.
5,716,703 A	2/1998	Payne	6,403,857 B1	6/2002	Gross et al.
5,728,084 A	3/1998	Palumbo et al.	6,461,339 B1	10/2002	Sugahara
5,728,085 A	3/1998	Widlund et al.	6,468,295 B2	10/2002	Augustine et al.
5,733,273 A	3/1998	Ahr	D467,629 S	12/2002	Manville
5,752,945 A	5/1998	Mosley et al.	6,497,689 B1	12/2002	Schmidt et al.
5,762,641 A	6/1998	Bewick-Sonntag et al.	D468,574 S	1/2003	Moore
5,788,684 A	8/1998	Abuto et al.	6,506,175 B1	1/2003	Goldstein
5,801,107 A	9/1998	Everhart et al.	6,506,960 B1	1/2003	Young et al.
5,810,798 A	9/1998	Finch et al.	6,521,813 B1	2/2003	Chihani
5,817,081 A	10/1998	LaVon et al.	D472,281 S	3/2003	Manville
5,820,578 A	10/1998	Johansen	6,528,696 B1	3/2003	Ireland
5,827,213 A	10/1998	Jensen	6,534,149 B1	3/2003	Daley et al.
5,827,254 A	10/1998	Trombetta et al.	6,545,194 B1	4/2003	Schmidt et al.
5,830,202 A	11/1998	Bogdanski et al.	6,551,295 B1	4/2003	Schmidt et al.
5,837,627 A	11/1998	Halabisky et al.	6,552,244 B1	4/2003	Jacques et al.
5,840,052 A	11/1998	Johns	D474,842 S	5/2003	Wolsing et al.
5,843,025 A	12/1998	Shaari	6,570,057 B1	5/2003	Schmidt et al.
5,843,064 A	12/1998	Koczab	6,570,058 B1	5/2003	Fuchs et al.
5,855,572 A	1/1999	Schmidt	6,573,424 B1	6/2003	Raidel et al.
5,865,822 A	2/1999	Hamajima et al.	6,586,653 B2	7/2003	Graeme, III et al.
5,865,824 A	2/1999	Chen et al.	6,610,898 B1	8/2003	Magnusson et al.
5,873,867 A	2/1999	Coles et al.	6,610,903 B1	8/2003	Latimer et al.
5,877,097 A	3/1999	West et al.	D480,144 S	9/2003	Adams et al.
D408,541 S	4/1999	Dunshee et al.	6,613,028 B1	9/2003	Daley et al.
5,891,120 A	4/1999	Chmielewski	6,613,953 B1	9/2003	Altura
5,895,379 A	4/1999	Litchholt et al.	6,613,955 B1	9/2003	Lindsay et al.
5,897,541 A	4/1999	Uitenbroek et al.	6,626,891 B2	9/2003	Ohmstede
5,981,120 A	4/1999	Chmielewski	6,630,611 B1	10/2003	Malowaniec
D409,754 S	5/1999	Dunshee et al.	6,648,862 B2	11/2003	Watson
5,916,507 A	6/1999	Dabi et al.	D484,601 S	12/2003	Griffiths et al.
5,925,026 A	7/1999	Arteman et al.	D484,602 S	12/2003	Griffiths et al.
5,931,823 A	8/1999	Stokes et al.	6,664,439 B1	12/2003	Arndt et al.
5,938,995 A	8/1999	Koltisko, Jr. et al.	6,683,229 B1	1/2004	Ehrnsperger et al.
5,941,863 A	8/1999	Guidotti et al.	6,685,681 B2	2/2004	Lockwood et al.
5,947,945 A	9/1999	Cree et al.	6,706,940 B2	3/2004	Worthley
5,951,535 A	9/1999	Fujiwara et al.	6,719,742 B1	4/2004	McCormack et al.
5,961,506 A	10/1999	Guidotti et al.	6,727,403 B1	4/2004	Ehrnsperger et al.
5,968,027 A	10/1999	Cole et al.	6,752,794 B2	6/2004	Lockwood et al.
5,989,478 A	11/1999	Ouellette et al.	D493,230 S	7/2004	Liedtke et al.
D419,273 S	1/2000	France	6,762,337 B2	7/2004	Boukanov et al.
6,022,610 A	2/2000	Phan et al.	6,764,459 B1	7/2004	Donaldson
6,037,518 A	3/2000	Guidotti et al.	6,776,769 B2	8/2004	Smith
6,040,493 A	3/2000	Cooke et al.	6,783,837 B1	8/2004	Creagan et al.
6,060,638 A	5/2000	Paul et al.	6,787,682 B2	9/2004	Gilman
6,068,620 A	5/2000	Chmielewski	6,835,192 B1	12/2004	Guidotti et al.
6,071,267 A	6/2000	Zamierowski	6,838,589 B2*	1/2005	Liedtke A61F 13/0203
6,075,177 A	6/2000	Bahia et al.			602/42
6,077,526 A	6/2000	Scully et al.	6,841,715 B2	1/2005	Roberts
6,096,015 A	8/2000	Yeo et al.	D501,926 S	2/2005	Shaw et al.
6,103,953 A	8/2000	Cree et al.	D503,982 S	4/2005	Liedtke et al.
6,103,954 A	8/2000	Grondin et al.	6,936,037 B2	8/2005	Bubb et al.
6,107,539 A	8/2000	Palumbo et al.	D511,005 S	10/2005	Liedtke et al.
D430,674 S	9/2000	Dunshee et al.	6,951,553 B2	10/2005	Bubb et al.
6,117,523 A	9/2000	Sugahara	6,960,181 B2	11/2005	Stevens
6,124,520 A	9/2000	Roberts	6,998,511 B2	2/2006	Worthley
6,124,521 A	9/2000	Roberts	7,004,915 B2	2/2006	Boynton et al.
D433,140 S	10/2000	Nielsen	D516,729 S	3/2006	Liedtke et al.
6,127,595 A	10/2000	Makoui et al.	7,049,478 B1	5/2006	Smith et al.
6,142,982 A	11/2000	Hunt et al.	7,108,683 B2	9/2006	Zamierowski
6,168,849 B1	1/2001	Braverman et al.	7,112,712 B1	9/2006	Ancell
6,191,340 B1	2/2001	Carlucci et al.	7,118,545 B2	10/2006	Boyde
6,206,865 B1	3/2001	Chen et al.	7,122,023 B1	10/2006	Hinoki
6,223,383 B1	5/2001	VanPutten	7,122,712 B2	10/2006	Lutri et al.
6,235,964 B1	5/2001	Kadash et al.	7,183,345 B2	2/2007	Kim
6,235,966 B1	5/2001	Magnusson et al.	7,195,624 B2	3/2007	Lockwood
6,264,776 B1	7/2001	DiPalma	7,294,751 B2	11/2007	Propp et al.
6,294,710 B1	9/2001	Schmidt et al.	7,294,752 B1	11/2007	Propp
6,297,423 B1	10/2001	Schoenfeldt et al.	D556,823 S	12/2007	Lombard
D452,121 S	12/2001	Teichelman	D557,424 S	12/2007	Knight
6,344,036 B1	2/2002	Ivansson	D571,922 S	6/2008	Freeland
6,345,623 B1	2/2002	Heaton et al.	7,381,859 B2	6/2008	Hunt et al.
			D572,367 S	7/2008	Freeland
			D572,824 S	7/2008	Propp
			D572,825 S	7/2008	Freeland
			7,429,689 B2	9/2008	Chen et al.

(56)

References Cited

U.S. PATENT DOCUMENTS

7,438,705 B2	10/2008	Karpowicz et al.	8,791,316 B2	7/2014	Greener
7,476,205 B2	1/2009	Erdmann	8,795,247 B2	8/2014	Bennett et al.
7,507,870 B2	3/2009	Nielsen et al.	8,801,685 B2	8/2014	Armstrong et al.
7,511,187 B2	3/2009	Kelly	8,814,842 B2	8/2014	Coulthard et al.
7,563,940 B2	7/2009	Kurata	8,829,263 B2	9/2014	Haggstrom et al.
7,569,742 B2	8/2009	Haggstrom et al.	8,843,327 B2	9/2014	Vernon-Harcourt et al.
7,576,256 B2	8/2009	Björnberg et al.	8,916,742 B2	12/2014	Smith
D600,354 S	9/2009	Sachi	D722,699 S	2/2015	Riesinger
7,605,298 B2	10/2009	Bechert et al.	8,986,270 B2	3/2015	Johannison et al.
D604,424 S	11/2009	Coubetergues	9,012,714 B2	4/2015	Fleischmann
7,615,036 B2	11/2009	Joshi et al.	9,033,942 B2	5/2015	Vess
7,622,629 B2	11/2009	Aail	9,061,095 B2	6/2015	Adie et al.
D605,299 S	12/2009	Iwahashi et al.	9,220,822 B2	12/2015	Hartwell et al.
D607,112 S	12/2009	Rogers et al.	9,254,353 B2	2/2016	Locke et al.
7,645,269 B2	1/2010	Zamierowski	9,265,665 B2	2/2016	Robinson et al.
D609,922 S	2/2010	Bridges et al.	2001/0000795 A1	5/2001	Bolian, II et al.
7,676,257 B2	3/2010	Suryanarayanan et al.	2001/0016985 A1	8/2001	Insley et al.
7,722,582 B2	5/2010	Lina et al.	2001/0018308 A1	8/2001	Quick et al.
7,723,561 B2	5/2010	Propp	2001/0027302 A1	10/2001	Glaug et al.
D618,810 S	6/2010	Tanigawa et al.	2001/0027305 A1	10/2001	Raidel et al.
D620,122 S	7/2010	Cotton	2001/0044610 A1	11/2001	Kim et al.
D620,123 S	7/2010	Igwebuike	2001/0051178 A1	12/2001	Blatchford et al.
7,749,531 B2	7/2010	Booher	2001/0053904 A1	12/2001	Abuto
7,759,537 B2	7/2010	Bishop et al.	2002/0007167 A1	1/2002	Dan et al.
7,759,539 B2	7/2010	Shaw et al.	2002/0007169 A1	1/2002	Graef et al.
7,775,998 B2	8/2010	Riesinger	2002/0019602 A1	2/2002	Geng
7,776,028 B2	8/2010	Miller et al.	2002/0019614 A1	2/2002	Woon et al.
7,779,625 B2	8/2010	Joshi et al.	2002/0026166 A1	2/2002	Graef et al.
7,794,438 B2	9/2010	Henley et al.	2002/0034914 A1	3/2002	De Leon et al.
D625,017 S	10/2010	Iwahashi et al.	2002/0035354 A1	3/2002	Mirle et al.
7,838,719 B2	11/2010	Hilton, Jr.	2002/0062113 A1	5/2002	Thomas et al.
7,838,723 B1	11/2010	Schmidt et al.	2002/0064639 A1	5/2002	Rearick et al.
7,922,703 B2	4/2011	Riesinger	2002/0087136 A1	7/2002	Widlund
7,935,066 B2	5/2011	Shives et al.	2002/0090511 A1	7/2002	Smith et al.
7,959,624 B2	6/2011	Riesinger	2002/0110672 A1	8/2002	Muratore-Pallatino et al.
7,964,766 B2	6/2011	Blott et al.	2002/0123728 A1	9/2002	Graef et al.
7,976,519 B2	7/2011	Bubb et al.	2002/0133132 A1	9/2002	Copat et al.
7,988,673 B2	8/2011	Wright et al.	2002/0150678 A1	10/2002	Cramer et al.
8,021,347 B2	9/2011	Vitaris et al.	2002/0165509 A1	11/2002	Baer et al.
8,080,702 B2	12/2011	Blott et al.	2002/0169405 A1	11/2002	Roberts
8,092,436 B2	1/2012	Christensen	2002/0176964 A1	11/2002	Koslow
8,147,468 B2	4/2012	Barta et al.	2002/0177831 A1	11/2002	Daley et al.
8,152,785 B2	4/2012	Vitaris	2002/0180092 A1	12/2002	Abba et al.
8,162,907 B2	4/2012	Heagle	2002/0183704 A1	12/2002	Fields et al.
8,168,848 B2	5/2012	Lockwood et al.	2003/0009122 A1	1/2003	Veras
8,188,331 B2	5/2012	Barta et al.	2003/0045707 A1	3/2003	West et al.
8,202,261 B2	6/2012	Kazala, Jr. et al.	2003/0045825 A1	3/2003	Etheredge, III
8,212,101 B2	7/2012	Propp	2003/0050617 A1	3/2003	Chen et al.
8,241,261 B2	8/2012	Randolph et al.	2003/0069563 A1	4/2003	Johnson
8,246,606 B2	8/2012	Stevenson et al.	2003/0070780 A1	4/2003	Chen et al.
8,252,971 B2	8/2012	Aali et al.	2003/0073967 A1	4/2003	Wahlstrom et al.
8,314,283 B2	11/2012	Kingsford et al.	2003/0088229 A1	5/2003	Baker et al.
D672,464 S	12/2012	Holm et al.	2003/0088231 A1	5/2003	Yoshimasa et al.
8,328,858 B2	12/2012	Barsky et al.	2003/0093044 A1	5/2003	Wahlstrom et al.
8,372,050 B2	2/2013	Jaeb et al.	2003/0097101 A1	5/2003	Schmidt et al.
8,376,972 B2	2/2013	Fleischmann	2003/0097105 A1	5/2003	Chen et al.
8,382,731 B2	2/2013	Johannison	2003/0097113 A1	5/2003	Molee
8,403,899 B2	3/2013	Sherman	2003/0105442 A1	6/2003	Johnston et al.
8,404,921 B2	3/2013	Lee et al.	2003/0114816 A1	6/2003	Underhill et al.
D679,819 S	4/2013	Peron	2003/0114818 A1	6/2003	Benecke et al.
D679,820 S	4/2013	Peron	2003/0114821 A1	6/2003	Underhill et al.
8,425,478 B2	4/2013	Olson	2003/0120249 A1	6/2003	Wulz et al.
8,449,508 B2	5/2013	Coulthard et al.	2003/0121588 A1	7/2003	Pargass et al.
D683,858 S	6/2013	Smith	2003/0124311 A1	7/2003	Cree et al.
8,513,481 B2	8/2013	Gergeley et al.	2003/0134559 A1	7/2003	Delzer et al.
8,535,296 B2	9/2013	Blott et al.	2003/0135174 A1	7/2003	Benecke et al.
D691,730 S	10/2013	Smith et al.	2003/0135177 A1	7/2003	Baker
D692,565 S	10/2013	Lattimore et al.	2003/0150551 A1	8/2003	Baker
8,545,466 B2	10/2013	Andresen et al.	2003/0157857 A1	8/2003	Cook et al.
D693,888 S	11/2013	Webster	2003/0171729 A1	9/2003	Kaun et al.
8,663,198 B2	3/2014	Buan et al.	2003/0180341 A1	9/2003	Gooch et al.
8,680,360 B2	3/2014	Greener et al.	2003/0199800 A1	10/2003	Levin
8,715,256 B2	5/2014	Greener	2003/0208175 A1	11/2003	Gross et al.
8,722,961 B2	5/2014	Vinton et al.	2003/0212359 A1	11/2003	Butler
8,764,732 B2	7/2014	Hartwell	2003/0225383 A1	12/2003	Glaug et al.
			2004/0019338 A1	1/2004	Litvay et al.
			2004/0019339 A1	1/2004	Ranganathan et al.
			2004/0019340 A1	1/2004	McBride
			2004/0019342 A1	1/2004	Nagasuna et al.

(56)		References Cited					
		U.S. PATENT DOCUMENTS					
2004/0024375	A1	2/2004	Litvay	2008/0058692	A1	3/2008	Propp et al.
2004/0033750	A1	2/2004	Everett et al.	2008/0082075	A1	4/2008	Morrell-Schwartz
2004/0049146	A1	3/2004	Kolte et al.	2008/0090050	A1	4/2008	Seyler et al.
2004/0054343	A1	3/2004	Barnett et al.	2008/0091152	A1*	4/2008	Asherman A61M 1/04 604/315
2004/0054344	A1	3/2004	Roettger et al.	2008/0114317	A1	5/2008	Seyler
2004/0065420	A1	4/2004	Graef et al.	2008/0119586	A1	5/2008	Byerly et al.
2004/0076662	A1	4/2004	Riesinger	2008/0147024	A1	6/2008	Potts et al.
2004/0078011	A1	4/2004	Stevens	2008/0167592	A1	7/2008	Greer
2004/0078016	A1	4/2004	Baker	2008/0243100	A1	10/2008	Wu et al.
2004/0087927	A1	5/2004	Suzuki	2008/0254103	A1	10/2008	Harris et al.
2004/0106888	A1	6/2004	Lutri et al.	2008/0255533	A1	10/2008	Wu et al.
2004/0111074	A1	6/2004	Eliasson	2008/0275409	A1	11/2008	Kane et al.
2004/0127862	A1	7/2004	Bubb et al.	2008/0312621	A1	12/2008	Hundorf et al.
2004/0138602	A1	7/2004	Rossen	2008/0312622	A1	12/2008	Hundorf et al.
2004/0177935	A1	9/2004	Hamed et al.	2009/0062760	A1	3/2009	Wright et al.
2004/0181199	A1	9/2004	Moberg-Alehammar et al.	2009/0065014	A1	3/2009	Nagata
2004/0204696	A1	10/2004	Chen	2009/0076472	A1	3/2009	Goldwasser et al.
2004/0230173	A1	11/2004	Barge et al.	2009/0112175	A1	4/2009	Bissah et al.
2004/0230184	A1	11/2004	Babusik et al.	2009/0126103	A1	5/2009	Dietrich et al.
2004/0241214	A1	12/2004	Kirkwood et al.	2009/0204087	A1	8/2009	Herfert et al.
2004/0243042	A1	12/2004	Lipman	2009/0216168	A1	8/2009	Eckstein et al.
2004/0243080	A1	12/2004	Baer	2009/0227935	A1*	9/2009	Zanella A61N 1/0468 604/20
2004/0243081	A1	12/2004	Suzuki et al.	2009/0227969	A1	9/2009	Jaeb et al.
2004/0253894	A1	12/2004	Fell et al.	2009/0240218	A1	9/2009	Braga et al.
2004/0254552	A1	12/2004	Mangold	2009/0281471	A1	11/2009	Iwahashi et al.
2005/0008825	A1	1/2005	Casey et al.	2009/0293887	A1	12/2009	Wilkes et al.
2005/0013992	A1	1/2005	Azad et al.	2009/0299251	A1	12/2009	Buan
2005/0015036	A1	1/2005	Lutri et al.	2009/0299255	A1	12/2009	Kazala, Jr. et al.
2005/0049566	A1	3/2005	Vukos et al.	2009/0299340	A1	12/2009	Kazala et al.
2005/0079361	A1	4/2005	Hamed et al.	2010/0010461	A1	1/2010	Herfert et al.
2005/0096616	A1	5/2005	Arora et al.	2010/0030171	A1	2/2010	Canada et al.
2005/0112979	A1	5/2005	Sawyer et al.	2010/0036334	A1	2/2010	Heagle et al.
2005/0119631	A1	6/2005	Giloh et al.	2010/0036342	A1	2/2010	Carlucci et al.
2005/0136773	A1	6/2005	Yahiaoui et al.	2010/0048072	A1	2/2010	Kauschke et al.
2005/0165371	A1	7/2005	Giacometti	2010/0055158	A1	3/2010	Vitaris et al.
2005/0215965	A1	9/2005	Schmidt et al.	2010/0069858	A1	3/2010	Olson
2005/0215967	A1	9/2005	Toro et al.	2010/0084074	A1	4/2010	McClernon et al.
2005/0222547	A1	10/2005	Beruda et al.	2010/0087767	A1	4/2010	McNeil
2005/0228353	A1	10/2005	Thomas	2010/0106120	A1	4/2010	Holm
2005/0261649	A1	11/2005	Cohen	2010/0106121	A1*	4/2010	Holm A61F 13/0203 604/368
2005/0267429	A1	12/2005	Cohen	2010/0121286	A1	5/2010	Locke et al.
2006/0003604	A1	1/2006	Angerpointner	2010/0121298	A1	5/2010	Seyler et al.
2006/0009744	A1	1/2006	Edrman et al.	2010/0122417	A1	5/2010	Vrzalik et al.
2006/0020250	A1	1/2006	Chester et al.	2010/0125234	A1	5/2010	Smith
2006/0058750	A1	3/2006	Di Girolamo et al.	2010/0125258	A1	5/2010	Coulthard et al.
2006/0069366	A1	3/2006	Cole	2010/0168695	A1	7/2010	Robles et al.
2006/0069367	A1	3/2006	Waksmundzki et al.	2010/0217177	A1	8/2010	Cali et al.
2006/0069375	A1	3/2006	Waksmundzki et al.	2010/0256545	A1	10/2010	Aali et al.
2006/0122548	A1	6/2006	Abrams	2010/0256584	A1	10/2010	Litvay
2006/0122572	A1	6/2006	Suarez	2010/0256586	A1	10/2010	Bergstrom et al.
2006/0153904	A1	7/2006	Smith et al.	2010/0262091	A1	10/2010	Larsson
2006/0161122	A1	7/2006	Erdman et al.	2010/0305526	A1	12/2010	Robinson et al.
2006/0178650	A1	8/2006	Hakansson et al.	2010/0318047	A1	12/2010	Ducker et al.
2006/0184147	A1	8/2006	Hamed	2010/0318052	A1	12/2010	Ha et al.
2006/0206047	A1	9/2006	Lampe et al.	2010/0324516	A1	12/2010	Braga et al.
2006/0206073	A1	9/2006	Crane et al.	2011/0004172	A1	1/2011	Eckstein et al.
2006/0206074	A1	9/2006	Bernal et al.	2011/0052664	A1	3/2011	Tennican et al.
2006/0241542	A1	10/2006	Gudnason et al.	2011/0054421	A1*	3/2011	Hartwell A61F 13/02 604/319
2006/0282028	A1	12/2006	Howard et al.	2011/0059329	A1	3/2011	Dobrawa et al.
2007/0003604	A1	1/2007	Jones	2011/0060303	A1	3/2011	Bissah et al.
2007/0021697	A1	1/2007	Ginther et al.	2011/0092927	A1	4/2011	Wilkes et al.
2007/0073254	A1	3/2007	Ponomarenko et al.	2011/0098621	A1	4/2011	Fabo et al.
2007/0078467	A1	4/2007	Mullen	2011/0106030	A1	5/2011	Scholz
2007/0100308	A1	5/2007	Miyairi	2011/0112492	A1	5/2011	Bharti et al.
2007/0142804	A1	6/2007	Bernard	2011/0125119	A1	5/2011	Weismantel et al.
2007/0167096	A1	7/2007	Scott	2011/0137222	A1	6/2011	Masini
2007/0167884	A1	7/2007	Mangrum et al.	2011/0152813	A1	6/2011	Ellingson
2007/0224903	A1	9/2007	Chakravarty et al.	2011/0178375	A1	7/2011	Forster
2007/0225663	A1	9/2007	Watt et al.	2011/0183109	A1	7/2011	Seyler et al.
2007/0254550	A1	11/2007	Hamed et al.	2011/0184364	A1	7/2011	Biggs et al.
2007/0270070	A1	11/2007	Hamed	2011/0184370	A1	7/2011	Seyler et al.
2007/0282236	A1	12/2007	LaGreca	2011/0208145	A1	8/2011	Zhang et al.
2008/0004581	A1	1/2008	Babusik et al.	2011/0213286	A1	9/2011	Riesinger
2008/0015532	A1	1/2008	Waksmundzki	2011/0218509	A1	9/2011	Dontas
2008/0058691	A1	3/2008	Sorensen	2011/0223413	A1	9/2011	Herfert et al.

(56)

References Cited

U.S. PATENT DOCUMENTS

2011/0238026 A1 9/2011 Zhang et al.
 2011/0245788 A1 10/2011 Marquez Canada
 2011/0247636 A1 10/2011 Pollack
 2011/0257572 A1 10/2011 Locke et al.
 2011/0268932 A1 11/2011 Catalan et al.
 2012/0004632 A1 1/2012 Zhang et al.
 2012/0045639 A1 2/2012 Whitmore et al.
 2012/0053547 A1 3/2012 Schroeder et al.
 2012/0071848 A1 3/2012 Zhang et al.
 2012/0095426 A1 4/2012 Visscher et al.
 2012/0101465 A1 4/2012 Mcguire, Jr.
 2012/0123311 A1 5/2012 Weidemann-Hendrickson et al.
 2012/0130332 A1 5/2012 Cotton et al.
 2012/0136329 A1 5/2012 Carney
 2012/0143158 A1 6/2012 Yang et al.
 2012/0172778 A1 7/2012 Rastegar et al.
 2012/0197229 A1 8/2012 Buan
 2012/0203145 A1 8/2012 Nilsson
 2012/0203189 A1 8/2012 Barta et al.
 2012/0220968 A1 8/2012 Confalone et al.
 2012/0232502 A1 9/2012 Lowing
 2012/0238932 A1 9/2012 Atteia et al.
 2012/0283529 A1 11/2012 Marchand et al.
 2012/0302440 A1 11/2012 Theliander et al.
 2012/0308780 A1 12/2012 Rottger et al.
 2012/0310186 A1 12/2012 Moghe et al.
 2012/0310197 A1 12/2012 Thomas
 2012/0330252 A1 12/2012 Stokes et al.
 2012/0330253 A1 12/2012 Robinson et al.
 2013/0012902 A1 1/2013 Rovaniemi
 2013/0150814 A1 6/2013 Buan
 2013/0310781 A1 11/2013 Phillips et al.
 2014/0114268 A1 4/2014 Auguste et al.
 2014/0249495 A1 9/2014 Mumby
 2015/0159066 A1 6/2015 Hartwell et al.
 2015/0174304 A1 6/2015 Askem et al.
 2019/0110932 A1 4/2019 Mumby et al.
 2019/0216651 A1 7/2019 Vitaris et al.

FOREIGN PATENT DOCUMENTS

EP 0147119 A2 7/1985
 EP 0 541 251 5/1993
 EP 0 619 105 10/1994
 EP 0 549 781 9/1996
 EP 0 748 894 12/1996
 EP 0 599 871 4/1997
 EP 0 875 224 11/1998
 EP 0928174 A1 7/1999
 EP 0 941 726 9/1999
 EP 1 013 290 6/2000
 EP 1 048 278 11/2000
 EP 1 066 809 1/2001
 EP 1 139 951 10/2001
 EP 1 312 328 5/2003
 EP 1 452 156 9/2004
 EP 2 161 011 3/2010
 EP 2 263 627 12/2010
 EP 2 366 721 9/2011
 EP 2 529 767 12/2012
 GB 2272917 6/1994
 GB 2355228 4/2001
 GB 2435422 8/2007
 GB 2435423 8/2007
 GB 2489947 10/2012
 JP S57-119738 7/1982
 JP 2001-145655 5/2001
 JP 2007-275185 10/2007
 JP 2008-119497 5/2008
 WO WO 1991/11161 8/1991
 WO WO 1991/11162 8/1991
 WO WO 1993/01778 2/1993
 WO WO 1993/01779 2/1993
 WO WO 1993/01780 2/1993
 WO WO 1993/01781 2/1993

WO WO 1993/09745 5/1993
 WO WO 1993/11726 6/1993
 WO WO 1995/13042 5/1995
 WO WO 1995/13776 5/1995
 WO WO 1995/13779 5/1995
 WO WO 1995/14451 6/1995
 WO WO 1995/16424 6/1995
 WO WO 1996/07783 3/1996
 WO WO 1996/21410 7/1996
 WO WO 1997/11658 4/1997
 WO WO 1997/14384 4/1997
 WO WO 1998/20916 5/1998
 WO WO 1998/22279 5/1998
 WO WO 1999/04830 2/1999
 WO WO 1999/39671 8/1999
 WO WO 1999/45876 9/1999
 WO WO 1999/45878 9/1999
 WO WO 1999/56687 11/1999
 WO WO 2000/00016 1/2000
 WO WO 2000/00127 1/2000
 WO WO 2000/00129 1/2000
 WO WO 2000/000130 1/2000
 WO WO 2000/00130 1/2000
 WO WO 2000/00131 1/2000
 WO WO 2000/40190 7/2000
 WO WO 2000/040190 7/2000
 WO WO 2000/42957 7/2000
 WO WO 2000/059438 10/2000
 WO WO 2000/59438 10/2000
 WO WO 2001/072251 10/2001
 WO WO 2001/90465 11/2001
 WO WO 2001/090465 11/2001
 WO WO 2002/17840 3/2002
 WO WO 2002/024132 3/2002
 WO WO 2002/24132 3/2002
 WO WO 2002/026180 4/2002
 WO WO 2002/38096 5/2002
 WO WO 2002/038096 5/2002
 WO WO 2002/076379 10/2002
 WO WO 2003/073971 9/2003
 WO WO 2004/043321 5/2004
 WO WO 2004/073566 9/2004
 WO WO 2004/098474 11/2004
 WO WO 2006/105305 10/2006
 WO WO 2007/035038 3/2007
 WO WO 2007/040606 4/2007
 WO WO 2007/077214 7/2007
 WO WO 2007/077216 7/2007
 WO WO 2007/116347 10/2007
 WO WO 2008/013896 1/2008
 WO WO 2008/049277 5/2008
 WO WO 2008/131895 11/2008
 WO WO 2009/019227 2/2009
 WO WO 2009/019229 2/2009
 WO WO 2009/146441 3/2009
 WO WO 2009/066104 5/2009
 WO WO 2009/066105 5/2009
 WO WO 2009/103031 8/2009
 WO WO 2009/146441 12/2009
 WO WO 2009/152021 12/2009
 WO WO 2010/032951 3/2010
 WO WO 2010/072395 7/2010
 WO WO 2010/082872 7/2010
 WO WO 2010/089448 8/2010
 WO WO 2010/139926 12/2010
 WO WO 2011/019476 2/2011
 WO WO 2011/023275 3/2011
 WO WO 2011/023650 3/2011
 WO WO 2011/058311 5/2011
 WO WO 2011/080427 7/2011
 WO WO 2011/113728 9/2011
 WO WO 2011/115908 9/2011
 WO WO 2011/128651 10/2011
 WO WO 2011/135284 11/2011
 WO WO 2011/152368 12/2011
 WO WO 2012/009370 1/2012
 WO WO 2012/035787 3/2012
 WO WO 2012/074512 6/2012
 WO WO 2012/146656 11/2012

(56)

References Cited

FOREIGN PATENT DOCUMENTS

WO	WO 2012/150235	11/2012
WO	WO 2012/168298	12/2012
WO	WO 2013/014317	1/2013
WO	WO 2013/029652	3/2013
WO	WO 2013/060732	5/2013
WO	WO 2013/136181	9/2013
ZA	9605526	2/1997

OTHER PUBLICATIONS

Allevyn Wound Dressings Pamphlet, Smith & Nephew, Inc., 2008.
 KCI Licensing, Prevena™ Incision Management System, Jan. 2010, in 2 pages.
 KCI, Prevena™ Incision Management System Clinician Guide, Jan. 2010, in 10 pages.
 KCI, Prevena™ Incision Management System—Clinician Guide, Jan. 2010, in 12 pages.
 KCI Licensing, Prevena™ Incision Management System Patient Guide, Jan. 2010, in 4 pages.

KCI Licensing, Prevena™ Incision Management System—Patient Guide, Jan. 2010, in 6 pages.

Smith & Nephew, Allevyn Gentle Border Multisite, Jun. 2011, in 2 pages.

International Search Report and Written Opinion, re PCT Application No. PCT/GB2012/000587, dated Oct. 8, 2013.

International Preliminary Report on Patentability, re PCT Application No. PCT/GB2012/000587, dated Jan. 23, 2014.

Brief Communication—Letter from the Opponent of the Patent dated Oct. 12, 2020, for withdraw the Opposition of European Patent No. EP2731564, 4 pages.

Brief Communication—Letter from the Proprietor of the Patent dated Jun. 16, 2020, for the Opposition of European Patent No. EP2731564, 19 pages.

KCI Licensing, Prevena™ Incision Management System, Jun. 22, 2010, in 2 pages.

Notice of Opposition—Statement of Facts and Evidence for the Opposition of European Patent No. 2731564, mailed on Jan. 22, 2020, 12 pages.

* cited by examiner

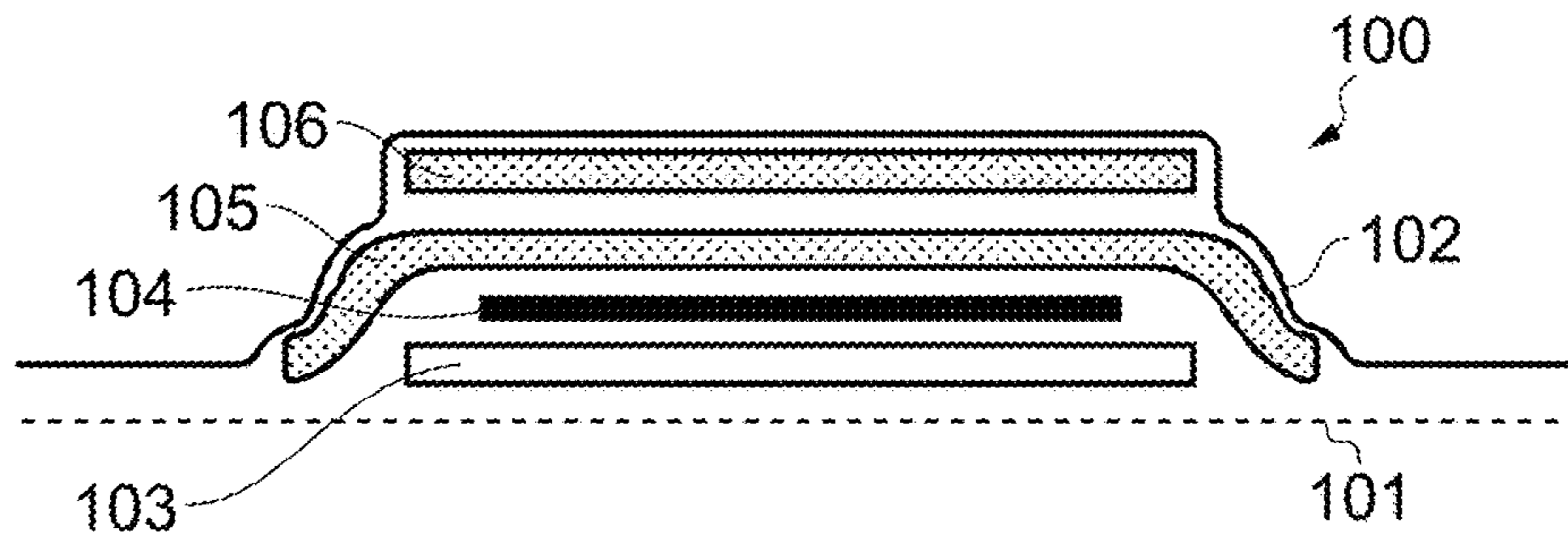


FIG. 1

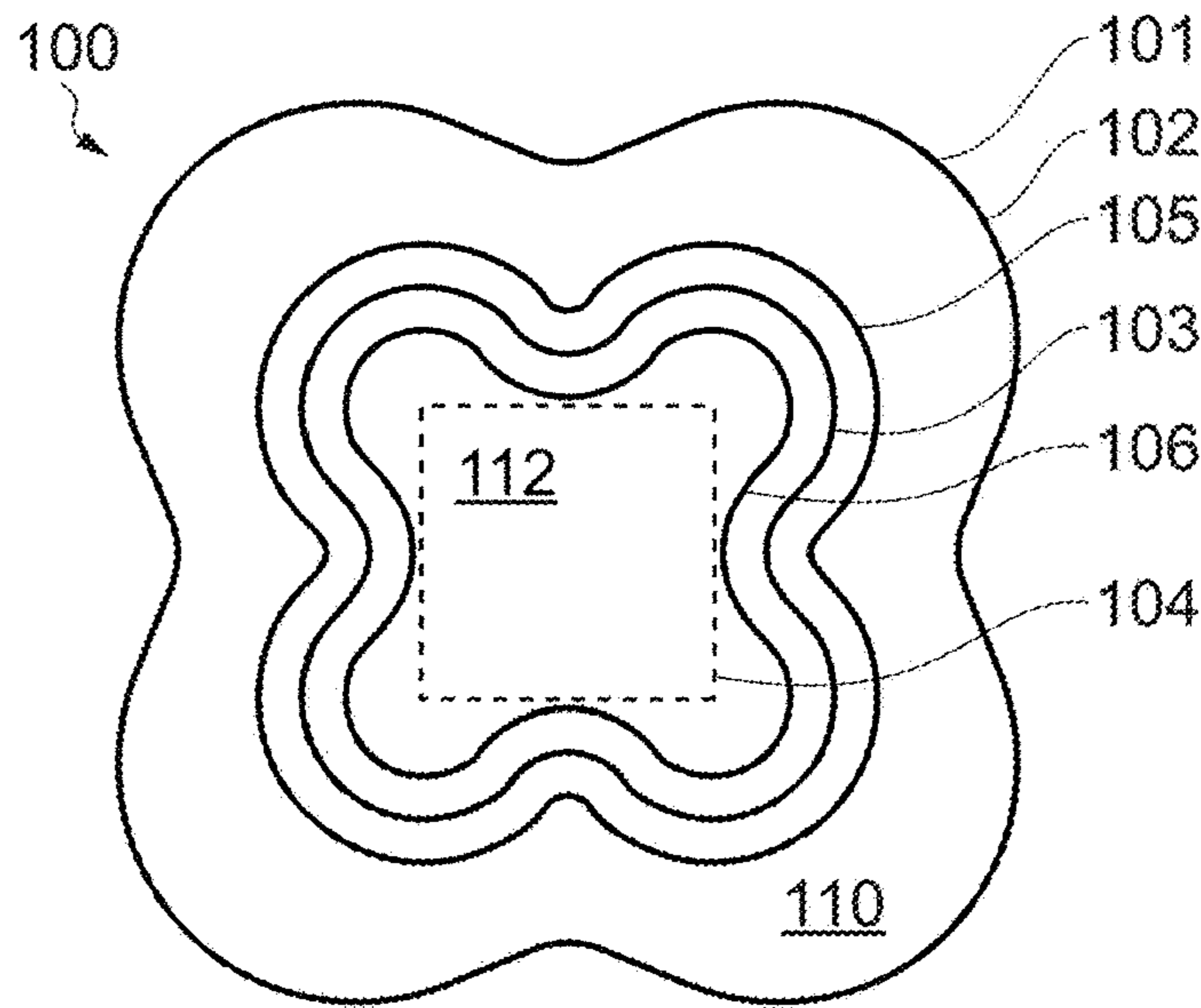


FIG. 2a

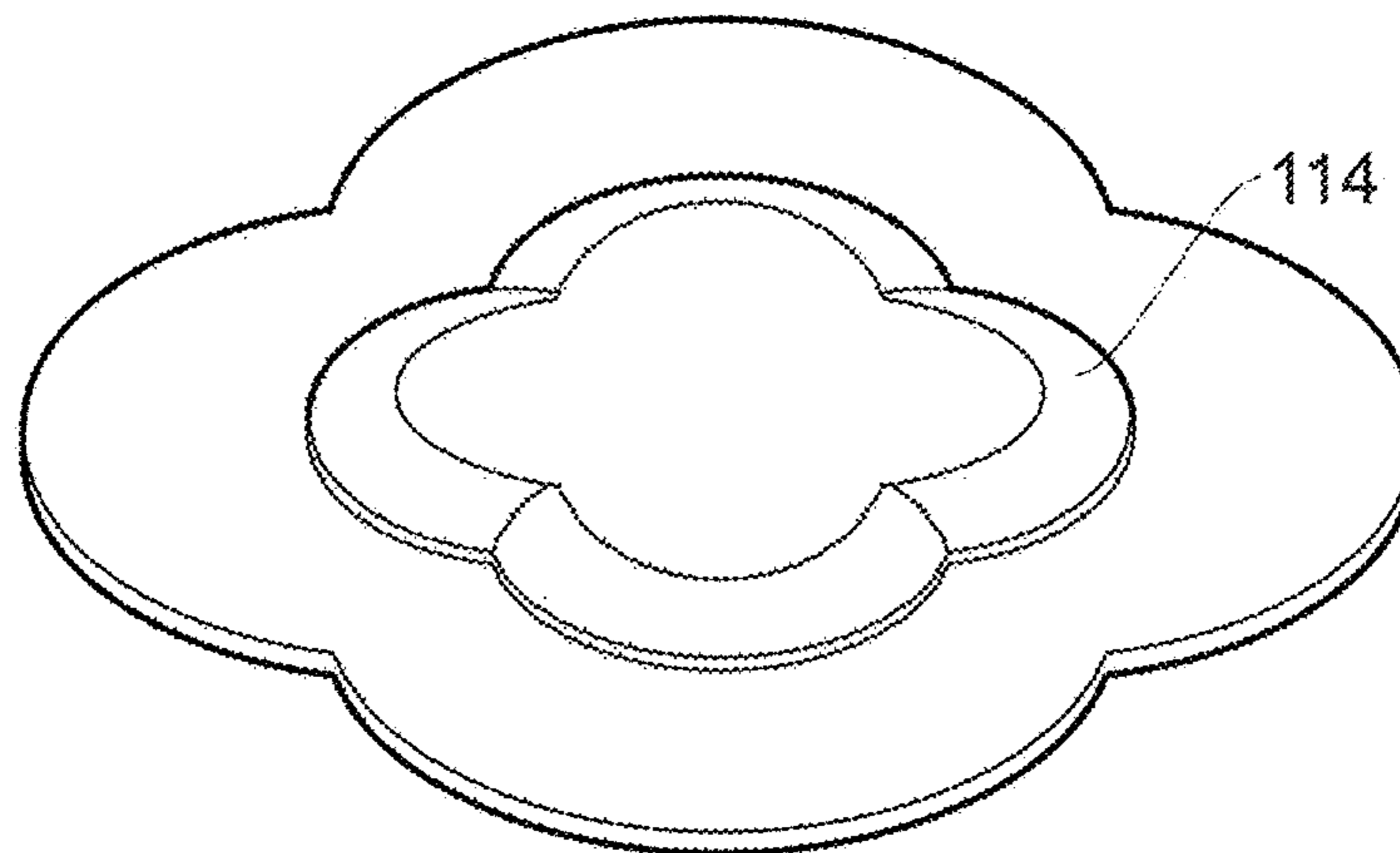


FIG. 2b

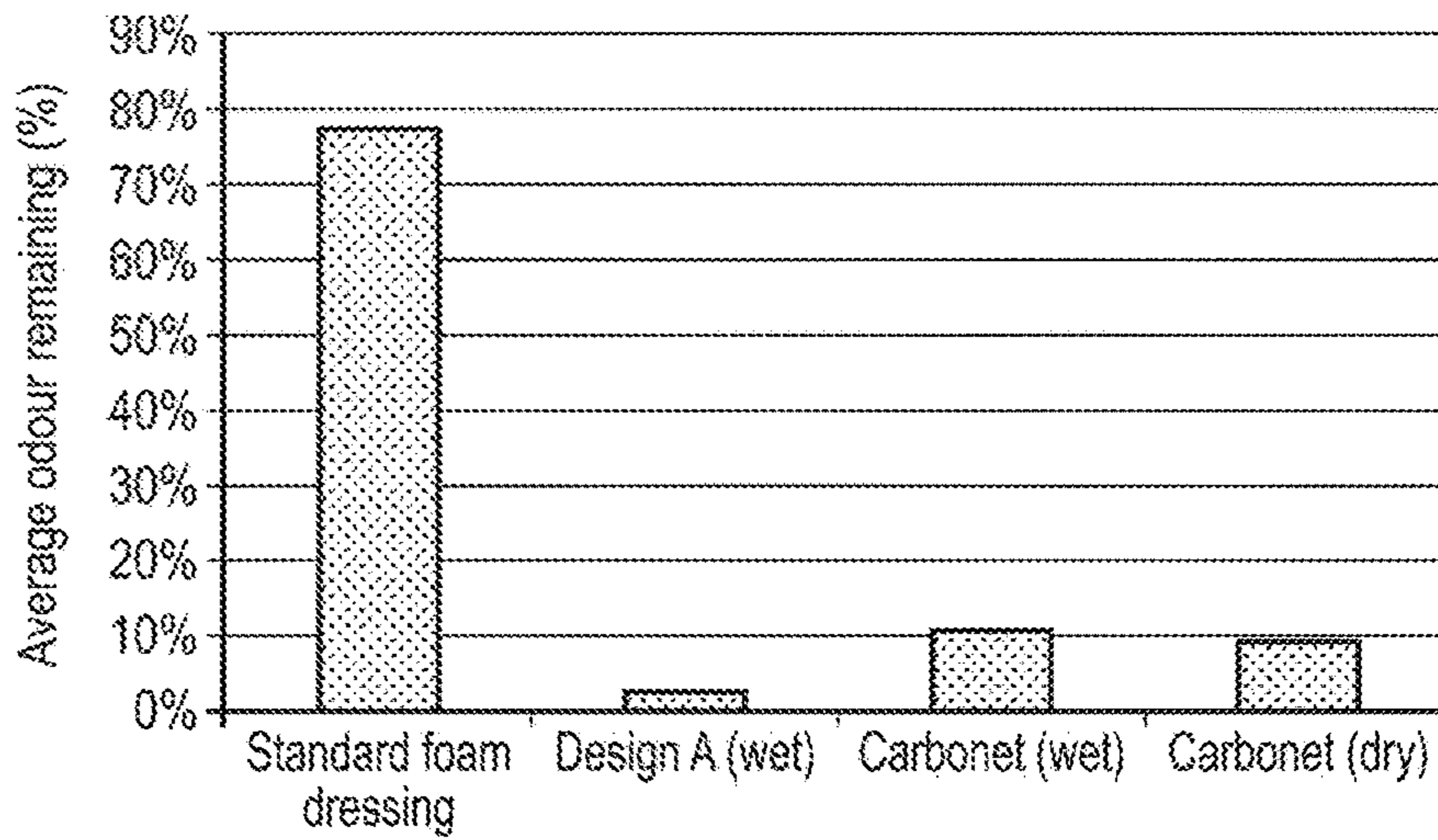
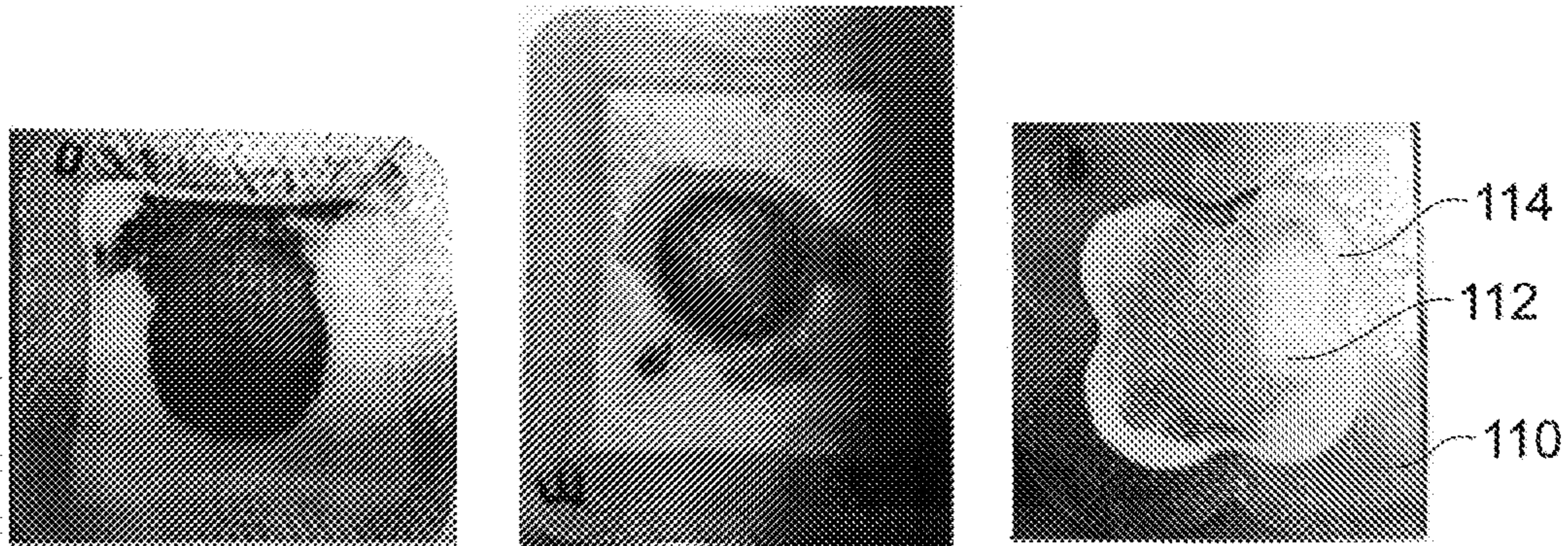


FIG. 4

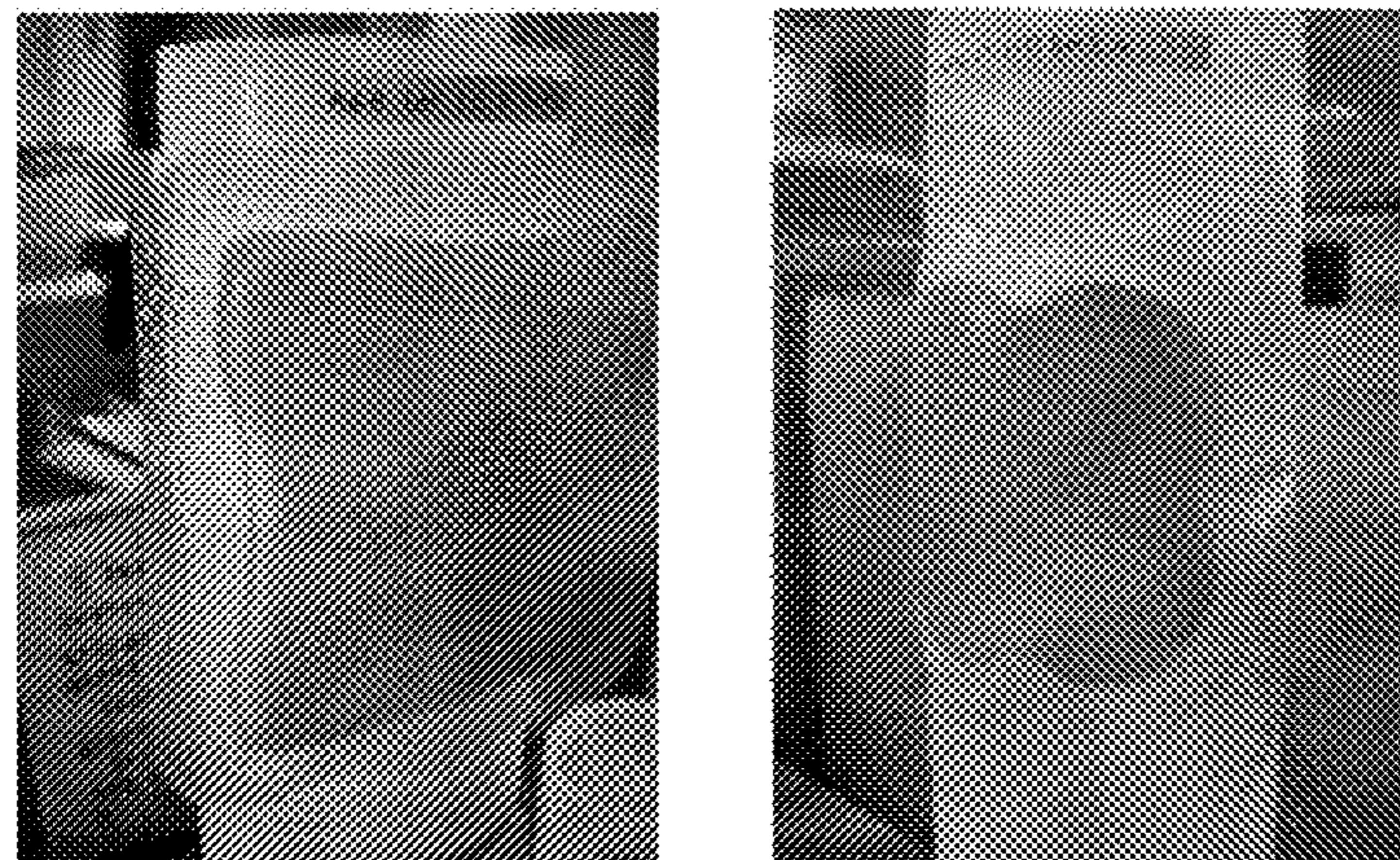


FIG. 5

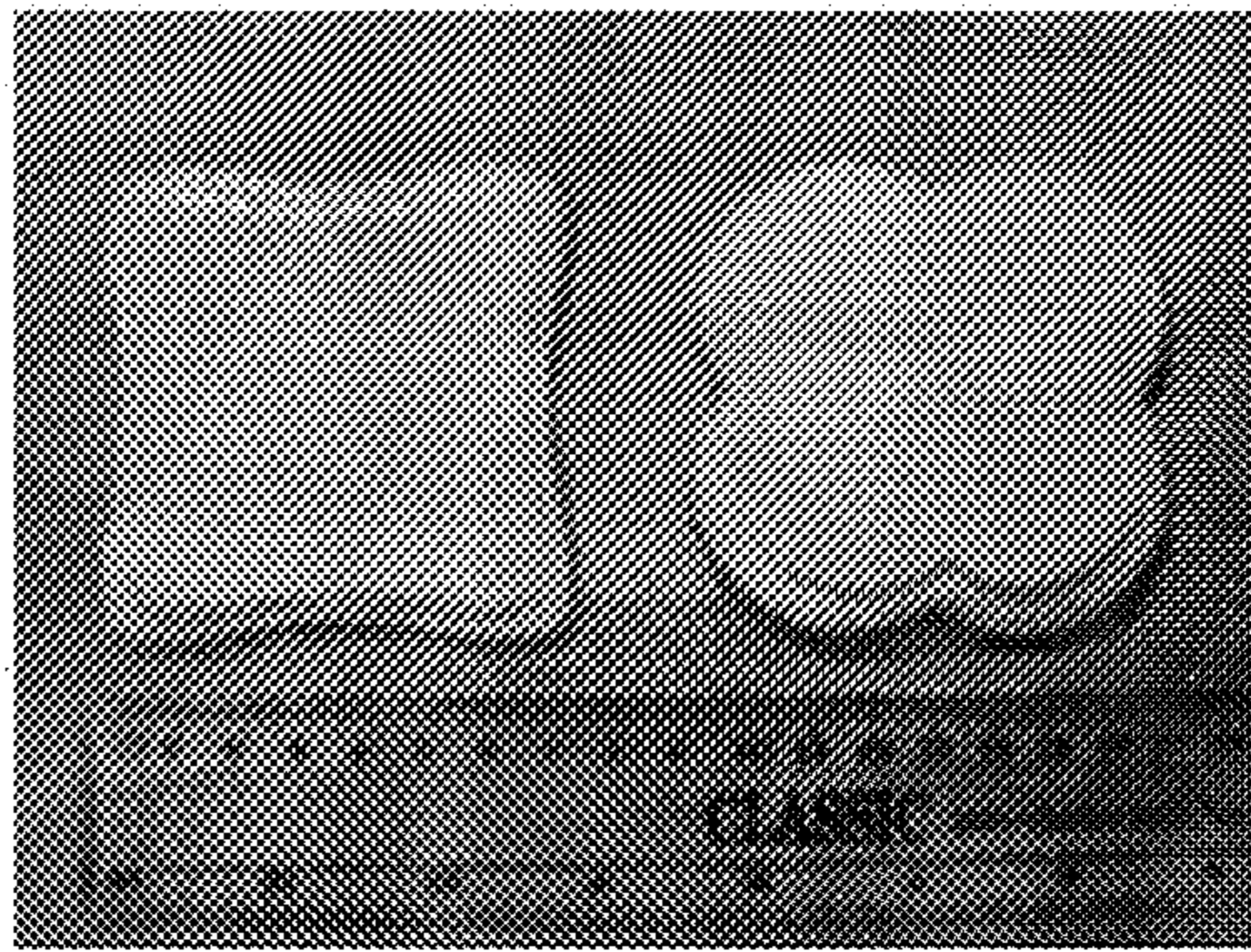
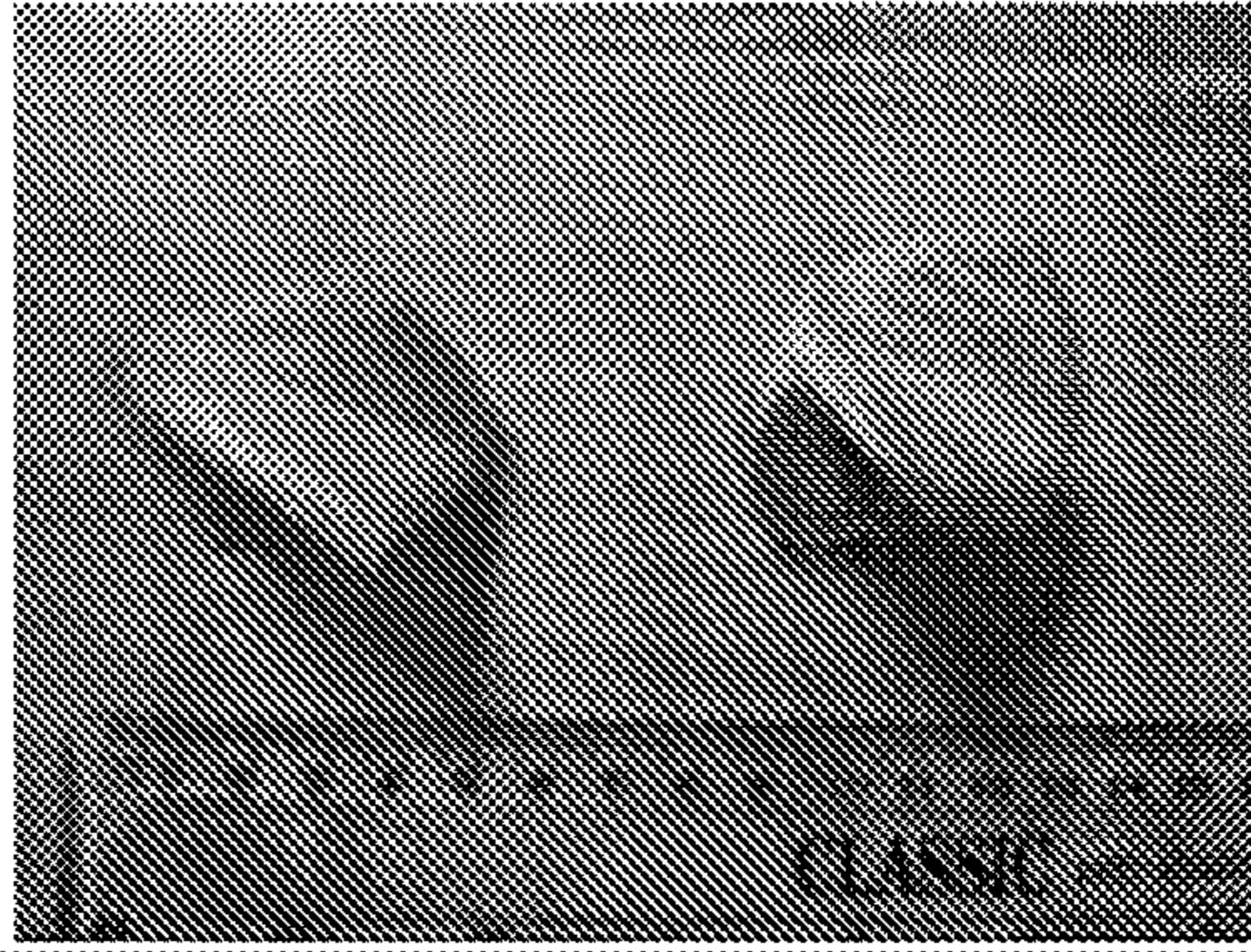


Time	Sample 6a	Sample 6b
Initial shape		
0		
5 min		
24 hours		

FIG. 6

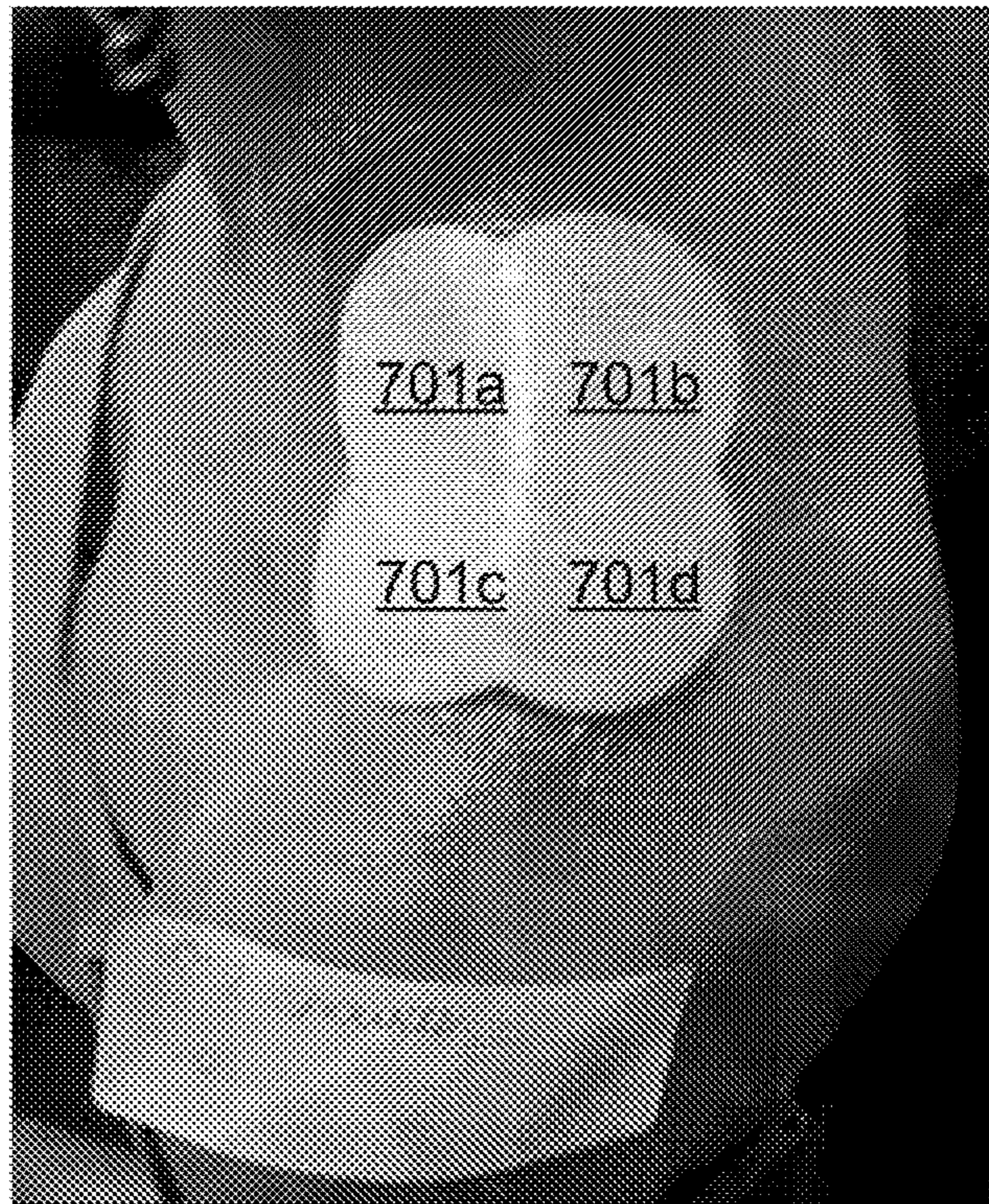


FIG. 7

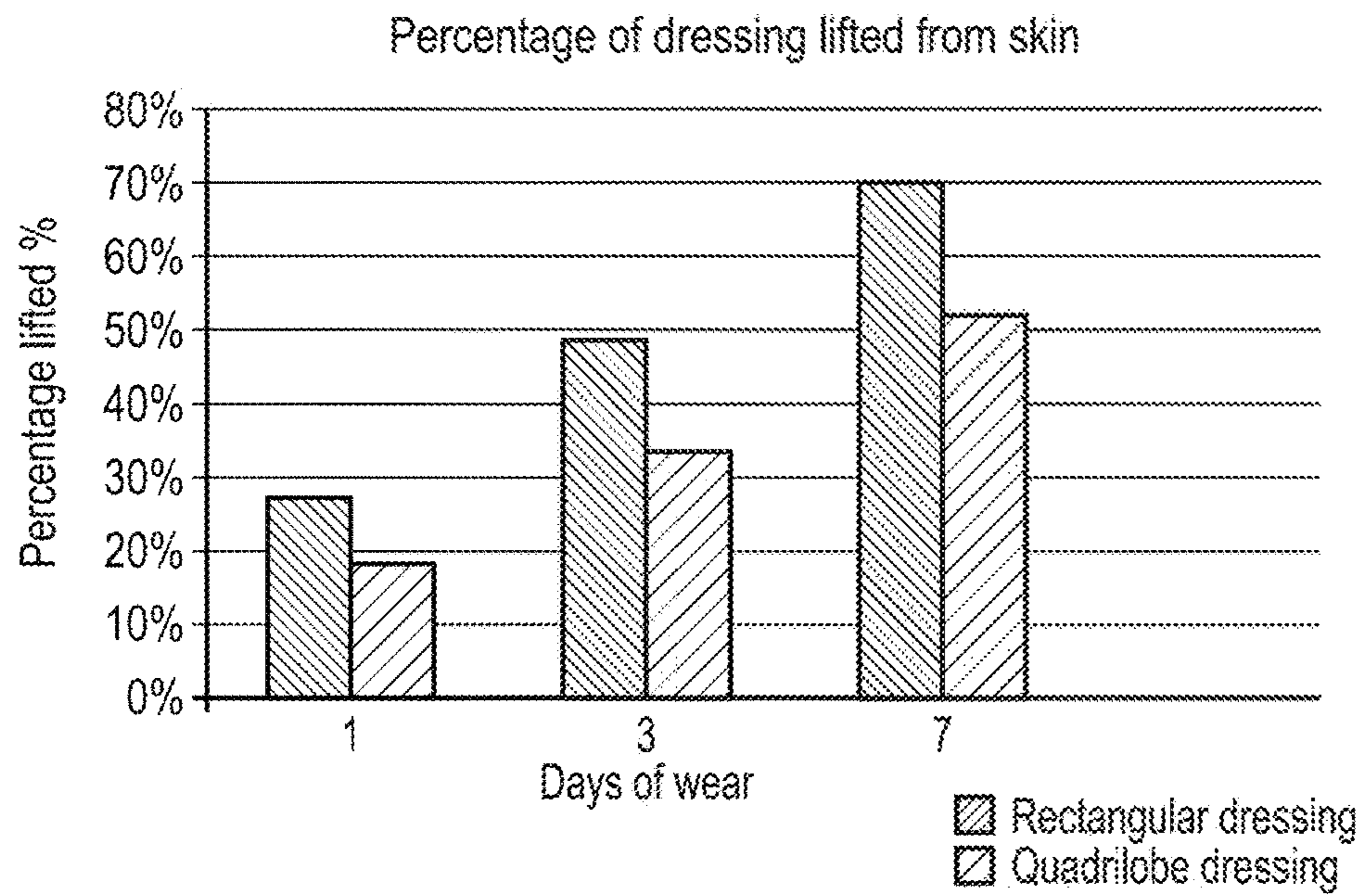


FIG. 8

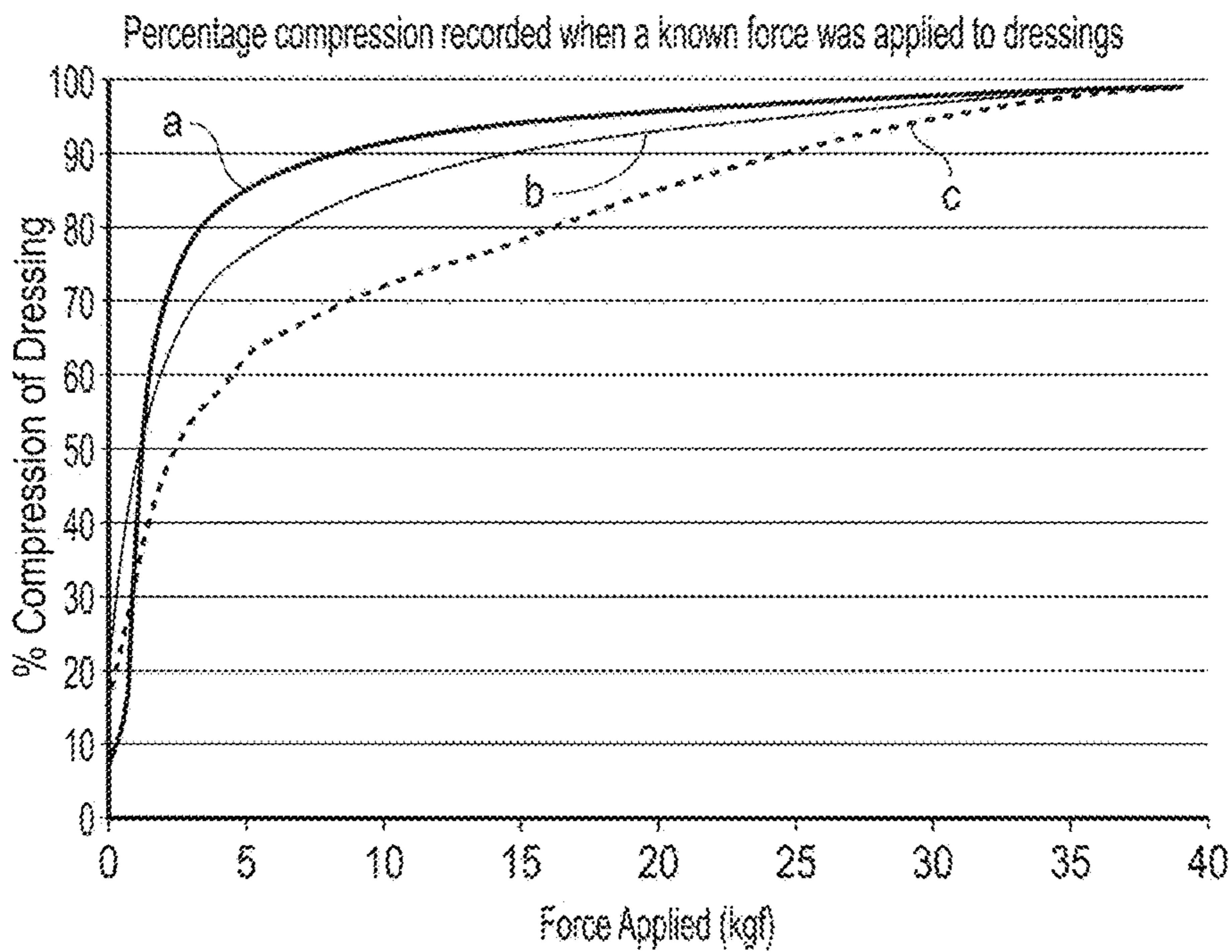


FIG. 9

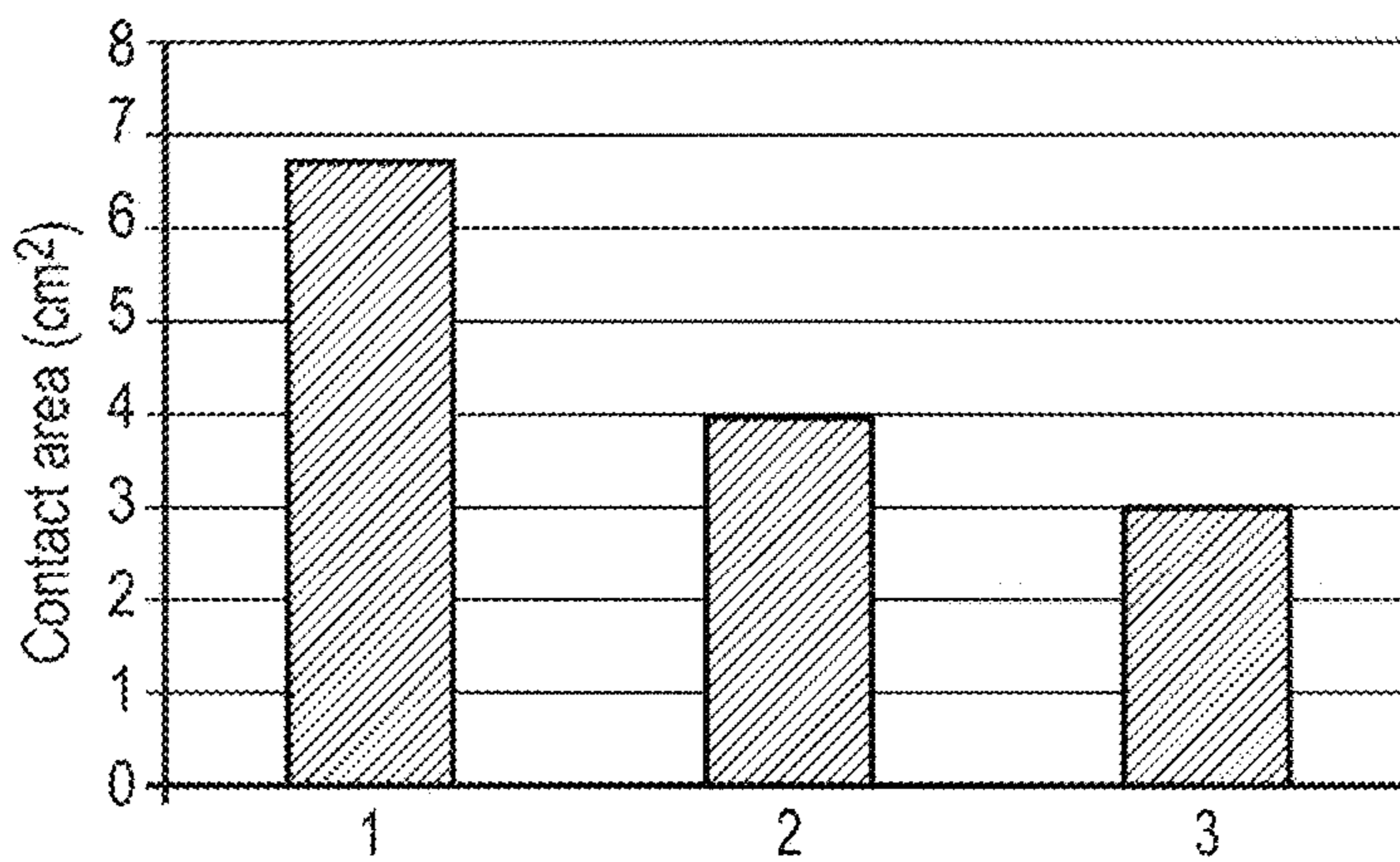
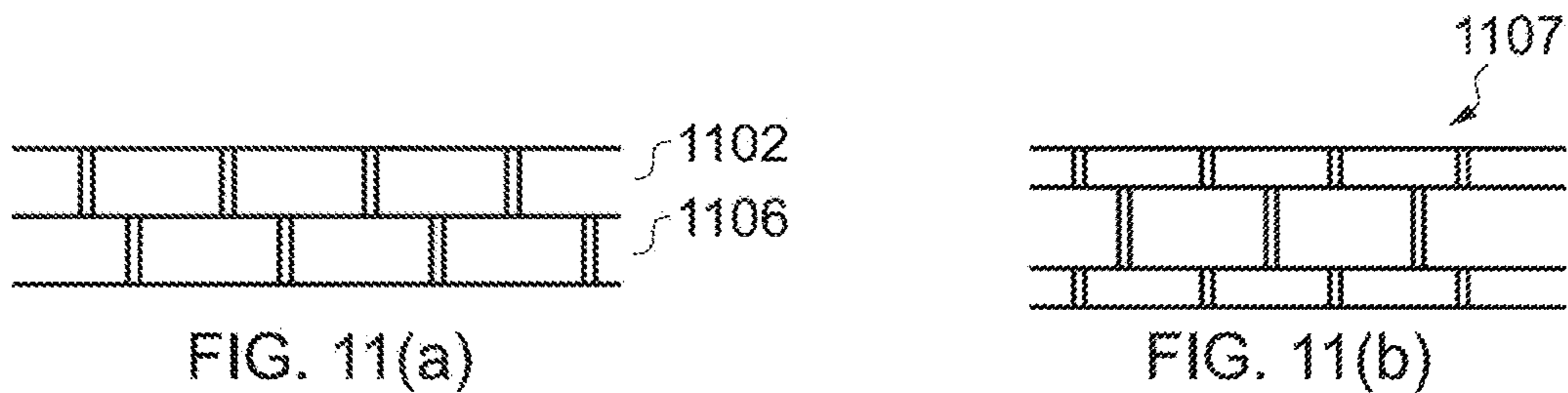


FIG. 10



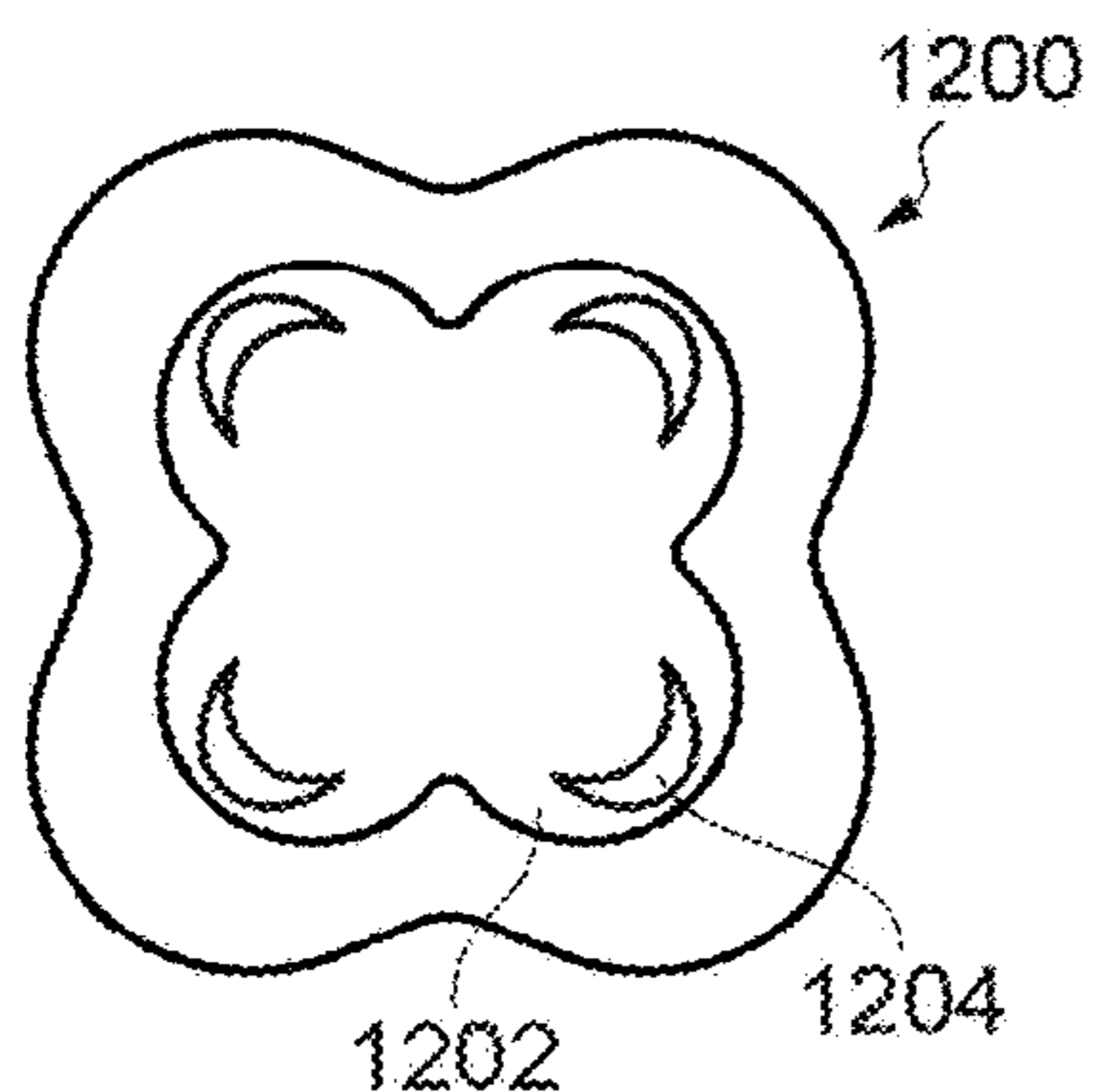


FIG. 12a

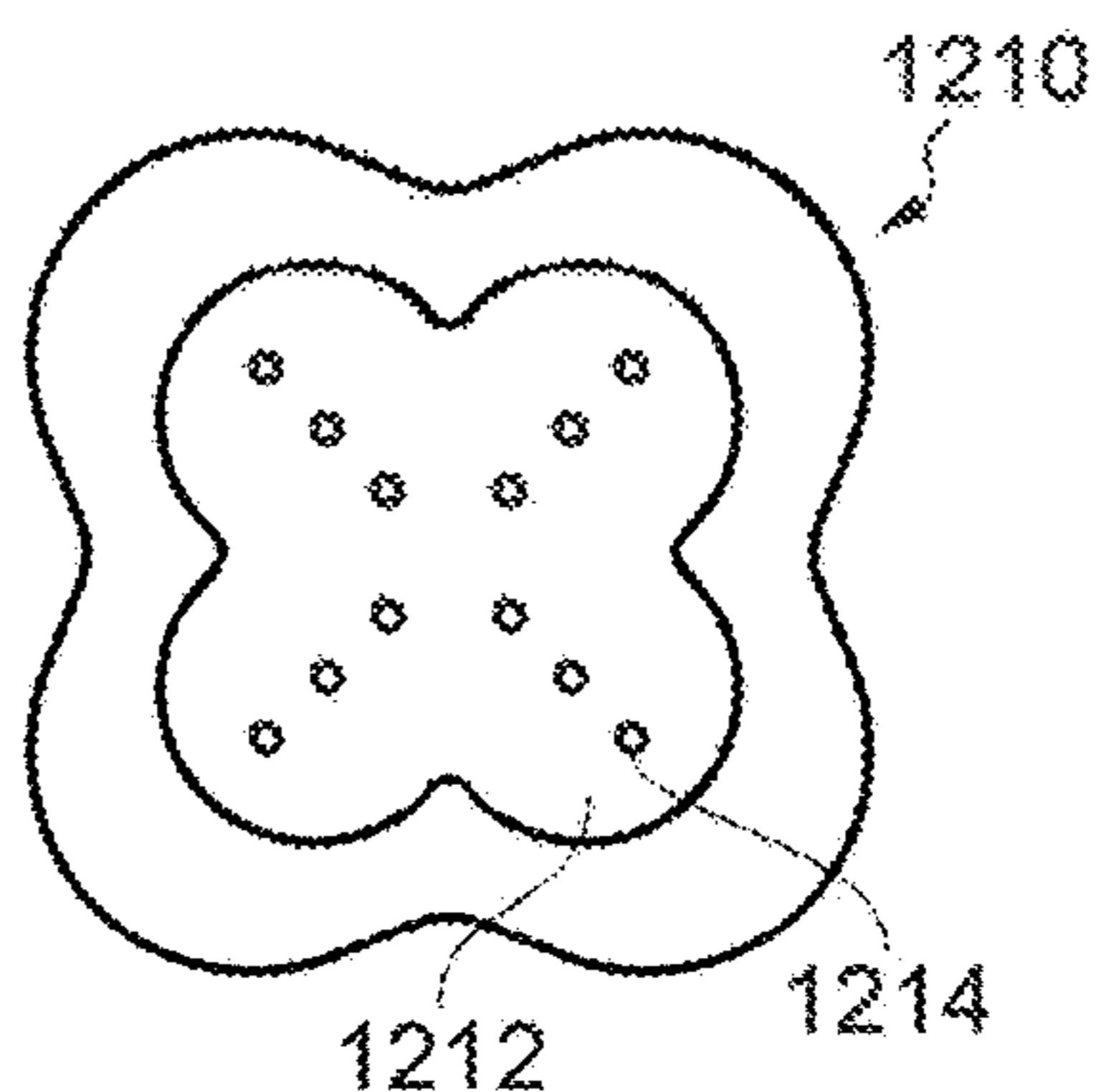


FIG. 12b

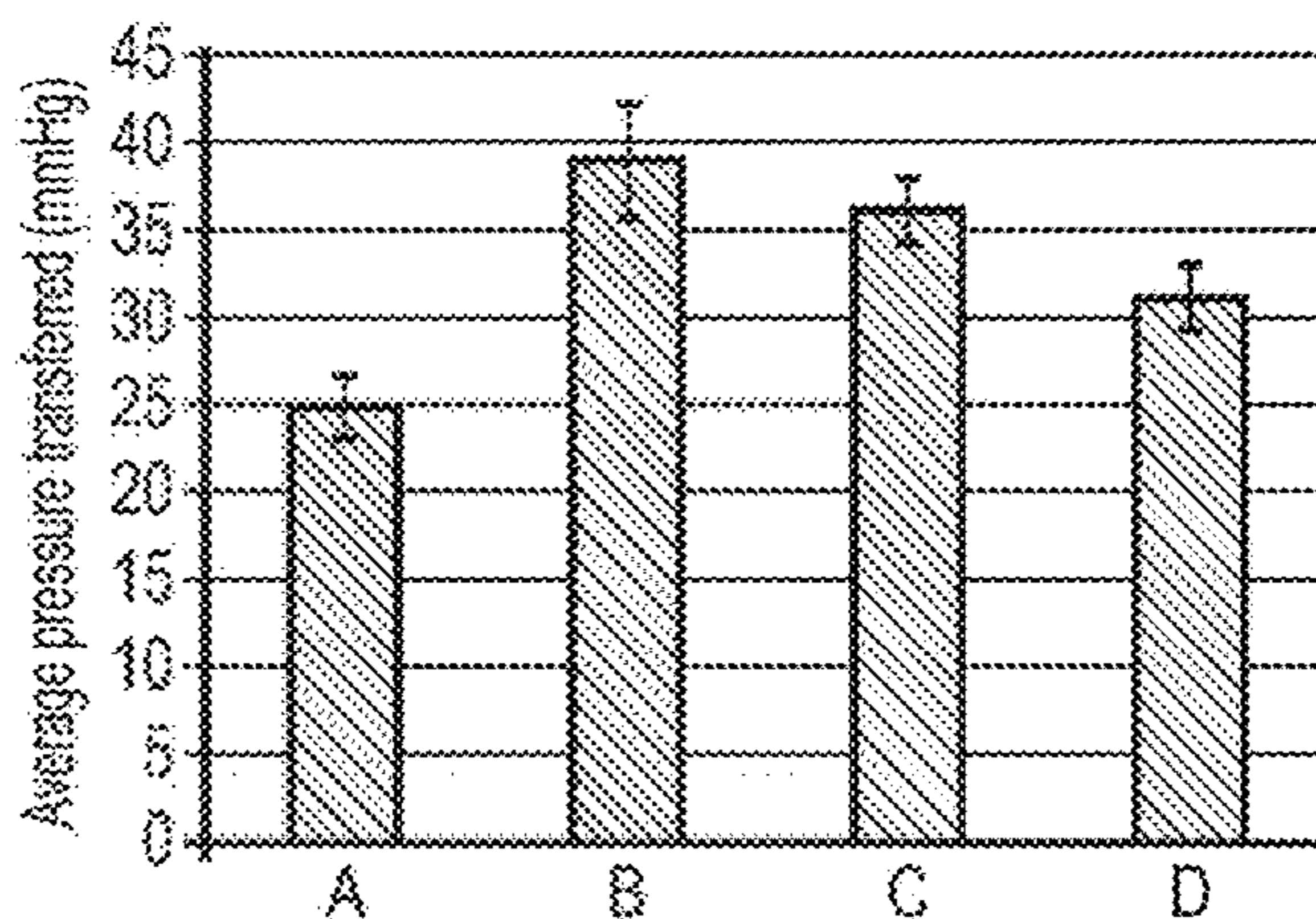


FIG. 13

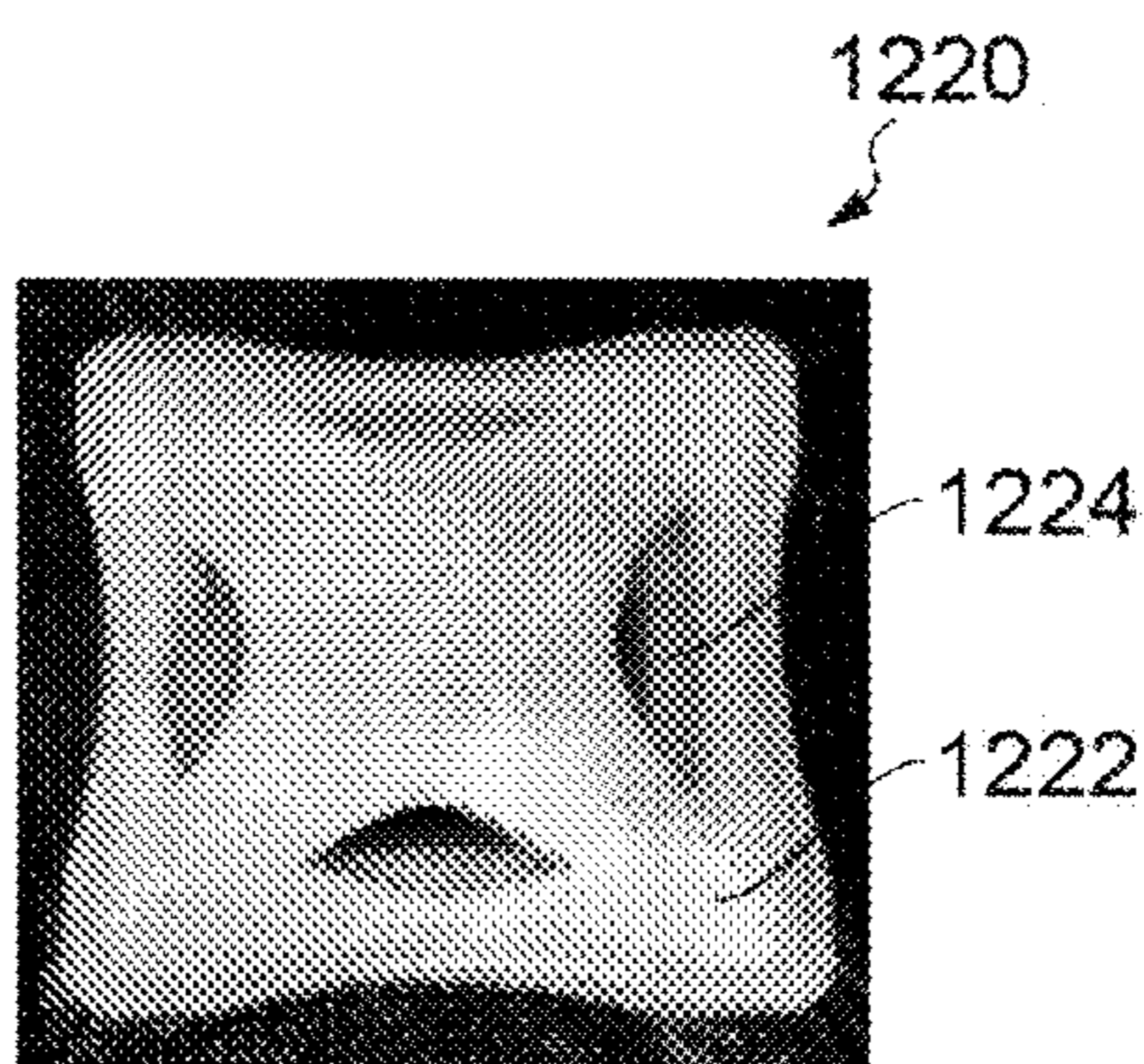


FIG. 12c

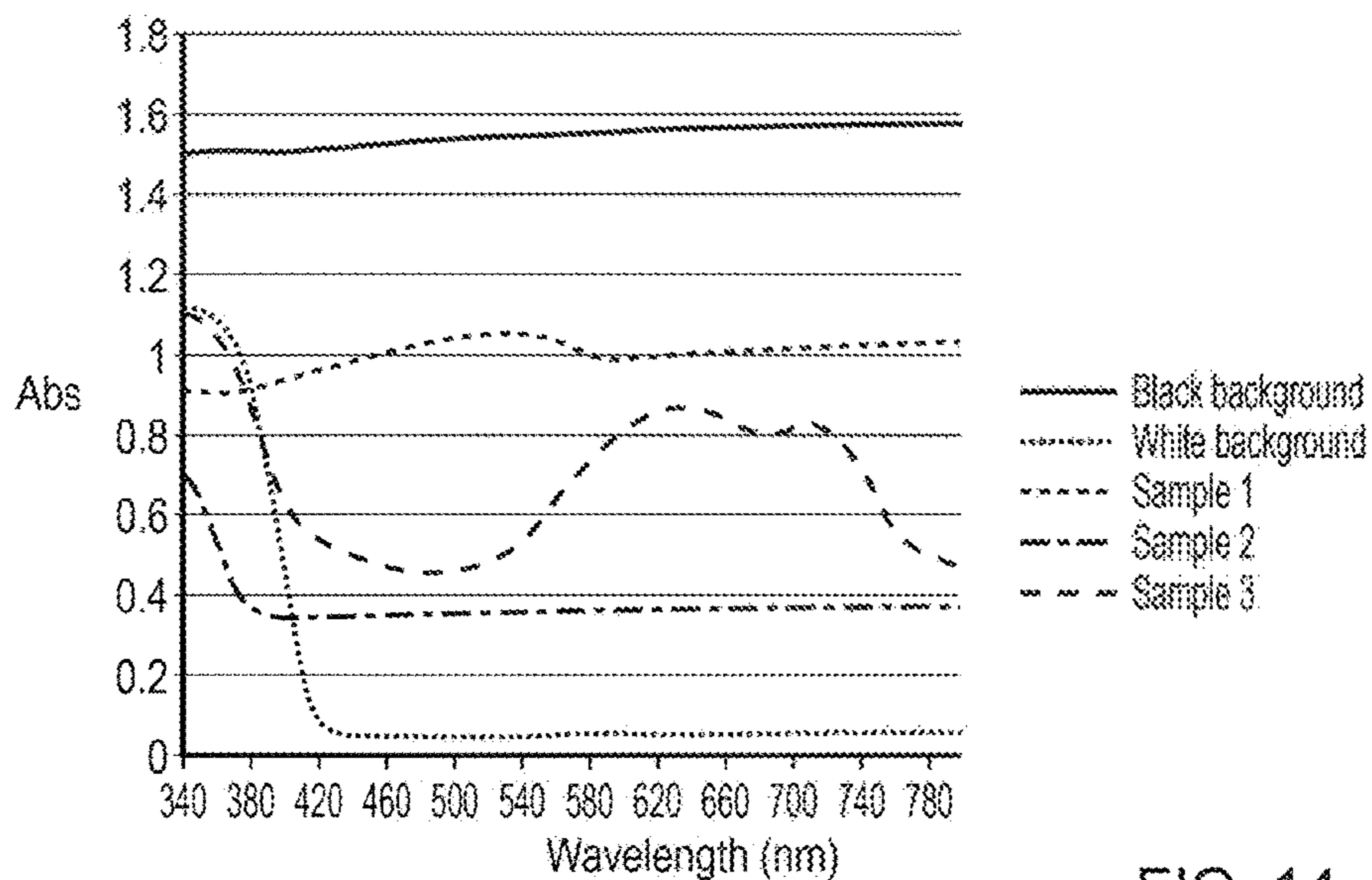


FIG. 14

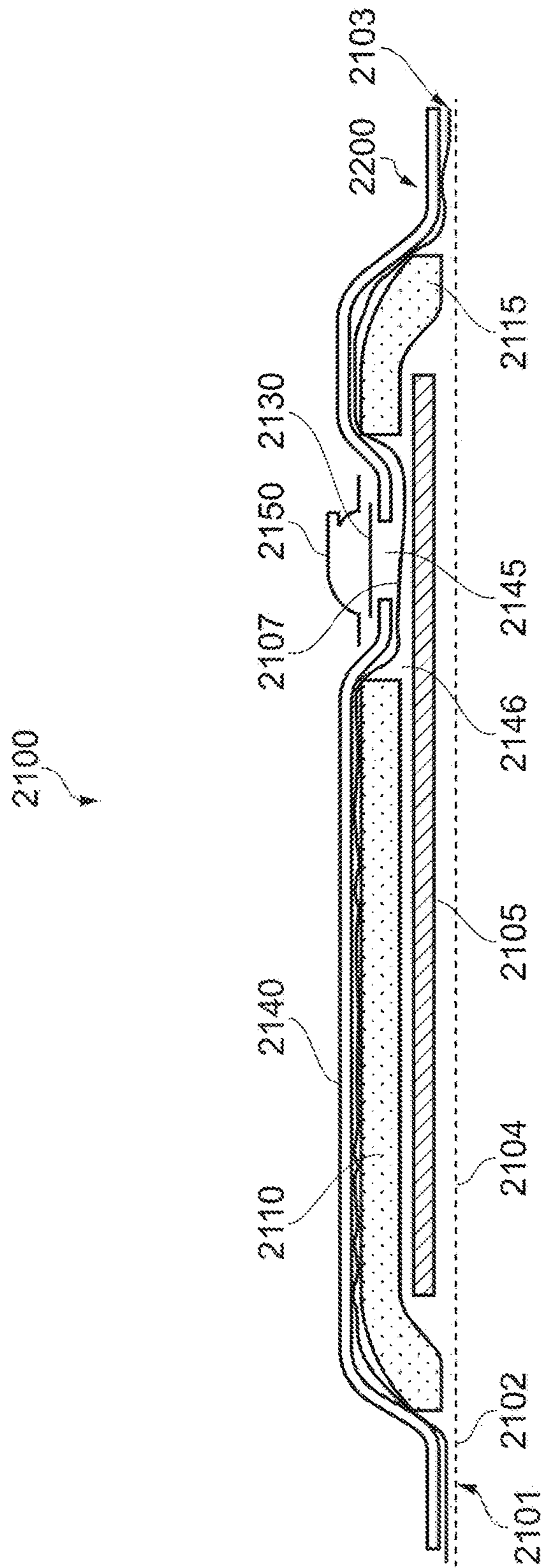


FIG. 15A

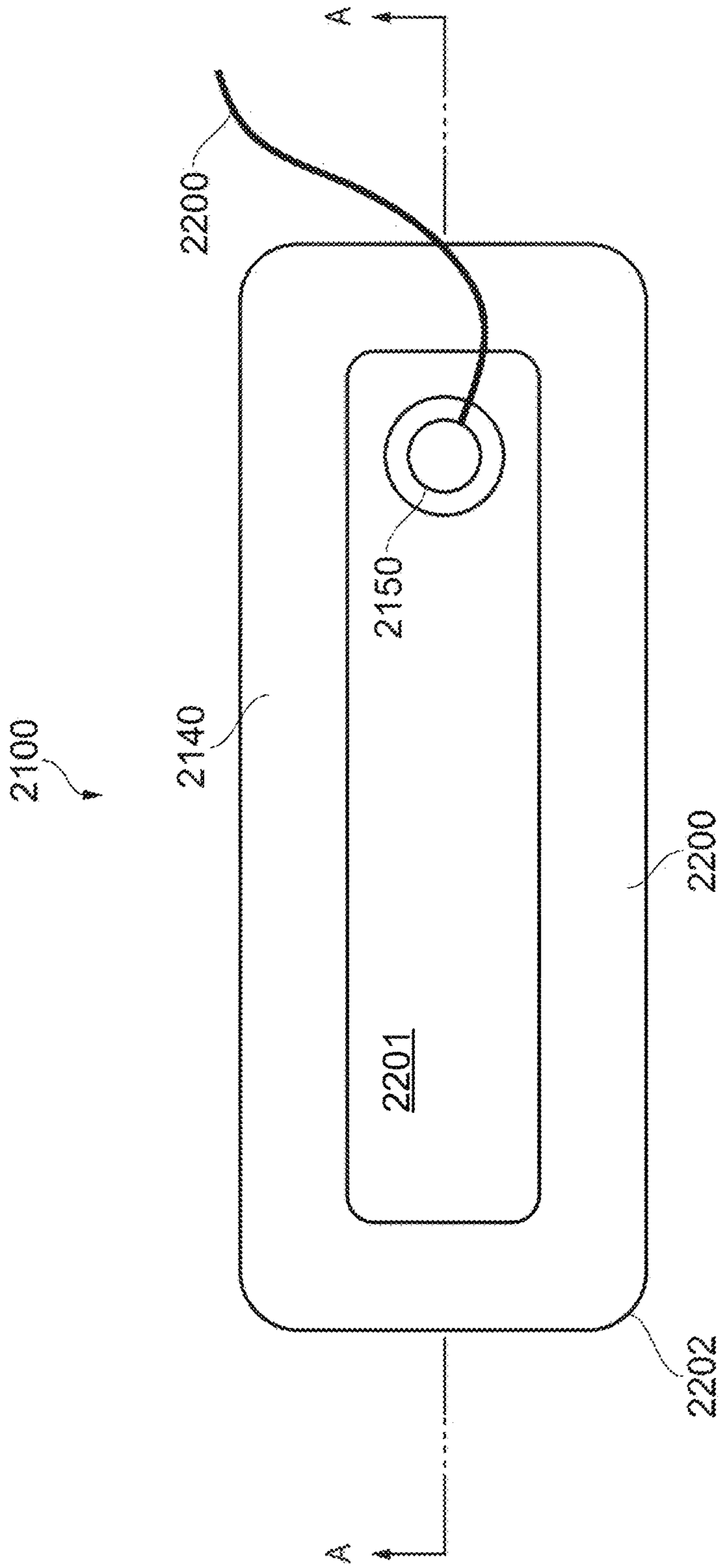


FIG. 16

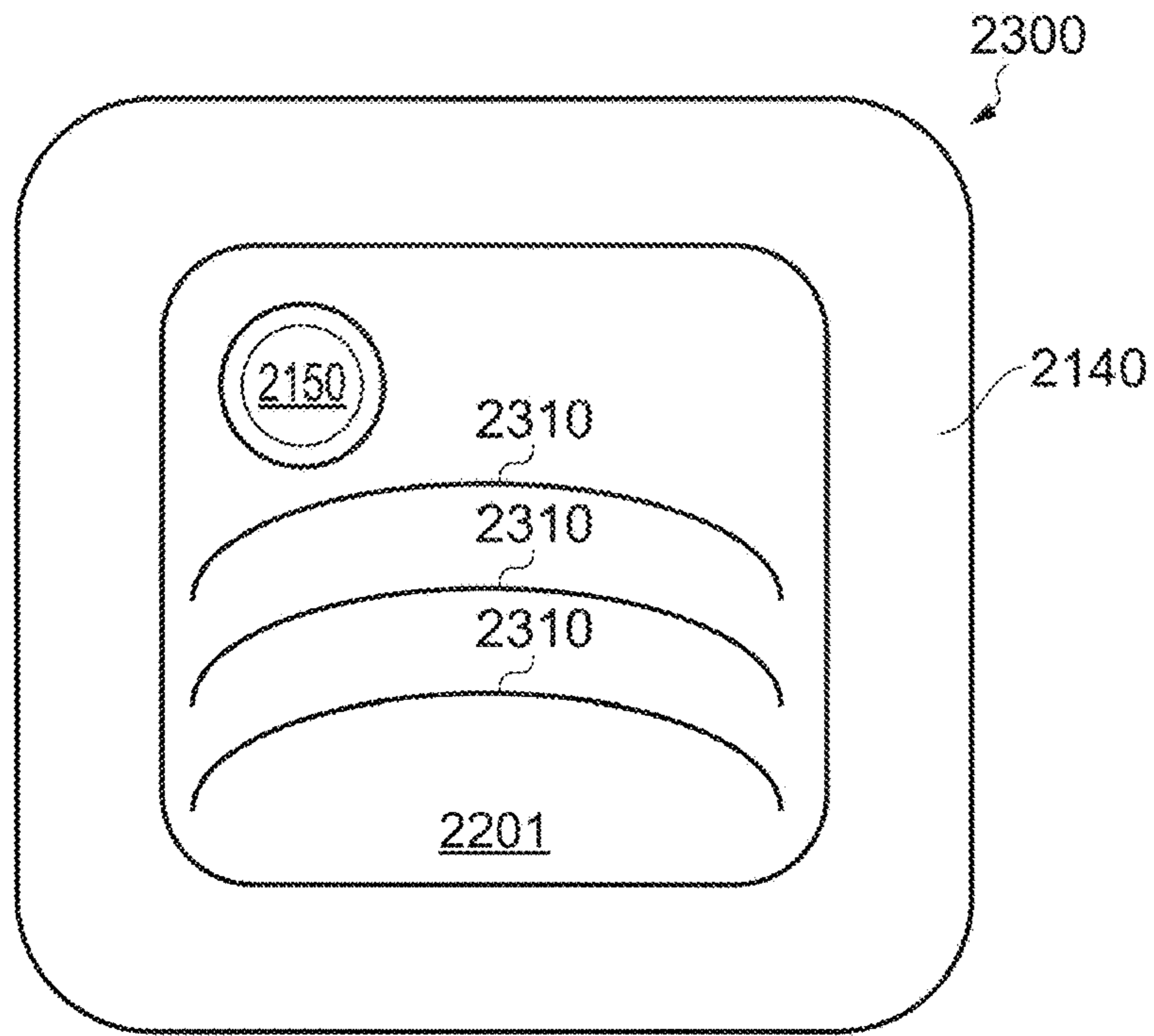


FIG. 17

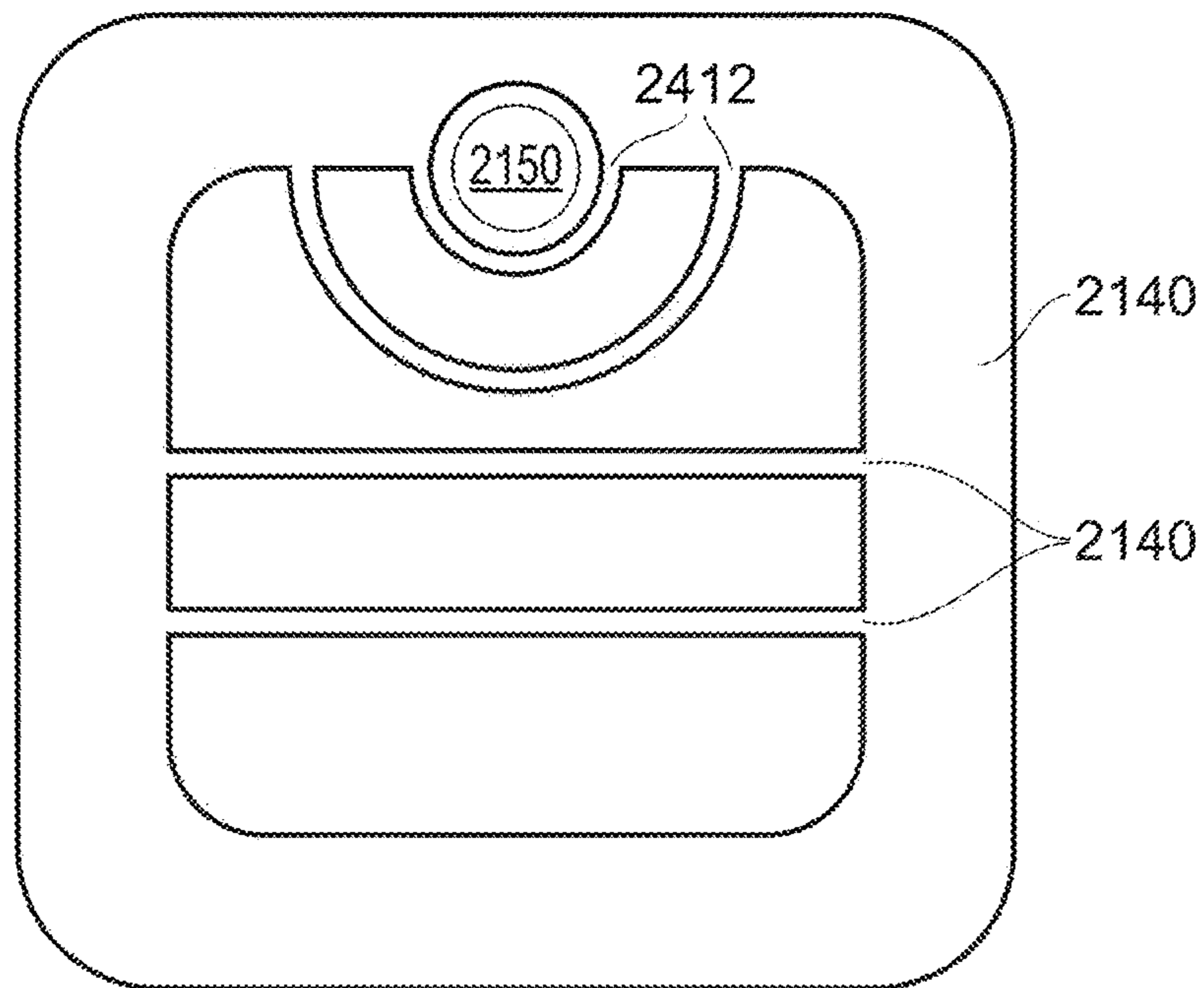


FIG. 18

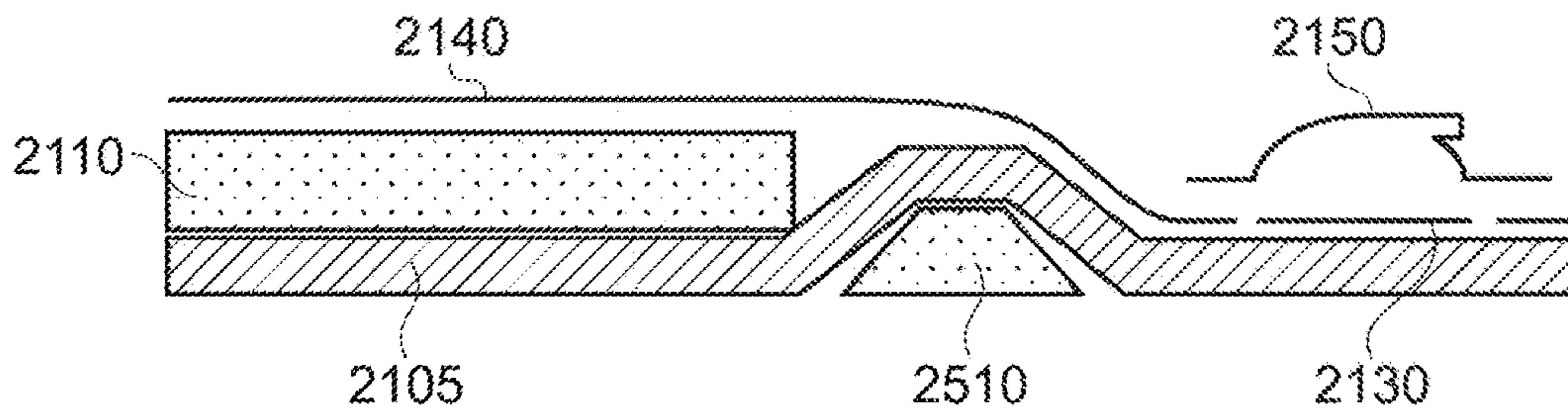


FIG. 19

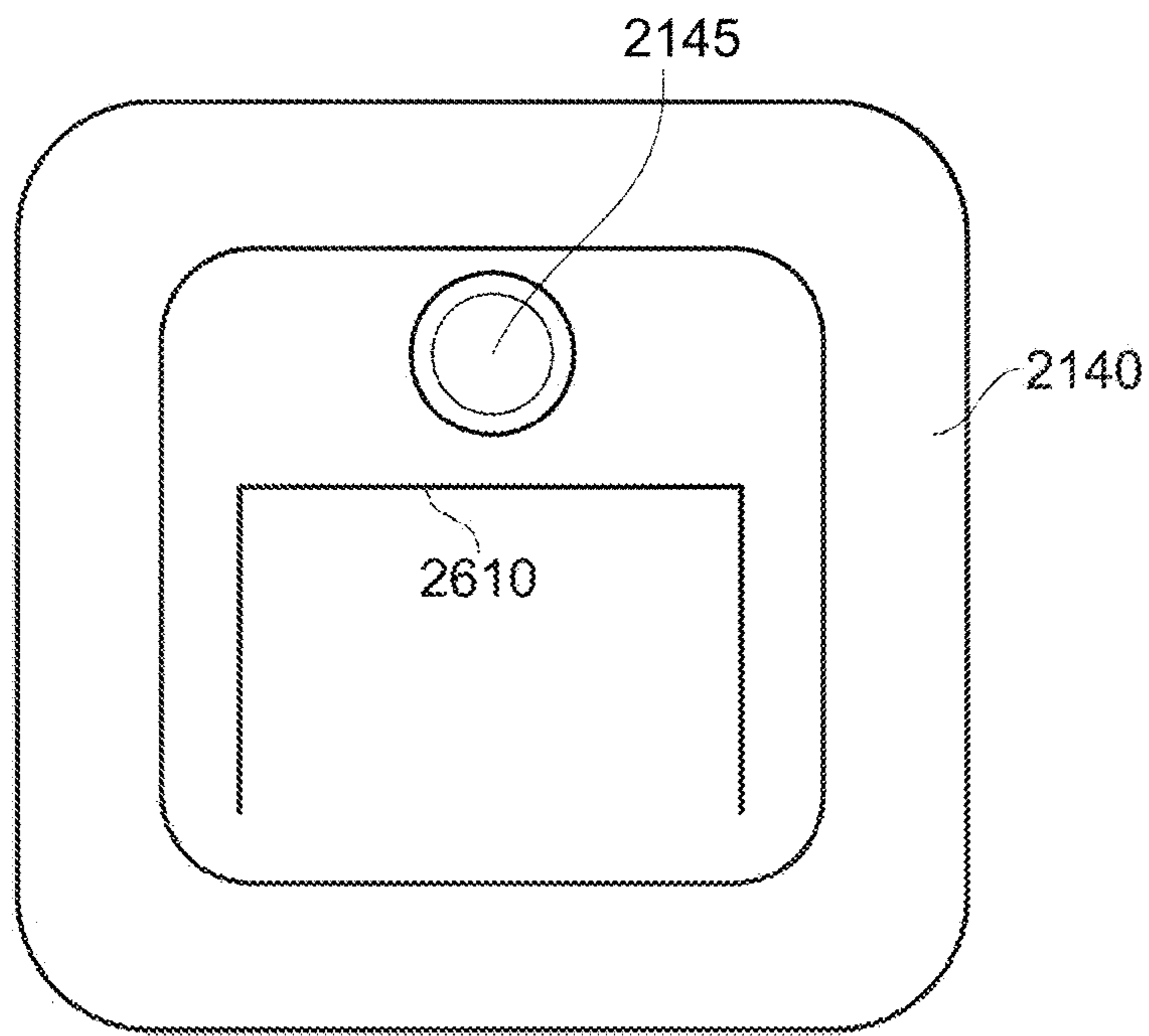


FIG. 20

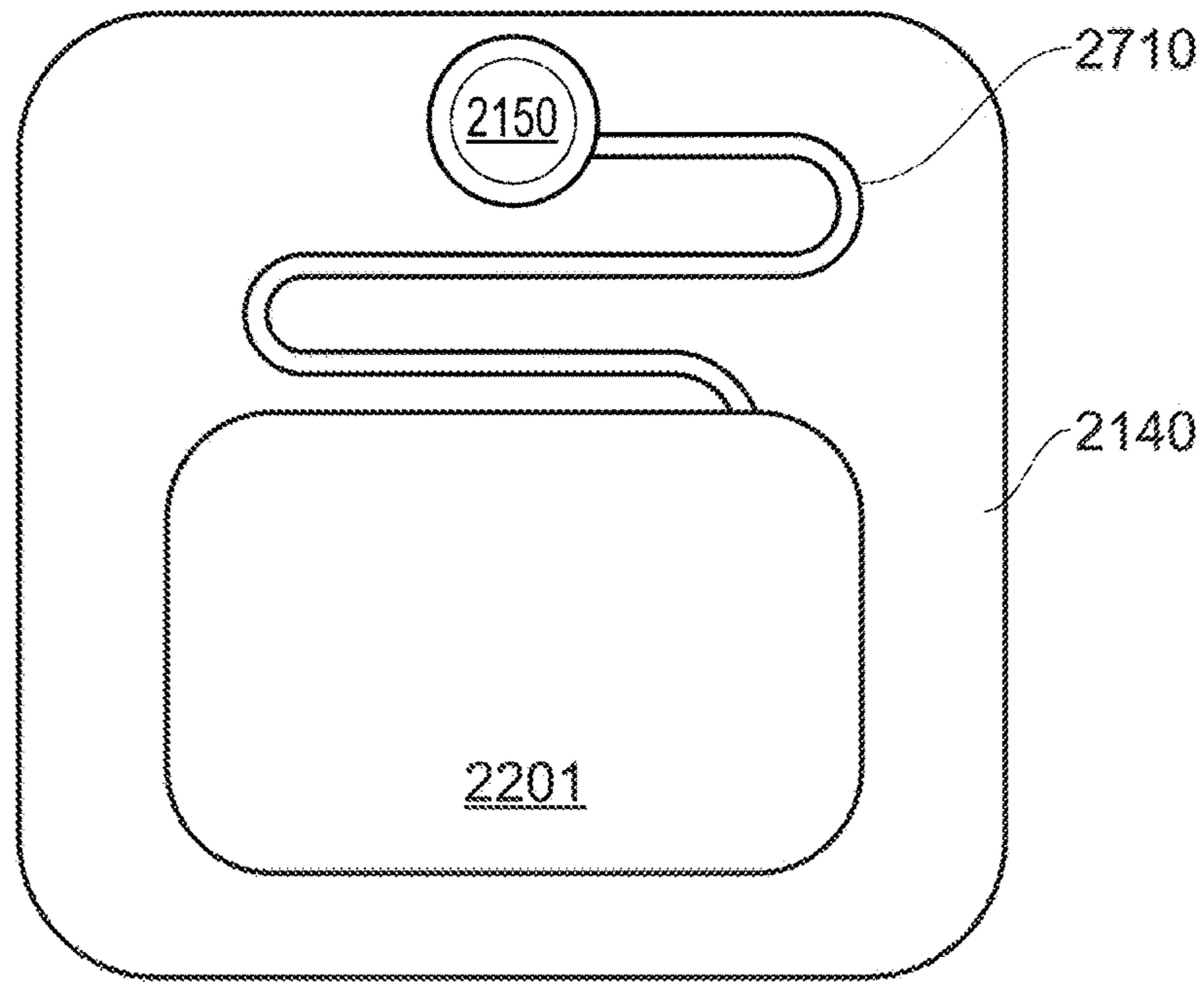


FIG. 21

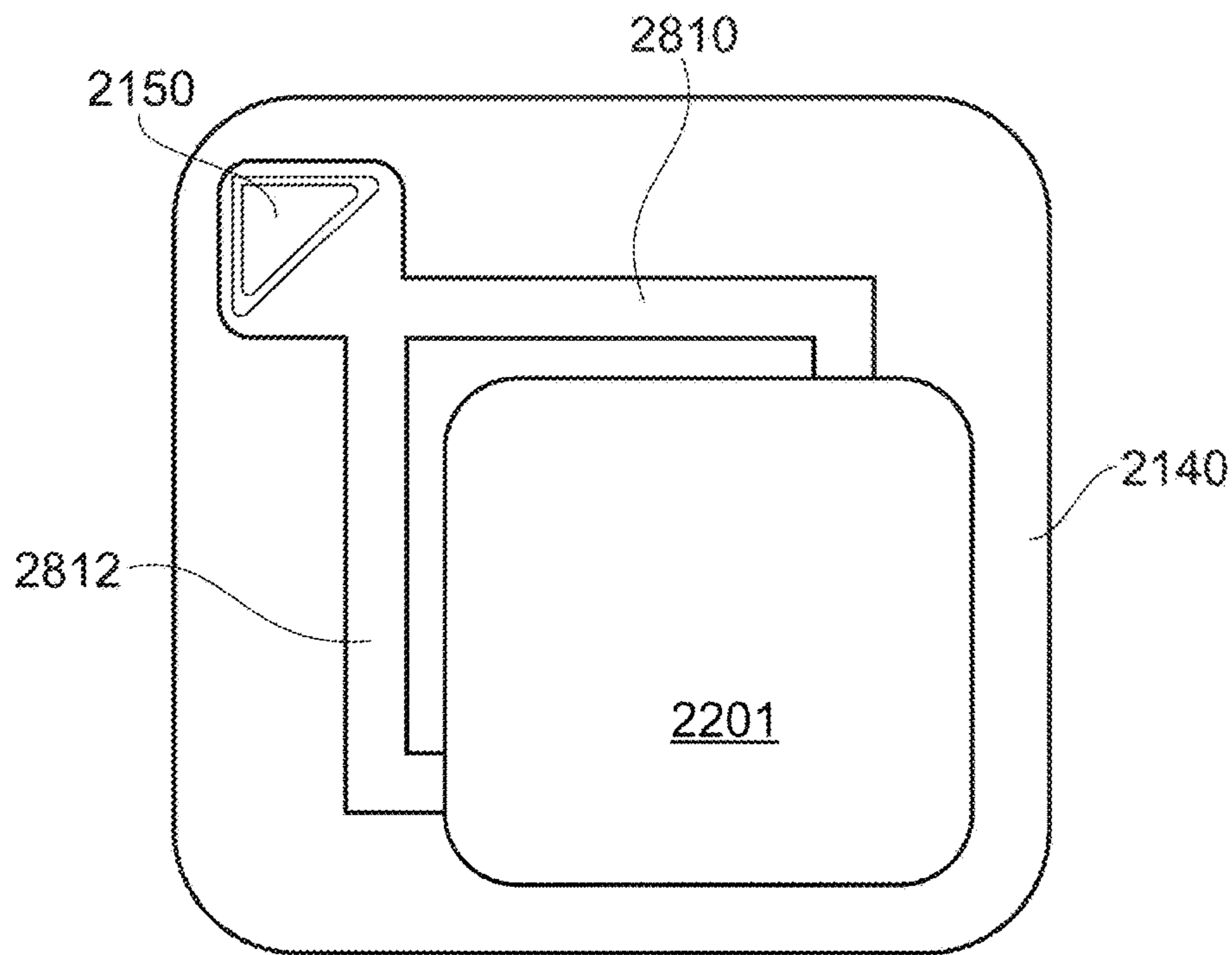


FIG. 22

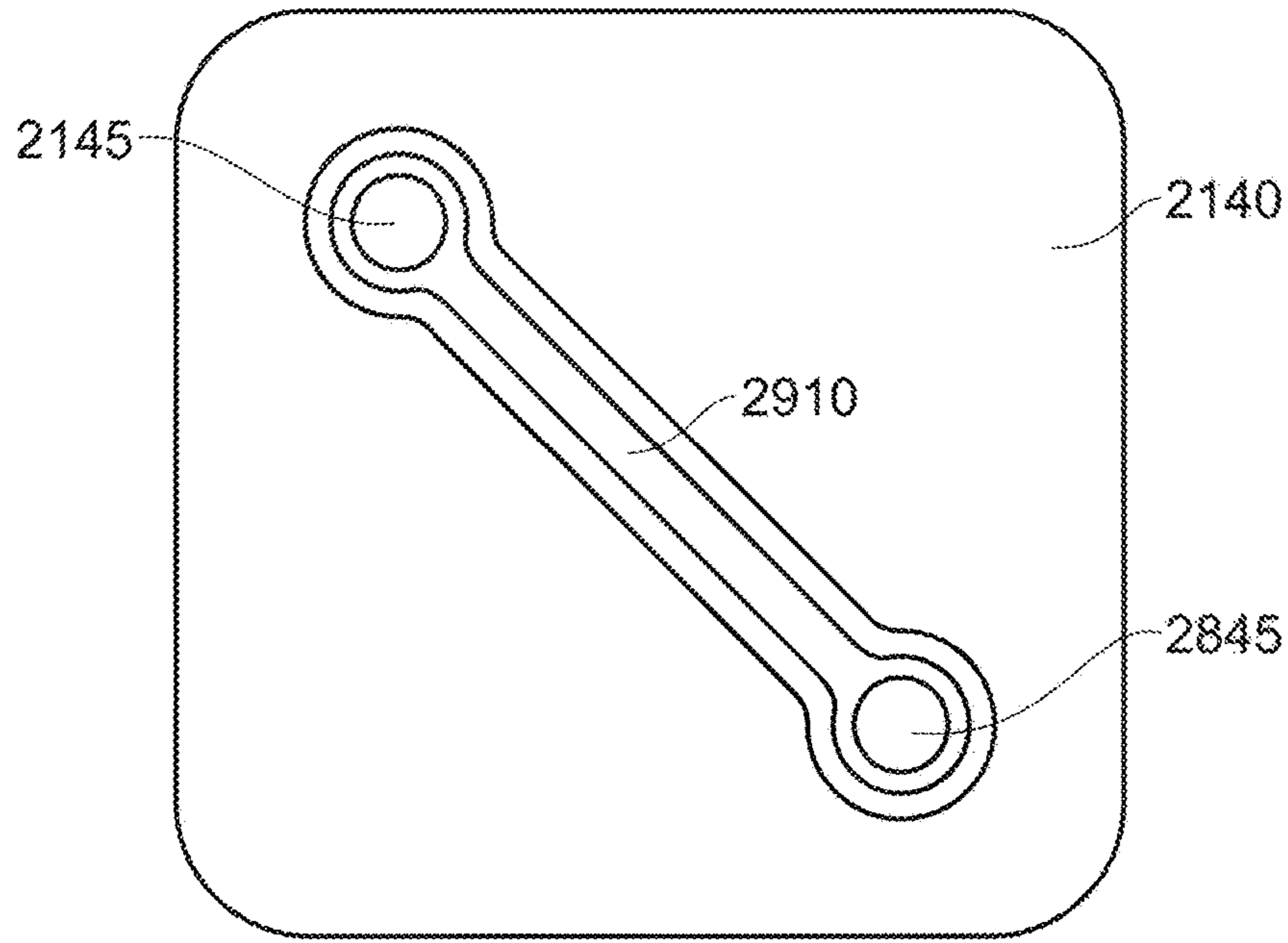


FIG. 23

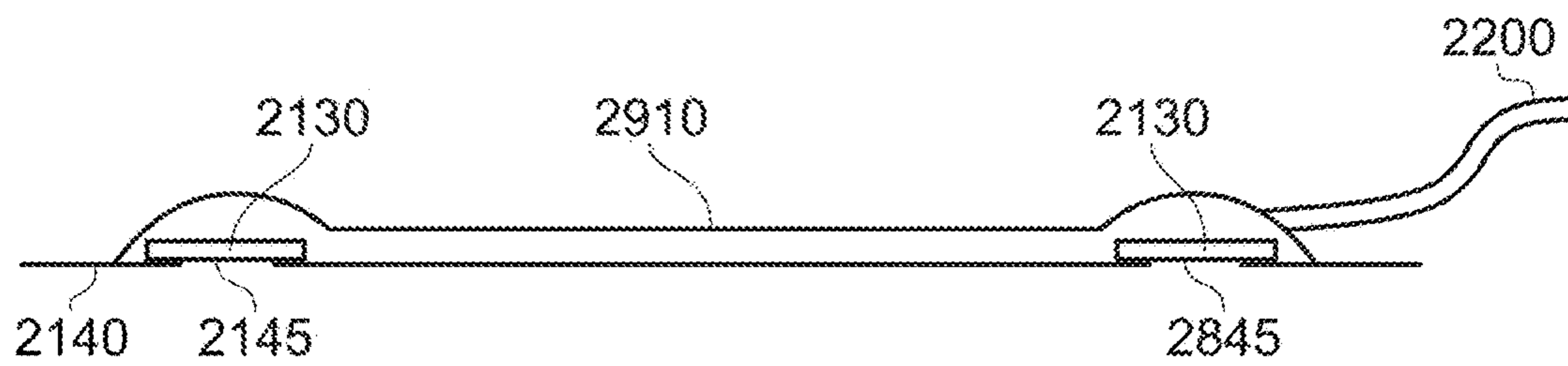


FIG. 24

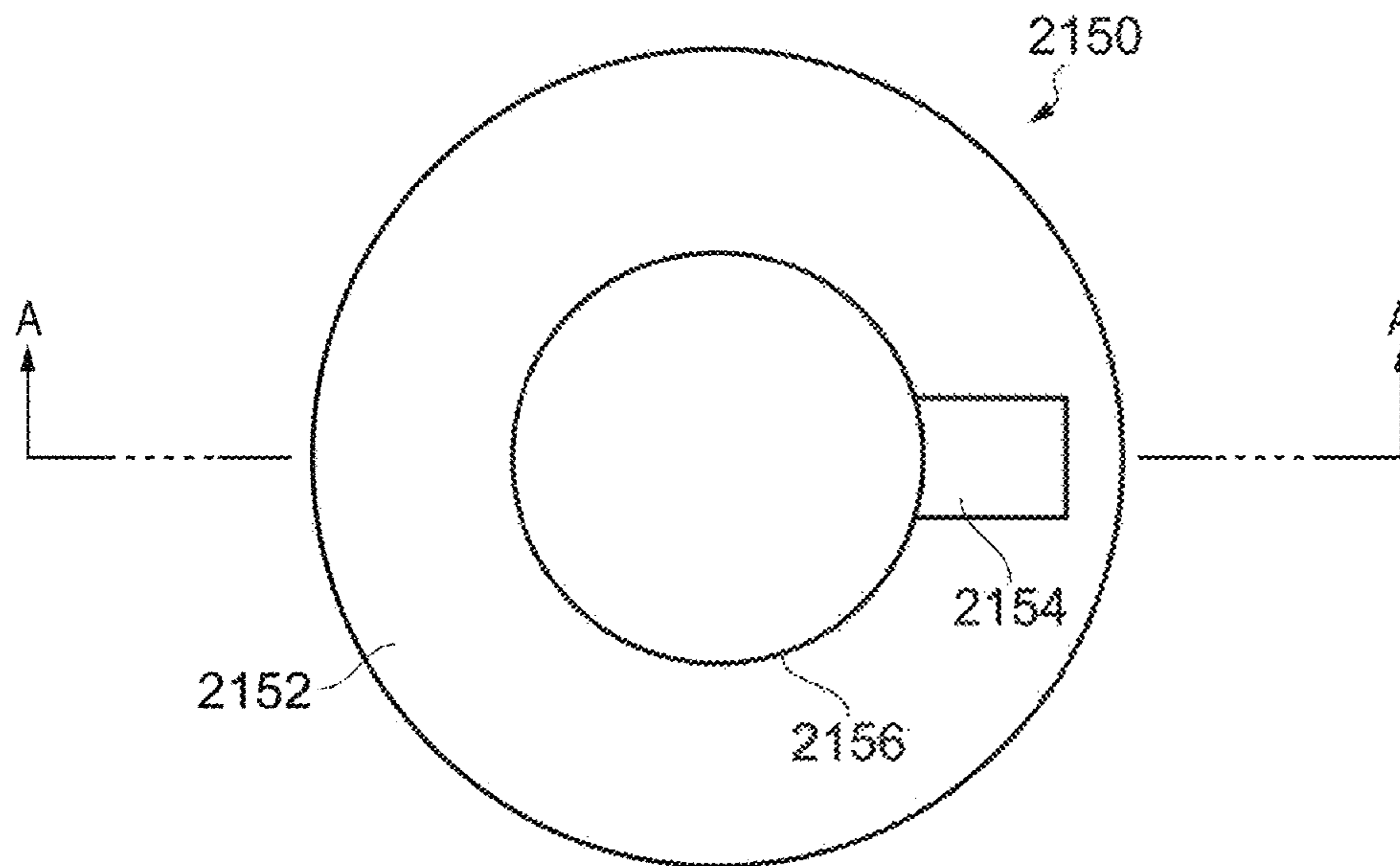


FIG. 25

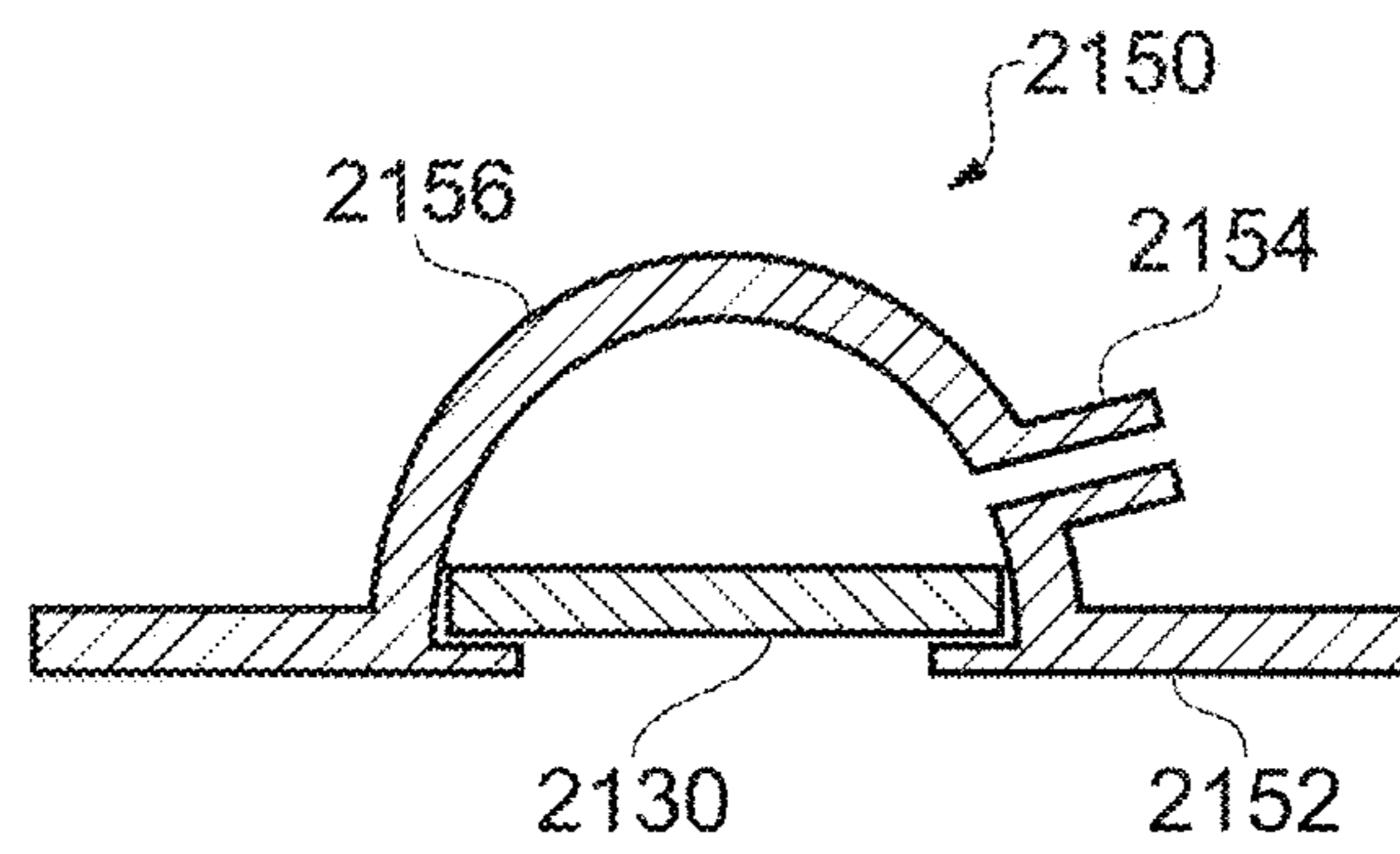


FIG. 26

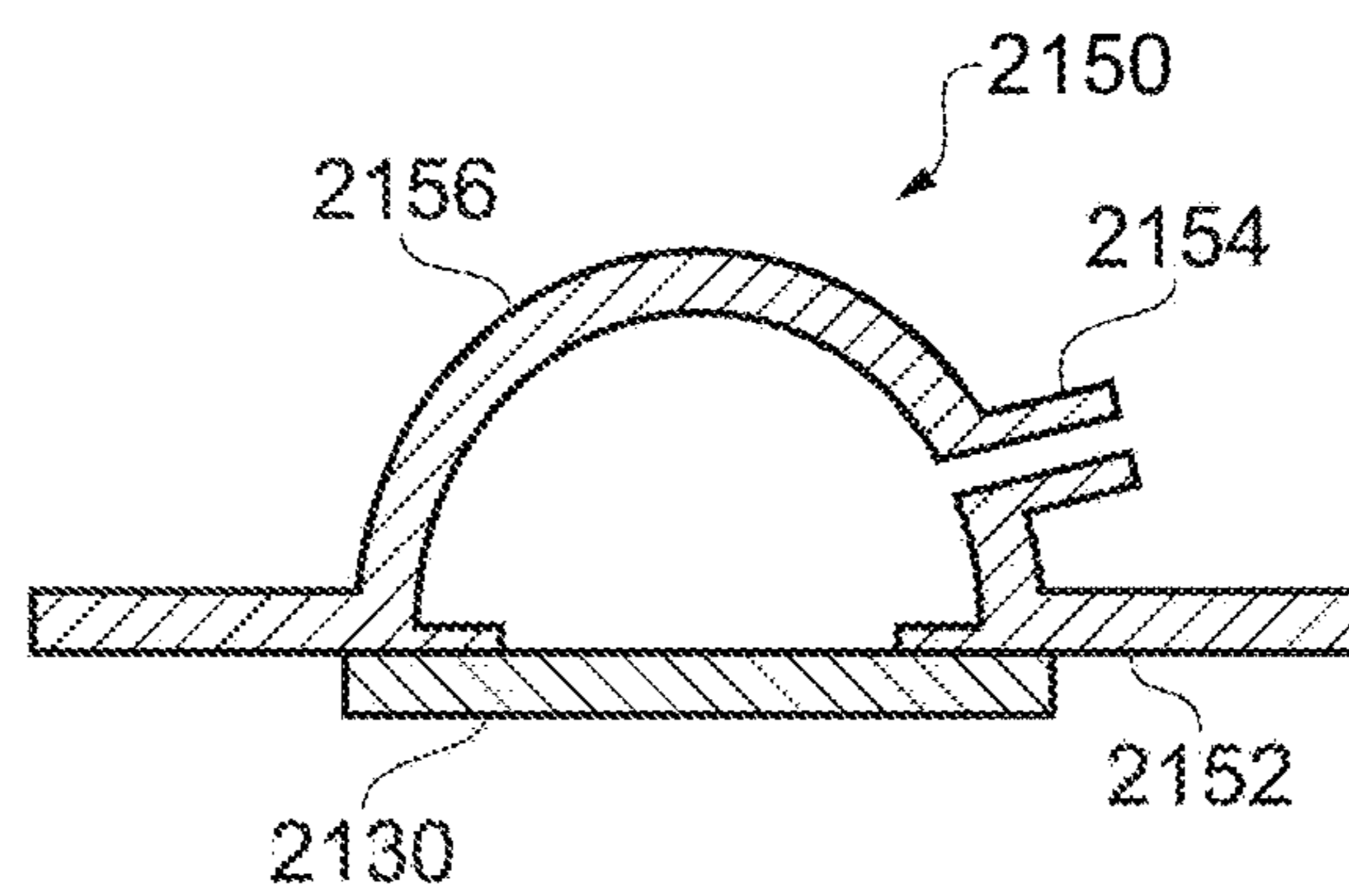


FIG. 27

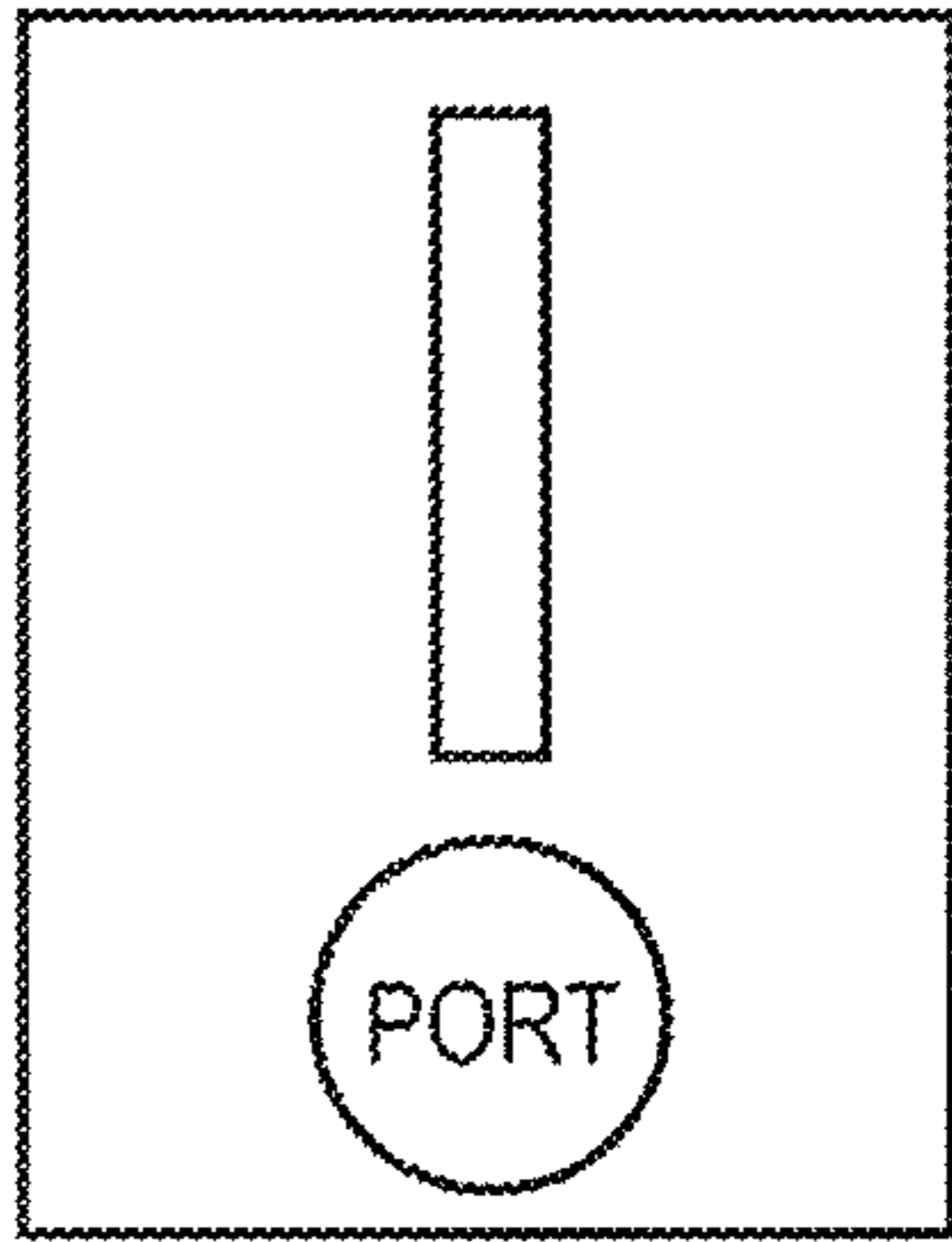


FIG. 28A

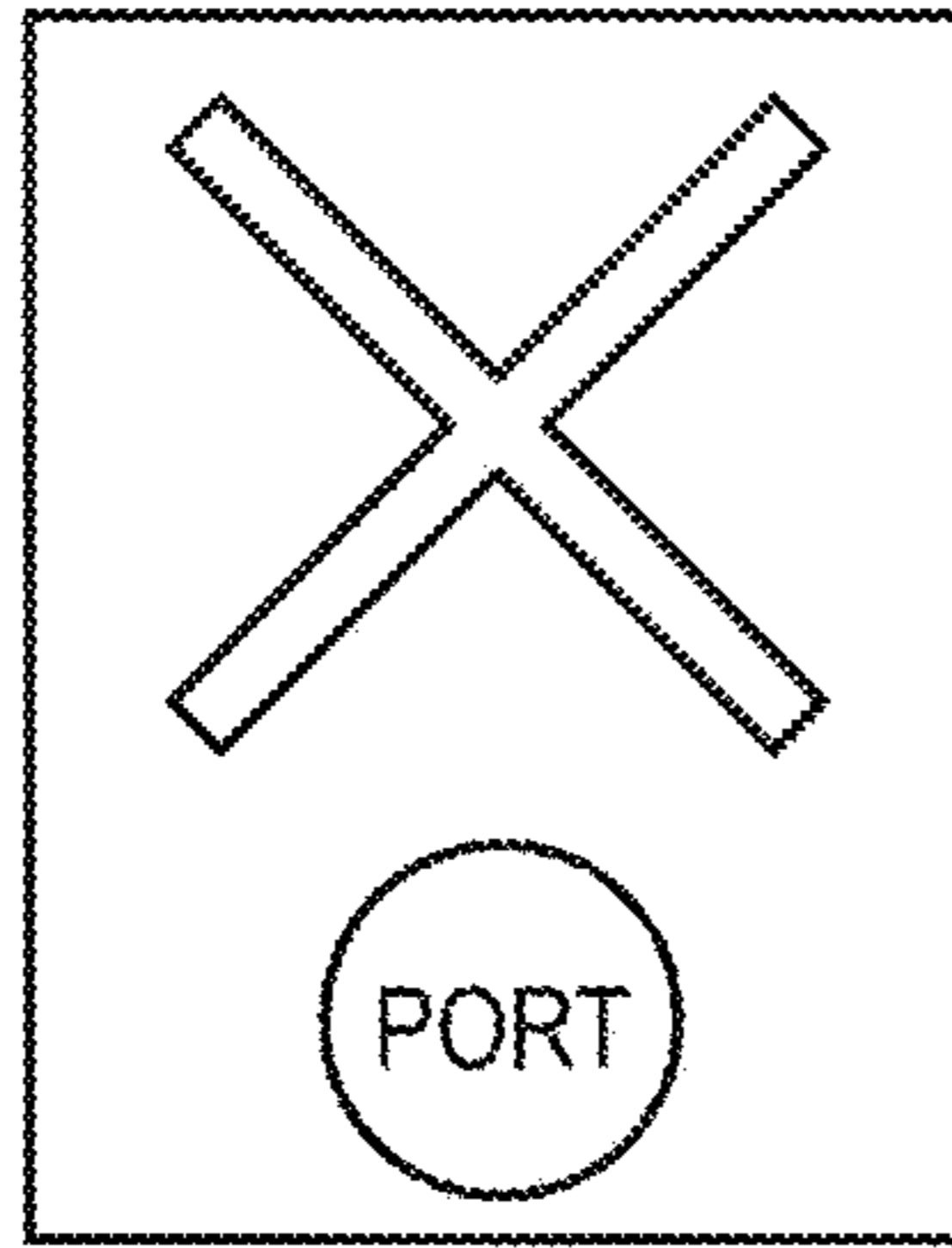


FIG. 28B

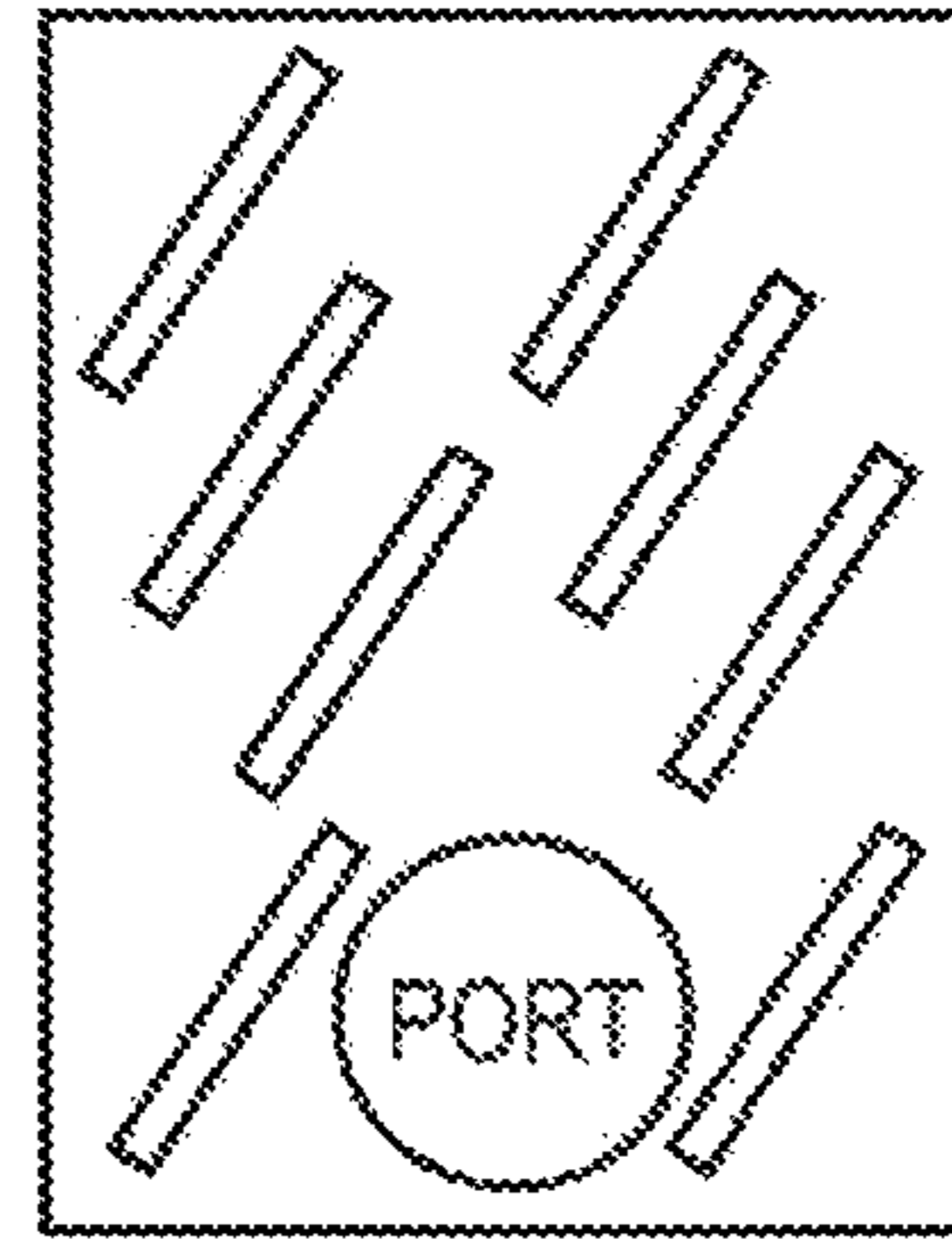


FIG. 28C

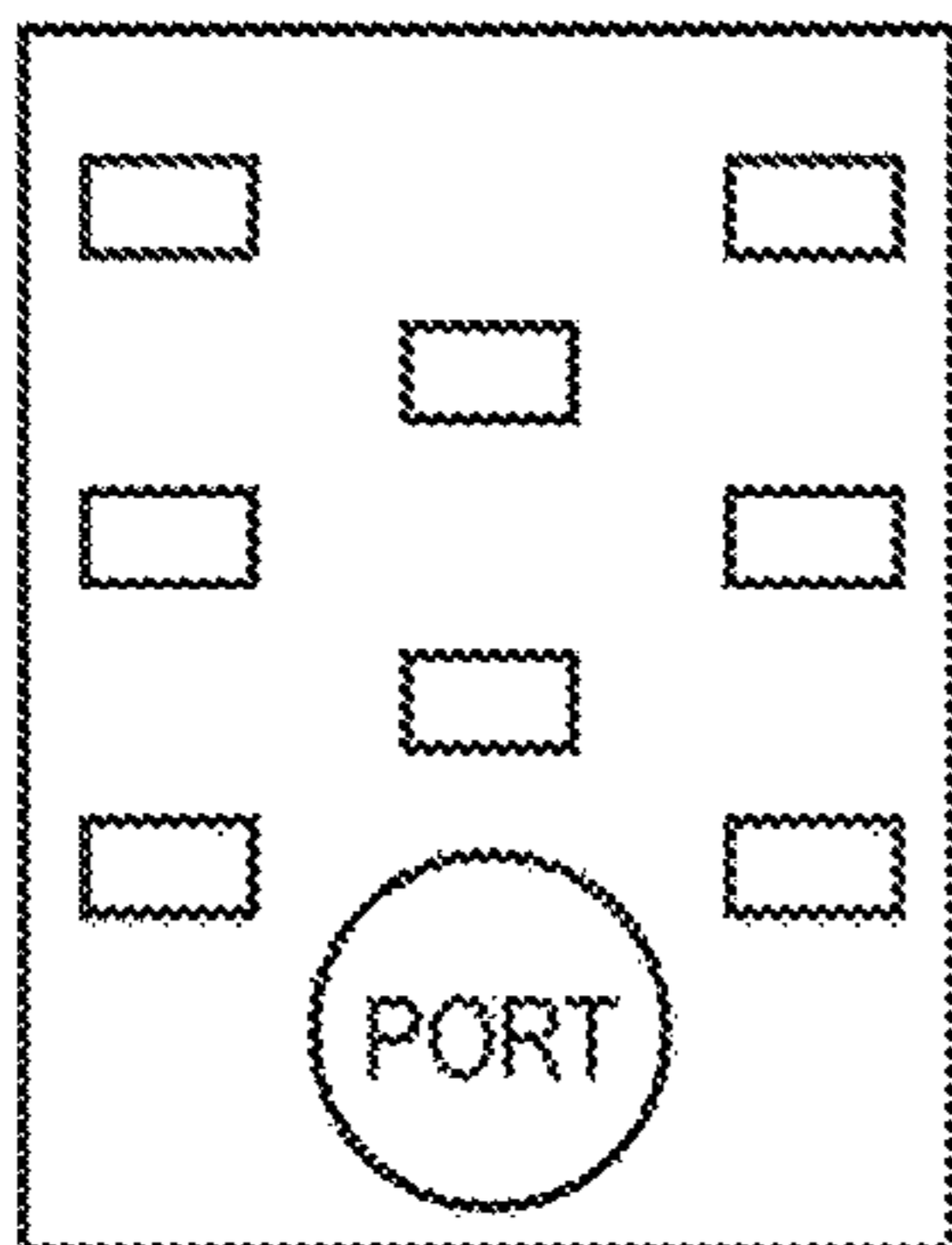


FIG. 28D

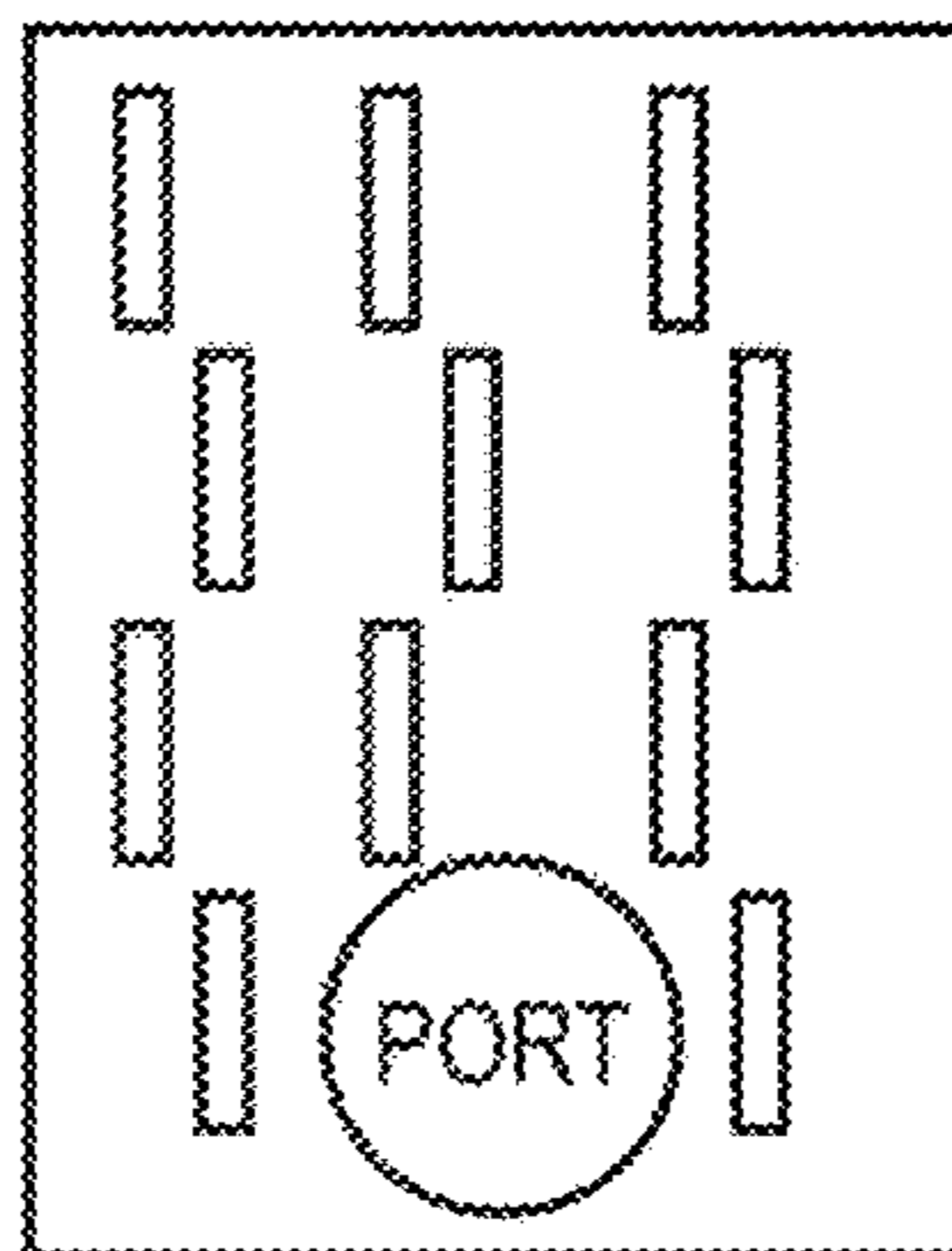


FIG. 28E

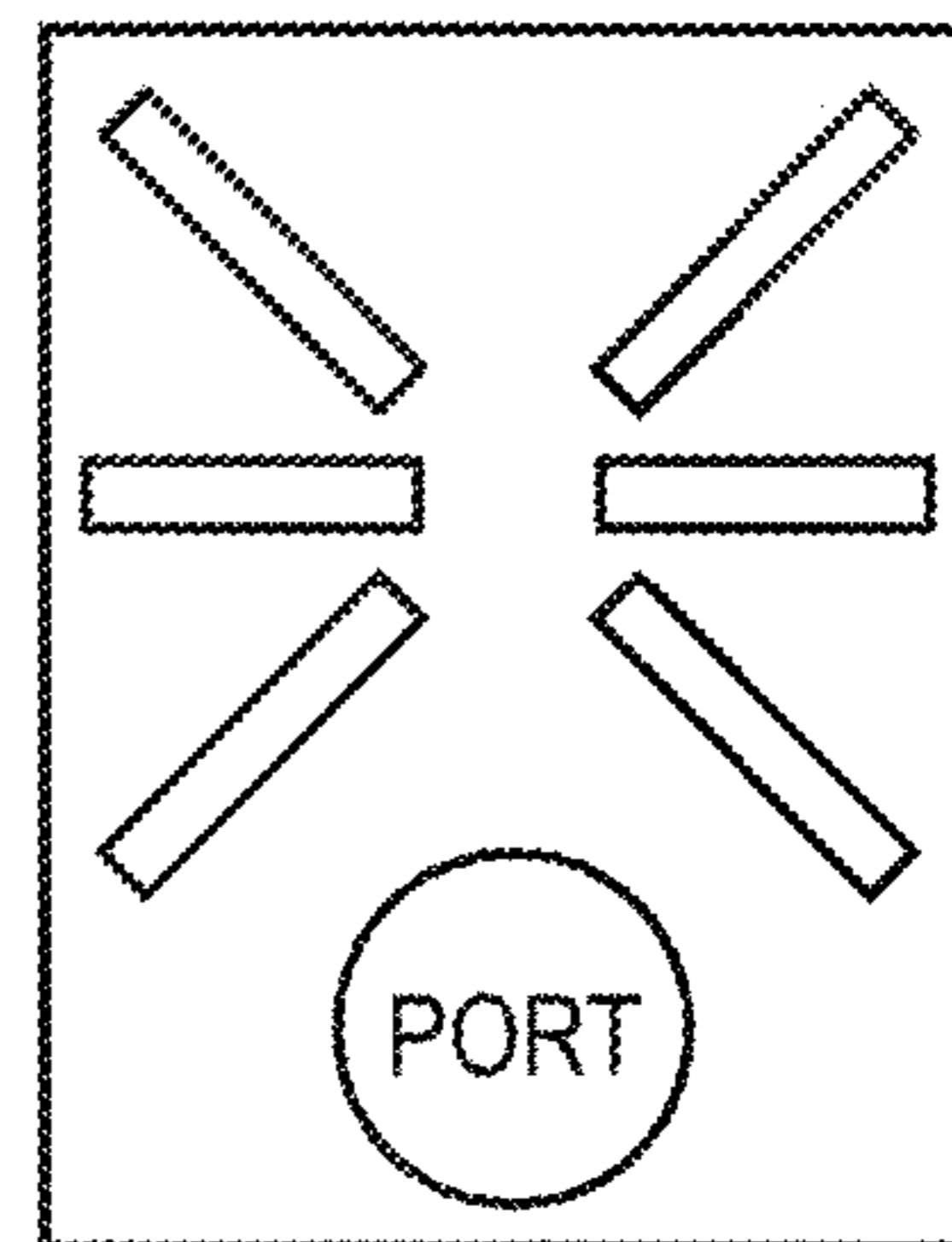


FIG. 28F

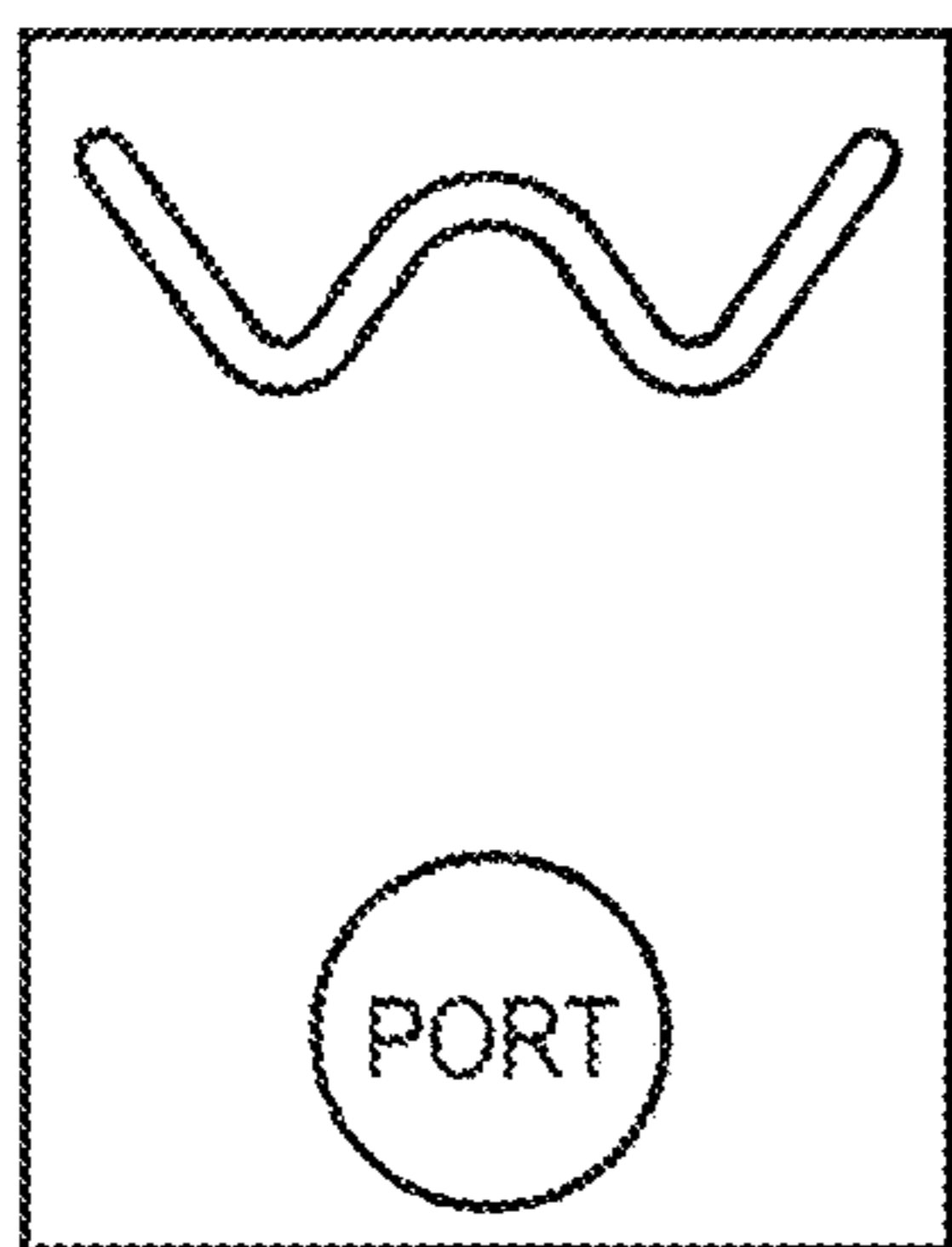


FIG. 28G

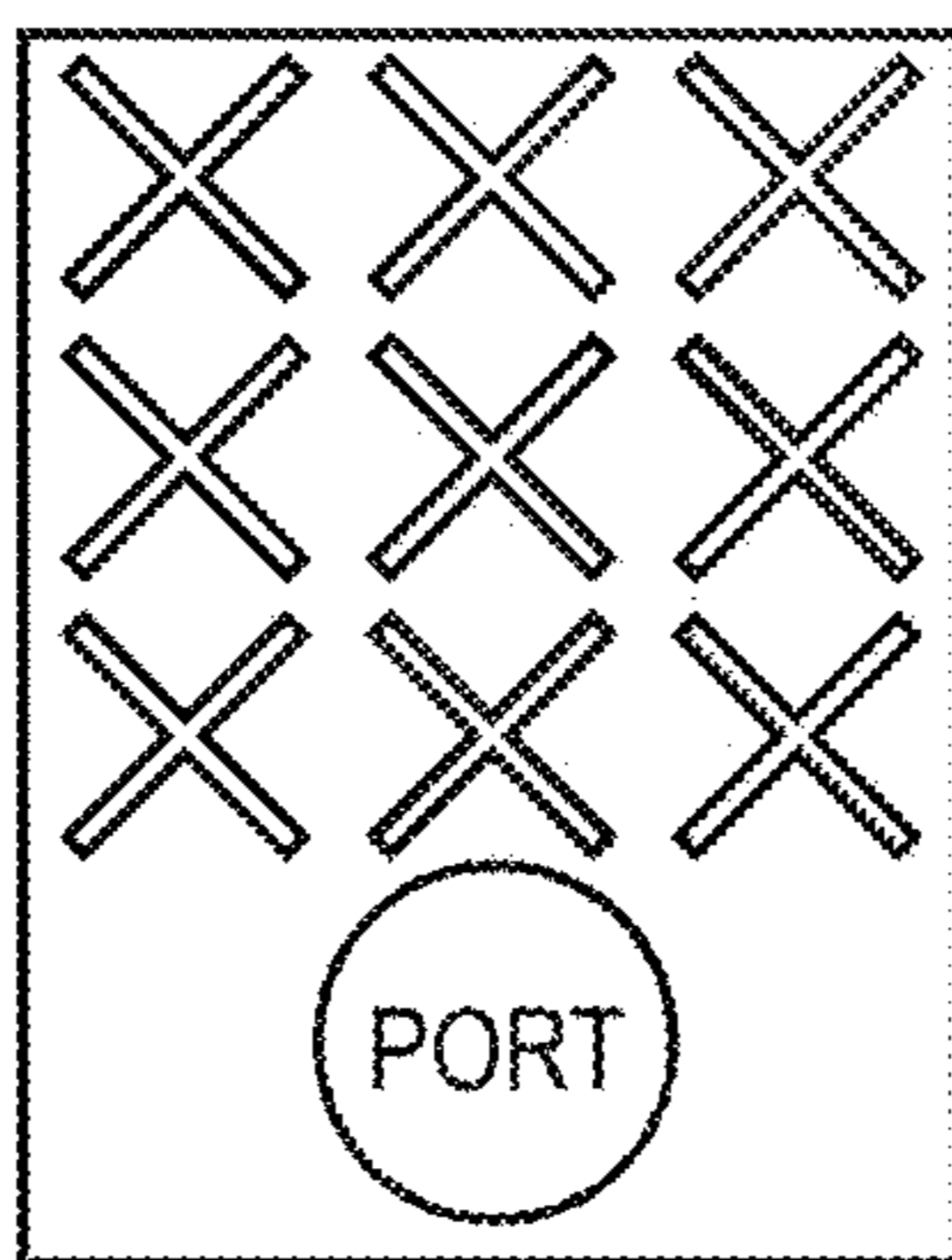


FIG. 28H

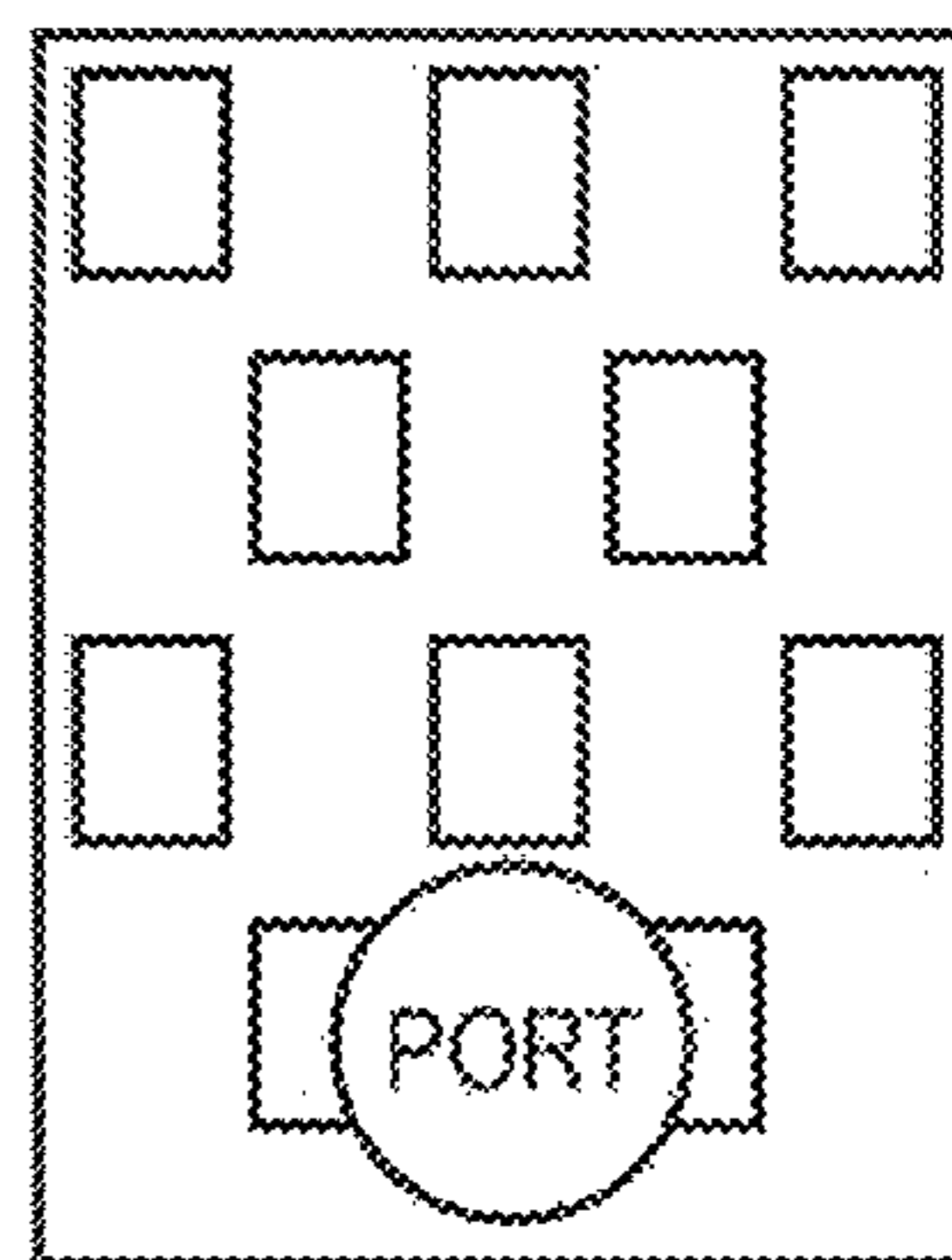


FIG. 28I

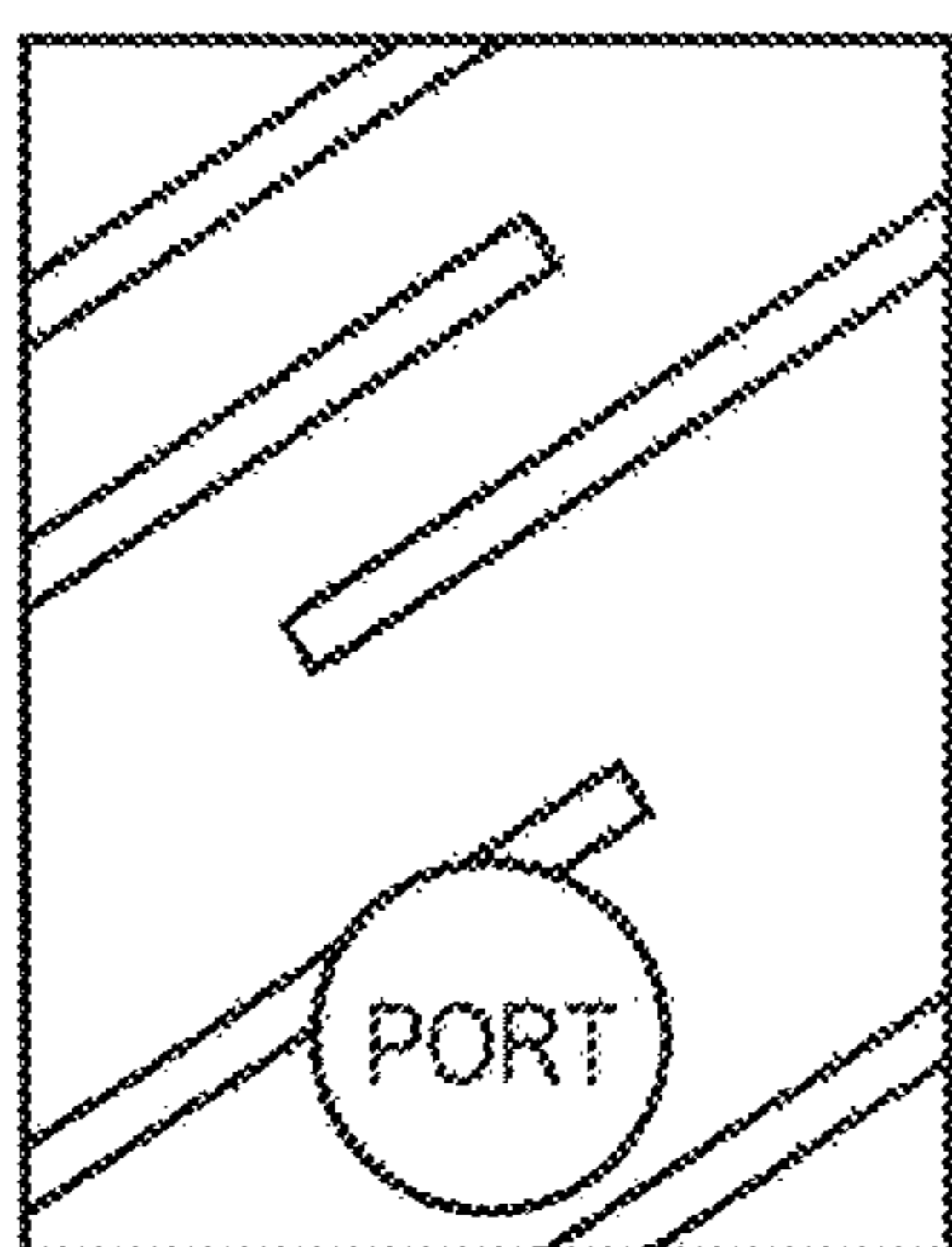


FIG. 28J

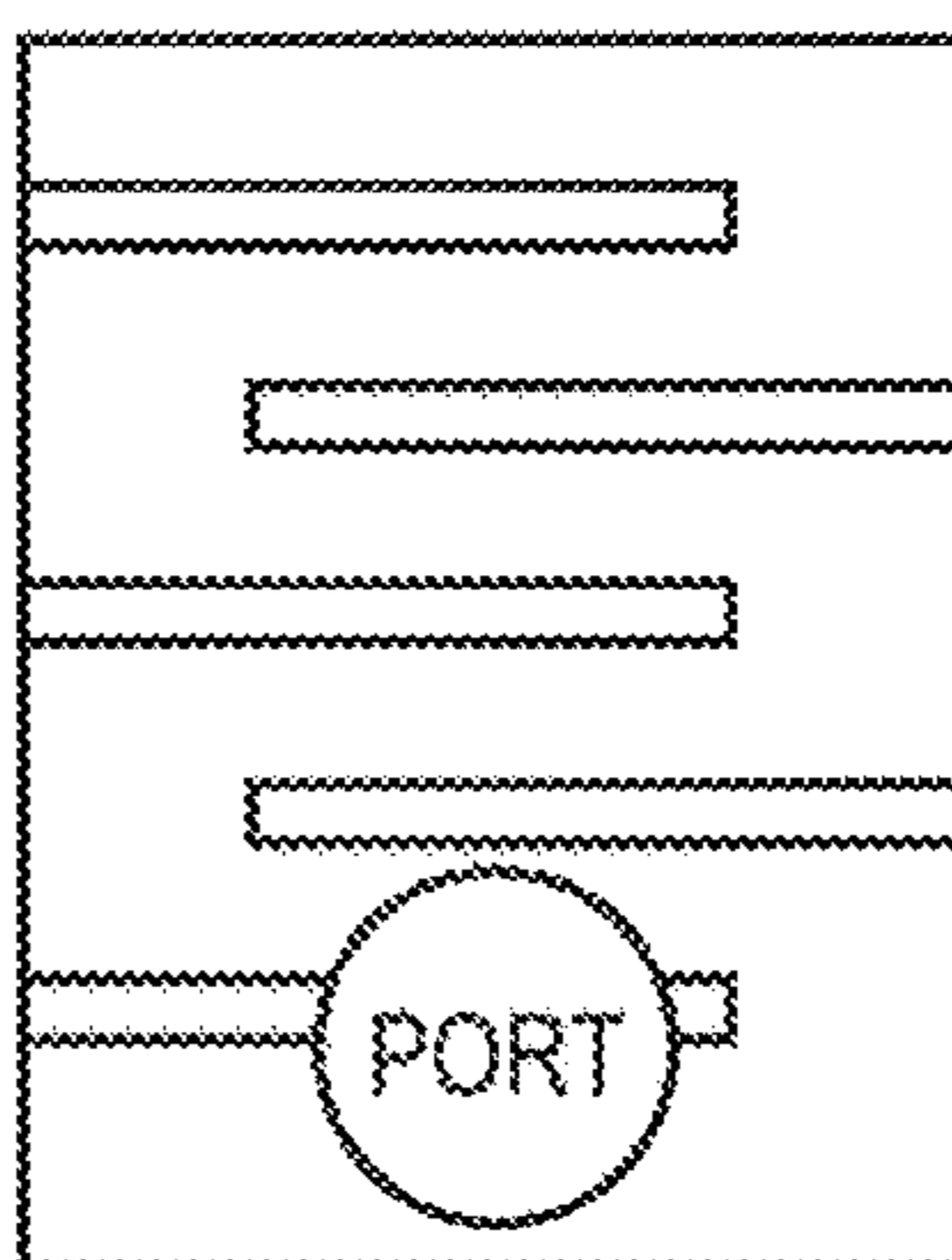


FIG. 28K

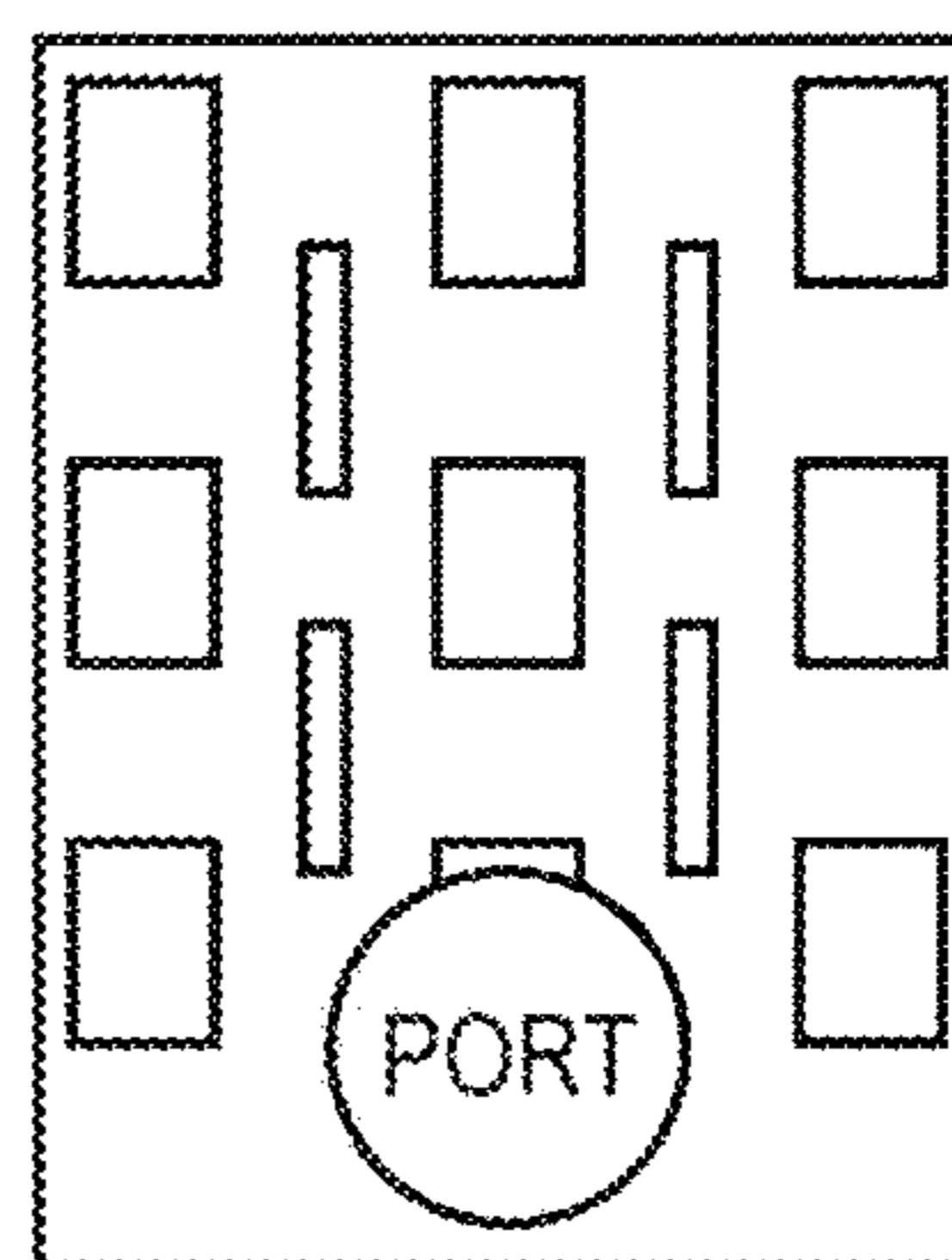


FIG. 28L

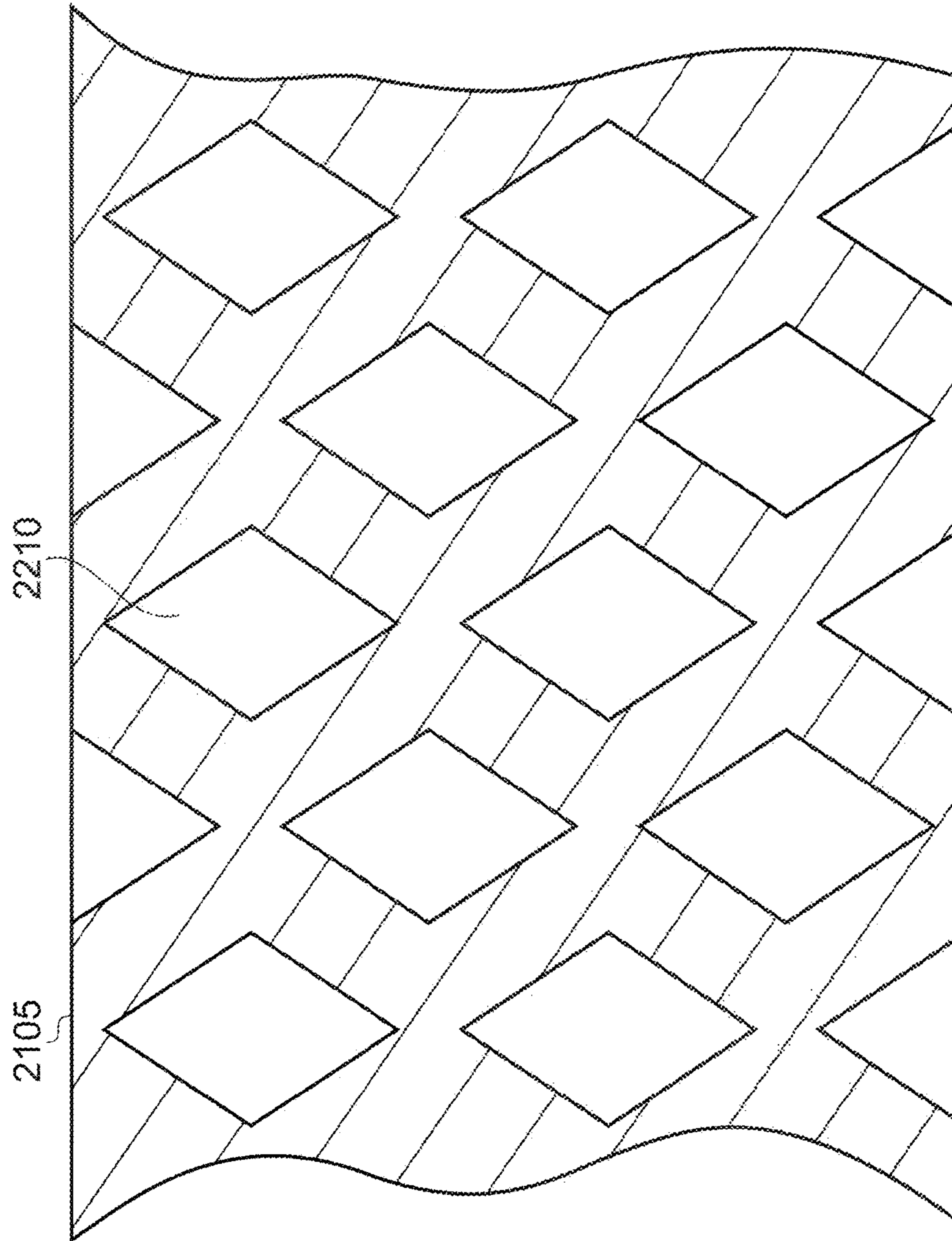


FIG. 29

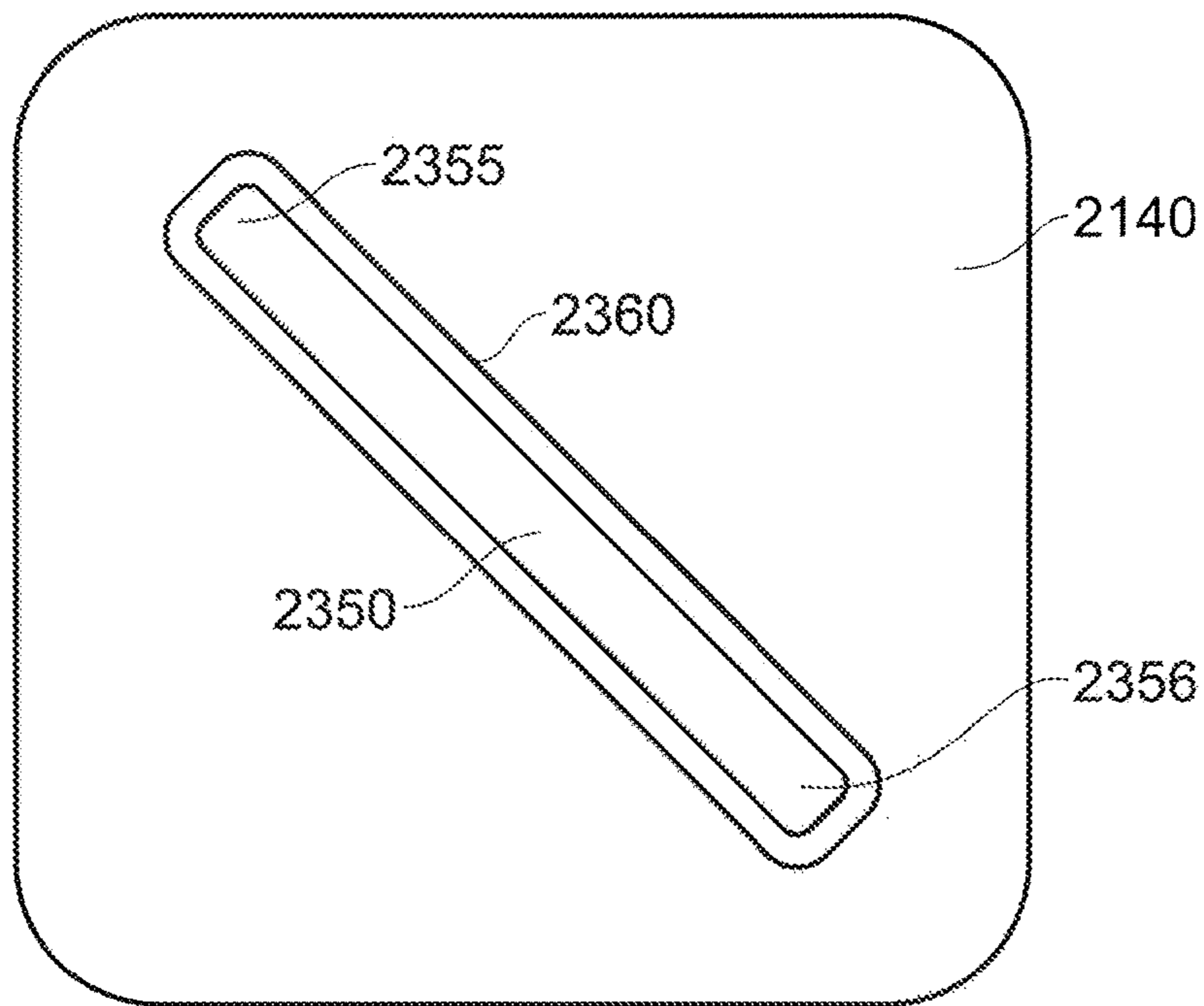


FIG. 30

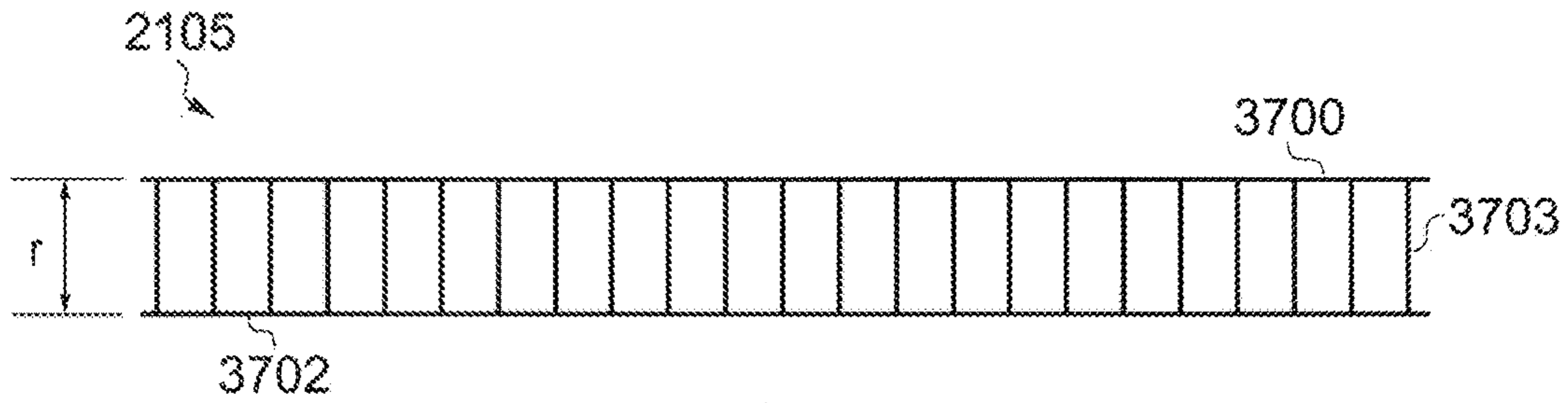


FIG. 31

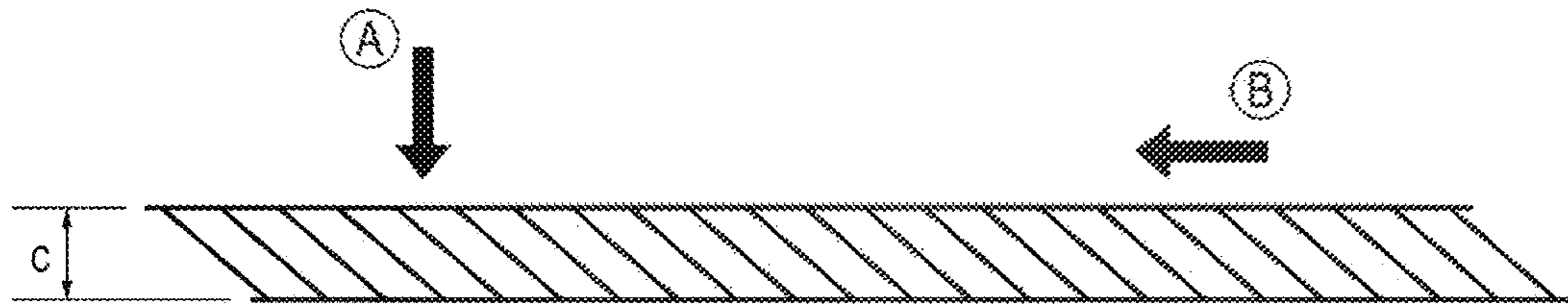


FIG. 32

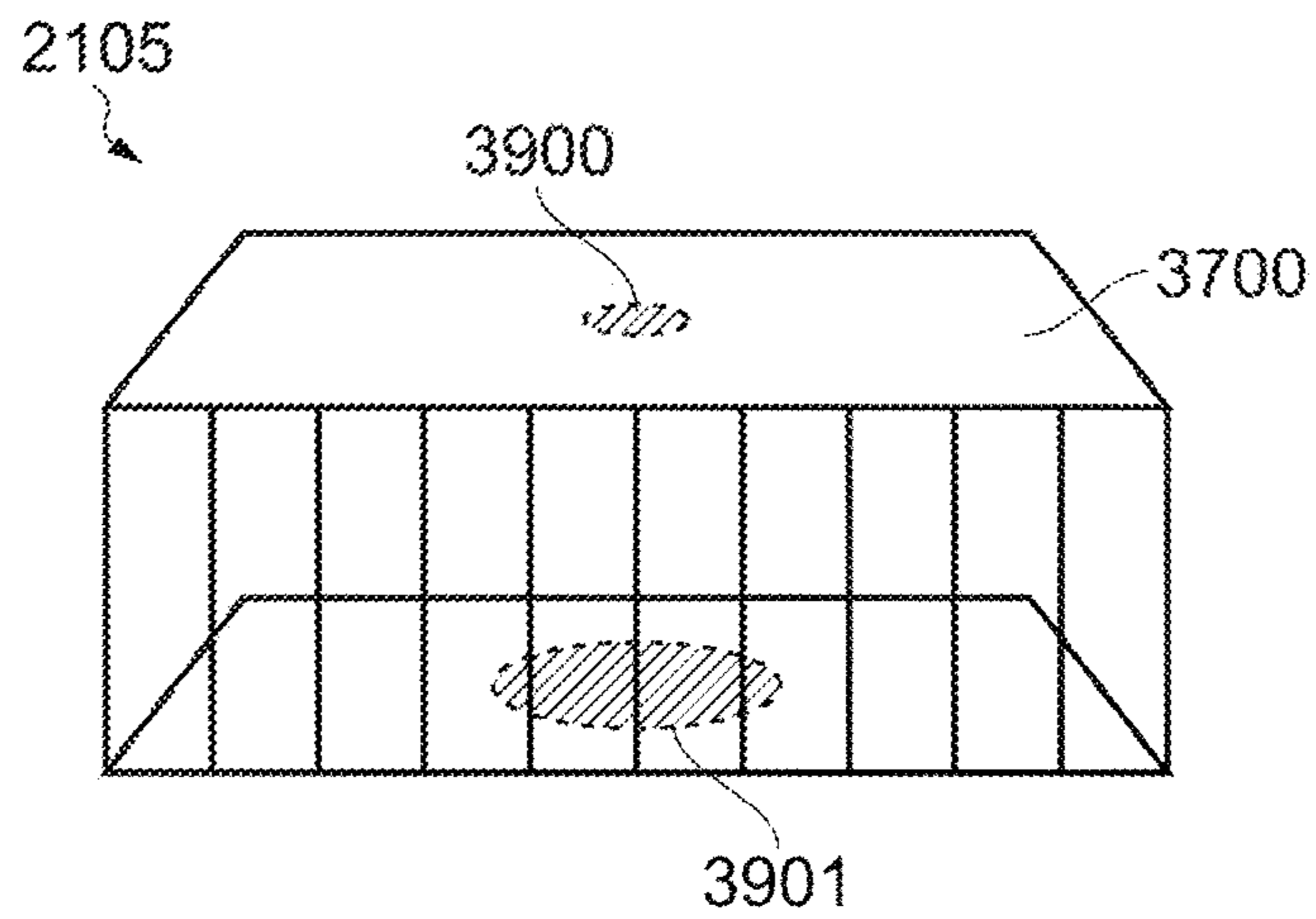


FIG. 33

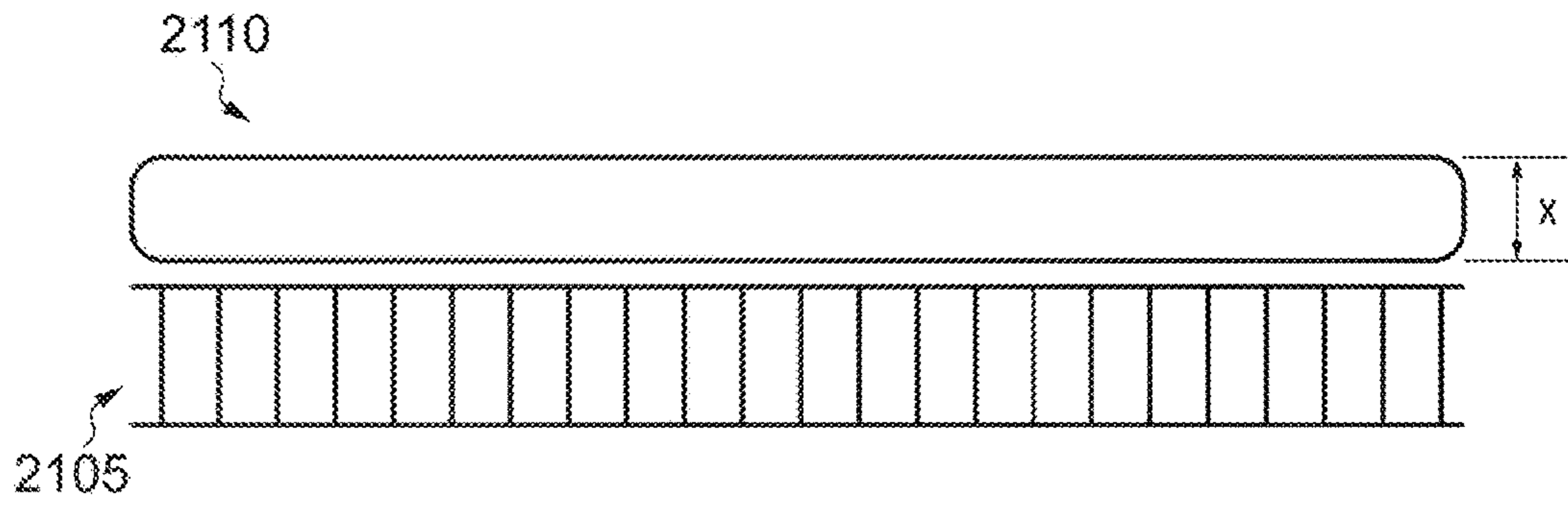


FIG. 34

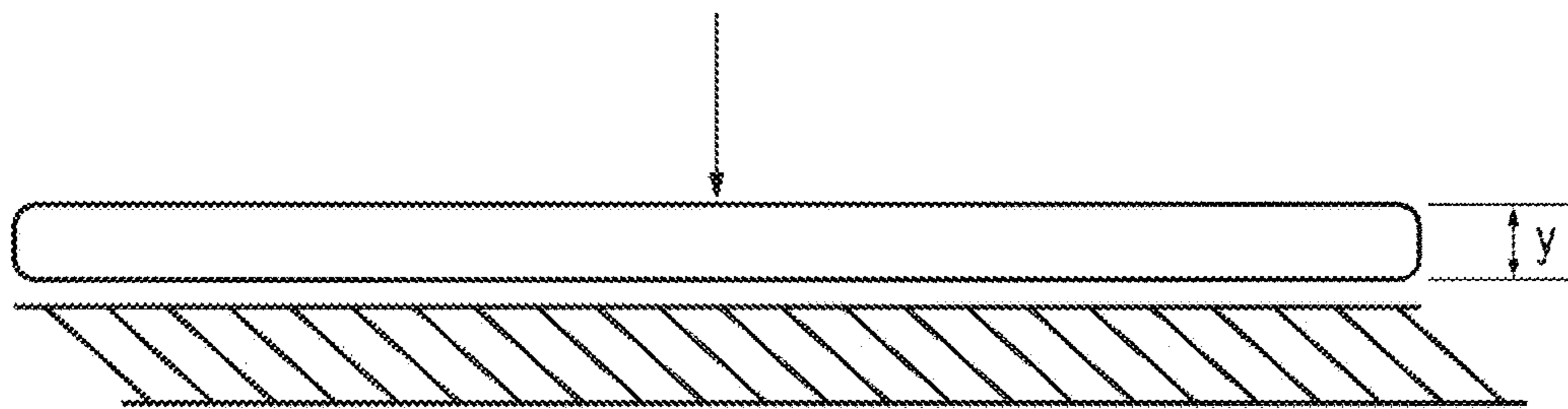


FIG. 35

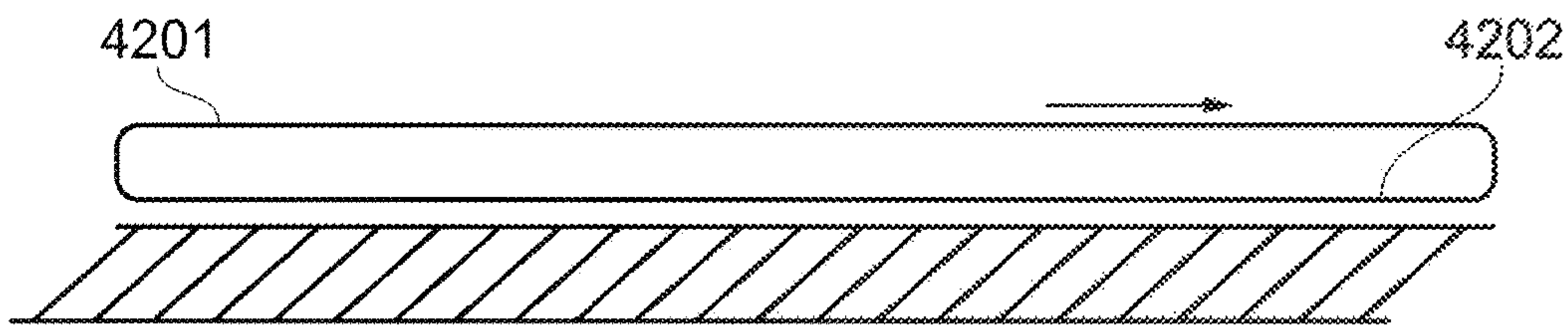


FIG. 36

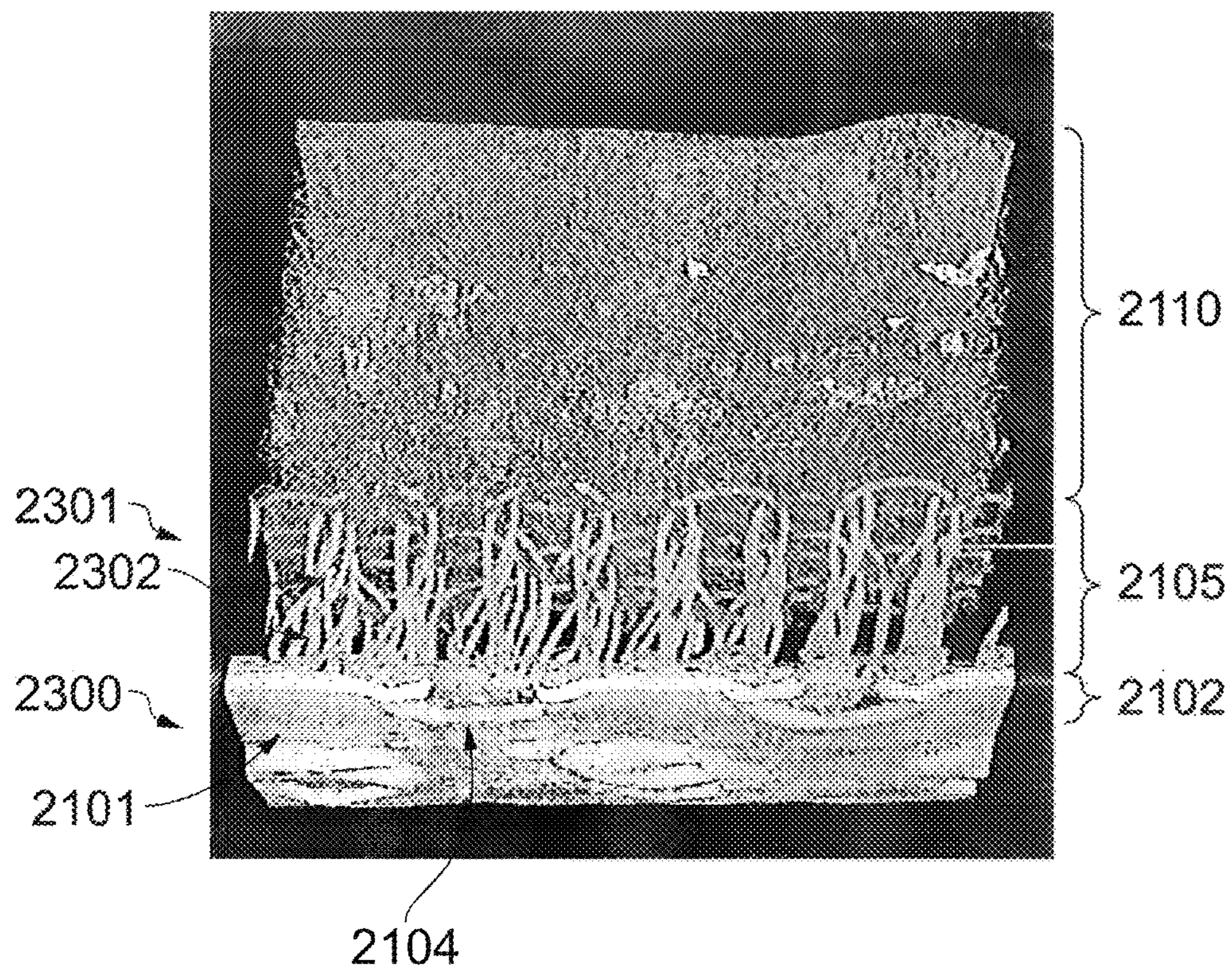


FIG. 37

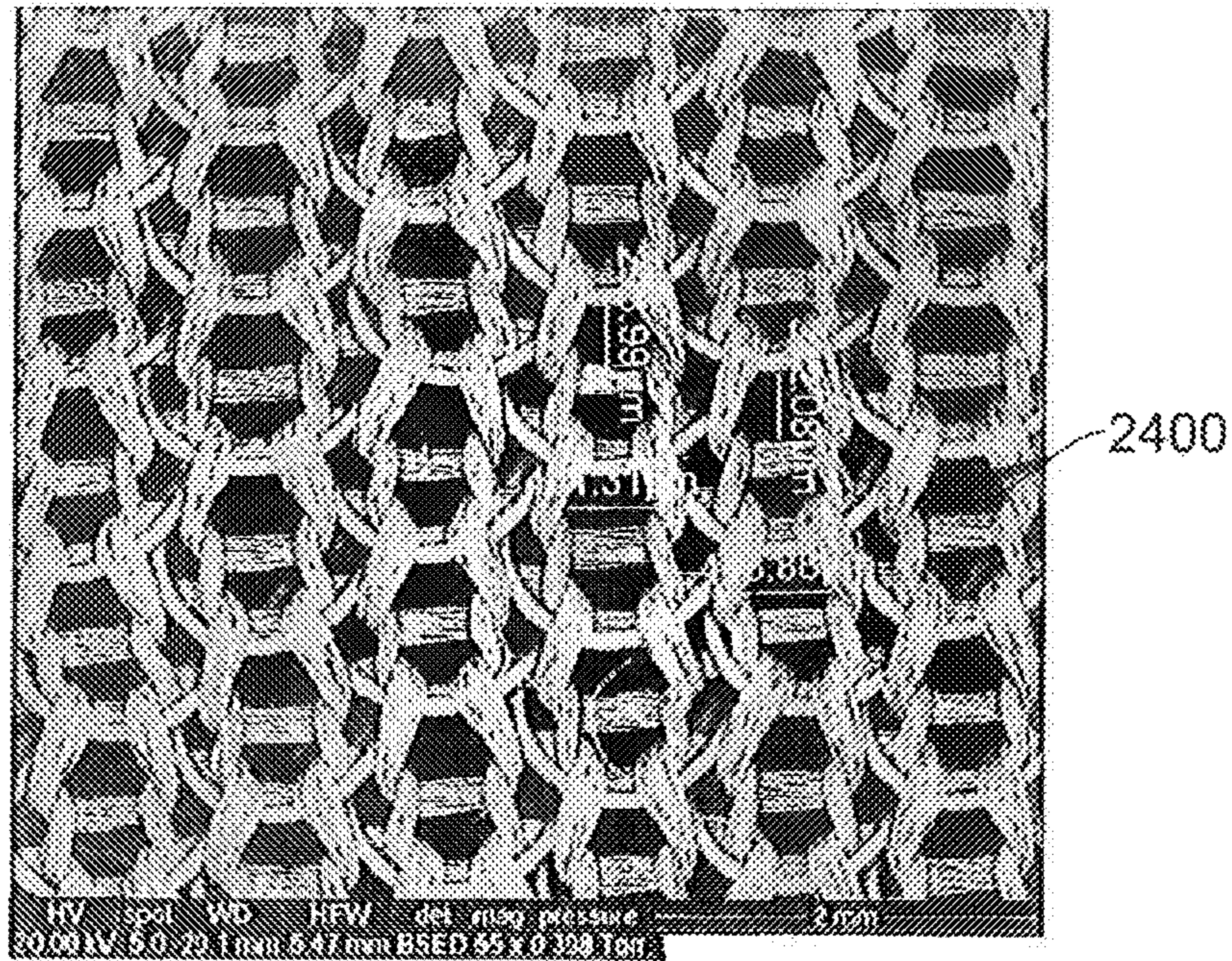


FIG. 38

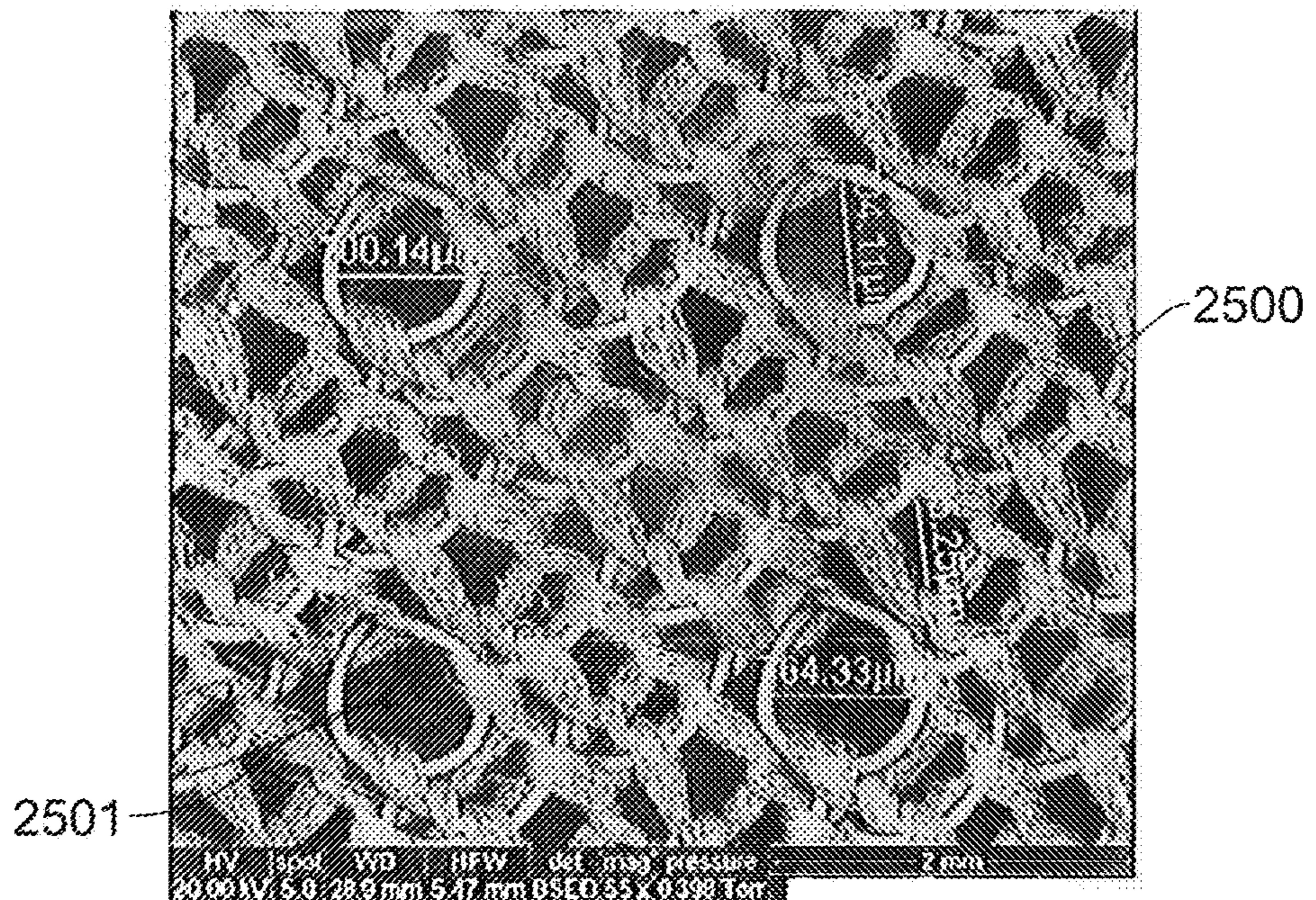


FIG. 39

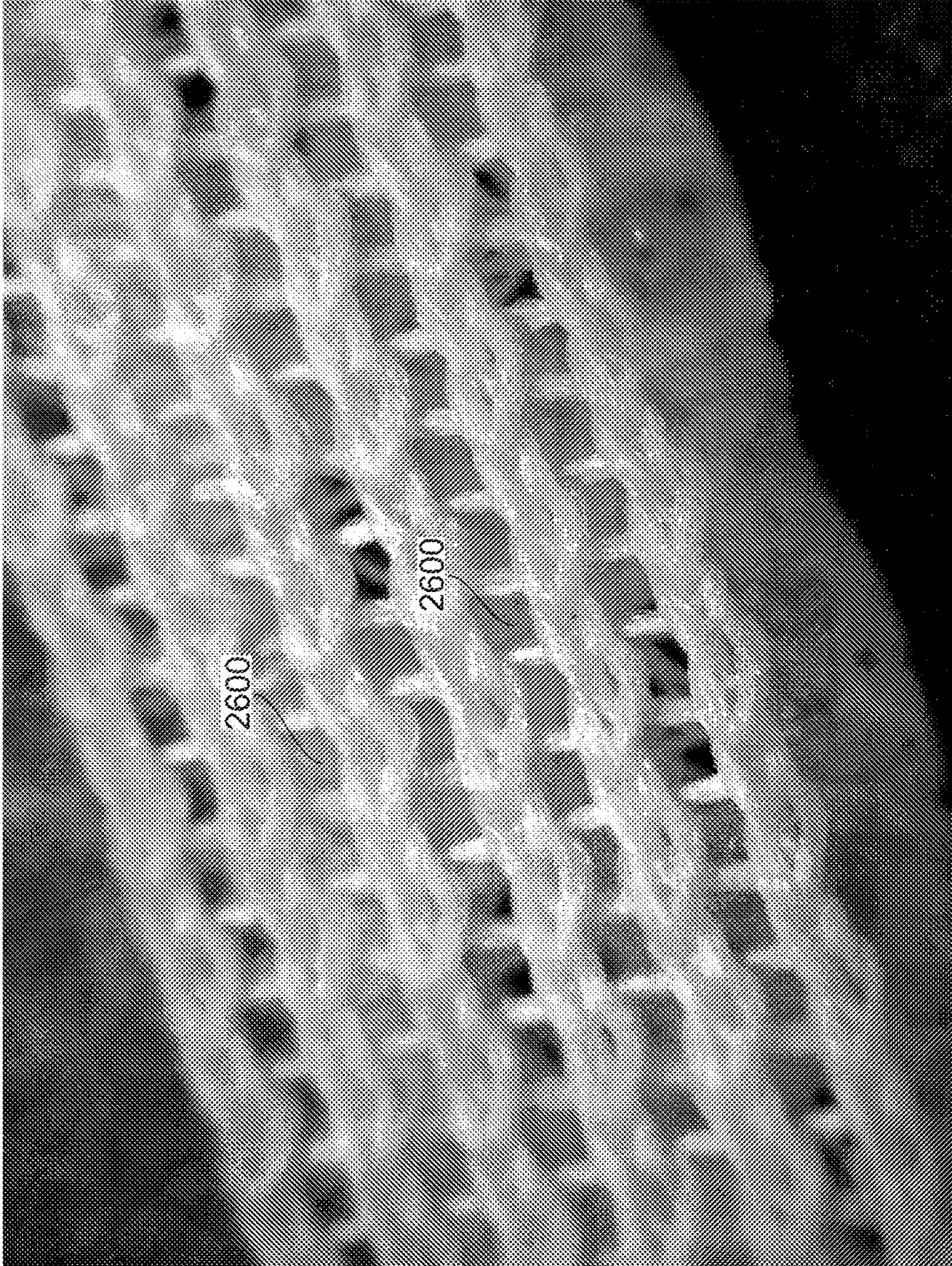


FIG. 40

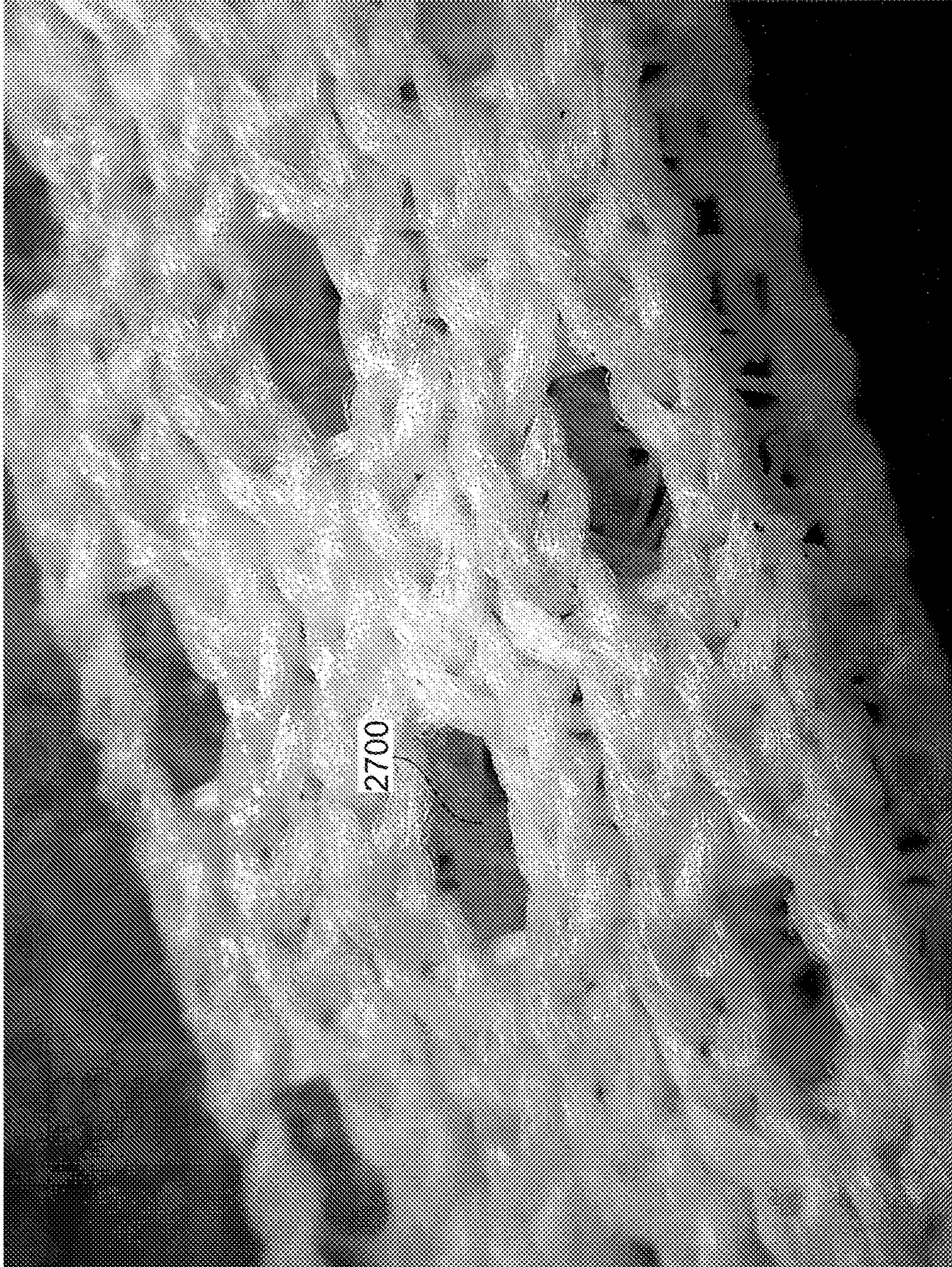


FIG. 41

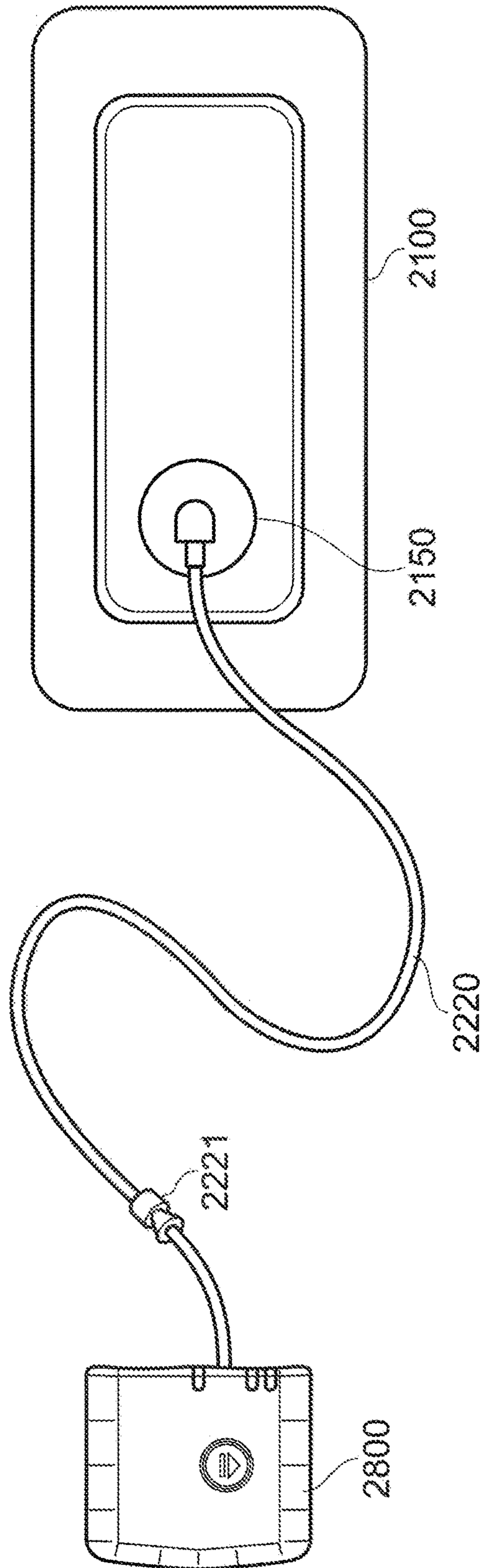


FIG. 42

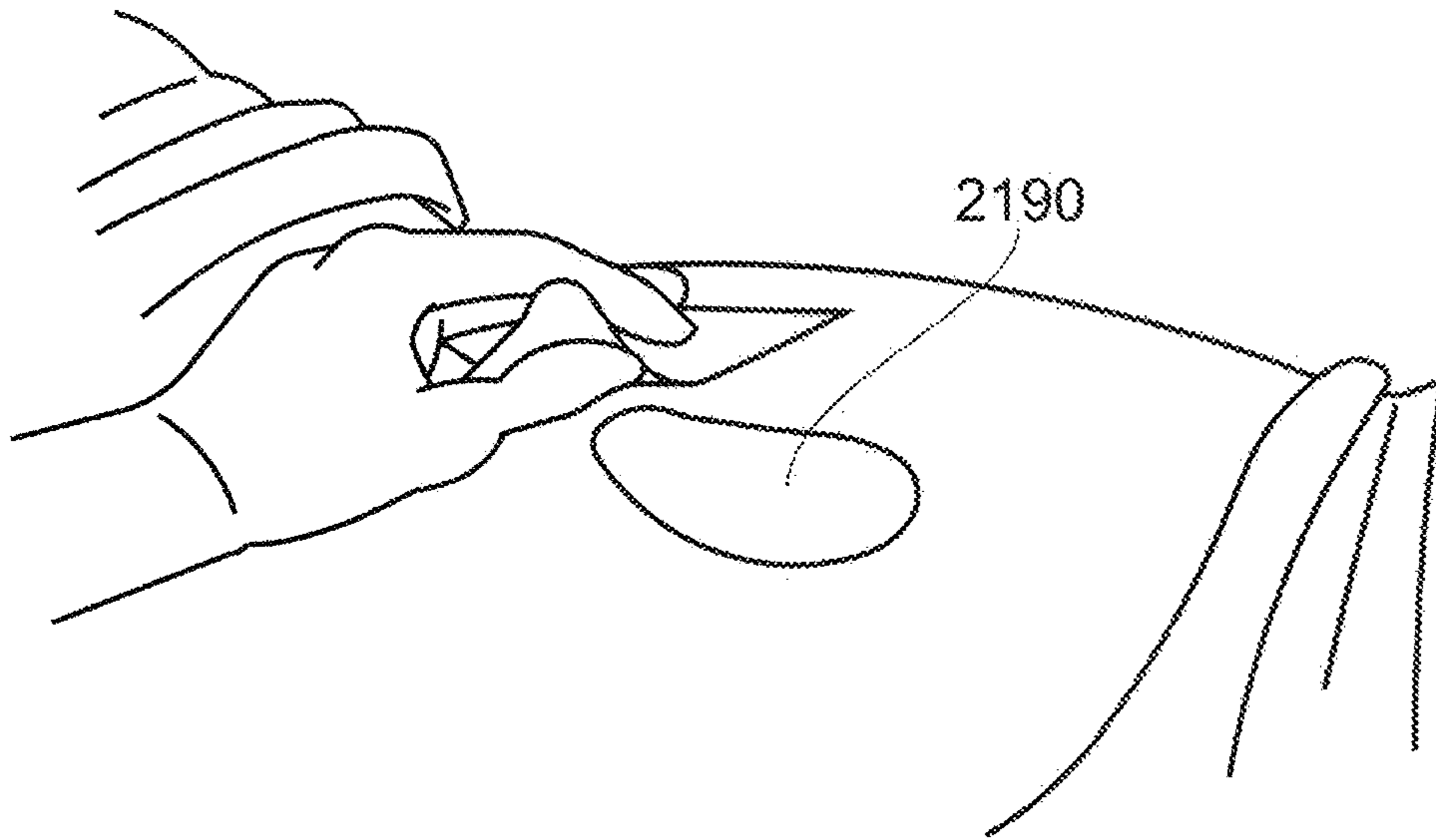


FIG. 43A

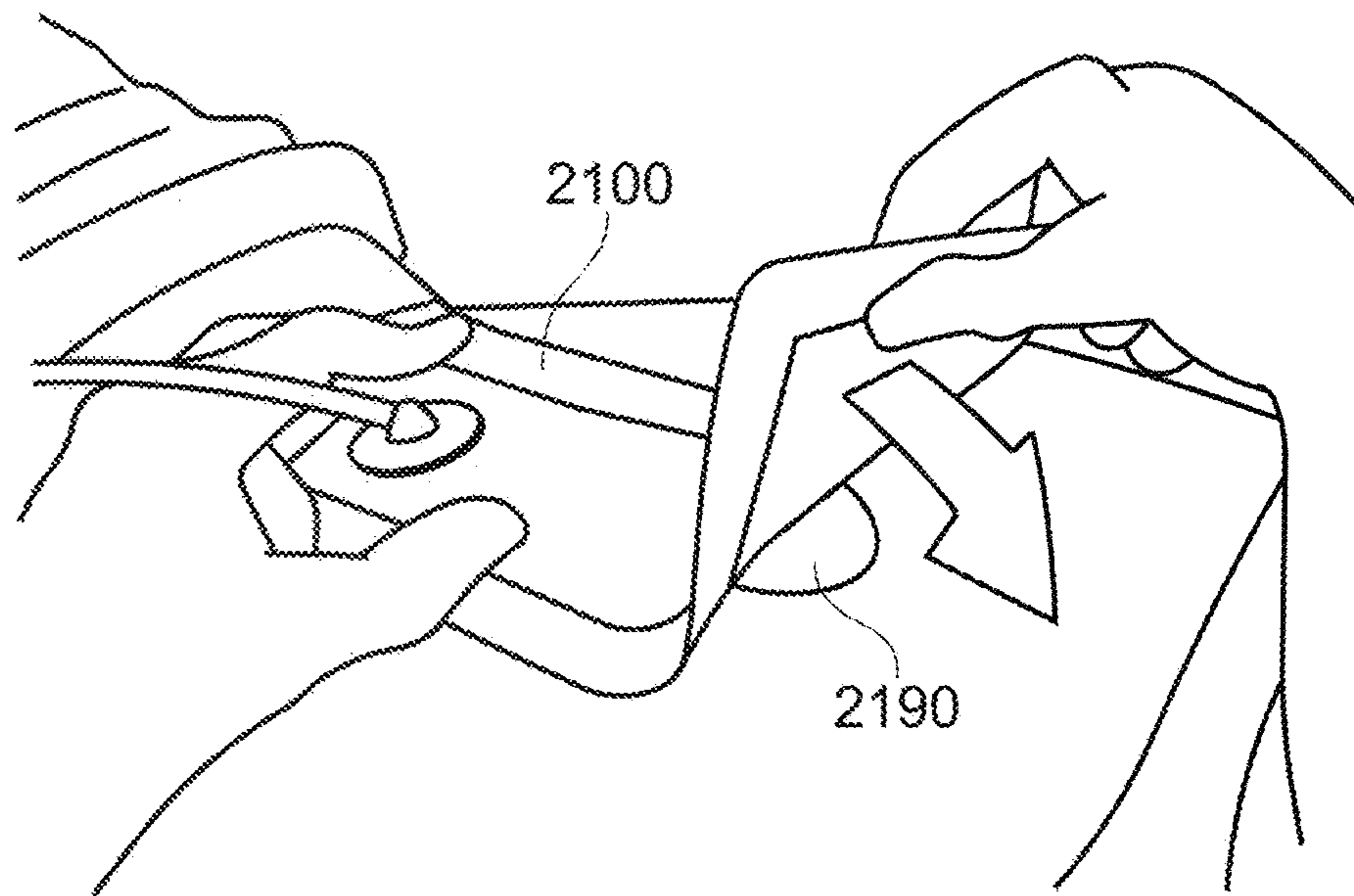


FIG. 43B

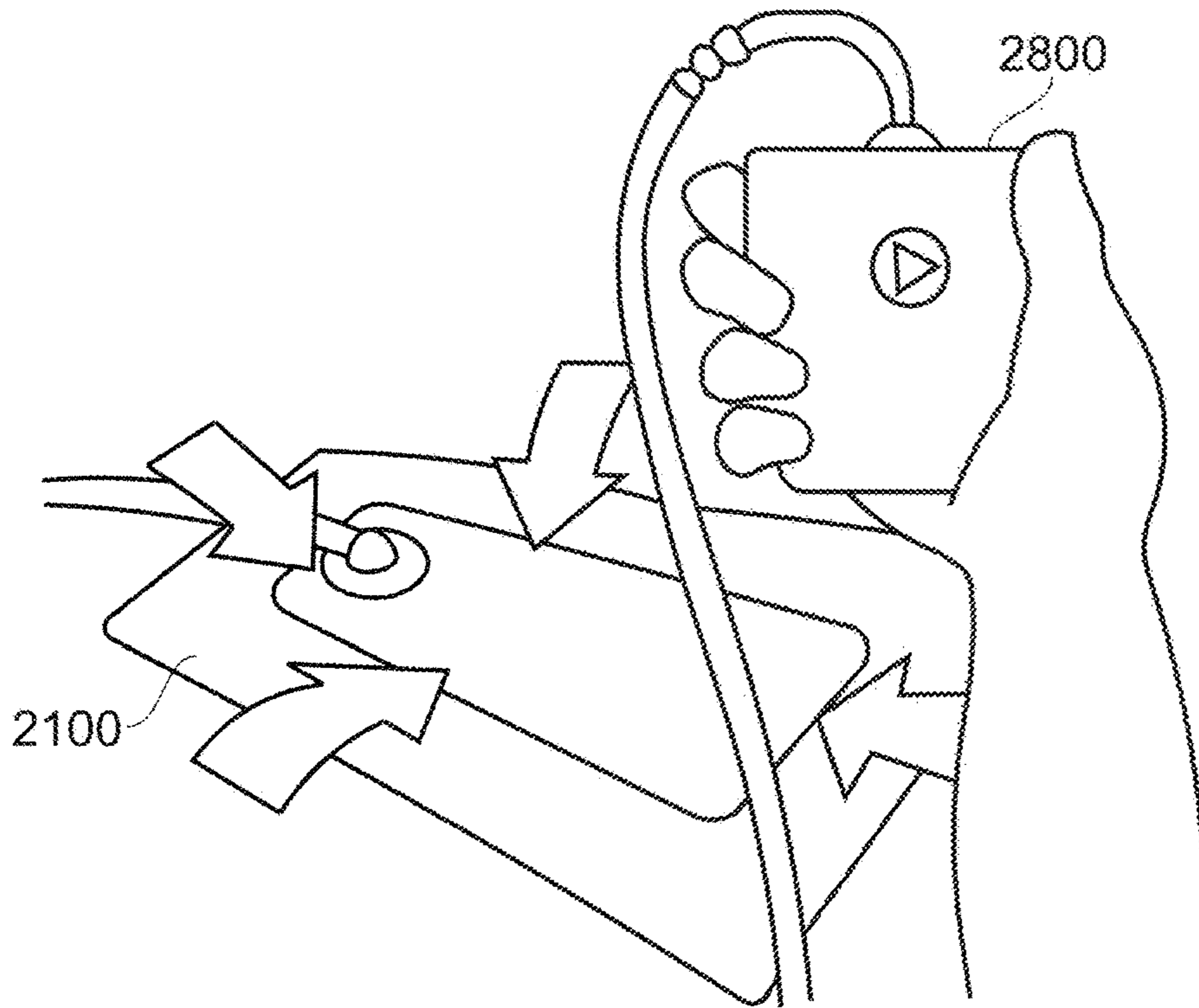


FIG. 43C

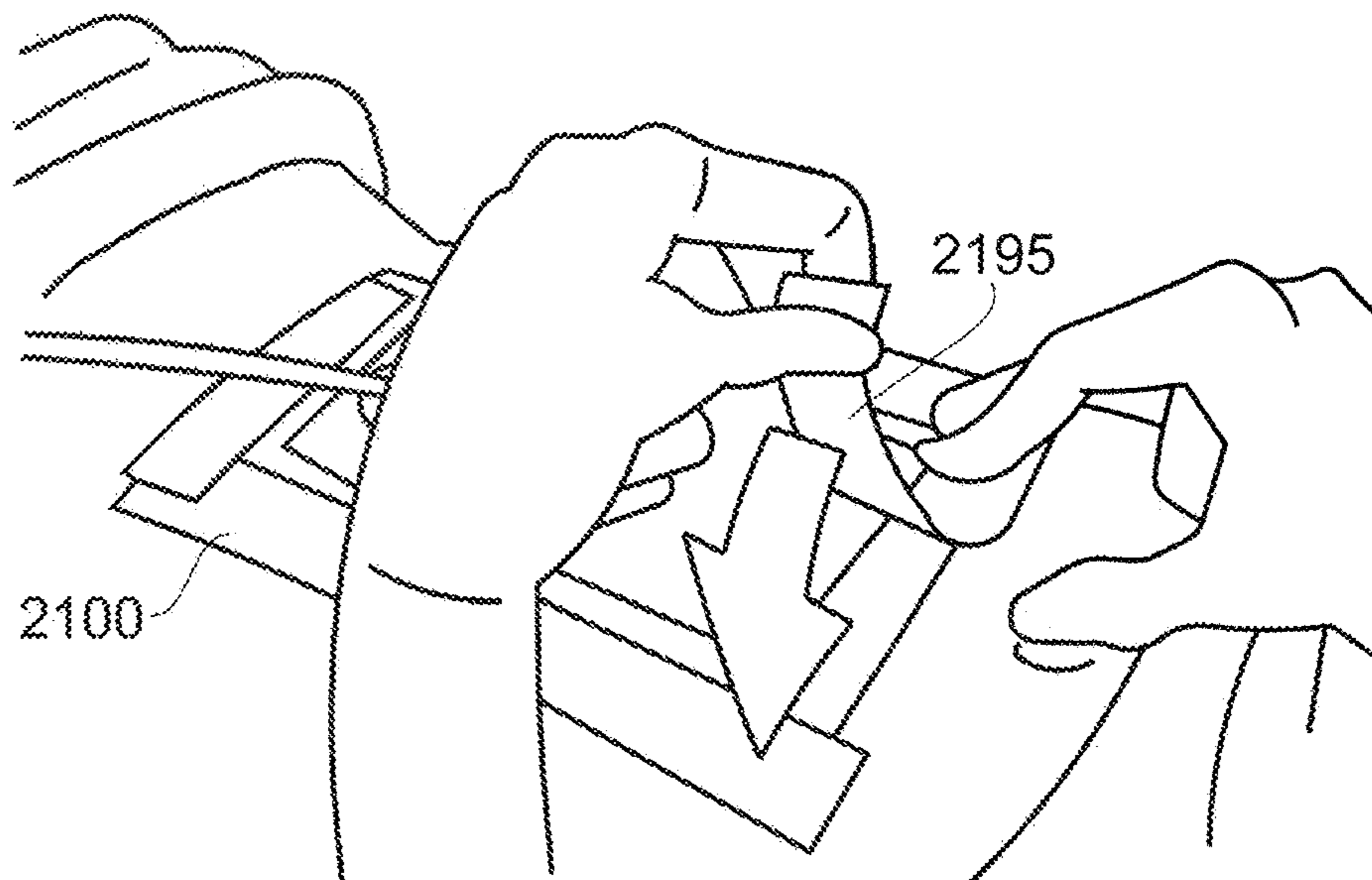


FIG. 43D

**WOUND DRESSING AND METHOD OF
TREATMENT**

Matter enclosed in heavy brackets [] appears in the original patent but forms no part of this reissue specification; matter printed in italics indicates the additions made by reissue; a claim printed with strikethrough indicates that the claim was canceled, disclaimed, or held invalid by a prior post-patent action or proceeding.

CROSS-REFERENCE TO RELATED
APPLICATIONS

This application is a reissue of U.S. Pat. No. 10,039,673, which issued Aug. 7, 2018, from U.S. patent application Ser. No. 15/220,204, filed Jul. 26, 2016, incorporated herein by reference, which is divisional of U.S. application Ser. No. 14/232,607, having a 371(c) date of May 21, 2014, now U.S. Pat. No. 9,877,872, which is a U.S. National Phase of the PCT International Application No. PCT/GB2012/000587, filed on Jul. 12, 2012, which claims priority to UK Application Nos. 1112084.7 and 1211171.2, filed on Jul. 14, 2011 and Jun. 22, 2012, respectively.

Some embodiments of the present disclosure relate to a wound dressing and a method of treatment. In particular, but not exclusively, the present disclosure relates to an apparatus and method for providing protection at a wound site, for absorbing wound exudate, and providing a number of benefits to both users and those around them over known techniques.

Patients have to live with chronic or acute wounds for durations ranging from a number of days to a number of years. Their quality of life is unavoidably affected, and even more so if the impact of the wound on patients' daily activities cannot be minimised by the dressing chosen.

Patients often report fear of the dressing leaking, of odour from the wound incommoding their relatives, or of the dressing becoming unsightly as it is being used. As patients move, the dressing may be submitted to stretching and/or bending of the skin, or rubbing from clothes or bed linen. While modern dressings are designed to stretch to some extent, lifting of the dressing borders during everyday activities does occur, and reinforces concerns about leakage and odour. The corresponding worry about stigma, and cleanliness, can limit a patient's activities in a way that is not beneficial to their overall healing.

In addition, when patients are mobile, fear of damaging their wound further through painful knocks is also present.

The every-day life of patients with a wound can be seen as a balance of risks and benefits. The decisions taken by patients can sometimes go against the prescribed treatment or behaviour recommended by clinicians. Addressing some of the patients' concerns about the state of their dressing while they are wearing it could help to steer patient decisions towards concurring with the clinician's recommendations.

In summary, the above-mentioned problems have heretofore been approached in the following ways:

Prevention of leaks: wound dressing have resorted to the use of superabsorbers in their construction to try to limit leakage of wound exudates out of the dressing pad. EP1156838 describes a wound dressing which combines a foam layer and an absorbent layer in intimate contact with the foam, and capable of draining the foam. EP0758219 describes a method for producing such an article.

Odour: several odour control dressings exist, including either activated charcoal layers (Carboflex®, Askina Car-

bosorb®, Sorbsan Plus Carbon®, Carbonet®, Lyofoam C®) or cyclodextrins embedded into a hydrocolloid (ExuDerm Odorshield®, Avery Dennison). Where activated charcoal is used, it is most often placed behind a barrier layer, the intent of which is to keep the charcoal as dry as possible to enable it to trap odours. U.S. Pat. No. 6,348,423 describes an odour-control absorbent dressing, which contains a barrier layer between the wound side of the pad and its odour layer. GB2420286 describes the use of activated charcoal to control wound odour. WO0209782 describes the use of cyclodextrins incorporated into a non-adhering wound dressing. No adhering absorbent dressing also containing a means of controlling odour is currently available on the market.

Conformability and movement: some dressings have been designed to be more conformable to the body than a standard square shape. This is the case for example of dressings design especially for the heel area, or for the sacrum area. WO2008/149107 describes a sacrum dressing with preferential folding lines. In such dressings, both the border and the pad of the dressing can be shaped in relationship to the particular area of the body targeted. WO2004/047695 describes a dressing with indentation in its pad in a honeycomb pattern. Further related patent applications describe other beneficial formats of indentations. An existing product, Comfeel Plus® by Coloplast, has a shaped border which is claimed to increase adhesion and conformability. Furthermore, EP0902672 describes a conformable dressing which has a permanent set after application.

Appearance and cleanliness do not seem to be addressed by existing product offerings, or to have been considered an issue for the patient in the published literature.

Protection from shocks and pressure relief: This problem seems to have been tackled in the industry in the light of preventing pressure ulcers from developing or worsening. It is generally accepted that structures containing air bubbles or gel parts will be able to absorb some of the energy put into compressing a dressing, until the force applied leads to the collapse of the dressing thickness. Foam dressings have therefore been used as part of a pressure relief protocol in clinical settings, but in conjunction with other methods.

WO2007/075379 describes a bi-component dressing, where a first part is formed as a wall around the circumference of the wound, and a second, flatter part, is placed on top of the wall. Pressure applied over a wider area than that delimited by the wall, such as under a compression bandage, would be mostly taken up by the shield structure.

WO2006/091735 and US2009/0069737 describe a similar concept, where a layer of material is punctured. EP1164995 builds on this idea, where a pressure-relieving structure surrounds an absorbent part of the dressing, and is in contact with the skin.

WO2011/144888 describes the use of a three-dimensional knit within a dressing.

The inventors have not found a structure described that meets more than one of the patient needs outlined above. However, patient satisfaction with a particular treatment, and therefore the likelihood that they will comply with it, depends on several clinical and social factors.

According to a first aspect of the present disclosure, there is provided a wound dressing for providing protection at a wound site, comprising:

- an absorbent layer for absorbing wound exudate; and
- an obscuring element for at least partially obscuring a view of wound exudate absorbed by the absorbent layer in use.

3

According to a second aspect of the present disclosure, there is provided a method of manufacturing a wound dressing, comprising:

providing an absorbent layer for absorbing wound exudate; and

providing an obscuring element for at least partially obscuring a view of wound exudate absorbed by the absorbent layer in use.

According to a third aspect of the present disclosure, there is provided a wound dressing for providing protection at a wound site, comprising:

an absorbent layer for absorbing wound exudate; and

a shielding layer provided over the absorbent layer, and further from a wound-facing side of the wound dressing than the absorbent layer.

According to a fourth aspect of the present disclosure, there is provided a method of manufacturing a wound dressing, comprising:

providing an absorbent layer for absorbing wound exudate; and

providing a shielding layer over the absorbent layer, and further from a wound-facing side of the wound dressing than the absorbent layer.

According to a fifth aspect of the present disclosure, there is provided a wound dressing for providing protection at a wound site, comprising:

a shielding layer for spreading pressure applied to the wound dressing over an area larger than the area where the pressure is applied; and

a cover layer provided adjacent to and over the shielding layer, on a non-wound facing side of the wound dressing.

According to a sixth aspect of the present disclosure, there is provided a method of manufacturing a wound dressing, comprising

providing a shielding layer for spreading pressure applied to the wound dressing over an area larger than the area where the pressure is applied; and

providing a cover layer provided adjacent to and over the shielding layer, on a non-wound facing side of the wound dressing.

According to a seventh aspect of the present disclosure, there is provided a wound dressing, comprising:

an absorbent layer for absorbing wound exudate;

a fluid transmission layer; and

an odour controlling element between or in the fluid transmission layer and the absorbent layer.

According to an eighth aspect of the present disclosure, there is provided a method of manufacturing a wound dressing, comprising

providing an absorbent layer for absorbing wound exudate;

providing a fluid transmission layer; and

providing an odour controlling element between or in the fluid transmission layer and the absorbent layer.

According to a ninth aspect of the present disclosure, there is provided a wound dressing, comprising: an odour control material and at least one of a foam, an absorbent layer and a shielding layer, wherein the odour control material is incorporated into the at least one other material.

According to a tenth aspect of the present disclosure, there is provided a method of manufacturing a wound dressing, comprising providing an odour control material and at least one of a foam, an absorbent layer and a shielding layer, wherein the odour control material is incorporated into the at least one other material.

4

According to an eleventh aspect of the present disclosure, there is provided a wound dressing, comprising:

an absorbent layer for absorbing wound exudate,

wherein the dressing is shaped to include sub-areas, wherein the dressing has rotational symmetry, and the sub areas define areas of the dressing that are formable in different directions with respect to each other.

According to a twelfth aspect of the present disclosure, there is provided a method of manufacturing a wound dressing comprising

providing an absorbent layer for absorbing wound exudate,

and shaping the dressing to include sub-areas, wherein the dressing has rotational symmetry, and the sub areas define areas of the dressing that are formable in different directions with respect to each other.

Certain embodiments of the present disclosure provide the advantage that a wound dressing is provided that has a reduced aesthetic impact for users (compared to known dressings) yet allows clinicians to examine and visually assess the wound area, such as assessing presence of blood, infection by-products and/or the extent of exudate spread across the dressing.

Certain embodiments of the present disclosure provide the advantage that a wound dressing is provided that has improved conformability to an area of a patient to which it is attached, particularly for areas that are not flat/planar.

Certain embodiments of the present disclosure provide the advantage that a wound dressing is provided that has improved performance in terms of protecting a user from shocks or pressure.

Certain embodiments of the present disclosure provide the advantage that odour from a wound is controlled.

Some embodiments provide the advantage that the wound dressing can be used to collect wound exudate generated during a negative pressure therapy process. A pump remote from the wound dressing or supported thereby can be connected to the wound dressing and reused (or can be disposable) whilst the wound dressing itself is used to collect wound exudate and may then be disposed of after use. The pump or other source of negative pressure can be connected to the wound dressing through a flexible tubing or conduit. In this arrangement, negative pressure can draw wound exudate and other fluids or secretions away from the wound site.

Any of the embodiments disclosed herein are suitable for use with and, hence, can be used with a negative pressure wound therapy system to aid in wound closure and healing in which wound exudate drawn from a wound site during the therapy is collected and stored in a wound dressing and/or in a collection canister.

It is the aim of some wound dressing embodiments disclosed herein to have an increased capacity for absorbing wound exudate reducing the frequency with which the dressings must be changed. It is further an aim of certain wound dressing embodiments disclosed herein to manage the movement of wound exudate through a dressing to avoid blockages occurring that lead to reduced life of the dressing.

It is an aim of some wound dressing embodiments of the present disclosure to provide a wound dressing having an increased capacity to absorb compressive forces exerted on the wound dressing.

It is an aim of some wound dressing embodiments disclosed herein to provide a wound dressing having an increased capacity to prevent shear forces from an outer surface of a wound dressing from being translated into corresponding shear forces at a wound site.

5

It is an aim of some wound dressing embodiments disclosed herein to provide a wound dressing which can “give” in a direction perpendicular to and parallel to a wound site surface even when the dressing experiences negative pressure.

It is an aim of some wound dressing embodiments disclosed herein to provide a wound dressing able to be used with topical negative pressure therapy which helps maintain an open flow path so that therapy can be continued unhindered by blockages caused by build-up of solid matter.

It is an aim of some wound dressing embodiments disclosed herein to provide a method and apparatus for treating a wound with topical negative pressure therapy by preventing blockage of a flowpath region of a wound dressing.

Some embodiments disclosed herein are directed toward the treatment of wounds with negative pressure wound therapy. In particular, any of the dressing embodiments disclosed herein can be used for absorbing and storing wound exudate in conjunction with a pump, for example a miniaturized pump. Any of the wound dressing embodiments disclosed herein can further comprise a transmission layer configured to transmit wound exudates to an absorbent layer disposed in the wound dressing. Additionally, any of the wound dressing embodiments disclosed herein can be adapted to provide for a port or other fluidic connector configured to retain wound exudate within the wound dressing while transmitting negative pressure to the wound dressing, though such a feature is not required.

According to an embodiment of the present disclosure there is provided a wound treatment apparatus comprising: a wound dressing comprising:

- any of the dressing embodiments disclosed herein;
- a pump; and
- a suction port for applying negative pressure to the wound dressing for the application of topical negative pressure at a wound site, the suction port comprising:
 - a connector portion for connecting the suction port to the pump;
 - a sealing surface for sealing the suction port to the cover layer of the wound dressing; and
 - a liquid impermeable gas permeable filter element arranged to prevent a liquid from entering the connector portion.

According to another embodiment of the present disclosure there is provided a method for the treatment of a wound comprising:

- providing a wound dressing comprising any of the features or combination of features of any of the dressing embodiments disclosed herein, and/or:
 - a transmission layer comprising a 3D knitted or fabric material;
 - an absorbent layer for absorbing wound exudate, the absorbent layer overlying the transmission layer;
 - a cover layer overlying the absorbent layer and comprising an orifice, wherein the cover layer is moisture vapor permeable;
- positioning the dressing over a wound site to form a sealed cavity over the wound site; and
- applying negative pressure to the wound site to draw fluid through the transmission layer into the absorbent layer.

According to another embodiment of the present disclosure there is provided a wound dressing for providing protection at a wound site, comprising any of the features or combination of features of any of the dressing embodiments disclosed herein, and/or:

6

a transmission layer comprising a first surface and a further surface spaced apart from the first surface by a relax distance in a relaxed mode of operation; and a plurality of spacer elements extending between the first and further surfaces and, in a forced mode of operation, locatable whereby the first and further surfaces are spaced apart by a compression distance less than the relax distance.

According to another embodiment of the present disclosure there is provided a method for providing protection at a wound site, comprising:

locating a wound dressing comprising any of the components or features of any of the wound dressing embodiments disclosed herein, and/or a transmission layer over a wound site; and responsive to a force on the wound dressing, displacing a plurality of spacer elements extending between a first surface and a further surface of the transmission layer whereby;

a distance between the first and further surfaces is reduced as the spacer elements are displaced.

According to another embodiment of the present disclosure there is provided an apparatus for dressing a wound for the application of topical negative pressure at a wound site, comprising a wound dressing comprising any of the components or features of any of the wound dressing embodiments disclosed herein, and/or:

- a liquid and gas permeable transmission layer;
- an absorbent layer for absorbing wound exudate, the absorbent layer overlying the transmission layer;
- a gas impermeable cover layer overlying the absorbent layer and comprising a first orifice, wherein the cover layer is moisture vapor permeable.

According to a further embodiment of the present disclosure there is provided a method of applying TNP at a wound site, comprising:

- applying negative pressure at an orifice of a cover layer of any wound dressing embodiment disclosed herein, a peripheral region around the wound site being sealed with the wound dressing, such that air and wound exudate are drawn towards the orifice;
- collecting wound exudate, drawn from the wound site, through a transmission layer of the wound dressing, in an absorbent layer of the wound dressing; and
- transpiring a water component of the wound exudate collected in the absorbent layer through the cover layer of the wound dressing.

According to an additional embodiment of the present disclosure there is provided apparatus for dressing a wound for the application of topical negative pressure at a wound site, comprising a wound dressing comprising any of the components or features of any wound dressing embodiment disclosed herein, and/or:

- a liquid and gas permeable transmission layer;
- an absorbent layer for absorbing wound exudate;
- a gas impermeable cover layer overlying the absorbent layer and the transmission layer, the cover layer comprising an orifice connected to the transmission layer; and

at least one element configured to reduce the rate at which wound exudate moves towards the orifice when a negative pressure is applied at the orifice.

According to another embodiment of the present disclosure there is provided a method of applying TNP at a wound site, comprising:

- applying negative pressure at an orifice of a cover layer of a wound dressing comprising any of the components or

7

features of any wound dressing embodiment disclosed herein, a peripheral region around the wound site being sealed with the wound dressing such that air and wound exudate move towards the orifice;

collecting wound exudate, from the wound site, through a transmission layer of the wound dressing, in an absorbent layer of the wound dressing; and
reducing the rate at which wound exudate moves towards the orifice.

According to still another embodiment of the present disclosure there is provided an apparatus for dressing a wound for the application of topical negative pressure at a wound site, comprising a wound dressing comprising any of the components or features of any wound dressing embodiment disclosed herein and/or:

an absorbent layer for absorbing wound exudate;
a gas impermeable cover layer overlying the absorbent layer the cover layer comprising at least one orifice configured to allow negative pressure to be communicated through the cover layer in at least two spaced apart regions.

According to an additional embodiment of the present disclosure there is provided a method of applying TNP at a wound site, comprising:

sealing a cover layer of a wound dressing comprising any of the components or features of any wound dressing embodiment disclosed herein around the wound site;
applying negative pressure at at least one orifice in the cover layer, said at least one orifice configured to allow negative pressure to be communicated through the cover layer in at least two spaced apart regions; and
collecting wound exudate, from the wound site, in an absorbent layer of the wound dressing.

According to another embodiment of the present disclosure there is provided a suction port for applying negative pressure to a wound dressing of any of the embodiments disclosed herein or having any of the components or features of any wound dressing embodiment disclosed herein for the application of topical negative pressure at a wound site, the suction port comprising:

a connector portion for connecting the suction port to a source of negative pressure;
a sealing surface for sealing the suction port to a cover layer of a wound dressing; and
a liquid impermeable gas permeable filter element arranged to prevent a liquid entering the connector portion.

According to an additional embodiment of the present disclosure there is provided a method of communicating negative pressure to comprising a wound dressing of any of the embodiments disclosed herein or having any of the components or features of any wound dressing embodiment disclosed herein for the application of topical negative pressure at a wound site, comprising:

applying negative pressure at a connecting portion of a suction port sealed around a perimeter of an orifice in a cover layer of the wound dressing;
filtering gas drawn from within the wound dressing through a liquid impermeable gas permeable filter element of the suction port.

According to another embodiment of the present disclosure there is provided a method of manufacturing a suction port for applying negative pressure to a wound dressing for the application of topical negative pressure at a wound site, the suction port having a connector portion for connecting the suction port to a source of negative pressure and a sealing surface for sealing the suction port to a cover layer

8

of a wound dressing of any of the embodiments disclosed herein or having any of the components or features of any wound dressing embodiment disclosed herein, the method comprising:

disposing a liquid impermeable gas permeable filter element of the suction port at a location to prevent a liquid entering the connector portion.

According to yet another embodiment of the present disclosure there is provided an apparatus for the application of TNP therapy to a wound site, comprising:

a first layer comprising a plurality of openings each having a first open area;
a further layer spaced apart from the first layer comprising a plurality of further openings each having a further open area; and
an air impermeable, moisture vapor permeable cover layer over the first and further layers; wherein a region between the first and further layers comprises a portion of a flow path for air and/or wound exudate flowing from a wound site and said first open area is less than said further open area.

According to still another embodiment of the present disclosure there is provided a method of applying TNP therapy to a wound site, comprising:

via a vacuum pump in fluid communication with a wound dressing of any of the embodiments disclosed herein or having any of the components or features of any wound dressing embodiment disclosed herein located over a wound site, applying a negative pressure at the wound site; and
as liquid evaporates through a cover layer of the dressing, preventing blockage of a fluid flowpath region of the wound dressing.

Some embodiments provide a wound dressing of any of the embodiments disclosed herein or having any of the components or features of any wound dressing embodiment disclosed herein which even when under negative pressure conditions is able to provide further "give" to buffer compression forces from harming a wound.

Some embodiments provide a wound dressing of any of the embodiments disclosed herein or having any of the components or features of any wound dressing embodiment disclosed herein able to disconnect shear forces applied to the dressing from the wound site covered by the dressing. As a result damage to the wound can be wholly or at least partially avoided.

Some embodiments provide the advantage that a wound site can be covered with a wound dressing of any of the embodiments disclosed herein or having any of the components or features of any wound dressing embodiment disclosed herein which is simultaneously able to deliver negative pressure wound therapy to a wound site, collect exudate and provide protection from forces operating on the dressing.

Some embodiments provide the advantage that forces operating on a wound dressing of any of the embodiments disclosed herein or having any of the components or features of any wound dressing embodiment disclosed herein can be offset by dissipating loads operating over a relatively small distance on an upper layer of the dressing to a relatively larger area on a lower surface of the dressing. The force is thus dissipated over a larger area thus reducing the effect of the force.

Some embodiments provide the advantage that a wound dressing of any of the embodiments disclosed herein or having any of the components or features of any wound dressing embodiment disclosed herein can be used to collect

wound exudate generated during a negative pressure therapy process, whilst extending the useful lifetime of the dressing by transpiring a water component of the wound exudate. A pump remote from the wound dressing can be connected to the wound dressing and reused whilst the wound dressing itself is used to collect wound exudate and may then be disposed of after use.

Some embodiments provide a wound dressing and/or method of applying topical negative pressure in which a flowpath through a wound dressing of any of the embodiments disclosed herein or having any of the components or features of any wound dressing embodiment disclosed herein is kept open so that therapy can be continued for as long as desired by a care giver.

Some embodiments prevent solid material, which may cause a blockage, from entering a flowpath region in a wound dressing of any of the embodiments disclosed herein or having any of the components or features of any wound dressing embodiment disclosed herein by using a layer of the dressing to act as a bar to such material.

Some embodiments prevent build-up of solid material in a flowpath region of a wound dressing of any of the embodiments disclosed herein or having any of the components or features of any wound dressing embodiment disclosed herein by ensuring that any solid material that enters into that flowpath region can always escape into a further region of the dressing.

Some embodiments provide the advantage that the build-up of solid material in a flowpath in a wound dressing of any of the embodiments disclosed herein or having any of the components or features of any wound dressing embodiment disclosed herein is avoided by having an absorbent layer close to the flowpath region store liquid over time. This helps keep the environment of the flowpath region moist which helps avoid crusting.

Some embodiments provide the advantage that a wound dressing of any of the embodiments disclosed herein or having any of the components or features of any wound dressing embodiment disclosed herein can be used to collect wound exudate generated during a negative pressure therapy process, whilst extending the useful lifetime of the dressing by transpiring a water component of the wound exudate. A pump remote from the wound dressing can be connected to the wound dressing and reused whilst the wound dressing itself is used to collect wound exudate and may then be disposed of after use.

Embodiments of the present disclosure are further described hereinafter with reference to the accompanying drawings, in which:

FIG. 1 illustrates a view through an embodiment of a wound dressing of the present disclosure;

FIG. 2a illustrates a plan view of the dressing of FIG. 1;

FIG. 2b illustrates a perspective view of the dressing of FIG. 1;

FIG. 3 illustrates 2 known dressings (a) and (b) and an embodiment of a dressing (c) of the present disclosure;

FIG. 4 illustrates a graph of odour capture ability of various wound dressings;

FIG. 5 shows photographs of a prior art dressing and an embodiment of a dressing of the present disclosure;

FIG. 6 shows photographs of a prior art dressing and an embodiment of a dressing of the present disclosure over time;

FIG. 7 shows a photograph of an embodiment of a dressing of the present disclosure applied to a patient;

FIG. 8 illustrates a graph of the results of tests monitoring lifting of dressings over time;

FIG. 9 illustrates a graph of the percentage of compression of various dressings after a known force was applied to each dressing;

FIG. 10 illustrates the contact area where force is applied after a point pressure is applied to various dressings;

FIG. 11 illustrates various obscuring elements;

FIG. 12a illustrates an alternative dressing arrangement;

FIG. 12b illustrates another dressing arrangement;

FIG. 12c shows a photograph of a yet further dressing arrangement;

FIG. 13 illustrates a graph of pressure transfer through various dressings; and

FIG. 14 illustrates UV-visible spectrum absorbency of various materials.

FIG. 15A illustrates an embodiment of a wound dressing;

FIG. 15B illustrates another embodiment of a wound dressing;

FIG. 16 illustrates a top view of an embodiment of a wound dressing;

FIG. 17 illustrates a top view of an embodiment of a wound dressing embodiment, which can be any dressing embodiment disclosed herein, including baffle elements;

FIG. 18 illustrates a top view of a further wound dressing embodiment, which can be any dressing embodiment disclosed herein, including baffle elements;

FIG. 19 illustrates a baffle element according to one embodiment;

FIG. 20 illustrates a top view of an embodiment of a wound dressing, which can be any dressing embodiment disclosed herein, including a single baffle element;

FIG. 21 illustrates a top view of an embodiment of a wound dressing, which can be any dressing embodiment disclosed herein, including an air channel;

FIG. 22 illustrates a top view of an embodiment of a wound dressing, which can be any dressing embodiment disclosed herein, including two air channels;

FIG. 23 illustrates a top view of an embodiment of a wound dressing, which can be any dressing embodiment disclosed herein, including two orifices in a cover layer coupled through a fluid communication passage;

FIG. 24 illustrates an embodiment of the fluid communication passage;

FIG. 25 illustrates a top view of a suction port;

FIG. 26 illustrates a suction port including a filter element;

FIG. 27 illustrates a further suction port including a filter element;

FIGS. 28A-L illustrate a range of exemplifying configurations of baffle elements in a wound dressing, which can be any dressing embodiment disclosed herein;

FIG. 29 illustrates an exemplifying configuration of vias in a transmission layer of a wound dressing, which can be any dressing embodiment disclosed herein;

FIG. 30 illustrates a top view of a wound dressing, which can be any dressing embodiment disclosed herein, including an elongate orifice in a cover layer;

FIG. 31 illustrates a transmission layer in a relaxed mode of operation;

FIG. 32 illustrates a transmission layer in a forced mode of operation;

FIG. 33 illustrates pressure offsetting;

FIG. 34 illustrates a transmission layer and overlying absorbent layer in a relaxed mode of operation;

FIG. 35 illustrates an absorbent layer and transmission layer experiencing a compressive force;

FIG. 36 illustrates an absorbent layer and transmission layer experiencing a shear force;

FIG. 37 illustrates a cross-section of a region of an embodiment of a wound dressing;

FIG. 38 illustrates a lower layer of a transmission layer used in an embodiment of a wound dressing, which can be any dressing embodiment disclosed herein;

FIG. 39 illustrates an upper layer of a transmission layer used in an embodiment of a wound dressing, which can be any dressing embodiment disclosed herein;

FIG. 40 illustrates a lower surface of a transmission layer used in another embodiment of a wound dressing, which can be any dressing embodiment disclosed herein;

FIG. 41 illustrates an upper surface of a transmission layer used in another embodiment of a wound dressing, which can be any dressing embodiment disclosed herein;

FIG. 42 illustrates an embodiment of a wound treatment system; and,

FIGS. 43A-D illustrate the use and application of an embodiment of a wound treatment system onto a patient which can be used with any dressing embodiment disclosed herein.

In the drawings like reference numerals refer to like parts.

Throughout this specification reference is made to a wound. It is to be understood that the term wound is to be broadly construed and encompasses open and closed wounds in which skin is torn, cut or punctured or where trauma causes a contusion. A wound is thus broadly defined as any damaged region of tissue where fluid may or may not be produced. Examples of such wounds include, but are not limited to, incisions, lacerations, abrasions, contusions, burns, diabetic ulcers, pressure ulcers, stoma, surgical wounds, trauma and venous ulcers or the like. The wound dressing may be used for a human or other living being.

In some embodiments, it may be preferable for the wound site to be filled partially or completely with a wound packing material. This wound packing material is optional, but may be desirable in certain wounds, for example deeper wounds. The wound packing material can be used in addition to the wound dressing. The wound packing material generally may comprise a porous and conformable material, for example foam (including reticulated foams), gauze or a hydrofibre ribbon. Preferably, the wound packing material is sized or shaped to fit within the wound site so as to fill any empty spaces. The wound dressing may then be placed over the wound site and wound packing material overlying the wound site. As used herein the term 'exudate' is used to broadly cover any of wound exudate (such as cells, infection by products, cellular debris, proteins, etc.), blood or any other matter released from a wound.

As an overview, the present disclosure relates to an absorbent dressing, where the particular layers provide individual properties to the dressing, and where the combination of these layers in a particular order provides additional properties.

Below are described several properties of such a multi-layered dressing, which can be incorporated independently or in combination with each other.

(a) Dressing pad assembly with layers arranged so that odour control is placed between two layers of different rates of absorptions. This forces the fluid through the odour control layer, but ensures it does not remain saturated with fluid, which enables it to remain efficient.

Odour control can also be achieved by incorporating odour-control materials within some of the other layers of the pad.

Differential absorption also helps to limit the risk of maceration close to the skin, as the foam layer (closest to the wound) is drained of its excess fluid by the superabsorber

layer (on the other side of the odour control layer). The superabsorber layer does not allow fluid to be released in liquid form under compression, and fluid can only leave this layer by evaporation, or wicking transfer to a further layer.

5 The superabsorber layer can be shaped to a larger size than the lowest pad layer, to ensure adequate protection against potential leaks by providing a highly absorbent zone at the very edge of the pad. This can also be achieved by including a ring of highly absorbent material superimposed on the pad assembly.

(b) Dressing containing a means of partially obscuring the top surface. The effect is to reduce the visibility of unsightly exudates while allowing clinical judgment on the state of the dressing. This is currently achieved by using a visual masking layer, where overlapping fabrics with openings are disposed slightly offset of each other, for example. While this method allows fluid to wick up through this layer and reach the top film, coloured solids remain onto the layer below, thus containing the coloured solid matter at a little distance from the top film and providing a reduced aesthetics impact.

(c) A dressing design that has enhanced compatibility with body movement by means of:

25 Using pad components which can deform plastically under the pressures used to apply dressings (unlike purely foam dressings which tend to apply tension forces to resume their as initial flat shape) and retain the shape they have been given around a part of the body

30 Having no, or minimal, means of bonding the layers together, to ensure that the dressing composition does not offer resistance to movement by providing resistance to internal shear

A larger border to increase article retention, and the area of elastic stretch that can follow the movement of the skin

Shaping the dressing such that sub-areas of the pad can move independently from each other without compromising the overall position or integrity of the dressing

40 Using different dimensions of the pad components to minimise the angle of incidence of the dressing edge, which links to reduced resistance to rubbing onto textile

These can be used individually or in combination of any number, however the effect is maximised by using all options in one embodiment.

(d) A dressing pad design that provides enhanced protection against mechanical forces, both from the outside (shocks, knocks, shear) and the inside (pressure onto wounds from bony protrusions).

Protection against the ill effects of direct pressure can be achieved by incorporating, in the structure of the dressing, a means of spreading a point pressure into a proportionally lower pressure across a larger surface area.

55 In particular, the use of three-dimensional knits, such as spacer fabrics, can provide the desired effect. The vertical filaments bonding two horizontal knitted layers can help to initially resist collapse of the dressing structure, and spreading of the pressure across a wider area than that of the point force applied. The yield point at which the dressing collapses completely can therefore be seen at higher forces than what traditional foam dressings can withstand.

Pressure distribution maps can also show that such a 3-D structure can spread a point force to a wider area than a foam layer of the same thickness can.

Protection against shear can be achieved by ensuring that the components of the dressing can themselves shear com-

pared to each other: this can diminish what shear forces are being transmitted through to the skin or the wound.

(e) A dressing pad assembly where the following properties are being provided by given material layers, and where the respective position of these layers provides additional properties on top of those from the individual layers. The description below describes the pad composition from the side closest to the wound (i) to the side furthest from the wound (v):

i. Initial fluid uptake into the dressing pad, through a wound contact layer, via a soft, hydrophilic polyurethane foam layer (reduced risk of maceration, comfort, maintain moist wound healing environment)

ii. Odour-control of the fluid taken up via a layer of activated charcoal cloth, which performs in a wet state (odour control)

iii. Transfer of fluid through this odour-control layer and onto an absorbent layer, which does not release the fluid back out in liquid form (reduced risk of maceration, maintain moist wound healing environment)

iv. Impact and shear protection through a three-dimensional knitted fabric, which offers resistance to pressure transfer onto the wound (shock and knock protection)

v. Partial masking of the uppermost surface of the pad through a semi-opaque component (enhanced aesthetic appearance during wear, allowing clinical judgement)

Combination of (ii) and (iii) enhances the odour control capability, as this helps to reduce the fluid saturation of the odour control layer and maximise its efficacy.

Combination of (iii), (iv) and (v) to ensure that fluid is being evaporated from the superabsorber layer, out of the dressing through the moisture-vapour permeable top film.

For all the dressing pads described (a) to (e), the pad is contained between a wound contact layer and a top film.

The wound contact layer can comprise a perforated wound-side adhesive which can be a silicone adhesive, or a low-tack adhesive to minimise skin trauma on removal. The wound contact layer comprises a support material which can be a mesh, a net or a perforated film. It can also comprise a construction adhesive on the pad side, to ensure its intimate contact with the lowest part of the pad, and therefore efficient uptake of fluid from the wound without pooling.

The top film is a liquid-impermeable, moisture-vapour permeable, breathable film, which allows moisture to evaporate from the dressing.

FIGS. 1, 2a and 2b respectively show a schematic cross-sectional view, a plan view and a perspective view of a wound dressing according to an embodiment of the present disclosure. The wound dressing **100** includes a number of layers that are built up in a generally laminar fashion to form a dressing having a relatively planar form. The wound dressing **100** includes a border region **110** extending around the outer periphery of the dressing and a raised central region **112** in the centre of the dressing (in plan view). The precise dimensions of the border region and the central region may be predetermined to suit a particular wound or particular wound type. There may be no border region required. Here the border region has the general function of providing an area for sealingly engaging with a patient's skin surrounding a wound site to form a sealed cavity over the wound site. The central region is the location of further functional elements of the wound dressing.

The dressing **100** includes a perforated wound contact layer (**101**) and a top film (**102**).

Further components of the wound dressing **100** include: A layer of polyurethane hydrocellular foam (**103**) of a suitable size to cover the recommended dimension of wounds corresponding to the particular dressing size chosen

A layer of activated charcoal cloth (**104**) of similar or slightly smaller dimensions than (**103**), to allow for odour control with limited aesthetic impact on the wound side.

A layer of superabsorbent air-laid material (**105**) containing cellulose fibres and a superabsorbent polyacrylate particulates, of dimensions slightly larger than (**103**) to allow for an overlap of superabsorbent material acting as leak prevention

A layer of three-dimensional knitted spacer fabric (**106**), providing protection from pressure, while allowing partial masking of the top surface of the superabsorber, where coloured exudate would remain. In this embodiment this is of smaller dimension (in plan view) than the layer (**105**), to allow for visibility of the edge of the absorbent layer, which can be used by clinicians to assess whether the dressing needs to be changed.

In this embodiment the wound contact layer **101** is a perforated polyurethane film that is coated with a skin-compatible adhesive, such as pressure sensitive acrylic adhesive or silicone adhesive (not shown). Alternatively the wound contact layer may be formed from any suitable polymer, e.g. silicone, ethylvinyl acetate, polyethylene, polypropylene, or polyester, or a combination thereof. The skin-compatible adhesive is coated on the lower side of the layer **101**, i.e. the side that is to contact the patient. Aptly the adhesive is coated as a continuous layer on the underside of the layer **101**. Optionally the adhesive may be coated in a semi-continuous layer such as in a pattern such as a checkerboard pattern, polka dot pattern, herring bone pattern, mesh pattern or other suitable pattern.

Alternatively the adhesive may be coated around a border region **110** of the dressing only, and not in a central region **112** of the dressing (as viewed from above in plan view) such that the adhesive may adhere to skin surrounding a wound and not the wound itself. The perforations allow the wound contact layer to be permeable to liquid and gas. The perforations are through holes extending from an upper surface to a lower surface of the wound contact layer to enable fluid to flow through the layer. The perforations are small enough to help prevent tissue ingrowth into the wound dressing yet still allow fluid to flow. The perforations may be slits or holes having a size range of 0.025 mm to 1.2 mm for example. The upper surface of layer **101** may optionally be coated with adhesive, to help in the construction of the dressing. Aptly the adhesive may be a pressure sensitive adhesive and aptly the same adhesive as used on the lower surface of the layer **101**.

The absorbent layer **103** of polyurethane hydrocellular foam is located over the wound contact layer **101** and extends over the central region **112** of the wound contact layer.

The term hydrocellular is a term given to foams that are absorbent, hydrophilic and polymeric. The foams may have a particular range of cell size of 30 microns to 700 microns.

The foam is in this case of polyurethane, hydrophilic, conformable, resilient, and porous and allows fluids such as wound exudate to be drawn away from the wound site and further into the dressing. However, the foam also maintains a sufficiently moist wound healing environment so as to not dry out the wound, retaining a balanced moist atmosphere under the dressing. An optimal wound healing environment

generally requires the area of the wound to have some level of moisture yet without excessive fluid.

The absorbent employed in the absorbent layer of the dressings may be any suitable polymer foam. The foam is aptly a highly conformable hydrophilic foam, aptly an open celled foam, and more aptly the foam is a mixture of open and closed cells.

The absorbent layer used in dressings of the present disclosure is capable of absorbing wound exudate. It is desirable that the foam layer absorbs the wound exudate rapidly.

Such rapid absorption prevents undesirable pooling of exudate between the dressing and the wound.

The ability of polymer foam layers to absorb and retain fluids depends to some extent on the size of the foam cells, the porosity of the foam and the thickness of the foam layer. Suitable open cell foams of dressing embodiments of the present disclosure have a cell size of 30 microns to 700 microns and aptly a cell size of 50 microns to 500 microns. Apt open cell hydrophilic foams of dressings of the present disclosure have 20% to 70% and preferably 30% to 60% of the total membrane area of the cells as membrane openings. Such open cell foams permit transport of fluid and cellular debris into and within the foam.

Apt foams may be polyurethane, carboxylated butadiene styrene rubber, polyacrylate or the like foam. Such foams may be made of hydrophilic materials per se or may be treated to render them hydrophilic, for example with surfactants. It is preferred to use foams that are made of polymer that is itself hydrophilic as it has been found the exudate is less likely to coagulate rapidly. Favoured hydrophilic polymer foams are hydrophilic polyurethane and especially those which are made of crosslinked hydrophilic polyurethane. Preferred foams can be made by reacting a hydrophilic isocyanate terminated polyether prepolymer with water. Suitable hydrophilic polyurethane foams of this type include those known as Hypol™ foams. Hypol™ foams can be made from Hypol hydrophilic prepolymers marketed by W. R. Grace and Co and are hydrophilic cellular foams having a mixture of open and closed cells. Hypol™ based foams are also available from Dow Chemicals. Other suitable foams are described in WO91/01706 in relation to the absorbent layer described, incorporated herein by reference, and in WO93/04101 also incorporated herein by reference.

The use of such foams of hydrophilic polymer in the absorbent pad of dressings of the present disclosure can allow the wound to be maintained in a moist condition even when the exudate produced has been absorbed and removed from the wound surface.

A further function of the foam layer is to wick away excess fluid from the wound area via its open cells. It is noted that PU foam itself can absorb liquid, the whole polymer swelling.

The odour-removing layer of activated charcoal cloth **104** is provided over the layer of foam **103**. In this embodiment the activated charcoal layer is about the same length and depth as the foam layer and therefore lies over the foam layer to cover about the same area. The layer may be of Zorflex® cloth available from Chemviron Carbon, for example. Alternative suitable materials are manufactured by MAST under the trade name C-TeX®.

The function of the odour-removing layer is to help prevent or reduce odour originating from the wound from transmitting out of the dressing.

It is noted that in this example the odour-removing layer is provided as a loose layer, unbonded to the adjacent layers, though alternatively the layers may be bonded by adhesive or stitching, etc.

The layer of absorbent material **105** is provided over the odour-removing layer **104**. The absorbent layer **105** extends fully over the layer **104**, as well as over the side portions of both the odour-removing layer **104** and foam layer **103**. The absorbent material may be a foam, woven or non-woven or knitted natural or synthetic material and may optionally include or be super-absorbent material. A suitable material may be an air-laid material containing cellulose fibres and superabsorbent polyacrylate particulates or fibres, for example superabsorbent cores available from Novathin. Alternatively the absorbent layer **105** may be manufactured from ALLEVYN™ foam, Freudenberg 114-224-4, Chem-Posite™ 11C-450, CMC (e.g. Medline Maxsorb with Alginate), alginate (e.g. ActivHeal Alginate by Advanced Medical Solutions) and/or polyacrylate fibres (e.g. SAF™ by Technical Absorbent Ltd).

The layer **105** forms a reservoir for fluid, particularly liquid, removed from the wound site and draws those fluids towards a cover layer **102**. The material of the absorbent layer also prevents liquid collected in the wound dressing from flowing freely once in the dressing structure. The absorbent layer **105** also helps distribute fluid throughout the layer via a wicking action so that fluid is drawn from the wound site and stored throughout the absorbent layer, i.e. transferring and locking in the liquid. This prevents agglomeration in areas of the absorbent layer. The capacity of the absorbent material should be sufficient to manage the exudate flow rate of a wound for the predetermined life of the dressing, whether the wound is acute or chronic. Again, in combination with the foam layer, the layer **105** aptly should not cause the wound to become completely dry. This might occur if, for example, the superabsorbent material were to dry out the foam layer and then subsequently the wound area.

Aptly, the absorbent layer is a layer of non-woven cellulose fibres having super-absorbent material in the form of dry particles dispersed throughout. Use of the cellulose fibres introduces fast wicking elements which help quickly and evenly distribute liquid taken up by the dressing. The juxtaposition of multiple strand-like fibres leads to strong capillary action in the fibrous pad which helps distribute liquid. In this way, the super-absorbent material is efficiently supplied with liquid. Also, all regions of the absorbent layer are provided with liquid.

The absorbent layer **105** aptly has a high osmotic potential so as to prevent liquid being released from the layer, even when the layer is under compression (e.g. if the dressing area is pressed or leant on). Liquid may however leave the layer by diffusion through evaporation or possibly wicking transfer to a further layer.

The layer of absorbent material **105** may be of any suitable dimensions. Aptly, if the layer is shaped to a size larger than the layers between itself and the wound contact layer, then the layer can fold over the edges of any intermediate layers, acting as an enclosure such that any fluid moving into the dressing will encounter the absorbent layer prior to encountering the top film or the adhesive wound contact layer. This helps to prevent possible leaks of fluid from the dressing. As an alternative, a ring shaped (annular or torus) or other suitable border shaped portion of absorbent material may be added to a dressing separately from the

absorbent layer to surround underlying layers and to perform the same function as the overlying edge of the absorbent layer.

Optionally, according to certain embodiments of the present disclosure, the absorbent layer may include synthetic staple fibres and/or bi-component staple fibres and/or natural staple fibres and/or super-absorbent fibres. Fibres in the absorbent layer may be secured together by latex bonding or thermal bonding or hydrogen bonding or a combination of any bonding technique or other securing mechanism. Aptly, the absorbent layer is formed by fibres which operate to lock super-absorbent particles within the absorbent layer. This helps ensure that super-absorbent particles do not move external to the absorbent layer and towards an underlying wound bed.

Aptly, the fibres are strand-like and made from cellulose, polyester, viscose or the like. Aptly, dry absorbent particles are distributed throughout the absorbent layer ready for use. Aptly, the absorbent layer comprises a pad of cellulose fibres and a plurality of super absorbent particles. Aptly, the absorbent layer is a non-woven layer of randomly orientated cellulose fibres.

Super-absorber particles/fibres may be, for example, sodium polyacrylate or carbomethoxycellulose materials or the like or any material capable of absorbing many times its own weight in liquid. Aptly, the material can absorb more than five times its own weight of 0.9% W/W saline, etc. Aptly, the material can absorb more than 15 times its own weight of 0.9% W/W saline, etc. Aptly, the material is capable of absorbing more than 20 times its own weight of 0.9% W/W saline, etc. Aptly, the material is capable of absorbing more than 30 times its own weight of 0.9% W/W saline, etc.

Aptly, the particles of superabsorber are very hydrophilic and grab the fluid as it enters the layer, swelling up on contact. An equilibrium is set up within the dressing core whereby moisture passes from the superabsorber to the top film and the fluid vapour starts to be transpired. A moisture gradient may be established within the dressing to continually remove fluid from the wound bed.

The shielding layer **106** is a layer having a 3-dimensional structure that may include open cell foam (e.g. Alleyvn™ foam by Smith & Nephew, Biatain foam by Coloplast or Advanced Medical Devices' ActivHeal foam), a knitted or woven spacer fabric (for example Baltex 7970 weft knitted polyester or Baltex XD spacer fabric or Surgical Mesh's Polyester felt or Polyester mesh) or a non-woven fabric (e.g. Fiberweb's S-tex or Securon). Alternatively the shielding layer may be a completely opaque polymer film having cut-out windows or perforations, for example (e.g. SNEF's H514 or H518 blue net). Here the layer **106** is of polyester that includes a top layer (that is, a layer distal from the wound in use), which is a 84/144 textured polyester, a bottom layer (that is, a layer that lies proximate to the wound in use), which is a 100 denier flat polyester and a third layer formed sandwiched between these two layers, which is a region defined by a knitted polyester viscose, cellulose or the like monofilament fibre. Of course other materials and other linear mass densities of fibre could be used, including for example a multistrand alternative. The shielding layer **106** may be similar or identical to the materials described in US2011/0282309 in relation to the transmission layer (FIGS. 23 to 27).

The layer **106** allows the transmission therethrough of any gas or vapour to the top film **102** and may therefore be considered as a transmission layer.

Aptly the layer **106** performs one or more further functions including acting as a partial masking layer and acting as a force distributing (impact protection) layer.

Partial masking of wound exudate, blood or other matter released from a wound may be achieved with overlapping perforated fabrics disposed somewhat offset from each other, such as shown in FIG. 11(b). As shown in (b), a shielding layer is itself formed from 3 sub-layers, such as the 3-D knit material described above. The perforated top and bottom layers allow transport of vapour and gas, and are offset from gas pathways in the central knitted layer. As such, vapour and gas may travel through the layer, but the coloured exudate cannot be seen, or travel, through the layer.

Alternatively, as shown in FIG. 11(a), a perforated cover layer **1102** is provided over a perforated shielding layer **1106**, which allows moisture vapour and gas to be transmitted away from the dressing, yet provides sufficient masking for exudates to be visible only to a trained clinician.

More specifically, it is known that when a film is breathable (able to transmit vapour), then it is likely to allow colour to transmit therethrough. Even if a breathable film includes a coloured pigment for masking a lower layer, when exudate fluid contacts the film, coloured elements in the exudate can be carried into contact with the film and change the colour perception from the film, and be visible to the user. This allows fluid to transmit through the layer towards the top film whilst coloured solids or liquids remain bound in the absorbent layer below. Exudate colour is principally due to proteins and biological break down products from tissue or blood cells, which tend to be large molecules.

Another function of the shielding layer **106** may be for pressure distribution and impact protection. For example, if the patient accidentally knocks the wound area, leans on the wound area or another cause applies a pressure to the dressing covering a wound. Aptly the shielding layer is provided closer to where the pressure is being applied than other layers of the dressing.

The shielding layer **106** acts as a pressure spreading component, receiving a pressure on one side thereof (possibly a point force) and spreading the pressure over a wider area, thus reducing the relative pressure received on the other side of the shielding layer. As such, the level of pressure felt by the patient at the wound site is reduced.

A form of shielding layer that has been found to be a good pressure distributed is a layer having non-ordered fibres or strands, i.e. fibres lying at different angles with respect to each other, for example the knitted spacer fabric of Baltex 7970.

The absorbent layer **105** may also act as a pressure spreading component. A combination of the shielding layer **106** and the absorbent layer **105** has been found to give particularly apt pressure distributing properties. However, only one pressure spreading component may be sufficient.

In general, a material that is relatively non-deformable is more suitable for spreading point pressure. However this should be balanced by the requirement for deformation ability for the dressing to adhere to a non-planar body part.

When a pressure occurs from inside the patient's body, such as pressure from a protruding bone, the shielding layer may be somewhat less efficient at spreading the pressure if it is positioned towards the distal part of the dressing. However, any equal and opposite reaction of force acting back toward the patient's skin will be spread by the shielding layer **106** and absorbent layer **105** (e.g. if the patient is laying on something hard such as the ground or hard chair). The pressure spreading response will depend somewhat

upon the hardness of the surface against which the patient and dressing are pressed against, if any.

The pressure spreading ability of these layers may also be useful against slower, constant pressures as well as rapid point forces.

The top film **102** is a cover layer for covering the lower layers of the dressing, helping to encapsulate the layers between the wound contact layer and the top film. The top film **102** is in this case a layer of polyurethane, Elastollan (trade name) SP9109 manufactured by BASF. The top film may be coated with any suitable adhesive. Aptly the adhesive will be a pressure sensitive adhesive e.g. acrylic adhesive or silicone adhesive.

As such, the top film **102** helps to ensure that the dressing remains breathable, i.e. allows a proportion of fluid absorbed in the dressing to be evaporated via the outer surface of the dressing. In this way certain fluid content of the exudate can be transpired from the dressing, reducing the volume of remaining exudate and increasing the time before the dressing becomes full. Also, the wound contact layer **101** and top cover **102** help to ensure that the border region **110** of the dressing remains breathable, i.e. allows a patient's normal skin perspiration to be evaporated through the dressing, which helps in preventing or minimising skin maceration.

The outer layer of dressings of the present disclosure when present can be a continuous conformable film. The continuous moisture vapour transmitting conformable film outer layer of the wound dressing may be used to regulate the moisture loss from the wound area under the dressing and also to act as a barrier to bacteria so that bacteria on the outside surface of the dressing cannot penetrate to the wound area. Suitable continuous conformable films will have a moisture vapour transmission rate of at least 300, aptly from 300 to 5000 grams preferably 500 to 2000 grams/square meter/24 hrs at 37.5 C at 100% to 10% relative humidity difference. Such moisture vapour transmission rate of the continuous film allows the wound under the dressing to heal under moist conditions without causing the skin surrounding the wound to macerate. To ensure the use of an adhesive on the top film **102** does not reduce the moisture vapour transmission rate, a hydrophilic water dispersible adhesive may be used e.g. hydrophilic acrylic adhesives. Although, other suitable adhesive may also be used. Aptly adhesive may also be spread across the surface of the film in the form of a pattern such that a portion of the area of the film does not contain adhesive. E.g., use of a polka dot pattern whereby adhesive is not present in the dot area and 5 to 95%, or aptly 10 to 80%, more aptly 30 to 70%, more aptly 40 to 70%, more aptly 40 to 60%, more aptly 40 to 50% of the area of film does not contain adhesive. It will be apparent to those skilled in the art that any suitable pattern of adhesive layer may be used to produce a top film **102** that is not fully coated with adhesive and thus maximises the moisture vapour transmission rate. Other suitable materials for the cover layer are described in WO91/01706 in relation to the conformable moisture vapour transmitting outer layer.

Additionally, the top film may act as a further barrier to any remaining odour from being transmitted out of the wound dressing, since the top film may include through holes that allow molecules of a predetermined maximum size to pass therethrough.

FIGS. 2a and 2b show a possible shape of a dressing, useful for enhanced compatibility with body movement, where each layer is shaped to reduce the incident angle of the pad edge, and to provide somewhat independently moving sub-sections of the dressing. The dressing border, including the wound contact layer (**101**) and the top film (**102**) can

also comprise slits, provided to further enhance the conformability on application by allowing the borders to overlap if needed.

Reverting back to FIG. 1, it can be seen that the cross-section of the dressing includes various layers stacked in a contiguous manner so as to form a generally laminate structure. Preferably the dressing is moisture vapour permeable. The layers shown in FIG. 1 are of different widths and dimensions, though other arrangements are also possible.

In the border region **110**, the top film **102** abuts with the wound contact layer **101**. A moisture vapour transmitting adhesive layer is provided (not shown) in the border region **110** between the layers **101**, **102** to bond the layers in that region. Suitable adhesives that are moisture vapour transmitting include various acrylate ester copolymer and polyvinyl ether pressure sensitive adhesives for example as described in UK patent number 1280631. Aptly the adhesives may be copolymers of an acrylate ester with acrylic acid for example as described in UK patent application number 2070631.

The dimensions of the components are arranged so as to minimise the angle of incidence of the dressing edge. This helps to reduce rubbing of the dressing against textiles and reduced snagging of the dressing against textile, by reducing the change in profile of the dressing throughout the thickness of the dressing.

In use, a wound dressing as described above would be applied to a wound site of a patient with the surface of the wound contact layer **101** facing the wound site. Any wound exudate, blood or other wound fluid would travel into the dressing via the wound contact layer and sequential layers above the wound contact layer. Fluid would permeate through the foam layer, the activated charcoal layer, and then reach the absorber layer at which point preferably the liquid would not go any further and be retained by the absorber layer. On the other hand, gas and moisture vapour would be able to permeate further via the shielding layer and/or top film.

FIG. 3 shows the difference between the appearance of existing dressings and of a dressing of the present disclosure after use on a wound model. The photographs (a) and (b) are known dressings. The photograph (c) is a wound dressing according to the present disclosure. The region identified by reference number **114** is the area of the central region **112** that is not covered by the shielding layer **106**. As such, the absorbent layer **105** is directly adjacent the top film **102** in this area. Since the shielding layer **106** acts as a partial masking layer, the region **114** may be used by a clinician or other trained user to assess the spread of wound exudate throughout the dressing. This assessment will be helped by the dressing being placed approximately central over a wound such that exudate reaches the radially outer region **114** after the exudate has reached the more central areas (e.g. that covered by the shielding layer **106**). Aptly, the clinician may be trained to assess the spread of wound exudate using the region **114** as a guide, for example with instructions that less than 50% coverage of the region **114** with exudate does not require changing of the dressing, about 50% coverage of the region **114** indicating the time to consider changing the dressing, and more than 50% coverage of the region **114** with exudate does require changing of the dressing. Of course the area of the central region **112** covered with the shielding layer **106**, which acts as a partial masking layer, may also or alternatively be used to assess the spread of exudate by a trained clinician. In addition, the dressing may have various other instructions for use, for example includ-

ing a recommended maximum duration that the dressing may be used, e.g. 7 days, regardless of the assessment of the spread of exudate.

FIG. 4 shows the odour control performance of the present disclosure (Design A) when wet, compared to existing dressings. This was measured by incubating dressing samples with solutions of odorous compounds in vials, for 24 h at 37° C. The headspace of the vials was subsequently measured by gas-chromatography headspace, for the concentration of odorous compounds remaining in the headspace. The efficiency in odour reduction was measured as a percentage remaining compound, compared to a positive control of incubated odorous compound only. Performance across four different compounds was collated in a single measure, represented in FIG. 4. It can be seen that a dressing according to the present disclosure (with the arrangement of FIG. 1) performs very well in removing odour, with less than 5% odour remaining in the headspace. By comparison, foam dressings perform relatively poorer with higher amounts of odour remaining.

FIG. 5 shows the comparative performance of different shapes of dressings when placed on a tube. It can be seen that a dressing according to the disclosure (with the arrangement of FIG. 1), as shown on the right hand side, remains adhered to the tube after 2.5 hours, whilst a conventional dressing as shown in the left hand side lifts away from the tube after the same 2.5 hours.

The wound dressing of the disclosure may be of any suitable shape or form or size. The overall dimensions of the dressing may be, for example, 160 mm diameter, although any total size may be used, and the size may be determined to match particular wound sizes.

In addition, it is noted that the dressing's improved conformability with non-planar (bodily) shapes can be achieved in part by combining a foam with a material that could be only returned to its initial shape by a force higher than that applied onto it by foam. The role of this second material is to remain in the shape it was given at the application of the dressing, despite the forces applied to it by the foam material trying to relax after deformation at application. E.g. airlaid or non woven material with broken or displaced fibres by the initial application force could provide sufficient resistance against pressure of a hydrocellular foam layer (2 to 4 mm).

The inventors have realised that a dressing formed from foam only will tend to revert to its natural position (planar or flat in the case of the foam layers described here). The foam has a 'memory' of how it was cut and manufactured. Thus when foam dressings are applied with adhesive onto non-flat body parts the adhesive must be sufficiently strong to oppose the force of the foam reverting to its original shape.

As shown in FIG. 6, the performance of a dressing in terms of retention of formed shape including a foam layer and a deformable layer, e.g. a layer similar to the absorbent layer 105 (Sample 6b), has been shown to be much improved compared to a dressing that is formed from a foam only (Sample 6a).

That is, sample 6a included a wound contact layer having an adhesive on its 'wound facing' side, a foam layer (such as layer 103) and a cover layer (such as top film 102). Sample 6b included a wound contact layer having an adhesive on its 'wound facing' side, a foam layer (such as layer 103), an absorbent layer (such as layer 105), a shielding layer (such as layer 106) and a cover layer (such as top film 102).

The initial shapes of the two samples shown in FIG. 6 are planar. Upon compressing the samples into a tightly deformed shape (as shown at time 0), the shape of the samples was monitored over time to view any reactive movement by the sample overcoming the force of the adhesive on the wound contact side. After 5 minutes the Sample 6a had returned to its initial planar shape. Sample 6b reverted somewhat back towards its initial shape after 5 minutes, approximately 50% between its initial deformation shape and the planar form. After 24 hours Sample 6b remained non-planar.

It is believed that components of the dressing of the disclosure, such as the absorbent layer or shielding layer, can plastically deform without memory, by components within the layers being displaced or broken to some degree. For example, some of the fibres in the shielding layer may be broken (without overall damage to the dressing). This displacement or breakage is long term or permanent. As such the force of the foam layer of the dressing reverting to its original shape is counteracted by the displaced or broken components within other layers. As such, as long as the force of the foam layer is lower than the force of returning the other layers to a planar position, the dressing will retain its formed (non-planar) shape.

FIG. 7 shows an example of a dressing applied to a human patient, with sub-areas 701_{a-d} applied at different angles relative to each other, and that can move independently of each other. As shown the dressing has been applied to the base of the neck and shoulder region of a patient. This region requires the lobes or subareas to be applied at different angles to each other. It is noted that there is no specific dividing line (such as perforation or other fold line) between the sub areas here.

It can be seen that not only the conformability of the materials of the dressing, but also the discrete sub-areas of the dressing help to keep the dressing adhered to the uneven surface of the patient.

FIG. 8 illustrates the testing of a wound dressing having sub areas compared to a comparative known dressing with square profile. The lift of the dressing, i.e. movement returning back to the original flat, planar shape, was monitored over 7 days on 25 healthy volunteers. That is, 25 volunteers wore one wound dressing according to the disclosure and one rectangular dressing. The dressings were applied to the thighs of each volunteer. For each volunteer, after 1, 3 and 7 days of wearing the dressing, the presence of any lifting of dressing border that had detached away from the skin of the volunteer was determined. The graph indicates the percentage of the number of dressings in total that showed any lifting.

As shown in FIG. 8, it can be seen that the dressing having a shape with four lobes or subareas (as per FIGS. 2a and 2b) performed better than the square shaped dressing. The percentage of the dressings with sub areas that showed any sign of lifting away from the volunteer's skin was on average just over 50% of the dressings after 7 days wear. For the square dressing, the percentage of the dressings showing signed of lifting away from the volunteer's skin was on average 70% of the total after 7 days wear.

The dressing shape has a rotational symmetry about its centre point (in plan view). In this example the dressing has 4 lobes. The shape of the central region 112 matches the shape of the border region 110 such that the width of the border region is approximately equal around the entire dressing. Aptly the border may be between about 12.5 mm and about 29 mm. More aptly the border is about 25 mm. Of course the border size will depend on the full dimensions of

the dressing. Other numbers of lobes may be used such as 3, 5, 6, 7, 8, etc. The isotropic nature of the dressing shape gives the advantage that the user is not required to orientate the dressing in a specific manner before applying the dressing to a wound. The shape also enables the dressing to be adaptable to various parts of the body.

The dressing shape with 4 sub areas (lobes) aptly gives a maximum pad area with respect to the border area, yet has increased flexibility compared to a square dressing.

The inventors also performed tests upon various dressings with respect to the dissipation of force applied to the dressing. FIG. 9 illustrates the degree of (percentage of) compression of a dressing with different force applied. It can be seen that for almost all forces applied (apart from the extreme ends of the scale at 0 to 3 kgf (kilogram-force) and 40 kgf and over where readings show no appreciable difference), dressing compression is higher for a dressing formed from foam only having a thickness of 4 mm, such as the foam materials described for layer 103 (curve a) than for a dressing including a foam layer of thickness 2 mm and a fibrous non-woven material, such as the materials described for layer 105 (curve b) and a dressing including a foam layer of thickness 2 mm and a fibrous non-woven material, such as the materials described for layer 105, and a layer of 3-D knit material such as the materials described for layer 106 (curve c). As can be seen from the graph in FIG. 9, dressing including a layer of 3-D knit material (curve c) gave the lowest percentage compression of dressing over the range of forces applied between 3 kg and 40 kg.

From this it can be concluded that fibrous non-woven materials and 3-D knit materials will help to act against a force applied by dissipating the force and preventing compression of the dressing.

FIG. 10 illustrates the area over which pressure is transferred by different dressings when pressure is applied to the dressing from the point pressure of a 0.8 cm² probe. The area of pressure transferred was measured using a pressure reading mat. This equipment was obtained from Tekscan, and includes an array of thin pressure sensors placed between two relatively thin sheets of plastic. The resulting mat is conformable, and transmits pressure readings from the array through a piece of hardware (I-scan handle), to a computer equipped with the I-scan software. The resulting measurements can be expressed for example as contour maps, value tables, maximum pressure reading for a particular area of the mat, average pressure read over the whole testing area, or contact area over which a pressure was sensed by the mat. Pressure transfer was measured on a dressing including a layer of 3-D knit material (identical to the dressing used giving curve c in FIG. 9) (column 1), a dressing made of non-woven material (identical to the dressing used giving curve b in FIG. 9) (column 2) and a foam dressing (identical to the dressing used giving curve a in FIG. 9) (column 3).

FIG. 13 illustrates tests performed by the inventors on four different wound dressings including a dressing as described above with respect to FIG. 1 (column A). Columns B, C and D show the results for other foam dressings. The graph represents the average pressure measured underneath a dressing (as measured by a Tekscan pressure reading mat and software as described above) when the upper surface of the dressing (non-wound contacting side) is impacted at a speed of 3 m/min by a probe until a pressure of 735 mmHg is applied. The area of pressure application was a 10 mm diameter cylindrical probe, onto which a rubber ball of 6.5 cm diameter was attached. It is estimated that the area over which the rubber ball contacted the top of the dressing was

3% of the total area of the rubber sphere, that is 4 cm². This can be compared to a cylindrical probe of diameter 2.25 cm. A summary of the pressure transferred and the area over which pressure was transferred is shown in Table 1 below.

TABLE 1

Sample	Average pressure transferred (mmHg)	Estimated area over which pressure is transferred (cm ²)
Pressure applied	735	4
Dressing of FIG. 1 (A)	25	12.3
Dressing B (foam composite)	39	10.6
Dressing C (foam)	36	11.7
Dressing D (foam)	31	117

Preferably the dressing area to be tested is of 20 cm² or more when using a cylindrical probe of 10 mm diameter, to ensure that the probe size is not larger than the test sample and to ensure pressure is redistributed efficiently through the sample.

Aptly the pressure spreading layer increases the area over which pressure is transferred by at least 25% of the initial application area and more aptly by at least 50% of the initial application area.

The inventors have found that a combination of materials may, as a composite, increase the area over which pressure is transferred by at least 50%, aptly at least 100%, more aptly at least 200% of the initial application area. An increase in the area over which pressure is transferred of 200%.

Individual components can also be assessed for pressure redistribution from a static test, where a pressure of 736 mmHg is applied statically to various materials. Values obtained are shown in the table below:

TABLE 2

Sample	Average pressure transferred (mmHg)	Area over which pressure is transferred (cm ²)
Pressure applied	736	0.8
Foam	301	1.2
Superabsorbent layer	198	1.8
3D fabric #1	249	1.5
3D fabric #2	173	n/a
Composite dressing	53	6.4

The above-described tests on pressure dissipation suggest that a dressing including a shielding layer such as a 3-D spacer layer and optionally also an absorbent layer give enhanced performance in terms of spreading a pressure applied, and thus should perform better against accidental knocks to the wound site for example, compared to known dressings.

The inventors also performed tests upon various dressings with respect to the masking properties of the dressing. The ability to mask colour may be calculated, for example, by measuring the reduction in absorption of light radiation at particular wavelengths. FIG. 14 illustrates the absorption at various different wavelengths of 3 different samples. The tests utilized a UV-Vis spectrophotometer Jasco with integrating sphere, with a scanning range 340 to 800 nm, bandwidth 5 nm and 1000 nm/sec scanning speed. The data labelled black background represents the extreme of exudate colour (the most colour an exudate might have)—the highest level of radiation absorbed and the least amount of radiation

25

reflected from the sample. The data for white background represents the upper limit for total masking—generally the lowest level of radiation absorbed and the highest level of reflection. Sample 1 was a tinted polymer film placed over a black background, which was judged, not to sufficiently mask the black background (representing wound exudate) satisfactorily. Sample 2 was a sheet of 3-dimensional spacer fabric (Baltex 3D) placed over a black background, and was judged to provide adequate masking of the black background. Sample 3 was a sheet of non-woven material dyed green placed over a black background, and provided complete masking of the black background.

The inventors noted that any wound exudate may have dark yellow, red and/or brown tones. Therefore, to appropriately mask these colours, a masking layer would need to shield light wavelengths of below 600 nm.

Measuring the reduction in absorption of light radiation at particular wavelengths may be performed by calculating:

$$\% \text{ reduction} = \frac{(A_{\text{background}} - A_{\text{sample placed on background}})}{(A_{\text{background}})} \times 100$$

where A is the absorption of light radiation at the particular wavelength.

Using this formula, using light at a wavelength of 460 nm, the percentage of absorption reduction was calculated as shown in Table 3 below.

TABLE 3

Sample	Absorption reduction at 460 nm	Appropriate masking observed
Sample 1	34%	No
Sample 2	77%	Yes - partial
Sample 3	69%	Yes - complete

It has been found that materials that reduce light absorption by about 50% or more will provide enough partial or complete masking of wound exudate (as judged by the inventors). Of course a complete masking element would preferably require a means for a clinician to judge the spread of wound exudate in the dressing below the masking element, e.g. the masking element not completely covering the entire dressing. Alternatively a partial masking element may allow a clinician to judge the spread of exudate in the dressing below without additional means.

It will be understood that the wetting of a masking material (by exudate for example) will also affect the masking performance of the masking element, since hydrophilic materials will allow chromophore-carrying species to travel through them more easily. As such, the absorption reduction rate should also be tested on wet materials.

The inventors also tested the above-mentioned Samples 1, 2 and 3 for their masking properties by measuring CIE L*a*b* values (a known 3-dimensional model for representing colour space). The analysis employed Jasco software using the range 380 to 780 nm, standard observed 2(deg), lightsource D65, colour matching JIS Z8701-1999.

Table 4 below shows the L*a*b* values found when Samples 1, 2 and 3 were respectively placed over a black background. The results for the black background alone and a white background are also shown.

26

TABLE 4

Sample	CIE L*a*b* values recorded			Appropriate masking
	L*	a*	b*	observed?
Black background	0	0	0	n/a
Sample 1 (on black)	36.59	3.76	-1.80	No
Sample 2 (on black)	71.76	-0.20	-1.08	Yes - partial
Sample 3 (on black)	70.64	-0.25	-1.23	Yes - complete
White background	100	0	0	n/a

Generally, samples which lead to an increase in L* value will provide a lighter colour tone than the reference surface, which is the main contributor to masking a dark colour. From the values above, apt partial masking materials will yield an L* value above 50, or more aptly above 70.

However, completely opaque masking layers, such as for example a tinted polymeric film, may cover the area to be masked with a darker tone altogether, in which case the measure of L* is not relevant.

Once again these values should also be considered on wet material, for the reasons stated above.

In addition, the dressing of the disclosure may be arranged to prevent shear stress between layers from causing damage to the dressing. This is because the layers are generally not adhered together, other than the top film 102 and wound contact layer 101 being adhered in the border region 110. Thus even if friction or other energy from shear movement occurs, the energy is dissipated by the layers prior to reaching the patient.

The wound facing surface of a wound dressing may be provided with a release coated protector (not shown in the figures), for example a silicon-coated paper. The protector covers the wound contacting side of the dressing prior to application to a patient, and can be peeled away at the time of use.

Various modifications to the detailed arrangements as described above are possible. For example, dressings according to the present disclosure do not require each of the specific layers as described above with respect to FIG. 1. Dressings may include only one layer, or any combination of the layers described above. Alternatively or additionally, the materials of the layers described above may be combined into a single layer or sheet of material to perform the functions of each layer by a single layer.

As noted above, each of the layers described may be used to give one or more function to the wound dressing. As such, each of the layer materials may be used separately or in any combination such that each material provides the given function.

The wound contact layer described above is an optional layer. If used, a wound contact layer may be of any suitable material, such as polyethylene (or polyurethane as described above) or other suitable polymer, and may be perforated for example by a hot pin process, laser ablation process, ultrasound process or in some other way so as to be permeable to fluids.

Although the dressing described above has been described having a border region and a central region this need not be the case. The dressing may be provided without an adhesive layer for attachment to the skin of a patient. Rather, another means may be provided for locating the dressing at the correct position over a wound, such as adhesive tape or a tied bandage.

The relative widths of the various layers may be all the same or different to those as shown in the figures.

The dressing pad assembly may optionally be arranged with layers so that odour control is placed between two layers of different rates of absorptions. The odour control layer can be a charcoal cloth (knitted, woven, felt, non-woven), or any other textile, foam, gel, net or mesh impregnated with odour-control materials. Such odour control materials can be cyclodextrins, zeolites, ion-exchange resins, oxidising agents, activated charcoal powder. It is also possible to use said odour-control materials dispersed in any layer of the pad assembly, and not as a discrete layer.

The dressing may optionally include a means of partially obscuring the top surface. This could also be achieved using a textile (knitted, woven, or non-woven) layer without openings, provided it still enables fluid evaporation from the absorbent structure. It could also be achieved by printing a masking pattern on the top film, or on the top surface of the uppermost pad component, using an appropriate ink or coloured pad component (yarn, thread, coating) respectively. Another way of achieving this would be to have a completely opaque top surface, which could be temporarily opened by the clinician for inspection of the dressing state (for example through a window), and closed again without compromising the environment of the wound.

The dressing may optionally be arranged such that it has enhanced compatibility with body movement. This could also be achieved using a different shape for the sub-areas, such as diamonds, triangles, or a plurality of such shapes tessellated across the area of the dressing. Alternatively, preferential folding lines may be scored within the thickness of the dressing material, and thus define independent sub-areas for adapting to movement.

Alternatively, the layers could be bonded using an elastic material, such as a viscoelastic adhesive, which would allow shear between the layers but refrain them from becoming separated and shifting across the pad.

A dressing may optionally be arranged that provides enhanced protection against mechanical forces. Other ways of achieving this include:

Incorporation of pressure-relieving components within other layers of the dressing, such as within the foam layer (e.g. moulding the foam around a 3-D structure capable of spreading load)

Incorporation of pressure-absorbing component within other layers of the dressing (e.g. beads of viscoelastic material incorporated in the superabsorbent layer)

A dressing assembly may optionally be arranged where the flowing properties are being provided by given material layers, and where the respective position of these layers provides additional properties on top of those from the individual layers. Alternative arrangement of layers than that described above may still provide some of the properties sought.

For example, placing the shielding layer (106) below the superabsorbent layer (105) would still allow protection from point pressure, but would lose the masking ability of this layer, and would probably affect the transmission of fluid between the foam layer (103) and the superabsorbent layer (105).

Another example is the placement of the odour control layer or component further away from the wound: this can be seen as beneficial because some types of odour control work differently depending on whether they are wet or dry. Placing a colour-less odour control component towards the top of the dressing (anywhere above (105)) could provide

odour control properties without the visual impact that a black layer of charcoal cloth would have.

It can also be envisaged that several properties are combined within one layer, for example superabsorbent and odour control components could be incorporated in the foam structure. The only remaining optional properties to provide in this case would be protection and masking, which could be achieved by placing a layer (106) directly above such a modified foam if needed.

Interestingly, the fluid handling properties of an embodiment where the superabsorbing function is located within the lowest part of the dressing pad may not be as beneficial as those of an embodiment where the functions are held in separate layers, and the fluid is directed from one layer to another.

In another embodiment, the shielding layer 106 is of the same dimensions as 105, and clinical judgment of the exudate spread can be made by observing the spread of exudate through the masking layer. This embodiment has the advantage of completely masking unsightly exudate from the superabsorbent layer.

Alternatively or additionally, the shielding layer can be provided with full masking capability, and windows provided at discrete points of the layer for enabling judgement of the exudate spread below such layer. Examples of such windows are illustrated in FIGS. 12a and 12b. The dressing 1200 shown in FIG. 12a includes a masking layer 1202 and crescent-shaped windows 1204 provided in the masking layer to extend through the layer allowing visibility of the dressing therebelow. The dressing 1210 of FIG. 12b includes a masking layer 1212 and a number of holes 1214 there-through acting as windows for viewing the state of the dressing therebelow. FIG. 12c shows another dressing 1220 including a masking layer 1222 with windows 1224. With the dressings 1200, 1210, 1220 the progress of exudate spread over the dressing and towards the edge of the dressing can be monitored. In other alternatives instructions may be given to change the dressing when the exudate reaches a predetermined distance from the edge of the dressing, such as 5 mm from the dressing edge or 7 mm from the dressing edge, etc. Alternatively a 'traffic light' system may be implemented whereby an electronic indicator shows green, amber or red light to indicate the spread of exudate in the dressing. Alternatively or additionally, another suitable indicator may be used for indicating the spread of exudate over the dressing.

In another embodiment, odour control is not provided by a separate layer (i.e. no layer 104), but instead the odour-control material (activated charcoal, cyclodextrin, ion exchange resin, or other) is dispersed throughout another layer. This can be envisaged within the foam (103), the superabsorbent structure (105), or as a coating onto the masking layer (106).

In addition or alternatively, the obscuring layer may be coated with or formed from a material with size-exclusion properties to help with masking the exudate from view. For example, such a layer could have its lowermost side (the side closer to the wound) coated with materials such as zeolites or clays such as bentonite or sepiolite (the charged surface of which will tend to attract proteins and protein derivatives containing chromophores), other inorganic powders or molecular sieves (e.g. amberlite), proteins (albumin, haemoglobin components with molecular weight 15 to 70 KDa), ionic complexes such as hemes (molecular weight 600 to 850 g/mol), which have the function of immobilising species above a certain size or molecular weight. For example, species having molecular weight above 100 g/mol.

The shielding layer may be coated with or be formed of a hydrophilic compound (e.g. polyesters, polyurethanes, polyureas, polysaccharides, etc.) for assisting in wicking moisture towards the surface of the dressing, helping breathability of the dressing.

The shielding layer may be combined with a cover layer, such as an opaque or dark pigmented top layer.

The shielding layer (acting as a masking layer) may be combined with an absorbent layer, for example by providing an absorbent layer that has been dyed, for example with a dark blue pigment to the fibres of a non-woven or airlaid material.

The shielding layer (acting as a pressure relieving layer) may be combined with an absorbent layer. For example a fibrous superabsorber layer may be provided with a high density of fibres for spreading point pressure. Alternatively a hydrophilic foam may be moulded around pressure-redistributing structures of pillars or arrays of an elastomer material, for example.

Odour control can be combined with absorbency by dispersing particles of activated charcoal or other odour-catching material in a hydrophilic foam at time of reaction, or dispersing it throughout an air-laid material as a powder, or introducing it in the master batch of absorbent polymer used to manufacture fibres which will then be used in an air-laid.

As such, odour control, absorbency and pressure redistribution could be included in a single layer, and if this material was dyed, masking could also be performed.

The layers described herein may each be provided directly adjacent another layer or with further layers therebetween.

A wound dressing may be formed by bringing together a layer of absorbent material with a layer of obscuring material.

Alternatively a wound dressing may be formed by bringing together a layer of absorbent material with a layer of protective material.

Alternatively a wound dressing may be formed by bringing together a layer of absorbent material with a cover layer.

Alternatively a wound dressing may be formed by bringing together a layer of absorbent material with a fluid transmission layer with a layer of activated charcoal material therebetween.

Any of the methods above may include bringing layers together with adhesive over part or all of a layer. The method may be a lamination process.

Alternatively a wound dressing may be formed by bringing together layers as described with respect to FIG. 1, in a contiguous laminar stack, and adhering the top film to the wound contact layer in a border region.

Alternatively a wound dressing may be formed by forming a sheet of material for absorbing wound exudate, the sheet comprising at least one of a foam, an odour capturing material, an absorbent material, and a shielding material for masking or pressure spreading.

The dressing of the disclosure may be manufactured by continuous production techniques. For example, a sheet or sheets of suitable material may be run through rollers to enable the adhesion of one layer to another. Alternatively, pre-cut pad component shapes can be placed onto a web of one of the adhesive film or net components, before being encapsulated by the another adhesive film or net component. Then the dressing may be stamped out by cutting through the material in the desired shape and packaged.

In use, a wound dressing of the present disclosure would be applied to a wound site of a patient with the surface of the wound contacting side of the dressing facing the wound site.

The wound dressing would then be monitored over a predetermined time period to assess the extent of exudate present in the dressing. The dressing may be any of the examples and embodiments described herein.

5 The dressing may be monitored at predetermined intervals or at predetermined time(s) of the day. For example, the dressing may be monitored every 6 hours, or once every morning, lunchtime and evening, for example, or as required by the specific patient.

10 A method for determining the saturation of a wound dressing with wound exudate comprises:

viewing a wound dressing at predetermined intervals to assess the extent of exudate present in the wound dressing.

15 The dressing may be any of the dressings described herein.

With the above-described arrangements one or more advantages over known dressings may be achieved.

20 The disclosure described contains elements which lead to a combination of properties that is not currently being met by existing devices.

In particular, the combination of an effective odour-control layer, held between two absorbent layers of differential absorption power, yields an absorbent structure which does not require a barrier layer to remain efficient against odours.

25 The odour-removing layer is not bonded to adjacent layers. Because of this, the available surface area of active pores of the odour layer is not diminished. That is, in known dressings including an odour resistant layer of activated charcoal, the material is carbonised to insert carbon into the surface porosity of the layer. The layer is then adhered to an adjacent layer, thus coating some of the porous surface area with adhesive, and reducing the total surface porosity.

30 The present disclosure comprising a shaped pad and dressing border, working as more independent sub-units of the dressing than what can be seen for a standard square shape, yields better conformability with movement than standard shapes. The dressing remains conformable with the skin and comfortable to wear, allowing the patient to move whilst wearing the dressing, and without creating detrimental traction on the pen-wound skin, which could lead to slowing of wound healing.

35 Some embodiments of the present disclosure also help to reduce the unsightly appearance of a dressing during use, by using materials that impart partial masking of the dressing surface. The masking should preferably only be partial, to allow clinicians to access the information they require by observing the spread of exudate across the dressing surface.

40 This property, which is very important in helping patients live better with their treatment, had not been achieved until now for absorbent, breathable dressings. The partial masking nature of the obscuring layer enables a skilled clinician to perceive a different colour caused by exudate, blood, by-products etc. in the dressing allowing for a visual assessment and monitoring of the extent of spread across the dressing. However, since the change in colour of the dressing from its clean state to a state with exudate contained is only a slight change, the patient is unlikely to notice any aesthetic difference. Reducing or eliminating a visual indicator of wound exudate from a patient is likely to have a positive effect on their health, reducing stress for example. Also, some embodiments of the present disclosure provide a mean of relieving point pressure that may be applied to the wound area, by introducing a breathable, shear resistant layer that does not have to be in contact with the skin. This construction maximises the absorbency capacity of the

dressing by not replacing some of the absorbent area with pressure-relieving areas. Breathability of the part of the dressing in contact with the skin is also maximised, as the breathable wound contact layer, lower part of the pad, and film, are not impaired by the use of another structure in contact with the skin.

By providing an odour control layer between a foam and an absorber layer, this can help in allowing only excess fluid towards the absorber layer, whilst keeping the foam layer sufficiently moist to create a moist wound healing environment. This is because the odour layer does not draw fluid away from the foam layer at the same speed at which an absorber layer would. The transfer of fluid from the foam layer to the absorber layer is therefore slowed down (relative to having a foam layer directly adjacent an absorber layer). Therefore, only excess fluid is taken into the odour layer, thereby assisting in the foam layer maintaining some degree of moisture and not drying out.

That is, the absorption rate of the outer layer should aptly be higher than the absorption rate of the lower layer (closer to the wound).

Prior to the invention of the embodiments disclosed herein, it was generally believed that the wetting of activated charcoal would destroy the function of the material of performing odour capturing. As such, activated charcoal layers have been used as an outer layer protected from liquid by a barrier layer. However the inventors found that as long as the activated charcoal layer is not soaked in liquid the activated charcoal can perform sufficiently well as an odour removing layer.

When the layer of absorbent material folds over the edges of any other lower layers, the absorbent layer helps to prevent fluid from being squeezed from the dressing at the dressing edge region, thereby causing leakage. Various known dressings previously suffered from the risk of delamination of layers caused by fluid being squeezed towards the edge of the dressing, being driven between the layers and possibly escaping at the edge of the dressing. This may occur for example in a border region where a wound contact layer meets a cover layer, and any intermediate layers of the dressing are adjacent that border region. Aptly an absorbent layer including a superabsorber material is useful in preventing the release of any liquid, especially in the direction of the border region or edge of the dressing.

Alternative materials can be used for the absorbent layer to provide the fluid locking and leak prevention properties, for example:

absorbent or superabsorbent non-woven materials, which can be made of fibrous modified cellulose, fibrous modified chitosan, fibrous hydrophilic polyesters, fibrous cellulose, fibrous chitosan, fibrous polysaccharides

absorbent or superabsorbent foams, which can be blown hydrophilic polyurethane foam, comprising superabsorbent particles or fibres; foams of hydrophilic polyvinylacetate

absorbent or superabsorbent gels or solids, which can be hydrocolloid polymer structures, additionally comprising superabsorbent particles or fibres.

Additionally, any of the dressing embodiments disclosed herein can be used in with a source of negative pressure, such as a pump. Any of the dressing embodiments disclosed herein can also be used with a pump and a fluid or waste collection canister that can be put in fluid communication with the pump and the dressing so that the pump draws fluid or waste from the wound into the collection canister.

Additionally, in any embodiments, the pump can be a piezoelectric pump, a diaphragm pump, a voice coil actuated pump, a constant tension spring actuated pump, a manually actuated or operated pump, a battery powered pump, a DC or AC motor actuated pump, a combination of any of the foregoing, or any other suitable pump.

FIGS. 15A-B illustrate cross sections through a wound dressing 2100 according to an embodiment of the disclosure. A plan view from above the wound dressing 2100 is illustrated in FIG. 16 with the line A-A indicating the location of the cross section shown in FIGS. 15A and 15B. It will be understood that FIGS. 15A-B illustrate a generalized schematic view of an apparatus 2100. It will be understood that embodiments of the present disclosure are generally applicable to use in TNP therapy systems. Briefly, negative pressure wound therapy assists in the closure and healing of many forms of "hard to heal" wounds by reducing tissue oedema; encouraging blood flow and granular tissue formation; removing excess exudate and may reduce bacterial load (and thus infection risk). In addition, the therapy allows for less disturbance of a wound leading to more rapid healing. TNP therapy systems may also assist on the healing of surgically closed wounds by removing fluid and by helping to stabilize the tissue in the opposed position of closure. A further beneficial use of TNP therapy can be found in grafts and flaps where removal of excess fluid is important and close proximity of the graft to tissue is required in order to ensure tissue viability.

The wound dressing 2100, which can alternatively be any wound dressing embodiment disclosed herein including without limitation wound dressing 100 or have any combination of features of any number of wound dressing embodiments disclosed herein, can be located over a wound site to be treated. The dressing 2100 forms a sealed cavity over the wound site. It will be appreciated that throughout this specification reference is made to a wound. In this sense it is to be understood that the term wound is to be broadly construed and encompasses open and closed wounds in which skin is torn, cut or punctured or where trauma causes a contusion. A wound is thus broadly defined as any damaged region of tissue where fluid may or may not be produced. Examples of such wounds include, but are not limited to, incisions, lacerations, abrasions, contusions, burns, diabetic ulcers, pressure ulcers, stoma, surgical wounds, trauma and venous ulcers or the like.

In some embodiments, it may be preferable for the wound site to be filled partially or completely with a wound packing material. This wound packing material is optional, but may be desirable in certain wounds, for example deeper wounds. The wound packing material can be used in addition to the wound dressing 2100. The wound packing material generally may comprise a porous and conformable material, for example foam (including reticulated foams), and gauze. Preferably, the wound packing material is sized or shaped to fit within the wound site so as to fill any empty spaces. The wound dressing 2100 may then be placed over the wound site and wound packing material overlying the wound site. When a wound packing material is used, once the wound dressing 2100 is sealed over the wound site, TNP is transmitted from a pump through the wound dressing 2100, through the wound packing material, and to the wound site. This negative pressure draws wound exudate and other fluids or secretions away from the wound site.

It is envisaged that the negative pressure range for the apparatus embodying the present disclosure may be between about -20 mmHg and -200 mmHg (note that these pressures are relative to normal ambient atmospheric pressure thus,

-200 mmHg would be about 560 mmHg in practical terms). In one embodiment, the pressure range may be between about -40 mmHg and -150 mmHg. Alternatively a pressure range of up to -75 mmHg, up to -80 mmHg or over -80 mmHg can be used. Also in other embodiments a pressure range of below -75 mmHg could be used. Alternatively a pressure range of over -100 mmHg could be used or over -150 mmHg.

It will be appreciated that according to certain embodiments of the present disclosure, the pressure provided may be modulated over a period of time according to one or more desired and predefined pressure profiles. For example such a profile may include modulating the negative pressure between two predetermined negative pressures P1 and P2 such that pressure is held substantially constant at P1 for a pre-determined time period T1 and then adjusted by suitable means such as varying pump work or restricting fluid flow or the like, to a new predetermined pressure P2 where the pressure may be held substantially constant for a further predetermined time period T2. Two, three or four or more predetermined pressure values and respective time periods may be optionally utilized. Other embodiments may employ more complex amplitude/frequency wave forms of pressure flow profiles may also be provided e.g. sinusoidal, saw tooth, systolic-diastolic or the like.

As illustrated in FIGS. 15A-B a lower surface 2101 of the wound dressing 2100, which, again, can be any wound dressing embodiment disclosed herein including without limitation dressing embodiment 100 or have any combination of features of any number of wound dressing embodiments disclosed herein, can be provided by an optional wound contact layer 2102. The wound contact layer 2102 can be a polyurethane layer or polyethylene layer or other flexible layer which is perforated, for example via a hot pin process, laser ablation process, ultrasound process or in some other way or otherwise made permeable to liquid and gas. The wound contact layer has a lower surface 2101 and an upper surface 2103. The perforations 2104 are through holes in the wound contact layer which enables fluid to flow through the layer. The wound contact layer helps prevent tissue ingrowth into the other material of the wound dressing. The perforations are small enough to meet this requirement but still allow fluid through. For example, perforations formed as slits or holes having a size ranging from 0.025 mm to 1.2 mm are considered small enough to help prevent tissue ingrowth into the wound dressing while allowing wound exudate to flow into the dressing. The wound contact layer helps hold the whole wound dressing together and helps to create an air tight seal around the absorbent pad in order to maintain negative pressure at the wound. The wound contact layer also acts as a carrier for an optional lower and upper adhesive layer (not shown). For example, a lower pressure sensitive adhesive may be provided on the underside surface 2101 of the wound dressing whilst an upper pressure sensitive adhesive layer may be provided on the upper surface 2103 of the wound contact layer. The pressure sensitive adhesive, which may be a silicone, hot melt, hydrocolloid or acrylic based adhesive or other such adhesives, may be formed on both sides or optionally on a selected one or none of the sides of the wound contact layer. When a lower pressure sensitive adhesive layer is utilized this helps adhere the wound dressing to the skin around a wound site.

A layer 2105 of porous material can be located above the wound contact layer. This porous layer, or transmission layer, 2105 allows transmission of fluid including liquid and gas away from a wound site into upper layers of the wound

dressing. In particular, the transmission layer 2105 ensures that an open air channel can be maintained to communicate negative pressure over the wound area even when the absorbent layer has absorbed substantial amounts of exudates. The layer should remain open under the typical pressures that will be applied during negative pressure wound therapy as described above, so that the whole wound site sees an equalized negative pressure. The layer 2105 is formed of a material having a three dimensional structure. For example, a knitted or woven spacer fabric (for example Baltex 7970 weft knitted polyester) or a non-woven fabric could be used. Other materials could of course be utilized, and examples of such materials are described below with respect to FIGS. 37-41.

In some embodiments, the transmission layer comprises a 3D polyester spacer fabric layer including a top layer (that is to say, a layer distal from the wound-bed in use) which is a 84/144 textured polyester, and a bottom layer (that is to say, a layer which lies proximate to the wound bed in use) which is a 100 denier flat polyester and a third layer formed sandwiched between these two layers which is a region defined by a knitted polyester viscose, cellulose or the like monofilament fiber. Other materials and other linear mass densities of fiber could of course be used.

Whilst reference is made throughout this disclosure to a monofilament fiber it will be appreciated that a multistrand alternative could of course be utilized.

The top spacer fabric thus has more filaments in a yarn used to form it than the number of filaments making up the yarn used to form the bottom spacer fabric layer.

This differential between filament counts in the spaced apart layers helps control moisture flow across the transmission layer. Particularly, by having a filament count greater in the top layer, that is to say, the top layer is made from a yarn having more filaments than the yarn used in the bottom layer, liquid tends to be wicked along the top layer more than the bottom layer. In use, this differential tends to draw liquid away from the wound bed and into a central region of the dressing where the absorbent layer helps lock the liquid away or itself wicks the liquid onwards towards the cover layer where it can be transpired.

Preferably, to improve the liquid flow across the transmission layer (that is to say perpendicular to the channel region formed between the top and bottom spacer layers, the 3D fabric is treated with a dry cleaning agent (such as, but not limited to, Perchloro Ethylene) to help remove any manufacturing products such as mineral oils, fats and/or waxes used previously which might interfere with the hydrophilic capabilities of the transmission layer. In some embodiments, an additional manufacturing step can subsequently be carried in which the 3D spacer fabric is washed in a hydrophilic agent (such as, but not limited to, Feran Ice 30 g/l available from the Rudolph Group). This process step helps ensure that the surface tension on the materials is so low that liquid such as water can enter the fabric as soon as it contacts the 3D knit fabric. This also aids in controlling the flow of the liquid insult component of any exudates.

A layer 2110 of absorbent material is provided above the transmission layer 2105. The absorbent material which may be a foam or non-woven natural or synthetic material and which may optionally include or be super-absorbent material forms a reservoir for fluid, particularly liquid, removed from the wound site and draws those fluids towards a cover layer 2140. With reference to FIGS. 15A and 15B, a masking or obscuring layer 2107 can be positioned beneath the cover layer 2140. In some embodiments, the masking layer 2107 can have any of the same features, materials, or other details

of any of the other embodiments of the masking layers disclosed herein, including but not limited to having any viewing windows or holes. Additionally, the masking layer **2107** can be positioned adjacent to the cover layer, or can be positioned adjacent to any other dressing layer desired. In some embodiments, the masking layer **2107** can be adhered to or integrally formed with the cover layer. In some embodiments the masking layer **2107** may optionally contain a hole (not shown) directly adjacent to the port **2150** to improve air flow through the layer.

The material of the absorbent layer also prevents liquid collected in the wound dressing from flowing in a sloshing manner. The absorbent layer **2110** also helps distribute fluid throughout the layer via a wicking action so that fluid is drawn from the wound site and stored throughout the absorbent layer. This helps prevent agglomeration in areas of the absorbent layer. The capacity of the absorbent material must be sufficient to manage the exudates flow rate of a wound when negative pressure is applied. Since in use the absorbent layer experiences negative pressures the material of the absorbent layer is chosen to absorb liquid under such circumstances. A number of materials exist that are able to absorb liquid when under negative pressure, for example superabsorber material. The absorbent layer **2110** may typically be manufactured from ALLEVYN™ foam, Freudenberg 114-224-4 and/or Chem-Posite™ 11C-450.

In some embodiments, the absorbent layer is a layer of non-woven cellulose fibers having super-absorbent material in the form of dry particles dispersed throughout. Use of the cellulose fibers introduces fast wicking elements which help quickly and evenly distribute liquid taken up by the dressing. The juxtaposition of multiple strand-like fibers leads to strong capillary action in the fibrous pad which helps distribute liquid. In this way, the super-absorbent material is efficiently supplied with liquid. Also, all regions of the absorbent layer are provided with liquid.

The wicking action also assists in bringing liquid into contact with the upper cover layer to aid increase transpiration rates of the dressing.

The wicking action also assists in delivering liquid downwards towards the wound bed when exudation slows or halts. This delivery process helps maintain the transmission layer and lower wound bed region in a moist state which helps prevent crusting within the dressing (which could lead to blockage) and helps maintain an environment optimized for wound healing.

In some embodiments, the absorbent layer may be an air-laid material. Heat fusible fibers may optionally be used to assist in holding the structure of the pad together. It will be appreciated that rather than using super-absorbing particles or in addition to such use, super-absorbing fibers may be utilized according to certain embodiments of the present disclosure. An example of a suitable material is the Product Chem-Posite™ 11 C available from Emerging Technologies Inc (ETi) in the USA.

Optionally, according to some embodiments of the present disclosure, the absorbent layer may include synthetic stable fibers and/or bi-component stable fibers and/or natural stable fibers and/or super-absorbent fibers. Fibers in the absorbent layer may be secured together by latex bonding or thermal bonding or hydrogen bonding or a combination of any bonding technique or other securing mechanism. In some embodiments, the absorbent layer is formed by fibers which operate to lock super-absorbent particles within the absorbent layer. This helps ensure that super-absorbent particles do not move external to the absorbent layer and towards an underlying wound bed. This is particularly

helpful because when negative pressure is applied there is a tendency for the absorbent pad to collapse downwards and this action would push super-absorbent particle matter into a direction towards the wound bed if they were not locked away by the fibrous structure of the absorbent layer.

The absorbent layer may comprise a layer of multiple fibers. Preferably, the fibers are strand-like and made from cellulose, polyester, viscose or the like. Preferably, dry absorbent particles are distributed throughout the absorbent layer ready for use. In some embodiments, the absorbent layer comprises a pad of cellulose fibers and a plurality of super absorbent particles. In additional embodiments, the absorbent layer is a non-woven layer of randomly orientated cellulose fibers.

Super-absorber particles/fibers may be, for example, sodium polyacrylate or carbomethoxycellulose materials or the like or any material capable of absorbing many times its own weight in liquid. In some embodiments, the material can absorb more than five times its own weight of 0.9% W/W saline, etc. In some embodiments, the material can absorb more than 15 times its own weight of 0.9% W/W saline, etc. In some embodiments, the material is capable of absorbing more than 20 times its own weight of 0.9% W/W saline, etc. Preferably, the material is capable of absorbing more than 30 times its own weight of 0.9% W/W saline, etc.

Preferably, the particles of superabsorber are very hydrophilic and grab the fluid as it enters the dressing, swelling up on contact. An equilibrium is set up within the dressing core whereby moisture passes from the superabsorber into the dryer surrounding area and as it hits the top film the film switches and the fluid vapor starts to be transpired. A moisture gradient is established within the dressing to continually remove fluid from the wound bed and ensure the dressing does not become heavy with exudate.

Preferably the absorbent layer includes at least one through hole located so as to underly the suction port. As illustrated in FIGS. **15A-B** a single through hole can be used to produce an opening underlying the port **2150**. It will be appreciated that multiple openings could alternatively be utilized. Additionally should more than one port be utilized according to certain embodiments of the present disclosure one or multiple openings may be made in the super-absorbent layer in registration with each respective port. Although not essential to certain embodiments of the present disclosure the use of through holes in the super-absorbent layer provide a fluid flow pathway which is particularly unhindered and this is useful in certain circumstances.

Where an opening is provided in the absorbent layer the thickness of the layer itself will act as a stand-off separating any overlying layer from the upper surface (that is to say the surface facing away from a wound in use) of the transmission layer **2105**. An advantage of this is that the filter of the port is thus decoupled from the material of the transmission layer. This helps reduce the likelihood that the filter will be wetted out and thus will occlude and block further operation.

Use of one or more through holes in the absorption layer also has the advantage that during use if the absorbent layer contains a gel forming material, such as superabsorber, that material as it expands to absorb liquid, does not form a barrier through which further liquid movement and fluid movement in general cannot pass. In this way each opening in the absorbent layer provides a fluid pathway between the transmission layer directly to the wound facing surface of the filter and then onwards into the interior of the port.

A gas impermeable, but moisture vapor permeable, cover layer **2140** can extend across the width of the wound dressing, which can be any wound dressing embodiment

disclosed herein including without limitation dressing embodiment **100** or have any combination of features of any number of wound dressing embodiments disclosed herein. The cover layer, which may for example be a polyurethane film (for example, Elastollan SP9109) having a pressure sensitive adhesive on one side, is impermeable to gas and this layer thus operates to cover the wound and to seal a wound cavity over which the wound dressing is placed. In this way an effective chamber is made between the cover layer and a wound site where a negative pressure can be established. The cover layer **2140** is sealed to the wound contact layer **2102** in a border region **2200** around the circumference of the dressing, ensuring that no air is drawn in through the border area, for example via adhesive or welding techniques. The cover layer **140** protects the wound from external bacterial contamination (bacterial barrier) and allows liquid from wound exudates to be transferred through the layer and evaporated from the film outer surface. The cover layer **2140** typically comprises two layers; a polyurethane film and an adhesive pattern spread onto the film. The polyurethane film is moisture vapor permeable and may be manufactured from a material that has an increased water transmission rate when wet.

The absorbent layer **2110** may be of a greater area than the transmission layer **2105**, such that the absorbent layer overlaps the edges of the transmission layer **2105**, thereby ensuring that the transmission layer does not contact the cover layer **2140**. This provides an outer channel **2115** of the absorbent layer **2110** that is in direct contact with the wound contact layer **2102**, which aids more rapid absorption of exudates to the absorbent layer. Furthermore, this outer channel **2115** ensures that no liquid is able to pool around the circumference of the wound cavity, which may otherwise seep through the seal around the perimeter of the dressing leading to the formation of leaks.

In order to ensure that the air channel remains open when a vacuum is applied to the wound cavity, the transmission layer **2105** must be sufficiently strong and non-compliant to resist the force due to the pressure differential. However, if this layer comes into contact with the relatively delicate cover layer **2140**, it can cause the formation of pin-hole openings in the cover layer **2140** which allow air to leak into the wound cavity. This may be a particular problem when a switchable type polyurethane film is used that becomes weaker when wet. The absorbent layer **2110** is generally formed of a relatively soft, non-abrasive material compared to the material of the transmission layer **2105** and therefore does not cause the formation of pin-hole openings in the cover layer. Thus by providing an absorbent layer **2110** that is of greater area than the transmission layer **2105** and that overlaps the edges of the transmission layer **2105**, contact between the transmission layer and the cover layer is prevented, avoiding the formation of pin-hole openings in the cover layer **2140**.

The absorbent layer **2110** is positioned in fluid contact with the cover layer **2140**. As the absorbent layer absorbs wound exudate, the exudate is drawn towards the cover layer **2140**, bringing the water component of the exudate into contact with the moisture vapor permeable cover layer. This water component is drawn into the cover layer itself and then evaporates from the top surface of the dressing. In this way, the water content of the wound exudate can be transpired from the dressing, reducing the volume of the remaining wound exudate that is to be absorbed by the absorbent layer **2110**, and increasing the time before the dressing becomes full and must be changed. This process of transpiration occurs even when negative pressure has been applied to the

wound cavity, and it has been found that the pressure difference across the cover layer when a negative pressure is applied to the wound cavity has negligible impact on the moisture vapor transmission rate across the cover layer.

An orifice **2145** is provided in the cover film **2140** to allow a negative pressure to be applied to the dressing **2100**. A suction port **2150** is sealed to the top of the cover film **2140** over the orifice **2145**, and communicates negative pressure through the orifice **2145**. A length of tubing **2220** may be coupled at a first end to the suction port **2150** and at a second end to a pump unit (not shown) to allow fluids to be pumped out of the dressing. The port may be adhered and sealed to the cover film **2140** using an adhesive such as an acrylic, cyanoacrylate, epoxy, UV curable or hot melt adhesive. The port **2150** is formed from a soft polymer, for example a polyethylene, a polyvinyl chloride, a silicone or polyurethane having a hardness of 30 to 90 on the Shore A scale.

An aperture or through-hole **2146** is provided in the absorbent layer **2110** beneath the orifice **2145** such that the orifice is connected directly to the transmission layer **2105**. This allows the negative pressure applied to the port **2150** to be communicated to the transmission layer **2105** without passing through the absorbent layer **2110**. This ensures that the negative pressure applied to the wound site is not inhibited by the absorbent layer as it absorbs wound exudates. In other embodiments, no aperture may be provided in the absorbent layer **2110**, or alternatively a plurality of apertures underlying the orifice **2145** may be provided.

As shown in FIG. 15A, one embodiment of the wound dressing **2100** comprises an aperture **2146** in the absorbent layer **2100** situated underneath the port **2150**. In use, for example when negative pressure is applied to the dressing **2100**, a wound facing portion of the port **150** may thus come into contact with the transmission layer **2105**, which can thus aid in transmitting negative pressure to the wound site even when the absorbent layer **2110** is filled with wound fluids. Some embodiments may have the cover layer **2140** be at least partly adhered to the transmission layer **2105**. In some embodiments, the aperture **2146** is at least 1-2 mm larger than the diameter of the wound facing portion of the port **2150**, or the orifice **2145**.

A filter element **2130** that is impermeable to liquids, but permeable to gases is provided to act as a liquid barrier, and to ensure that no liquids are able to escape from the wound dressing. The filter element may also function as a bacterial barrier. Typically the pore size is 0.2 μm . Suitable materials for the filter material of the filter element **2130** include 0.2 micron GoreTM expanded PTFE from the MMT range, PALL VersaporeTM 200R, and DonaldsonTM TX6628. Larger pore sizes can also be used but these may require a secondary filter layer to ensure full bioburden containment. As wound fluid contains lipids it is preferable, though not essential, to use an oleophobic filter membrane for example 1.0 micron MMT-332 prior to 0.2 micron MMT-323. This prevents the lipids from blocking the hydrophobic filter. The filter element can be attached or sealed to the port and/or the cover film **2140** over the orifice **2145**. For example, the filter element **2130** may be molded into the port **2150**, or may be adhered to both the top of the cover layer **2140** and bottom of the port **2150** using an adhesive such as, but not limited to, a UV cured adhesive.

It will be understood that other types of material could be used for the filter element **2130**. More generally a microporous membrane can be used which is a thin, flat sheet of polymeric material, this contains billions of microscopic pores. Depending upon the membrane chosen these pores

can range in size from 0.01 to more than 10 micrometers. Microporous membranes are available in both hydrophilic (water filtering) and hydrophobic (water repellent) forms. In some embodiments of the disclosure, filter element **2130** comprises a support layer and an acrylic co-polymer membrane formed on the support layer. Preferably the wound dressing **2100** according to certain embodiments of the present disclosure uses microporous hydrophobic membranes (MHMs). Numerous polymers may be employed to form MHMs. For example, PTFE, polypropylene, PVDF and acrylic copolymer. All of these optional polymers can be treated in order to obtain specific surface characteristics that can be both hydrophobic and oleophobic. As such these will repel liquids with low surface tensions such as multi-vitamin infusions, lipids, surfactants, oils and organic solvents.

MHMs block liquids whilst allowing air to flow through the membranes. They are also highly efficient air filters eliminating potentially infectious aerosols and particles. A single piece of MHM is well known as an option to replace mechanical valves or vents. Incorporation of MHMs can thus reduce product assembly costs improving profits and costs/benefit ratio to a patient.

The filter element **2130** may also include an odor absorbent material, for example activated charcoal, carbon fiber cloth or Vitec Carbotec-RT Q2003073 foam, or the like. For example, an odor absorbent material may form a layer of the filter element **2130** or may be sandwiched between microporous hydrophobic membranes within the filter element.

The filter element **2130** thus enables gas to be exhausted through the orifice **2145**. Liquid, particulates and pathogens however are contained in the dressing.

In FIG. **15B**, an embodiment of the wound dressing **2100** is illustrated which comprises spacer elements **2152**, **2153** in conjunction with the port **2150** and the filter **2130**. With the addition of such spacer elements **2152**, **2153**, the port **2150** and filter **2130** may be supported out of direct contact with the absorbent layer **2110** and/or the transmission layer **2105**. The absorbent layer **2110** may also act as an additional spacer element to keep the filter **2130** from contacting the transmission layer **2105**. Accordingly, with such a configuration contact of the filter **2130** with the transmission layer **2105** and wound fluids during use may thus be minimized. As contrasted with the embodiment illustrated in FIG. **15A**, the aperture **2146** through the absorbent layer **2110** may not necessarily need to be as large or larger than the port **2150**, and would thus only need to be large enough such that an air path can be maintained from the port to the transmission layer **2105** when the absorbent layer **2110** is saturated with wound fluids.

In particular for embodiments with a single port **2150** and through hole, it may be preferable for the port **2150** and through hole to be located in an off-center position as illustrated in FIGS. **15A-B** and in FIG. **16**. Such a location may permit the dressing **2100** to be positioned onto a patient such that the port **2150** is raised in relation to the remainder of the dressing **2100**. So positioned, the port **2150** and the filter **2130** may be less likely to come into contact with wound fluids that could prematurely occlude the filter **2130** so as to impair the transmission of negative pressure to the wound site.

FIG. **25** shows a plan view of a suction port **2150** according to some embodiments of the disclosure. The suction port comprises a sealing surface **2152** for sealing the port to a wound dressing, a connector portion **2154** for connecting the suction port **2150** to a source of negative pressure, and a hemispherical body portion **2156** disposed between the sealing surface **2152** and the connector portion

2154. Sealing surface **2152** comprises a flange that provides a substantially flat area to provide a good seal when the port **2150** is sealed to the cover layer **2140**. Connector portion **2154** is arranged to be coupled to the external source of negative pressure via a length of tube **2220**.

According to some embodiments, the filter element **2130** forms part of the bacterial barrier over the wound site, and therefore it is important that a good seal is formed and maintained around the filter element. However, it has been determined that a seal formed by adhering the filter element **2130** to the cover layer **2140** is not sufficiently reliable. This is a particular problem when a moisture vapor permeable cover layer is used, as the water vapor transpiring from the cover layer **2140** can affect the adhesive, leading to breach of the seal between the filter element and the cover layer. Thus, according to some embodiments of the disclosure an alternative arrangement for sealing the filter element **2130** to stop liquid from entering the connector portion **2154** is employed.

FIG. **26** illustrates a cross section through the suction port **2150** of FIG. **25** according to some embodiments of the disclosure, the line A-A in FIG. **25** indicating the location of the cross section. In the suction port of FIG. **26**, the suction port **2150** further comprises filter element **2130** arranged within the body portion **2156** of the suction port **2150**. A seal between the suction port **2150** and the filter element **2130** is achieved by molding the filter element within the body portion of the suction port **2150**.

FIG. **27** illustrates a cross section through the suction port **2150** of FIG. **25** according to some embodiments of the disclosure that can be used with any dressing embodiment disclosed herein. In the suction port of FIG. **27**, the filter element **2130** is sealed to the sealing surface **2152** of the suction port **2150**. The filter element may be 2D sealed to the sealing surface using an adhesive or by welding the filter element to the sealing surface.

By providing the filter element **2130** as part of the suction port **2150**, as illustrated in FIGS. **26** and **27**, the problems associated with adhering the filter element to the cover layer **2140** are avoided allowing a reliable seal to be provided. Furthermore, providing a sub-assembly having the filter element **2130** included as part of the suction port **2150** allows for simpler and more efficient manufacture of the wound dressing **2100**.

While the suction port **2150** has been described in the context of the wound dressing **2100** of FIG. **15**, it will be understood that the embodiments of FIGS. **26** and **27** are applicable to any wound dressing for applying a negative pressure to a wound disclosed herein or otherwise, wherein wound exudate drawn from the wound is retained within the dressing. According to some embodiments of the disclosure, the suction port **2150** may be manufactured from a transparent material in order to allow a visual check to be made by a user for the ingress of wound exudate into the suction port **2150**.

The wound dressing **2100** and its methods of manufacture and use as described herein may also incorporate features, configurations and materials described in the following patents and patent applications that are all incorporated by reference in their entireties herein: U.S. Pat. Nos. 7,524,315, 7,708,724, and 7,909,805; U.S. Patent Application Publication Nos. 2005/0261642, 2007/0167926, 2009/0012483, 2009/0254054, 2010/0160879, 2010/0160880, 2010/0174251, 2010/0274207, 2010/0298793, 2011/0009838, 2011/0028918, 2011/0054421, and 2011/0054423; as well as U.S. application Ser. No. 12/941,390, filed Nov. 8, 2010, Ser. No. 29/389,782, filed Apr. 15, 2011, and Ser. No.

29/389,783, filed Apr. 15, 2011. From these incorporated by reference patents and patent applications, features, configurations, materials and methods of manufacture or use for similar components to those described in the present disclosure may be substituted, added or implemented into embodiments of the present application.

In operation the wound dressing **2100** is sealed over a wound site forming a wound cavity. A pump unit (illustrated in FIG. **42** and described in further detail below) applies a negative pressure at a connection portion **2154** of the port **2150** which is communicated through the orifice **2145** to the transmission layer **2105**. Fluid is drawn towards the orifice through the wound dressing from a wound site below the wound contact layer **2102**. The fluid moves towards the orifice through the transmission layer **2105**. As the fluid is drawn through the transmission layer **2105** wound exudate is absorbed into the absorbent layer **2110**.

Turning to FIG. **16** which illustrates a wound dressing **2100** in accordance with an embodiment of the present disclosure one can see the upper surface of the cover layer **2140** which extends outwardly away from a centre of the dressing into a border region **2200** surrounding a central raised region **2201** overlying the transmission layer **2105** and the absorbent layer **2110**. As indicated in FIG. **16** the general shape of the wound dressing is rectangular with rounded corner regions **2202**. It will be appreciated that wound dressings according to other embodiments of the present disclosure can be shaped differently such as square, circular or elliptical dressings, or the like.

The wound dressing **2100** may be sized as necessary for the size and type of wound it will be used in. In some embodiments, the wound dressing **2100** may measure between 20 and 40 cm on its long axis, and between 10 to 25 cm on its short axis. For example, dressings may be provided in sizes of 10×20 cm, 10×30 cm, 10×40 cm, 15×20 cm, and 15×30 cm. In some embodiments, the wound dressing **2100** may be a square-shaped dressing with sides measuring between 15 and 25 cm (e.g., 15×15 cm, 20×20 cm and 25×25 cm). The absorbent layer **2110** may have a smaller area than the overall dressing, and in some embodiments may have a length and width that are both about 3 to 10 cm shorter, more preferably about 5 cm shorter, than that of the overall dressing **2100**. In some rectangular-shape embodiments, the absorbent layer **2110** may measure between 10 and 35 cm on its long axis, and between 5 and 10 cm on its short axis. For example, absorbent layers may be provided in sizes of 5.6×15 cm or 5×10 cm (for 10×20 cm dressings), 5.6×25 cm or 5×20 cm (for 10×30 cm dressings), 5.6×35 cm or 5×30 cm (for 10×40 cm dressings), 10×15 cm (for 15×20 cm dressings), and 10×25 cm (for 15×30 cm dressings). In some square-shape embodiments, the absorbent layer **2110** may have sides that are between 10 and 20 cm in length (e.g., 10×10 cm for a 15×15 cm dressing, 15×15 cm for a 20×20 cm dressing, or 20×20 cm for a 25×25 cm dressing). The transmission layer **2105** is preferably smaller than the absorbent layer, and in some embodiments may have a length and width that are both about 0.5 to 2 cm shorter, more preferably about 1 cm shorter, than that of the absorbent layer. In some rectangular-shape embodiments, the transmission layer may measure between 9 and 34 cm on its long axis and between 3 and 5 cm on its short axis. For example, transmission layers may be provided in sizes of 4.6×14 cm or 4×9 cm (for 10×20 cm dressings), 4.6×24 cm or 4×19 cm (for 10×30 cm dressings), 4.6×34 cm or 4×29 cm (for 10×40 cm dressings), 9×14 cm (for 15×20 cm dressings), and 9×24 cm (for 15×30 cm dressings). In some square-shape embodiments, the transmission layer may have

sides that are between 9 and 19 cm in length (e.g., 9×9 cm for a 15×15 cm dressing, 14×14 cm for a 20×20 cm dressing, or 19×19 cm for a 25×25 cm dressing).

It will be understood that according to embodiments of the present disclosure the wound contact layer is optional. This layer is, if used, porous to water and faces an underlying wound site. A transmission layer **2105** such as an open celled foam, or a knitted or woven spacer fabric is used to distribute gas and fluid removal such that all areas of a wound are subjected to equal pressure. The cover layer together with the filter layer forms a substantially liquid tight seal over the wound. Thus when a negative pressure is applied to the port **2150** the negative pressure is communicated to the wound cavity below the cover layer. This negative pressure is thus experienced at the target wound site. Fluid including, air and wound exudate is drawn through the wound contact layer and transmission layer **2105**. The wound exudate drawn through the lower layers of the wound dressing is dissipated and absorbed into the absorbent layer **2110** where it is collected and stored. Air and moisture vapor is drawn upwards through the wound dressing through the filter layer and out of the dressing through the suction port. A portion of the water content of the wound exudate is drawn through the absorbent layer and into the cover layer **2140** and then evaporates from the surface of the dressing.

As discussed above, when a negative pressure is applied to a wound dressing sealed over a wound site, in some dressing embodiments disclosed herein, fluids including wound exudate are drawn from the wound site and through the transmission layer **2105** toward the orifice **2145**. Wound exudate is then drawn into the absorbent layer **2110** where it is absorbed. However, some wound exudate may not be absorbed and may move to the orifice **2145**. Filter element **2130** provides a barrier that stops any liquid in the wound exudate from entering the connection portion **2154** of the suction port **2150**. Therefore, unabsorbed wound exudate may collect underneath the filter element **2130**. If sufficient wound exudate collects at the filter element, a layer of liquid will form across the surface of filter element **2130** and the filter element will become blocked as the liquid cannot pass through the filter element **2130** and gases will be stopped from reaching the filter element by the liquid layer. Once the filter element becomes blocked, negative pressure can no longer be communicated to the wound site, and the wound dressing must be changed for a fresh dressing, even though the total capacity of the absorbent layer has not been reached.

In a preferred embodiment, the port **2150**, along with any aperture **2146** in the absorbing layer **2110** situated below it, generally aligns with the mid-longitudinal axis A-A illustrated in FIG. **16**. Preferably, the port **2150** and any such aperture **2146** are situated closer to one end of the dressing, contrasted with a central position. In some embodiments, the port may be located at a corner of the dressing **2100**, which again can be any dressing embodiment disclosed herein including without limitation dressing embodiment **100**. For example, in some rectangular embodiments, the port **2150** may be located between 4 and 6 cm from the edge of the dressing, with the aperture **146** located 2 to 3 cm from the edge of the absorbent layer. In some square embodiments, the port **2150** may be located between 5 to 8 cm from the corner of the dressing, with the aperture **2146** located 3 to 5 cm from the corner of the absorbent layer.

Certain orientations of the wound dressing may increase the likelihood of the filter element **130** becoming blocked in this way, as the movement of the wound exudate through the

transmission layer may be aided by the effect of gravity. Thus, if due to the orientation of the wound site and wound dressing, gravity acts to increase the rate at which wound exudate is drawn towards the orifice **2145**, the filter may become blocked with wound exudate more quickly. Thus, 5 the wound dressing would have to be changed more frequently and before the absorbent capacity of the absorbent layer **2110** has been reached.

In order to avoid the premature blocking of the wound dressing **2100** by wound exudate drawn towards the orifice **2145** some embodiments of the disclosure include at least one element configured to reduce the rate at which wound exudate moves towards the orifice **2145**. The at least one element may increase the amount of exudate that is absorbed into the absorbent layer before reaching the orifice. **2145** 10 and/or may force the wound exudate to follow a longer path through the dressing before reaching the orifice **2145**, thereby increasing the time before the wound dressing becomes blocked.

FIG. **17** shows a plan view of a wound dressing including baffle elements that reduce the rate at which wound exudate moves towards the orifice according to one embodiment of the disclosure. The wound dressing illustrated in FIG. **17** is similar to that shown in FIGS. **15** and **16**, but includes a number of baffle elements **2310** disposed across the central raised region **2201**. The baffle elements **2310** form barriers in the central region of the dressing, which arrest the movement of wound exudate towards the orifice. 20

Embodiments of baffle elements that may be used in the wound dressing described herein are preferably at (east partly flexible, so as to permit the wound dressing to flex and conform with the skin of the patient surrounding the wound site. When so present in the wound dressing, the baffle elements are preferably constructed so as to at least partially prevent liquid from flowing directly to the wound dressing port or orifice and its associated filter, if so provided. The baffle elements thus increase the distance that liquids may require to reach the port, which may help in absorbing these fluids into the absorbent or superabsorbent material of the wound dressing. 25

According to some embodiments of the disclosure, the baffle element may comprise a sealing region in which the absorbent layer **2110** and transmission layer **2105** are absent and cover layer **2140** is sealed to the wound contact layer **2101**. Thus, the baffle element presents a barrier to the motion of the wound exudate, which must therefore follow a path that avoids the baffle element. Thus the time taken for the wound exudate to reach the orifice is increased. 30

In some embodiments, the baffle elements may be an insert of a substantially non-porous material, for example a closed-cell polyethylene foam, placed inside the dressing. In some cases, it may be preferable to place such an inserted baffle element in a sealing region where one or more of the absorbent layer **2110** and/or transmission layer **2105** are absent. A sealant, for example a viscous curing sealant such as a silicone sealant, could be placed or injected as a thin strip so as to form a baffle element that is substantially liquid impermeable. Such a baffle element could be placed or injected into a region of the transmission layer **2105** and/or absorbent layer **2110**, or also a sealing region where the absorbent layer **2110** and/or transmission layer **2105** are absent. 35

FIG. **20** illustrates a wound dressing, which can be any embodiment of a wound dressing disclosed herein, including a baffle element according to a further embodiment of the disclosure. A single baffle element **2610** provides a cup shaped barrier between the bulk of the absorbent layer **2110** 40

and the orifice **2145**. Thus wound exudate that is initially drawn from the wound site within the region defined by the baffle element **2610**, must follow a path around the outside of the cup shaped barrier to reach the orifice **2145**. As will be recognized, the baffle element **2610** reduces the effect of gravity on reducing the time taken for the wound exudate to move to the orifice **2145**, as for most orientations of the wound dressing at least a part of the path taken by the wound exudate will be against the force of gravity. 45

The embodiments of FIGS. **17** and **20** have been described with respect to a wound dressing having a structure as shown in FIG. **15**. However, it will be understood that the baffle elements could equally be applied to a wound dressing in which the transmission layer **2105** was absent. 50

FIG. **18** shows a plan view of a wound dressing including the at least one element according to one embodiment of the disclosure in which a number of baffle elements **2410** are provided that extend across the width of the central region **2201** of the wound dressing, with further baffle elements **2412** formed in a semi-circular path around the orifice **2145**. 55

FIG. **19** illustrates the configuration of baffle elements **2410** according to some embodiments of the disclosure. The baffle element comprises a channel of absorbent material **2510** underlying the transmission layer **2105**. A channel in the absorbent layer **2110** is located over the baffle element **2410** so that the transmission layer is in contact with the cover layer **2140** in the region of the baffle element **2410**. Thus, wound exudate that is moving along a lower surface of the transmission layer **2105**, and has therefore not been drawn into absorbent layer **2110**, will come into contact with and be absorbed by the channel of absorbent material **2510**. 60

Alternatively, or additionally, baffle elements may comprise one or more channels provided in the surface of the transmission layer **2105** underlying and abutting the absorbent layer **2110**. In use, when negative pressure is applied to the wound dressing, the absorbent layer **2110** will be drawn into the channel. The channel in the transmission layer may have a depth substantially equal to the depth of the transmission layer, or may have a depth less than the depth of the transmission layer. The dimensions of the channel may be chosen to ensure that the channel is filled by the absorbent layer **2110** when negative pressure is applied to the wound dressing. According to some embodiments, the channel in the transmission layer comprises a channel of absorbent material in the transmission layer **2105**. 65

The baffle elements may be formed into a range of shapes and patterns, for example FIGS. **28A** to **28L** illustrate wound dressings having a number of different exemplifying configurations of baffle elements. FIG. **28A** illustrates a linear baffle element in a vertical configuration aligned in the direction of the port or orifice. FIG. **28B** illustrates an X-shaped baffle element. FIGS. **28C-E** illustrate embodiments of wound dressings with multiple baffle elements, aligned in a generally diagonal, horizontal, or vertical manner. 70

FIG. **28F** illustrates baffle elements arranged in a six-armed starburst configuration, with a center portion left open. FIG. **28G** illustrates a W-shaped baffle element on the wound dressing in a position distal to the port or orifice. In FIG. **28H**, an 3-by-3 array of X-shaped baffle elements is provided on the wound dressing, although it will be understood that more or less X-shaped baffle elements may be used. FIG. **28I** shows an embodiment with a plurality of rectangular baffle elements, and wherein one or more baffle elements are located underneath the port in the wound dressing. FIGS. **28J-K** illustrate wound dressing embodiments with longer diagonal and horizontal baffle elements. 75

In FIG. 28L, rectangular baffle elements are present on this embodiment of a wound dressing, wherein the baffle elements are of different sizes.

According to some embodiments of the disclosure, the at least one element comprises an array of vias, or troughs, in the transmission layer 2105. FIG. 29 illustrates a transmission layer 2105 that is perforated with diamond shaped vias 2210. The vias 2210 are arranged such that no linear pathway exists through the pattern of vias that does not intersect with one or more of the vias 2210.

When negative pressure is applied to the wound dressing, the absorbent layer 2110 is drawn into the vias 2210, increasing the area of the absorbent layer that comes into contact with wound exudate being drawn through the transmission layer 2105. Alternatively, the vias 2210 may be filled with further absorbent material for absorbing wound exudate being drawn through the transmission layer 2105. The vias may extend through the depth of the transmission layer 2105, or may extend through only part of the transmission layer.

Wound exudate moving through the transmission layer 2105 under the influence of gravity will fall through the transmission layer in a substantially linear manner. Any such linear pathways will, at some point, intersect with one of the vias 2210, and thus the exudate will be brought into contact with absorbent material within the vias 2210. Wound exudate coming into contact with absorbent material will be absorbed, stopping the flow of the wound exudate through the transmission layer 2105, and reducing the amount of unabsorbed wound exudate that may otherwise pool around the orifice. It will be appreciated that the vias are not limited to diamond shapes, and that any pattern of vias may be used. Preferably, the vias will be arranged to ensure that all linear paths through the transmission layer 2105 intersect with at least one via. The pattern of vias may be chosen to minimize the distance that wound exudate is able to travel through the transmission layer before encountering a via and being absorbed.

FIG. 21 illustrates a wound dressing in accordance with some embodiments of the disclosure in which the at least one element comprises an air channel 2710 connecting the central region 2201 of the wound dressing to the orifice 2145. In the embodiment of FIG. 21, the air channel 2710 extends from an edge region of the transmission layer 2105 and connects the transmission layer to the orifice 2145.

In use, wound exudate is drawn towards the orifice 2145 by the application of negative pressure at the suction port 2150. However, the air channel 2710 present a relatively long serpentine path to be followed by the wound exudate before it reaches the orifice 2145. This long path increases the time that negative pressure can be applied to the dressing before wound exudate traverses the distance between the transmission layer and the orifice and blocks the filter element 2130, thereby increasing the time the dressing can be in use before it must be replaced.

FIG. 22 illustrates a wound dressing in accordance with one embodiment of the disclosure in which the at least one element comprises air channels 2810 and 2812 connecting the central region 2201 of the wound dressing to the orifice 2145. Channels 2810 and 2812 are coupled to the transmission layer at substantially opposite corners of the central region 2201.

The wound dressing shown in FIG. 22 reduces the effect of gravity on the time taken for the orifice to become blocked. If the wound dressing is in an orientation in which wound exudate moves under the influence of gravity towards the edge region of the transmission layer connected

to air channel 2810, the effect of gravity will be to move wound exudate away from the edge region of the transmission layer coupled to air channel 2812, and vice versa. Thus, the embodiment of FIG. 22 provides alternative air channels for coupling the negative pressure to the transmission layer such that, should one air channel become blocked a remaining air channel should remain open and able to communicate the negative pressure to the transmission layer 2105, thereby increasing the time before negative pressure can no longer be applied to the wound dressing and the dressing must be changed.

Further embodiments of the disclosure may comprise greater numbers of air channels connecting the transmission layer 2105 to the orifice.

According to some embodiments of the disclosure, two or more orifices may be provided in the cover layer 2140 for applying the negative pressure to the wound dressing. The two or more orifices can be distributed across the cover layer 2140 such that if one orifice becomes blocked by wound exudate due to the wound dressing being in a particular orientation, at least one remaining orifice would be expected to remain unblocked. Each orifice is in fluid communication with a wound chamber defined by the wound dressing, and is therefore able to communicate the negative pressure to the wound site.

FIG. 23 illustrates a wound dressing in accordance with a further embodiment of the disclosure. The wound dressing of FIG. 23 is similar to that of FIGS. 15A-B but includes two orifices 2145 and 2845 provided in the cover layer 2140. A fluid communication passage connects the two orifices such that a negative pressure applied to one of the orifices is communicated to the remaining orifice via the fluid communication passage. The orifices 2145, 2845 are located in opposite corner regions of the cover layer 2140. The fluid communication passage is formed using a flexible molding 2910 on the upper surface of the cover layer 2140. It will be appreciated that the flexible molding may be formed from other suitable means for example a strip of transmission or open porous foam layer placed on the cover layer 2140 between the orifices 2145 and 2845 and a further film welded or adhered over the strip thus sealing it to the cover layer and forming a passageway through the foam. A conduit may then be attached in a known manner to the sealing film for application of negative pressure.

In use, the wound dressing having two orifices is sealed over a wound site to form a wound cavity and an external source of negative pressure is applied to one of the orifices 2145, 2845, and the negative pressure will be communicated to the remaining orifice via the fluid communication passage. Thus, the negative pressure is communicated via the two orifices 2145, 845 to the transmission layer 2105, and thereby to the wound site. If one of the orifices 2145, 2845 becomes blocked due to wound exudate collecting at the orifice under the influence of gravity, the remaining orifice should remain clear, allowing negative pressure to continue to be communicated to the wound site. According to some embodiments, the transmission layer 2105 may be omitted, and the two orifices will communicate the negative pressure to the wound site via the absorbent layer 2110.

FIG. 24 illustrates a side view of the fluid communication passage of the embodiment of FIG. 23. Molding 2910 is sealed to the top surface of the cover layer 2140, and covering orifices 2145 and 2845. Gas permeable liquid impermeable filter elements 2130 are provided at each orifice. The molding 2910 is coupled to an external source of negative pressure via a tube element 2220.

According to some embodiments, a single filter element may be used extending underneath the length of the fluid communication passage and the two orifices. While the above example embodiment has been described as having two orifices, it will be understood that more than two orifices could be used, the fluid communication passage allowing the negative pressure to be communicated between the orifices.

FIG. 30 illustrates an alternative arrangement in which a single elongate orifice 2350 is provided in the cover layer 2140. First and second ends 2355, 2356 of the orifice 2350 are located in opposite corner regions of the cover layer 2140. A flexible molding 2360 is sealed around the orifice 2350 and allows negative pressure to be communicated through the cover layer 2140 along the length of the orifice 2350. The flexible molding 2360 may be formed by any suitable means as described above in relation to flexible molding 2910.

In use, the wound dressing is sealed over a wound site to form a wound cavity and an external source of negative pressure is applied to the orifice. If, due to the orientation of the wound dressing, wound exudate moves under the influence of gravity to collect around one end 2355 of the orifice 2350, a portion of the orifice 2350 near to the end 2355 will become blocked. However, a portion of the orifice near to the remaining end 2356 should remain clear, allowing continued application of negative pressure to the wound site.

As still further options the dressing can contain antimicrobial e.g. nanocrystalline silver agents on the wound contact layer and/or silver sulphur diazine in the absorbent layer. These may be used separately or together. These respectively kill micro-organisms in the wound and micro-organisms in the absorption matrix. As a still further option other active components, for example, pain suppressants, such as ibuprofen, may be included. Also agents which enhance cell activity, such as growth factors or that inhibit enzymes, such as matrix metalloproteinase inhibitors, such as tissue inhibitors of metalloproteinase (TIMPS) or zinc chelators could be utilized. As a still further option odor trapping elements such as activated carbon, cyclodextrine, zeolite or the like may be included in the absorbent layer or as a still further layer above the filter layer.

FIG. 31 illustrates a first, upper surface 3700 and a further, lower surface 3702 of a transmission layer 2105 according to an embodiment of the present disclosure. In the embodiment illustrated in FIG. 31 fibers 3703 of a woven layer extend between the first surface 3700 and the further surface 3702. It will be appreciated that according to further embodiments of the present disclosure if a foam layer is used as a transmission layer 2105 the connected strands forming the foam will act as spacer elements. As illustrated in FIG. 31 in a relaxed mode of operation, that is to say when in use, no negative pressure is applied to the wound dressing or negative pressure is applied to the wound dressing but no external force acts on the wound dressing then the fibers 3703 extend substantially perpendicular to the upper and lower surfaces keeping the surfaces in a spaced apart substantially parallel configuration.

FIG. 32 illustrates the transmission layer 2105 when an external force is exerted on the outside of the dressing. The external force can be a compressive force indicated by arrow A and/or a lateral force illustrated by arrow B in FIG. 32. As indicated either a compressive force or a lateral force acts to cause the fibers 3703 to lean to one side. This causes the upper and lower surfaces to become laterally offset with respect to each other as well as causing the thickness of the layer to reduce from a separation distance r indicated in FIG. 31 in a relaxed mode of operation to a compression distance

c illustrated in FIG. 32. The reduction in thickness effectively provides some "give" in the dressing even when the dressing is subject to negative pressure. It will be appreciated that the forces acting on the dressing may occur throughout the whole of the surface area of the dressing or only in one or more particular regions. In such a situation regions of the dressing can be in a relaxed mode of operation and further regions can be in a compressed mode of operation. As illustrated in FIG. 32 when a force is exerted on the transmission layer the fibers separating the upper and lower surfaces tend to lean to one side sharing a common lean angle.

Throughout this specification reference will be made to a relaxed mode of operation and a forced mode of operation. It is to be understood that the relaxed mode of operation corresponds to a natural state of the material either when no negative pressure is applied or when negative pressure is applied. In either situation no external force, caused for example by motion of a patient or an impact is in evidence. By contrast a forced mode of operation occurs when an external force whether compressive, lateral or other is brought to bear upon the wound dressing. Such forces can cause serious damage/prevent healing or a wound.

FIG. 33 illustrates how certain embodiments of the present disclosure can also operate to offset load forces. As illustrated in FIG. 33 if a force is exerted over a contact area 3900 in an upper surface 3700 of the transmission layer 2105 then this force is transmitted across and through the transmission layer and is exerted over a larger dissipation area 3901 against an underlying wound site. In the case of use of a 3D knit as a transmission layer this is because the relatively stiff spacer elements provide at least some lateral stiffness to the layer.

FIG. 34 illustrates the transmission layer 2105 and absorbent layer 2110 of some embodiments in more detail. The absorbent layer 2110 is located proximate to the upper surface 3700 of the transmission layer 2105 and is unbonded thereto according to certain embodiments of the present disclosure. When unbonded the absorbent layer 2110 is also able to move laterally with respect to the underlying transmission layer when a lateral or shear force is applied to the wound dressing. Also the absorbent layer is able to further compress when a compressive force illustrated in FIG. 35 acts on the wound dressing. As illustrated in FIG. 35 the absorbent layer 2110 decreases in thickness under a compressive force from a non-compressed thickness x illustrated in FIG. 34 to a compressed distance y illustrated in FIG. 35. The compressive force also acts to offset the upper and lower surfaces of the transmission layer as described above thus enhancing the "give" of the dressing. The ability for an upper surface 4201 to translate laterally with respect to a lower surface 4202 of the absorbent layer under a lateral or shearing force exerted on the wound dressing is illustrated in more detail in FIG. 36. This lateral motion causes the thickness x of the absorbent layer 2110 to reduce and the upper surface and lower surface of the absorbent layer to be offset with respect to each other. This effect can itself be sufficient to prevent shear forces exerted on the whole or part of the wound dressing from being transferred to an underlying wound bed. As can the corresponding effect in the transmission layer. However a combination enhances the cushioning effect. If the wound bed comprises a skin graft region the reduction of shear forces can be particularly advantageous.

It is to be noted that in use the dressing may be used "up-side down", at an angle or vertical. References to upper and lower are thus used for explanation purposes only.

FIG. 37 illustrates a cross-section, of a portion of an embodiment of a dressing shown in FIGS. 15A-16. In particular, FIG. 37 illustrates a magnified view of the wound contact layer 2102 which includes a lower surface 2101 and multiple perforations 2104 formed as through holes. An upper surface 2104 of the wound contact layer abuts a first layer 2300 of the transmission layer 2105. A further, upper, layer 2301 of the transmission layer 2105 is spaced apart from the first layer. The first and further layers of the transmission layer are kept apart in a spaced apart relationship by multiple mono-filament fiber spacers 2302 which act as resilient flexible pillars separating the two layers of the transmission layer. The upper layer 2301 of the transmission layer is adjacent a lower surface of the absorbent 2110 which, for example, is formed as a pad of fibrous cellulose material interspaced with super-absorbent particulate matter.

FIG. 38 illustrates the lower layer of the 3D fabric transmission layer in more detail. The 3D fabric layer 2105 is formed as a lower and upper knitted layer given a loft by the knitted structure. Rows of the knitted stitches may be referred to as a course of stitches. Columns of stitches may be referred to as a wale. A single monofilament fiber is knitted into the 3D fabric to form the multiple separating strands.

As illustrated in FIG. 38 there are apertures or openings formed between interlocked stitches in the lower layer of the transmission layer 2105. In use, wound exudate including liquid and semi-solid e.g. viscous slurry, suspensions of biological debris or the like and solid material will pass upwards through the perforations 2104 in the wound contact layer and through the openings in the inter knitted structure of the first layer 2300 of the transmission layer. The openings between the interconnected stitches have an average open area ranging from around 2250 microns to 450 microns. The particular open area in the first layer of the transmission layer will be determined by the materials and method of manufacture of the lower layer. FIG. 39 illustrates how an open area of openings in the further layer above the first layer (that is to say further away from the wound) can include openings which have a greater open area than the openings in the lower layer. In this way as wound exudate which includes semi-solid and solid matter moves from the wound bed at the wound site upwards into the wound dressing any particulate matter which is of a size small enough to pass through the relative small openings 2400 in the lower layer will certainly be able to pass through the larger area openings 2501 in the upper area. This helps avoid debris in the form of solid material collecting in the interstitial region between the monofilament fibers between the upper and lower layer. As shown in FIG. 39, the upper layer 2301 may include openings 2500 similar to the openings 2400 in the lower layer 2300. However, during the knitting process the upper surface is knitted so that larger open area openings 2501 are interspersed across the whole surface of the upper layer. As illustrated in FIG. 39 the larger open area openings 2501 can have an open range considerably larger (shown between 2700 to 800 microns). The lower layer 2300 thus acts to some extent as a filtering layer having openings 2400 which enable gas and liquid to pass freely therethrough but to prevent solid and semi-solid particulate matter which is too large from passing in to the interstitial region in the transmission layer 2105. This helps keep a flowpath along the transmission layer open.

By providing openings in an upper layer in the transmission layer which have a greater open area than any openings in the lower area build-up of solid particulate matter in the interstitial region between the upper and lower layers of the

transmission layer is avoided since any solid or semi-solid matter will flow along the channel and eventually be enabled to pass upwards through the larger openings where the material is taken up by the super-absorber/absorbent material.

The absorbent layer 2110 holds liquid collected during the application of negative pressure therapy. By having this layer in fluid communication with, and preferably in contact with, the layer of the transmission layer, the region of the transmission layer 2105 is kept at a moist environment. This helps avoid build-up and crusting of the exudate during use.

FIG. 40 illustrates an alternative material which could be utilized as the transmission layer in a wound dressing. In particular, FIG. 40 illustrates a lower surface of a 3D knit material which may be utilized as the transmission layer. Openings 2600 are formed in the surface which enables wound exudate and air to pass from the wound through a wound contact layer which would be located on the surface shown in FIG. 20 and through those openings. FIG. 41 illustrates an upper surface of the material shown in FIG. 40 and illustrates how larger openings 2700 may be formed in the upper surface.

Whilst certain embodiments of the present disclosure have so far been described in which the transmission layer is formed as a 3D knit layer, e.g., two layers spaced apart by a monofilament layer, it will be appreciated that certain embodiments of the present disclosure are not restricted to the use of such a material. In some embodiments, as an alternative to such a 3D knit material one or more layers of a wide variety of materials could be utilized. In each case, according to embodiments of the present disclosure, the openings presented by layers of the transmission layer are wider and wider as one moves away from the side of the dressing which, in use will be located proximate to the wound. In some embodiments, the transmission layer may be provided by multiple layers of open celled foam. In some embodiments, the foam is reticulated open cell foam. Preferably, the foam is hydrophilic or able to wick aqueous based fluids. The pore size in each layer is selected so that in the foam layer most proximate to the wound side in use the pores have a smallest size. If only one further foam layer is utilized that includes pore sizes which are greater than the pore sizes of the first layer. This helps avoid solid particulate being trapped in the lower layer which thus helps maintain the lower layer in an open configuration in which it is thus able to transmit air throughout the dressing. In certain embodiments, two, three, four or more foam layers may be included. The foam layers may be integrally formed, for example, by selecting a foam having a large pore size and then repeatedly dipping this to a lesser and lesser extent into material which will clog the pores or alternatively, the transmission layer formed by the multiple foam layers may be provided by laminating different types of foam in a layered arrangement or by securing such layers of foam in place in a known manner.

According to certain embodiments of the present disclosure, the transmission layer is formed by multiple layers of mesh instead of foam or 3D knit materials. For example, fine gauze mesh may be utilized for a wound facing side of the transmission layer and a Hessian mesh having a larger pore size may be located on a distal side of the gauze mesh facing away from the wound in use. The one, two, three or more layers of mesh can be secured together in an appropriate manner, such as being stitched or adhered together or the like. The resultant mat of fibers provides a transmittal layer through which air can be transmitted in the dressing but by selecting the opening sizes in the meshes as one moves

through the dressing away from the wound contact side, the accumulation of solid particulate matter in lower layers can be avoided.

FIG. 42 illustrates an embodiment of a TNP wound treatment comprising a wound dressing 2100 in combination with a pump 2800. As stated above, the wound dressing 2100 can be any wound dressing embodiment disclosed herein including without limitation dressing embodiment 100 or have any combination of features of any number of wound dressing embodiments disclosed herein. Here, the dressing 2100 may be placed over a wound as described previously, and a conduit 2220 may then be connected to the port 2150, although in some embodiments the dressing 2100 may be provided with at least a portion of the conduit 2220 preattached to the port 2150. Preferably, the dressing 2100 is provided as a single article with all wound dressing elements (including the port 2150) pre-attached and integrated into a single unit. The wound dressing 2100 may then be connected, via the conduit 2220, to a source of negative pressure such as the pump 2800. The pump 2800 can be miniaturized and portable, although larger conventional pumps may also be used with the dressing 2100. In some embodiments, the pump 2800 may be attached or mounted onto or adjacent the dressing 2100. A connector 2221 may also be provided so as to permit the conduit 2220 leading to the wound dressing 2100 to be disconnected from the pump, which may be useful for example during dressing changes.

FIGS. 43A-D illustrate the use of an embodiment of a TNP wound treatment system being used to treat a wound site on a patient. FIG. 43A shows a wound site 2190 being cleaned and prepared for treatment. Here, the healthy skin surrounding the wound site 2190 is preferably cleaned and excess hair removed or shaved. The wound site 2190 may also be irrigated with sterile saline solution if necessary. Optionally, a skin protectant may be applied to the skin surrounding the wound site 2190. If necessary, a wound packing material, such as foam or gauze, may be placed in the wound site 2190. This may be preferable if the wound site 2190 is a deeper wound.

After the skin surrounding the wound site 2190 is dry, and with reference now to FIG. 43B, the wound dressing 2100 may be positioned and placed over the wound site 2190. Preferably, the wound dressing 2100 is placed with the wound contact layer 2102 over and/or in contact with the wound site 2190. In some embodiments, an adhesive layer is provided on the lower surface 2101 of the wound contact layer 2102, which may in some cases be protected by an optional release layer to be removed prior to placement of the wound dressing 2100 over the wound site 2190. Preferably, the dressing 2100 is positioned such that the port 2150 is in a raised position with respect to the remainder of the dressing 2100 so as to avoid fluid pooling around the port. In some embodiments, the dressing 2100 is positioned so that the port 2150 is not directly overlying the wound, and is level with or at a higher point than the wound. To help ensure adequate sealing for TNP, the edges of the dressing 2100 are preferably smoothed over to avoid creases or folds.

With reference now to FIG. 43C, the dressing 2100 is connected to the pump 2800. The pump 2800 is configured to apply negative pressure to the wound site via the dressing 2100, and typically through a conduit. In some embodiments, and as described above in FIG. 42, a connector may be used to join the conduit from the dressing 2100 to the pump 2800. Upon the application of negative pressure with the pump 2800, the dressing 2100 may in some embodiments partially collapse and present a wrinkled appearance as a result of the evacuation of some or all of the air

underneath the dressing 2100. In some embodiments, the pump 2800 may be configured to detect if any leaks are present in the dressing 2100, such as at the interface between the dressing 2100 and the skin surrounding the wound site 2190. Should a leak be found, such leak is preferably remedied prior to continuing treatment.

Turning to FIG. 43D, additional fixation strips 2195 may also be attached around the edges of the dressing 2100. Such fixation strips 2195 may be advantageous in some situations so as to provide additional sealing against the skin of the patient surrounding the wound site 2190. For example, the fixation strips 2195 may provide additional sealing for when a patient is more mobile. In some cases, the fixation strips 2195 may be used prior to activation of the pump 2800, particularly if the dressing 2100 is placed over a difficult to reach or contoured area.

Treatment of the wound site 2190 preferably continues until the wound has reached a desired level of healing. In some embodiments, it may be desirable to replace the dressing 2100 after a certain time period has elapsed, or if the dressing is full of wound fluids. During such changes, the pump 2800 may be kept, with just the dressing 2100 being changed.

With the some embodiments of the present disclosure, a wound dressing is provided that helps improve patient concordance with instructions for use, helps improve patients' quality of life, and also helps a clinician observe and monitor a patient's wound.

It will be clear to a person skilled in the art that features described in relation to any of the embodiments described above can be applicable interchangeably between the different embodiments. The embodiments described above are examples to illustrate various features of the present invention or inventions.

Throughout the description and claims of this specification, the words "comprise" and "contain" and variations of them mean "including but not limited to", and they are not intended to (and do not) exclude other moieties, additives, components, integers or steps. Throughout the description and claims of this specification, the singular encompasses the plural unless the context otherwise requires. In particular, where the indefinite article is used, the specification is to be understood as contemplating plurality as well as singularity, unless the context requires otherwise.

Features, integers, characteristics, compounds, chemical moieties or groups described in conjunction with a particular aspect, embodiment or example of the present disclosure are to be understood to be applicable to any other aspect, embodiment or example described herein unless incompatible therewith. All of the features disclosed in this specification (including any accompanying claims, abstract and drawings), and/or all of the steps of any method or process so disclosed, may be combined in any combination, except combinations where at least some of such features and/or steps are mutually exclusive. The invention is not restricted to the details of any foregoing embodiments. The invention extends to any novel one, or any novel combination, of the features disclosed in this specification (including any accompanying claims, abstract and drawings), or to any novel one, or any novel combination, of the steps of any method or process so disclosed.

The reader's attention is directed to all papers and documents which are filed concurrently with or previous to this specification in connection with this application and which are open to public inspection with this specification, and the contents of all such papers and documents are incorporated herein by reference.

The invention claimed is:

1. A wound dressing, comprising:
a wound contact layer;
a cover layer sealed to the wound contact layer;
 an absorbent layer for absorbing wound exudate *posi-* 5
tioned between the wound contact layer and the cover
layer; and
at least one layer positioned between the absorbent layer
and the wound contact layer; wherein a dimension of 10
the absorbent layer is larger than a dimension of the at
least one layer such that a radially outer region of the
absorbent layer forms an enclosure with the wound
contact layer around the at least one layer;
 wherein the [dressing is shaped to include] *wound contact*
layer, cover layer, and absorbent layer are shaped in a 15
conformable shape including a plurality of sub-areas,
 wherein the [dressing] *conformable shape* has rota-
 tional symmetry *around a center point of the conform-*
able shape, and the sub areas define areas of the
 dressing that are formable in different directions with 20
 respect to each other.
2. The wound dressing of claim 1, wherein the dressing
 comprises four sub-areas.
3. The wound dressing of claim 1, further comprising [at
 least one of a wound contact layer, a foam layer, an odour 25
 controlling element,] a shielding layer [and a cover layer].
4. A wound dressing comprising:
 a wound contact layer;
 a cover layer sealed to the wound contact layer; [and]
 an absorbent layer for absorbing wound exudate posi- 30
 tioned between the wound contact layer and the cover
 layer; *and*
a masking layer for at least partially obscuring a view of
wound exudate absorbed by the absorbent layer in use, 35
the masking layer positioned between the absorbent
layer and the cover layer;
 wherein the wound contact layer, cover layer, [and] absor-
 bent layer *and masking layer* are shaped in a conform-
 able shape including a plurality of sub-areas, wherein
 the sub areas define areas of the wound dressing that are 40
 formable in different directions with respect to each
 other;
 wherein the conformable shape has rotational symmetry
 around a center point of the conformable shape, *and*
wherein the conformable shape of the masking layer has 45
a smaller dimension than the conformable shape of the
absorbent layer whereby the masking layer is posi-
tioned over a central region of the absorbent layer and
is not positioned over a radially outer border region of
the absorbent layer.
5. The wound dressing of claim 4, wherein the conform-
 able shape comprises four rounded lobes extending from a
 central portion of the dressing.
- [6. The wound dressing of claim 4, further comprising a
 masking layer for at least partially obscuring a view of 55
 wound exudate absorbed by the absorbent layer in use, the
 masking layer positioned between the absorbent layer and
 the cover layer.]
- [7. The wound dressing of claim 6, wherein the masking
 layer is formed in the conformable shape including the 60
 plurality of sub-areas.]
- [8. The wound dressing of claim 7, wherein the conform-
 able shape of the masking layer has a smaller dimension than
 the conformable shape of the absorbent layer whereby the
 masking layer is positioned over a central region of the 65
 absorbent layer and is not positioned over a radially outer
 border region of the absorbent layer.]

9. The wound dressing of claim [6] 4, wherein the cover
 layer and the masking layer are permeable to one or both of
 gas and vapour.

10. The wound dressing of claim 9, wherein the masking
 layer comprises, or is coated with, a material having size-
 exclusion properties for selectively permitting or preventing
 passage of molecules of a predetermined size or weight, the
 molecules comprising proteins.

11. The wound dressing of claim [6] 4, further comprising
 a shielding layer positioned above the absorbent layer,
 wherein the shielding layer comprises the masking layer, the
 shielding layer configured for spreading pressure applied to
 the wound dressing at a first area over a second area, wherein
 the second area is larger than the first area.

12. The wound dressing of claim 11, wherein the shielding
 layer increases the area over which a pressure applied to the
 dressing is transferred by 25% or more [or] of the initial area
 of application.

13. The wound dressing of claim 11, wherein the shielding
 layer comprises two or more sub-layers, wherein a first
 sub-layer comprises through holes and a further sub-layer
 comprises through holes and the through holes of the first
 sub-layer are offset from the through holes of the further
 sub-layer.

14. The wound dressing of claim 4, further comprising at
 least one layer positioned between the absorbent layer and
 the wound contact layer; wherein a dimension of the absor-
 bent layer is larger than a dimension of the at least one layer
 such that a radially outer region of the absorbent layer forms
 an enclosure with the wound contact layer around the at least
 one layer.

15. The wound dressing of claim 14, wherein the at least
 one layer comprises a foam layer positioned between the
 absorbent layer and the wound contact layer.

16. The wound dressing of claim 14, wherein the at least
 one layer comprises an odour controlling element positioned
 between the absorbent layer and the wound contact layer.

17. The wound dressing of claim 4, wherein the wound
 contact layer carries an adhesive portion on a lower surface
 thereof, the adhesive portion for forming a substantially
 fluid tight seal over the wound site.

18. The wound dressing of claim 4, wherein the wound
 contact layer and cover layer are moisture vapor permeable.

19. The wound dressing of claim 18, further comprising
 a moisture vapor permeable adhesive sealing the cover layer
 and the wound contact layer around [the] a border region of
 the wound dressing.

20. The wound dressing of claim 4, wherein the cover
 layer comprises a translucent film having a moisture vapour
 permeability of 500 g/m²/24 hours or more.

21. The wound dressing of claim 4, wherein the wound
 dressing has a border region and a central region, wherein
 the cover layer is sealed to the wound contact layer within
 the border region, and wherein the absorbent layer is posi-
 tioned within the central region.

22. *The wound dressing of claim 1, wherein the plurality*
of sub-areas comprise four rounded lobes extending from a
central portion of the dressing.

23. *The wound dressing of claim 22, wherein a shape of*
the absorbent layer matches a shape of a border around the
four rounded lobes.

24. *The wound dressing of claim 23, further comprising a*
border region around the absorbent layer, wherein a width
of the border region is approximately equal around the
wound dressing.

55

25. The wound dressing of claim 1, wherein the at least one layer comprises a foam layer positioned between the absorbent layer and the wound contact layer.

26. The wound dressing of claim 1, wherein the at least one layer comprises an odour controlling element positioned between the absorbent layer and the wound contact layer.

27. A wound dressing comprising:

a wound contact layer;

a cover layer sealed to the wound contact layer;

an absorbent layer for absorbing wound exudate positioned between the wound contact layer and the cover layer; and

a masking layer for at least partially obscuring a view of wound exudate absorbed by the absorbent layer in use, the masking layer positioned between the absorbent layer and the cover layer;

wherein the wound contact layer, cover layer, absorbent layer and the masking layer are shaped in a conformable shape including a plurality of sub-areas, wherein the sub areas define areas of the wound dressing that are formable in different directions with respect to each other;

wherein the conformable shape has rotational symmetry around a center point of the conformable shape;

wherein the cover layer and the masking layer are permeable to one or both of gas and vapour;

wherein the masking layer comprises a material having size-exclusion properties for selectively permitting or preventing passage of molecules of a predetermined size or weight, the molecules comprising proteins.

56

28. The wound dressing of claim 27, wherein the conformable shape comprises four rounded lobes extending from a central portion of the dressing.

29. A wound dressing comprising:

a wound contact layer;

a cover layer sealed to the wound contact layer;

an absorbent layer for absorbing wound exudate positioned between the wound contact layer and the cover layer; and

a shielding layer positioned above the absorbent layer, the shielding layer configured for spreading pressure applied to the wound dressing at a first area over a second area, wherein the second area is larger than the first area;

wherein the wound contact layer, cover layer, and absorbent layer are shaped in a conformable shape including a plurality of sub-areas, wherein the sub areas define areas of the wound dressing that are formable in different directions with respect to each other;

wherein the conformable shape has rotational symmetry around a center point of the conformable shape;

wherein the shielding layer comprises two or more sub-layers, wherein a first sub-layer comprises through holes and a further sub-layer comprises through holes and the through holes of the first sub-layer are offset from the through holes of the further sub-layer.

30. The wound dressing of claim 29, wherein the conformable shape comprises four rounded lobes extending from a central portion of the dressing.

* * * * *