



US00RE48435E

(19) **United States**
(12) **Reissued Patent**
Greene

(10) **Patent Number:** **US RE48,435 E**
(45) **Date of Reissued Patent:** ***Feb. 9, 2021**

(54) **TUNING MATCHING CIRCUITS FOR TRANSMITTER AND RECEIVER BANDS AS A FUNCTION OF THE TRANSMITTER METRICS**

(71) Applicant: **NXP USA, Inc.**, Austin, TX (US)

(72) Inventor: **Matthew Russell Greene**, Crystal Lake, IL (US)

(73) Assignee: **NXP USA, Inc.**, Austin, TX (US)

(*) Notice: This patent is subject to a terminal disclaimer.

(21) Appl. No.: **16/372,838**

(22) Filed: **Apr. 2, 2019**

Related U.S. Patent Documents

Reissue of:

(64) Patent No.: **8,798,555**
Issued: **Aug. 5, 2014**
Appl. No.: **13/693,388**
Filed: **Dec. 4, 2012**

U.S. Applications:

(63) Continuation of application No. 14/716,014, filed on May 19, 2015, which is an application for the reissue of Pat. No. 8,798,555, which is a continuation of application No. 13/168,529, filed on Jun. 24, 2011, now Pat. No. 8,428,523, which is a continuation of application No. 11/940,309, filed on Nov. 14, 2007,
(Continued)

(51) **Int. Cl.**

H04B 1/40 (2015.01)
H04W 24/02 (2009.01)
H03H 7/40 (2006.01)
H04B 1/04 (2006.01)

(52) **U.S. Cl.**
CPC **H04W 24/02** (2013.01); **H03H 7/40** (2013.01); **H04B 1/0458** (2013.01)

(58) **Field of Classification Search**
CPC . H04B 1/406; H04B 1/44; H04B 1/54; H04B 1/3822; H04B 1/38; H04W 52/04; H01Q 7/005
USPC 455/77, 522, 73, 125
See application file for complete search history.

(56) **References Cited**

U.S. PATENT DOCUMENTS

2,745,067 A 5/1956 True
3,117,279 A 1/1964 Ludvigson
(Continued)

FOREIGN PATENT DOCUMENTS

CA 2914562 6/2016
CN 101640949 A 2/2010
(Continued)

OTHER PUBLICATIONS

Communication pursuant to Article 94(3) EPC issued by the European Patent Office, dated Nov. 16, 2017. European Patent Application 12177197.6.

(Continued)

Primary Examiner — Minh Dieu Nguyen

(57) **ABSTRACT**

A system can obtain an operational metric associated with the transceiver, determine a target figure of merit based on a compromise between a desired transmitter performance and a desired receiver, determine a current figure of merit based on the operational metric, and adjust the variable reactance component of the impedance matching circuit based on a comparison of the current figure of merit with the target figure of merit. Other embodiments are disclosed.

33 Claims, 8 Drawing Sheets

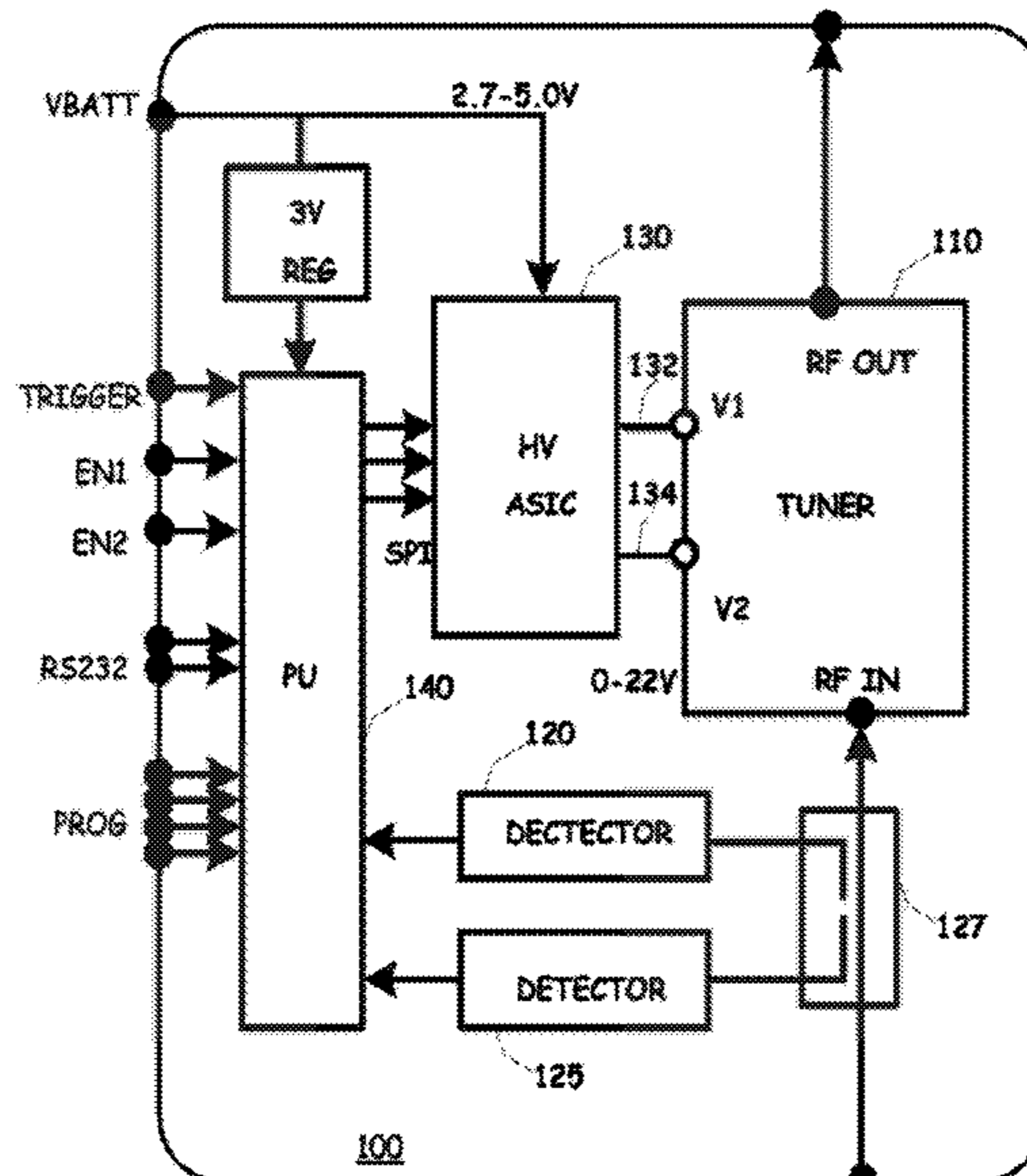

Related U.S. Application Data

now Pat. No. 7,991,363, which is an application for the reissue of Pat. No. 8,798,555, application No. 16/372,838, filed on Apr. 2, 2019.

(56)

References Cited

U.S. PATENT DOCUMENTS

3,160,832 A	12/1964	Beitman	5,679,624 A	10/1997	Das
3,390,337 A	6/1968	Beitman	5,689,219 A	11/1997	Piirainen
3,443,231 A	5/1969	Roza	5,693,429 A	12/1997	Sengupta
3,509,500 A	4/1970	McNair	5,694,134 A	12/1997	Barnes
3,571,716 A	3/1971	Hill	5,699,071 A	12/1997	Urakami
3,590,385 A	6/1971	Sabo	5,721,194 A	2/1998	Yandrofski
3,601,717 A	8/1971	Kuecken	5,766,697 A	6/1998	Sengupta
3,742,279 A	6/1973	Kupsky	5,777,581 A	7/1998	Lilly
3,749,491 A	7/1973	Maxfield et al.	5,778,308 A	7/1998	Sroka
3,794,941 A	2/1974	Templin	5,786,727 A	7/1998	Sigmon
3,919,644 A	11/1975	Smolka	5,812,572 A	9/1998	King
3,990,024 A	11/1976	Hou	5,812,943 A	9/1998	Suzuki
3,995,237 A	11/1976	Brunner	5,830,591 A	11/1998	Sengupta
4,186,359 A	1/1980	Kaegebein	5,846,893 A	12/1998	Sengupta
4,201,960 A	5/1980	Skutta	5,874,926 A	2/1999	Tsuru
4,227,256 A	10/1980	O'Keefe	5,880,635 A	3/1999	Satoh
4,383,441 A	5/1983	Willis	5,886,867 A	3/1999	Chivukula
4,476,578 A	10/1984	Gaudin	5,892,482 A	4/1999	Coleman et al.
4,493,112 A	1/1985	Bruene	5,926,751 A	7/1999	Vlahos et al.
4,509,019 A	4/1985	Banu et al.	5,929,717 A	7/1999	Richardson
4,777,490 A	10/1988	Sharma	5,940,030 A	8/1999	Hampel et al.
4,799,066 A	1/1989	Deacon	5,963,871 A	10/1999	Zhinong
4,965,607 A	10/1990	Wilkins	5,969,582 A	10/1999	Boesch
4,970,478 A	11/1990	Townley et al.	5,973,568 A	10/1999	Shapiro et al.
4,980,656 A	12/1990	Duffalo	5,982,099 A	11/1999	Barnes et al.
5,032,805 A	7/1991	Elmer	5,990,766 A	11/1999	Zhang
5,136,478 A	8/1992	Bruder	6,008,759 A	12/1999	Tangemann et al.
5,142,255 A	8/1992	Chang	6,009,124 A	12/1999	Smith
5,177,670 A	1/1993	Shinohara	6,020,787 A	2/2000	Kim
5,195,045 A	3/1993	Keane	6,020,795 A	2/2000	Kim
5,200,826 A	4/1993	Seong	6,029,075 A	2/2000	Das
5,212,463 A	5/1993	Babbitt	6,045,932 A	4/2000	Jia
5,215,463 A	6/1993	Marshall et al.	6,061,025 A	5/2000	Jackson
5,216,392 A	6/1993	Fraser et al.	6,064,865 A	5/2000	Kuo et al.
5,230,091 A	7/1993	Vaisanen et al.	6,074,971 A	6/2000	Chiu
5,243,358 A	9/1993	Sanford	6,096,127 A	8/2000	Dimos
5,258,728 A	11/1993	Taniyoshi	6,100,733 A	8/2000	Dortu
5,276,912 A	1/1994	Siwiak	6,101,102 A	8/2000	Brand
5,301,358 A	4/1994	Gaskill	6,115,585 A	9/2000	Matero
5,307,033 A	4/1994	Koscica	6,125,266 A	9/2000	Matero et al.
5,310,358 A	5/1994	Johnson	6,133,868 A	10/2000	Butler et al.
5,312,790 A	5/1994	Sengupta	6,133,883 A	10/2000	Munson
5,334,958 A	8/1994	Babbitt	6,172,385 B1	1/2001	Duncombe
5,361,403 A	11/1994	Dent	6,215,644 B1	4/2001	Dhuler
5,371,473 A	12/1994	Trinh	6,242,989 B1	6/2001	Barber
5,409,889 A	4/1995	Das	6,266,528 B1	7/2001	Farzaneh
5,427,988 A	6/1995	Sengupta	6,281,748 B1	8/2001	Klomsdorf et al.
5,430,417 A	7/1995	Martin	6,281,847 B1	8/2001	Lee
5,446,447 A	8/1995	Carney	6,309,895 B1	10/2001	Jaing
5,448,252 A	9/1995	Ali	6,343,208 B1	1/2002	Ying
5,451,567 A	9/1995	Das	6,377,142 B1	4/2002	Chiu
5,451,914 A	9/1995	Stengel	6,377,217 B1	4/2002	Zhu
5,457,394 A	10/1995	McEwan	6,377,440 B1	4/2002	Zhu
5,472,935 A	12/1995	Yandrofski	6,384,785 B1	5/2002	Kamogawa
5,479,139 A	12/1995	Koscica	6,404,614 B1	6/2002	Zhu
5,486,491 A	1/1996	Sengupta	6,408,190 B1	6/2002	Ying
5,496,795 A	3/1996	Das	6,414,562 B1	7/2002	Bouisse
5,502,372 A	3/1996	Quan	6,415,562 B1	7/2002	Donaghue
5,524,281 A	6/1996	Bradley	6,438,360 B1	8/2002	Alberth, Jr. et al.
5,548,837 A	8/1996	Hess et al.	6,452,776 B1	9/2002	Chakravorty
5,561,086 A	10/1996	Cygan	6,461,930 B2	10/2002	Akram
5,561,407 A	10/1996	Koscica	6,466,774 B1	10/2002	Okabe
5,564,086 A	10/1996	Cygan	6,492,883 B2	12/2002	Liang
5,583,359 A	12/1996	Ng et al.	6,514,895 B1	2/2003	Chiu
5,589,844 A	12/1996	Belcher et al.	6,525,630 B1	2/2003	Zhu
5,593,495 A	1/1997	Masuda	6,531,936 B1	3/2003	Chiu
5,635,433 A	6/1997	Sengupta	6,535,076 B2	3/2003	Partridge
5,635,434 A	6/1997	Sengupta	6,535,722 B1	3/2003	Rosen
5,640,042 A	6/1997	Koscica	6,538,603 B1	3/2003	Chen
			6,556,102 B1	4/2003	Sengupta
			6,556,814 B1	4/2003	Klomsdorf
			6,570,462 B2	5/2003	Edmonson
			6,590,468 B2	7/2003	du Toit
			6,590,541 B1	7/2003	Schultze
			6,597,265 B2	7/2003	Liang
			6,608,603 B2	8/2003	Alexopoulos
			6,624,786 B2	9/2003	Boyle
			6,628,962 B1	9/2003	Katsura et al.
			6,640,085 B1	10/2003	Chatzipetros

(56)

References Cited

U.S. PATENT DOCUMENTS

6,657,595	B1	12/2003	Phillips et al.	7,711,337	B2	5/2010	McKinzie
6,661,638	B2	12/2003	Jackson et al.	7,714,676	B2	5/2010	McKinzie
6,670,256	B2	12/2003	Yang	7,714,678	B2	5/2010	du Toit et al.
6,710,651	B2	3/2004	Forrester	7,728,693	B2	6/2010	du Toit et al.
6,724,611	B1	4/2004	Mosley	7,760,699	B1	7/2010	Malik
6,724,890	B1	4/2004	Bareis	7,768,400	B2	8/2010	Lawrence et al.
6,737,179	B2	5/2004	Sengupta	7,786,819	B2	8/2010	Ella
6,747,522	B2	6/2004	Pietruszynski et al.	7,795,990	B2	9/2010	du Toit
6,759,918	B2	7/2004	Du Toit	7,830,320	B2	11/2010	Shamblin et al.
6,765,540	B2	7/2004	Toncich	7,852,170	B2	12/2010	McKinzie
6,768,472	B2	7/2004	Alexopoulos	7,856,228	B2	12/2010	Lekutai et al.
6,774,077	B2	8/2004	Sengupta	7,865,154	B2	1/2011	Mendolia
6,795,712	B1	9/2004	Vakilian	7,907,094	B2	3/2011	Kakitsu et al.
6,825,818	B2	11/2004	Toncich	7,917,104	B2	3/2011	Manssen et al.
6,839,028	B2	1/2005	Lee	7,940,223	B2	5/2011	Dou et al.
6,845,126	B2	1/2005	Dent	7,949,309	B2	5/2011	Rofougaran
6,859,104	B2	2/2005	Toncich	7,969,257	B2	6/2011	du Toit
6,862,432	B1	3/2005	Kim	7,983,615	B2	7/2011	Bryce et al.
6,864,757	B2	3/2005	Du Toit	7,991,363	B2	8/2011	Greene
6,868,260	B2	3/2005	Jagielski	8,008,982	B2	8/2011	McKinzie
6,875,655	B2	4/2005	Lin	8,072,285	B2	12/2011	Spears
6,882,245	B2	4/2005	Utsunomiya	8,112,043	B2	2/2012	Knudsen et al.
6,888,714	B2	5/2005	Shaw	8,170,510	B2	5/2012	Knudsen et al.
6,905,989	B2	6/2005	Ellis	8,190,109	B2	5/2012	Ali et al.
6,906,653	B2	6/2005	Uno	8,204,446	B2	6/2012	Scheer
6,907,234	B2	6/2005	Karr	8,213,886	B2	7/2012	Blin
6,914,487	B1	7/2005	Doyle et al.	8,217,731	B2	7/2012	McKinzie et al.
6,920,315	B1	7/2005	Wilcox et al.	8,217,732	B2	7/2012	McKinzie
6,922,330	B2	7/2005	Nielsen	8,299,867	B2	10/2012	McKinzie
6,943,078	B1	9/2005	Zheng	8,320,850	B1	11/2012	Khlat
6,946,847	B2	9/2005	Nishimori	8,325,097	B2	12/2012	McKinzie, III et al.
6,949,442	B2	9/2005	Barth	8,405,563	B2	3/2013	McKinzie et al.
6,961,368	B2	11/2005	Dent	8,421,548	B2	4/2013	Spears et al.
6,964,296	B2	11/2005	Memory	8,432,234	B2	4/2013	Manssen et al.
6,965,837	B2	11/2005	Vintola	8,442,457	B2	5/2013	Harel et al.
6,987,493	B2	1/2006	Chen	8,454,882	B2	6/2013	Chan et al.
6,993,297	B2	1/2006	Smith	8,457,569	B2	6/2013	Blin
6,999,297	B1	2/2006	Klee	8,472,888	B2	6/2013	Manssen et al.
7,009,455	B2	3/2006	Toncich	8,478,344	B2	7/2013	Rofougaran et al.
7,071,776	B2	7/2006	Forrester	8,543,123	B2	9/2013	Moon et al.
7,106,715	B1	9/2006	Kelton	8,543,176	B1	9/2013	Daniel et al.
7,107,033	B2	9/2006	du Toit	8,558,633	B2	10/2013	McKinzie, III
7,113,614	B2	9/2006	Rhoads	8,564,381	B2	10/2013	McKinzie
7,151,411	B2	12/2006	Martin	8,594,584	B2	11/2013	Greene et al.
7,176,634	B2	2/2007	Kitamura	8,620,236	B2	12/2013	Manssen et al.
7,176,845	B2	2/2007	Fabrega-Sanchez	8,620,246	B2	12/2013	McKinzie et al.
7,180,467	B2	2/2007	Fabrega-Sanchez	8,620,247	B2	12/2013	McKinzie et al.
7,218,186	B2	5/2007	Chen et al.	8,655,286	B2	2/2014	Mendolia
7,221,327	B2	5/2007	Toncich	8,674,783	B2	3/2014	Spears et al.
7,298,329	B2	11/2007	Diament	8,680,934	B2	3/2014	McKinzie et al.
7,299,018	B2	11/2007	Van Rump	8,693,963	B2	4/2014	du Toit et al.
7,312,118	B2	12/2007	Kiyotoshi	8,712,340	B2	4/2014	Hoirup et al.
7,332,980	B2	2/2008	Zhu	8,712,348	B2	4/2014	Brobston et al.
7,332,981	B2	2/2008	Matsuno	8,773,019	B2	7/2014	Pham et al.
7,339,527	B2	3/2008	Sager	8,774,743	B2	7/2014	Ali et al.
7,369,828	B2	5/2008	Shamsaifar	8,787,845	B2	7/2014	Manssen et al.
7,426,373	B2	9/2008	Clingman	8,803,631	B2	8/2014	Greene et al.
7,427,949	B2	9/2008	Channabasappa et al.	8,860,525	B2	10/2014	Spears et al.
7,453,405	B2	11/2008	Nishikido et al.	8,948,889	B2	2/2015	Spears et al.
7,468,638	B1	12/2008	Tsai	8,957,742	B2	2/2015	Spears et al.
7,469,129	B2	12/2008	Blaker et al.	9,026,062	B2	5/2015	Greene et al.
7,528,674	B2	5/2009	Kato et al.	9,083,405	B2	7/2015	Christoffersson et al.
7,531,011	B2	5/2009	Yamasaki	9,119,152	B2	8/2015	Blin
7,535,080	B2	5/2009	Zeng et al.	9,231,643	B2	1/2016	Greene et al.
7,535,312	B2	5/2009	McKinzie	9,374,113	B2	6/2016	Manssen et al.
7,539,527	B2	5/2009	Jang	9,379,454	B2	6/2016	Rabe et al.
7,557,507	B2	7/2009	Wu	9,406,444	B2	8/2016	McKinzie et al.
7,567,782	B2	7/2009	Liu et al.	9,473,194	B2	10/2016	Domino et al.
7,596,357	B2	9/2009	Nakamata	9,698,758	B2	7/2017	Spears et al.
7,633,355	B2	12/2009	Matsuo	9,698,858	B2	7/2017	Hoirup et al.
7,642,879	B2	1/2010	Matsuno	9,742,375	B2	8/2017	Manssen et al.
7,655,530	B2	2/2010	Hosking	9,762,416	B2	9/2017	Mandegaran et al.
7,667,663	B2	2/2010	Hsiao	9,768,752	B2	9/2017	du Toit et al.
7,671,693	B2	3/2010	Brobston et al.	9,768,810	B2	9/2017	Greene et al.
7,705,692	B2	4/2010	Fukamachi et al.	9,853,363	B2	12/2017	Ali et al.
				9,935,674	B2	4/2018	Hoirup et al.
				2002/0008672	A1	1/2002	Gothard et al.
				2002/0030566	A1	3/2002	Bozler
				2002/0047154	A1	4/2002	Sowlati et al.

(56)

References Cited

U.S. PATENT DOCUMENTS

2002/0079982	A1	6/2002	Lafleur et al.	2007/0001924	A1	1/2007	Hirabayashi et al.
2002/0109642	A1	8/2002	Gee et al.	2007/0013483	A1	1/2007	Stewart
2002/0118075	A1	8/2002	Ohwada	2007/0035458	A1	2/2007	Ohba
2002/0145483	A1	10/2002	Bouisse	2007/0042725	A1	2/2007	Poilasne
2002/0167963	A1	11/2002	Joa-Ng	2007/0042734	A1	2/2007	Ryu
2002/0183013	A1	12/2002	Auckland et al.	2007/0063788	A1	3/2007	Zhu
2002/0187780	A1	12/2002	Souissi	2007/0077956	A1	4/2007	Julian et al.
2002/0191703	A1	12/2002	Ling et al.	2007/0080888	A1	4/2007	Mohamadi
2002/0193088	A1	12/2002	Jung	2007/0082611	A1*	4/2007	Terranova et al. 455/41.1
2003/0060227	A1*	3/2003	Sekine et al. 455/550	2007/0085609	A1	4/2007	Itkin
2003/0071300	A1	4/2003	Yashima	2007/0091006	A1	4/2007	Thober et al.
2003/0114124	A1	6/2003	Higuchi	2007/0093282	A1	4/2007	Chang et al.
2003/0137464	A1	7/2003	Foti et al.	2007/0109716	A1	5/2007	Martin et al.
2003/0142022	A1	7/2003	Ollikainen	2007/0111681	A1	5/2007	Alberth et al.
2003/0184319	A1	10/2003	Nishimori et al.	2007/0121267	A1	5/2007	Kotani et al.
2003/0193997	A1	10/2003	Dent	2007/0142011	A1	6/2007	Shatara
2003/0199286	A1	10/2003	du Toit	2007/0142014	A1	6/2007	Wilcox
2003/0210203	A1	11/2003	Phillips et al.	2007/0149146	A1	6/2007	Hwang
2003/0210206	A1	11/2003	Phillips	2007/0171879	A1	7/2007	Bourque
2003/0216150	A1	11/2003	Ueda	2007/0182636	A1	8/2007	Carlson
2003/0232607	A1	12/2003	Le Bars	2007/0184825	A1	8/2007	Lim et al.
2004/0009754	A1	1/2004	Smith	2007/0194859	A1	8/2007	Brobston
2004/0090372	A1	5/2004	Nallo	2007/0197180	A1	8/2007	McKinzie et al.
2004/0100341	A1	5/2004	Luetzelschwab et al.	2007/0200766	A1	8/2007	McKinzie
2004/0125027	A1	7/2004	Rubinshteyn et al.	2007/0200773	A1	8/2007	Dou et al.
2004/0127178	A1	7/2004	Kuffner	2007/0210899	A1	9/2007	Kato et al.
2004/0137950	A1	7/2004	Bolin	2007/0222697	A1	9/2007	Caimi et al.
2004/0202399	A1	10/2004	Kochergin	2007/0248238	A1	10/2007	Abreu et al.
2004/0204027	A1	10/2004	Park et al.	2007/0285326	A1	12/2007	McKinzie
2004/0227176	A1	11/2004	York	2007/0293176	A1	12/2007	Yu
2004/0232982	A1	11/2004	Itchitsubo et al.	2008/0007478	A1	1/2008	Jung
2004/0257293	A1	12/2004	Friedrich et al.	2008/0018541	A1	1/2008	Pang
2004/0263411	A1	12/2004	Fabrega-Sanchez et al.	2008/0030165	A1	2/2008	Lisac et al.
2004/0264610	A1	12/2004	Marro et al.	2008/0051096	A1	2/2008	Rao et al.
2005/0007291	A1	1/2005	Fabrega-Sanchez	2008/0055016	A1	3/2008	Morris, III et al.
2005/0032488	A1	2/2005	Pehlke	2008/0055168	A1	3/2008	Massey et al.
2005/0032541	A1	2/2005	Wang	2008/0081670	A1	4/2008	Rofougaran
2005/0042994	A1	2/2005	Otaka	2008/0090539	A1	4/2008	Thompson
2005/0059362	A1	3/2005	Kalajo	2008/0090573	A1	4/2008	Kim et al.
2005/0082636	A1	4/2005	Yashima	2008/0094149	A1	4/2008	Brobston
2005/0083234	A1	4/2005	Poilasne et al.	2008/0106350	A1	5/2008	McKinzie
2005/0085204	A1	4/2005	Poilasne et al.	2008/0111748	A1	5/2008	Dunn et al.
2005/0093624	A1	5/2005	Forrester et al.	2008/0122553	A1	5/2008	McKinzie
2005/0130608	A1	6/2005	Forse	2008/0122723	A1	5/2008	Rofougaran
2005/0130699	A1	6/2005	Kim	2008/0129612	A1	6/2008	Wang
2005/0145987	A1	7/2005	Okuda et al.	2008/0158076	A1	7/2008	Walley
2005/0208960	A1	9/2005	Hassan	2008/0174508	A1	7/2008	Iwai et al.
2005/0215204	A1	9/2005	Wallace	2008/0261544	A1	10/2008	Guillaume
2005/0227627	A1	10/2005	Cyr et al.	2008/0266190	A1	10/2008	Ohba et al.
2005/0227633	A1	10/2005	Dunko	2008/0268893	A1	10/2008	Lee et al.
2005/0259011	A1	11/2005	Vance	2008/0274706	A1	11/2008	Blin
2005/0260962	A1	11/2005	Nazrul et al.	2008/0280570	A1	11/2008	Blin
2005/0264455	A1	12/2005	Talvitie	2008/0285729	A1	11/2008	Glasgow et al.
2005/0280588	A1	12/2005	Fujikawa et al.	2008/0288028	A1	11/2008	Larson et al.
2005/0282503	A1	12/2005	Onno	2008/0294718	A1	11/2008	Okano
2006/0003537	A1	1/2006	Sinha	2008/0300027	A1	12/2008	Dou et al.
2006/0009165	A1	1/2006	Alles	2008/0305749	A1	12/2008	Ben-Bassat
2006/0022882	A1	2/2006	Gerder et al.	2008/0305750	A1	12/2008	Alon et al.
2006/0030277	A1	2/2006	Cyr et al.	2008/0309617	A1	12/2008	Kong et al.
2006/0077082	A1	4/2006	Shanks et al.	2009/0002077	A1	1/2009	Rohani et al.
2006/0084392	A1	4/2006	Marholev et al.	2009/0016124	A1	1/2009	Kim
2006/0099915	A1	5/2006	Laroia et al.	2009/0027286	A1	1/2009	Ohishi
2006/0099952	A1	5/2006	Prehofer et al.	2009/0039976	A1	2/2009	McKinzie, III
2006/0119511	A1	6/2006	Collinson et al.	2009/0051604	A1	2/2009	Zhang et al.
2006/0148415	A1	7/2006	Hamalainen et al.	2009/0051611	A1	2/2009	Shamblin et al.
2006/0160501	A1	7/2006	Mendolia	2009/0079656	A1	3/2009	Peyla et al.
2006/0183431	A1	8/2006	Chang et al.	2009/0082017	A1	3/2009	Chang et al.
2006/0183433	A1	8/2006	Mori et al.	2009/0088093	A1	4/2009	Nentwig et al.
2006/0183442	A1	8/2006	Chang et al.	2009/0109880	A1	4/2009	Kim et al.
2006/0195161	A1	8/2006	Li et al.	2009/0121963	A1	5/2009	Greene
2006/0205368	A1	9/2006	Bustamante	2009/0149136	A1	6/2009	Rofougaran
2006/0209767	A1	9/2006	Chae et al.	2009/0180403	A1	7/2009	Tudosoiu
2006/0223451	A1	10/2006	Posamentier	2009/0184879	A1	7/2009	Derneryd
2006/0252391	A1	11/2006	Poilasne et al.	2009/0196192	A1	8/2009	Lim et al.
2006/0281423	A1	12/2006	Caimi	2009/0215446	A1	8/2009	Hapsari et al.
				2009/0231220	A1	9/2009	Zhang et al.
				2009/0253385	A1	10/2009	Dent et al.
				2009/0264065	A1	10/2009	Song
				2009/0278685	A1	11/2009	Potyrailo

(56)

References Cited

U.S. PATENT DOCUMENTS

2009/0295651	A1	12/2009	Dou et al.
2009/0323572	A1	12/2009	Shi et al.
2009/0323582	A1	12/2009	Proctor et al.
2010/0041348	A1	2/2010	Wilcox et al.
2010/0053009	A1	3/2010	Rofougaran
2010/0060531	A1	3/2010	Rappaport
2010/0069011	A1	3/2010	Carrick et al.
2010/0073103	A1	3/2010	Spears et al.
2010/0085260	A1	4/2010	McKinzie
2010/0085884	A1	4/2010	Srinivisan et al.
2010/0105425	A1	4/2010	Asokan
2010/0107067	A1	4/2010	Vaisanen et al.
2010/0134215	A1	6/2010	Lee et al.
2010/0156552	A1	6/2010	McKinzie
2010/0164640	A1	7/2010	McKinzie
2010/0164641	A1	7/2010	McKinzie
2010/0201598	A1	8/2010	Lau et al.
2010/0214189	A1	8/2010	Kanazawa et al.
2010/0232474	A1	9/2010	Rofougaran
2010/0244576	A1	9/2010	Hillan et al.
2010/0277363	A1	11/2010	Kainulainen et al.
2010/0285836	A1	11/2010	Horihata et al.
2010/0302106	A1	12/2010	Knudsen et al.
2010/0304684	A1	12/2010	Duron et al.
2010/0304688	A1	12/2010	Knudsen
2010/0308933	A1	12/2010	See et al.
2011/0002080	A1	1/2011	Ranta
2011/0012790	A1	1/2011	Badaruzzaman
2011/0012792	A1	1/2011	Krenz
2011/0014879	A1	1/2011	Alberth et al.
2011/0014886	A1	1/2011	Manssen
2011/0019606	A1	1/2011	Umeda et al.
2011/0026415	A1	2/2011	Kamuf et al.
2011/0039504	A1	2/2011	Nguyen et al.
2011/0043298	A1	2/2011	McKinzie
2011/0043328	A1	2/2011	Bassali
2011/0053524	A1	3/2011	Manssen
2011/0063042	A1	3/2011	Mendolia
2011/0086600	A1	4/2011	Muhammad
2011/0086630	A1	4/2011	Manssen
2011/0102290	A1	5/2011	Milosavljevic
2011/0105023	A1	5/2011	Scheer et al.
2011/0116395	A1	5/2011	Tsuda et al.
2011/0116423	A1	5/2011	Rousu et al.
2011/0117863	A1	5/2011	Camp, Jr. et al.
2011/0117973	A1	5/2011	Asrani et al.
2011/0121079	A1	5/2011	Lawrence et al.
2011/0122040	A1	5/2011	Wakabayashi et al.
2011/0133994	A1	6/2011	Korva
2011/0140982	A1	6/2011	Ozden et al.
2011/0183628	A1	7/2011	Baker
2011/0183633	A1	7/2011	Ohba
2011/0195679	A1	8/2011	Lee et al.
2011/0227666	A1	9/2011	Manssen
2011/0237207	A1	9/2011	Bauder
2011/0249760	A1	10/2011	Chrisikos et al.
2011/0250852	A1	10/2011	Greene
2011/0254637	A1	10/2011	Manssen
2011/0254638	A1	10/2011	Manssen
2011/0256857	A1	10/2011	Chen et al.
2011/0281532	A1	11/2011	Shin et al.
2011/0285511	A1	11/2011	Maguire et al.
2011/0299438	A1	12/2011	Mikhemar
2011/0306310	A1	12/2011	Bai
2011/0309980	A1	12/2011	Ali et al.
2012/0039189	A1	2/2012	Suzuki et al.
2012/0051409	A1	3/2012	Brobston et al.
2012/0056689	A1	3/2012	Spears et al.
2012/0062431	A1	3/2012	Tikka et al.
2012/0075159	A1	3/2012	Chang
2012/0084537	A1	4/2012	Indukuru
2012/0094708	A1	4/2012	Park
2012/0099462	A1	4/2012	Yuda et al.
2012/0100802	A1	4/2012	Mohebbi
2012/0112851	A1	5/2012	Manssen
2012/0112852	A1	5/2012	Manssen et al.
2012/0112970	A1	5/2012	Caballero et al.
2012/0119843	A1	5/2012	du Toit et al.
2012/0119844	A1	5/2012	du Toit et al.
2012/0139810	A1	6/2012	Faraone et al.
2012/0154975	A1	6/2012	Oakes
2012/0214421	A1	8/2012	Hoirup
2012/0220243	A1	8/2012	Mendolia
2012/0243579	A1	9/2012	Premakanthan et al.
2012/0286586	A1	11/2012	Balm
2012/0293384	A1	11/2012	Knudsen et al.
2012/0295554	A1	11/2012	Greene
2012/0295555	A1	11/2012	Greene et al.
2012/0309332	A1	12/2012	Liao et al.
2013/0005277	A1	1/2013	Klomsdorf et al.
2013/0052967	A1	2/2013	Black et al.
2013/0056841	A1	3/2013	Hsieh et al.
2013/0076579	A1	3/2013	Zhang et al.
2013/0076580	A1	3/2013	Zhang et al.
2013/0106332	A1	5/2013	Williams et al.
2013/0122829	A1	5/2013	Hyvonen et al.
2013/0137384	A1	5/2013	Desclos et al.
2013/0154897	A1	6/2013	Sorensen et al.
2013/0182583	A1	7/2013	Siomina et al.
2013/0194054	A1	8/2013	Presti
2013/0215846	A1	8/2013	Yerrabommanahalli et al.
2013/0231155	A1	9/2013	Sheynman et al.
2013/0265912	A1	10/2013	Ikonen et al.
2013/0293425	A1	11/2013	Zhu et al.
2013/0315285	A1	11/2013	Black et al.
2014/0002323	A1	1/2014	Ali et al.
2014/0009360	A1	1/2014	Ikonen et al.
2014/0128032	A1	5/2014	Muthukumar
2014/0162572	A1	6/2014	Hirabayashi
2014/0210686	A1	7/2014	Ali et al.
2014/0287698	A1	9/2014	Ali et al.
2014/0366927	A1	12/2014	Lavrova et al.
2016/0173172	A1	6/2016	Greene
2016/0241276	A1	8/2016	Zhu
2016/0269055	A1	9/2016	Greene et al.
2016/0277129	A1	9/2016	Manssen
2016/0322991	A1	11/2016	McKinzie
2016/0336916	A1	11/2016	Du Toit et al.
2016/0352408	A1	12/2016	Greene
2016/0373146	A1	12/2016	Manssen et al.
2017/0011858	A1	1/2017	Oakes et al.
2017/0085244	A1	3/2017	Manssen et al.
2017/0197180	A1	7/2017	Wei
2017/0264322	A1	9/2017	Greene et al.
2017/0264335	A1	9/2017	Hoirup et al.
2017/0294712	A1	10/2017	Greene et al.
2017/0294891	A1	10/2017	McKinzie, III
2017/0353956	A1	12/2017	Carsten
2017/0373661	A1	12/2017	Manssen et al.
2018/0083657	A1	3/2018	Manssen et al.
2018/0109235	A1	4/2018	McKinzie et al.
2018/0198482	A1	7/2018	Hoirup et al.
2018/0262257	A1	9/2018	Greene

FOREIGN PATENT DOCUMENTS

CN	201765685	U	3/2011
CN	105703797		6/2016
CN	105703797	A	6/2016
DE	19614655		10/1997
DE	10258805	B4	3/2005
DE	102008050743		4/2010
DE	102009018648	A1	10/2010
EM	0909024		4/1999
EP	0685936		6/1995
EP	0909024		4/1999
EP	1079296		2/2001
EP	1137192		9/2001
EP	1298810		4/2006
EP	20070197180		8/2007
EP	2214085	A2	8/2010
EP	2328233		6/2011
EP	2388925	A1	11/2011
EP	2424119	A1	2/2012

(56)

References Cited

FOREIGN PATENT DOCUMENTS

EP	2638640	A4	7/2014
EP	3131157		2/2017
JP	03-276901		3/1990
JP	02-077580		9/1991
JP	9321526		12/1997
JP	10209722		8/1998
JP	2000124066		4/2000
JP	2005-130441		5/2005
KR	100645526		11/2006
KR	10-0740177		7/2007
WO	2001/071846		9/2001
WO	2006/031170		3/2006
WO	2008/030165		3/2008
WO	2008133854	A1	11/2008
WO	2009/064968		5/2009
WO	2009/108391	A1	9/2009
WO	2009/155966		12/2009
WO	2009155966	A1	12/2009
WO	2010028521	A1	3/2010
WO	2010121914	A1	10/2010
WO	2011/044592		4/2011
WO	2011/084716		7/2011
WO	2011084716	A1	7/2011
WO	2011102143	A1	8/2011
WO	2011/133657		10/2011
WO	WO-2011028453		10/2011
WO	2012/067622		5/2012
WO	2012067622	A1	5/2012
WO	2012/085932		6/2012
WO	2012085932	A2	6/2012
WO	2012112831	A1	8/2012

OTHER PUBLICATIONS

Communication pursuant to Article 94(3) EPC, EPO application No. 16151299.1, dated Jun. 22, 2018.

Canadian Office Action, Application No. 2,821,173, dated Oct. 17, 2016.

Extended European Search Report for 12749235.3 dated Jun. 8, 2017.

Canadian Office Action dated Feb. 8, 2018, application No. 2826573, 4 pages.

Office Action dated Nov. 7, 2018, Canadian Patent Application 2,826,573, 4 pages.

Communication pursuant to Article 94(3) EPC, Application No. 10822849.5, dated Oct. 11, 2017, 5 pages.

“China International Intellectual Property Administration”, First Office Action for CN Application No. 201510941292.3, dated Oct. 29, 2018, 6 pages.

“Communication pursuant to Article 94(3) EPC”, EP Application Serial No. 12750926.3, dated Mar. 16, 2018, 5 pages.

“European Search Report”, 16151299.1 search report, dated 2016.

“Extended European Search Report”, EP Application No. 16155235.1, dated May 3, 2016.

“Office Action Received in China Patent Application 201080045689.X”, dated Mar. 4, 2016, 6 pages.

“Search Report”, ROC (Taiwan) Patent Application No. 101117467, English Translation, dated Apr. 12, 2016, 1 page.

Canadian IPO, “Office Action dated Mar. 10, 2017”, dated Mar. 10, 2017, 1-3.

Eiji, N. , “High-Frequency Circuit and Its Manufacture”, Patent Abstracts of Japan, vol. 1998, No. 13, Nov. 30, 1998 & JP 10 209722 A (Seiko Epson Corp), Aug. 7, 1998.

EPO, , “Extended European Search Report”, EP 16188956.3, dated 2017, 1-9.

EPO, , “Extended European Search Report, EP16188956.3,”, dated Jan. 9, 2017, 1-9.

European Patent Office, , “EP Office Action dated Feb. 28, 2019”, for EP Application 11772625.7, Feb. 28, 2019, 11 pages.

European Patent Office, , “Office Action dated Nov. 28, 2018”, EP Application No. 15198585.0, Nov. 28, 2018, 4 pages.

Huang, Libo et al., “Theoretical and experimental investigation of adaptive antenna impedance matching for multiband mobile phone applications”, IEEE, Sep. 7, 2005, 13-17.

Hyun, S. , “Effects of strain on the dielectric properties of tunable dielectric SrTiO₃ thin films”, Applied Physics Letters, vol. 79, No. 2, Jul. 9, 2001.

India, Patent O. , “Examination Report”, for Application No. 9844/DELNP/2013, dated Apr. 25, 2018, 5 pages.

Intellectual Property India, “First Examination Report”, for Application No. 3160/CHE/2013 dated Jun. 5, 2018, Jun. 5, 2018, 5 pages.

Katsuya, K. , “Hybrid Integrated Circuit Device”, Patent Abstracts of Japan, Publication No. 03-276901, Date of publication of application: Sep. 12, 1991.

Nowrouzian, B. , “A necessary and sufficient condition for the BIBO stability of general-order bode-type variable-amplitude wave-digital equalizers,” ICME '03. Proc., USA, 2003, pp. 373-376. (Year: 2003).

Patent Cooperation Treaty, , “International Search Report and Written Opinion”, International Application No. PCT/US2010/046241, dated Mar. 2, 2011.

Patent Cooperation Treaty, , “International Search Report and Written Opinion”, International Application No. PCT/US2010/056413, dated Jul. 27, 2011.

Patent Cooperation Treaty, , “International Search Report and Written Opinion”, dated Nov. 16, 2011, International Application No. PCT/US/2011/038543.

Patent Cooperation Treaty, , “International Search Report and Written Opinion”, PCT Application No. PCT/US08/005085, dated Jul. 2, 2008.

Payandehjoo, Kasra et al., “Investigation of Parasitic Elements for Coupling Reduction in MultiAntenna Hand-Set Devices”, Published online Jan. 22, 2013 in Wiley Online Library (wileyonlinelibrary.com).

Pervez, N.K. , “High Tunability barium strontium titanate thin films for RF circuit applications”, Applied Physics Letters, vol. 85, No. 19, Nov. 8, 2004.

Petit, Laurent , “MEMS-Switched Parasitic-Antenna Array for Radiation Pattern Diversity”, IEEE Transactions on Antennas and Propagation, vol. 54, No. 9, Sep. 2006, 2624-2631.

Qiao, et al., “Antenna Impedance Mismatch Measurement and Correction for Adaptive COMA Transceivers”, IEEE, Jan. 2005.

Stemmer, Susanne , “Low-loss tunable capacitors fabricated directly on gold bottom electrodes”, Applied Physics Letters 88, 112905, Mar. 15, 2006.

Taylor, T.R. , “Impact of thermal strain on the dielectric constant of sputtered barium strontium titanate thin films”, Applied Physics Letters, vol. 80, No. 11, Mar. 18, 2002.

Xu, Hongtao , “Tunable Microwave Integrated Circuits using BST Thin Film Capacitors with Device”, Integrated Ferroelectrics, Department of Electrical Engineering and Computer Engineering, University of California, 2005, Apr. 2005.

Zuo, S. , “Eigenmode Decoupling for Mimo Loop-Antenna Based on 180 Coupler”, Progress in Electromagnetics Research Letters, vol. 26, Aug. 2011, 11-20.

Bezooijen, A. et al., “A GSM/EDGE/WCDMA Adaptive Series-LC Matching Network Using RF-MEMS Switches”, IEEE Journal of Solid-State Circuits, vol. 43, No. 10, Oct. 2008, 2259-2268.

Du Toit, , “Tunable Microwave Devices With Auto Adjusting Matching Circuit”, U.S. Appl. No. 13/302,617, filed Nov. 22, 2011.

Du Toit, , “Tunable Microwave Devices With Auto-Adjusting Matching Circuit”, U.S. Appl. No. 13/302,659, filed Nov. 22, 2011.

Greene, , “Method and Apparatus for Tuning a Communication Device”, U.S. Appl. No. 13/108,463, filed May 16, 2011.

Greene, , “Method and Apparatus for Tuning a Communication Device”, U.S. Appl. No. 13/108,589, filed May 16, 2011.

Hoirup, , “Method and Apparatus for Radio Antenna Frequency Tuning”, U.S. Appl. No. 13/030,177, filed Feb. 18, 2011.

Hyun, S. , “Effects of strain on the dielectric properties of tunable dielectric SrTiO₃ thin films”, Applied Physics Letters, 2004 American Institute of Physics.

(56)

References Cited

OTHER PUBLICATIONS

Ida, I. et al., "An Adaptive Impedance Matching System and Its Application to Mobile Antennas", TENCON 2004, IEEE Region 10 Conference, See Abstract at p. 544, Nov. 21-24, 2004, 543-547.

Manssen, , "Method and Apparatus for Managing Interference in a Communication Device", U.S. Appl. No. 61/326,206, filed Apr. 20, 2010.

Manssen, , "Method and Apparatus for Tuning Antennas in a Communication Device", U.S. Appl. No. 12/941,972, filed Nov. 8, 2010.

Manssen, , "Method and Apparatus for Tuning Antennas in a Communication Device", U.S. Appl. No. 13/005,122, filed Jan. 12, 2011.

McKinzie, , "Adaptive Impedance Matching Module (AIMM) Control Architectures", U.S. Appl. No. 13/293,544, filed Nov. 10, 2011.

McKinzie, , "Adaptive Impedance Matching Module (AIMM) Control Architectures", U.S. Appl. No. 13/293,550, filed Nov. 10, 2011.

McKinzie, , "Method and Apparatus for Adaptive Impedance Matching", U.S. Appl. No. 13/217,748, filed Aug. 25, 2011.

Mendolia, "Method and Apparatus for Tuning a Communication Device", U.S. Appl. No. 13/035,417, filed Feb. 25, 2011.

Paratek Microwave, Inc., , "Method and Apparatus for Tuning Antennas in a Communication Device", International Application No. PCT/US11/59620, filed Nov. 7, 2011.

Pervez, N.K. , "High Tunability barium strontium titanate thin films for RF circuit applications", Applied Physics Letters, 2004 American Institute of Physics.

Petit, Laurent , "MEMS-Switched Parasitic-Antenna Array for Radiation Pattern Diversity", IEEE Transactions on Antennas and Propagation, vol. 54, No. 9, Sep. 2009, 2624-2631.

Qiao, et al., "Antenna Impedance Mismatch Measurement and Correction for Adaptive COMA Transceivers", IEEE, 2005.

Qiao, et al., "Measurement of Antenna Load Impedance for Power Amplifiers", The Department of Electrical and Computer Engineering, University of California, San Diego, Sep. 13, 2004.

Spears, , "Methods for Tuning an Adaptive Impedance Matching Network With a Look-Up Table", U.S. Appl. No. 13/297,951, filed Nov. 16, 2011.

Stemmer, Susanne , "Low-loss tunable capacitors fabricated directly on gold bottom electrodes", University of California Postprints 2006.

Taylor, T.R. , "Impact of thermal strain on the dielectric constant of sputtered barium strontium titanate thin films", Applied Physics Letters, 2002 American Institute of Physics.

Tombak, Ali , "Tunable Barium Strontium Titanate Thin Film Capacitors for RF and Microwave Applications", IEEE Microwave and Wireless Components Letters, vol. 12, Jan. 2002.

Xu, Hongtao , "Tunable Microwave Integrated Circuits using BST Thin Film Capacitors with Device", Integrated Ferroelectrics, Department of Electrical Engineering and Computer Engineering, University of California, 2005.

Zuo, S. , "Eigenmode Decoupling for Mimo Loop-Antenna Based on 180 Coupler", Progress in Electromagnetics Research Letters, vol. 26, 2011, 11-20.

* cited by examiner

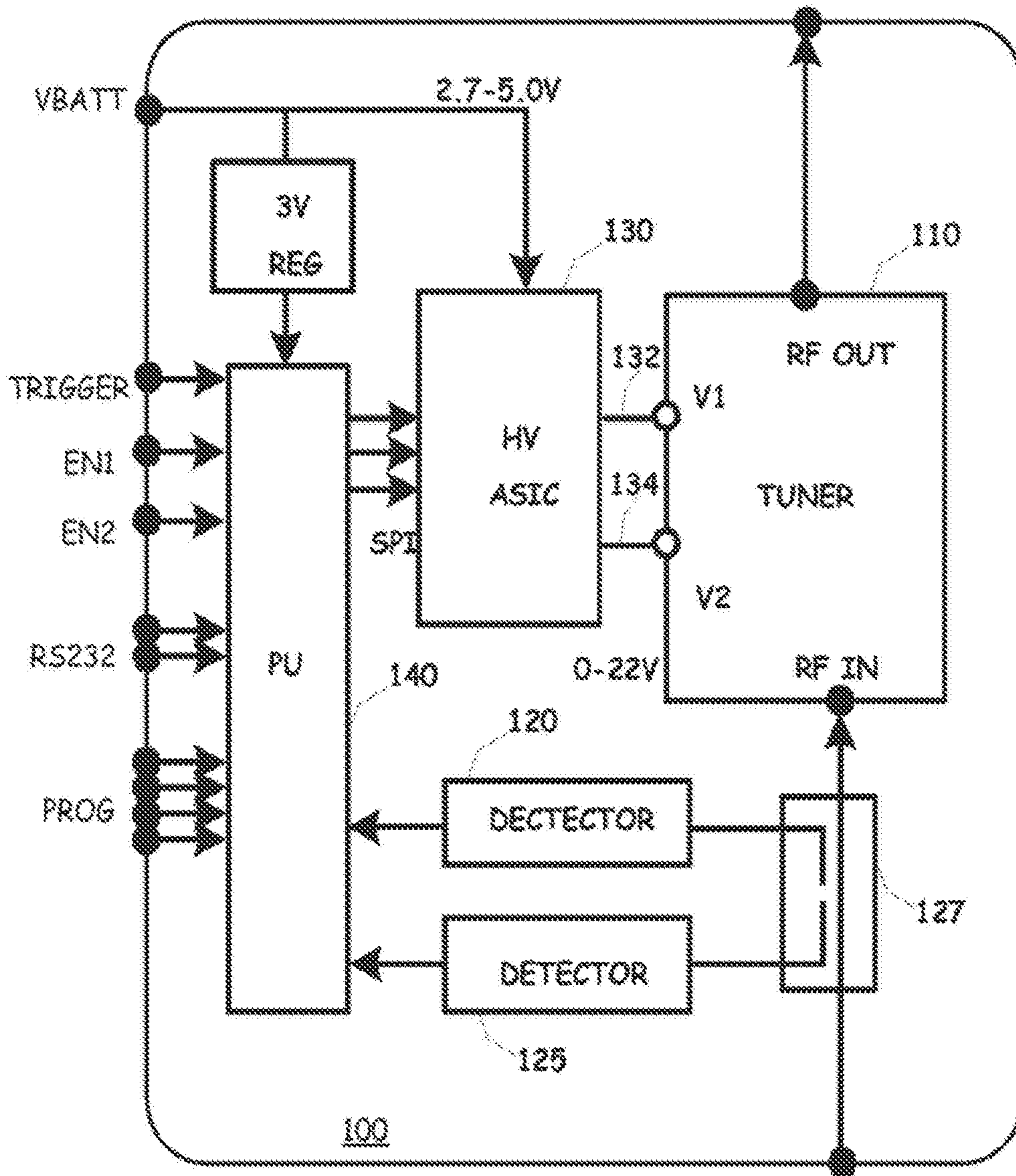

FIG. 1

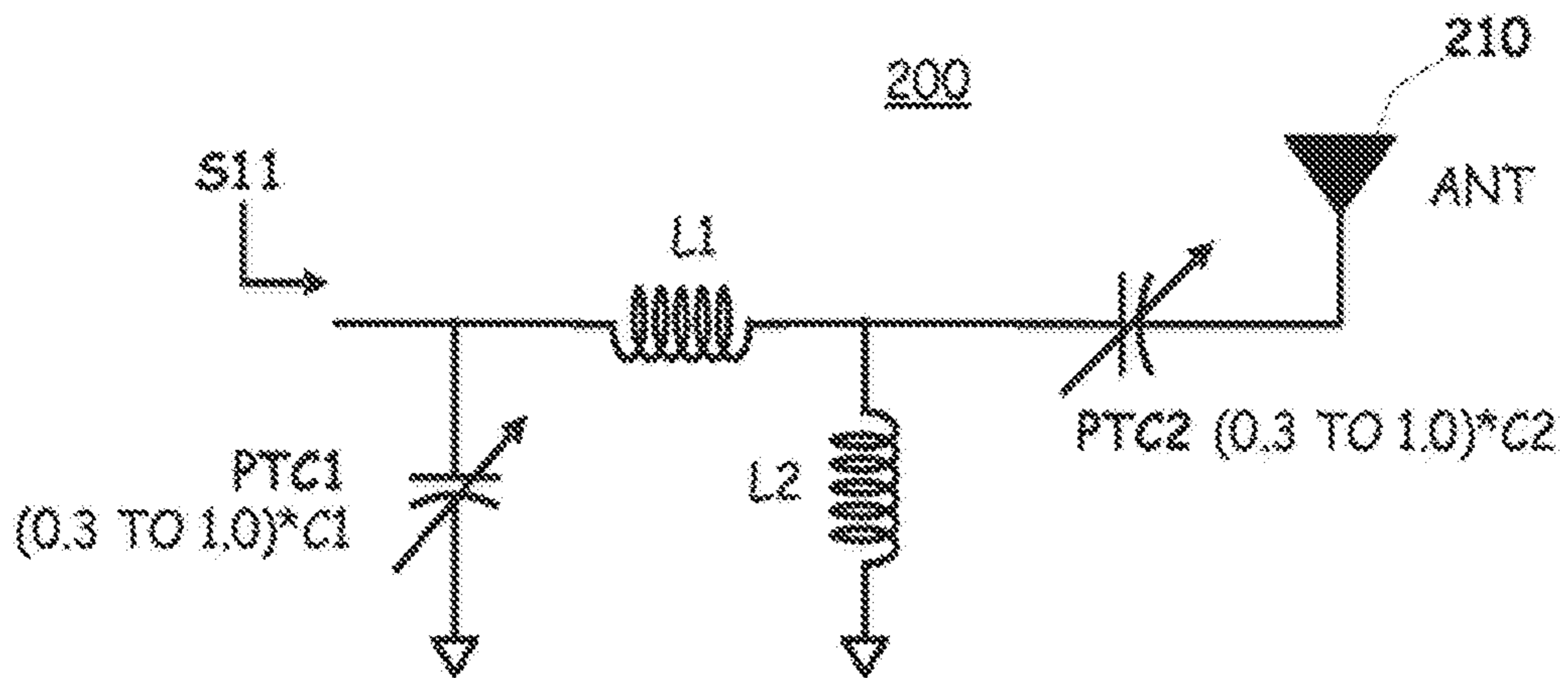

FIG. 2

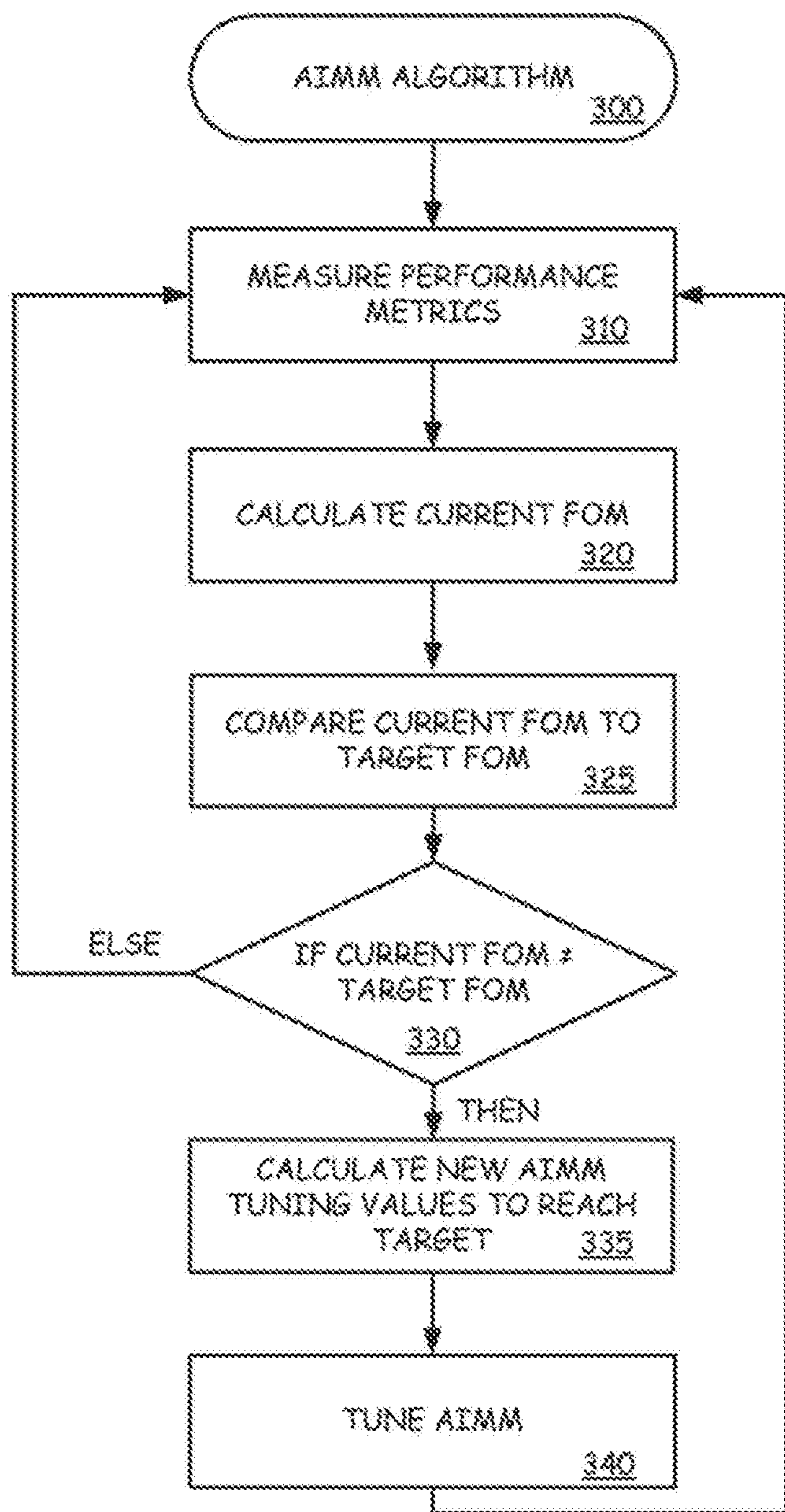

FIG. 3

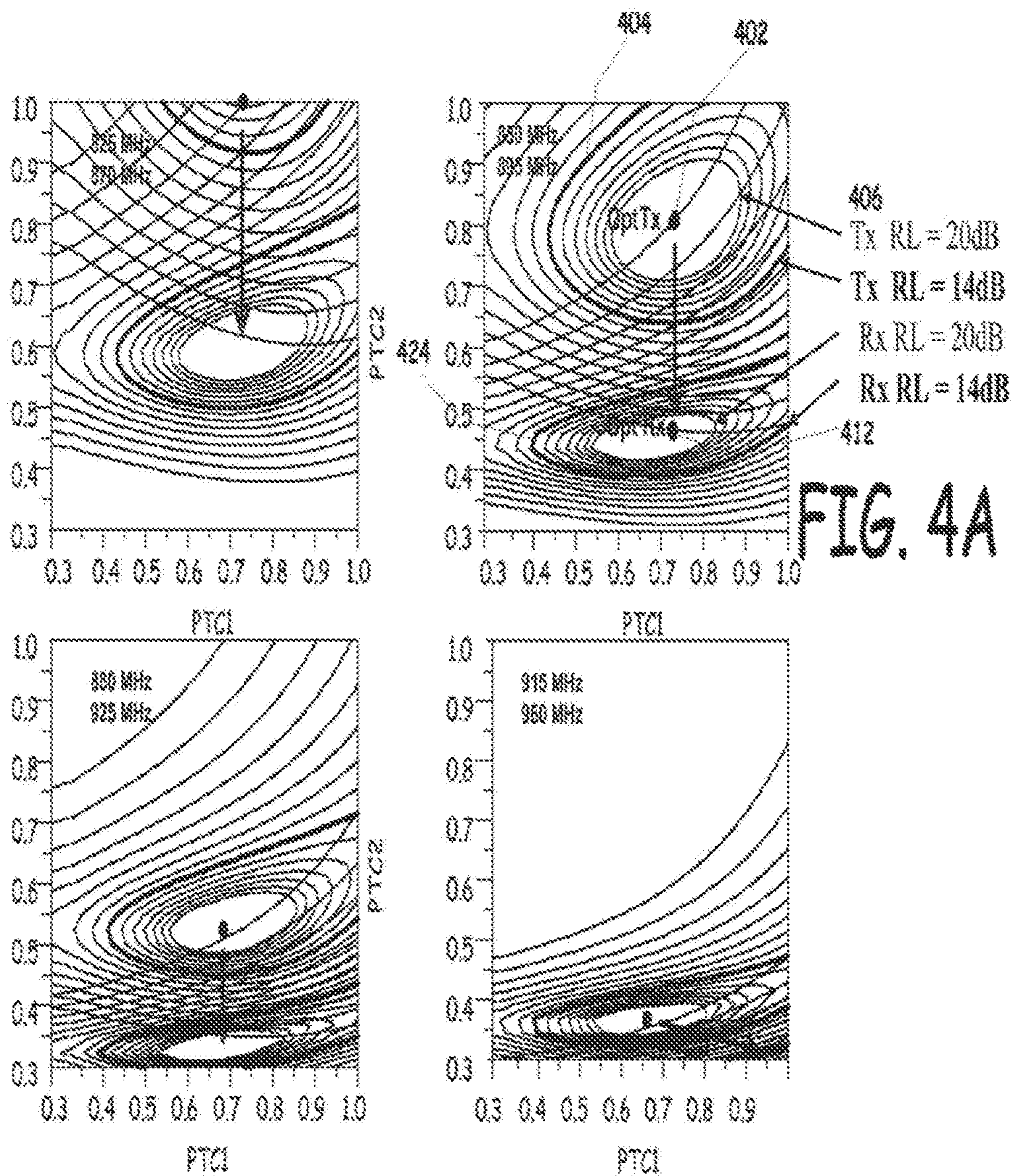

FIG. 4A

FIG. 4

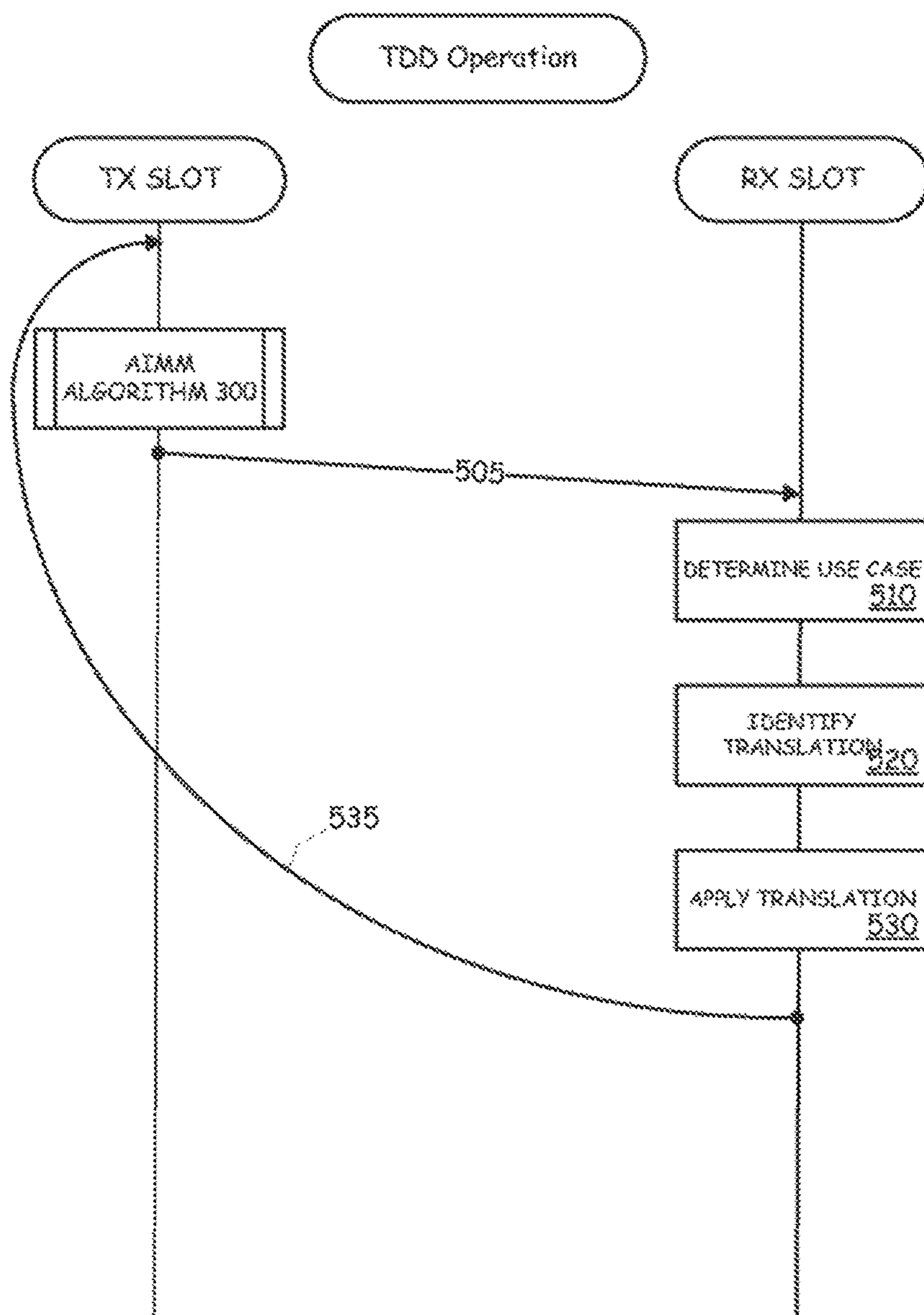

FIG. 5

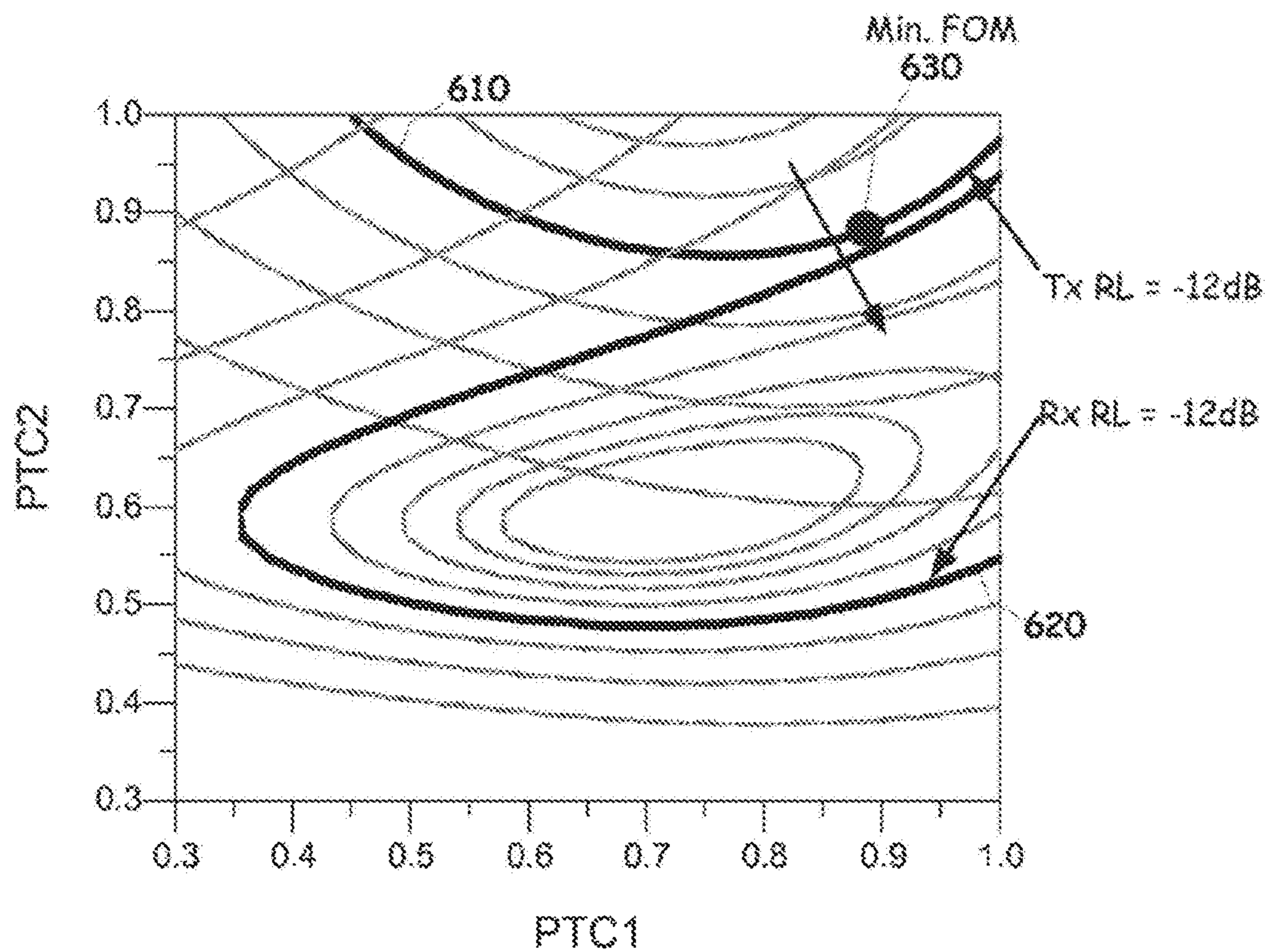

FIG. 6

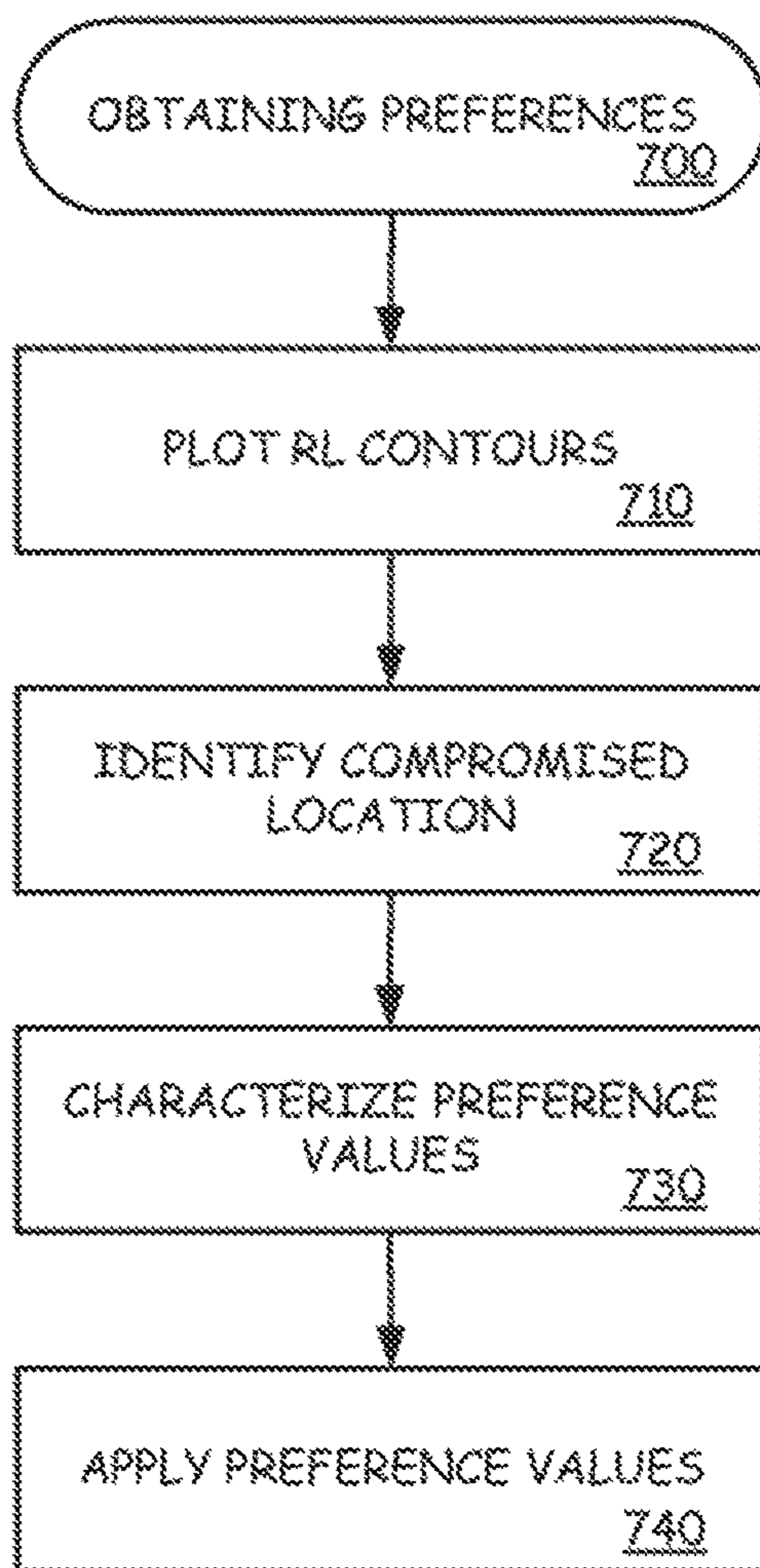

FIG. 7

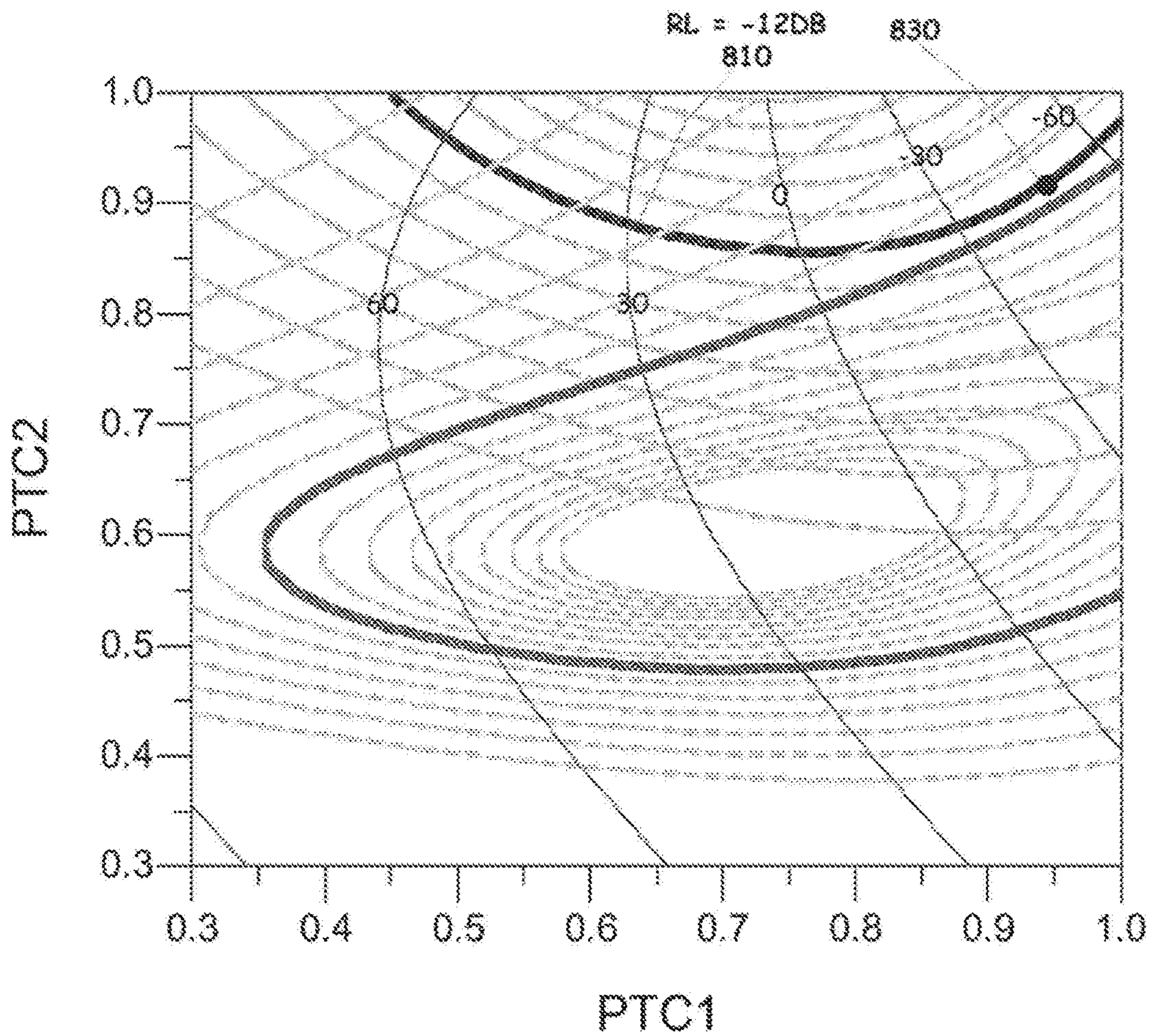

FIG. 8

**TUNING MATCHING CIRCUITS FOR
TRANSMITTER AND RECEIVER BANDS AS
A FUNCTION OF THE TRANSMITTER
METRICS**

Matter enclosed in heavy brackets [] appears in the original patent but forms no part of this reissue specification; matter printed in italics indicates the additions made by reissue; a claim printed with strikethrough indicates that the claim was canceled, disclaimed, or held invalid by a prior post-patent action or proceeding.

CROSS-REFERENCE TO RELATED
APPLICATIONS

Notice: More than one reissue application has been filed for the reissue of U.S. Pat. No. 8,798,555. The Reissue applications are application Ser. No. 14/716,014, and the present application filed herewith. This application is a continuation [of co-pending] reissue application of U.S. patent application Ser. No. 14/716,014, filed May 19, 2015, which is an application for reissue of U.S. Pat. No. 8,798,555, issued on Aug. 5, 2014, from U.S. patent application Ser. No. 13/693,388, which is a continuation of U.S. patent application Ser. No. 13/168,529, filed on Jun. 24, 2011, now U.S. Pat. No. 8,428,523, which is a continuation of U.S. patent application Ser. No. 11/940,309 filed on Nov. 14, 2007, now U.S. Pat. No. 7,991,363, the disclosures of all of which are hereby incorporated by reference in their entirety.

FILED OF THE DISCLOSURE

The present invention is directed towards impedance matching circuits and more particularly, adaptive impedance matching circuits to improve transceiver operation in a variety of scenarios.

BACKGROUND OF THE INVENTION

As more technology and features are incorporated into small packages, engineering teams must get more and more creative, especially in the face of lagging miniaturization of parts and components. One of the areas that engineers focus on is multipurpose circuitry or, circuitry that meets a variety of functions. A good example of this focus is with regards to antenna matching circuits within cellular telephone devices.

Cellular telephone devices have migrated from single cellular technology supporting devices to multi-cellular technology devices integrating a variety of other consumer features such as MP3 players, color displays, games, etc. Thus, not only are the cellular telephone devices required to communicate at a variety of frequencies, they are also subjected to a large variety of use conditions. All of these factors can result in a need for different impedance matching circuits for the antenna. However, by utilizing tunable components, a single matching circuit can be used under a variety of circumstances. Tunable matching circuits generally operate to adjust the impedance match with an antenna over a frequency range to maximize the output power. However, difficulties arise when attempting to tune the matching circuit for signal reception. What is needed in the art is an adaptive impedance matching module that can operate to optimize performance of both the transmitter and the receiver under a variety of circumstances. Further, what is needed is an adaptive impedance matching module that

optimizes performance of the transceiver based on optimizing the operation in view of a figure of merit.

BRIEF SUMMARY OF THE INVENTION

In general, embodiments of the invention include a tunable matching circuit and an algorithm for adjusting the same. More particularly, the tuning circuit is adjusted primarily based on transmitter oriented metrics and is then applied to attain a desired tuning for both transmitter and receiver operation. In a time division multiplexed (TDM) system in which the transmitter and the receiver operate at different frequencies but are only keyed in their respective time slots (i.e. transmit time slot and receive time slot), this is accomplished by identifying an optimal tuning for the transmitter and then adding an empirically derived adjustment to the tuning circuit in receive mode. In a frequency division multiplexed (FDM) system in which the transmitter and receiver operate simultaneously and at different frequencies, this is accomplished by identifying a target operation for the transmitter, and then adjusting the tuning circuit first to the target value for the transmitter and then adjusting the values to approach a compromised value proximate to an equal or desired target value for the receiver.

An exemplary embodiment of the present invention provides a method for controlling a matching circuit for interfacing an antenna with a transceiver. The matching circuit includes one or more tunable components. The tuning of the matching circuit is based on a figure of merit that incorporates one or more operation metrics. One aspect of the present invention is that the operation metrics can be transmitter based but still provide desired adjustment results for receiver operation. The operation metric(s) is monitored and measured and then compared to the figure of merit. If the desired operation is not attained, the variable component(s) of the matching circuit is adjusted using one or more of a variety of techniques to attain the figure of merit. This process is performed to maintain operation at the figure of merit.

In one embodiment of the invention more particularly suited for TDM systems, an offset, scaling factor, translation or other change or modification is applied to the adjustments of the variable components when switching from the transmit mode to the receive mode. This translation is a function of the values obtained while adjusting during the transmit time slot. The translation is then removed upon return to the transmitter mode and the adjustment process is resumed.

In another embodiment of the invention particularly suited for FDM systems, the figure of merit not only incorporates the transmit metrics, but also incorporates an element to attain a compromise between optimal transmitter and optimal receiver operation. This is accomplished by identifying a target operation goal, such as a desired transmitter and receiver reflection loss and then identifying an operational setting that is a close compromise between the two. This embodiment thus incorporates not only transmitter metrics but also tuning circuit settings or preferences into the algorithm. The tuning preferences can be empirically identified to ensure the desired operation.

These and other aspects, features and embodiments of the present invention will be more appreciated upon review of the figures and the detailed description.

BRIEF DESCRIPTION OF THE SEVERAL
VIEWS OF THE DRAWING

FIG. 1 is a block diagram illustrating an exemplary environment for deployment of one or more embodiments of the present invention.

FIG. 2 is a circuit diagram illustrating further details of an exemplary matching circuit that could be included in the AIMM in an exemplary embodiment of the present invention.

FIG. 3 is a flow diagram illustrating the general steps taken in an exemplary embodiment of the present invention.

FIG. 4 and FIG. 4A are a plots of the transmitter reflection losses for four operating frequencies.

FIG. 5 is a flow diagram illustrating the steps involved in an exemplary embodiment of the present invention operating in a TDM environment.

FIG. 6 is a return loss contour diagram in the PTC plane for a particular frequency (i.e., 825 MHz/870 MHz operation).

FIG. 7 is a flow diagram illustrating the steps involved in an exemplary embodiment of the present invention in obtaining the preference values for PTC1 and PTC2.

FIG. 8 is a contour plot showing the magnitude and the phase of the reflection coefficient.

DETAILED DESCRIPTION OF THE INVENTION

The present invention, as well as features and aspects thereof, is directed towards providing an impedance matching circuit, module or component that in response to sensing the matching condition by monitoring one or more metrics or parameters of the transmitter, can be adjusted to optimize the match.

More specifically, embodiments of the present invention include adaptive impedance matching circuits, modules, IC's etc., that operate to sense the matching condition of the transmit signal or other transmitter related metric and then optimizes the matching characteristics by adjusting the values of one or more tunable devices in view of attaining or reaching a figure of merit. The figure of merit can be based on a variety of elements, such as the input return loss, output power, current drain, linearity metrics, as well as others. In the embodiments of the present invention that are presented herein, the figure of merit is typically described or defined as being based on the input return loss. However, it is to be understood that this is just a non-limiting example of the present invention, and although it may in and of itself be considered as novel, other transmitter, or non-receiver, related metrics may be incorporated into the figure of merit in addition to or in lieu of the input return loss or reflection loss.

In an exemplary embodiment, an adaptive impedance matching module (AIMM) detects transmitter related metrics and optimizes the matching circuit keyed on the transmit signal. A benefit associated with focusing on the transmit signal, as well as other transmitter metrics, is that the transmit signal is higher in power than the receive signal and thus, is easier to detect. However, it will be appreciated by those skilled in the art that it is desirable to improve the matching conditions for both the transmit signal and the receive signal. Advantageously, the present invention operates to optimize a figure of merit that achieves a desired operation of both signals even though the matching adjustments performed by the AIMM are only based on sensing the transmitter related metrics.

One embodiment of the invention is particularly well suited for operating in a time division multiplexed (TDM) system. In a TDM system, the radio transmits and receives in different time slots. Typically, the transmitter and receiver also operate on different frequencies; however, it will be appreciated that some systems utilize the same frequency for

transmission and reception. Nonetheless, in a TDM system, the transmitter and receiver are not active at the same time. In this environment, the AIMM can be adjusted to optimal settings for the transmitter during a transmit time slot and then the AIMM can be adjusted to optimal setting for the receiver during the receive time slot. As such, the AIMM tuner can be set differently during transmit and receive time slots. During the transmit time slot, an adjustment algorithm is applied to determine the appropriate settings of the AIMM to optimize the match or attain a figure of merit that results in achieving or approaching a desired level of operation. Because any frequency offset between the transmit signal and the receive signal is known, an adjustment or modification of the setting of the AIMM in the form of a translation or some other function is applied to the AIMM during the receive time slot. The adjustment improves the matching characteristics at the receiver frequency based on knowledge determined during the transmit time slot and the general operation of the receiver. During the next transmit time slot, the translation is removed from the AIMM and the adjustment algorithm regains control of the AIMM. Upon returning to the receive time slot, the modification can be reapplied or, if the settings during the transmit time slot have been changed, then the new settings can be modified for the subsequent receive time slot.

The adjustment applied to the AIMM during the receive time slot can be obtained in a variety of manners. For instance, in one embodiment the adjustment may be a translation derived empirically by characterizing the tuner at the transmitter and receiver frequencies and then deriving a mapping function to describe the translation. Alternatively, the translation may be derived by using the known (or theoretical) S-parameters of the tuner network.

Another embodiment of the present invention is particularly suited for a Frequency Division Multiplexed (FDM) system. In an FDM system, the radio transmits and receives at the same time but at different frequencies. Unlike the embodiment suited for a TDM application, the FDM application requires the AIMM to use the same tuning condition for both transmitter and receiver operation. In this embodiment, the tuner is adjusted to provide a desired compromise between matching at the transmit frequency and matching at the receive frequency. It will be appreciated that this compromise could be attained by simply defining a figure of merit that incorporates both a transmitter metric and a receiver metric. However, as previously mentioned, the receive signal is typically lower than the transmit signal and as such, it may be difficult to accurately sense and use as a metric.

Thus, in this embodiment, non-receiver related metrics are used to find a desired compromised state for tuning the AIMM. It will be appreciated that the desired compromised state can vary based on embodiment and operational requirements. For instance, in some embodiments, transmission of data may be more important than reception and as such, preference may be given to optimizing the transmitter. Such a situation may exist in an emergency radio system that is used by people in the field and that need to report back to a central location, but are not necessarily dependent upon information from that central location. In other embodiments, the reception of data may be more important than the transmission. For instance, the reception of weather related information as an emergency warning system. In such an embodiment, preference may be given to optimizing the receiver. Yet in other embodiments, both the reception and transmission of data may be equally important and as such, a setting that gives a compromised performance or attempts

5

to equalize the performance of both the transmitter and receiver is desired. Such an embodiment is typical of cellular telephone operation.

The FDM suitable embodiments of the present invention operate to obtain a desired level of operation based on one or more transmitter related metrics, and also incorporate known characteristics about the tuning circuits to achieve the desired operating state. The desired operating state typically reflects a state of operation that is a compromise from the optimal states for the transmitter and receiver. For instance, one embodiment of the present invention may include the tuning states of the tunable devices in the matching circuit within a transmit signal based figure of merit. Advantageously, this aspect of the present invention enables improved performance in the receive band without having to take a receiver measurement.

Another embodiment of the invention deployable within an FDM environment is to tune the matching circuit to a figure of merit that is based on a vector measurement of the transmitter reflection coefficient. In this embodiment, the phase information in the vector measurement is incorporated into the figure of merit and the optimal compromise between the transmitter and receiver operation occurs at a particular phase of the transmitter reflection coefficient.

Now turning to the figures, the various embodiments, features, aspects and advantages of the present invention are presented in more detail.

FIG. 1 is a block diagram illustrating an exemplary environment for deployment of one or more embodiments of the present invention. The illustrated embodiment includes an adaptive impedance matching module (AIMM) 100, however, it should be appreciated that the invention can be incorporated into embodiments that utilize discrete components, integrated circuits, a combination of software, firmware and hardware, or the like, and that the embodiment presented as a module is a non-limiting example. Further, although the present invention is described within the context of an AIMM, it will be appreciated that various aspects, features and embodiments equally apply to other configurations. The AIMM 100 includes a tuner 110 that includes a matching circuit with one or more tunable elements or components. An exemplary embodiment of a tuner includes tunable capacitances and more specifically, two tunable capacitances, but it will be appreciated that the present invention can be applied to a wide variety of tunable impedance matching circuits. Operating in conjunction with sensor 127, a first detector 120 is used to detect the forward transmit power and a second detector 125 is used to detect the reflected transmit power. These values are measured in order to determine the transmitter return loss (i.e., $TxRL=20 \text{ Log}|S11|$) where S11 is known by those skilled in the art to be the ratio between the reflected and incident power on port 1. The environment may further include a high-voltage ASIC (HV-ASIC) 130 containing a DC/DC converter and at least two DACs to generate the high voltage bias signals 132 and 134 required to control the tunable components. A micro-controller, microprocessor or other processing unit (PU) 140 receives output signals from the forward detector 120 and the reflected detector 125 and can calculate the reflected loss of the transmitted signal and thus, characterize the impedance matching of the circuit. Not illustrated, the PU 140 also interfaces or includes one or more memory elements including, but not limited to various forms of volatile and non-volatile memory. For instance, the PU may periodically write values to memory and read values from memory, such as settings for the variable components in the AIMM.

6

FIG. 2 is a circuit diagram illustrating further details of an exemplary matching circuit 200 that could be included in the AIMM 100 for an exemplary embodiment of the present invention. The illustrated matching circuit 200 includes a first tunable capacitance PTC1, a first impedance L1, a second impedance L2 and a second tunable capacitance PTC2 where PTC is a Paratek Tunable Capacitor. The first tunable capacitance PTC1 is coupled to ground on one end and to the output of a transceiver on the other end. The node of PTC1 that is coupled to the transceiver is also connected to a first end of the first impedance L1. The second impedance L2 is connected between the second end of the first impedance L1 and ground. The second end of the first impedance L1 is also coupled to a first end of the second tunable capacitance PTC2. The second end of the second tunable capacitance PTC2 is then coupled to an antenna 210. The tunable capacitances can be tuned over a range such as 0.3 to 1 times a nominal value C. For instance, if the nominal value of the tunable capacitance is 5 pF, the tunable range would be from 1.5 to 5 pF. In an exemplary embodiment of the present invention, PTC1 has a nominal capacitance of 5 pf and is tunable over the 0.3 to 1 times range, the first impedance L1 as a value of 3.1 nH, and the second impedance L2 has a value of 2.4 nH and the second tunable capacitance PTC2 has a nominal value of 20 pF and can be tuned over a range of 0.3 to 1 times the nominal value. It will be appreciated that the tunable capacitances in the illustrated embodiment could be tuned or adjusted over their ranges in an effort to optimize the matching characteristics of the AIMM under various operating conditions. Thus, under various use conditions, operating environments and at various frequencies of operation, the tunable capacitances can be adjusted to optimize performance or attain a desired level of performance.

FIG. 3 is a flow diagram illustrating the general steps taken in an exemplary embodiment of the present invention. The basic flow of the algorithm 300 initially includes measuring the performance parameters or metrics 310 used as feedback pertaining to the performance of the AIMM or the impedance match between a transceiver and an antenna. The performance metrics utilized may vary over embodiments of the present invention, over various usage scenarios, over technology being utilized (i.e. FDM, TDM, etc.), based on system settings and/or carrier requirements, etc. For instance, in an exemplary embodiment of the present invention, the performance metrics include one or more of the following transmitter related metrics: the transmitter return loss, output power, current drain, and transmitter linearity.

Next, a current figure of merit (FOM) is calculated 320. The current FOM is based on the one or more performance metrics, as well as other criteria. The current FOM is then compared to a target FOM 325. The target FOM is the optimal or desired performance requirements or objective for the system. As such, the target FOM can be defined by a weighted combination of any measurable or predictable metrics. For instance, if it is desired to maximize the efficiency of the transmitter, the target FOM can be defined to result in tuning the matching network accordingly. Thus, depending on the goal or objective, the target FOM can be defined to tune the matching network to achieve particular goals or objectives. As a non-limiting example, the objectives may focus on total radiated power (TRP), total isotropic sensitivity (TIS), efficiency and linearity. Furthermore, the target FOM may be significantly different for a TDM system and an FDM system. It should be understood that the target FOM may be calculated or selected on the fly based on various operating conditions, prior measurements, and

modes of operation or, the target FOM could be determined at design time and hard-coded into the AIMM 100.

If it is determined that the current FOM is not equal to the target FOM, or at least within a threshold value of the target FOM 330, new tuning values for the AIMM 100 are calculated or selected 335. However, if the current FOM is equal to or within the defined threshold, then processing continues by once again measuring the performance metrics 310 and repeating the process. Finally, if the current FOM needs to be adjusted towards the target FOM, the AIMM 100 is adjusted with the new tuning values in an effort to attain or achieve operation at the target FOM 340. In some embodiments, this new tuning value may also be stored as a new default tuning value of the transmitter at the given state of operation. For instance, in one embodiment, a single default value can be used for all situations, and as such, the latest tuning values could be stored in the variable location. In other embodiments, a default tuning state may be maintained for a variety of operational states, such as band of operation, use case scenario (i.e., hand held, antenna up/down, slider in/out, etc.) and depending on the current operational state, the new tuning values may be stored into the appropriate default variable.

In one exemplary embodiment, the AIMM 100 is adjusted by tuning one or more of the tunable components 340, measuring the new FOM (i.e., based on the transmitter reflected loss) 320-330, and re-adjusting or retuning the AIMM 100 accordingly 335-340 in a continuous loop. This process is referred to as walking the matching circuit because it moves the circuit from a non-matched state towards a matched state one step at a time. This process is continued or repeated to attain and/or maintain performance at the target FOM. Thus, the process identified by steps 310 to 340 can be repeated periodically, aperiodically, as needed, or otherwise. The looping is beneficial because even if performance at the target FOM is attained, adjustments may be necessary as the mode of operation (such as usage conditions) of the device change and/or the performance of the transmitter, the antenna and the matching circuitry change over time. In other embodiments, the tunable components can be set based on look-up tables or a combination of look-up tables and performing fine-tuning adjustments. For instance, the step of calculating the AIMM tuning values 335 may involve accessing initial values from a look-up table and then, on subsequent loops through the process, fine tuning the values of the components in the AIMM 100.

In an exemplary embodiment of the present invention operating within a TDM environment, the AIMM 100 can be adjusted to optimize the operation of the transmitter during the transmit time slot. In such an embodiment, the performance metric may simply be the transmitter return loss. In addition, the target FOM in such an embodiment may also simply be a function of the transmitter return loss. In this exemplary embodiment, the AIMM 100 can be tuned to minimize the FOM or the transmitter return loss.

More particularly, for the circuit illustrated in FIG. 2, this embodiment of the present invention can operate to tune the values of PTC1 and PTC2 to minimize the transmitter return loss during the transmit time slot. For this particular example, the algorithm of FIG. 3 includes measuring the transmitter return loss, calculating adjustment values for PTC1 and PTC2 to optimize a FOM that is a function of the transmitter return loss, tuning the AIMM 100 by adjusting the values of PTC1 and PTC2 and then repeating the process.

The adjustment values for PTC1 and PTC2 can be determined in a variety of manners. For instance, in one embodi-

ment of the invention the values may be stored in memory for various transmitter frequencies and usage scenarios. In other embodiments, the values may be heuristically determined on the fly by making adjustments to the tuning circuit, observing the effect on the transmitter return loss, and compensating accordingly. In yet another embodiment, a combination of a look-up table combined with heuristically determined fine tuning can be used to adjust the AIMM 100.

During the receiver time slot, the AIMM 100 can be readjusted to optimize or improve the performance of the receiver. Although, similar to the adjustments during the transmit time slot, particular performance parameters may be measured and used to calculate a current FOM, as previously mentioned it is difficult to measure such performance parameters for the receiver. As such, an exemplary embodiment of the present invention operates to apply a translation to the tuning values of the AIMM 100 derived at during the transmitter time slot, to improve the performance during the receive time slot. During the design of the transmitter and receiver circuitry, the characteristics of performance between the transmitter operation and receiver operation can be characterized. This characterization can then be used to identify an appropriate translation to be applied. The translation may be selected as a single value that is applicable for all operational states and use cases or, individual values can be determined for various operational states and use cases.

FIG. 4 is a plot of the transmitter reflection losses for four operating frequencies of a transceiver. The contours show the increasing magnitude of the reflection loss in 1 dB increments. For instance, in FIG. 4A, the inside contour for the transmitter 406 is 20 dB and the bolded contour is 404 14 dB. Obviously, operation at the center of the contours 402 is optimal during transmitter operation. In the illustrated example, it is apparent that simply by adjusting the value of PTC2 by adding an offset, significant performance improvements can be achieved in the receiver time slot by moving the operation towards point 412. The translation varies depending on a variety of circumstances and modes of operation including the frequency of operation, and similarly, may vary based on usage of the device housing the circuitry. In the illustrated example, the performance is determined to be greatly improved for the receiver time slot if the value of PTC2 for receiver operation is adjusted to be 0.6 times the value of PTC2 used for the optimal transmitter setting and the value of PTC1 remains the same. This is true for each of the illustrated cases except at the 915 MHz/960 MHz operational state. At 960 MHz, it is apparent that significant receiver improvement can be realized by also adjusting the value of PTC1 from its transmitter value. In the illustrated example, by examining the characteristics of the circuitry it can be empirically derived that a suitable equation for operation of the receiver at 960 MHz is:

$$PTC1_{Rx} = PTC1_{Tx} + 1 - 1.8 * PTC2_{Tx}.$$

It should be noted that this equation is only a non-limiting example of an equation that could be used for a particular circuit under particular operating conditions and the present invention is not limited to utilization of this particular equation.

FIG. 5 is a flow diagram illustrating the steps involved in an exemplary embodiment of the present invention operating in a TDM environment. During the transmitter time slot, the AIMM algorithm presented in FIG. 3, or some other suitable algorithm, can be applied on a continual basis to move operation of the transmitter towards the target FOM. However, when the receive time slot is activated 505, the

AIMM should be adjusted to match for the receiver frequency. The adjustment to the receiver mode of operation may initially involve determining the current operating conditions of the device **510**. Based on the current operating conditions, a translation for tuning of the various circuits in the AIMM **100** are identified **520**. For instance, various states, components or conditions can be sensed and analyzed to determine or detect a current state or a current use case for the device. Based on this information, a particular translation value or function may be retrieved and applied. It should also be appreciated that such translations can be determined during the design phase and loaded into the device. Finally, the translations are applied to the AIMM **100** **530**. When operation returns to the transmitter time slot **535**, the AIMM algorithm again takes over to optimize operation based on the target FOM.

It should be understood that the translation applied to tuning of the AIMM **100** during the receiver time slot is based on the particular circuit and device and can be determined during design or even on an individual basis during manufacturing and testing. As such, the specific translations identified herein are for illustrative purposes only and should not be construed to limit the operation of the present invention.

Thus, for TDM systems, embodiments of the present invention operate to optimize operation of a device by tuning the matching circuit for an antenna to optimize operation based on a target FOM. During the receiver time slot, a translation is applied to the tuned components to improve receiver performance. The target FOM can be based on a variety of performance metrics and a typical such metric is the reflection loss of the transmitter. The values for the tuned components can be set based on operational conditions and using a look-up table, can be initially set by using such a look-up table and then heuristically fine tuned, or may be heuristically determined on the fly during operation. The translations applied during the receiver operation are determined empirically based on the design of the circuitry and/or testing and measurements of the operation of the circuit. However, a unique aspect of the present invention is tuning of the matching circuit during transmit mode and based on non-receiver related metrics and then retuning the circuit during receive mode operation based on a translation to optimize or attain a desired level of receiver operation.

In an exemplary embodiment of the present invention operating within an FDM environment, the AIMM **100** can be adjusted to so that the matching characteristics represent a compromise between optimal transmitter and receiver operation. Several techniques can be applied to achieve this compromise. In one technique, the translation applied in the TDM example could be modified to adjust the AIMM **100** as a compromise between the optimal transmit and receive settings. For instance, in the example illustrated in FIG. **2**, the value of PTC1 and PTC2 can be determined and adjusted periodically, similar to TDM operation (even though such action would temporarily have an adverse effect on the receiver). Then, a translation could be applied to the values of PTC1 and PTC2 for the majority of the operation time. For instance, in the TDM example shown in FIG. **4**, the transmitter values were adjusted by multiplying the PTC2 value by 0.6 in three modes of operation and using the above-identified equation during a fourth mode of operation. This same scheme could be used in the FDM mode of operation however, the scaling factor would be different to obtain operation that is compromised between the optimal

transmitter setting and optimal receiver setting. For example, multiplying the PTC2 value by 0.8 could attain an acceptable compromise.

However, another technique of an embodiment of the present invention is to apply an algorithm that operates to attain a target FOM that is based on one or more transmitter related metrics (such as return loss) and the values of the adjustable components in the AIMM. Advantageously, this aspect of the present invention continuously attempts to maintain a compromised state of operation that keeps the operation of the transmitter and the receiver at a particular target FOM that represents a compromise performance metric level.

In the particular example illustrated in FIG. **2**, such an algorithm could be based on a target FOM that is an expression consisting of the transmitter return loss and the values of PTC1 and PTC2. Because the algorithm is not operating to minimize the transmitter return loss in this embodiment of an FDM system, a compromised value is specified. For instance, a specific target transmitter return loss can be pursued for both transmitter and receiver operation by tuning the AIMM based on a FOM that is not only a function of the return loss, but also a function of the values of PTC1 and PTC2 that will encourage operation at a specific level. The target FOM is attained when the actual transmitter return loss is equal to the target transmitter return loss and, specified preferences for PTC1 and PTC2 are satisfied. The preferences illustrated are for the value of PTC1 to be the highest possible value and the value of PTC2 to be the lowest possible value while maintaining the transmit return loss at the target value and satisfying the PTC1 and PTC2 preferences.

FIG. **6** is a return loss contour diagram in the PTC plane for a particular frequency (i.e., 825 MHz/870 MHz operation). Obviously, optimal operation in an FDM system cannot typically be attained because the settings for optimal transmitter operation most likely do not coincide with those for optimal receiver operation. As such, a compromise is typically selected. For instance, a compromise may include operating the transmitter at a target return loss value of -12 dB and at a point at which the transmitter -12 dB contour is closest to a desired receiver contour (i.e., -12 dB).

The operational goal of the system is to attempt to maintain the matching circuit at a point where the operational metrics for the transmitter are at a target value (eg. -12 dB) and the estimated desired receiver operation is most proximate. In an exemplary embodiment of the present invention, an equation used to express the target FOM for such an arrangement can be stated as follows:

$$\text{Target FOM} = f(\text{Tx_RL}, \text{Tx_RL_Target}) + f(\text{PTC2}, \text{PTC1})$$

Where: TX_RL is the measure transmitter return loss
TX_RL_Target is the targeted transmitter return loss

In an exemplary embodiment suitable for the circuit provided in FIG. **2**, the FOM may be expressed as:

$$\text{FOM} = (\text{Tx_RL} - \text{Tx_RL_Target}) + \text{C2} * \text{PTC2} - \text{C1} * \text{PTC1}, \text{ where,}$$

C1 and C2 are preference constants or scaled values, and if $\text{Tx_RL} > \text{Tx_RL_Target}$ then $\text{Tx_RL} = \text{Tx_RL_Target}$.

In operation, exemplary embodiments of the present invention optimize the transmitter based on the target reflected loss to attain operation on the desired contour **610** (as shown in FIG. **6**) and also adjusts the values of PTC1 and PTC2 to attain operation at the desired location **630** (or minimum FOM) on the contour. The portion of the FOM

equation including the TxRL and TX_RL_Target values ensures operation on the targeted RL contour **610** (i.e., the -12 db RL contour). By observing the contour **610**, it is quite apparent that not all points on the target reflected loss contour have the same value for the PTC1 and PTC2. Because of this, the values of PTC1 and PTC2 can be incorporated into the target FOM equation to force or encourage operation at a particular location on the reflected loss contour. In the illustrated example, the target FOM is the point at which the reflected loss contour is closest to the expected same valued reflected loss contour for the receiver. However, it will be appreciated that other performance goals may also be sought and the present invention is not limited to this particular example. For instance, in other embodiments, the target FOM may be selected to encourage operation at a mid-point between optimal transmitter performance and expected optimal receiver performance. In yet another embodiment, the target FOM may be selected to encourage operation at a point that is mid-point between a desired transmitter metric and an estimated or measured equivalent for the receiver metric.

In the provided example illustrated in FIG. 6, the optimum, compromised or desired point on the target contour is the point that minimizes the value of PTC2 and maximizes the value of PTC1 in accordance with the equation $C2*PTC2-C1*PTC1$. Thus, the portion of the expression including PTC1 and PTC2 ensures that operation is at a particular location on the contour that is desired—namely on the lower portion of the contour and closest to the RX_RL contour **620**. In general, the algorithm operates to optimize the current FOM or, more particularly in the illustrated embodiment, to minimize the expression of $C2*PTC2-C1*PTC1$ as long as the desired TX_RL parameter is also met. It should be appreciated that the details associated with this example are associated with a specific circuit design and a wide variety of relationships between the adjustable components of the AIMM would apply on a circuit by circuit basis and as such, the present invention is not limited to this specific example.

Another embodiment of the present invention may take into consideration historical performance of the tunable components as well as current values. As an example, as the tunable components are adjusted, changes in the current FOM will occur in a particular direction (i.e., better or worse). As an example, if the AIMM adjustments result in the current FOM falling on the top portion of a desired performance contour, making a particular adjustment may result in making the current FOM worse or better. If the adjustment was known to cause a certain result when the current FOM is located on the bottom of the contour and this time, the opposite result occurs, then this knowledge can help identify where the current FOM is located on the contour. Thus, knowing this information can be used in combination with the operation metric to attain the operation at the target FOM. For instance, the target FOM may be a function of the operational metrics, the current states of the tunable components, and the knowledge of previous results from adjusting the tunable components.

Stated another way, when a current FOM is calculated, the adjustments to reach the target FOM may take into consideration past reactions to previous adjustments. Thus, the adjustment to the tunable components may be a function of the FOM associated with a current setting and, the change in the current FOM resulting from previous changes to the tunable components.

In another embodiment of the present invention operating in an FDM environment, the FOM may be optimized similar

to operation in the TDM environment. For example, the FOM may be a function of the transmitter reflected loss metric and the system may function to optimize the FOM based on this metric. Once optimized, the tunable components can be adjusted based on a predetermined translation to move the FOM from the optimized for the transmitter position to a position that is somewhere between the optimal transmitter setting and the optimal receiver setting.

FIG. 7 is a flow diagram illustrating the steps involved in an exemplary embodiment of the present invention in obtaining the preference values for PTC1 and PTC2. Initially, the process **700** involves plotting of the return loss contours for the various modes of operation, or a reasonable subset thereof **710**. FIG. 6 is an example of such a plot generated as a result of performing this step. Next, the compromised tuning location is identified **720**. As previously mentioned, a variety of factors may be weighed to determine the compromised tuning location and one example, as illustrated in FIG. 6, is the point at which a target reflected loss for the transmitter is the most proximate to a target reflected loss for the receiver. In a typical embodiment, this is the point at which the target transmitter and receiver contours at the desired reflected loss are closest to each other and nearly parallel. Once the compromised location is determined, the preference values can be characterized **730**. For instance, in the example in FIG. 6, by drawing a perpendicular line between the two contours and passing through the compromised location, the slope and hence the preferences can be identified. These preference values can then be determined and then applied across the broad spectrum of frequencies and usage scenarios **740**.

It should be appreciated that the values of C1 and C2 are constants and can vary among embodiments of the invention, as well as among devices employing the invention. As such, the values are determined empirically as described above. In an exemplary embodiment, the values of C1 and C2 are 0.7 and 2 respectively for a given circuit and a given antenna, given mode of operation, etc. Thus, any given set of constants are determined empirically and only apply to a specific antenna design, circuit and mode of operation and, although the use of these specific values may in and of itself be considered novel, the present invention is not limited to the particular expression. In fact, depending on particular goals, design criteria, operational requirements, etc. different values may be required to attain the compromised performance. It will also be appreciated that in various embodiments, it may be desired to have a different targeted reflection loss for the transmitter than for the receiver.

In another embodiment of the present invention, rather than analyzing the transmitter reflected power as the performance metric, the reflection coefficient vector may be measured. In this embodiment, the phase information of the reflection coefficient may be included within the FOM. For example, FIG. 8 is a contour plot showing the magnitude and the phase of the reflection coefficient. The preferred point of operation **830** is shown as falling on the -12 dB contour **810** and at a phase of 45 degrees. In such an embodiment, the components of the matching circuit of the AIMM **100** can be adjusted to meet a reflected loss value that falls on the -12 db contour and that also approaches the specific point on the contour—namely at the point where the reflection coefficient differs by 45 degrees.

As mentioned, mobile and transportable transceivers are subjected to a variety of use cases. For instance, a typical cellular telephone could be operated in various scenarios including speaker phone mode, ear budded, with the antenna in the up position or the down position, in the user's hand,

holster, pocket, with a slider closed or extended, in a holster or out of a holster, etc. All of these scenarios, as well as a variety of other environmental circumstances can drastically alter the matching characteristics of the cellular telephone's antenna circuitry. As such, not only do the various embodiments of the present invention operate to tune the matching circuitry based on the operational frequency, but in addition, adjust the matching characteristics based on changes in the modes of operation. Advantageously, this greatly improves the performance of the device without requiring separate matching circuitry for the various modes of operation of the device. Thus, it will be appreciated that various other parameters can be monitored to identify various use cases and then adjustments to the tuning circuitry can be immediately deployed followed by fine tuning adjustments to optimize the FOM. The other parameters in which the embodiments of the present invention may function are referred to as modes of operation. The various modes of operation include the use cases as previously described, along with operating environments, bands of operation, channel frequencies, modulation formats and schemes, and physical environments. Thus, the various embodiments of the present invention may make changes, select default values, calculate adjustment values, etc., all as a function of one or more of the modes of operation.

One embodiment of the present invention may maintain a set of initial starting values based on the various use cases and operational environments. For instance, each use case may include a default value. Upon detection or activation of the device in a new use case, the default value is obtained from memory and the components in the AIMM are tuned accordingly. From that point on, the adjustment algorithm can then commence fine tuning of the operation. As previously mentioned, each time the target FOM is attained for a particular use case, the new values may be written into the default location as the new default values. Thus, every time the operational state of the device changes, such as changing between bands of operation etc., the default values are obtained and applied, and then adjustments can resume or operation can simply be held at the default value.

Numerous specific details have now been set forth to provide a thorough understanding of the invention. However, it will be understood by those skilled in the art that the present invention may be practiced without these specific details. In other instances, well-known methods, procedures, components and circuits have not been described in detail so as not to obscure the present invention.

Unless specifically stated otherwise, as apparent from the description, it is appreciated that throughout the specification discussions that different electronic devices could be used to create a variable tuner network. The embodiments used in the examples discussed were specific to variable capacitor devices, however variable inductors, or other tunable networks, built out of elements such as Micro-Electro-Mechanical Systems (MEMS) and/or other tunable variable impedance networks could be used in such an AIMM system.

Unless specifically stated otherwise, as apparent from the description, it is appreciated that throughout the specification discussions utilizing terms such as "processing," "computing," "calculating," "determining," or the like, refer to the action and/or processes of a microprocessor, microcontroller, computer or computing system, or similar electronic computing device, that manipulate and/or transform data represented as physical, such as electronic, quantities within the computing system's registers and/or memories into other data similarly represented as physical quantities within the

computing system's memories, registers or other such information storage, transmission or display devices.

Embodiments of the present invention may include apparatuses for performing the operations herein. An apparatus may be specially constructed for the desired purposes, or it may comprise a general purpose computing device selectively activated or reconfigured by a program stored in the device. Such a program may be stored on a storage medium, such as, but not limited to, any type of disk including floppy disks, optical disks, compact disc read only memories (CD-ROMs), magnetic-optical disks, read-only memories (ROMs), random access memories (RAMs), electrically programmable read-only memories (EPROMs), electrically erasable and programmable read only memories (EEPROMs), magnetic or optical cards, or any other type of media suitable for storing electronic instructions, and capable of being coupled to a system bus for a computing device.

The processes presented herein are not inherently related to any particular computing device or other apparatus. Various general purpose systems may be used with programs in accordance with the teachings herein, or it may prove convenient to construct a more specialized apparatus to perform the desired method. The desired structure for a variety of these systems will appear from the description below. In addition, embodiments of the present invention are not described with reference to any particular programming language. It will be appreciated that a variety of programming languages may be used to implement the teachings of the invention as described herein. In addition, it should be understood that operations, capabilities, and features described herein may be implemented with any combination of hardware (discrete or integrated circuits) and software.

Use of the terms "coupled" and "connected," along with their derivatives, may be used. It should be understood that these terms are not intended as synonyms for each other. Rather, in particular embodiments, "connected" may be used to indicate that two or more elements are in direct physical or electrical contact with each other. "Coupled" may be used to indicate that two or more elements are in either direct or indirect (with other intervening elements between them) physical or electrical contact with each other, and/or that the two or more elements co-operate or interact with each other (e.g. as in a cause and effect relationship).

In the description and claims of the present application, each of the verbs, "comprise," "include," and "have", and conjugates thereof, are used to indicate that the object or objects of the verb are not necessarily a complete listing of members, components, elements, or parts of the subject or subjects of the verb.

The present invention has been described using detailed descriptions of embodiments thereof that are provided by way of example and are not intended to limit the scope of the invention. The described embodiments comprise different features, not all of which are required in all embodiments of the invention. Some embodiments of the present invention utilize only some of the features or possible combinations of the features. Variations of embodiments of the present invention that are described and embodiments of the present invention comprising different combinations of features noted in the described embodiments will occur to persons of the art.

It will be appreciated by persons skilled in the art that the present invention is not limited by what has been particularly shown and described herein above. Rather the scope of the invention is defined by the claims that follow.

What is claimed is:

15

1. A method comprising:
 obtaining, by a processor of a communication device, an operational metric for a transceiver of the communication device;
 identifying a desired transmitter performance and a desired receiver performance;
 determining, by the processor, a target figure of merit based on a compromise between the desired transmitter performance and the desired receiver performance;
 determining, by the processor, a current figure of merit based on the operational metric;
 [comparing, by the processor, the current figure of merit to the target figure of merit;] and
 adjusting, by the processor, a variable reactance component of [an impedance matching circuit] *a variable tuner network* operably coupled with an antenna of the communication device, the adjusting of the variable reactance component being performed based on [the comparing of] the current and the target figures of merit, *wherein the obtaining of the operational metric is during a transmit mode of the transceiver of the communication device, wherein the variable reactance component is adjusted without utilizing operational metrics measured during a receive mode of the communication device.*
2. The method of claim 1, wherein the obtaining of the operational metric is during a transmit mode of the transceiver, wherein the variable reactance component is adjusted without utilizing operational metrics measured during a receive mode of the communication device.]
3. The method of claim 1, comprising communicating, by the communication device, utilizing frequency division multiplexing.
4. The method of claim 1, wherein the determining of the target figure of merit includes selecting a mid-point between the desired transmitter performance and the desired receiver performance.
5. The method of claim 1, wherein the determining of the current figure of merit is based on known parameters associated with the variable reactance component and is not based on phase information.
6. The method of claim 1, comprising:
 storing a tuning value based on the adjusting of the variable reactance component; and
 utilizing the tuning value as a default value for subsequent tuning of the antenna.
7. The method of claim 6, comprising:
 determining an operational state of the communication device; and
 utilizing information associated with the operational state as a default value for subsequent tuning of the antenna.
8. The method of claim 7, wherein the operational state comprises a use case scenario selected from the group consisting essentially of hand held operation, antenna position and slider position.
9. The method of claim 1, wherein the compromise between the desired transmitter performance and the desired receiver performance is based on an evaluation of total radiated power, *isotropic power or a combination thereof.*
10. The method of claim 1, wherein the compromise between the desired transmitter performance and the desired receiver performance is based on [an evaluation of total isotropic sensitivity] *a type of communication service.*
11. The method of claim 1, wherein the compromise between the desired transmitter performance and the desired receiver performance is based on an evaluation of transmitter linearity.

16

12. The method of claim 1, wherein the compromise between the desired transmitter performance and the desired receiver performance is based on an evaluation of transmitter efficiency.
13. A communication device comprising:
 an antenna;
 a transceiver;
 [an impedance matching] *a variable tuner network* coupled with the antenna [and the transceiver], wherein the [impedance matching] *variable tuner network* includes a variable reactance component;
 a memory to store computer instructions; and
 a controller coupled with the memory and the [impedance matching] *variable tuner network*, wherein the controller, responsive to executing the computer instructions, performs operations comprising:
 obtaining an operational metric associated with the [transceiver] *communication device*;
 identifying a desired transmitter performance and a desired receiver performance;
 determining a target figure of merit based on a compromise between the desired transmitter performance and the desired receiver performance;
 determining a current figure of merit based on the operational metric; and
 adjusting the variable reactance component of the [impedance matching circuit] *variable tuner network* based on [a comparison of] the current figure of merit [with] *and* the target figure of merit, *wherein the obtaining of the operational metric is during a transmit mode of the transceiver, and wherein the variable reactance component is adjusted without utilizing operational metrics measured during a receive mode of the communication device.*
14. The communication device of claim 13, *further comprising a transceiver*, wherein the variable reactance component includes a voltage tunable capacitor, and wherein the operations of the controller further comprise:
 determining a use case for the communication device; and
 performing an initial adjustment of the voltage tunable capacitor based on the use case without utilizing any operational metrics associated with the transceiver, wherein the initial adjustment of the voltage tunable capacitor is performed prior to the adjusting based on the comparison of the current figure of merit with the target figure of merit.
15. The communication device of claim 13, wherein the variable reactance component includes a Micro-Electro-Mechanical Systems (MEMS) variable reactance component.
16. The communication device of claim 13, wherein the operations of the controller further comprise:
 storing a tuning value based on the adjusting of the variable reactance component; and
 utilizing the tuning value as a default value for subsequent tuning of the antenna.
- [17. The communication device of claim 13, wherein the obtaining of the operational metric is during a transmit mode of the transceiver, and wherein the variable reactance component is adjusted without utilizing operational metrics measured during a receive mode of the communication device.]
18. The communication device of claim 13, wherein the adjusting of the variable reactance component is associated with a communication session that utilizes frequency division multiplexing.

19. A method comprising:
 obtaining an operational metric for a transceiver of a communication device;
 determining a target figure of merit based on transceiver performance of the communication device;
 determining a current figure of merit based on the operational metric, wherein the determining of the target figure of merit is not based on phase information;
 [comparing the current figure of merit to the target figure of merit to determine a figure of merit comparison;] and
 adjusting, by a processor of the communication device, a variable reactance component of [an impedance matching circuit] a variable tuner network operably coupled with an antenna of the communication device, the adjusting of the variable reactance component being performed based on the [figure] current and target figures of merit [comparison] and based on previous tuning results associated with [previous adjusting of the variable reactance component] the variable tuner network, wherein the obtaining of the operational metric is during a transmit mode of the transceiver, and wherein the variable reactance component is adjusted without utilizing operational metrics measured during a receive mode of the communication device.

20. The method of claim 19, comprising monitoring the previous tuning results by determining a change in the current figure of merit based on different reactance values for the variable reactance component.

21. The method of claim 19, wherein the operational metric comprises a return loss.

22. The method of claim 19, wherein the variable reactance component includes at least one of a Micro-Electro-Mechanical Systems (MEMS) variable reactance component and a voltage tunable capacitor.

23. The method of claim 19, wherein the current figure of merit, the target figure of merit or both is according to a vector measurement of a transmission reflection coefficient.

24. The method of claim 1, wherein the adjusting of the variable reactance component is based on tuning values stored in a lookup table.

25. A communication device comprising:

an antenna;

a transceiver;

a variable tuner network coupled with the antenna;

a memory that stores computer instructions; and

a controller coupled with the memory and the variable tuner network, wherein the controller, responsive to executing the computer instructions, performs operations comprising:

obtaining a non-receiver operational metric;

identifying a first desired performance of the communication device;

identifying a second desired performance of the communication device;

determining a target figure of merit based on a compromise between the first desired performance and the second desired performance;

determining a current figure of merit based on the non-receiver operational metric; and

adjusting a variable reactance of the variable tuner network based on the current figure of merit and the target figure of merit, wherein the obtaining of the operational metric is during a transmit mode of the transceiver, and wherein the variable reactance component is adjusted without utilizing operational metrics measured during a receive mode of the communication device.

26. The communication device of claim 25, wherein the target figure of merit is stored in a lookup table.

27. The communication device of claim 25, wherein the first desired performance is associated with a first component of the communication device, and wherein the second desired performance is associated with a second component of the communication device.

28. The communication device of claim 25, wherein the variable tuner network includes a Micro-Electro-Mechanical Systems (MEMS) variable reactance component.

29. The communication device of claim 25, wherein the variable tuner network includes a voltage tunable capacitor.

30. A communication device comprising:

an antenna;

a transceiver;

a variable tuner network coupled with the antenna;

a memory that stores computer instructions; and

a controller coupled with the memory and the variable tuner network, wherein the controller, responsive to executing the computer instructions, performs operations comprising:

obtaining an operational metric for communications of a communication device;

determining a target figure of merit based on communications performance of the communication device;

determining a current figure of merit based on the operational metric, wherein the determining of the target figure of merit is not based on phase information; and

adjusting the variable tuner network based on the current and target figures of merit, wherein the obtaining of the operational metric is during a transmit mode of the transceiver, and wherein the variable tuner network is adjusted without utilizing operational metrics measured during a receive mode of the communication device.

31. The communication device of claim 30, wherein the adjusting of the variable tuner network is further based on previous tuning results associated with previous adjusting of the variable tuner network.

32. The communication device of claim 30, wherein the operational metric comprises a return loss.

33. The communication device of claim 30, wherein the communications performance is associated with total radiated power, total isotropic sensitivity, linearity or a combination thereof.

34. The communication device of claim 30, wherein the variable tuner network includes a Micro-Electro-Mechanical Systems (MEMS) variable reactance component.

35. The communication device of claim 30, wherein the variable tuner network includes a voltage tunable capacitor.