



US00RE48351E

(19) **United States**  
(12) **Reissued Patent**  
**Uyehara et al.**

(10) **Patent Number:** **US RE48,351 E**  
(45) **Date of Reissued Patent:** **\*Dec. 8, 2020**

(54) **DISTRIBUTED DIGITAL REFERENCE CLOCK**

4,451,916 A 5/1984 Casper et al.  
(Continued)

(71) Applicant: **CommScope Technologies LLC**,  
Hickory, NC (US)  
(72) Inventors: **Lance K. Uyehara**, San Jose, CA (US);  
**Larry G. Fischer**, Waseca, MN (US);  
**David Hart**, Sunnyvale, CA (US);  
**Dean Zavadsky**, Shakopee, MN (US)  
(73) Assignee: **CommScope Technologies LLC**,  
Hickory, NC (US)

**FOREIGN PATENT DOCUMENTS**

CA 2058736 7/1993  
CA 2058737 7/1993  
(Continued)

(\*) Notice: This patent is subject to a terminal disclaimer.

(21) Appl. No.: **15/268,453**

(22) Filed: **Sep. 16, 2016**

**OTHER PUBLICATIONS**

European Patent Office, "Summons to Oral Proceedings in Examination Procedure for EP Application No. 14003681.5", "Foreign Counterpart to U.S. Appl. No. 12/845,060", Dated Jan. 24, 2018, pp. 1-11, Published in: EP.

(Continued)

**Related U.S. Patent Documents**

Reissue of:

(64) Patent No.: **8,837,659**  
Issued: **Sep. 16, 2014**  
Appl. No.: **13/914,838**  
Filed: **Jun. 11, 2013**

U.S. Applications:

(63) Continuation of application No. 12/845,060, filed on Jul. 28, 2010, now Pat. No. 8,472,579.

(51) **Int. Cl.**  
**H03L 7/00** (2006.01)  
**H04J 3/06** (2006.01)  
(Continued)

(52) **U.S. Cl.**  
CPC ..... **H04J 3/0685** (2013.01); **H04B 1/40** (2013.01); **H04L 7/0008** (2013.01); **H04W 28/04** (2013.01)

(58) **Field of Classification Search**  
None  
See application file for complete search history.

(56) **References Cited**

**U.S. PATENT DOCUMENTS**

4,183,054 A 1/1980 Patisaul et al.

*Primary Examiner* — John M Hotaling

(74) *Attorney, Agent, or Firm* — Fogg & Powers LLC

(57) **ABSTRACT**

A communication system includes master host unit, hybrid expansion unit, and remote antenna unit. Master host unit communicates analog signals with service provider interfaces. Master host unit and hybrid expansion unit communicate N-bit words of digitized spectrum over communication link. Hybrid expansion unit converts between N-bit words and analog spectrum. Hybrid expansion unit and remote antenna unit communicate analog spectrum over analog communication medium. Remote antenna unit transmits and receives wireless signals over air interfaces. Master host unit includes master clock distribution unit that generates digital master reference clock signal. Master host unit communicates digital master reference clock signal over communication link. Hybrid expansion unit receives digital master reference clock signal from master host unit over communication link and generates analog reference clock signal based on digital master reference clock signal. Hybrid expansion unit sends, and remote antenna unit receives, analog reference clock signal across analog communication medium.

**45 Claims, 7 Drawing Sheets**

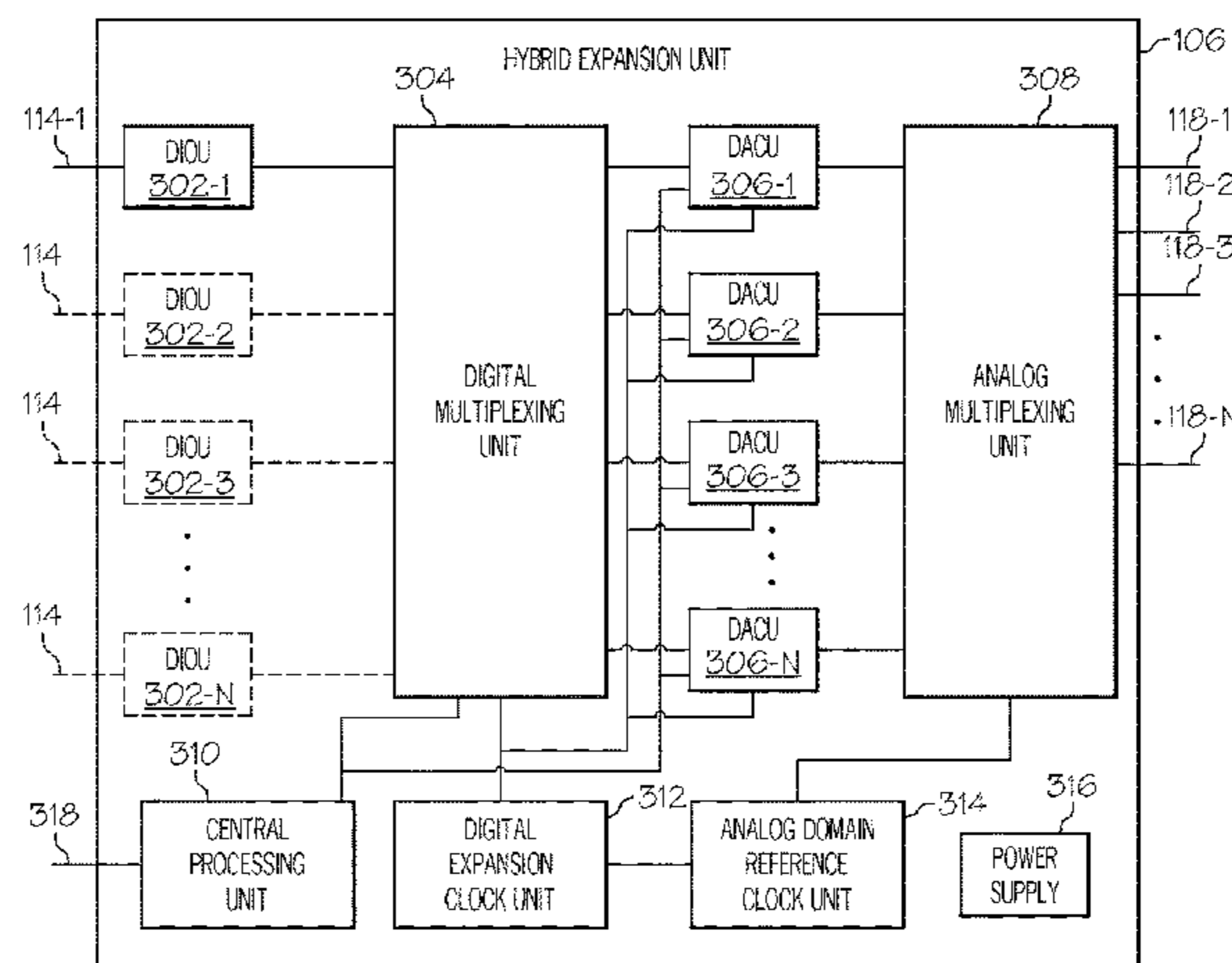

(51)	<b>Int. Cl.</b>		6,785,558 B1	8/2004	Stratford et al.
	<i>H04W 28/04</i>	(2009.01)	6,801,767 B1	10/2004	Schwartz et al.
	<i>H04L 7/00</i>	(2006.01)	6,807,374 B1	10/2004	Imajo et al.
	<i>H04B 1/40</i>	(2015.01)	6,826,163 B2	11/2004	Mani et al.
			6,826,164 B2	11/2004	Mani et al.
			6,831,901 B2	12/2004	Millar
(56)	<b>References Cited</b>		6,865,390 B2	3/2005	Goss et al.
	<b>U.S. PATENT DOCUMENTS</b>		6,917,614 B1	7/2005	Laubach et al.
			6,963,552 B2	11/2005	Sabat, Jr. et al.
			7,127,175 B2	10/2006	Mani et al.
			7,205,864 B2	4/2007	Schultz, Jr. et al.
	4,611,323 A	9/1986 Hessenmuller	7,215,651 B2	5/2007	Millar
	4,628,501 A	12/1986 Loscoe	7,289,972 B2	10/2007	Rieser et al.
	4,654,843 A	3/1987 Roza et al.	7,313,415 B2	12/2007	Wake et al.
	4,691,292 A	9/1987 Rothweiler	7,474,852 B1	1/2009	Jachetta et al.
	4,999,831 A	3/1991 Grace	7,733,901 B2	6/2010	Salkini et al.
	5,193,109 A	3/1993 Lee	7,761,093 B2	7/2010	Sabat, Jr. et al.
	5,243,598 A	9/1993 Lee	7,787,854 B2	8/2010	Conyers et al.
	5,303,287 A	4/1994 Laborde	7,920,858 B2	4/2011	Sabat, Jr. et al.
	5,321,736 A	6/1994 Beasley	8,027,270 B1	9/2011	Campana et al.
	5,321,849 A	6/1994 Lemson	8,462,683 B2	6/2013	Uyehara et al.
	5,339,184 A	8/1994 Tang	8,472,579 B2	6/2013	Uyehara et al.
	5,377,255 A	12/1994 Beasley	8,532,242 B2	9/2013	Fischer et al.
	5,381,459 A	1/1995 Lappington	8,693,342 B2	4/2014	Uyehara et al.
	5,400,391 A	3/1995 Emura et al.	8,837,659 B2	9/2014	Uyehara et al.
	5,461,627 A	10/1995 Rypinski	8,873,585 B2	10/2014	Oren et al.
	5,513,176 A	4/1996 Dean et al.	8,958,789 B2	2/2015	Bauman et al.
	5,519,691 A	5/1996 Darcie et al.	9,572,178 B1	2/2017	Sec et al.
	5,533,011 A	7/1996 Dean et al.	10,020,850 B2	7/2018	Wala et al.
	5,545,397 A	8/1996 Spielvogel et al.	2001/0036163 A1	11/2001	Sabat, Jr. et al.
	5,566,168 A	10/1996 Dent	2001/0044292 A1	11/2001	Jeon et al.
	5,621,786 A	4/1997 Fischer et al.	2002/0075906 A1	6/2002	Cole et al.
	5,627,879 A	5/1997 Russell et al.	2002/0142739 A1	10/2002	Smith
	5,634,191 A	5/1997 Beasley	2002/0167954 A1	11/2002	Highsmith et al.
	5,642,405 A	6/1997 Fischer et al.	2002/0191565 A1	12/2002	Mani et al.
	5,644,622 A	7/1997 Russell et al.	2003/0015943 A1	1/2003	Kim et al.
	5,657,374 A	8/1997 Russell et al.	2003/0043928 A1	3/2003	Ling et al.
	5,678,177 A	10/1997 Beasley	2003/0058814 A1	3/2003	Kim
	5,682,256 A	10/1997 Motley et al.	2003/0157943 A1	8/2003	Sabat, Jr.
	5,687,195 A	11/1997 Hwang et al.	2003/0203717 A1	10/2003	Chuprun et al.
	5,732,076 A	3/1998 Ketseoglou et al.	2004/0010609 A1	1/2004	Vilander et al.
	5,761,619 A	6/1998 Danne et al.	2004/0032354 A1	2/2004	Knobel et al.
	5,765,099 A	6/1998 Georges et al.	2004/0037565 A1	2/2004	Young et al.
	5,781,541 A	7/1998 Schneider	2004/0053602 A1	3/2004	Wurzburg
	5,781,859 A	7/1998 Beasley	2004/0106387 A1	6/2004	Bauman et al.
	5,802,173 A	9/1998 Hamilton-Piercy et al.	2004/0106435 A1	6/2004	Bauman et al.
	5,805,983 A	9/1998 Naidu et al.	2004/0132474 A1	7/2004	Wala
	5,809,395 A	9/1998 Hamilton-Piercy et al.	2004/0198453 A1	10/2004	Cutrer et al.
	5,822,324 A	10/1998 Kostrestsi et al.	2004/0203339 A1	10/2004	Bauman
	5,845,199 A	12/1998 Longshore	2004/0203703 A1	10/2004	Fischer
	5,852,651 A	12/1998 Fischer et al.	2004/0219950 A1	11/2004	Pallonen et al.
	5,867,485 A	2/1999 Chambers et al.	2005/0147067 A1	7/2005	Mani et al.
	5,870,392 A	2/1999 Ann	2005/0201323 A1	9/2005	Mani et al.
	5,890,055 A	3/1999 Chu et al.	2005/0250503 A1	11/2005	Cutrer
	5,907,544 A	5/1999 Rypinski	2005/0250541 A1	11/2005	Bird et al.
	5,914,963 A *	6/1999 Basile ..... 714/700	2006/0026017 A1 *	2/2006	Walker ..... 705/1
	5,924,022 A	7/1999 Beasley et al.	2006/0066484 A1	3/2006	Sayers
	5,987,014 A	11/1999 Magill et al.	2006/0094470 A1 *	5/2006	Wake et al. .... 455/562.1
	6,023,628 A	2/2000 Beasley	2006/0121944 A1	6/2006	Buscaglia et al.
	6,034,950 A	3/2000 Sauer et al.	2006/0153070 A1	7/2006	DelRegno et al.
	6,108,113 A	8/2000 Fee	2006/0172775 A1	8/2006	Conyers et al.
	6,108,550 A	8/2000 Wiorek et al.	2006/0193295 A1	8/2006	White et al.
	6,108,626 A	8/2000 Cellario et al.	2007/0008939 A1	1/2007	Fischer
	6,157,659 A	12/2000 Bird	2007/0147278 A1	6/2007	Millar
	6,157,810 A	12/2000 Georges et al.	2007/0274279 A1	11/2007	Wood et al.
	6,188,693 B1	2/2001 Murakami	2008/0181282 A1	7/2008	Wala et al.
	6,222,660 B1	4/2001 Traa	2008/0192855 A1	8/2008	Shapira et al.
	6,226,274 B1	5/2001 Reese et al.	2008/0240164 A1	10/2008	Zavadsky
	6,230,021 B1	5/2001 Ohdachi	2008/0287153 A1	11/2008	Fullam
	6,246,675 B1	6/2001 Beasley et al.	2009/0061940 A1	3/2009	Scheinert et al.
	6,373,887 B1	4/2002 Aiyagari et al.	2009/0067363 A1	3/2009	Ruiz et al.
	6,377,640 B2	4/2002 Trans	2009/0180407 A1	7/2009	Sabat et al.
	6,498,936 B1	12/2002 Raith	2009/0207942 A1	8/2009	Lin et al.
	6,567,473 B1	5/2003 Tzannes	2009/0316608 A1	12/2009	Singh et al.
	6,667,973 B1	12/2003 Gorshe et al.	2009/0316611 A1	12/2009	Stratford et al.
	6,674,966 B1	1/2004 Koonen	2010/0046494 A1	2/2010	Palanki et al.
	6,704,545 B1 *	3/2004 Wala ..... 455/16	2010/0093391 A1	4/2010	Saban et al.
	6,729,929 B1	5/2004 Sayers et al.	2010/0135276 A1	6/2010	Hedin et al.
	6,757,553 B1	6/2004 English	2010/0178936 A1	7/2010	Wala et al.
	6,768,745 B1	7/2004 Gorshe et al.			

(56)

## References Cited

## U.S. PATENT DOCUMENTS

2010/0215028	A1	8/2010	Fischer
2011/0143649	A1	6/2011	Sabat, Jr. et al.
2011/0237182	A1	9/2011	Stratford et al.
2011/0243291	A1	10/2011	McAllister et al.
2011/0280209	A1	11/2011	Wegener
2012/0027145	A1	2/2012	Uyehara et al.
2012/0177026	A1	7/2012	Uyehara et al.
2012/0281622	A1	11/2012	Saban et al.
2013/0017863	A1	1/2013	Kummetz et al.
2013/0272463	A1	10/2013	Uyehara et al.
2017/0181008	A1	6/2017	Fischer

## FOREIGN PATENT DOCUMENTS

CA	2069462	7/1993
CA	2087285	1/1994
CA	2138763	1/1994
CA	2156046	1/1995
CA	2125411	5/1995
CA	2128842	1/1996
CA	2134365	4/1996
CA	2158386	3/1997
CA	2168681	8/1997
CA	2215079	3/1999
CN	1455993	7/2001
CN	1719761	A 1/2006
CN	101018064	A 8/2007
CN	101283551	A 10/2008
CN	101355778	A 1/2009
CN	100466494	3/2009
CN	102084606	A 6/2011
CN	102084614	A 6/2011
EP	0391597	10/1990
EP	0876073	11/1998
EP	0935385	A2 8/1999
EP	1214809	3/2006
EP	2599240	12/2014
EP	2852071	3/2015
GB	2253770	9/1992
GB	2289198	11/1995
GB	2315959	2/1998
GB	2320653	6/1998
JP	2000333240	11/2000
JP	2001197012	7/2001
JP	2003023396	1/2003
JP	2004180220	6/2004
JP	2004194351	7/2004
KR	1020080015462	2/2008
KR	1020090113369	10/2009
KR	1020100011297	2/2010
KR	1020100080062	7/2010
WO	9115927	10/1991
WO	9413067	6/1994
WO	9533350	12/1995
WO	9628946	9/1996
WO	9716000	5/1997
WO	9732442	9/1997
WO	9824256	6/1998
WO	9937035	7/1999
WO	0117156	3/2001
WO	0174013	10/2001
WO	0174100	10/2001
WO	0182642	11/2001
WO	0209319	A1 1/2002
WO	03079645	9/2003
WO	2006135697	A1 12/2006
WO	2007075579	7/2007
WO	2008092067	A2 7/2008
WO	2009012448	A2 1/2009
WO	2009138876	11/2009
WO	2009151893	A2 12/2009
WO	2009155602	12/2009
WO	2012015892	2/2012

## OTHER PUBLICATIONS

China Patent Office, "First Office Action for CN Application No. 201610144515.8", "from Foreign Counterpart to U.S. Appl. No. 12/845,060", dated Oct. 10, 2017, pp. 1-11, Published in: CN.

European Patent Office, "Decision Revoking European Patent for EP Application No. 11813094.7", "from Foreign Counterpart to U.S. Appl. No. 12/845,060", dated Dec. 8, 2017, pp. 1-17, Published in: EP.

European Patent Office, "Minutes of EP Oral Proceedings for EP Application No. 11813094.7", "from Foreign Counterpart to U.S. Appl. No. 12/845,060", dated Dec. 8, 2017, pp. 1-6, Published in: EP.

United States Patent and Trademark Office, "Final Office Action", "From U.S. Appl. No. 14/849,870", dated Dec. 12, 2017, pp. 1-10, Published in: US.

China Patent Office, "First Office Action for CN Application No. 201480022991.1", "from Foreign Counterpart to U.S. Appl. No. 14/187,115", dated Nov. 6, 2017, pp. 1-27, Published in: CN.

U.S. Patent and Trademark Office, "Advisory Action", "from U.S. Appl. No. 14/187,115", dated Nov. 3, 2017, pp. 1-7, Published in: US.

Spectracom, "White Paper: A Master Clock Approach to Distributing Precision Time and Frequency", "https://spectracom.com/sites/default/files/document-files/Time\_and\_Frequency\_Distribution\_WP11-101\_A.pdf", Jan. 31, 2014, pp. 1-5, Publisher: Spectracomcorp.

Korean Patent Office, "Office Action for KR Application No. 10-2014-7017490", "from Foreign Counterpart to U.S. Appl. No. 12/913,179", dated Nov. 16, 2016, pp. 1-5, Published in: KR.

European Patent Office, "Summons to Attend Oral Proceedings for EP Application No. 11813094.7", "from U.S. Appl. No. 12/845,060", Jan. 11, 2017, pp. 1-20, Published in: EP.

Korean Patent Office, "Decision to Grant for KR Application No. 10-2014-7017490", "from foreign counterpart to U.S. Appl. No. 12/913,179", Feb. 1, 2017, pp. 1-6, Published in: KR.

European Patent Office, "European Search Report for EP Application No. 14754576.8-1874", "from Foreign Counterpart of U.S. Appl. No. 14/187,115", dated Sep. 21, 2016, pp. 1-7, Published in: EP.

U.S. Patent Office, "Decision on Request for Rehearing", "from U.S. Appl. No. 12/775,897", Jan. 6, 2016, pp. 1-13, Published in: US.

China Patent Office, "Second Office Action for Chinese Patent Application Serial No. 201210153142.2", "from Foreign Counterpart to U.S. Appl. No. 11/150,820", dated Oct. 24, 2014, pp. 1-7, Published in: CN.

European Patent Office, "Communication under Rule 71(3) EPC from EP Application No. 06772594.5 mailed Sep. 13, 2012", "from Foreign Counterpart of U.S. Appl. No. 11/150,820", Sep. 13, 2012, pp. 1-40.

European Patent Office, "Office Action from EP Application No. 06772594.5 dated Apr. 14, 2008", "from Foreign Counterpart of U.S. Appl. No. 11/150,820", Apr. 14, 2008, pp. 1-7, Published in: EP.

European Patent Office, "Office Action from EP Application No. 06772594.5 dated Oct. 5, 2009", "from Foreign counterpart of U.S. Appl. No. 11/150,820", Oct. 5, 2009, pp. 1-3, Published in: EP.

European Patent Office, "Office Action from EP Application No. 06772594.5 dated Nov. 12, 2010", "from Foreign counterpart of U.S. Appl. No. 11/150,820", Nov. 12, 2010, pp. 1-5, Published in: EP.

European Patent Office, "Office Action from EP Application No. 06772594.5 dated Nov. 3, 2011", "from Foreign counterpart of U.S. Appl. No. 11/150,820", Nov. 3, 2011, pp. 1-3, Published in: EP.

Japan Patent Office, "Notification of Reasons for Rejection from JP Application No. 2008-515931 dated Nov. 1, 2011", "from Foreign Counterpart of U.S. Appl. No. 11/150,820", Nov. 1, 2011, pp. 1-10, Published in: JP.

Japan Patent Office, "Decision of Final Rejection from JP Application No. 2008-515931 dated Feb. 28, 2012", "from Foreign Counterpart of U.S. Appl. No. 11/150,820", Feb. 28, 2012, pp. 1-8, Published in: JP.

(56)

## References Cited

## OTHER PUBLICATIONS

- Korean Patent Office, "Office Action from KR Application No. 2007-7030470 dated Sep. 17, 2012", "from Foreign Counterpart of U.S. Appl. No. 11/150,820", Sep. 17, 2012, pp. 1-5, Published in: KR.
- Korean Patent Office, "Decision to Grant for Korean Patent Application No. 2007/7030470", "from Foreign Counterpart to U.S. Appl. No. 11/150,820", dated Jul. 17, 2013, pp. 1-6, Published in: KR.
- U.S. Patent and Trademark Office, "Advisory Action", "from U.S. Appl. No. 11/150,820", dated Apr. 30, 2014, pp. 1-3, Published in: US.
- U.S. Patent Office, "Decision on Appeal", "from U.S. Appl. No. 11/150,820", dated Jul. 6, 2016, pp. 1-10, Published in: US.
- U.S. Patent and Trademark Office, "Decision on Appeal", "U.S. Appl. No. 11/150,820", dated Nov. 19, 2012, pp. 1-6.
- U.S. Patent and Trademark Office, "Examiner's Answer", "U.S. Appl. No. 11/150,820", dated Nov. 17, 2009, pp. 1-24.
- U.S. Patent Office, "Examiner's Answer", "from U.S. Appl. No. 11/150,820", dated Nov. 4, 2014, pp. 1-31.
- U.S. Patent and Trademark Office, "Final Office Action", "U.S. Appl. No. 11/150,820", dated Sep. 27, 2007, pp. 1-25.
- U.S. Patent and Trademark Office, "Final Office Action", "U.S. Appl. No. 11/150,820", dated Dec. 29, 2008, pp. 1-27.
- U.S. Patent and Trademark Office, "Office Action", "U.S. Appl. No. 11/150,820", dated Mar. 16, 2007, pp. 1-21.
- U.S. Patent Office, "Office Action", "from U.S. Appl. No. 11/150,820", dated Sep. 6, 2013, pp. 1-31.
- U.S. Patent and Trademark Office, "Pre-Appeal Brief Decision", "from U.S. Appl. No. 11/150,820", Jun. 19, 2014, pp. 1-2, Published in: US.
- U.S. Patent Office, "Decision on Appeal", "from U.S. Appl. No. 12/775,897", Sep. 2, 2015, pp. 1-12, Published in: US.
- U.S. Patent and Trademark Office, "Examiner's Answer", "U.S. Appl. No. 12/775,897", dated Jan. 4, 2013, pp. 1-30.
- U.S. Patent and Trademark Office, "Final Office Action", "U.S. Appl. No. 12/775,897", dated May 7, 2012, pp. 1-26.
- U.S. Patent and Trademark Office, "Office Action", "U.S. Appl. No. 12/775,897", dated Dec. 28, 2011, pp. 1-29.
- U.S. Patent and Trademark Office, "Pre-Appeal Brief Decision", "U.S. Appl. No. 12/775,897", dated Sep. 18, 2012, pp. 1-2.
- International Preliminary Examining Authority, "International Preliminary Report on Patentability from PCT Application No. PCT/US2006/022342 dated Dec. 27, 2007", "from Foreign Counterpart of U.S. Appl. No. 11/150,820", Dec. 27, 2007, pp. 1-9, Published in: WO.
- International Searching Authority, "International Search Report and Written Opinion from PCT Application No. PCT/US2006/022342 dated Nov. 7, 2006", "from Foreign Counterpart of U.S. Appl. No. 11/150,820", Nov. 7, 2006, pp. 1-13, Published in: WO.
- "Tektronix Synchronous Optical Network (Sonet)", "<http://www.iec.org/online/tutorials/sonet/topic03.html>", Aug. 28, 2002, pp. 1-5, Publisher: International Engineering Consortium.
- Canadian Intellectual Property Office, "Office Action for CA Application No. 2,803,013", "Foreign Counterpart from U.S. Appl. No. 12/845,060", dated Jun. 1, 2017, pp. 1-4, Published in: CA.
- United States Patent and Trademark Office, "Office Action", "From U.S. Appl. No. 14/849,870", dated Jul. 21, 2017, pp. 1-58, Published in: US.
- United States Patent and Trademark Office, "Final Office Action", "From U.S. Appl. No. 14/187,115", dated Aug. 10, 2017, pp. 1-26, Published in: US.
- European Patent Office, "Extended European Search Report from EP Application No. 11813094.7 dated Aug. 14, 2013", "from Foreign Counterpart of U.S. Appl. No. 12/845,060", Aug. 14, 2013, pp. 1-6, Published in: EP.
- U.S. Patent and Trademark Office, "Notice of Allowance", "U.S. Appl. No. 12/845,060", dated Mar. 4, 2013, pp. 1-10.
- U.S. Patent and Trademark Office, "Corrected Notice of Allowability and Interview Summary", "U.S. Appl. No. 12/845,060", dated Mar. 28, 2013, pp. 1-25.
- U.S. Patent and Trademark Office, "Office Action", "U.S. Appl. No. 12/845,060", dated Oct. 2, 2012, pp. 1-28.
- U.S. Patent and Trademark Office, "Notice of Allowance", "from U.S. Appl. No. 13/914,838", dated May 15, 2014, pp. 1-16, Published in: US.
- U.S. Patent and Trademark Office, "Office Action", "from U.S. Appl. No. 13/914,838", dated Nov. 20, 2013, pp. 1-47, Published in: US.
- International Preliminary Examining Authority, "International Preliminary Report on Patentability from PCT Application No. PCT/US2011/045495 dated Feb. 7, 2013", "from Foreign Counterpart of U.S. Appl. No. 12/845,060", Feb. 7, 2013, pp. 1-6, Published in: WO.
- International Searching Authority, "International Search Report and Written Opinion from PCT Application No. PCT/US2011/045495 dated Feb. 17, 2012", "from Foreign Counterpart of U.S. Appl. No. 12/845,060", Feb. 17, 2012, pp. 1-9, Published in: WO.
- Canadian Intellectual Property Office, "Notice of Allowance from CA Application No. 2,815,509 dated Jun. 12, 2014", "from Foreign Counterpart of U.S. Appl. No. 12/913,179", Jun. 12, 2014, p. 1 Published in: CA.
- Korean Intellectual Property Office, "Office Action from KR Application No. 2013-7013076 dated Mar. 26, 2014", "from Foreign Counterpart of U.S. Appl. No. 12/913,179", Mar. 26, 2014, pp. 1-6, Published in: KR.
- International Preliminary Examining Authority, "International Preliminary Report on Patentability from PCT Application No. PCT/US2011/057575 dated May 10, 2013", "from Foreign Counterpart of U.S. Appl. No. 12/913,179", May 10, 2013, pp. 1-7, Published in: WO.
- U.S. Patent and Trademark Office, "Office Action", "U.S. Appl. No. 12/913,179", dated Mar. 18, 2013, pp. 1-49.
- International Searching Authority, "International Search Report and Written Opinion from PCT Application No. PCT/US2011/057575 dated Feb. 17, 2012", "from Foreign Counterpart of U.S. Appl. No. 12/913,179", Feb. 17, 2012, pp. 1-10, Published in: WO.
- International Searching Authority, "International Search Report and Written Opinion from PCT Application No. PCT/US2014/017643 dated Jun. 2, 2014", "from PCT Counterpart of U.S. Appl. No. 14/187,115", Jun. 2, 2014, pp. 1-16, Published in: WO.
- Chinese Patent Office, "Notification to Grant Patent Right for Invention from CN Application No. 200680029629.2 dated Mar. 2, 2012", "from Foreign Counterpart of U.S. Appl. No. 11/150,820", Mar. 2, 2012, pp. 1-4, Published in: CN.
- Chinese Patent Office, "First Office Action from CN Application No. 200680029629.2 dated Oct. 9, 2010", "from Foreign Counterpart of U.S. Appl. No. 11/150,820", Oct. 9, 2010, pp. 1-33, Published in: CN.
- Chinese Patent Office, "Second Office Action from CN Application No. 200680029629.2 dated Aug. 10, 2011", "from Foreign Counterpart of U.S. Appl. No. 11/150,820", Aug. 10, 2011, pp. 1-31, Published in: CN.
- Chinese Patent Office, "Third Office Action from CN Application No. 200680029629.2 dated Nov. 16, 2011", "from Foreign Counterpart of U.S. Appl. No. 11/150,820", Nov. 16, 2011, pp. 1-10, Published in: CN.
- State Intellectual Property Office, P.R. China, "First Office Action from CN Application No. 201210153142.2 dated Feb. 25, 2014", "from Foreign Counterpart of U.S. Appl. No. 11/150,820", Feb. 25, 2014, pp. 1-31, Published in: CN.
- Chinese Patent Office, "Notification to Grant for China Application No. 201210153142.2", "from Foreign Counterpart to U.S. Appl. No. 11/150,820", Jul. 10, 2015, pp. 1-4, Published in: CN.
- Chinese Patent Office, "Notification to Grant Patent Right for CN Application No. 201180036792.2", "from Foreign Counterpart to U.S. Appl. No. 12/845,060", dated Dec. 30, 2015, pp. 1-5, Published in: CN.
- Chinese Patent Office, "First Office Action for CN Application No. 201180036792.2", "from Foreign Counterpart to U.S. Appl. No. 12/845,060", dated Mar. 3, 2015, pp. 1-25, Published in: CN.

(56)

**References Cited**

## OTHER PUBLICATIONS

Chinese Patent Office, “Second Office Action for CN Application No. 201180036792.2”, “from Foreign Counterpart to U.S. Appl. No. 12/845,060”, dated Aug. 28, 2015, pp. 1-22, Published in: CN.

European Patent Office, “Communication under Rule 71(3)”, “from Foreign Counterpart to U.S. Appl. No. 12/845,060”, Jul. 8, 2014, pp. 1-45, Published in: EP.

European Patent Office, “Notice of Opposition for EP Application No. 11813094.7”, “from Foreign Counterpart to U.S. Appl. No. 12/845,060”, Sep. 28, 2015, pp. 1-96, Published in: EP.

European Patent Office, “Notice of Opposition for EP Application No. 11813094.7”, “from Foreign Counterpart to U.S. Appl. No. 12/845,060”, Oct. 22, 2015, p. 1 Published in: EP.

European Patent Office, “Communication pursuant to Rule 161(2) and 162 EPC for EP Application No. 11813094.7”, “from Foreign Counterpart to U.S. Appl. No. 12/845,060”, Mar. 15, 2013, pp. 12, Published in: EP.

European Patent Office, “Communication pursuant to Rules 70(2) and 70a(2) EPC”, “from Foreign Counterpart to U.S. Appl. No. 12/845,060”, Aug. 30, 2013, p. 1 Published in: EP.

European Patent Office, “European Search Report for EP Application No. 14003681.5”, “from Foreign counterpart to U.S. Appl. No. 12/845,060”, dated Apr. 7, 2015, pp. 1-4, Published in: EP.

European Patent Office, “Office Action for EP Application No. 14003681.5”, “from Foreign Counterpart to U.S. Appl. No. 12/845,060”, dated Mar. 9, 2016, pp. 1-6, Published in: EP.

Korean Patent Office, “Decision to Grant for Korean Patent Application No. 2012-7034310”, “from Foreign Counterpart to U.S. Appl. No. 12/845,060”, Jan. 27, 2014, pp. 1-6, Published in: KR.

U.S. Patent Office, “Advisory Action”, “from U.S. Appl. No. 14/187,115”, dated Sep. 29, 2016, pp. 1-8, Published in: US.

U.S. Patent Office, “Final Office Action”, “from U.S. Appl. No. 14/187,115”, dated Jul. 15, 2016, pp. 1-31, Published in: US.

U.S. Patent Office, “Interview Summary”, “from U.S. Appl. No. 14/187,115”, dated Oct. 21, 2016, pp. 1-3, Published in: US.

U.S. Patent Office, “Office Action”, “from U.S. Appl. No. 14/187,115”, dated Nov. 18, 2015, pp. 1-46, Published in: US.

European Patent Office, “Decision to Grant from EP Application No. 11813094.7 dated Nov. 20, 2014” from Foreign Counterpart of U.S. Appl. No. 12/845,060; pp. 1; Published in: EP.

European Patent Office, “EP Result of Consultation from EP Application 11813094.7 dated Sep. 11, 2017”, from Foreign Counterpart of U.S. Appl. No. 12/845,060; pp. 1-4; Published in EP.

State Intellectual Property Office, People’s Republic of China, “First Office Action from CN Application No. 201610670195.X dated May 25, 2018”, from Foreign Counterpart of U.S. Appl. No. 12/913,179; pp. 1-10; Published in China.

Canadian Intellectual Property Office, “Office Action from CA Application No. 2,815,509 dated Sep. 30, 2013”, From Foreign Counterpart of U.S. Appl. No. 12/913,179, pp. 1-2, Published: CA.

European Patent Office, “Communication under Rule 71(3) for EP Application No. 06772594.5 dated Aug. 6, 2012”, “Foreign Counterpart to U.S. Appl. No. 11/150,820”, dated Aug. 6, 2012, pp. 1-6, Published in: EP.

European Patent Office, “Extended European Search Report from EP Application No. 11836933.9 dated Oct. 21, 2015” “From Foreign Counterpart of U.S. Appl. No. 12/913,179”, pp. 1-9, Published: EP.

State Intellectual Property Office, P.R. China, “First Office Action for CN Application No. 201180063065 dated Apr. 21, 2015”, “Foreign Counterpart to U.S. Appl. No. 12/913,179”, dated Apr. 21, 2015, pp. 1-14, Published in: CN.

State Intellectual Property Office, P.R. China, “Search Report for CN Application No. 201180063065.5 dated Dec. 1, 2015”, “Foreign Counterpart to U.S. Appl. No. 12/913,179”, dated Dec. 1, 2015, pp. 1-2, Published in: CN.

State Intellectual Property Office, P.R. China, “Second Office Action for CN Application No. 201180063065.5 dated Dec. 9, 2015”, “Foreign Counterpart to U.S. Appl. No. 12/913,179”, dated Dec. 9, 2015, pp. 1-9, Published in: CN.

U.S. Patent and Trademark Office, “Decision on Request for Rehearing”, U.S. Appl. No. 11/150,820, dated Dec. 29, 2016, pp. 1-8, Published: US.

U.S. Patent and Trademark Office, “Interview Summary”, U.S. Appl. No. 11/150,820, dated Dec. 11, 2007, p. 1, Published: US.

U.S. Patent and Trademark Office, “Interview Summary”, U.S. Appl. No. 14/187,115, dated May 8, 2017, pp. 1-3, Published: US.

U.S. Patent and Trademark Office, “Notice of Allowance for U.S. Appl. No. 14/187,115”, dated Feb. 27, 2018, pp. 1-14, Published in: US.

U.S. Patent and Trademark Office, “Notice of Allowance”, U.S. Appl. No. 12/913,179, dated Jul. 19, 2013, pp. 1-20, Published: US.

U.S. Patent and Trademark Office, “Notice of Allowance”, U.S. Appl. No. 14/849,870, dated May 22, 2018, pp. 1-18, Published: US.

U.S. Patent and Trademark Office, “Office Action for U.S. Appl. No. 14/187,115”, dated Dec. 30, 2016, pp. 1-25, Published in: US.

U.S. Patent and Trademark Office, “Supplemental Notice of Allowability for U.S. Appl. No. 14/187,115”, dated Mar. 14, 2018, pp. 1-4, Published in: US.

U.S. Patent and Trademark Office, “Supplemental Notice of Allowability for U.S. Appl. No. 14/187,115”, dated Jun. 13, 2018, pp. 1-6, Published in: US.

European Patent Office, “Decision to refuse a European Patent application from EP Application No. 14003681.5 dated Jan. 25, 2019”, from Foreign Counterpart to U.S. Appl. No. 12/845,060, dated Jan. 25, 2019, pp. 1-28, Published: EP.

U.S. Patent and Trademark Office, “Office Action”, U.S. Appl. No. 16/030,642, dated Jun. 4, 2019, pp. 1-17, Published: US.

European Patent Office, “Extended European Search Report from EP Application No. 19159426.6 dated Jun. 13, 2019”, from Foreign Counterpart to U.S. Appl. No. 12/913,179, pp. 1-12, Published: EP.

U.S. Patent and Trademark Office, “Office Action”, U.S. Appl. No. 15/448,315, dated Dec. 13, 2018, pp. 1-10.

European Patent Office, “Extended European Search Report from EP Application No. 18211421.5 dated Feb. 12, 2019”, from Foreign Counterpart to U.S. Appl. No. 14/187,115, dated Feb. 12, 2019, pp. 1-8, Published: EP.

State Intellectual Property Office, P.R. China, “Second Office Action from CN Application No. 201610670195.X dated Feb. 15, 2019”, from Foreign Counterpart to U.S. Appl. No. 12/913,179, pp. 1-18, Published: CN.

U.S. Patent and Trademark Office, “Office Action”, U.S. Appl. No. 16/277,816, dated Aug. 23, 2019, pp. 1-11, Published: US.

U.S. Patent and Trademark Office, “Final Office Action”, U.S. Appl. No. 15/448,315, dated Sep. 5, 2019, pp. 1-11, Published: US.

U.S. Patent and Trademark Office, “Office Action”, U.S. Appl. No. 16/215,391, dated Nov. 4, 2019, pp. 1-28, Published: US.

U.S. Patent and Trademark Office, “Advisory Action”, U.S. Appl. No. 15/448,315, dated Nov. 19, 2019, pp. 1-4, Published: US.

“Flexwave Spectrum One Solution to Your Wireless Services”, at least as early as Dec. 12, 2014, pp. 1 through 8, TE Connectivity Ltd.

“InterResearch Spectrum”, at least as early as Sep. 12, 2011, pp. 1 through 12, GraybaR, TE Connectivity Ltd.

Andrew Wireless Solutions, “ION Series IONTM—B Series”, at least as early as Feb. 26, 2008, pp. 1 through 4, CommScope.

Canadian Intellectual Property Office, “Office Action from CA Application No. 2914104”, from Foreign Counterpart to U.S. Appl. No. 14/187,115, dated Jan. 15, 2020, pp. 1-6, Published: CA.

European Patent Office, “Communication to the parties concerning termination of opposition proceedings from EP Application No. 11813094.7”, from Foreign Counterpart to U.S. Appl. No. 12/845,060, dated Mar. 23, 2018, pp. 1, Published: EP.

European Patent Office, “Noting loss of rights pursuant to Rule 112(1) EPC from EP Application No. 14003681.5”, from Foreign Counterpart to U.S. Appl. No. 12/845,060, dated Oct. 18, 2016, pp. 1, Published: EP.

Korean Intellectual Property Office, “Notice to File Response from KR Application No. 10-2015-7024364”, from Foreign Counterpart to U.S. Appl. No. 14/187,115, dated Feb. 17, 2020, pp. 1 through 23, Published: KR.

(56)

**References Cited**

OTHER PUBLICATIONS

State Intellectual Property Office, P.R. China, "Notification to Grant Patent Right for Invention for CN Application No. 201610144515.8 dated May 4, 2018", "Foreign Counterpart to U.S. Appl. No. 12/845,060", dated May 4, 2018, pp. 1-7, Published in: CN.

U.S. Patent and Trademark Office, "Advisory Action", U.S. Appl. No. 16/277,816, dated Apr. 23, 2020, pp. 1 through 2, Published: US.

U.S. Patent and Trademark Office, "Advisory Action", U.S. Appl. No. 16/030,642, dated Apr. 2, 2020, pp. 1 through 12, Published: US.

U.S. Patent and Trademark Office, "Final Office Action", U.S. Appl. No. 16/030,642, dated Jan. 7, 2020, pp. 1 through 48, Published: US.

U.S. Patent and Trademark Office, "Final Office Action", U.S. Appl. No. 16/215,391, dated Apr. 16, 2020, pp. 1 through 54, Published: US.

U.S. Patent and Trademark Office, "Final Office Action", U.S. Appl. No. 16/277,816, dated Jan. 30, 2020, pp. 1-58, Published: US.

U.S. Patent and Trademark Office, "Office Action", U.S. Appl. No. 15/448,315, dated Feb. 26, 2020, pp. 1-62, Published: US.

International Preliminary Examining Authority, "International Preliminary Report on Patentability", "from Foreign Counterpart of U.S. Appl. No. 12/845,060", Feb. 7, 2013, pp. 1-6, Published in: WO.

U.S. Patent and Trademark Office, "Office Action", "U.S. Appl. No. 11/150,820", Mar. 24, 2008, pp. 1-17.

"DigivanceTM, Indoor Coverage Solution", "www.adc.com", 2001, pp. 1-8, Publisher: ADC.

Grace, Martin K., "Synchronous Quantized Subcarrier Multiplexing for Transport of Video, Voice and Data", "IEEE Journal on Selected Areas in Communications", Sep. 1990, pp. 1351-1358, vol. 8, No. 7, Publisher: IEEE.

Harvey et al., "Cordless Communications Utilising Radio Over Fibre Techniques for the Local Loop", "IEEE International Conference on Communications", Jun. 1991, pp. 1171-1175, Publisher: IEEE.

U.S. Patent and Trademark Office, "Final Office Action", from U.S. Appl. No. 11/150,820, dated Feb. 6, 2014, pp. 1-20, Published in: US.

\* cited by examiner

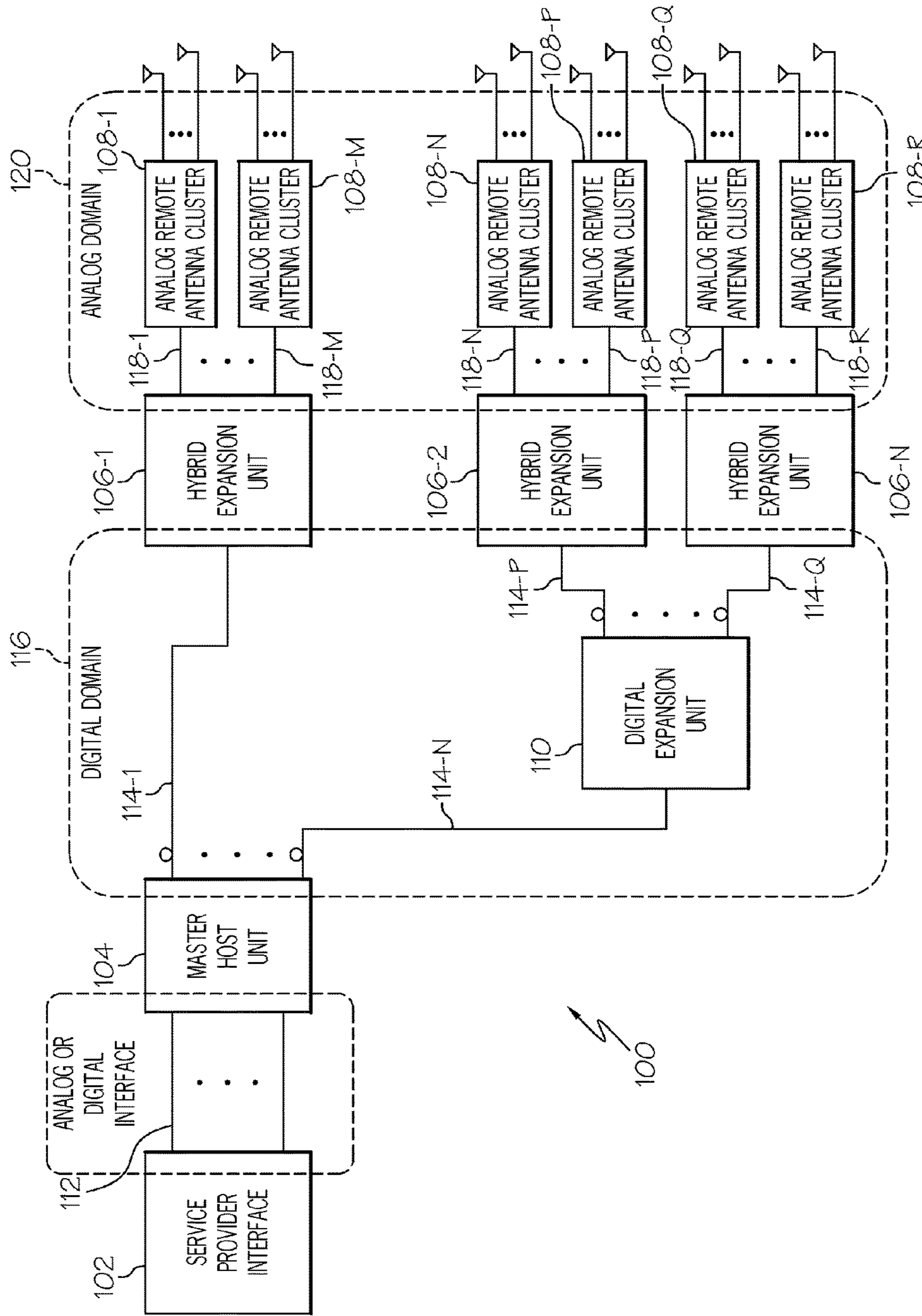

FIG. 1

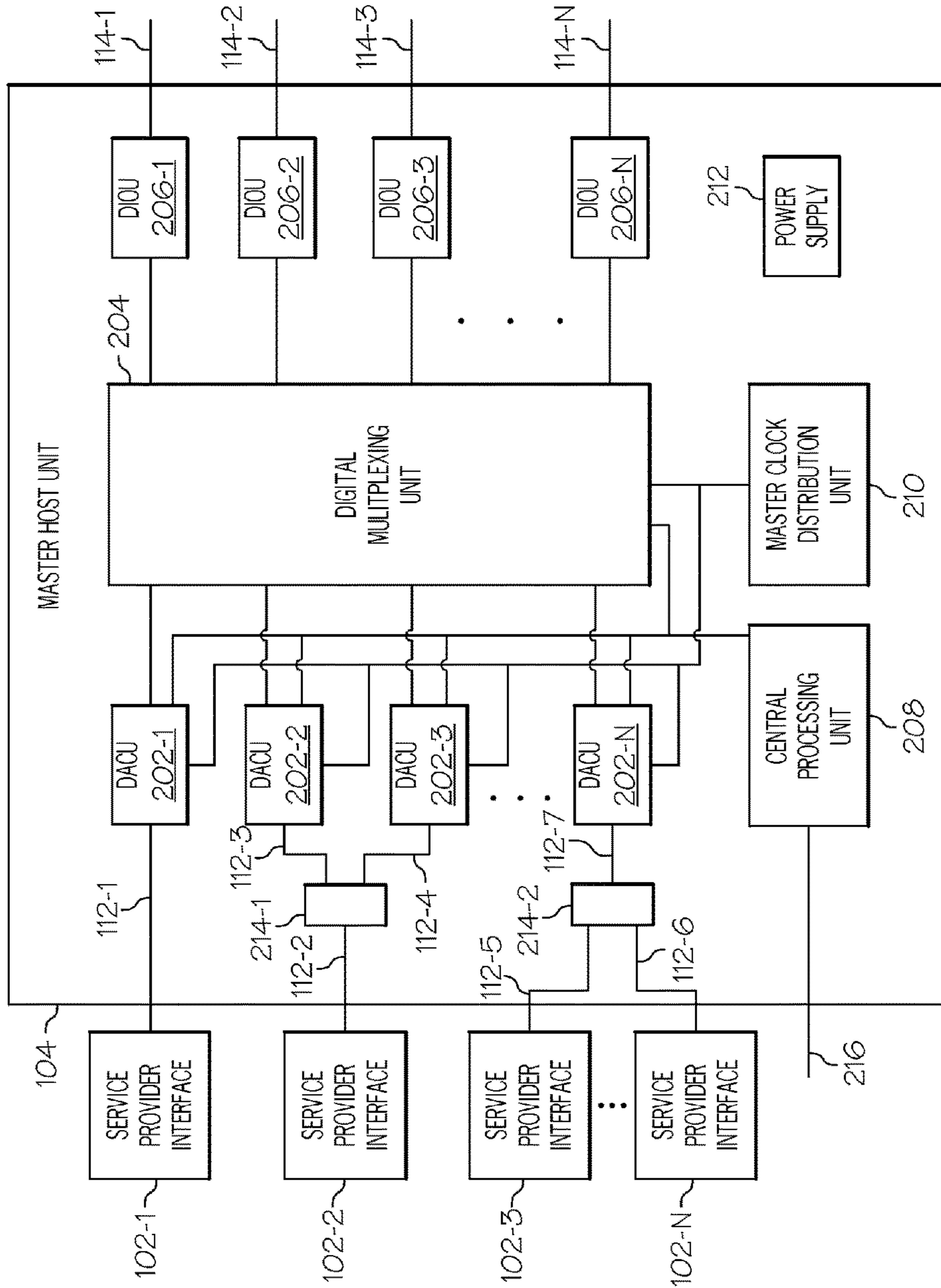

FIG. 2



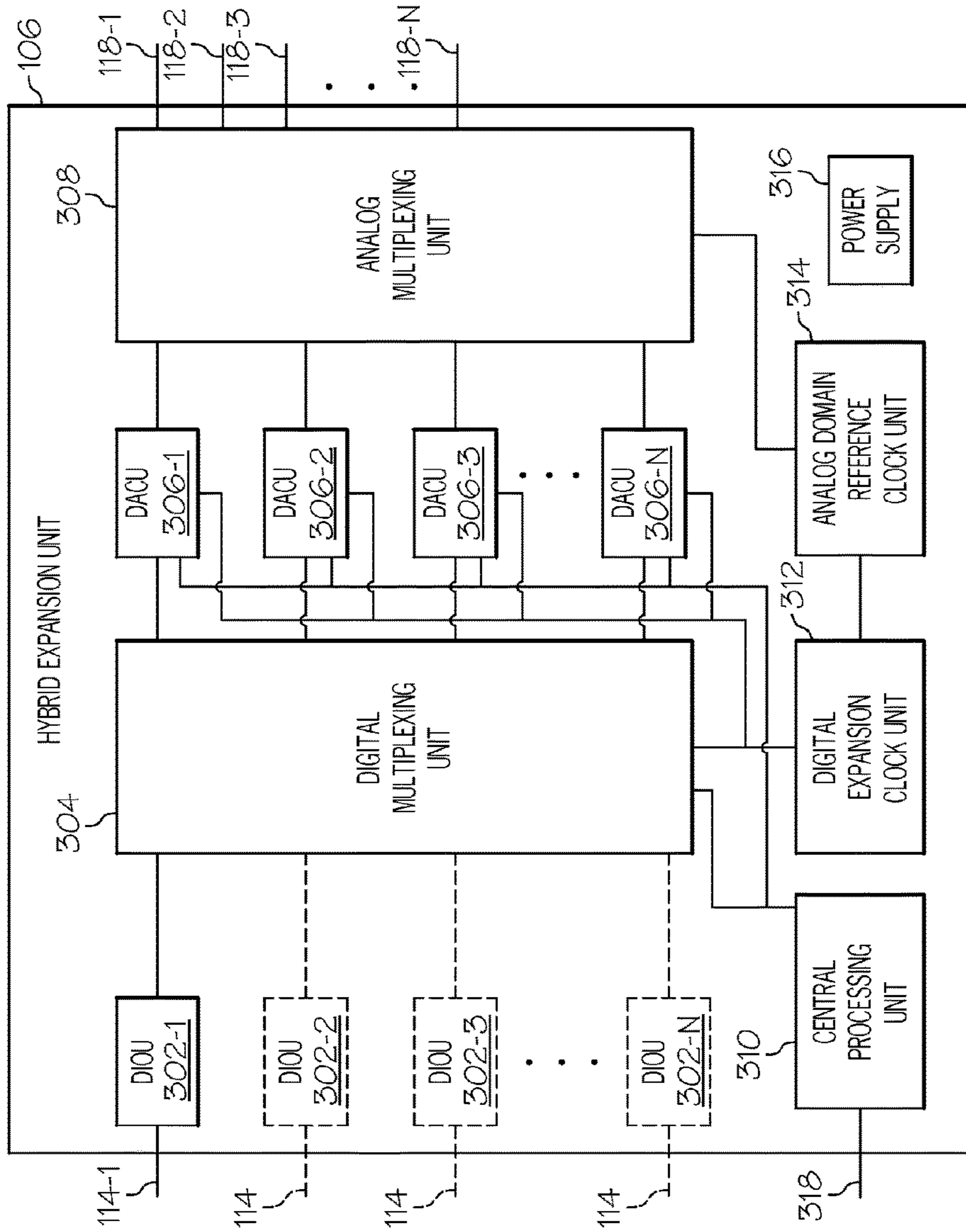

FIG. 3

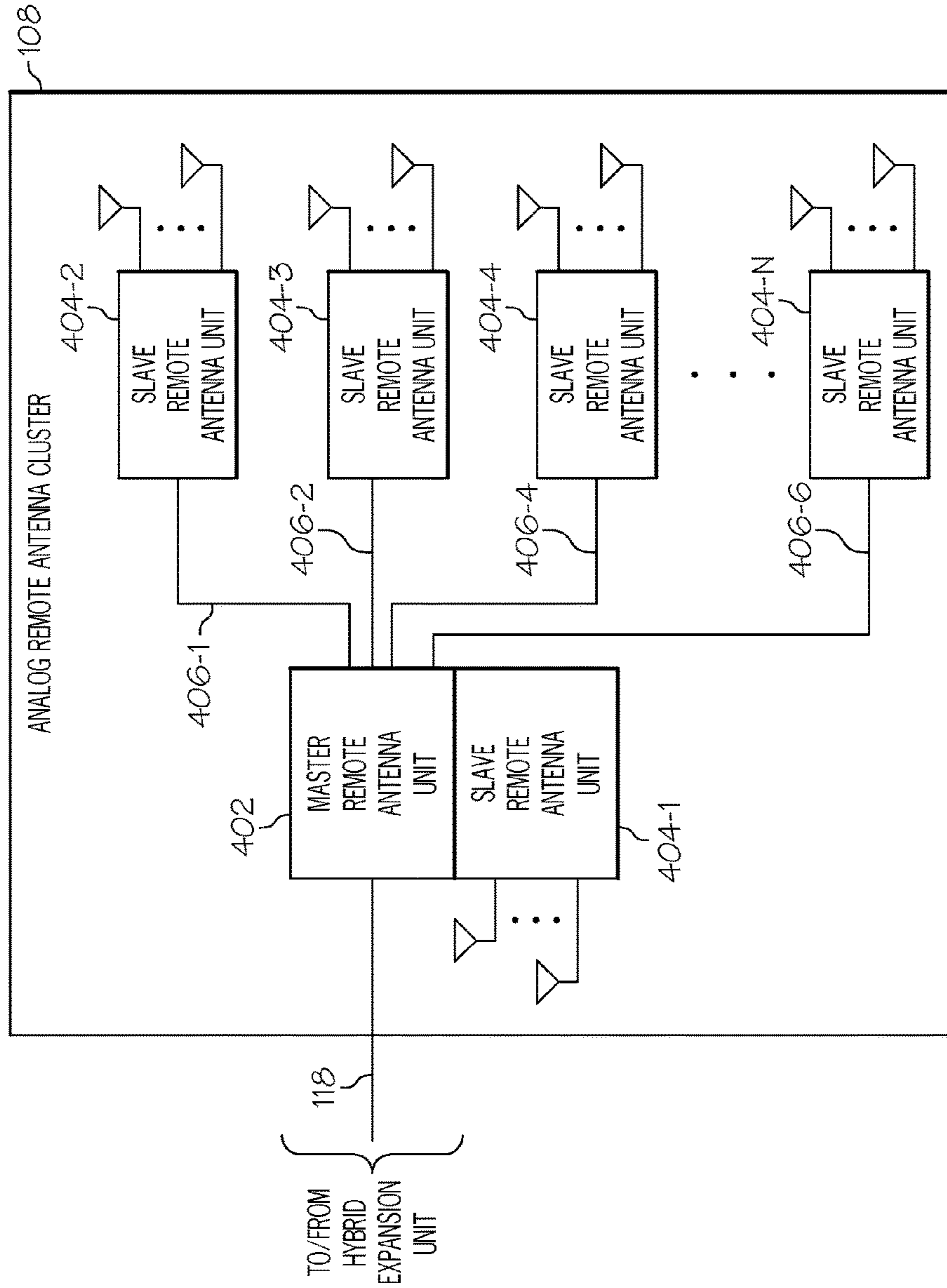

FIG. 4

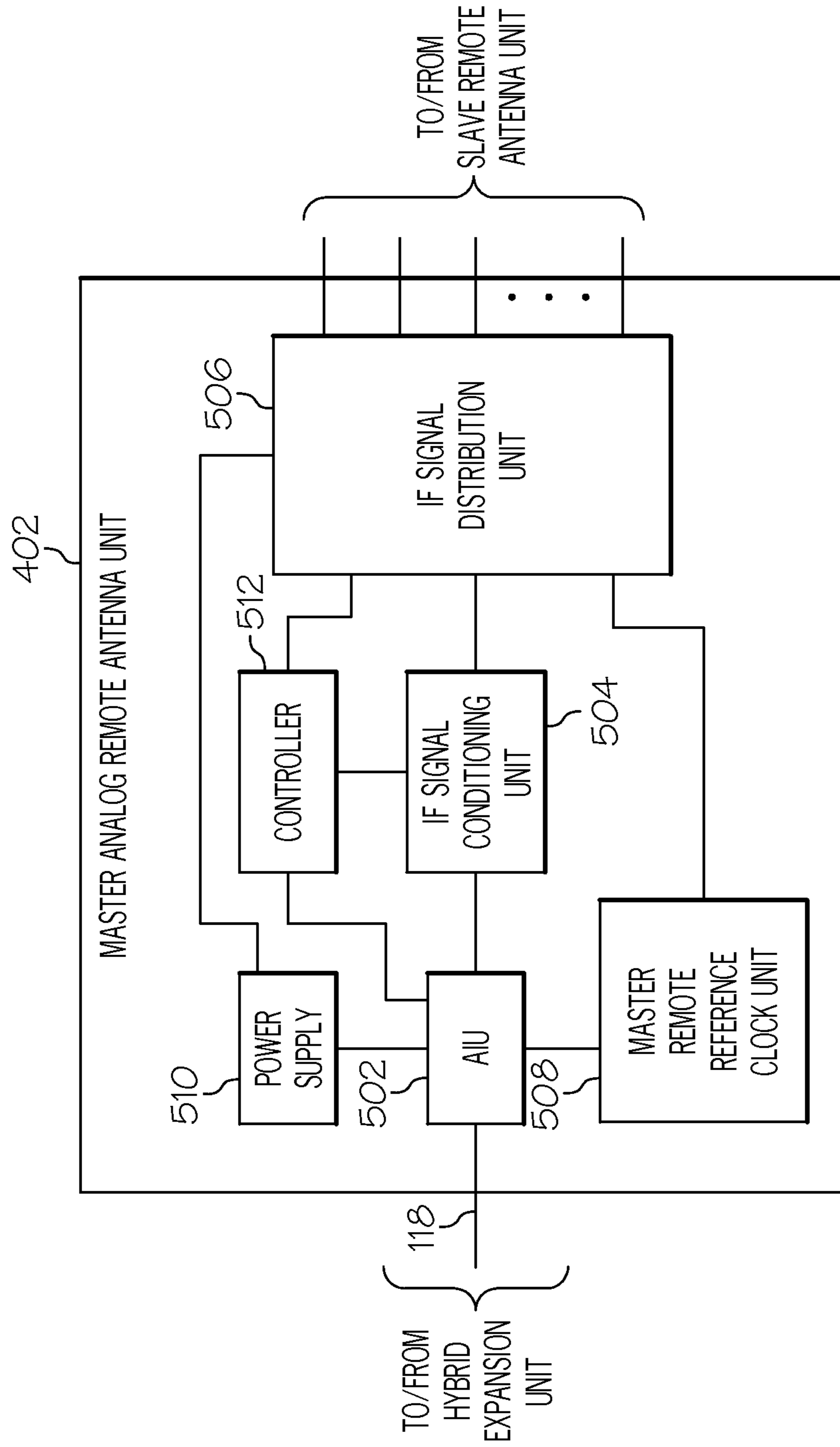

FIG. 5

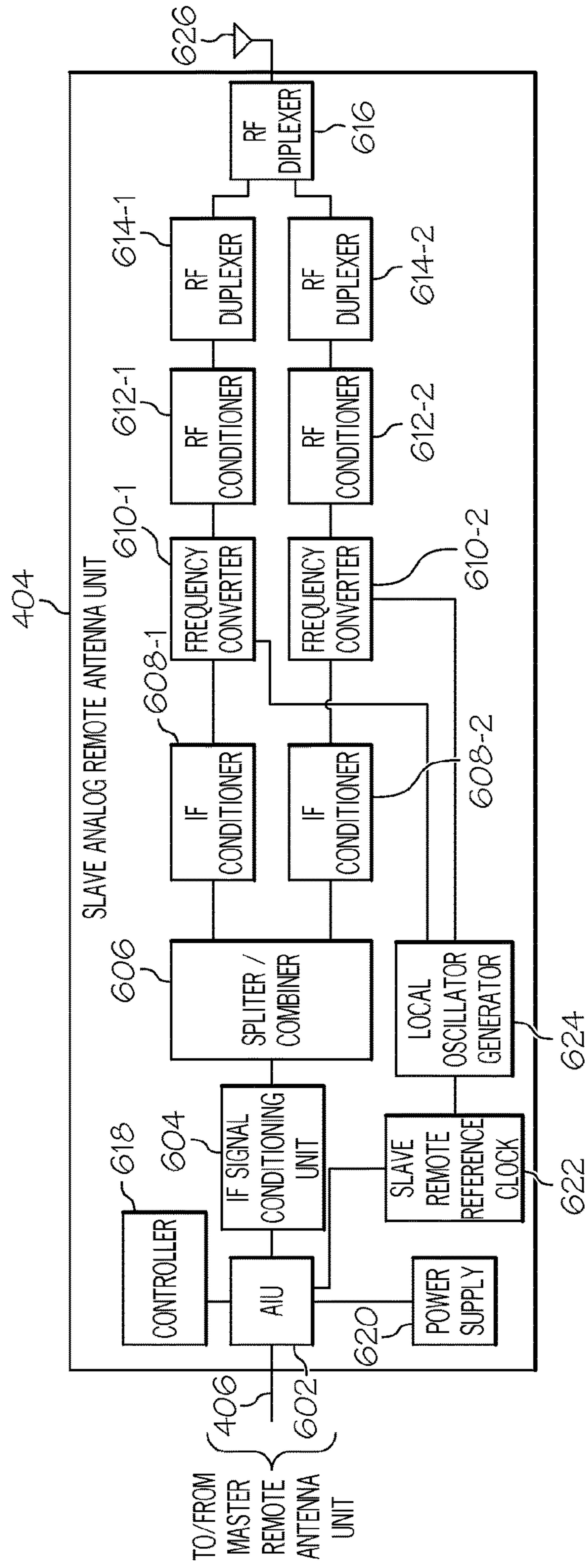

FIG. 6

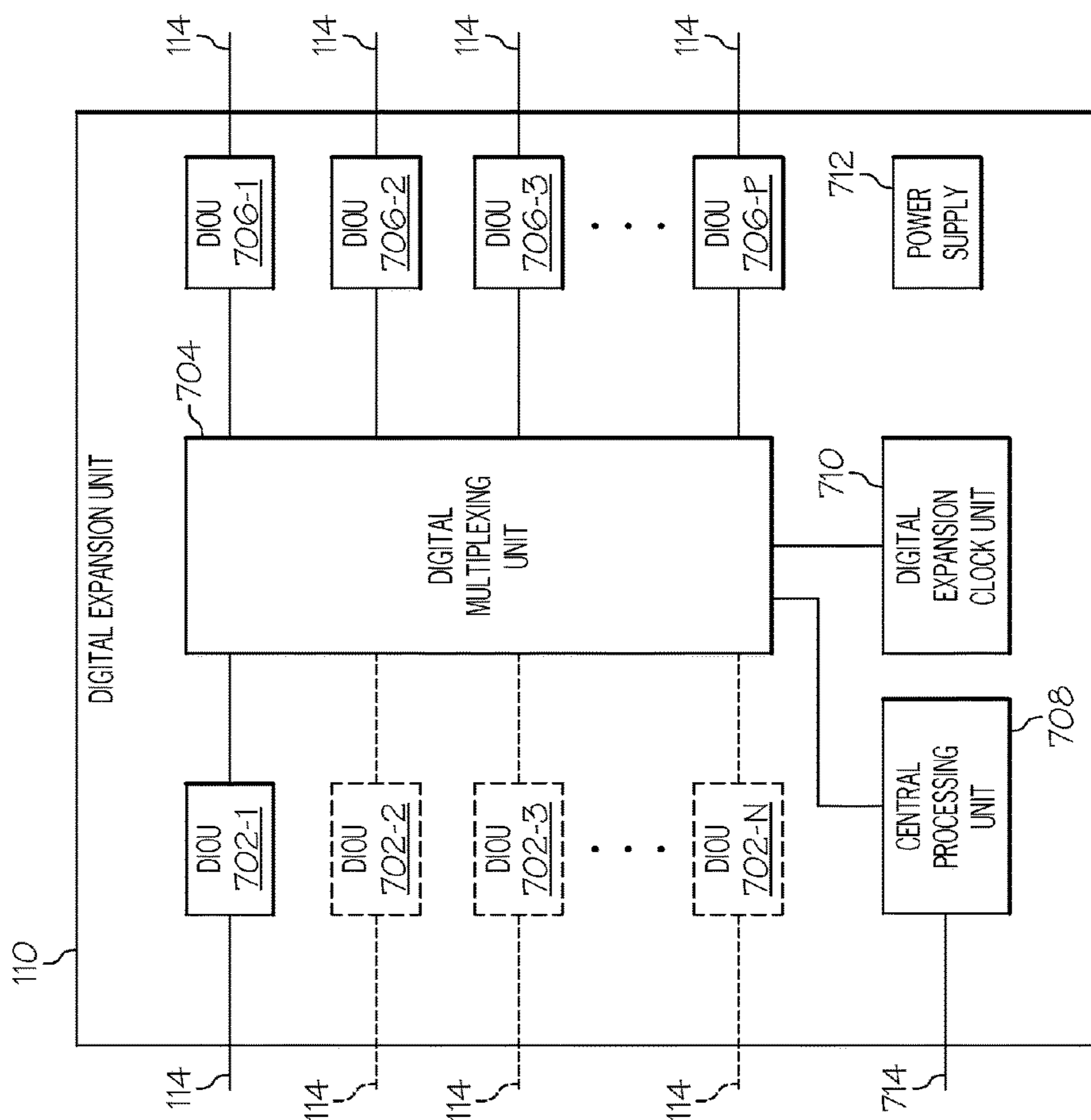

FIG. 7

## DISTRIBUTED DIGITAL REFERENCE CLOCK

**Matter enclosed in heavy brackets [ ] appears in the original patent but forms no part of this reissue specification; matter printed in italics indicates the additions made by reissue; a claim printed with strikethrough indicates that the claim was canceled, disclaimed, or held invalid by a prior post-patent action or proceeding.**

### CROSS-REFERENCE TO RELATED APPLICATIONS

*This Reissue Application is a reissue of application Ser. No. 13/914,838, filed Jun. 11, 2013, which issued as U.S. Pat. No. 8,837,659.* The present application is a continuation application of U.S. patent application Ser. No. 12/845,060 (hereafter "the '060 Application") entitled "DISTRIBUTED DIGITAL REFERENCE CLOCK", filed on Jul. 28, 2010 (currently pending). The present application is also related to commonly assigned and co-pending U.S. patent application Ser. No. 11/150,820 (hereafter "the '820 Application") entitled "PROVIDING WIRELESS COVERAGE INTO SUBSTANTIALLY CLOSED ENVIRONMENTS", filed on Jun. 10, 2005 (currently pending). The present application is also related to commonly assigned and co-pending U.S. patent application Ser. No. 12/775,897 (hereafter "the '897 Application") entitled "PROVIDING WIRELESS COVERAGE INTO SUBSTANTIALLY CLOSED ENVIRONMENTS", filed on May 7, 2010 (currently pending). The '060 Application, '820 Application, and the '897 Application are incorporated herein by reference in their entirety.

### BACKGROUND

Distributed Antenna Systems (DAS) are used to distribute wireless signal coverage into buildings or other substantially closed environments. For example, a DAS may distribute antennas within a building. The antennas are typically connected to a radio frequency (RF) signal source, such as a service provider. Various methods of transporting the RF signal from the RF signal source to the antennas have been implemented in the art.

### SUMMARY

A communication system includes a master host unit, a hybrid expansion unit coupled to the master host unit by a communication link, and a remote antenna unit coupled to the hybrid expansion unit by an analog communication medium. The master host unit is adapted to communicate analog signals with service provider interfaces using a first set of bands of analog spectrum. The master host unit and the hybrid expansion unit are adapted to communicate N-bit words of digitized spectrum over the communication link. The hybrid expansion unit is further adapted to convert between the N-bit words of digitized spectrum and a second set of bands of analog spectrum. The hybrid expansion unit and the remote antenna unit are adapted to communicate the second set of bands of analog spectrum over the analog communication medium. The remote antenna unit is further adapted to transmit and receive wireless signals over air interfaces. The master host unit includes a master clock distribution unit. The master clock distribution unit is adapted to generate a digital master reference clock signal. The master host unit is further adapted to communicate the

digital master reference clock signal over the communication link. The hybrid expansion unit is further adapted to receive the digital master reference clock signal from the master host unit over the communication link. The hybrid expansion unit is further adapted to generate an analog reference clock signal based on the digital master reference clock signal. The hybrid expansion unit is further adapted to send the analog reference clock signal across the analog communication medium. The remote antenna unit is further adapted to receive the analog reference clock signal across the analog communication medium.

### DRAWINGS

FIG. 1 is a block diagram of one embodiment of a system for providing wireless coverage into a substantially enclosed environment.

FIG. 2 is a block diagram of one embodiment of a master host unit for the system of FIG. 1.

FIG. 3 is a block diagram of one embodiment of a hybrid expansion unit for the system of FIG. 1.

FIG. 4 is a block diagram of one embodiment of an analog remote antenna cluster for the system of FIG. 1.

FIG. 5 is a block diagram of one embodiment of a master analog remote antenna unit for the analog remote antenna unit cluster of FIG. 4.

FIG. 6 is a block diagram of one embodiment of a slave analog remote antenna unit for the analog remote antenna unit cluster of FIG. 4.

FIG. 7 is a block diagram of one embodiment of a digital expansion unit for the system of FIG. 1.

### DETAILED DESCRIPTION

FIG. 1 is block diagram of one embodiment of a system **100** for providing wireless coverage into a substantially enclosed environment. The system **100** includes at least one service provider interface **102**, at least one master host unit (MHU) **104**, at least one hybrid expansion unit (HEU) **106**, and at least one analog remote antenna cluster (ARAC) **108**. Specifically, example system **100** includes hybrid expansion unit **106-1** and hybrid expansion unit **106-2** though hybrid expansion unit **106-N**. In addition, example system **100** includes analog remote antenna clusters **108-1** through **108-M**, **108-N** through **108-P**, and **108-Q** through **108-R**. Example system **100** also includes at least one digital expansion unit (DEU) **110**. Other example systems include greater or fewer service provider interfaces **102**, master host units **104**, hybrid expansion units **106**, analog remote antenna clusters **108**, and digital expansion units **110**.

Service provider interface **102** may include an interface to one or more of a base transceiver station (BTS), a repeater, a bi-directional amplifier, a base station hotel or other appropriate interface for one or more service provider networks. In one embodiment, service provider interface **102** provides an interface to a plurality of services from one or more service providers. The services may operate using various wireless protocols and in various bands of frequency spectrum. For example, the services may include, but are not limited to, 800 MHz cellular service, 1.9 GHz Personal Communication Services (PCS), Specialized Mobile Radio (SMR) services, Enhanced Special Mobile Radio (ESMR) services at both 800 MHz and 900 MHz, 1800 MHz and 2100 MHz Advanced Wireless Services (AWS), 700 MHz uC/ABC Single Input Single Output (SISO) and Multiple Input Multiple Output (MIMO) services, two way paging services, video services, Public Safety (PS) services at 450

MHz, 900 MHz and 1800 MHz Global System for Mobile Communications (GSM), 2100 MHz Universal Mobile Telecommunications System (UMTS), Worldwide Interoperability for Microwave Access (WiMAX), 3rd Generation Partnership Projects (3GPP) Long Term Evolution (LTE), or other appropriate communication services.

In system **100**, service provider interface **102** is connected to master host unit **104** over at least one analog communication link **112**. Each analog communication link **112** includes two analog communication media, such as coaxial cables or fiber optic cables. One analog communication media is for downstream communication and the other is for upstream communication. The downstream and upstream analog communication media have been shown as a single analog communication link **112** for simplicity. In other embodiments, each analog communication link **112** only includes a single physical media, which is used to carry both the downlink and uplink streams between the service provider interface **102** and the master host unit **104**.

The master host unit **104** receives downstream bands of radio frequency (RF) spectrum from the at least one service provider interface **102** over the at least one analog communication link **112**. In addition, the master host unit **104** sends upstream bands of radio frequency (RF) spectrum to the at least one service provider interface **102** over the at least one analog communication link **112**. In other embodiments, the service provider interface **102** and the master host unit **104** are connected over at least one digital communication link using at least one digital communication media. In some embodiments, separate analog communications links **112** are used for each service provider interface **102**. Thus, while this disclosure describes at least one analog communication link **112**, the format of this interface is not essential to operation of system **100**. If an analog interface is used, the master host unit **104** converts the analog signal to a digital format as described below. If a digital interface is used, the master host unit **104** will either communicate the digital data as is or reformat the data into a representation that can be used for transport within the digital domain **116** described below. In example embodiments using a single physical medium for each analog communication link **112**, frequency division multiplexing (FDM), time division multiplexing (TDM), and optical wavelength division multiplexing (WDM) are used to achieve a duplex connection over the single medium.

System **100** uses both digital and analog transport to extend the coverage of the wireless services into the substantially enclosed environment. First, system **100** uses digital transport over at least one digital communication link **114** to transport digitized RF spectrum between the master host unit **104** and the at least one hybrid expansion unit **106** and between the master host unit **104** and the at least one digital expansion unit **110**. Each digital communication link **114** includes two digital communication media, such as fiber optic cables. One digital communication medium is for downstream communication and the other is for upstream communication. The downstream and upstream digital communication media have been shown as a single digital communication link **114** for simplicity. The areas of digital transport are called the digital domain **116**. In other implementations, digital transport can be used to transport between other components as well and the digital domain **116** is more expansive. In other embodiments, each digital communication link **114** only includes a single physical media, which is used to carry both the downlink and uplink streams between the master host unit **104** and the at least one digital expansion unit **110**. In example embodiments using a single physical media for each digital communication link

**114**, optical multiplexing techniques (i.e., wavelength division multiplexing (WDM), coarse wavelength division multiplexing (CWDM), or dense wavelength division multiplexing (DWDM)) are used to achieve a duplex connection over the single medium.

While an optical fiber is used in the example system **100**, other appropriate communication media can also be used for the digital transport. For example, other embodiments use free space optics, high speed copper or other wired, wireless, or optical communication media for digital transport instead of the optical fibers used in each of the at least one digital communication link **114**. By using digital transport over the at least one digital communication link **114**, the bands of RF spectrum provided by the service provider interface **102** can be transported over long distances with minimal errors and more resiliency and robustness to signal loss and distortion of the physical medium. Thus, system **100** may extend coverage for wireless services to buildings located significant distances from the service provider interface **102**.

Second, system **100** uses analog transport over at least one analog communication link **118** between the at least one hybrid expansion unit **106** and the at least one analog remote antenna cluster **108** to extend the reach of the digital transport into the substantially enclosed environment. Each analog communication link **118** includes two analog communication media, such as coaxial cable. One analog communication media is for downstream communication and the other is for upstream communication. The downstream and upstream analog communication media have been shown as a single analog communication link **118** for simplicity. While coaxial cable is used in the example system **100**, other appropriate communication media can also be used for the analog transport. The areas of analog transport are called the analog domain **120**. In other implementations, analog transport can be used to transport between other components as well and the analog domain **120** is more expansive. In other embodiments, each analog communication link **118** only includes a single physical medium, which is used to carry both the downlink and uplink streams between each hybrid expansion unit **106** and each analog remote antenna cluster **108**. In example embodiments using a single physical medium for each analog communication link **118**, frequency division multiplexing (FDM), time division multiplexing (TDM), and optical wavelength division multiplexing (WDM) are used to achieve a duplex connection over the single medium.

As discussed in further detail below, the various components of system **100** convert the various bands of RF spectrum between radio frequencies (RF), various intermediate frequencies (IF), digitized bands of RF spectrum, and digitized IF. As baseband representations of the signals can also be used, the invention can be generalized to convert between analog and digital signals. These various conversions require that the digital domain **116** and the analog domain **120** be synchronized in time and frequency. Time synchronization is important to the sampling and reconstruction of the signals. Time synchronization is also important when time alignment of signals in the various parallel branches of the system is necessary. Frequency synchronization is important to maintaining the absolute frequency of the signals at the external interfaces of the system. In order to synchronize the digital domain **116** and the analog domain **120**, a common reference clock is distributed throughout both the digital domain **116** and the analog domain **120** as described in detail below. This common clock allows for accurate conversion and recovery between RF, IF, digitized

bands of RF spectrum, and digitized IF, or more broadly between analog spectrum and digital spectrum.

FIG. 2 is a block diagram of one embodiment of the Master host unit **104** of system **100**. Master host unit **104** includes at least one digital-analog conversion unit (DACU) **202**, at least one digital multiplexing unit (DMU) **204**, at least one digital input-output unit (DIOU) **206**, at least one central processing unit (CPU) **208**, at least one master clock distribution unit (MCDU) **210**, and at least one power supply **212**. In addition, the example master host unit **104** also includes at least one splitter/combiner **214**.

The master host unit **104** communicates at least one band of analog spectrum with the at least one service provider interface **102**. In the example system **100**, there are a plurality of service provider interfaces **102-1**, **102-2**, **102-3**, through **102-N**. In addition, there are a plurality of DACUs **202-1**, **202-2**, **202-3**, through **202-N**. Each DACU **202** is coupled with at least one service provider interface **102**. These couplings may be accomplished in various ways. For example, service provider interface **102-1** is directly coupled to DACU **202-1** through analog communication link **112-1**. In contrast, service provider interface **102-2** is coupled to a first side of splitter/combiner **214-1** through analog communication link **112-2**, DACU **202-2** is coupled to a second side of splitter/combiner **214-1** through analog communication link **112-3**, and DACU **202-3** is coupled to the second side of splitter/combiner **214-1** through analog communication link **112-4**. In addition, service provider interface **102-3** is coupled to a first side of splitter/combiner **214-2** through analog communication link **112-5**, service provider interface **102-N** is coupled to the first side of splitter/combiner **214-2** through analog communication link **112-6**, and DACU **202-N** is coupled to a second side of splitter/combiner **214-2** through analog communication link **112-7**. As noted above, each analog communication link **112** of system **100** represents two analog media, one for downstream communication and one for upstream communication. In other embodiments, each link includes greater or fewer analog medium. In other embodiments, the master host unit communicates at least one band of digital spectrum with at least one service provider interface across at least one digital communication link using digital data or digitized spectrum. In these embodiments, the signals from the service provider interfaces **102-1**, **102-2**, **102-3**, through **102-N** are first converted from analog to digital before being transmitted across the at least one digital communication link to the master host unit **104**.

Each DACU **202** operates to convert between at least one band of analog spectrum and N-bit words of digitized spectrum. In some embodiments, each DACU **202** is implemented with a Digital/Analog Radio Transceiver (DART board) commercially available from ADC Telecommunications, Inc. of Eden Prairie, Minn. as part of the FlexWave™ Prism line of products. The DART board is also described in U.S. patent application Ser. No. 11/627,251, assigned to ADC Telecommunications, Inc., published in U.S. Patent Application Publication No. 2008/0181282, and incorporated herein by reference. In some implementations, this occurs in stages, such that the analog spectrum is first converted to an IF frequency and subsequently converted to N-bit words of digitized spectrum. The bands of analog spectrum include signals in the frequency spectrum used to transport a wireless service, such as any of the wireless services described above. In some embodiments, master host unit **104** enables the aggregation and transmission of a plurality of services to a plurality of buildings or other

structures so as to extend the wireless coverage of multiple services into the structures with a single platform.

The DMU **204** multiplexes N-bit words of digitized spectrum received from a plurality of DACU **202** (DACU **202-1** through DACU **202-N**) and outputs at least one multiplexed signal to at least one DIOU **206** (DIOU **206-1** through DIOU **206-N**). The DMU **204** also demultiplexes at least one multiplexed signal received from at least one DIOU **206** and outputs demultiplexed N-bit words of digitized spectrum to a plurality of DACU **202**. In some embodiments, each DMU **204** is implemented with a Serialized RF (SeRF board) commercially available from ADC Telecommunications, Inc. of Eden Prairie, Minn. as part of the FlexWave™ Prism line of products. The SeRF board is also described in U.S. patent application Ser. No. 11/627,251, assigned to ADC Telecommunications, Inc., published in U.S. Patent Application Publication No. 2008/0181282, and incorporated herein by reference.

Each DIOU **206** communicates at least one digitized multiplexed signal across at least one digital communication link **114** (digital communication link **114-1** through digital communication link **114-N**) using digital transport. The digitized multiplexed signal communicated across the digital communication link **114** includes N-bit words of digitized spectrum. Each DIOU **206** also receives at least one digitized multiplexed signal from the at least one digital communication link **114** using digital transport and sends the at least one digitized multiplexed signal to the DMU **204**. In system **100** shown in FIG. 1, the digital communication link **114-1** is connected to hybrid expansion unit **106-1** and digital communication link **114-N** is connected to digital expansion unit **110**. DIOU **206-1** communicates using digital transport with hybrid expansion unit **106-1** and DIOU **206-N** communicates using digital transport with digital expansion unit **110**. As noted above, each digital communication link **114** represents two digital media, one for downstream communication and one for upstream communication. In addition to carrying the digitized multiplexed signals, the digital communication link **114** is also used to communicate other types of information such as system management information, control information, configuration information and telemetry information. The hybrid expansion unit **106** and digital expansion unit **110** are described in detail below.

Each DACU **202** and DMU **204** is synchronized with the other components of master host unit **104** and system **100** generally. Master clock distribution unit **210** generates a digital master reference clock signal. This signal is generated using any stable oscillator, such as a temperature compensated crystal oscillator (TCXO), an oven controlled crystal oscillator (OCXO), or a voltage controlled crystal oscillator (VCXO). In the embodiment shown in FIG. 2, the stable oscillator is included in the master clock distribution unit **210**. In other embodiments, a reference clock external to the master host unit is used, such as a clock from a base station, a GPS unit, or a cesium atomic clock. In embodiments where digital data is communicated between service provider interface **102** and master host unit **104**, the master clock distribution unit **210** may derive the reference clock signal from the digital data stream itself or an external clock signal may be used.

The digital master reference clock signal is supplied to each DACU **202** and each DMU **204** in the master host unit **104**. Each DACU **202** uses the clock to convert between at least one band of analog spectrum and N-bit words of digitized spectrum. The DMU **204** uses the clock to multiplex the various streams of N-bit words of digitized spec-



trum together and outputs the multiplexed signal to each DIOU 206. Thus, the downstream digital data streams output by each DIOU 206 are synchronized to the digital master reference clock signal. Thus, through the clocking of the downstream digital data streams, the digital master reference clock signal is distributed to each hybrid expansion unit 106 and each digital expansion unit 110 through each corresponding digital communication link 114.

CPU 208 is used to control each DACU 202 and each DMU 204. An input/output (I/O) line 216 coupled to CPU 208 is used for network monitoring and maintenance. Typically, I/O line 216 is an Ethernet port used for external communication with the system. Other communication protocols such as Universal Serial Bus (USB), IEEE 1394 (FireWire), and serial may also be used. Power supply 212 is used to power various components within master host unit 104.

FIG. 3 is a block diagram of one embodiment of a hybrid expansion unit 106 of system 100. Hybrid expansion unit 106 of system 100 includes at least one digital input-output unit (DIOU) 302, at least one digital multiplexing unit (DMU) 304, at least one digital-analog conversion unit (DACU) 306, at least one analog multiplexing unit (AMU) 308, at least one central processing unit (CPU) 310, at least one digital expansion clock unit (DECU) 312, at least one analog domain reference clock unit (ADRCU) 314, and at least one power supply 316.

Each hybrid expansion unit 106 communicates at least one band of digitized spectrum with the master host unit 104 in the form of a multiplexed digitized signal containing N-bit words of digitized spectrum. The multiplexed digitized signal is received at the at least one DIOU 302 through at least one digital communication link 114. In the embodiment shown in FIG. 3, only one DIOU 302-1 is necessary if the hybrid expansion unit 106 is only coupled with a single upstream master host unit 104 (or single upstream digital expansion unit 110 as described in detail below). DIOU 302-2 through DIOU 302-N are optional. For example, in other embodiments, hybrid expansion unit 106 has multiple DIOUs 302 (DIOU 302-1 through DIOU 302-N) and is connected to multiple upstream master host units 104 or digital expansion units 110 through digital communication links 114. In other embodiments, hybrid expansion unit 106 is connected to other hybrid expansion units through DIOU 302. In some embodiments including multiple upstream connections, the hybrid expansion unit 106 selects one DIOU 302 to extract the clock signal from.

The at least one DIOU 302 communicates the multiplexed digitized signal containing N-bit words of digitized spectrum to the DMU 304. The DMU 304 demultiplexes N-bit words of digitized spectrum received from the at least one DIOU 302 and sends N-bit words of digitized spectrum to the at least one DACU 306. The at least one DACU 306 converts the N-bit words of digitized spectrum to at least one band of analog spectrum. In some embodiments, the at least one DACU 306 converts the digitized signal back to the original analog frequency provided by the at least one service provider interface 102. In other embodiments, the at least one DACU 306 converts the digitized signal to an intermediate frequency (IF) for transport across the at least one analog communication link 118. In other embodiments, other components are included in the hybrid expansion unit 106 that frequency convert at least one band of analog spectrum output by the DACU 306 into an intermediate frequency for transport.

Each DACU 306 is coupled with the AMU 308. Each DACU 306 also converts at least one band of analog

spectrum received from the AMU 308 into N-bit words of digitized spectrum. AMU 308 receives multiple bands of analog spectrum from multiple DACU 306 and multiplexes the bands of analog spectrum together into at least one multiplexed analog signal including multiple bands of analog spectrum. In some embodiments, there are a plurality of multiplexed analog signals output from the AMU 308. In some embodiments, all of the bands of analog spectrum from each DACU 306 are included on each multiplexed signal output by AMU 308. In other embodiments, a subset of the bands of analog spectrum from a plurality of DACU 306 are multiplexed onto one signal output on one of the at least one analog communication link 118, while a different subset of bands of analog spectrum from a plurality of DACU 306 are multiplexed onto another signal output on another of the at least one analog communication link 118. In other embodiments, different combinations of bands of analog spectrum from various DACU 306 are multiplexed onto various analog communication links 118.

In some embodiments, each DACU 306 converts a band of digitized spectrum to a different analog frequency from the other DACU 306. Each band of analog spectrum is pre-assigned to a particular analog frequency. Then, the AMU 308 multiplexes the various pre-assigned analog frequencies together, in addition to the analog domain reference clock and any communication, control, or command signals and outputs them using at least one analog communication link 118. In other embodiments, each DACU 306 converts a band of analog spectrum to the same analog frequency as the other DACU 306. Then, the AMU 308 shifts the received signals into distinct analog frequencies and multiplexes them together and outputs them using at least one analog communication link 118. In the embodiment shown in FIG. 3, the AMU 308 multiplexes the analog frequencies received from each DACU 306 onto each analog communication link 118.

In other embodiments, bands of frequency spectrum from certain DACU 306 are selectively distributed to certain analog communication links 118. In one example embodiment, analog communication link 118-1 is coupled to analog remote antenna cluster 108-1 and only a first subset of bands of analog spectrum are transported using analog communication link 118-1. Further, analog communication link 118-2 is coupled to analog remote antenna cluster 108-2 and only a second subset of bands of analog spectrum are transported using analog communication link 118-2. In another embodiment, a first subset of bands of analog spectrum are transported to analog remote antenna cluster 108-1 using analog communication link 118-2 and a second subset of bands of analog spectrum are transported to the same remote cluster 108-1 using analog communication link 118-1. It is understood that these examples are not limiting and that other system hierarchies and structures are used in other embodiments.

Each DMU 304, DACU 306, and AMU 308 is synchronized with the other components of hybrid expansion unit 106 and system 100 generally. In the example embodiment shown in FIG. 3, DIOU 302-1 receives the data stream from a master host unit 104 via a digital communication link 114 in an optical format. DIOU 302-1 converts the data stream from the optical format to an electrical format and passes the data stream onto the DMU 304. The DMU 304 extracts the digital master reference clock signal from the data stream itself. Because the data stream was synchronized with the digital master reference clock signal at the master host unit 104, it can be recovered from the data stream itself. The extracted digital master reference clock signal is sent to the

digital expansion clock unit **312**. Each DIOU **302** is not required to be synchronized to the other parts of the hybrid expansion unit unless it performs some type of function that requires it to be synchronized. In one embodiment, the DIOU **302** performs the extraction of the digital master reference clock in which case it would be synchronized to the remainder of the hybrid expansion unit.

The digital expansion clock unit **312** receives the digital master reference clock signal extracted from the data stream received from the master host unit **104**. The digital expansion clock unit **312** communicates the digital master reference clock signal to various components of the hybrid expansion unit **106**, including the DMU **304** and each DACU **306**. Each DMU **304** and DACU **306** uses the digital master reference clock signal to synchronize itself with the system **100**. In other embodiments, the digital expansion clock unit **312** could receive a copy of the data stream from the DMU **304** and extract the digital master reference clock signal from the data stream itself. In some embodiments, each DIOU **302** is selectable and configurable, so that one DIOU **302** can be selected to receive the digital master reference clock signal and other DIOUs **302** can be used to send the digital master reference clock signal upstream to other system components, such as secondary master host units, digital expansion units, or other hybrid expansion units.

In addition, the digital expansion clock unit **312** distributes the digital master reference clock signal to the analog domain reference clock unit **314**. The analog domain reference clock unit **314** in turn generates an analog domain reference clock signal based on the digital master reference clock signal. This analog domain reference clock signal is used to synchronize analog components in the hybrid expansion unit **106**, such as analog frequency conversion functions in the AMU **308**. In addition, the AMU multiplexes the analog domain reference clock signal onto the multiplexed signals sent on each analog communication link **118** to the at least one analog remote antenna cluster **108**.

In the embodiment of hybrid expansion unit **106** shown in FIG. **3**, the analog domain reference clock unit **314** generates the analog domain reference clock signal by running the digital master reference clock signal through a phase locked loop circuit. In some embodiments, the digital master reference clock signal is approximately 184.32 MHz and the analog domain reference clock signal is generated as a 30.72 MHz clock based on the 184.32 MHz digital master reference clock signal. Thus, the 30.72 MHz clock is multiplexed onto the multiplexed signals sent on each analog communication link **118** to at least one analog remote antenna cluster **108**.

CPU **310** is used to control each DMU **304** and each DACU **306**. An input/output (I/O) line **318** coupled to CPU **310** is used for network monitoring and maintenance. Typically, I/O line **318** is an Ethernet port used for external communication with the system. Power supply **316** is used to power various components within hybrid expansion unit **106**.

In addition to performing the analog frequency conversion functions described above, the AMU **308** couples power onto the analog communication link **118**. This power is then supplied through the analog communication link **118** to the downstream remote antenna cluster **108**, including master remote antenna unit **402** and slave remote antenna units **404-1** as described below. The power coupled onto the analog communication link **118** is supplied from the power supply **316**. In the example embodiment shown, 28 volts DC

is received by AMU **308** from the power supply **316** and is coupled to the analog communication link **118** by AMU **308**.

In the embodiments described and depicted in FIGS. **4-6**, the term analog intermediate frequency (IF) spectrum is used to describe the analog signals transported in the analog domain **120** between the hybrid expansion units **106** and the analog remote antenna clusters **108**. The term analog IF spectrum is used to distinguish the signals from the analog RF spectrum format that is communicated to the service provider interface and the mobile devices over the air. Example system **100** uses analog IF spectrum for transport within the analog domain **120** that is lower in frequency than the analog RF spectrum. In other example embodiments, the RF spectrum can be transmitted at its native frequency within the analog domain **120** or using an analog IF spectrum that is higher in frequency than the analog RF spectrum.

FIG. **4** is a block diagram of one embodiment of an analog remote antenna cluster **108** for system **100**. Analog remote antenna cluster **108** includes a master analog remote antenna unit **402** and a plurality of slave analog remote antenna units **404-1** through **404-N**. In other embodiments, other configurations are used instead of this master/slave configuration.

In example analog remote antenna cluster **108**, the master analog remote antenna unit **402** is coupled to at least one analog communication link **118**. In the embodiment shown in FIG. **4**, the at least one coaxial cable includes two coaxial cables. A first coaxial cable is used to transport downstream communication from a hybrid expansion unit **106** and the analog remote cluster **108**, including the bands of downstream analog spectrum associated with the service providers. A second coaxial cable is used to transport upstream communication from the analog remote cluster **108** to the hybrid expansion unit **106**, including the bands of upstream analog spectrum associated with the service providers. The downstream analog spectrum and the upstream analog spectrum are transported on separate coaxial cables in this example embodiment due to bandwidth limitations of the coaxial cable being used as media. In other example embodiments, a single analog communication link **118** is used to transport both the downstream and upstream analog spectrum. In other example embodiments, the at least one analog communication link **118** includes greater than two coaxial cables in order to transport even more bands. In other example embodiments, different media such as twisted pair (i.e., unshielded twisted pair (UTP) or screened unshielded twisted pair (ScTP)), CATV fibers, or optical fibers are used to transport the analog signals instead of coaxial cables.

In example analog remote antenna cluster **108**, the master analog remote antenna unit **402** coordinates the distribution of various bands of analog RF spectrum to various slave analog remote antenna units **404** through analog communication links **406**. The master analog remote antenna unit **402** is discussed in further detail below. In the example analog remote antenna cluster **108**, each slave analog remote antenna unit **404-1** through **404-N** receive at least one band of analog RF spectrum from the master remote antenna unit. Each slave analog remote antenna unit **404-1** through **404-N** then transmits and receives the at least one band of analog RF spectrum wirelessly across an air medium using at least one antenna. The slave analog remote antenna unit **404** is discussed in further detail below.

FIG. **5** is a block diagram of one embodiment of a master analog remote antenna unit **402** from the analog remote antenna cluster **108**. Master analog remote antenna unit **402** includes an analog interface unit (AIU) **502**, an IF signal conditioning unit **504**, an IF signal distribution unit **506**, a

## 11

master remote reference clock **508**, a power supply **510**, and a controller **512**. Other example embodiments of master analog remote antenna unit include greater or fewer components.

The at least one analog communication link **118** is connected to the master analog remote antenna unit **402** through the AIU **502**. One of the primary functions of the AIU is to handle any type of media conversion that may be necessary which in some embodiments may involve impedance transformation. Specifically, in the example embodiment shown in FIG. **5**, the AIU **502** performs impedance conversion from the 75 ohms of the coaxial cables carrying the downstream and upstream bands of analog spectrum to the 50 ohms used within the master analog remote antenna unit **402**. The AIU **502** also includes a coupler that is used to extract the DC power received from the hybrid expansion unit **106** across the at least one analog communication link **118**.

In addition, the analog reference clock signal is extracted from the signal received from the hybrid expansion unit **106** across the at least one analog communication link **118**. This analog reference clock signal is sent to the master remote reference clock unit **508**. Any control signals received from the hybrid expansion unit **106** across the at least one analog communication link **118** are also extracted and sent to the controller **512**.

Power supply **510** receives DC power from the AIU **502** and then generates the necessary DC power for operation of the various components onboard the master analog remote antenna unit **402**. Thus, master analog remote antenna unit **402** does not need a separate power source other than the power that is received across the at least one analog communication link **118**. In the example embodiment shown, 28 volts DC is extracted from the signal received across the at least one analog communication link **118** by the AIU **502**. This 28 volts DC is then used by the power supply **510** to generate 5 volts DC and 12 volts DC to power the various devices in the master analog remote antenna unit. In addition, the power received across the analog communication link **118** is sent by the power supply **510** to the IF signal distribution unit **506** where it is coupled onto the analog communication links **406** that connect to each slave remote antenna unit **404** so that each slave remote antenna units **404** can also derive power from the cable instead of having a separate external power source. Thus, power for both the master analog remote antenna unit **402** and each slave analog remote antenna unit **404** is provided by the hybrid expansion unit **106** through the analog communication links **118** and **406**.

As noted above, the AIU **502** extracts the clock signal and supplies it to the master remote reference clock unit **508**. The master remote reference clock unit **508** refines the original clock signal received from the hybrid expansion unit **106** across the at least one analog communication link **118**. In example embodiments, the master remote reference clock unit **508** processes the clock signal through a phase locked loop to refine the signal. In this way, noise, distortion, and other undesirable elements are removed from the reference clock signal. In other embodiments, the clock signal is processed through a filter to remove adjacent spurious signals. The refined signal output from the master remote reference clock unit **508** is sent to the IF signal distribution unit **506**, where it is coupled onto the outputs of the IF signal distribution unit **506** that are connected to the slave analog remote antenna units **404**. In this way, the master reference clock signal is redistributed by the master analog remote antenna unit **402** to all the slave analog remote antenna units **404**.

## 12

IF signal conditioning unit **504** is configured to remove distortion in the analog IF signals that traverse the analog communication link **118**. In the example master analog remote antenna unit **402** shown in FIG. **5**, IF signal conditioning unit **504** performs cable equalization for signals sent and received across the at least one analog communication link **118**. The at least one analog communication link **118** is generally quite long, causing the gain to vary as a function of frequency. IF signal conditioning unit **504** adjusts for gain at various frequencies to equalize the gain profile. IF signal conditioning unit **504** also performs filtering of the analog IF signals to remove adjacent interferers or spurious signals before the signals are propagated further through the system **100**.

Controller **512** receives control signals from the AIU **502** that are received from hybrid expansion unit **106** across the at least one analog communication link **118**. Controller **512** performs control management, monitoring, and can configure parameters for the various components of the master analog remote antenna unit **402**. In the example master analog remote antenna unit **402**, the controller **512** also drives the cable equalization algorithm.

IF signal distribution unit **506** is used to distribute the signals processed by the IF signal conditioning unit **504** to various slave analog remote antenna units **404** across analog communication links **406-1** through **406-N**. In the example embodiment shown in FIG. **5**, two bands are sent across each analog communication link **406** at two different analog IF frequencies. As noted above, the IF signal distribution unit **506** is also used to couple the DC power, the analog reference clock, and any other communication signals from the master analog remote antenna unit **402** onto analog communication link **406**. The IF signal conditioning occurs at the IF signal conditioning unit **504** before the various analog signals are distributed at the IF signal distribution unit **506** in the embodiment shown in FIG. **5**. In other embodiments, the IF signal conditioning could be done after the distribution of the analog signals.

FIG. **6** is a block diagram of one embodiment of a slave analog remote antenna unit **404** for the analog remote antenna unit cluster **108**. The slave analog remote antenna unit **404** includes an analog interface unit (AIU) **602**, an IF signal conditioning unit **604**, a splitter/combiner **606**, a plurality of IF conditioners **608**, a plurality of frequency converters **610**, a plurality of RF conditioners **612**, a plurality of RF duplexers **614**, and a RF diplexer **616**. While the slave analog remote antenna unit **404** is described as a separate component, in some example embodiments, a slave analog remote antenna unit **404** is integrated with a master analog remote antenna unit **402**.

The AIU **602** is connected to the analog communication link **406**. The AIU **602** includes a coupler that is used to extract the DC power received from the master analog remote antenna unit **402** across the analog communication link **406**. The AIU **602** passes the extracted DC power to the power supply **620**. The power supply **620** in turn powers the various components of the slave analog remote antenna unit **404**. The AIU **602** also extracts control signals received from the master analog remote antenna unit **402** across the analog communication link **406**. The control signals are sent by the AIU **602** to the controller **618**. The controller **618** uses the control signals to control various components of the slave analog remote antenna unit **404**. In particular, the control signals are used by the controller **618** to control the gain in the IF signal conditioning unit **604**. Adjustments may be made based on temperature changes and other dynamic factors. The control signals are also used for the configura-

tion of the subsequent frequency conversion **610** and signal conditioning functions **608** and **612**.

The AIU **602** also extracts the analog reference clock and sends it to the slave remote reference clock unit **622**. In the embodiment shown in FIG. 6, the slave remote reference clock unit **622** refines the reference clock signal using a band pass filter. In other embodiments, the reference clock signal drives a phase locked loop to generate a refined reference clock signal. The slave remote reference clock unit **622** distributes the refined reference clock signal to the local oscillator generator **624**, which generates local oscillator signals for the mixers used for frequency conversion. The local oscillator signals are generated using a phase locked loop. In the example shown in FIG. 6, the local oscillator generator **624** generates four local oscillator frequencies for each of the carrier signals of a first and second band. A first local oscillator frequency is used for downlink data in a first band and a second local oscillator frequency is used for the uplink data in the first band. A third local oscillator frequency is used for the downlink data in a second band and a fourth local oscillator frequency is used for the uplink data in the second band. In other example embodiments, greater or fewer bands are used and greater or fewer local oscillator signals are created by the local oscillator generator **624**. For example, some embodiments may require diversity, so that two uplinks are needed for each downlink and three local oscillators would need to be generated for each band. In example embodiments, the AIU **602** is also used to impedance convert between the signal received on the analog communication link **406** and the signal processed by various components of the slave analog remote antenna unit **404**.

Various analog spectrum received across the analog communication link **406** by the AIU **602** is passed to the IF signal conditioning unit **604**. The IF signal conditioning unit **604** filters out noise, distortion, and other undesirable elements of the signal using amplification and filtering techniques. The IF signal conditioning unit passes the analog spectrum to the splitter/combiner **606**, where the various bands are split out of the signal in the downlink and combined together in the uplink. In the downstream, a first band is split out and passed to the IF conditioner **608-1** and a second band is split out and passed to the IF conditioner **608-2**. In the upstream, a first band is received from the IF conditioner **608-1**, a second band is received from the IF conditioner **608-2**, and the two upstream bands are combined by the splitter/combiner **606**.

In the downstream for band A, IF conditioner **608-1** passes the IF signal for band A to the frequency converter **610-1**. The frequency converter **610-1** receives a downstream mixing frequency for band A from local oscillator generator **624**. The frequency converter **610-1** uses the downstream mixing frequency for band A to convert the downstream IF signal for band A to a downstream RF signal for band A. The downstream RF signal for band A is passed onto the RF conditioner **612-1**, which performs RF gain adjustment and filtering on the downstream RF signal for band A. The RF conditioner **612-1** passes the downstream RF signal for band A to the RF duplexer **614-1**, where the downstream RF signal for band A is combined onto the same medium with an upstream RF signal for band A. Finally, the RF duplexer **616** combines band A and band B together. Thus, both band A and band B are transmitted and received across an air medium using a single antenna **626**. In other embodiments, multiple antennas are used. In one specific embodiment, the RF duplexer **616** is not necessary because band A and band B are transmitted and received using independent antennas. In other embodiments, the down-

stream signals are transmitted from one antenna and the upstream signals are received from another antenna. In embodiments with these types of alternative antenna configurations, the requirements and design of the RF duplexers **614** and the RF duplexers **616** will vary to meet the requirements of the antenna configuration.

In the downstream for band B, IF conditioner **608-2** passes the IF signal for band B to the frequency converter **610-2**. The frequency converter **610-2** receives a downstream mixing frequency for band B from local oscillator generator **624**. The frequency converter **610-2** uses the downstream mixing frequency for band B to convert the downstream IF signal for band B to a downstream RF signal for band B. The downstream RF signal for band B is passed onto the RF conditioner **612-2**, which performs more RF adjustment and filtering on the downstream RF signal for band B. The RF conditioner **612-2** passes the downstream RF signal for band B to the RF duplexer **614-2**, where the downstream RF signal for band B is combined onto the same medium with an upstream RF signal for band B. Finally, the RF duplexer **616** combines band A and band B together as described above, such that both band A and band B are transmitted and received across an air medium using antenna **626**.

In the upstream, antenna **626** receives the RF signal for both band A and band B and passes both onto RF duplexer **616** which separates band A from band B. Then, band A is passed to RF duplexer **614-1**, where the upstream RF and downstream RF signals for band A are separated onto different signal lines. The upstream RF signal for band A is then passed to the RF conditioner **612-1**, which performs gain adjustment and filtering on the upstream RF signal for band A. Finally, the upstream RF signal for band A is passed to frequency converter **610-1**, which frequency converts the upstream RF signal for band A into an upstream IF signal for band A using an upstream mixing frequency generated by the local oscillator generator **624**.

In addition, band B is passed from the RF duplexer **616** to the RF duplexer **614-2**, where the upstream RF and downstream RF signals for band B are separated onto different signal lines. The upstream RF signal for band B is then passed to the RF conditioner **612-1**, which performs gain adjustment and filtering on the upstream RF signal for band B. Finally, the upstream RF signal for band B is passed to frequency converter **610-2**, which frequency converts the upstream RF signal for band B into an upstream IF signal for band B using an upstream mixing frequency generated by the local oscillator generator **624**.

In embodiments where the functions of the master remote antenna unit **402** and the slave remote antenna unit **404-1** are integrated into the same physical package, as depicted in FIG. 4, some of the redundant functions in the master remote antenna unit **402** and the slave remote antenna unit **404-1** may be removed. For example, the two units may share the same controller and power supply. The slave remote reference clock **622** may not be required as the signal from the master remote reference clock unit **508** could be routed directly to the local oscillator generator **624**.

FIG. 7 is a block diagram of one embodiment of a digital expansion unit **110** of system **100**. Digital expansion unit **110** includes at least one digital input-output unit (DIOU) **702**, at least one digital multiplexing unit (DMU) **704**, at least one digital input-output unit (DIOU) **706**, at least one central processing unit (CPU) **708**, at least one digital expansion clock unit **710**, and at least one power supply **712**.

The digital expansion unit **110** communicates N-bit words of digitized spectrum between the master host unit **104** and

15

at least one hybrid expansion unit 106. Each DIOU 702 (DIOU 702-1 through DIOU 702-N) of the digital expansion unit 110 operates to convert between optical signals received across a digital communication link 114 and electrical signals processed within the digital expansion unit 110. In the downstream, the converted signals are passed from each DIOU 702 to the DMU 704, where they are multiplexed together and output to at least one DIOU 706 which converts the electrical signals to optical signals and outputs the optical signals to at least one hybrid expansion unit or another digital expansion unit for further distribution. In the upstream, each DIOU 706 converts optical signals received from a downstream hybrid expansion unit or digital expansion unit into electrical signals, which are passed onto the DMU 704. The DMU 704 takes the upstream signals and multiplexes them together and outputs them to at least one DIOU 702, which converts the electrical signals into optical signals and sends the optical signals across a digital communication link 114 toward the master host unit. In other embodiments, multiple digital expansion units are daisy chained for expansion in the digital domain.

In the example embodiment shown in FIG. 7, the CPU 708 is used to control each DMU 704. An input/output (I/O) line 714 coupled to CPU 708 is used for network monitoring and maintenance. Typically, I/O line 714 is an Ethernet port used for external communication with the system. The DMU 704 extracts the digital master reference clock signal from any one digital data stream received at any one of the DIOU 702 and DIOU 706 and sends the digital master reference clock signal to the digital expansion clock unit 710. The digital expansion clock unit 710 then provides the digital master reference clock signal to other functions in the DMU that require a clock signal. Power supply 712 is used to power various components within digital expansion unit 110.

What is claimed is:

1. A communication system, comprising:

a master host unit [adapted] configured to communicate [digital] signals with a plurality of service provider interfaces, wherein the master host unit includes a master clock distribution unit that generates a digital master reference clock signal;

[a plurality of communication links coupled to the master host unit, wherein] the master host unit [is] further [adapted] configured to communicate [digitized] digital spectrum in N-bit words over [the] a plurality of communication links coupled to the master host unit; the master host unit further [adapted] configured to interface between the [digital] signals for the plurality of service provider interfaces and N-bit words of [digitized] digital spectrum for the plurality of communication links;

the master host unit further [adapted] configured to communicate [the] a digital master reference clock signal over the plurality of communication links;

at least one hybrid expansion unit, communicatively coupled to the master host unit over at least one of the plurality of communication links and [adapted] configured to communicate N-bit words of [digitized] digital spectrum with the master host unit across the at least one of the plurality of communication links, the at least one hybrid expansion unit further [adapted] configured to convert between the N-bit words of [digitized] digital spectrum and a first set of bands of analog spectrum;

[an analog communication medium coupled to the at least one hybrid expansion unit, wherein] the at least one

16

hybrid expansion unit [is] further [adapted] configured to communicate the first set of bands of analog spectrum across [the] an analog communication medium coupled to the at least one hybrid expansion unit;

each hybrid expansion unit further [adapted] configured to:

receive the digital master reference clock signal across one of the plurality of communication links;

generate an analog reference clock signal based on the [received] digital master reference clock signal; and

send the analog reference clock signal across the analog communication medium; and

at least one remote antenna unit communicatively coupled to one of the at least one hybrid expansion [units] unit over the analog communication medium and [adapted] configured to communicate the first set of bands of analog spectrum with the one of the at least one hybrid expansion [units] unit across the analog communication medium, each remote antenna unit further [adapted] configured to transmit and receive wireless signals over a plurality of air interfaces for [the] associated service provider interfaces;

each of the [plurality of] at least one remote antenna [units] unit further [adapted] configured to receive the analog reference clock signal across the analog communication medium.

2. The system of claim 1, wherein the signals are digital signals; and

wherein the master host unit is [adapted] configured to interface between the digital signals for the plurality of service provider interfaces and N-bit words of [digitized] digital spectrum for the plurality of communication links includes converting between the digital signals for the plurality of service provider interfaces and N-bit words of [digitized] digital spectrum for the plurality of communication links by reformatting digital data between the digital signals and the N-bit words of [digitized] digital spectrum used for communication across the at least one of the plurality of communication links between the master host unit and the at least one hybrid expansion unit.

3. The system of claim 1, wherein the signals are digital signals; and

wherein the master host unit is [adapted] configured to interface between the digital signals for the plurality of service provider interfaces and N-bit words of [digitized] digital spectrum for the plurality of communication links by communicating digital data as is without reformatting between the digital signals and the N-bit words of [digitized] digital spectrum used for communication across the at least one of the plurality of communication links between the master host unit and the at least one hybrid expansion unit.

4. The system of claim 1, wherein the master clock distribution unit generates the digital master reference clock signal based on an external reference clock external to the master host unit.

5. The system of claim 1, wherein each of the [plurality of] at least one remote antenna [units] unit is further [adapted] configured to synchronize at least one component with the system using the analog reference clock signal.

6. The system of claim 1, wherein each of the [plurality of] at least one remote antenna [units] unit is further [adapted] configured to frequency convert the first set of bands of analog spectrum to a second set of bands of analog spectrum.

17

7. The system of claim 1, wherein each hybrid expansion unit generates an analog reference clock signal using a phase-locked loop.

8. The system of claim 1, wherein at least one hybrid expansion unit is further configured to receive the digital master reference clock signal across one of the plurality of communication links by extracting the digital master reference clock signal from a data stream containing the N-bit words of [digitized] digital spectrum.

9. The system of claim 1, wherein the digital master reference clock signal is used to generate clock signals used to convert between the [digital] signals for the plurality of service provider interfaces and N-bit words of [digitized] digital spectrum for the plurality of communication links.

10. The system of claim 1, wherein the N-bit words of [digitized] digital spectrum are communicated in a data stream generated from clock signals derived from the digital master reference clock signal.

11. The system of claim 1, further including a digital expansion unit interposed between the master host unit and at least two hybrid expansion units.

12. The system of claim 1, wherein the at least one remote antenna unit is part of an analog remote antenna cluster.

13. The system of claim 4, wherein the external reference clock external to the master host unit is from at least one of the plurality of service provider interfaces.

14. The system of claim 4, wherein the external reference clock external to the master host unit is from at least one of a base station, a GPS unit, and a cesium atomic clock.

15. The system of claim 6, wherein the signals are digital signals; and

wherein the digital signals for the plurality of service provider interfaces are a digital representation of the second set of bands of analog spectrum.

16. The system of claim 10, wherein the N-bit words of [digitized] digital spectrum are extracted from the data stream at each hybrid expansion unit.

17. The system of claim 11, wherein the digital expansion unit is [adapted] configured to communicate the digital master reference clock signal over the plurality of communication links between the master host unit and the at least two hybrid expansion units.

18. The system of claim 13, wherein the master clock distribution unit derives the external reference clock [signal] external to the master host unit from a data stream communicating the [digital] signals between the plurality of service provider interfaces and the master host unit.

19. A method comprising:

interfacing wireless spectrum for at least two wireless services at a master host unit between [digital] signals and N-bit words of [digitized] digital spectrum;

[generating a digital master reference clock signal at the master host unit;]

transporting the [digitized] digital spectrum as a multiplexed signal on a digital medium between the master host unit and a hybrid expansion unit;

transporting [the] a digital master reference clock signal on the digital medium between the master host unit and the hybrid expansion unit;

converting wireless spectrum for the at least two wireless services between the N-bit words of [digitized] digital spectrum and a first set of bands of analog spectrum at the hybrid expansion unit;

generating an analog reference clock signal based on the digital master reference clock signal received at the hybrid expansion unit;

18

transporting the first set of bands of analog spectrum for the at least two wireless services on an analog medium between the hybrid expansion unit and at least one remote unit having an air interface for each of the at least two wireless services;

transporting the analog reference clock signal on the analog medium between the hybrid expansion unit and the at least one remote unit; and

communicating the wireless spectrum in analog format at the at least one remote unit.

20. The method of claim 19, wherein the signals are digital signals; and

wherein interfacing the wireless spectrum for the at least two wireless services at the master host unit between digital signals and N-bit words of [digitized] digital spectrum includes converting the wireless spectrum for the at least two wireless services at the master host unit between digital signals and N-bit words of [digitized] digital spectrum by reformatting digital data between the digital signals and the N-bit words of [digitized] digital spectrum used for transport on the digital medium between the master host unit and the hybrid expansion unit.

21. The method of claim 19, wherein the signals are digital signals; and

wherein interfacing the wireless spectrum for the at least two wireless services at the master host unit between digital signals and N-bit words of [digitized] digital spectrum includes communicating digital data as is without reformatting between the digital signals and the N-bit words of [digitized] digital spectrum used for transport on the digital medium between the master host unit and the hybrid expansion unit.

22. The method of claim [19] 41, wherein generating the digital master reference clock signal at the master host unit is based on an external reference clock external to the master host unit.

23. The method of claim 19, wherein generating the analog reference clock signal includes extracting the digital master reference clock signal from a data stream containing the N-bit words of [digitized] digital spectrum and converting the digital master reference clock signal to the analog reference clock signal.

24. The method of claim 19, wherein converting the digital master reference clock signal to the analog reference clock signal occurs using a phase-locked loop.

25. The method of claim 19, further comprising:

frequency converting the first set of bands of analog spectrum between a first frequency and a second frequency at the hybrid expansion unit; and wherein the second frequency is different from the first frequency.

26. The method of claim 19, wherein the analog reference clock signal and the first set of bands of analog spectrum are transported as a multiplexed signal.

27. The method of claim 19, wherein transporting the first set of bands of analog spectrum for the at least two wireless services on an analog medium between the hybrid expansion unit and at least one remote unit includes:

transporting the first set of bands of analog spectrum to a master analog remote antenna unit;

transporting at least a first subset of the first set of bands of analog spectrum from the master analog remote antenna unit to a first slave remote antenna unit; and

19

transporting at least a second subset of the first set of bands of analog spectrum from the master analog remote antenna unit to a second slave remote antenna unit.

28. The method of claim 22, *wherein the signals are digital signals; and*

further comprising:

receiving the wireless spectrum for the at least two wireless services as the digital signals at the master host unit from at least one service provider interface.

29. The method of claim 22, wherein [generating] the external reference clock external to the master host unit is from at least one of a base station, a GPS unit, and a cesium atomic clock.

30. The method of claim 27, wherein communicating the wireless spectrum in analog format at the at least one remote unit includes:

communicating at least a first subset of wireless spectrum corresponding to the first subset of the first set of bands of analog spectrum at the first slave remote antenna unit; and

communicating at least a second subset of wireless spectrum corresponding to the second subset of the first set of bands of analog spectrum at the second slave remote antenna unit.

31. The method of claim 28, *wherein the signals are digital signals; and*

wherein generating the digital master reference clock signal at the master host unit includes deriving the external reference clock [signal] *external to the master host unit* from a data stream containing the digital signals received from the at least one service provider interface.

32. A communication system, comprising:

a master host unit, the master host unit [adapted] *configured* to communicate [digital] signals with service provider interfaces;

a hybrid expansion unit coupled to the master host unit by a communication link, the master host unit and the hybrid expansion unit [adapted] *configured* to communicate N-bit words of [digitized] *digital* spectrum over the communication link, the hybrid expansion unit further [adapted] *configured* to convert between the N-bit words of [digitized] *digital* spectrum and a first set of bands of analog spectrum,

a remote antenna unit coupled to the hybrid expansion unit by an analog communication medium, the hybrid expansion unit and the remote antenna unit [adapted] *configured* to communicate the first set of bands of analog spectrum over the analog communication medium, the remote antenna unit further [adapted] *configured* to transmit and receive wireless signals over air interfaces;

[wherein the master host unit includes a master clock distribution unit, the master clock distribution unit adapted to generate a digital master reference clock signal,] the master host unit further [adapted] *configured* to communicate [the] a digital master reference clock signal over the communication link;

wherein the hybrid expansion unit is further [adapted] *configured* to receive the digital master reference clock signal from the master host unit over the communication link, the hybrid expansion unit further [adapted] *configured* to generate an analog reference clock signal based on the digital master reference clock signal, the hybrid expansion unit further [adapted] *configured* to

20

send the analog reference clock signal across the analog communication medium; and

wherein the remote antenna unit is further [adapted] *configured* to receive the analog reference clock signal across the analog communication medium.

33. The system of claim 32, *wherein the signals are digital signals; and*

wherein the master host unit is further [adapted] *configured* to convert between the digital signals for the service provider interfaces and the N-bit words of [digitized] *digital* spectrum by reformatting digital data between the digital signals and the N-bit words of [digitized] *digital* spectrum used for communication across the [at least one of the plurality of] communication [links] *link* between the master host unit and the hybrid expansion unit.

34. The system of claim 32, *wherein the signals are digital signals; and*

wherein the master host unit is further [adapted] *configured* to communicate digital data as is without reformatting between the digital signals and the N-bit words of [digitized] *digital* spectrum used for communication across the [at least one of the plurality of] communication [links] *link* between the master host unit and the hybrid expansion unit.

35. The system of claim [32] 42, wherein the master clock distribution unit is [adapted] *configured* to generate the digital master reference clock signal based on an external reference clock external to the master host unit.

36. The system of claim [32] 35, wherein the external reference clock external to the master host unit is from at least one of a base station, a GPS unit, and a cesium atomic clock.

37. The system of claim 32, wherein the hybrid expansion unit is further configured to receive the digital master reference clock signal from the master host unit over the communication link by extracting the digital master reference clock signal from a data stream containing the N-bit words of [digitized] *digital* spectrum.

38. The system of claim 35, wherein the external reference clock external to the master host unit is from at least one of the service provider interfaces.

39. The system of claim 38, *wherein the signals are digital signals; and*

wherein the master clock distribution unit derives the external reference clock from a data stream communicating the digital signals between service provider interfaces and the master host unit.

40. *The system of claim 1, wherein the master host unit includes a master clock distribution unit, the master clock distribution unit configured to generate the digital master reference clock signal.*

41. *The method of claim 19, further comprising: generating the digital master reference clock signal at the master host unit.*

42. *The system of claim 32, wherein the master host unit includes a master clock distribution unit, the master clock distribution unit configured to generate the digital master reference clock signal.*

43. *The system of claim 1, wherein the signals are analog signals; and*

wherein the master host unit is further configured to interface between the signals for the plurality of service provider interfaces and N-bit words of digital spectrum for the plurality of communication links at least in part by being configured to convert between the analog

*signals and the N-bit words of digital spectrum for the plurality of communication links.*

*44. The method of claim 19, wherein the signals are analog signals; and*

*wherein interfacing wireless spectrum for the at least two 5*  
*wireless services at the master host unit between the signals and N-bit words of digital spectrum includes converting the wireless spectrum for the at least two wireless services at the master host unit between the signals and N-bit words of digital spectrum. 10*

*45. The system of claim 32, wherein the signals are analog signals.*

\* \* \* \* \*