

US00RE48348E

(19) **United States**  
(12) **Reissued Patent**  
Stevenson

(10) **Patent Number:** **US RE48,348 E**  
(45) **Date of Reissued Patent:** **Dec. 8, 2020**

(54) **FEEDTHROUGH FILTER CAPACITOR ASSEMBLY WITH INTERNALLY GROUNDED HERMETIC INSULATOR**

5,333,095	A	7/1994	Stevenson et al.	
5,905,627	A	5/1999	Brendel et al.	
6,529,103	B1	3/2003	Brendel et al.	
6,768,629	B1 *	7/2004	Allen et al.	361/302
2004/0257747	A1	12/2004	Stevenson et al.	A61N 1/3754 361/302
2005/0007718	A1 *	1/2005	Stevenson	A61N 1/3754 361/118
2005/0201039	A1 *	9/2005	Stevenson et al.	361/302

(71) Applicant: **Greatbatch Ltd.**, Clarence, NY (US)  
(72) Inventor: **Robert A. Stevenson**, Canyon Country, CA (US)  
(73) Assignee: **Greatbatch Ltd.**, Clarence, NY (US)

(21) Appl. No.: **15/830,719**  
(22) Filed: **Dec. 4, 2017**

**Related U.S. Patent Documents**

Reissue of:

(64) Patent No.: **7,035,076**  
Issued: **Apr. 25, 2006**  
Appl. No.: **11/161,730**  
Filed: **Aug. 15, 2005**

(51) **Int. Cl.**  
**H01G 4/35** (2006.01)  
**A61N 1/375** (2006.01)

(52) **U.S. Cl.**  
CPC ..... **H01G 4/35** (2013.01); **A61N 1/3754** (2013.01)

(58) **Field of Classification Search**  
CPC ..... **H01G 4/35**; **A61N 1/3754**  
USPC ..... **361/11, 306.2**  
See application file for complete search history.

(56) **References Cited**

**U.S. PATENT DOCUMENTS**

3,920,888	A	11/1975	Barr
4,152,540	A	5/1979	Duncan et al.
4,421,947	A	12/1983	Kyle
4,424,551	A	1/1984	Stevenson et al.

**OTHER PUBLICATIONS**

*AVX vs Greatbatch* IPR2015-00908, Exhibit 2433, U.S. Pat. No. 3,920,888 to Barr, filed at PTAB Dec. 27, 2015.  
*AVX vs Greatbatch* IPR2015-00908, Exhibit 2434, U.S. Pat. No. 4,152,540 to Duncan et al., filed at PTAB Dec. 27, 2015.  
*AVX vs Greatbatch* IPR2015-00908, Exhibit 2435, U.S. Pat. No. 4,421,947 to Kyle, filed at PTAB Dec. 27, 2015.

(Continued)

*Primary Examiner* — Kenneth Whittington  
(74) *Attorney, Agent, or Firm* — Michael F. Scalise

(57) **ABSTRACT**

A feedthrough filter capacitor assembly includes a conductive terminal pin which extends through a first passageway of a capacitor in conductive relation with a first set of electrode plates, and through a conductive ferrule and an insulator in non-conductive relation. The insulator includes ground plates conductively coupled to the ferrule. A second set of electrode plates of the capacitor are conductively coupled to the insulator ground plates, such as by a ground pin extending through the capacitor in relation with the second set of electrode plates, and at least partially extending through a second passageway of the insulator in conductive relation with the ground plates. In this manner, the exterior electrical/mechanical connection between the capacitor and ferrule or other ground member is eliminated.

**46 Claims, 9 Drawing Sheets**

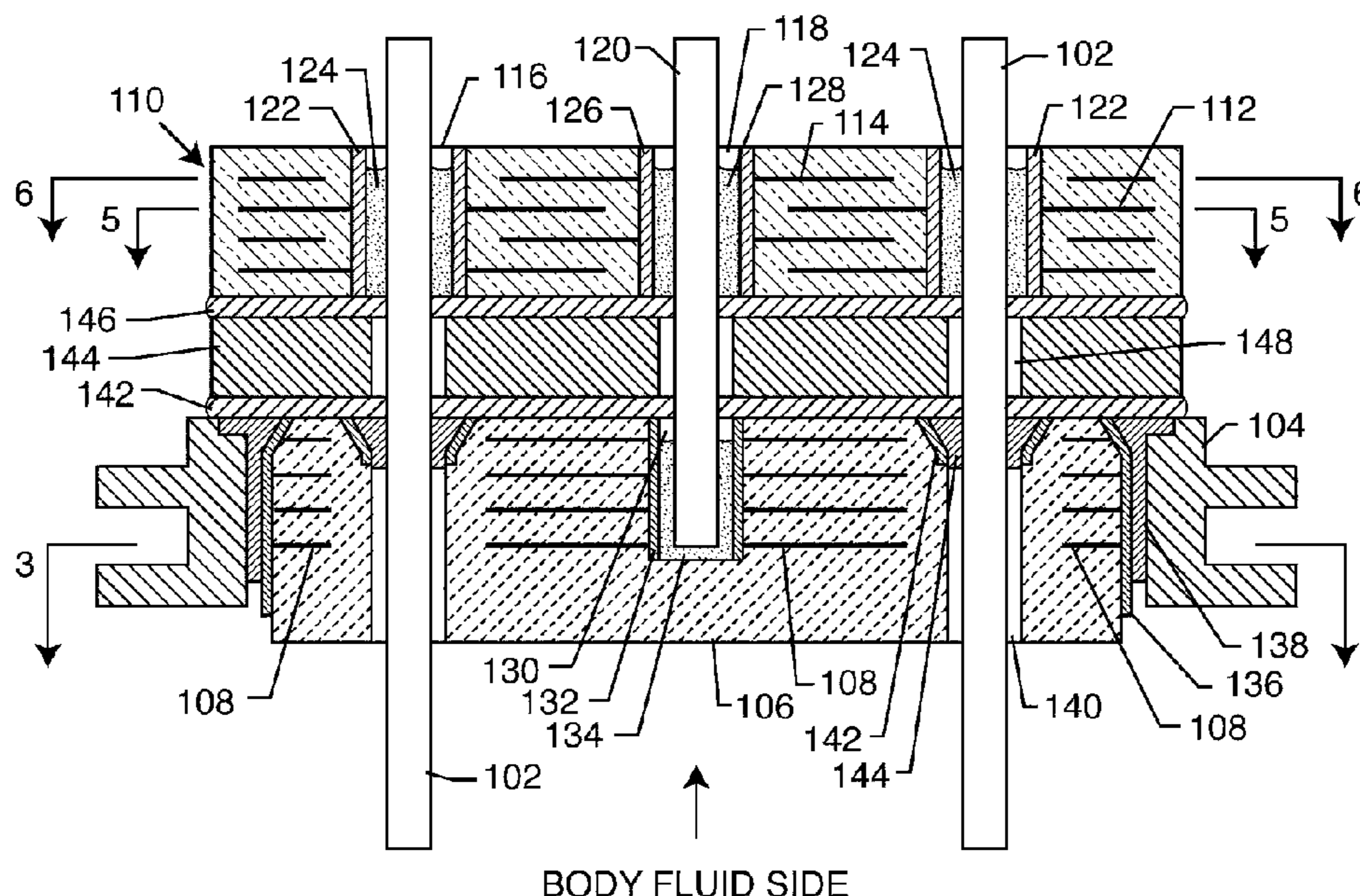

(56)

## References Cited

## OTHER PUBLICATIONS

- AVX vs Greatbatch* IPR2015-00908, Exhibit 2436, U.S. Pat. No. 4,424,551 to Stevenson et al., filed at PTAB Dec. 27, 2015.
- AVX vs Greatbatch* IPR2015-00908, Exhibit 2437, U.S. Pat. No. 5,333,095 to Stevenson et al., filed at PTAB Dec. 27, 2015.
- AVX vs Greatbatch* IPR2015-00908, Exhibit 2438, U.S. Pat. No. 5,905,627 to Brendel et al., filed at PTAB Dec. 27, 2015.
- AVX vs Greatbatch* IPR2015-00908, Exhibit 2439, U.S. Pat. No. 6,529,103 to Brendel et al., filed at PTAB Dec. 27, 2015.
- AVX vs Greatbatch* IPR2015-00908, Exhibit 2440, U.S. Pat. No. 6,768,629 to Allen et al., filed at PTAB Dec. 27, 2015.
- AVX vs Greatbatch* IPR2015-00908, Exhibit 2441, U.S. Pat. No. 2004/0257747 to Stevenson et al., filed at PTAB Dec. 27, 2015.
- AVX vs Greatbatch* IPR2015-00908, Exhibit 2442, U.S. Pat. No. 3005/0201039 to Stevenson et al., filed at PTAB Dec. 27, 2015.
- AVX vs Greatbatch* IPR2015-00908, Exhibit 2443, U.S. Pat. No. 4,925,607 to Kyle., filed at PTAB Dec. 27, 2015.
- AVX vs Greatbatch* IPR2015-00908, Exhibit 2444, U.S. Pat. No. 6,566,978 to Stevenson et al., filed at PTAB Dec. 27, 2015.
- AVX vs Greatbatch* IPR2015-00908, Exhibit 2445, U.S. Pat. No. 7,623,335 to Stevenson et al., filed at PTAB Dec. 27, 2015.
- AVX vs Greatbatch* IPR2015-00908, Exhibit 2446, U.S. Pat. No. 6,987,660 to Stevenson et al., filed at PTAB Dec. 27, 2015.
- AVX vs Greatbatch* IPR2015-00908, Exhibit 2447, U.S. Pat. No. 7,765,005 to Stevenson, filed at PTAB Dec. 27, 2015.
- AVX vs Greatbatch* IPR2015-00908, Exhibit 2448, U.S. Pat. No. 7,310,216 to Stevenson et al., filed at PTAB Dec. 27, 2015.
- AVX vs Greatbatch* IPR2015-00908, Exhibit 2449, PCT WO2004105572 to Stevenson et al., filed at PTAB Dec. 27, 2015.
- AVX vs Greatbatch* IPR2015-00908, Exhibit 2450, U.S. Pat. No. 6,888,715 to Stevenson et al., filed at PTAB Dec. 27, 2015.
- AVX vs Greatbatch* IPR2015-00908, Exhibit 2451, U.S. Pat. No. 6,765,780 to Brendel et al., filed at PTAB Dec. 27, 2015.
- AVX vs Greatbatch* IPR2015-00908, Exhibit 2452, U.S. Pat. No. 6,765, 779 to Stevenson et al., filed at PTAB Dec. 27, 2015.
- AVX vs Greatbatch* IPR2015-00908, Exhibit 2453, U.S. Pat. No. 6,985,347 to Stevenson et al., filed at PTAB Dec. 27, 2015.
- AVX vs Greatbatch* IPR2015-00908, Exhibit 2454, Declaration of Christine Frysz, filed at PTAB Dec. 27, 2015.
- AVX vs Greatbatch* IPR2015-00908, Exhibit 2455, Declaration of Haytham Hussein, unsigned, filed at PTAB Dec. 27, 2015.
- AVX vs Greatbatch* IPR2015-00908, Exhibit 2455-2, Declaration of Haytham Hussein, signed, filed at PTAB Jan. 5, 2016.
- AVX vs Greatbatch* IPR2015-00908, Exhibit 2456, Declaration of Richard Brendel, filed at PTAB Dec. 27, 2015.
- AVX vs Greatbatch* IPR2015-00908, Exhibit 2457, Declaration of Ryan Stevenson, filed at PTAB Dec. 27, 2015.
- AVX vs Greatbatch* IPR2015-00908, Exhibit 2458, Declaration of Scott Knappen, unsigned, filed at PTAB Dec. 27, 2015.
- AVX vs Greatbatch* IPR2015-00908, Exhibit 2458-2, Declaration of Scott Knappen, signed, filed at PTAB Jan. 4, 2016.
- AVX vs Greatbatch* IPR2015-00908, Exhibit 2459, Declaration of Bob Stevenson—Ownership, filed at PTAB Dec. 27, 2015.
- AVX vs Greatbatch* IPR2015-00908, Exhibit 2460, Abstract of Recorded from inventors to Greatbatch-Sierra, Inc. for 7038900, filed at PTAB Dec. 27, 2015.
- AVX vs Greatbatch* IPR2015-00908, Exhibit 2461, Abstract of Title, from inventors to Greatbatch-Sierra, Inc. for 7035076, filed at PTAB Dec. 27, 2015.
- AVX vs Greatbatch* IPR2015-00908, Exhibit 2462, PAIR IFW tab for U.S. Appl. No. 11/161,730 issued as USP 7035076, filed at PTAB Dec. 27, 2015.
- AVX vs Greatbatch* IPR2015-00908, Exhibit 2463, Declaration of Bob Stevenson, filed at PTAB Dec. 27, 2015.
- AVX vs Greatbatch* IPR2015-00908, Exhibit 2464, Declaration of Robert Mihail, filed at PTAB Dec. 27, 2015.
- AVX vs Greatbatch* IPR2015-00908, Exhibit 2465, Definition of third, filed at PTAB Apr. 23, 2016.
- AVX vs Greatbatch* IPR2015-00908, Exhibit 2466, Definition of set, filed at PTAB Apr. 23, 2016.
- AVX vs Greatbatch* IPR2015-00908, Exhibit 2467, Definition of refers, filed at PTAB Apr. 23, 2016.
- AVX vs Greatbatch* IPR2015-00908, Exhibit 2468, Definition of embedded, filed at PTAB Apr. 23, 2016.
- AVX vs Greatbatch* IPR2015-00908, Exhibit 2469, Declaration of Robert A. Stevenson, filed at PTAB Apr. 23, 2016.
- AVX vs Greatbatch* IPR2015-00908, Paper 32, Final Written Decision-35 U.S.C. 316(d) and 318 and 37 C.F.R. 42.73, from the Board Sep. 20, 2016.
- AVX vs Greatbatch* IPR2015-00908, Exhibit 2082, Hazzard et al., Ex. 1011 marked by Mr. Galvagni, filed at PTAB Jun. 25, 2015.
- AVX vs Greatbatch* IPR2015-00908, Exhibit 2093, Galvagni et al., So Many Electrons, So Little Time, filed at PTAB Jun. 25, 2015.
- AVX vs Greatbatch* IPR2015-00908, Exhibit 2094, AVX Technical Information, filed at PTAB Jun. 25, 2015.
- AVX vs Greatbatch* IPR2015-00908, Exhibit 2096, Galvagni drawing of Hazzard device, filed at PTAB Jun. 25, 2015.
- AVX vs Greatbatch* IPR2015-00908, Exhibit 2042, Definition of Conductive Coupling, filed at PTAB Jun. 25, 2015.
- AVX vs Greatbatch* IPR2015-00908, Exhibit 2100, Definition of Direct Coupling, filed at PTAB Jun. 25, 2015.
- AVX vs Greatbatch* IPR2015-00908, Exhibit 2101, Galvagni Deposition Transcript from Dec. 10, 2014, filed at PTAB Jun. 25, 2015.
- AVX vs Greatbatch* IPR2015-00908, Exhibit 2106, Paper disclosing Stevenson 539 Invention, filed at PTAB Jun. 25, 2015.
- AVX vs Greatbatch* IPR2015-00908, Exhibit 2106, CARTS 1998, filed at PTAB Jun. 25, 2015.
- AVX vs Greatbatch* IPR2015-00908, Exhibit 2114, Definition of Conductive Coupling from McGraw-Hill Dictionary of Scientific and Technical Terms, filed at PTAB Jun. 25, 2015.
- AVX vs Greatbatch* IPR2015-00908, Exhibit 2130, Definition of Inductance, from Wikipedia, filed at PTAB Jun. 25, 2015.
- AVX vs Greatbatch* IPR2015-00908, Exhibit 2134, Robert A. Stevenson Curriculum Vitae, filed at PTAB Apr. 23, 2016.
- AVX vs Greatbatch* IPR2015-00908, Exhibit 2135, Biot-Savart Law, from Wikipedia, filed at PTAB Jun. 25, 2015.
- AVX vs Greatbatch* IPR2015-00908, Exhibit 2136, U.S. Pat. No. 6,459,561, filed at PTAB Jun. 25, 2015.
- AVX vs Greatbatch* IPR2015-00908, Exhibit 2137, U.S. Pat. No. 6,496,355, filed at PTAB Jun. 25, 2015.
- AVX vs Greatbatch* IPR2015-00908, Exhibit 2138, U.S. Pat. No. 7,724,496, filed at PTAB Jun. 25, 2015.
- AVX vs Greatbatch* IPR2015-00908, Exhibit 2140, Online wire inductance calculator, filed at PTAB Jun. 25, 2015.
- AVX vs Greatbatch* IPR2015-00908, Exhibit 2141, Blown up view of wire inductance formula of Exhibit 2140, filed at PTAB Jun. 25, 2015.
- AVX vs Greatbatch* IPR2015-00908, Exhibit 2144, First Declaration of Robert A. Stevenson, filed at PTAB Jun. 25, 2015.
- AVX vs Greatbatch* IPR2015-00908, Exhibit 2145, Second Declaration of Robert A. Stevenson, filed at PTAB Mar. 25, 2015.
- AVX vs Greatbatch* IPR2015-00908, Exhibit 2153, Executed Errata for Galvagni deposition, filed at PTAB Jun. 25, 2015.
- AVX vs Greatbatch* IPR2015-00908, Exhibit 2155, Stevenson, Improved EMI Filter Insertion Loss Test Methods Equipment and Fixtures, filed at PTAB Jun. 25, 2015.
- AVX vs Greatbatch* IPR2015-00908, Exhibit 2156, Definition of Insertion Loss, Wikipedia, filed at PTAB Jun. 25, 2015.
- AVX vs Greatbatch* IPR2015-00908, Exhibit 2158, Design and Application of Broadband EMI Filter, Stevenson, filed at PTAB Jun. 25, 2015.
- AVX vs Greatbatch* IPR2015-00908, Exhibit 2161, Hayt, Engineering Electromagnetics, filed at PTAB Jun. 25, 2015.
- AVX vs Greatbatch* IPR2015-00908, Exhibit 2166, Galvagni Ex 2096, Insertion Loss Simulation by Prof. Stevenson, filed at PTAB Jun. 25, 2015.
- AVX vs Greatbatch* IPR2015-00908, Exhibit 2171, Galvagni Ex 2096, based insertion loss calculations, filed at PTAB May 25, 2015.
- AVX vs Greatbatch* IPR2015-00908, Exhibit 2174, Hazzard, AIMD based insertion loss calculations, filed at PTAB May 25, 2015.

(56)

## References Cited

## OTHER PUBLICATIONS

*AVX vs Greatbatch* IPR2015-00908, Exhibit 2175, Fifth Declaration of Robert A. Stevenson, filed at PTAB Jun. 25, 2015.

*AVX vs Greatbatch* IPR2015-00908, Exhibit 2418, Order, construing Conductively Coupled, filed at PTAB Jun. 25, 2015.

*AVX vs Greatbatch* IPR2015-00908, Exhibit 2419, Definition of plate, Collins English Dictionary, filed at PTAB May 25, 2015.

*AVX vs Greatbatch* IPR2015-00908, Exhibit 2420, Definition of plate, American Heritage Dictionary, filed at PTAB May 25, 2015.

*AVX vs Greatbatch* IPR2015-00908, Exhibit 2421, IPR2014-00697 Ex 1018 Second Declaration of John Galvagni, filed at PTAB Jun. 25, 2015.

*AVX vs Greatbatch* IPR2015-00908, Exhibit 2422, IPR2014-00697 Ex 1002 Galvagni 1st Declaration, filed at PTAB Mar. 25, 2015.

*AVX vs Greatbatch* IPR2015-00908, Exhibit 2423, IPR2014-00697 Ex 1013 Galvagni CV, filed at PTAB Jun. 25, 2015.

*AVX vs Greatbatch* IPR2015-00908, Exhibit 2424, IPR2014-00697 Ex 1011 Hazzard, filed at PTAB Jun. 25, 2015.

*AVX vs Greatbatch* IPR2015-00908, Exhibit 2425, Definition of passageway, Macmillan Dictionary, filed at PTAB Mar. 25, 2015.

*AVX vs Greatbatch* IPR2015-00908, Exhibit 2426, Definition of which, from Dictionary, filed at PTAB Jun. 25, 2015.

*AVX vs Greatbatch* IPR2015-00908, Exhibit 2427, Definition of ground plane from Wikipedia, filed at PTAB Jun. 25, 2015.

*AVX vs Greatbatch* IPR2015-00908, Exhibit 2428, U.S. Pat. No. 6,100,200, filed at PTAB Jun. 25, 2015.

*AVX vs Greatbatch* IPR2015-00908, Exhibit 2429, ICD Dimensions from clevelandclinicmeded.com, filed at PTAB Mar. 25, 2015.

*AVX vs Greatbatch* IPR2015-00908, Exhibit 2430, Wire inductance 4.26 nH, filed at PTAB Jun. 25, 2015.

*AVX vs Greatbatch* IPR2015-00908, Exhibit 2431, Definition of Trace, Electronics Industry Glossary, filed at PTAB Jun. 25, 2015.

*AVX vs Greatbatch* IPR2015-00908, Exhibit 2432, Definition of Extend, from vocabulary.com, filed at PTAB Jun. 25, 2015.

*AVX vs Greatbatch* IPR2015-00908, Exhibit 2470, on Petition for Rehearing, Filed at PTAB Aug. 12, 2016.

*AVX vs Greatbatch* IPR2015-00908, Patent Owner List of Exhibits, Filed at PTAB Aug. 12, 2016.

*AVX vs Greatbatch* IPR2015-00908, Patent Owner Related Matter Update to Mandatory Notices, Filed at PTAB Aug. 12, 2016.

*AVX vs Greatbatch* IPR2015-00908, Patent Owner Mandatory Notices, Filed at PTAB Sep. 28, 2016.

*AVX vs Greatbatch* IPR2015-00908, Petition for Inner Parties Review of U.S. Pat. No. 7,035,076, Filed at PTAB Mar. 20, 2015.

*AVX vs Greatbatch* IPR2015-00908, Petitioners Power of Attorney for an Inter Parties Review, Filed at PTAB Mar. 25, 2016.

*AVX vs Greatbatch* IPR2015-00908, Notice of Filing Date Accorded to Petition, Mar. 26, 2015.

*AVX vs Greatbatch* IPR2015-00908, Power of Attorney, Filed at PTAB Apr. 13, 2015.

*AVX vs Greatbatch* IPR2015-00908, Patent Owner Mandatory Notices, Filed at PTAB Apr. 13, 2015.

*AVX vs Greatbatch* IPR2015-00908, Patent Owner Preliminary Response, Filed at PTAB Jun. 25, 2015.

*AVX vs Greatbatch* IPR2015-00908, Patent Owner List of Exhibits, Filed at PTAB Jun. 25, 2015.

*AVX vs Greatbatch* IPR2015-00908, Decision Institution of Inter Parties Review, Sep. 24, 2015.

*AVX vs Greatbatch* IPR2015-00908, Scheduling Order, Sep. 24, 2015.

*AVX vs Greatbatch* IPR2015-00908, Patent Owner Updated Mandatory Notices, Filed at PTAB Oct. 1, 2015.

*AVX vs Greatbatch* IPR2015-00908, Patent Owner's Objections to Evidence Served with Petition, Filed at PTAB Oct. 7, 2015.

*AVX vs Greatbatch* IPR2015-00908, Patent Owner Updated Mandatory Notices, Filed at PTAB Nov. 11, 2015.

*AVX vs Greatbatch* IPR2015-00908, Patent Owner Response, Filed at PTAB Dec. 27, 2015.

*AVX vs Greatbatch* IPR2015-00908, Patent Owner Motion to Amend, Filed at PTAB Dec. 27, 2015.

*AVX vs Greatbatch* IPR2015-00908, Patent Owner List of Exhibits, Filed at PTAB Dec. 27, 2015.

*AVX vs Greatbatch* IPR2015-00908, Patent Owner List of Exhibits, Filed at PTAB Jan. 4, 2016.

*AVX vs Greatbatch* IPR2015-00908, Patent Owner List of Exhibits, Filed at PTAB Jan. 5, 2016.

*AVX vs Greatbatch* IPR2015-00908, Patent Owner Updated Mandatory Notices, Filed at PTAB Feb. 12, 2016.

*AVX vs Greatbatch* IPR2015-00908, Petitioner's Opposition to Patent Owner's Motion to Amend, Filed at PTAB Mar. 25, 2016.

*AVX vs Greatbatch* IPR2015-00908, Patent Owner Reply to Opposition to Motion to Amend, Filed at PTAB Apr. 23, 2016.

*AVX vs Greatbatch* IPR2015-00908, Patent Owner List of Exhibits, Filed at PTAB Apr. 23, 2016.

*AVX vs Greatbatch* IPR2015-00908, Petitioner's Identification of Improper Evidence and Arguments in Patent Owner's Reply to Opposition to Motion to Amend, Filed at PTAB May 5, 2016.

*AVX vs Greatbatch* IPR2015-00908, Patent Owner Response to Petitioner's Beyond Scope Assertions, Filed at PTAB May 6, 2016.

*AVX vs Greatbatch* IPR2015-00908, Patent Owner Request for Oral Argument, Filed at PTAB May 13, 2016.

*AVX vs Greatbatch* IPR2015-00908, Patent Owner Designation of Backup Counsel, Filed at PTAB May 13, 2016.

*AVX vs Greatbatch* IPR2015-00908, Patent Owner Power of Attorney, Filed at PTAB May 16, 2016.

*AVX vs Greatbatch* IPR2015-00908, Patent Owner and Petitioner Joint Waiver of Oral Hearing, Filed at PTAB Jun. 16, 2016.

*AVX vs Greatbatch* IPR2015-00908, Order Conduct of the Proceeding, Entered Jun. 14, 2016.

*AVX vs Greatbatch* IPR2015-00908, Petitioner's Exhibit 1001, U.S. Pat. No. 7,035,076, Filed at PTAB Mar. 20, 2015.

*AVX vs Greatbatch* IPR2015-00908, Petitioner's Exhibit 1002, U.S. Pat. No. 7,038,900, Filed at PTAB Mar. 20, 2015.

*AVX vs Greatbatch* IPR2015-00908, Petitioner's Exhibit 1003, U.S. Pat. No. 6,529,103, Filed at PTAB Mar. 20, 2015.

*AVX vs Greatbatch* IPR2015-00908, Petitioner's Exhibit 1004, U.S. Pat. No. 6,414,835, Filed at PTAB Mar. 20, 2015.

*AVX vs Greatbatch* IPR2015-00908, Petitioner's Exhibit 1005, Notice of Allowance for U.S. Appl. No. 11/161,730, Filed at PTAB Mar. 20, 2015.

*AVX vs Greatbatch* IPR2015-00908, Petitioner's Exhibit 1006, U.S. Appl. No. 60/508,426, Filed at PTAB Mar. 20, 2015.

*AVX vs Greatbatch* IPR2015-00908, Petitioner's Exhibit 1007, Declaration of John Galvagni, Filed at PTAB Mar. 20, 2015.

*AVX vs Greatbatch* IPR2015-00908, Petitioner's Exhibit 1008, Curriculum Vitae of John Galvagni, Filed at PTAB Mar. 20, 2015.

*AVX vs Greatbatch* IPR2015-00908, Patent Owner's Exhibit 2016, Definition of Capacitance from Wikipedia, Filed at PTAB Jun. 25, 2015.

*AVX vs Greatbatch* IPR2015-00908, Patent Owner's Exhibit 2017, Definition of Capacitance from The Free Dictionary, Filed at PTAB Jun. 25, 2015.

*AVX vs Greatbatch* IPR2015-00908, Patent Owner's Exhibit 2039, AVX EMI Filters Catalogue, Filed at PTAB Mar. 25, 2015.

*AVX vs Greatbatch* IPR2015-00908, Patent Owner's Exhibit 2042, Definition Conductive Coupling from Answers.com, Filed at PTAB Jun. 25, 2015.

*AVX vs Greatbatch* IPR2015-00908, Patent Owner's Exhibit 2049, Definition of Passageway from Oxford Dictionaries, Filed at PTAB Jun. 25, 2015.

*AVX vs Greatbatch* IPR2015-00908, Patent Owner's Exhibit 2055, Definition of Electrical Impedance from Wikipedia, Filed at PTAB Jun. 25, 2015.

*AVX vs Greatbatch* IPR2015-00908, Patent Owner's Exhibit 2060, Definition of Conductive Coupling and Direct Coupling from Wikipedia, Filed at PTAB Jun. 25, 2015.

*AVX vs Greatbatch* IPR2015-00908, Patent Owner's Exhibit 2067, Definition of Through, from Oxford, Filed at PTAB May 25, 2015.

*AVX vs Greatbatch* IPR2015-00908, Patent Owner's Exhibit 2076, Patent Owner's Objections to Evidence from IPR2014-00697, Filed at PTAB Jun. 25, 2015.

\* cited by examiner

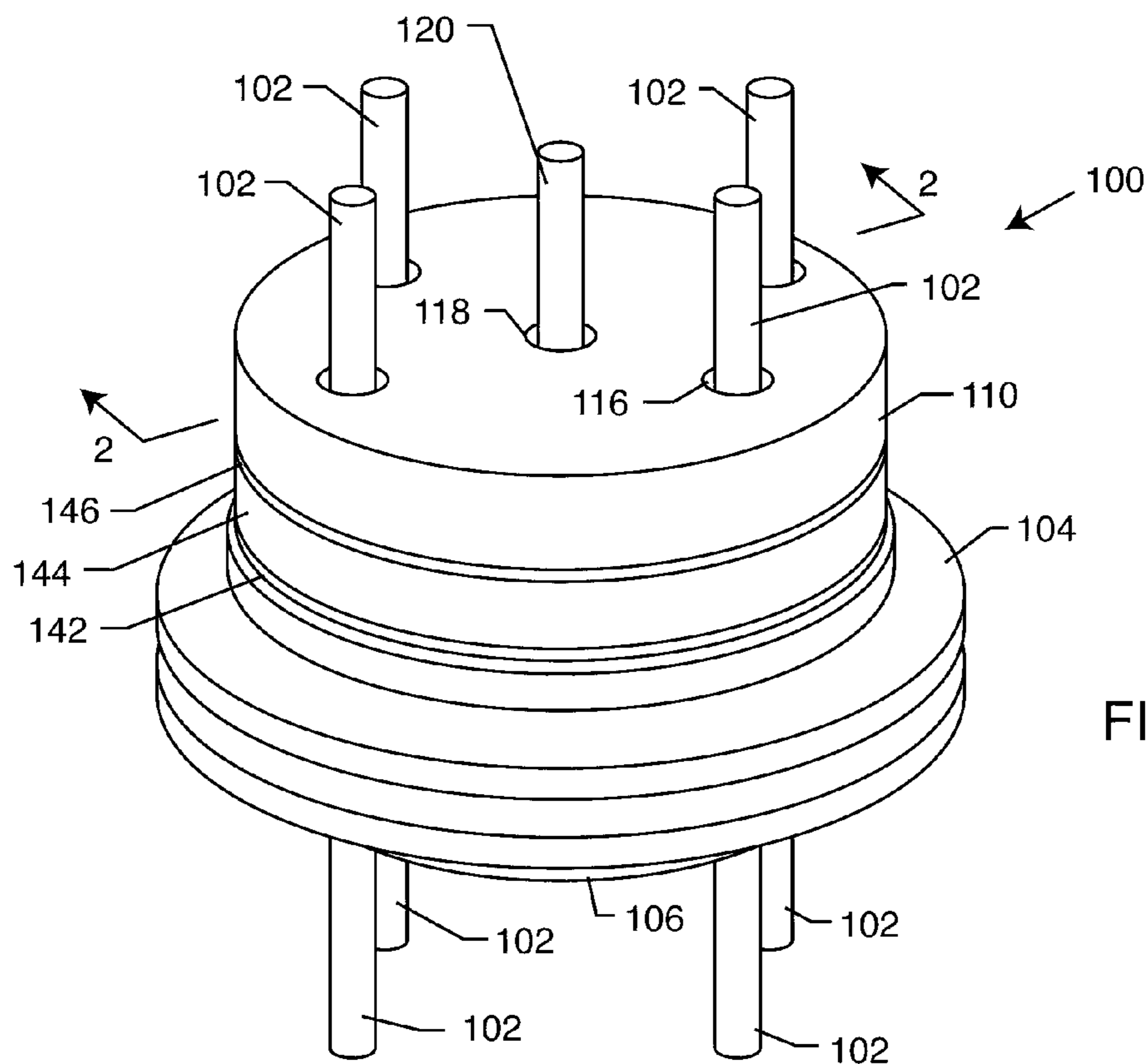

FIG. 1

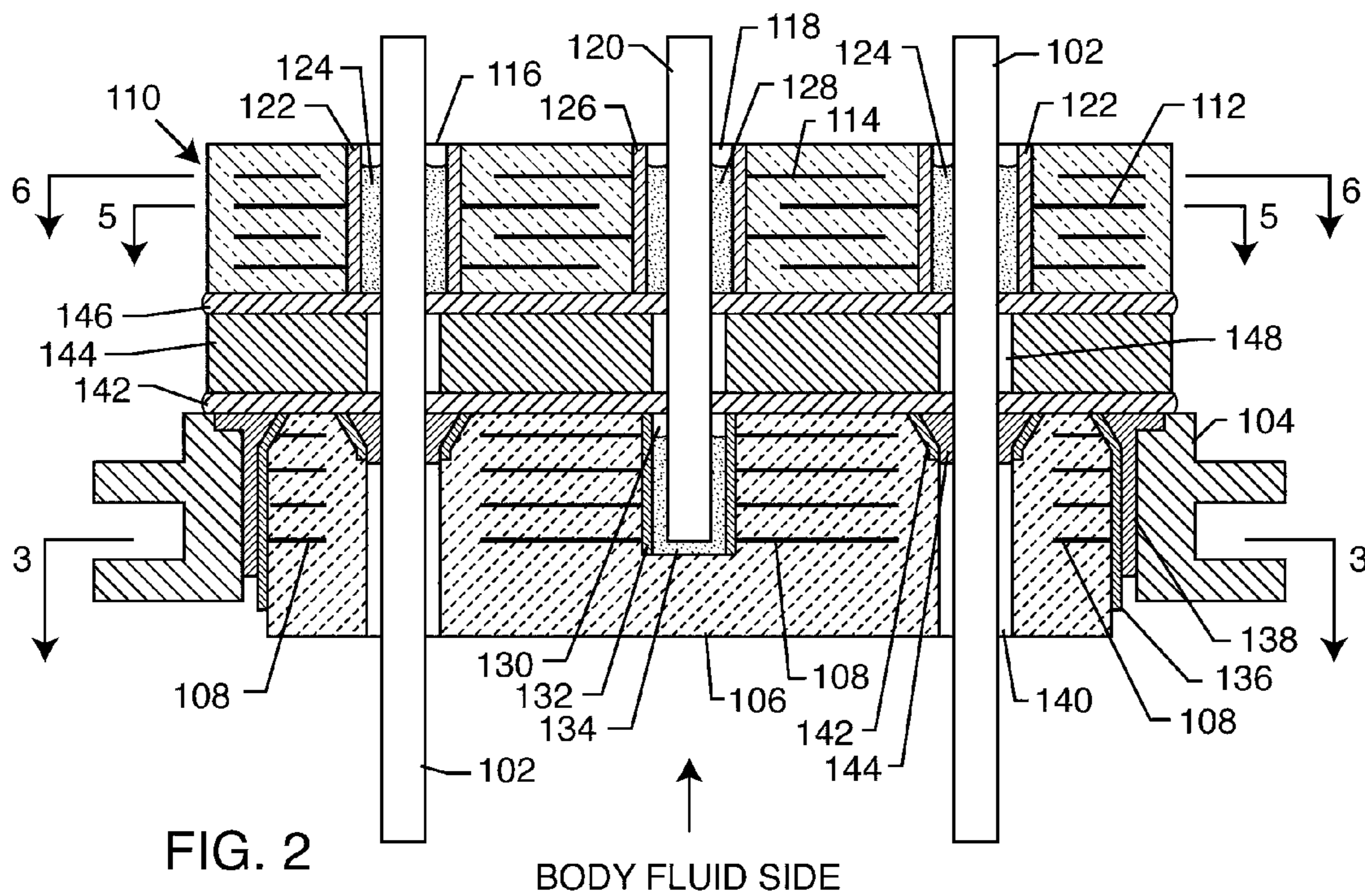

FIG. 2

BODY FLUID SIDE

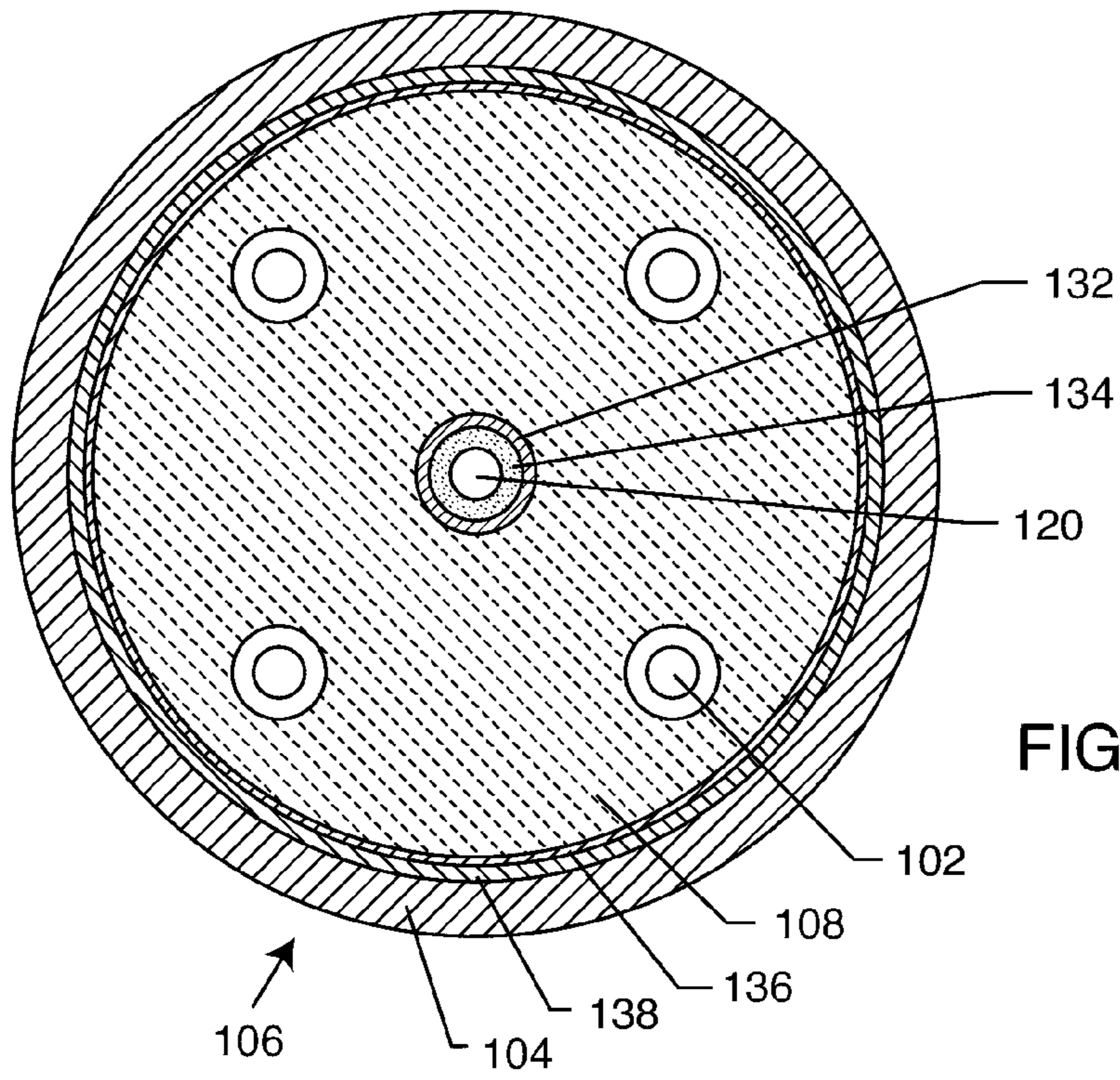

FIG. 3

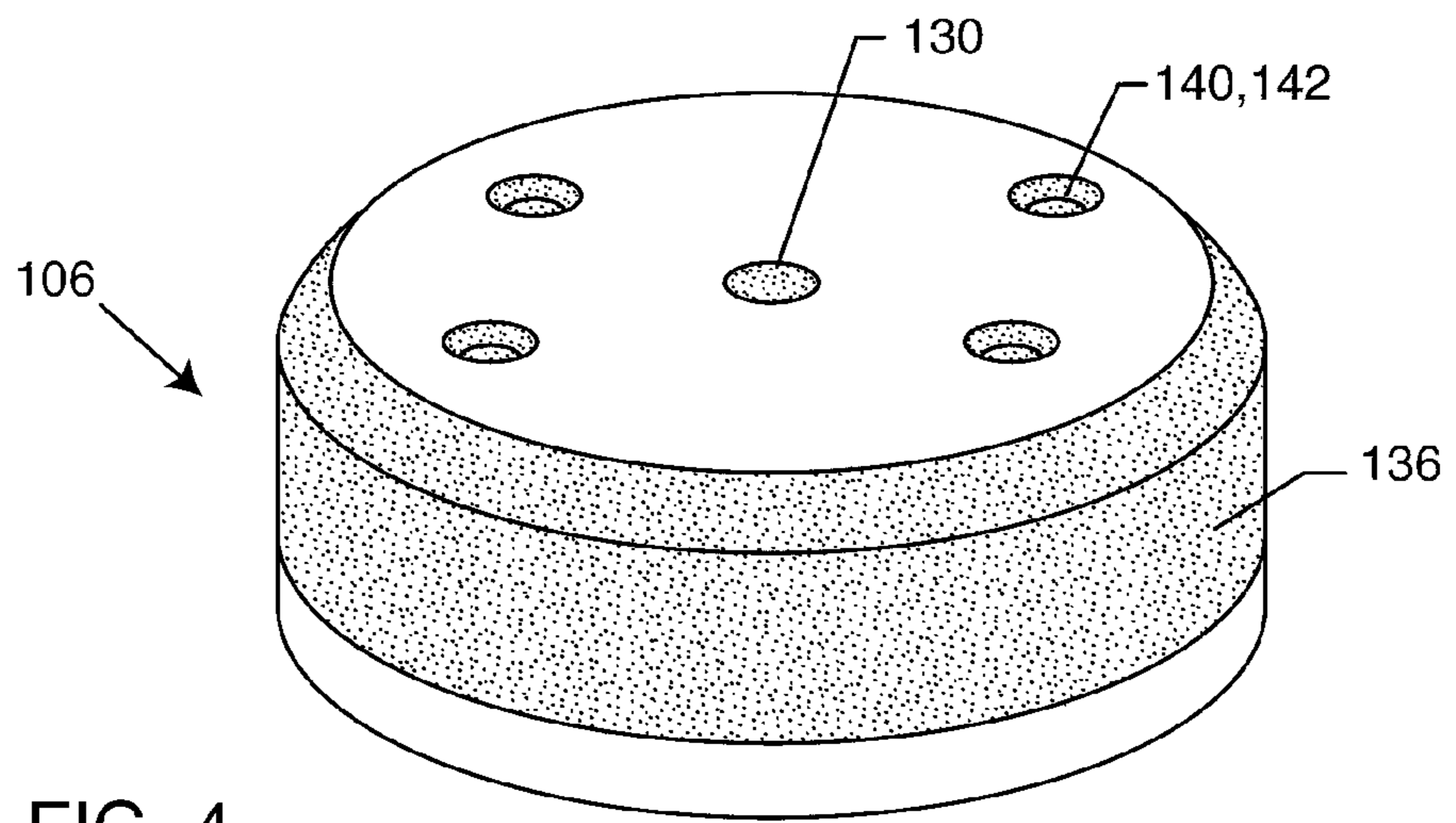

FIG. 4

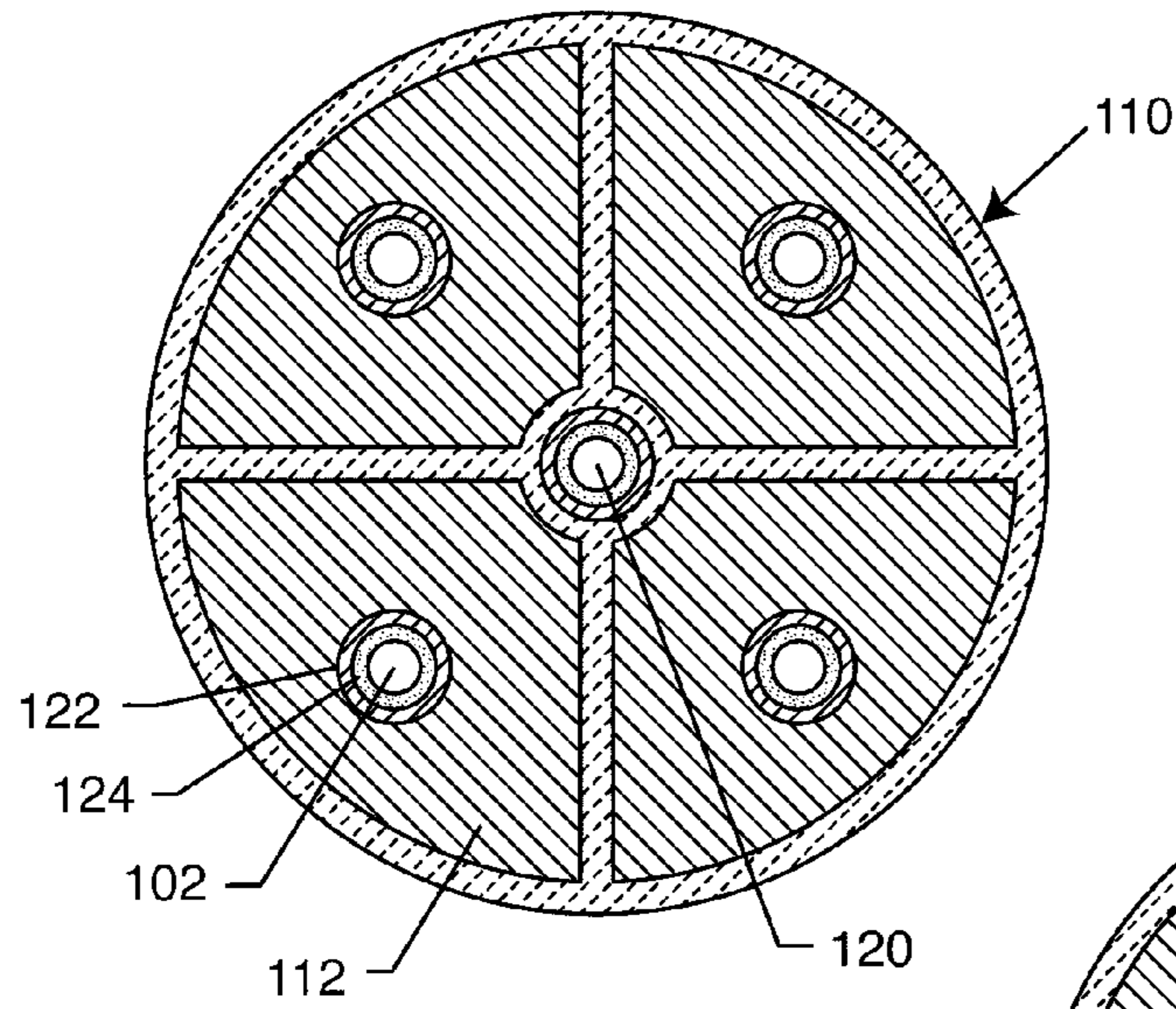

FIG. 5

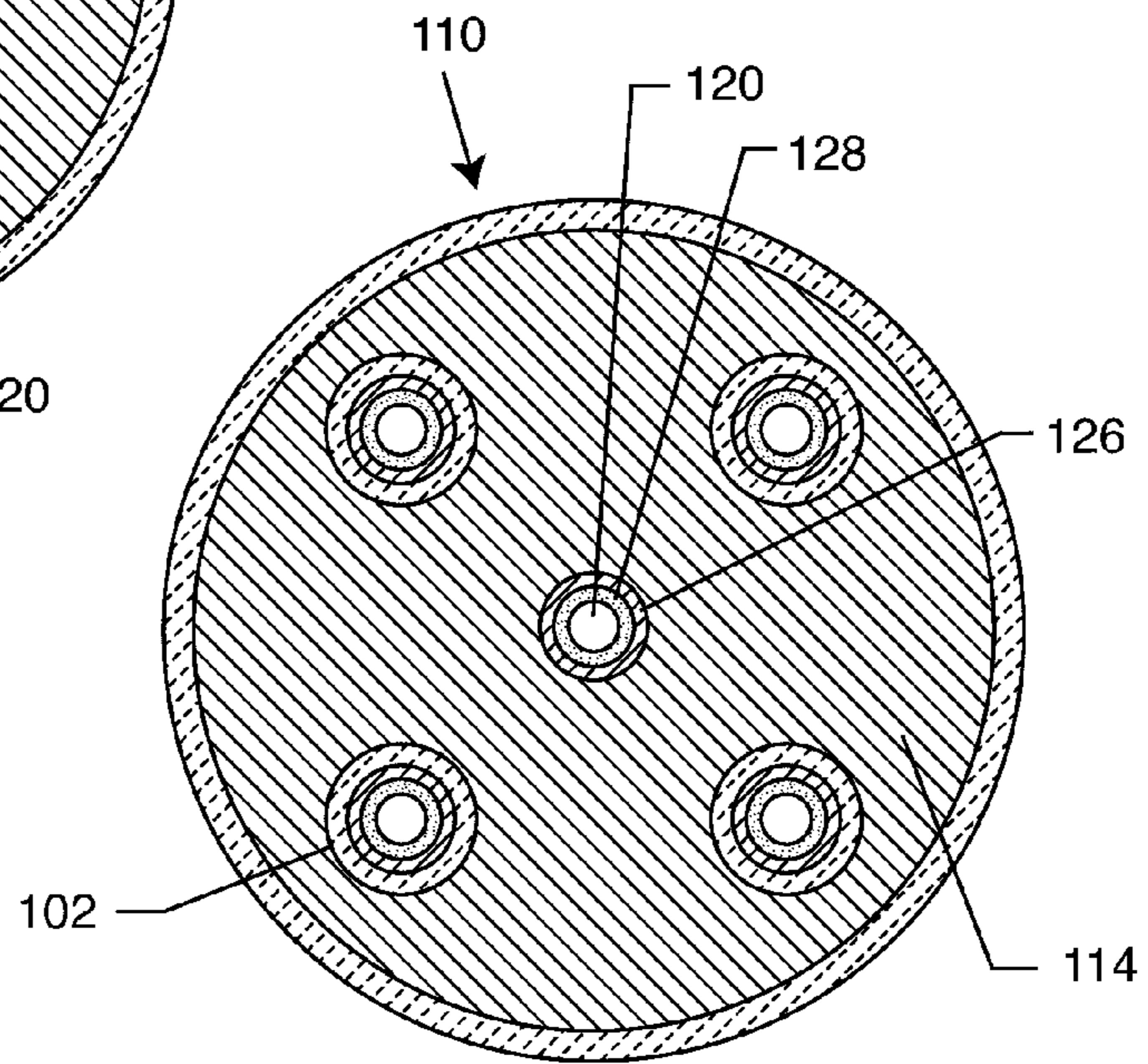

FIG. 6

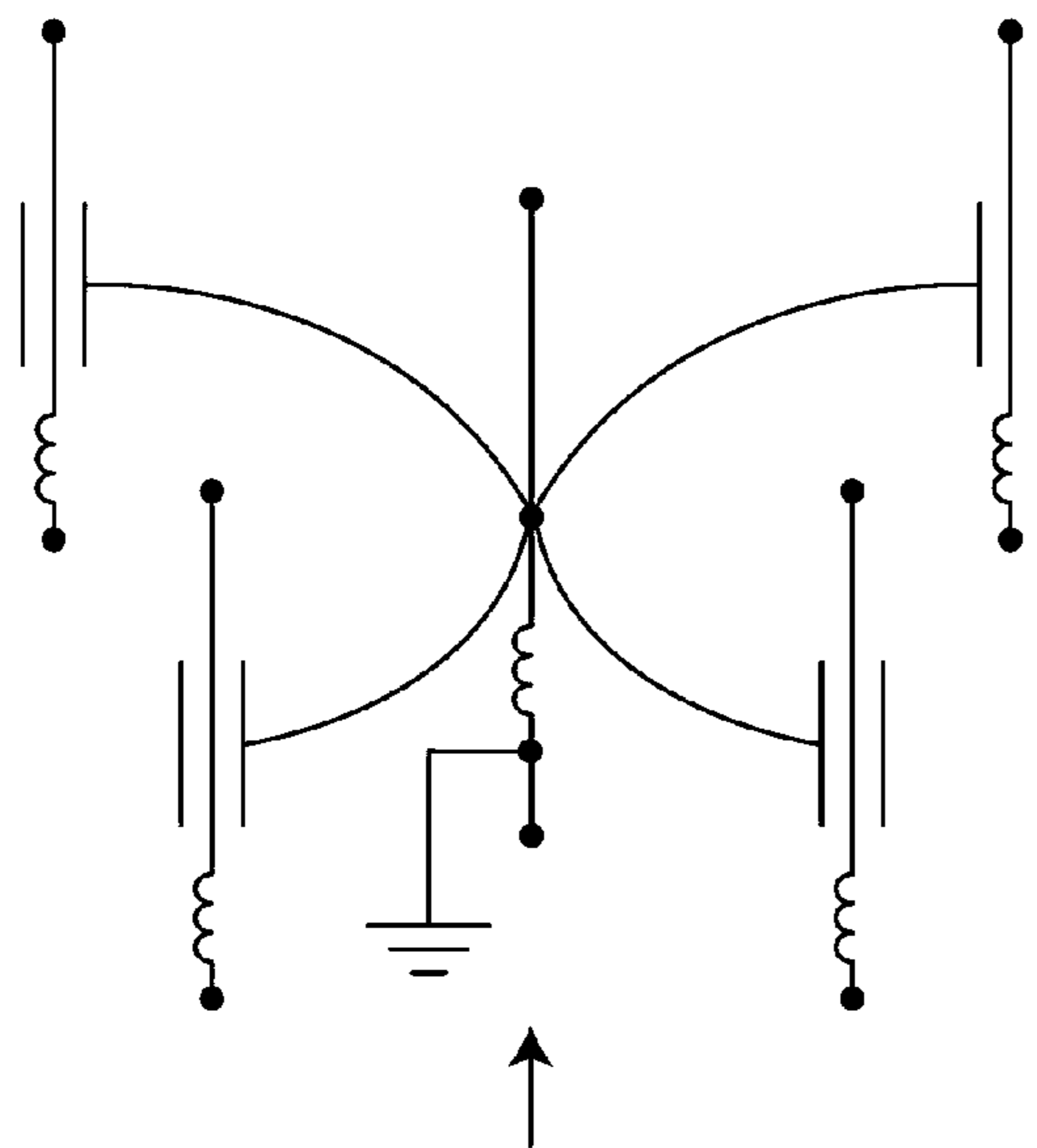

FIG. 7

BODY FLUID SIDE

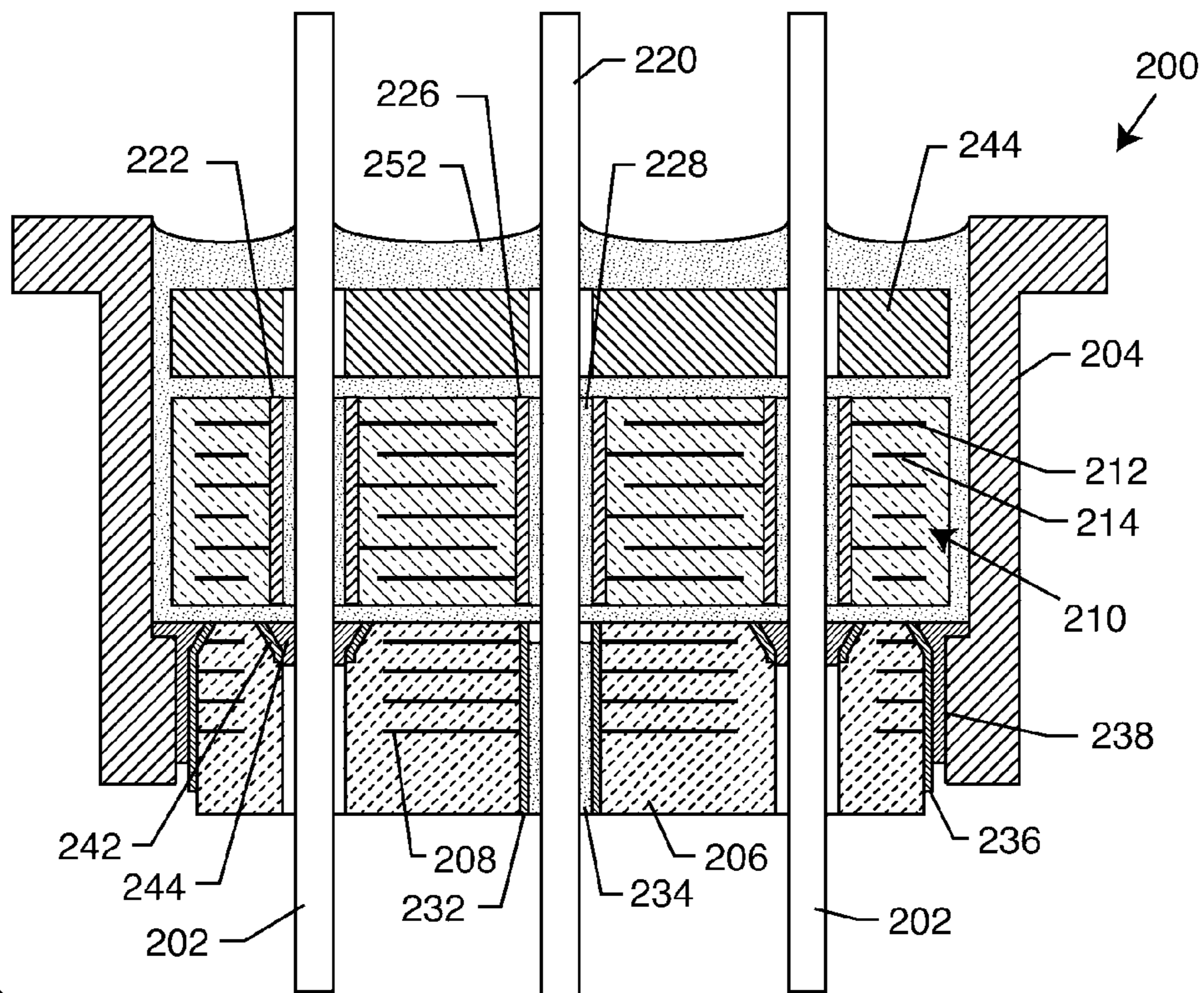

FIG. 8

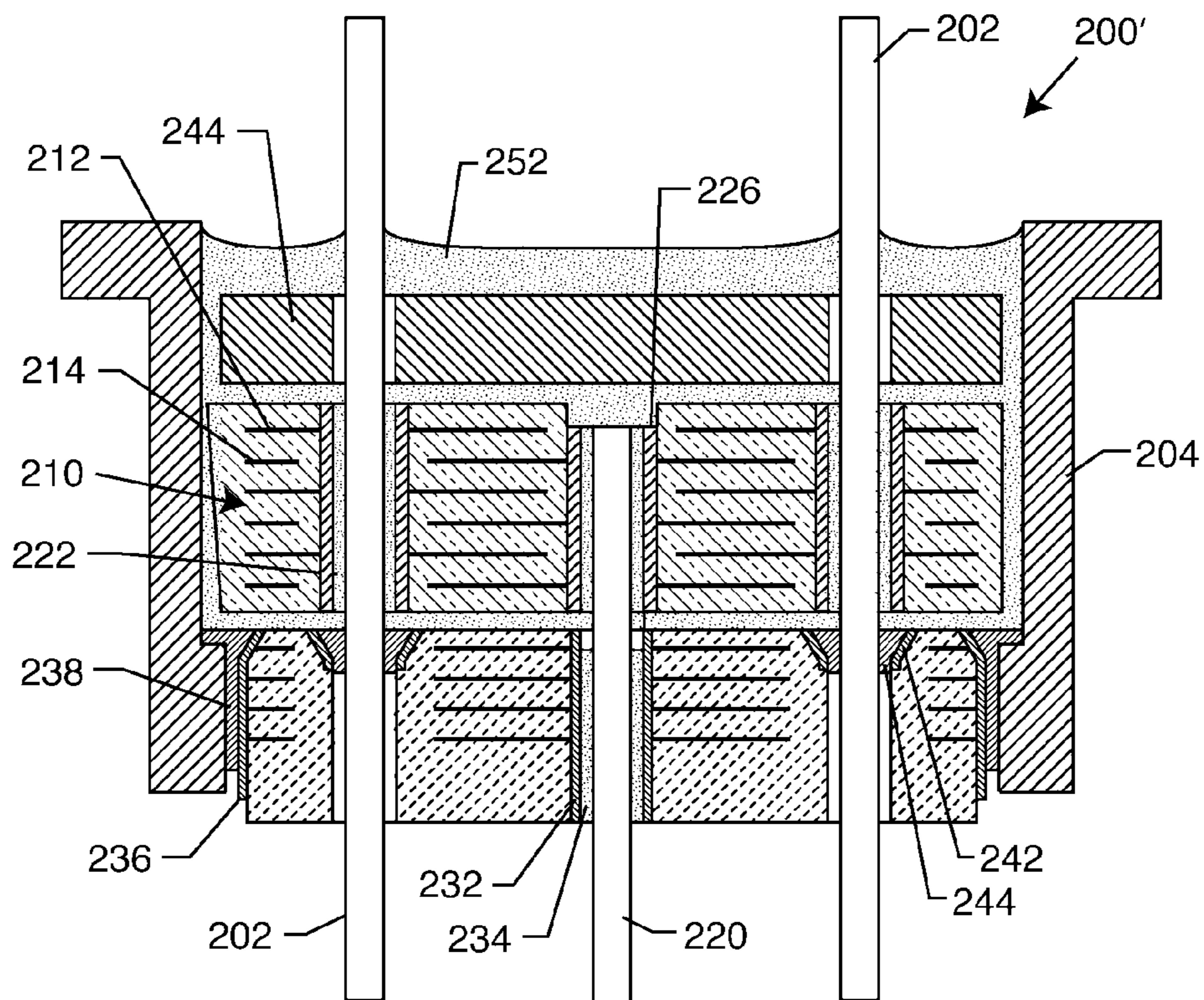

FIG. 9

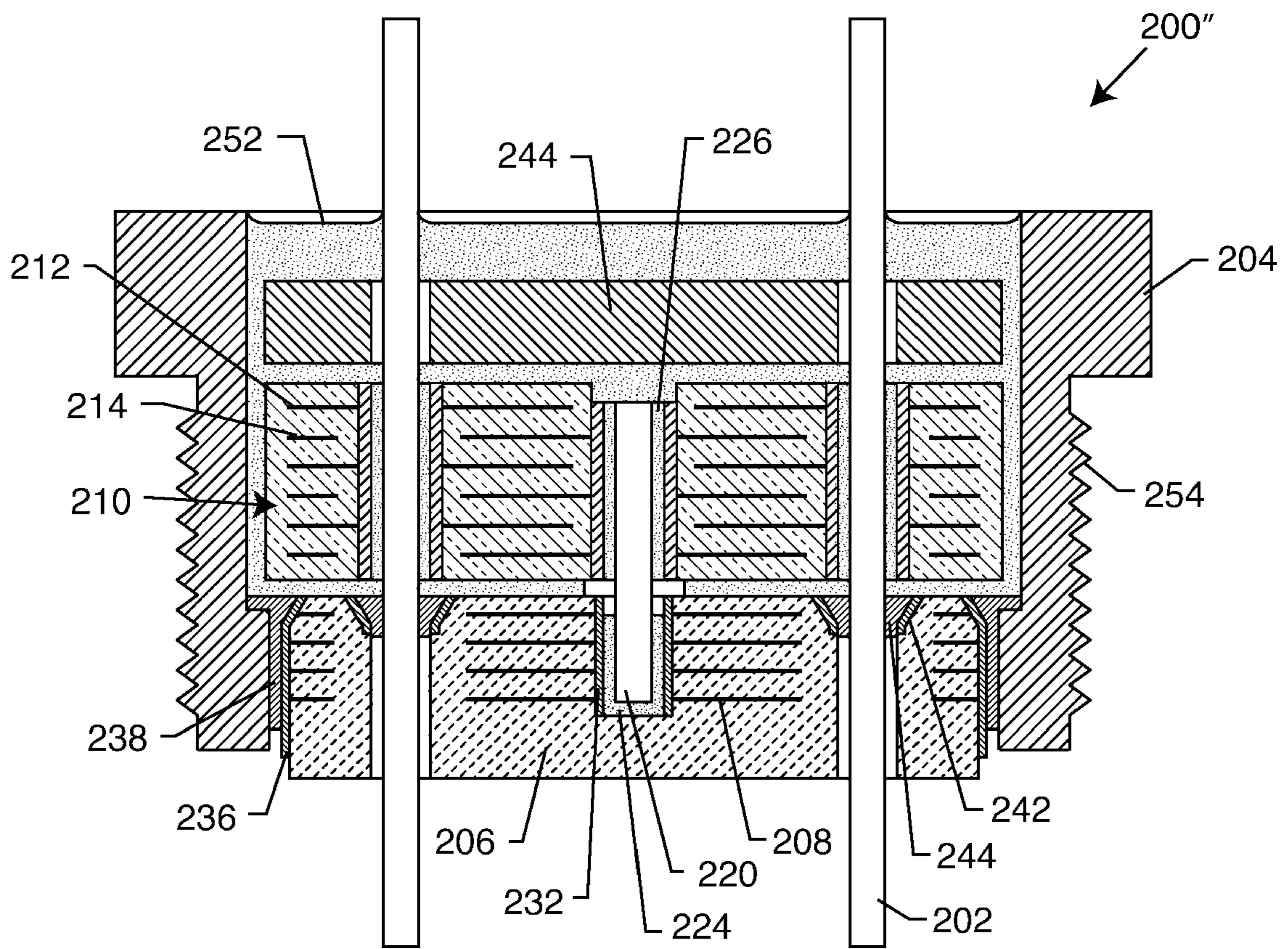

FIG. 10



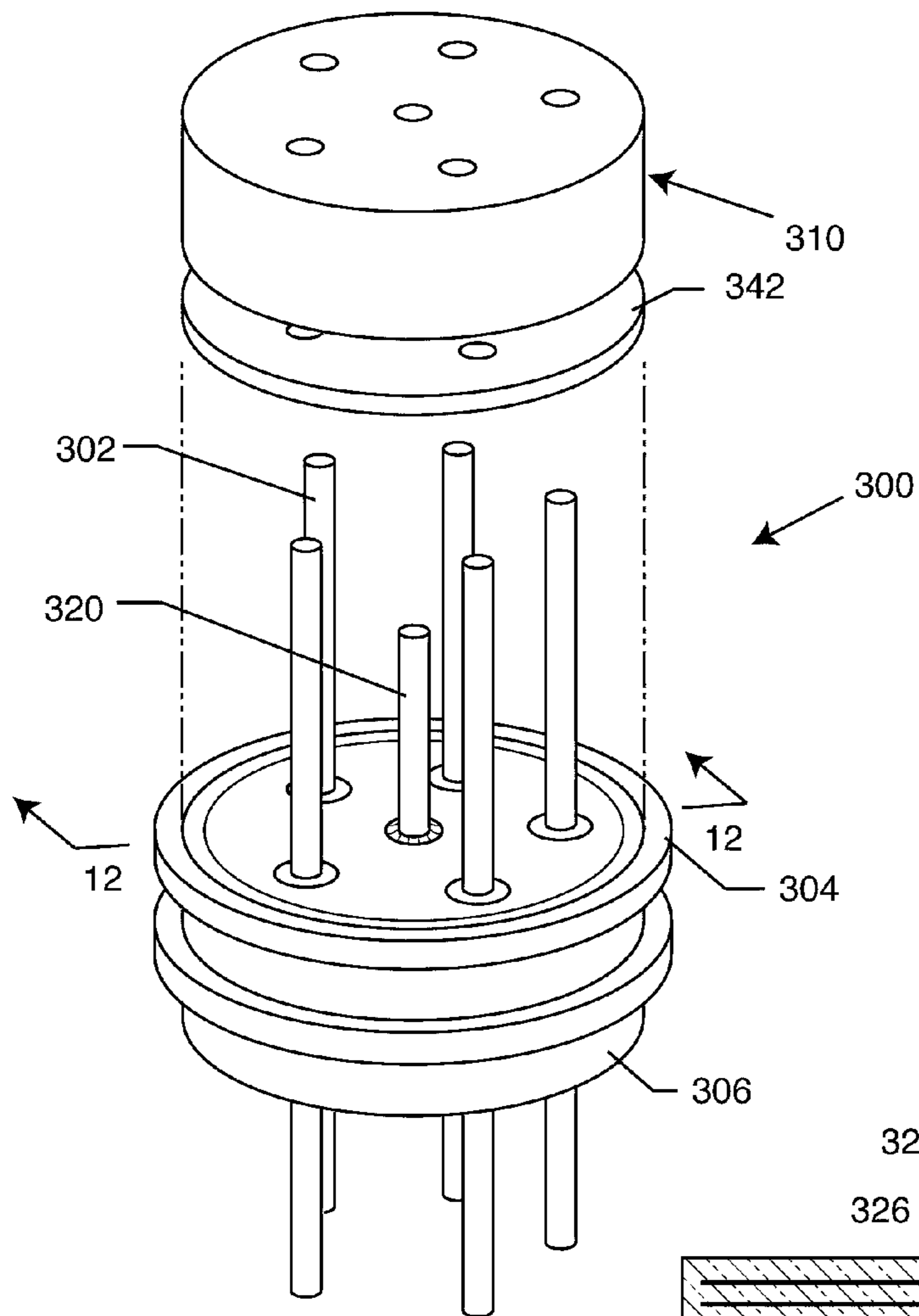

FIG. 11

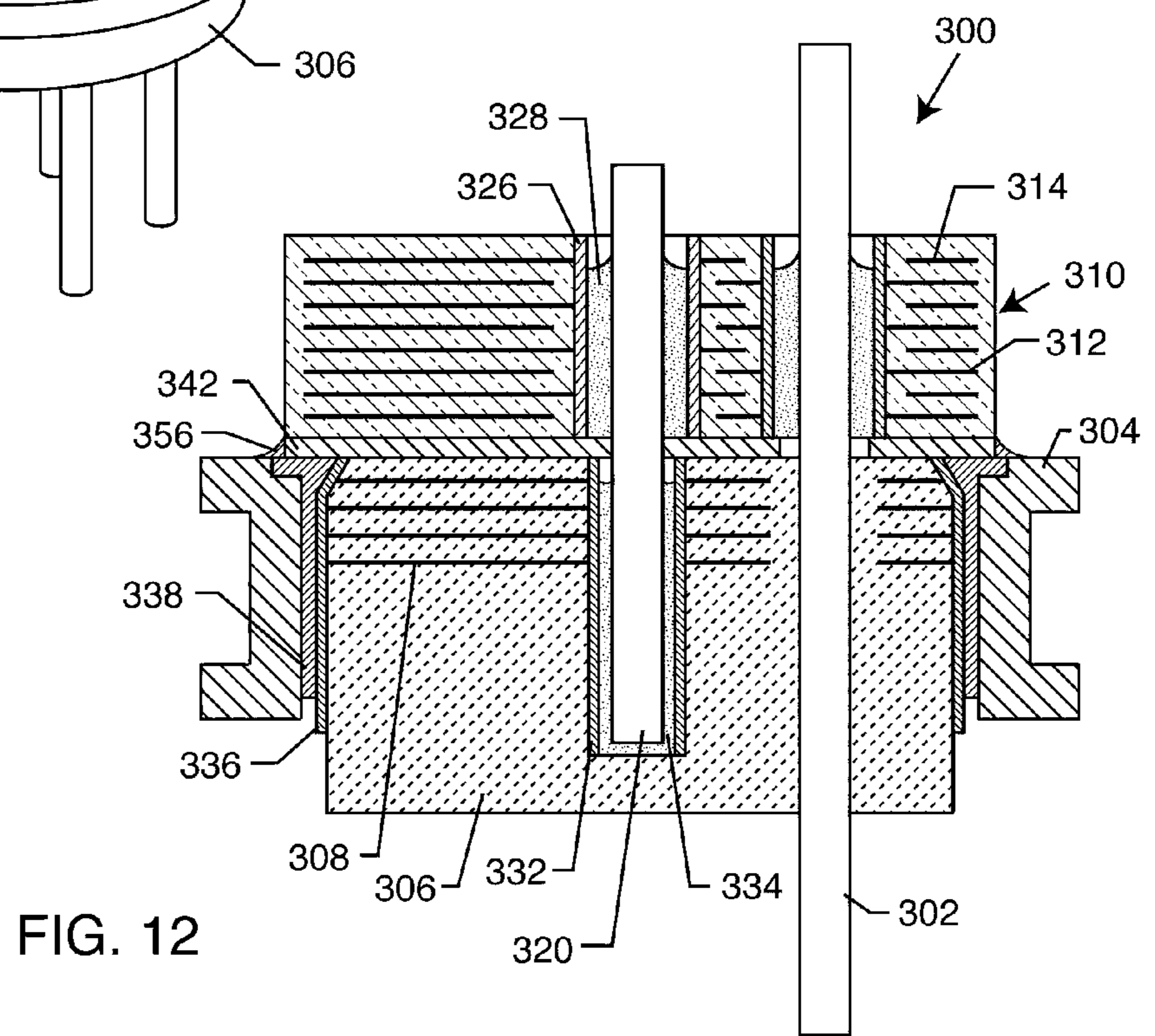

FIG. 12

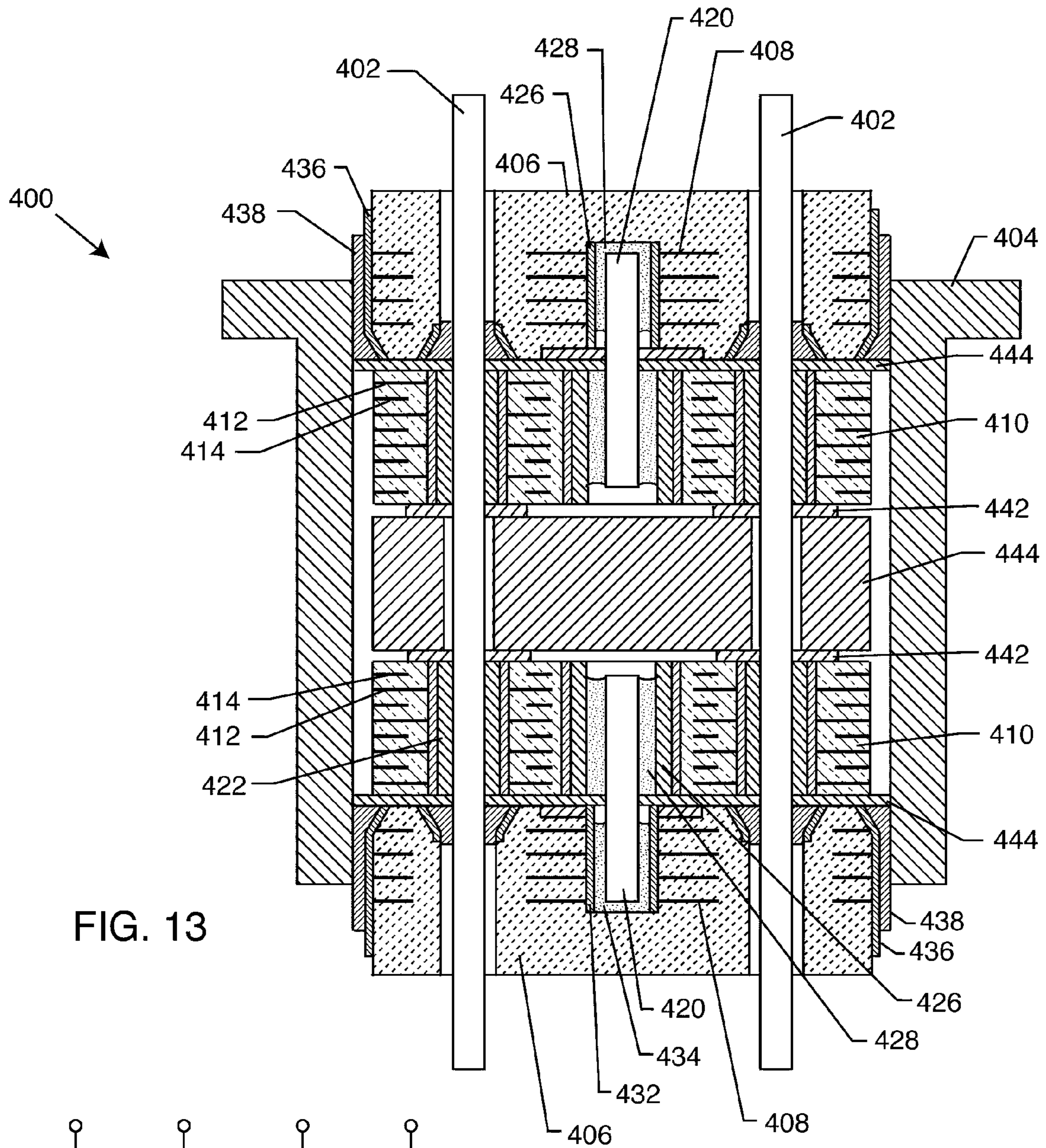

FIG. 13

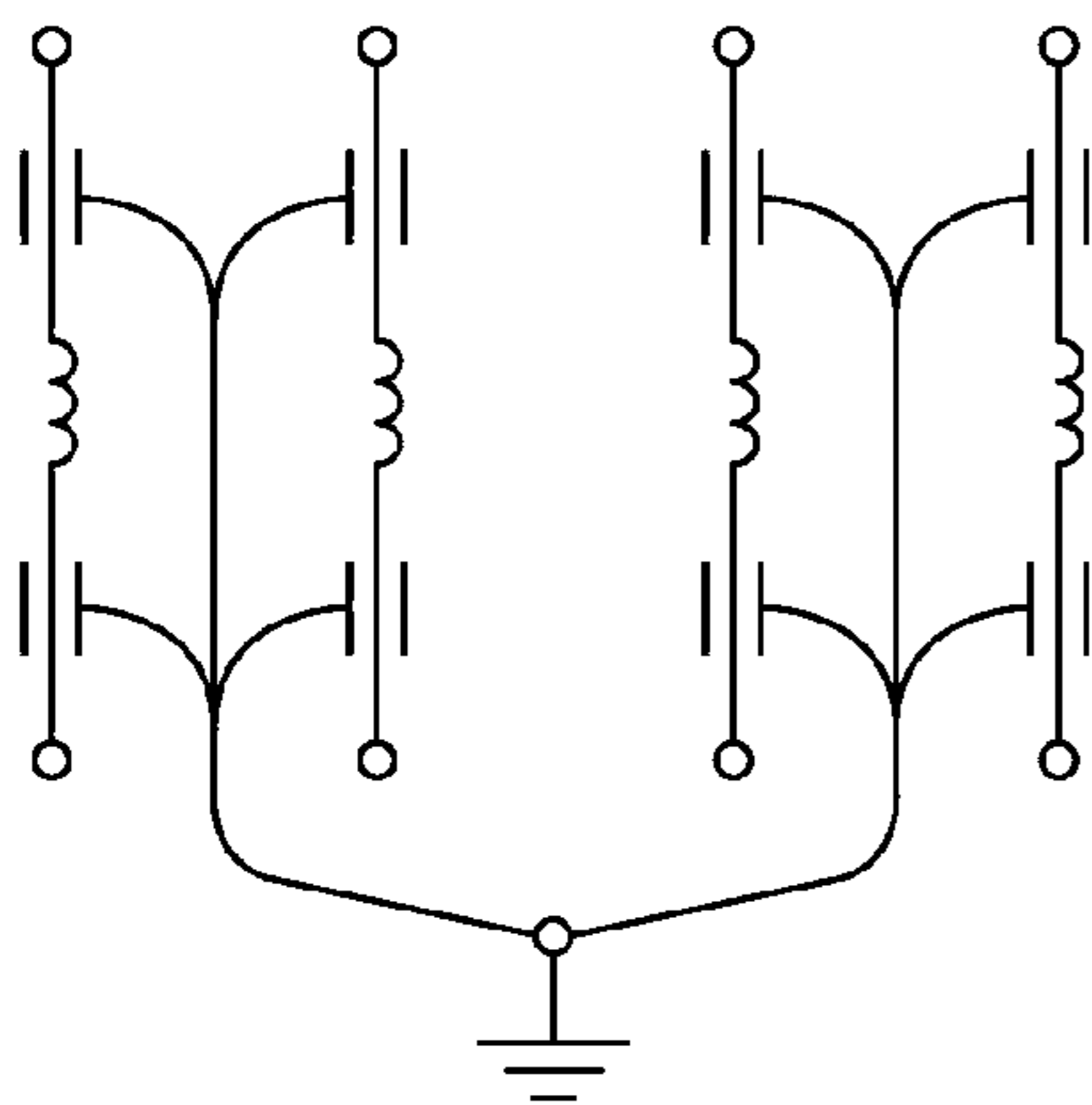

FIG. 14

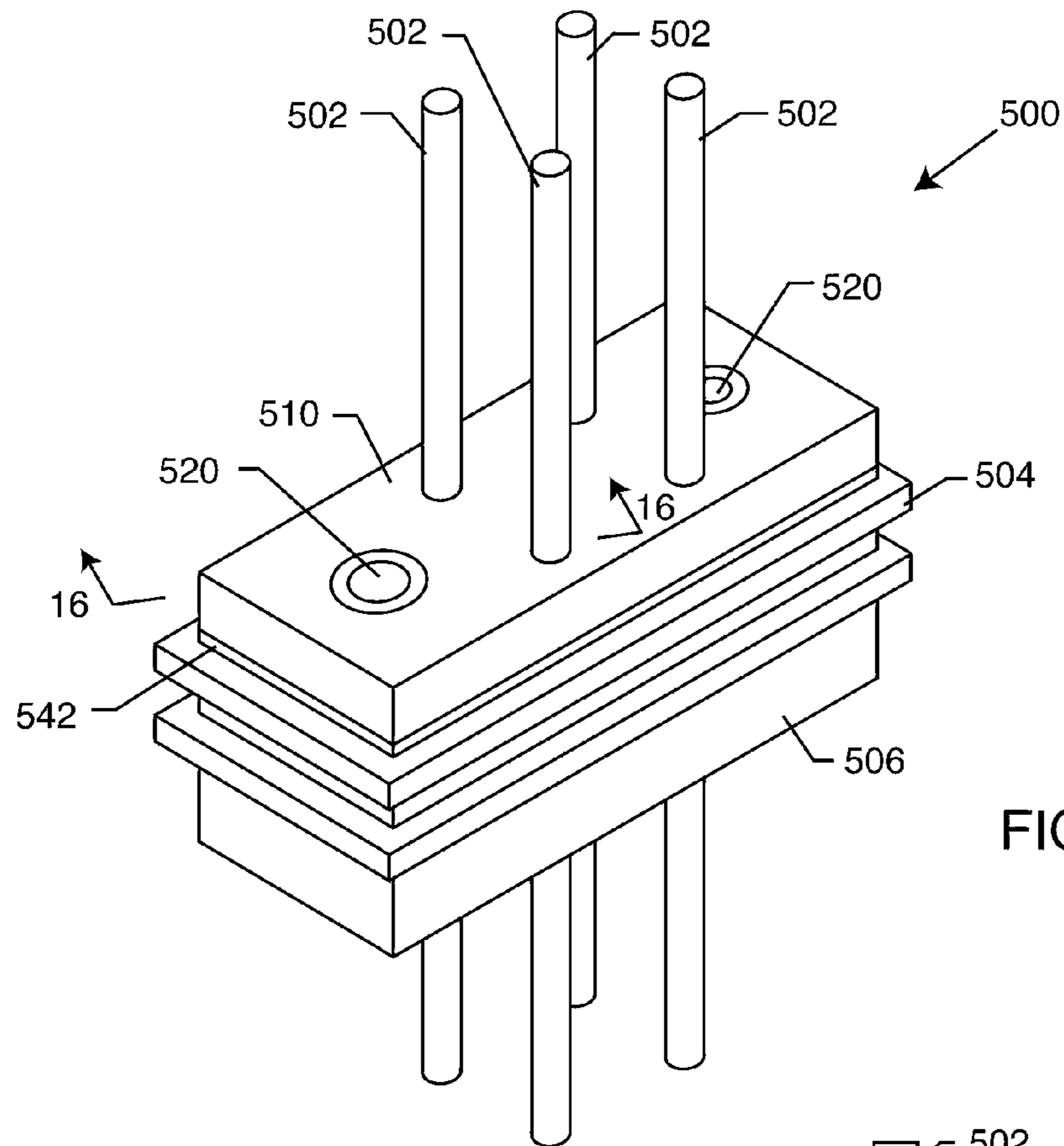

FIG. 15

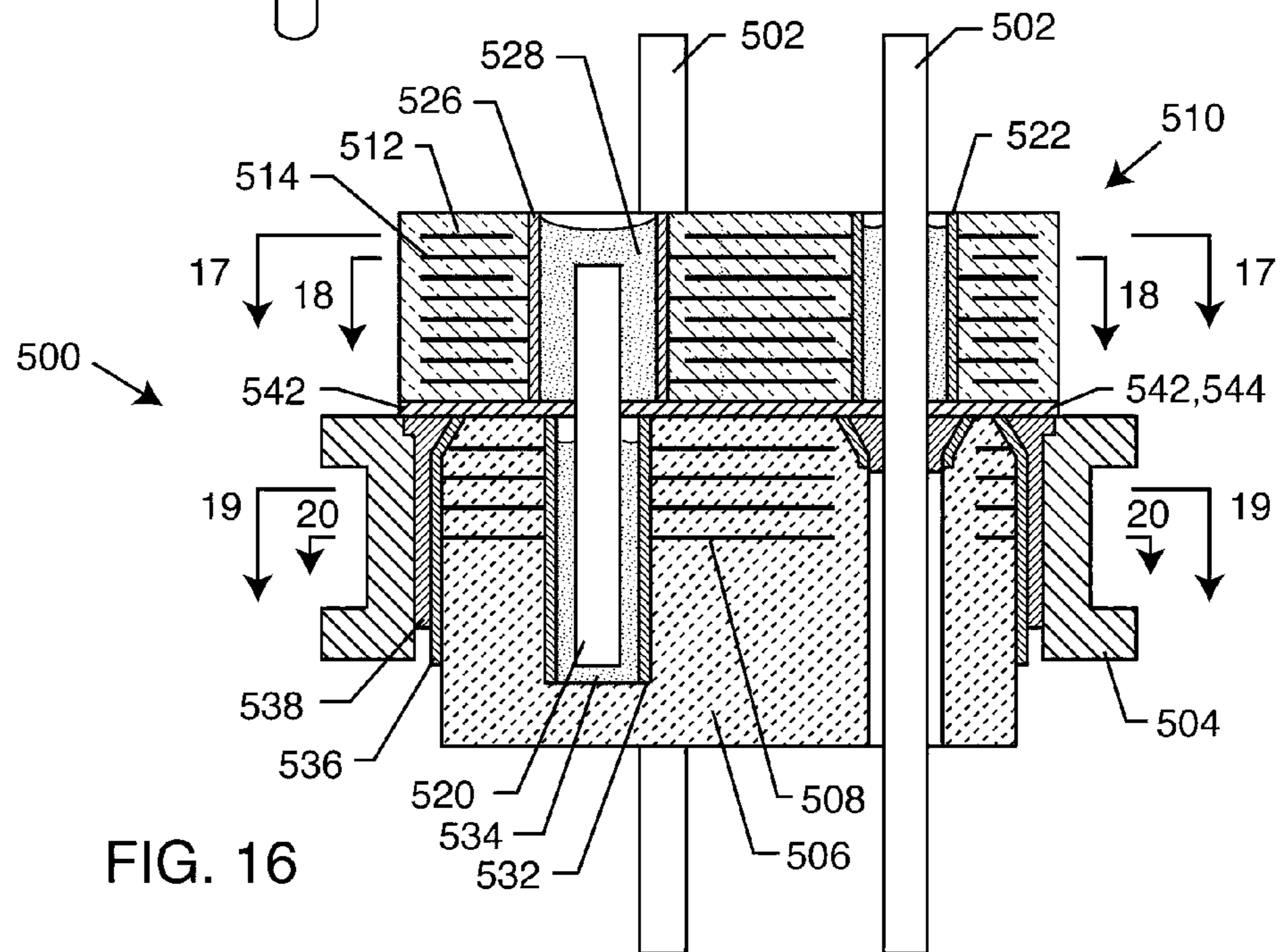

FIG. 16

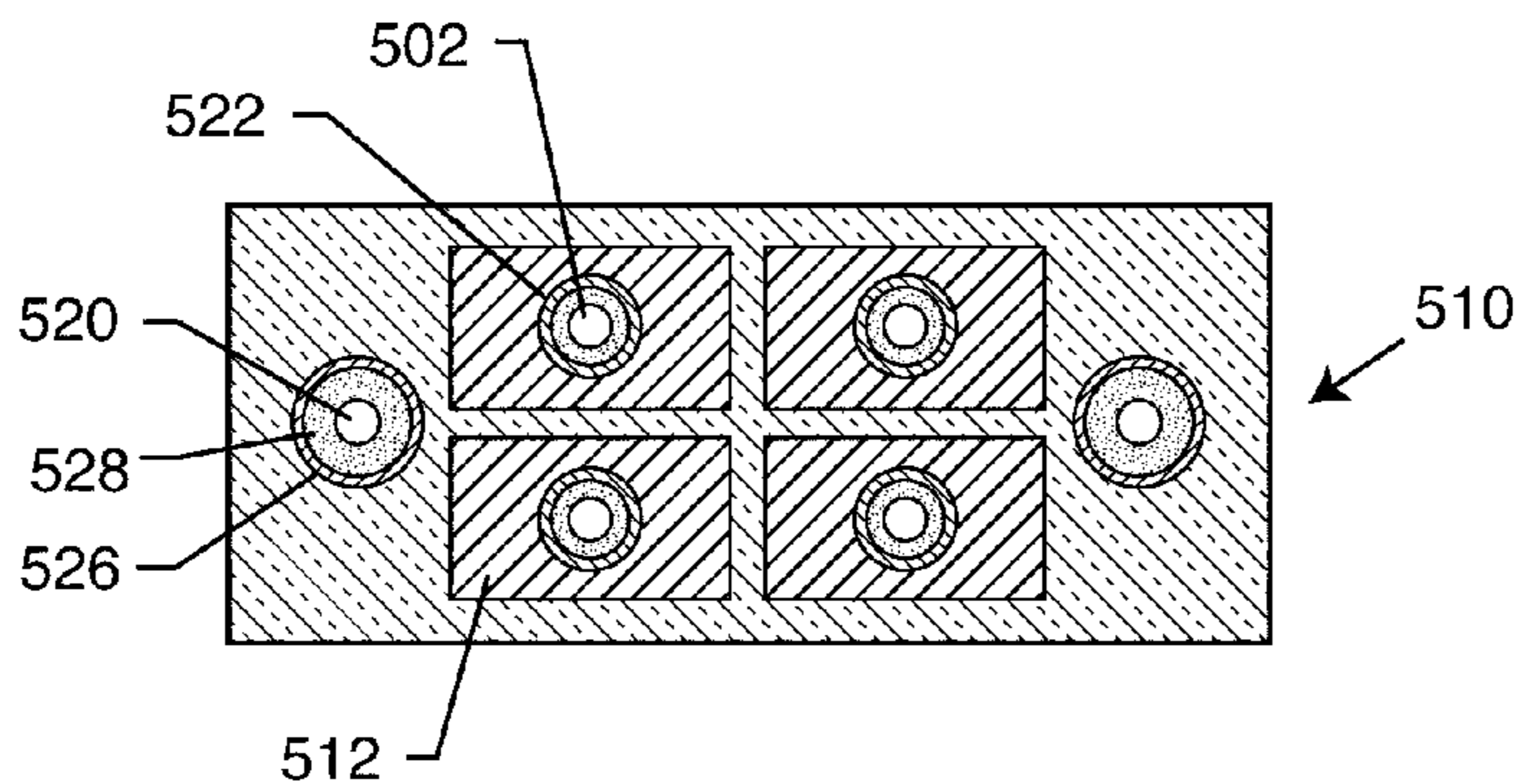

FIG. 17

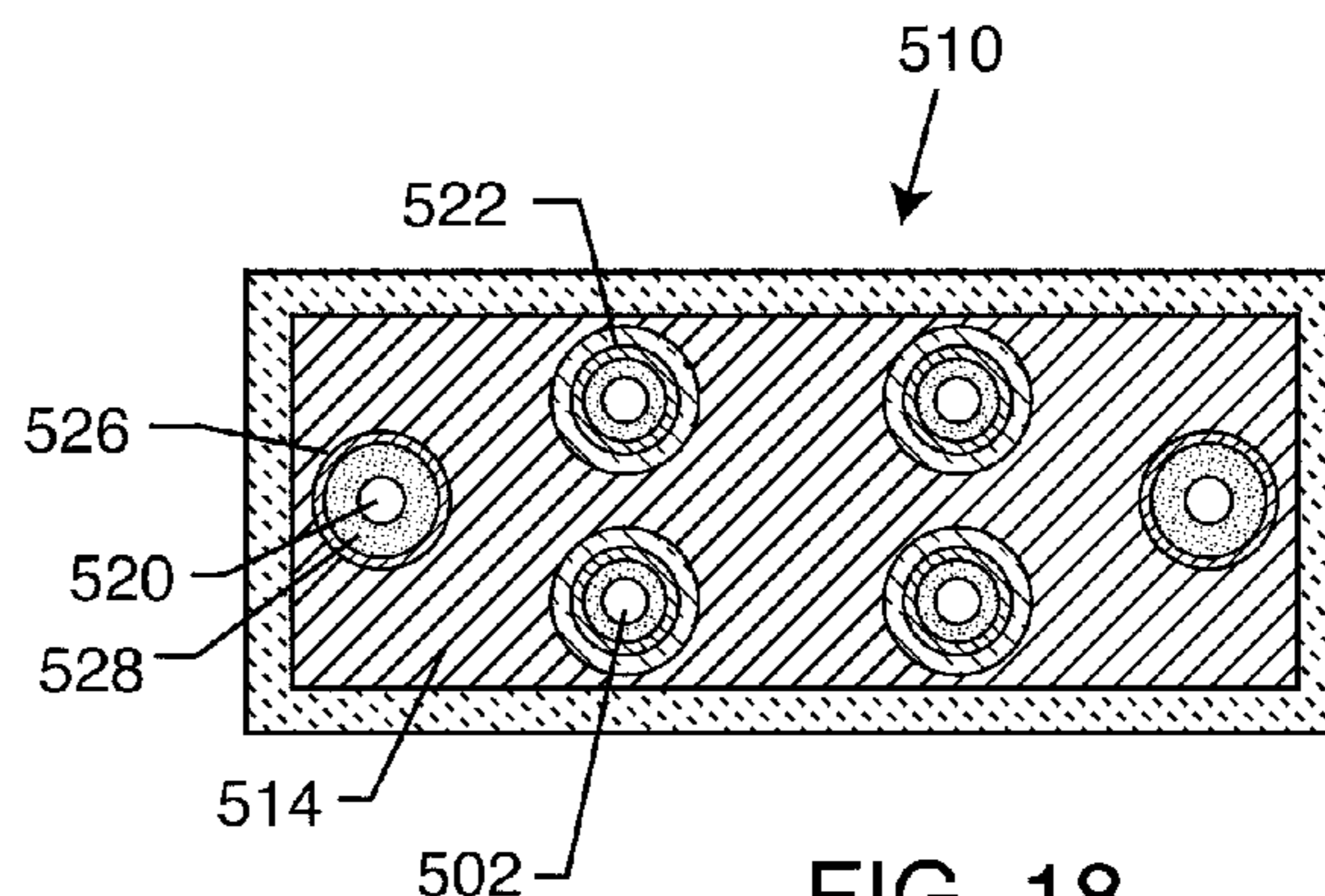

FIG. 18

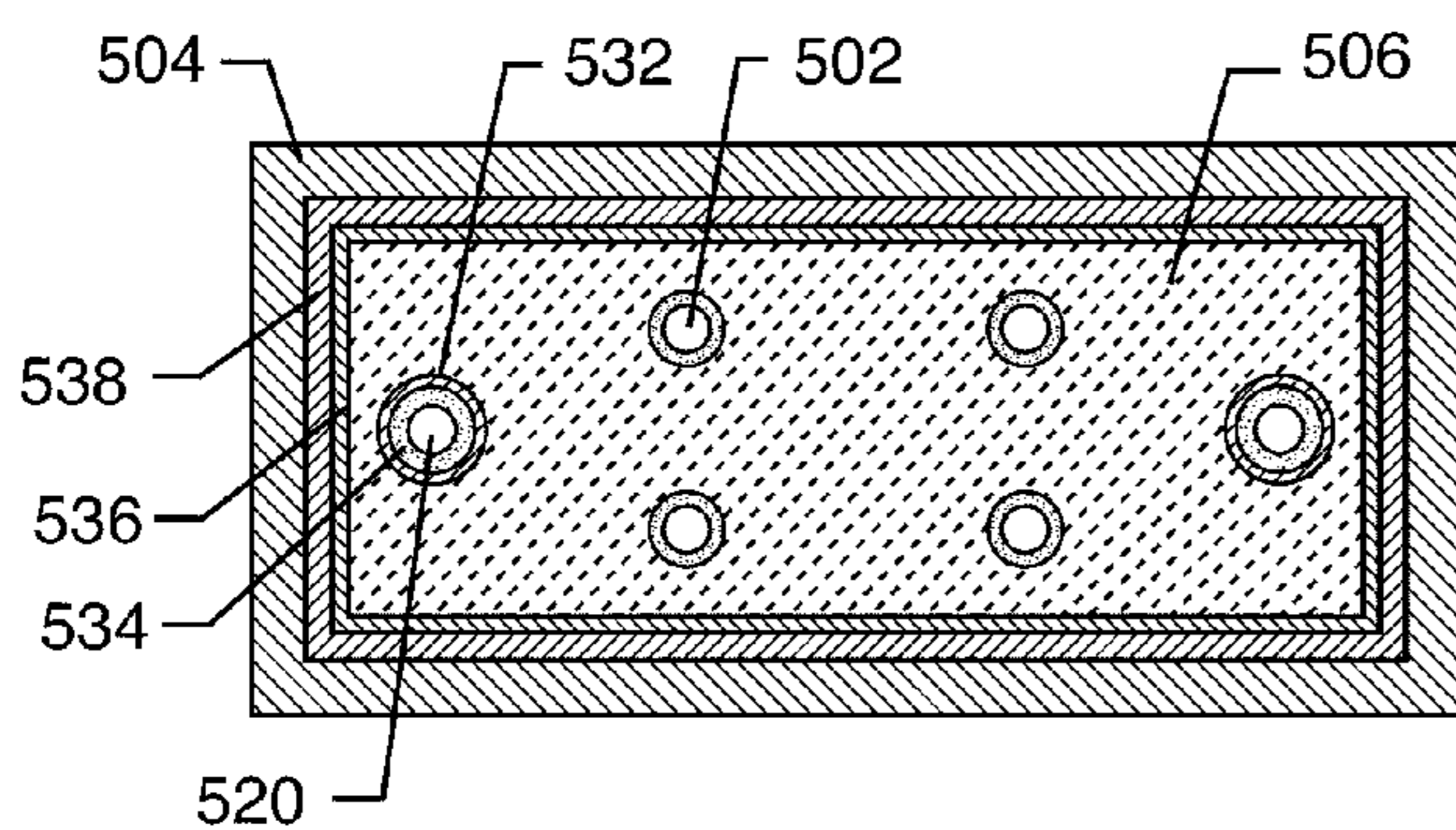

FIG. 19

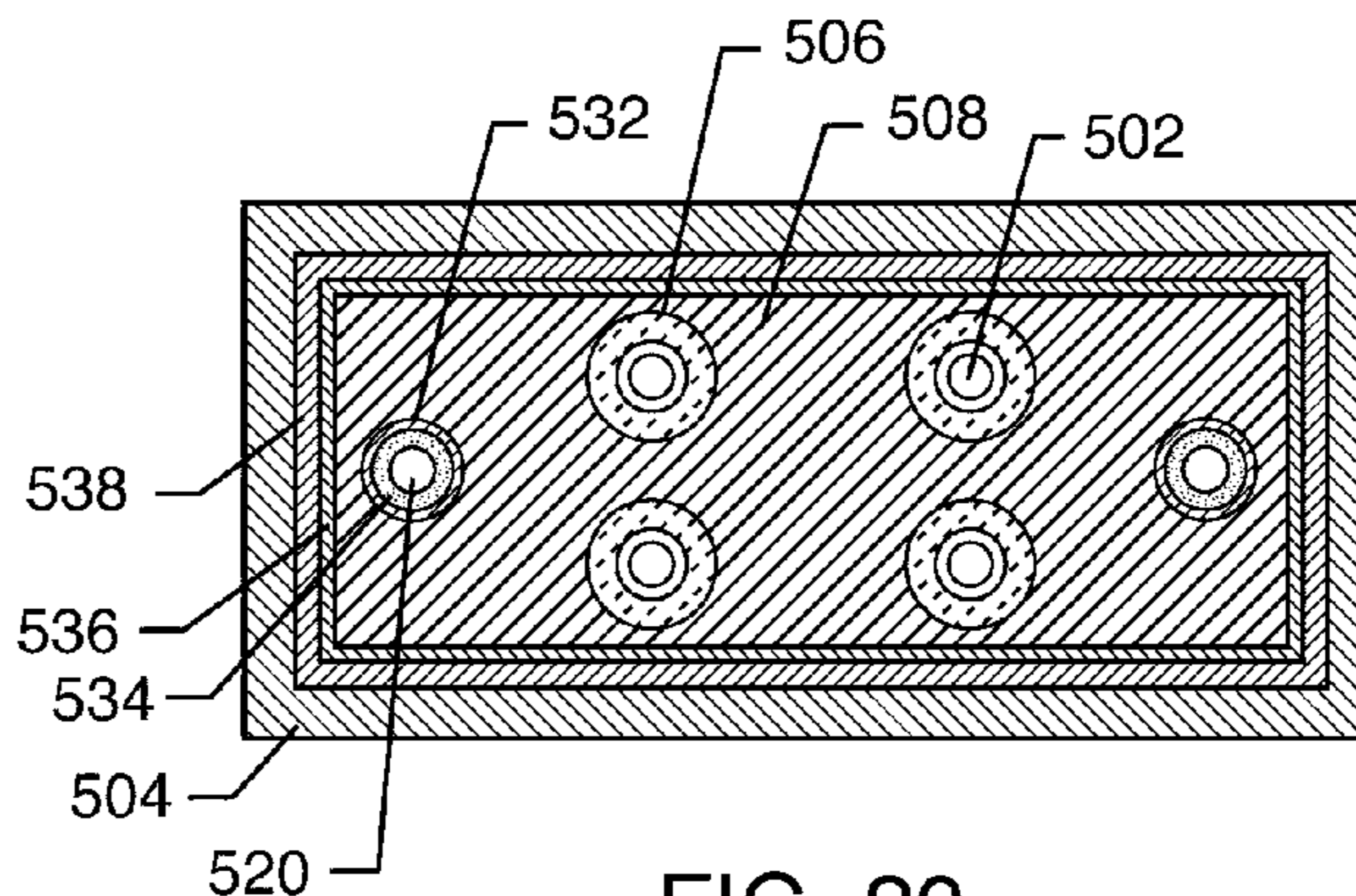

FIG. 20

**FEEDTHROUGH FILTER CAPACITOR  
ASSEMBLY WITH INTERNALLY  
GROUNDED HERMETIC INSULATOR**

**Matter enclosed in heavy brackets [ ] appears in the original patent but forms no part of this reissue specification; matter printed in italics indicates the additions made by reissue; a claim printed with strikethrough indicates that the claim was canceled, disclaimed, or held invalid by a prior post-patent action or proceeding.**

BACKGROUND OF THE INVENTION

The present invention relates generally to improved feedthrough terminal pin sub-assemblies and related methods of construction, particularly of the type used in active implantable medical devices, to decouple and shield undesirable electromagnetic interference (EMI) signals from the device. More particularly, the present invention relates to a reduced cost and reduced mechanical stress hermetic feedthrough terminal pin and ceramic feedthrough capacitor assembly which does not require an outer electrical connection between the one or more capacitors and a ferrule or device housing ground. It is adapted particularly for use in connecting one or more lead wires or conductive terminal pins through a hermetically sealed housing to internal electronic components of the medical device while decoupling EMI against entry into the sealed housing. The present invention is specifically designed for use in active implantable medical devices, such as cardiac pacemakers, implantable defibrillators, hearing implants, neuro-stimulators, drug pumps, bone growth stimulators, and the like.

Feedthrough terminal pin assemblies are generally well known in the art for connecting electrical signals through the housing or case of an electronic instrument. For example, in implantable medical devices such as cardiac pacemakers, defibrillators or the like, the terminal pin assembly comprises one or more conductive terminal pins supported by an insulator structure for feedthrough passage from the exterior to the interior of the medical device. Many different insulator structures and related mounting methods are known in the art for use in medical devices wherein the insulator structure also provides a hermetic seal to prevent entry of body fluids into the housing of the medical device. Said hermetic insulators for medical implant applications are typically constructed of alumina ceramic or glass wherein the terminal pins and ferrule are of suitable biocompatible material such as platinum, platinum-iridium, niobium, tantalum or titanium, respectively. However, the feedthrough terminal pins are typically connected to one or more exterior lead wires, for example, the leads which connect a cardiac pacemaker to the ventricle chamber of the heart, can also effectively act as an antenna and thus tend to collect stray EMI signals for transmission into the interior of the medical device. In many prior art devices, the hermetic terminal pin assembly has been combined directly with a ceramic feedthrough filter capacitor to decouple interference signals to the housing of the medical device.

In a typical unipolar construction, as described in U.S. Pat. No. 5,333,095 (the contents of which are incorporated herein), a coaxial ceramic feedthrough filter capacitor used in a feedthrough assembly to suppress and decouple undesired interference or noise transmission along a terminal pin comprises a so-called discoidal capacitor having two sets of electrode plates embedded in spaced relation within an insulative dielectric substrate or base, formed typically as a

ceramic monolithic structure. One set of the electrode plates is electrically connected at an inner diameter cylindrical surface of the discoidal capacitor structure to the conductive terminal pin utilized to pass the desired electrical signal or signals. The other or second set of electrode plates is coupled at an outer diameter surface of the discoidal capacitor to a cylindrical ferrule of conductive material, wherein the ferrule is electrically connected in turn to the conductive housing of the electronic device. The number and dielectric thickness spacing of the electrode plate sets varies in accordance with the capacitance value and the voltage rating of the discoidal capacitor. In operation, the discoidal capacitor permits passage of relatively low frequency biological electrical signals along the terminal pin, while shielding and decoupling/attenuating undesired interference signals of typically high frequency to the conductive housing.

Feedthrough capacitors of this general type are available in unipolar (one), bipolar (two), tripolar (three), quadpolar (four), pentapolar (five), hexpolar (six) and additional lead configurations. The feedthrough capacitors of this general type are commonly employed in implantable cardiac pacemakers, defibrillators, and the like, wherein the pacemaker housing is constructed from a biocompatible metal, such as titanium alloy, which is electrically coupled to the second electrode plate set of the feedthrough filter capacitor. As a result, the filter capacitor and terminal pin assembly prevents entrance of interference signals to the interior of the pacemaker housing, wherein such interference signals could otherwise adversely affect the desired cardiac pacing or defibrillation function.

In the past, feedthrough filter capacitors for cardiac pacemakers and the like have typically been constructed by preassembly of the discoidal capacitor within a cylindrical or rectangular terminal pin subassembly which includes the conductive pin and ferrule. More specifically, the terminal pin subassembly is prefabricated to include one or more conductive terminal pins supported within the conductive ferrule by means of a hermetically sealed insulator ring or bead. See, for example, the subassemblies disclosed in U.S. Pat. Nos. 3,920,888; 4,152,540; 4,421,947; and 4,424,551. An improved design which has substantially improved the volumetric efficiency is based upon surface mounting of a ceramic feedthrough capacitor planar array structure to one outer surface of a hermetic terminal with similar connection to the conductive pins (see the subassemblies disclosed in U.S. Pat. No. 5,333,095). In all of the prior art described above, the outer feedthrough capacitor electrode plate sets are coupled in parallel together by a metallized layer which is either fired, sputtered or plated onto the ceramic capacitor. This metallized band, in turn, is coupled to the ferrule by conductive adhesive, soldering, brazing, or the like.

Although feedthrough filter capacitor assemblies of the type described above have performed in a generally satisfactory manner, the manufacture and installation of such filter capacitor assemblies has been relatively time consuming and therefore costly. For example, installation of the discoidal capacitor into the small annular space described by U.S. Pat. No. 4,424,551 between the terminal pin and ferrule can be a difficult and complex multi-step procedure to ensure formation of reliable, high quality electrical connections. The method taught by U.S. Pat. No. 4,424,551 (the contents of which are incorporated herein), teaches the injection of fluidic thermosetting conductive particles into first and second annular cavities (usually by centrifuge operations). As a consequence, this method also requires insulation of the interface between the capacitor structure and insulator, curing of the various thermosetting materials, and subsequent

cleaning operations to remove excess conductive material. While the method taught by U.S. Pat. No. 5,333,095 is far simpler, a connection from the capacitor outside diameter and the conductive ferrule is still required.

A significant advance in the state of the art is described by internally grounded feedthrough capacitors as described in U.S. Pat. Nos. 5,905,627 and 6,529,103. These patents describe a methodology wherein it is not necessary to form a direct electrical connection between the outside diameter metallization of the feedthrough capacitor and the ferrule of the hermetic terminal of the implantable medical device. The internal ground technology teaches grounding of the second set of electrode pins through one or more grounded terminal pins. This has a significant advantage in that the elimination of the electrical and mechanical connection from the capacitor outside diameter or perimeter acts to significantly reduce the thermal and mechanical stress that is transmitted to the rather fragile feedthrough capacitor during the installation of the hermetic terminal pin assembly into the housing of the active implantable medical device by laser welding or the like. A significant number of EMI filtered hermetic terminals used in cardiac pacemakers and implantable defibrillators are manufactured using an internally grounded feedthrough capacitor. This has become a very popular and cost effective way of manufacturing such terminals. However, a significant cost driver is the need to provide one or more grounded pins for coupling to the second set of capacitor electrode plates. The present invention describes a novel method of providing internally grounded electrode plates within the hermetic terminal insulator itself. As will be further described herein, such internal ground plates within the insulator can be used to conveniently ground one or more terminal pins to couple to the second electrode plate set of the internally grounded capacitor.

A high integrity hermetic seal for medical implant applications is very critical to prevent the ingress of body fluids into the implanted device (e.g. pacemaker). Even a small leak rate of such body fluid penetration can, over a period of many years, cause moisture to build up and damage sensitive internal electronic components. This can cause catastrophic failure of the implanted device. The hermetic seal for medical implant applications is typically constructed of highly stable alumina ceramic or glass materials with very low bulk permeability.

Withstanding the high temperature and thermal stresses associated with the welding of a hermetically sealed terminal with a premounted ceramic feedthrough capacitor is very difficult to achieve with the prior art designs. The electrical/mechanical connection to the outside perimeter or outside diameter of the feedthrough capacitor has a very high thermal conductivity as compared to air. The hermetic bonding operation typically employed in the medical implant industry to install the filtered hermetic terminal into the implantable device housing generally involves a laser welding operation in very close proximity to this electrical/mechanical connection area. Accordingly, in the prior art, the ceramic feedthrough capacitor is subjected to a dramatic temperature rise. This temperature rise produces mechanical stress in the capacitor due to the mismatch in thermal coefficients of expansion of the surrounding materials. Many of these prior art devices employ a soldered connection to the outside perimeter or outside diameter of the feedthrough capacitor. Excessive installation soldering heat has been known to damage such devices.

The novel internally grounded feedthrough capacitors that are described by U.S. Pat. Nos. 5,905,627 and 6,529,103 solve these issues. By elimination of the outside diameter or

outside perimeter electrical/mechanical connection area, the thermal and mechanical stresses are greatly reduced. That is, during laser welding of the titanium flange into the housing of the implantable medical device, said titanium flange will tend to expand and contract greatly. This transmits stresses to the rather sensitive monolithic ceramic feedthrough capacitor. Accordingly, elimination of said mechanical and electrical connection is a highly desirable feature. The present invention describes a very novel and convenient way of making connection to the second set of electrode plates without creating additional mechanical stresses.

A major market force within the medical implantable device industry has been to reduce the cost of the implanted device (e.g. pacemaker or implantable cardioverter defibrillator). Medical insurance carriers, government healthcare programs (e.g. Medicare) and health maintenance organizations (HMOs) are placing additional competitive pressures on the manufacturers of such devices.

Accordingly, there is a need for a novel feedthrough filter capacitor assembly that addresses the drawbacks noted above in connection with the prior art. In particular, a novel capacitor assembly is needed that is subjected to far less temperature rise during the manufacture thereof by eliminating an outside perimeter or outside diameter electrical/mechanical connection. Such a design would allow the use of much lower temperature materials (such as standard solder) to achieve the capacitor inside diameter lead connections. Moreover, such an improvement would make the assembly relatively immune to the aforementioned stressful installation techniques. A novel filter capacitor design is needed which is of simplified construction, utilizing a straightforward and uncomplicated feedthrough terminal pin subassembly that can result in manufacturing cost reductions. Of course the new design must be capable of effectively filtering out undesirable electromagnetic interference (EMI) signals from the target device. The present invention fulfills these needs and provides other related advantages.

#### SUMMARY OF THE INVENTION

The present invention resides in an improved internally grounded feedthrough filter capacitor assembly, wherein the capacitor assembly is subjected to far less temperature rise during the manufacture thereof by eliminating the outside perimeter or outer surface electrical/mechanical connection. The design of the present invention is capable of effectively filtering out undesirable EMI signals from the target device, while eliminating stressful installation techniques and resulting in size and manufacturing cost reductions.

The feedthrough filter capacitor assembly of the present invention generally comprises an internally grounded feedthrough filter capacitor having first and second electrode plates. A first passageway is formed through the capacitor through which a terminal pin extends in conductive relation with the first set of electrode plates. The terminal pin also extends through a conductive ferrule and an insulator in non-conductive relation. The insulator includes a ground plate conductively coupled to the ferrule. Means are provided for conductively coupling the capacitor second set of electrode plates and the insulator ground plates.

Typically, the ferrule is conductively coupled to a housing for an active implantable medical device, such as a cardiac pacemaker, an implantable defibrillator, a congestive heart failure device, a hearing implant, a cochlear implant, a neurostimulator, a drug pump, a ventricular assist device, an insulin pump, a spinal cord stimulator, an implantable sensing system, a deep brain stimulator, an artificial heart, an

incontinence device, a vagus nerve stimulator, a bone growth stimulator, a gastric pacemaker, or a prosthetic device.

The present invention, however, is not limited strictly to implantable medical devices. It also has broad application to military, space, external medical, telecommunications, and other applications. It will be obvious to those skilled in the art, that anytime that a hermetic seal is utilized to protect the internal electronic packaging, that the invention described herein provides significant advantages.

The insulator ground plate set typically extends to a conductive outer peripheral surface of the insulator, which is conductively coupled to the ferrule. In a particularly preferred embodiment, the insulator ground plate comprises a set of ground plates.

The coupling means, in a particularly preferred embodiment, includes a conductive material at least partially extending into a second passageway of the capacitor in conductive relation with the second set of electrode plates. The conductive material also at least partially extends through a second passageway of the insulator so as to be in conductive relation with the ground plates. Thus, any EMI is transferred from the conductive terminal pin to the first set of electrode plates, to the second set of electrode plates, and to the set of ground plates of the insulator (such as by the conductive material, and then to the ferrule and housing of the active implantable medical device. The conductive material may comprise one or more ground pins, a ground wire, a solder material, a conductive thermosetting material, a weld, a braze, a conductive glass, or a conductive spring coil such as that shown and described in U.S. patent application Ser. No. 10/907,361, filed Mar. 30, 2005.

Preferably, the outer peripheral surface of the capacitor is non-conductive and no conductive electrical/mechanical connection is made between it or the ferrule or active implantable medical device housing or the like.

The ground plates which are integral to the insulator structure of the hermetic terminal can be constructed of a number of materials. For example, if the insulator is alumina ceramic, the embedded ground electrode plates can be of the group of silver, palladium silver, platinum, platinum alloys and many other materials that are common in the art. Multi-layer alumina substrates, for example, are very common in circuit board or substrate manufacturing. It is also a novel feature of the present invention that said electrode plates could be made of ferro-magnetic materials. For example, the ground electrode plates could be made of nickel. This has desirable advantages to provide not just a convenient means of providing a grounded pin to the feedthrough capacitor, but also importantly provides magnetic shielding for the device. This could be particularly important in an MRI environment where it is necessary to prevent saturation of a ferrite inductor in the presence of a main static magnetic field of a magnetic resonance imaging machine.

The assembly of the present invention may also include an inductor, such as a ferrite inductor slab, through which the terminal pin extends in non-conductive relation. Preferably, the inductor is disposed adjacent to the capacitor. The inductor may be disposed between the capacitor and the insulator. The capacitor and insulator are preferably disposed in relation to each other, such as being adjacent to each other, but separated by a non-conductive material. In this regard, the disclosure of U.S. patent application Ser. No. 10/825,900 filed Apr. 15, 2004 is incorporated by reference herein.

Other features and advantages of the present invention will become apparent from the following more detailed description, taken in conjunction with the accompanying drawings, which illustrate, by way of example, the principles of the invention.

#### BRIEF DESCRIPTION OF THE DRAWINGS

The accompanying drawings illustrate the invention. In such drawings:

FIG. 1 is a perspective view of an internally grounded quadpolar feedthrough filter capacitor embodying the present invention;

FIG. 2 is a cross-sectional view taken generally along line 2-2 of FIG. 1, illustrating a conductive ground pin conductively coupling ground electrode plates of a capacitor and ground plates of an insulator, in accordance with the present invention.

FIG. 3 is a cross-sectional view taken generally along line 3-3 of FIG. 2, illustrating a ground plate of the insulator;

FIG. 4 is a side perspective view of the insulator of FIG. 2;

FIG. 5 is a cross-sectional view taken generally along line 5-5 of FIG. 2, illustrating an active electrode plate of the capacitor;

FIG. 6 is a cross-sectional view taken generally along line 6-6 of FIG. 2, illustrating a ground electrode plate of the capacitor;

FIG. 7 is an electrical schematic representation illustrating the filtering characteristics of the assembly of FIG. 1;

FIG. 8 is a cross-sectional view of a multi-polar capacitor feedthrough assembly incorporating the teachings of the present invention;

FIG. 9 is a cross-sectional view similar to FIG. 8, with a ground pin thereof only partially extending into a capacitor of the assembly;

FIG. 10 is a cross-sectional view of another feedthrough filter capacitor assembly, illustrating a ground pin thereof partially extending both into the capacitor and insulator so as to conductively couple ground plates thereof;

FIG. 11 is a partially exploded perspective view of a pentapolar feedthrough capacitor assembly embodying aspects of the present invention;

FIG. 12 is a cross-sectional view taken generally along line 12-12 of FIG. 11;

FIG. 13 is a cross-sectional view of a soldered-in quadpolar internally grounded PI filter EMI filter assembly embodying aspects of the present invention;

FIG. 14 is an electrical schematic representation for the assembly of FIG. 13;

FIG. 15 is a perspective view of a rectangular internally grounded quadpolar feedthrough filter capacitor assembly embodying aspects of the present invention, and including two conductive ground pins;

FIG. 16 is a cross-sectional view taken generally along line 16-16 of FIG. 15, illustrating internal components of the assembly;

FIG. 17 is a cross-sectional view taken generally along line 17-17 of FIG. 16, illustrating active electrode plates of the capacitor of the assembly;

FIG. 18 is a cross-sectional view taken generally along line 18-18 of FIG. 16, illustrating a ground electrode plate of the capacitor;

FIG. 19 is a cross-sectional view taken generally along line 19-19 of FIG. 16, illustrating passage of the terminal pins through the insulator, in accordance with the present invention; and

FIG. 20 is a cross-sectional view taken generally along line 20-20 of FIG. 16, illustrating conductive coupling of two ground pins with a ground plate of the insulator, in accordance with the present invention.

#### DETAILED DESCRIPTION OF THE PREFERRED EMBODIMENTS

As shown in the drawings, for purposes of illustration, the present invention is concerned with novel internally grounded feedthrough filter capacitor assemblies, generally designated in FIGS. 1-7 by the reference number 100, in FIGS. 8-10 by the reference 200, in FIGS. 11-12 by the reference number 300, in FIGS. 13-14 by the reference number 400, and in FIGS. 17-21 by the reference number 500. In the following description, functionally equivalent elements of the various embodiments share the same reference number in increments of 100.

Referring initially to FIGS. 1-7, the improved feedthrough filter capacitor assembly 100 comprises, generally, a plurality (in this case four) conductive terminal pins (102) which extend through a conductive ferrule 104, in non-conductive relation, as will be more fully described herein. An insulator 106 (FIGS. 2 and 4) supports each conductive terminal pin relative to the conductive ferrule 104 in electrically insulated relation. The insulator 106 is typically comprised of an alumina ceramic material, although it is not limited to such. However, the insulator 106 must be comprised of an electrically non-conductive material. The alumina insulator 106 includes at least one embedded monolithic ground plate 108 (see FIG. 3), and preferably a plurality of ground plates 108 spaced apart from one another to form a set, whose purpose will be described more fully herein.

The feedthrough filter capacitor assembly 100 further includes an internally grounded feedthrough filter capacitor 110 that has first and second sets of electrode plates 112 and 114 (FIGS. 2, 5 and 6). Passageways 116 are provided through the feedthrough filter capacitor 110 through which the terminal pins 102 extend in conductive relation with the first set of electrode plates 112. The feedthrough filter capacitor 110 further includes a second passageway 118 into which a conductive ground pin 120 extends in conductive relation to the second set of electrode plates 114.

In accordance with the present invention, the feedthrough filter capacitor 110 includes a monolithic, ceramic, internally grounded feedthrough filter capacitor having two or more (in this instance five) passageways extending therethrough. The outer four passageways are configured to receive therethrough the respective conductive terminal pins 102, and the internal diameter of the first passageways 116 are metallized (at 122) to form a conductive link between the first set of electrode plates 112 and the conductive terminal pins 102. A conductive polyimide fill, solder, or the like 124 is placed within the first passageways 116 between the metallization 122 and the respective terminal pin 102 to electrically link the terminal pin with the respective first set of electrode plates 112. As is well understood in the art, both sets of electrode plates 112, 114 are typically silk-screened onto ceramic plates, forming the feedthrough filter capacitor 110. These plates 112, 114 are surrounded by an insulative ceramic material that, for purposes of the present invention, need not be metallized on its exterior surfaces, as will be more fully discussed herein.

Similarly, the inner diameter of the central or second passageway 118 through the feedthrough filter capacitor 110 is also metallized (at 126) to conductively connect the second set of electrode plates 114, also referred to as the

ground plates of the feedthrough filter capacitor 110. As discussed above, the second passageway 118 is configured to receive therethrough the conductive ground pin 120. Again, a conductive polyimide, solder or other conductive fill 128 is placed within the second passageway 118 between the ground pin 120 and the metallization 126 to conductively couple the ground pin 120 to the second set of electrode plates 114.

In typical applications in the prior art, the second set of ground electrodes 114 extend to the outer periphery of the capacitor 110. The outer surface of the capacitor 110 is then metallized by metallization firing or plating operations, or otherwise providing external conductive connections between capacitor 110 and a ground, typically the conductive ferrule 104. However, as discussed previously, in addition to requiring extra manufacturing steps, forming such conductive connections places a great deal of stress on the capacitor 110 during the manufacturing process and also presents drawbacks of the joining of materials which are not perfectly matched in thermal coefficient of expansion.

The present invention, as described herein, eliminates the need for such external conductive connections between the capacitor 110 and the ferrule 104, or other ground. Typically, the conductive ferrule 104 is conductively mounted to a conductive substrate that may comprise, for example, the housing for an active implantable medical device. The ground pin 120, which is electrically and conductively coupled to the second set of electrode plates 114, as discussed above, extends into the insulator 106 so as to be conductively coupled with the one or more ground plates 108 of the insulator 106. More particularly, as illustrated in FIG. 2, the insulator 106 includes a passageway 130 adapted to receive the ground pin 120 therethrough. The ground plates 108 extend to the surface of this passageway 130, which is metallized (at 132) to conductively couple the ground plate 108 to one another. A conductive polyimide, solder, or other conductive fill 134 is placed within the passageway 130 to conductively couple the ground pin 120 to the ground plates 108.

The ground plates 108, as shown in FIGS. 2 and 3, extend to the outer peripheral surface of the insulator 106, which includes a metallization 136 (FIG. 4). This metallization 136 can be formed by any means, including electroplating, thick film deposition, sputtering, or the like. The metallization 136 is conductively coupled to the ferrule 104, such as through the use of a conductive pre-form, solder, weld, or the like 138. Thus, the second sets of electrode plates 114 of the feedthrough capacitor 110 are conductively coupled through the internal ground pin 120, which in turn is conductively coupled to the one or more ground plates 108 of the insulator 106, which are conductively coupled to the ferrule 104.

Passageways 140 are also formed through the insulator 106, in general alignment with the capacitor passageways 116, for passage of the first conductive pins 102 therethrough. Due to the non-conductive nature of the material comprising insulator 106, the pins 102 could pass through in a frictional fit manner. However, in a particularly preferred embodiment, an upper beveled portion of the passageway 140 is metallized (at 142) such that a metal pre-form, such as gold or the like, or solder 144 can securely and hermetically connect the terminal pin 102 to the insulator 106. However, the metallization 142 does not come into contact with the one or more ground plates 108. Thus, the conductive pins 102 are electrically isolated from the ground plates 108 and the ferrule 104.

With continuing reference to FIG. 2, the capacitor 110 and insulator 106 are typically disposed relatively adjacent to



one another and separated by a non-conductive material such as the illustrated washer **142**. The washer **142** provides an insulative barrier between the isolated feedthrough filter capacitor **110** and the mounting surface of the insulator **106**. The washer barrier **142** provides additional electrical isolation between the terminal pin **102** and ground pins **120**, and provides mechanical stability for environmental exposure such as vibration and mechanical shock. The insulating washer **142** may be constructed by punching, laser cutting, or pre-forming a non-conductive polyimide matrix to the proper shape and number of feedthrough holes used in a material such as Abel Bond 71-7. The insulating washer **142** may also be constructed of a non-conductive epoxy which has been formed into a B-staged pre-form.

An optional inductor **144** may be associated with the capacitor **110**, such as disposing the inductor **144** in between the capacitor **110** and the insulator **106**, as illustrated in FIG. 2. An insulative washer **146**, as described above, is disposed between the inductor **144** and the capacitor **110** to provide a physical separation between them. Passageways **148** are formed in the inductor **144**, as necessary, such that the conductive pins **102** and **120** pass therethrough. It will be understood by those skilled in the art that the assembly **100** may incorporate one or more ferrite inductors **144** in various EMI filter circuit configurations as needed or desired. The electrical schematic for the configuration of the assembly **100** in FIGS. 1 and 2 is illustrated in FIG. 7.

As shown in FIGS. 1 and 2, the ground pin **120** may extend well above the capacitor **110** surface if needed for convenient connection of an internal circuit or substrate to the ground (ferrule **104** or medical implant device housing). However, the ground pin **120** does not have to penetrate all the way through the insulator **106**.

With reference now to FIG. 8, the ground pin **220** may alternatively also extend through the insulator **206** to the body fluid side for convenient attachment to an electrode lead or the like. FIG. 8 illustrates a quadpolar internally grounded EMI filter capacitor **210** which is placed inside of a cylindrical cavity of a ferrule **204**. The assembly **200** may be installed so as to protrude from or into a titanium housing of an active implantable medical device. An optional insulative polymer fill **252** may be provided over the capacitor **210**, and inductor **244** if present, when installed within the ferrule **204**.

As described above, the ground pin **220** is in conductive relation with the second set of ground plates **214**, such as by use of a conductive polyimide, solder or other conductive fill **228** disposed between the ground pin **220** and the inner-metallization **226** of the passageway through the capacitor **210**. The conductive pins **202** are in conductive relation with the first set of electrode plates **212**, such as by contact with metallization **222** of the passageway. However, the terminal pins **202** are electrically isolated from the ground plates **208** of the insulator **206**, such as by the gold braze pre-form metallization **242** and gold braze connection **244**. The ground pin **220**, however, is conductively coupled with the ground plates **208** by either direct contact thereto or more typically via a conductive fill or solder **234** and an inner-metallization **232** which conductively couples the plates **208**. Similar to that described above, the plates **208** extend to an outer surface metallization **236**, which is conductively coupled to the ferrule **204** or other ground plane, such as by the conductive connection **238**, which may comprise a pre-form. The outer surface metallization **236** of the insulator **206** can be formed by many techniques, including metal deposition techniques, including flame spray, electric arc, chemical plating and electro plating techniques, as well

as silk screening and firing on a conductive glass frit matrix, conductive electrode ink or other metallic thick film.

With reference now to FIG. 9, another assembly **200'** is shown, similar to the assembly **200** of FIG. 8, but illustrating the ground pin **220** not penetrating all the way through the feedthrough filter capacitor **210**. In this case, the exposed upper portion of the pin **220**, and capacitor passageway is sealed with a non-conductive epoxy or polyimide **252**. Thus, in this case, the ground pin **220** does not extend into the device, but rather only towards the body fluid side of the assembly **200'**.

With reference now to FIG. 10, if the ground pin **220** need not extend beyond the capacitor **210** surface nor the insulator **206** surface, it can extend only partially or even fully through the capacitor **210** and insulator **206**, without being accessible for connection on either end, as illustrated in FIG. 10. The ground pin **220** still serves the purpose of internally grounding the capacitor **210**, as it is conductively coupled to the second set of ground electrode plates **214** and the ground plates **208** of the insulator **220**, which are conductively coupled to the ferrule **204**. In this assembly **200''**, the ferrule **204** includes external threads **254** for convenient screw-in installation into a threaded hole or into a bulk-head with a nut and lock washer of the medical device housing or the like. Optionally, a knurled surface (not shown) can be used for installation by pressing into a mating hole into the bulk head or plate. These configurations may be applicable to any of the ferrules illustrated if deemed necessary or desirable. Once again, the capacitor **210** "floats" within the ferrule **204** cavity in insulative relation to the alumina insulator **206**, protecting it from damage during assembly or installation.

Referring once again to FIG. 10, it is not necessary that the pin shown as **220** be a separate conductive lead wire. That is, pin **220** could be eliminated and instead the entire area could be filled with a thermal-setting conductive adhesive, a conductive polyimide, or the like, which is shown as material **224**. In other words, material **224** could simply fill the entire via hole between capacitor **210** and the internally grounded insulator **206**. Alternative materials also include the group of solders, conductive paste, brazes and welds.

With reference now to FIGS. 11 and 12, yet another assembly **300** embodying the present invention is shown. The assembly **300** comprises a pentapolar feedthrough filter assembly having an internal ground pin **320** conductively coupling the second set of capacitor electrode plates **314** to the ground plates **308** of the insulator **306** for grounding to the ferrule **304**. It will further be appreciated, as with the embodiments illustrated and described above, that the electrode patterns of both the first and second sets of electrode plates **312** and **314** do not extend to the outer diameter of the feedthrough capacitor **310**. This allows the outside surface of the feedthrough capacitor **310** to be non-conductive or insulative. In this embodiment **300**, the feedthrough capacitor **310** is fitted outside of the ferrule **304**, in this case, the capacitor **310** is separated by insulative barrier washer **342** from the alumina insulator **306**. The insulator **342** may be double-sided adhesive to adhere the capacitor **310** and insulator **306** to one another. A hermetic seal **356** may additionally be formed with braze, solder, adhesive or any other suitable material. As will be appreciated by those skilled in the art, the ground pin **320** is preferably generally centered with respect to the conductive terminal pins **302**, although, the invention is not limited to such a configuration.

With reference now to FIGS. 13 and 14, a PI ( $\pi$ ) circuit EMI feedthrough filter capacitor assembly **400** is illustrated. Here, two ground pins **420** are utilized with their respective pair of feedthrough capacitors **410** and insulators **406** con-

11

taining ground plates 408, as illustrated and described above. The pair of feedthrough capacitors 410 and insulators 406 are disposed on opposite sides of an intermediate inductor 444. The inductor 444, capacitors 410, and insulators 406 are separated by insulative washers 442 and 444. The electrical schematic for the assembly 400 is illustrated in FIG. 14.

FIGS. 15-20 illustrate a quadpolar feedthrough filter capacitor assembly 500 which utilizes a pair of ground pins 520 to conductively couple the second set of electrode plates 514 of the capacitor 510 with the ground plates 508 of the alumina insulator 506 for grounding to the ferrule 504, as described above. Terminal pins 502 (a total of four in this embodiment) are conductively coupled to the first set of electrode plates 512, but pass through the ferrule 504 and the alumina insulator 506 in non-conductive relation, as described above. Conductive coupling of the pins 502 and 520 with the first and second electrode plates 512 and 514 are illustrated in FIGS. 17-18. Similarly, conductive coupling and non-conductive coupling of the pins 502 and 520 with the ground plates 508 are illustrated in FIGS. 19 and 20.

The significant advantage of the novel internally grounded feedthrough capacitor assemblies, as described herein, is that the mechanical (and electrical) connection to the outer surface of the capacitor is eliminated. In addition to eliminating manufacturing operations and reducing costs, this has the added effect of greatly reducing the mechanical stresses coupled to the relatively brittle ceramic capacitor structure caused by the mismatch in the thermal coefficient of expansion of the ceramic capacitor and the terminal or substrate to which it is mounted. This is particularly important for medical implant devices where the combined filter capacitor and hermetic terminal see high terminal stresses due to the requirement to weld such structure to the housing of a medical implant device. Thus, the capacitor structure is allowed to "float" in relative isolation from the surrounding materials. By elimination of the mechanical and electrical connection to the outside perimeter or outside diameter, the possibility of an adjunct or false hermetic seal is reduced or eliminated. Another benefit is that the penetration of the internal electrode plates to the external perimeter or outside diameter of the capacitor has been eliminated. This results in a more physically robust capacitor design with less tendency to delaminate along the knit line for internal electrode lamination layer. Accordingly, there would be less tendency for the capacitor to fracture, delaminate or otherwise structurally fail under thermal, mechanical or piezoelectric stresses. The only point of capacitor electrode penetration is the inside diameter of the cylindrical passageways for terminal pin connection. This tends to make the feedthrough capacitor a more solid, monolithic structure which is more resistant to moisture or solvent penetration. As the brittle ceramic capacitor is isolated from the ferrule, the capacitor is much more resistant to damage during ferrule installation by soldering, pressing, or screw-in torque. The capacitor, being isolated from the case or ferrule, makes it much more resistant to gripping tools which are used by the customer during installation.

As previously mentioned, internally grounded feedthrough capacitors are known in the art and described by U.S. Pat. Nos. 5,905,627 and 6,529,103. These two patents describe internally grounded capacitors with various means for connecting the capacitor's second set (or ground electrode set) of electrodes to a terminal pin which is part of the ferrule. The significant advantage of the novel internally grounded hermetic insulator is that this eliminates the need for one or more conductive terminal pins to be brazed or

12

welded into the ferrule itself. This is particularly important for cylindrical EMI filter hermetic terminal assemblies. The reason for this is it is quite difficult to extend a web plate across the ferrule to the center of the capacitor. It is far better to have an insulative structure between the capacitor or inductor and the alumina insulator structure 106. The present invention eliminates the need for a web plate and welded terminal pin which is, effectively, all part of the ferrule. The present invention also provides a high degree of volumetric efficiency in that by elimination of the web plate there is no need to increase the overall height of the EMI filter terminal assembly. Referring once again to FIG. 2, one can see that the addition of the internal ground electrode plates 108 into the hermetic insulator 106 does not substantially increase the overall height of the hermetic insulator at all. Accordingly, it is a primary feature of the present invention to provide a grounding pin or conductive material 120 for grounding the capacitor second electrode plate set in such a way that the overall volume of the assembly is not increased at all.

Although several embodiments of the invention have been described in detail for purposes of illustration, various modifications of each may be made without departing from the spirit and scope of the invention. Accordingly, the invention is not to be limited, except as by the appended claims.

What is claimed is:

- [1. A feedthrough filter capacitor assembly, comprising: a conductive terminal pin; a feedthrough filter capacitor having first and second sets of electrode plates, a first passageway through which the terminal pin extends in conductive relation with the first set of electrode plates; a conductive ferrule through which the terminal pin extends in non-conductive relation; an insulator having a first passageway through which the terminal pin extends in non-conductive relation, and a ground plate conductively coupled to the ferrule; and means for conductively coupling the capacitor second set of electrode plates and the insulator ground plate.]
- [2. The assembly of claim 1, wherein the insulator ground plate comprises a set of ground plates.]
- [3. The assembly of claim 2, wherein the coupling means includes a conductive material pin at least partially extending through a second passageway of the capacitor in conductive relation with the second set of electrode plates, and at least partially extending through a second passageway of the insulator in conductive relation with the set of ground plates.]
- [4. The assembly of claim 3, wherein the conductive material comprises a ground pin, a ground wire, a solder material, a conductive thermal setting material, a weld, a braze, a conductive glass, or a conductive spring coil.]
- [5. The assembly of claim 1, wherein the ferrule is conductively coupled to a housing for an active implantable medical device.]
- [6. The assembly of claim 5, wherein the active implantable medical device is a cardiac pacemaker, an implantable defibrillator, a congestive heart failure device, a hearing implant, a cochlear implant, a neurostimulator, a drug pump, a ventricular assist device, an insulin pump, a spinal cord stimulator, an implantable sensing system, a deep brain stimulator, an artificial heart, an incontinence device, a vagus nerve stimulator, a bone growth stimulator, a gastric pacemaker, or a prosthetic device.]
- [7. The assembly of claim 1, including an inductor through which the terminal pin extends in non-conductive relation.]

## 13

[8. The assembly of claim 7, wherein the inductor comprises a ferrite inductor slab.]

[9. The assembly of claim 7, wherein the inductor is disposed adjacent to the capacitor.]

[10. The assembly of claim [9] 49, wherein the inductor is disposed between the capacitor and the *hermetic* insulator.

[11. The assembly of claim 1, wherein an outer peripheral surface of the capacitor is non-conductive.]

[12. The assembly of claim 1, wherein the insulator comprises an alumina insulator.]

[13. The assembly of claim 1, wherein the insulator ground plate extends to a conductive outer peripheral surface of the insulator.]

[14. The assembly of claim 13, wherein the conductive outer peripheral surface of the insulator is conductively coupled to the ferrule.]

[15. The assembly of claim 1, wherein the capacitor and insulator are disposed adjacent to each other and separated by a non-conductive material.]

[16. A feedthrough filter capacitor assembly, comprising:

a conductive terminal pin;

a feedthrough filter capacitor having first and second sets of electrode plates, a first passageway through which the terminal pin extends in conductive relation with the first set of electrode plates;

a conductive ferrule through which the terminal pin extends in non-conductive relation;

an insulator having a first passageway through which the terminal pin extends in non-conductive relation, and a ground plate conductively coupled to the ferrule; and a conductive material at least partially extending through a second passageway of the capacitor in conductive relation with the second set of electrode plates and at least partially extending through a second passageway of the insulator in conductive relation with the ground plate, for conductively coupling the capacitor second set of electrode plates and the ground plate.]

[17. The assembly of claim 16, wherein the conductive material comprises a ground pin, a ground wire, a solder material, a conductive thermal setting material, a weld, a braze, a conductive glass, or a conductive spring coil.]

[18. The assembly of claim 16, wherein the ferrule is conductively coupled to a housing for an active implantable medical device.]

[19. The assembly of claim 18, wherein the active implantable medical device is a cardiac pacemaker, an implantable defibrillator, a congestive heart failure device, a hearing implant, a cochlear implant, a neurostimulator, a drug pump, a ventricular assist device, an insulin pump, a spinal cord stimulator, an implantable sensing system, a deep brain stimulator, an artificial heart, an incontinence device, a vagus nerve stimulator, a bone growth stimulator, a gastric pacemaker, or a prosthetic device.]

[20. The assembly of claim 16, including an inductor through which the terminal pin extends in non-conductive relation.]

[21. The assembly of claim 20, wherein the inductor comprises a ferrite inductor slab.]

[22. The assembly of claim 20, wherein the inductor is disposed adjacent to the capacitor.]

[23. The assembly of claim [22] 61, wherein the inductor is disposed between the capacitor and the *hermetic* insulator.

[24. The assembly of claim 16, wherein an outer peripheral surface of the capacitor is non-conductive.]

[25. The assembly of claim 16, wherein the insulator comprises an alumina insulator.]

## 14

[26. The assembly of claim 16, wherein the insulator ground plate extends to a conductive outer peripheral surface of the insulator which is conductively coupled to the ferrule.]

[27. The assembly of claim 16, wherein the capacitor and insulator are disposed adjacent to each other and separated by a non-conductive material.]

[28. The assembly of claim 16, wherein the insulator ground plate comprises a set of ground plates.]

[29. A feedthrough filter capacitor assembly, comprising:

a conductive terminal pin;

a feedthrough filter capacitor having first and second sets of electrode plates, and a first passageway through which the terminal pin extends in conductive relation with the first set of electrode plates;

a conductive ferrule conductively coupled to a housing for an active implantable medical device and through which the terminal pin extends in non-conductive relation;

an insulator having a first passageway through which the terminal pin extends in non-conductive relation, and a ground plate extending to a conductive outer peripheral surface of the insulator that is conductively coupled to the ferrule; and

a conductive material at least partially extending through a second passageway of the capacitor in conductive relation with the second set of electrode plates, and at least partially extending through a second passageway of the insulator in conductive relation with the ground plate for conductively coupling the second set of electrode plates and the ferrule.]

[30. The assembly of claim 29, wherein the conductive material comprises a ground pin, a ground wire, a solder material, a conductive thermal setting material, a weld, a braze, a conductive glass, or a conductive spring coil.]

[31. The assembly of claim 29, wherein the active implantable medical device is a cardiac pacemaker, an implantable defibrillator, a congestive heart failure device, a hearing implant, a neurostimulator, a drug pump, a ventricular assist device, an insulin pump, a spinal cord stimulator, an implantable sensing system, a deep brain stimulator, an artificial heart, an incontinence device, a vagus nerve stimulator, a bone growth stimulator, a gastric pacemaker, or a prosthetic device.]

[32. The assembly of claim 29, including an inductor through which the terminal pin extends in non-conductive relation.]

[33. The assembly of claim 32, wherein the inductor comprises a ferrite inductor slab.]

[34. The assembly of claim 32, wherein the inductor is disposed adjacent to the capacitor.]

[35. The assembly of claim [34] 74, wherein the inductor is disposed between the capacitor and the *hermetic* insulator.

[36. The assembly of claim 29, wherein an outer peripheral surface of the capacitor is non-conductive.]

[37. The assembly of claim 29, wherein the insulator comprises an alumina insulator.]

[38. The assembly of claim 29, wherein the capacitor and insulator are disposed adjacent to each other and separated by a non-conductive material.]

39. A feedthrough filter capacitor assembly, comprising:

a) at least two conductive terminal pins;

b) an internally grounded feedthrough filter capacitor having interleaved active and ground electrode plates, at least two capacitor first passageways through which respective ones of the terminal pins extend in conductive relation with the capacitor active electrode plates;

- c) a conductive ferrule through which the at least two terminal pins extend in non-conductive relation;
- d) a hermetic insulator connected to the ferrule, the hermetic insulator having at least two insulator first passageways through which respective ones of the at least two terminal pins extend in non-conductive relation with the ferrule, and
- e) at least one insulator ground plate embedded in the hermetic insulator, the embedded insulator ground plate being electrically connected to the ferrule, wherein the embedded insulator ground plate surrounds but is spaced from each of the at least two insulator first passageways through which respective ones of the terminal pins extend in conductive relation with the capacitor active electrode plates extend; and
- f) means for electrically connecting the capacitor ground electrode plates and the at least one embedded insulator ground plate.

40. The assembly of claim 39, wherein the means for electrically connecting resides between the at least two terminal pins.

41. The assembly of claim 39, wherein the capacitor ground electrode plates do not extend to an outer perimeter of the feedthrough filter capacitor.

42. The assembly of claim 39, wherein the at least one embedded insulator ground plate comprises a set of embedded insulator ground plates.

43. The assembly of claim 39, wherein the means for electrically connecting includes a conductive material pin at least partially extending through a second passageway of the capacitor in conductive relation with the capacitor ground electrode plates, and at least partially extending through a second passageway of the hermetic insulator in conductive relation with the at least one embedded insulator ground plate.

44. The assembly of claim 43, wherein the conductive material pin comprises a ground pin, a ground wire, a solder material, a conductive thermal setting material, a weld, a braze, a conductive glass, or a conductive spring coil.

45. The assembly of claim 39, wherein the ferrule is electrically connected to a housing for an active implantable medical device.

46. The assembly of claim 45, wherein the active implantable medical device is a cardiac pacemaker, an implantable defibrillator, a congestive heart failure device, a hearing implant, a cochlear implant, a neurostimulator, a drug pump, a ventricular assist device, an insulin pump, a spinal cord stimulator, an implantable sensing system, a deep brain stimulator, an artificial heart, an incontinence device, a Vagus nerve stimulator, a bone growth stimulator, a gastric pacemaker, or a prosthetic device.

47. The assembly of claim 39, including an inductor through which the at least two terminal pins extend in non-conductive relation.

48. The assembly of claim 47, wherein the inductor comprises a ferrite inductor slab.

49. The assembly of claim 47, wherein the inductor is disposed adjacent to the capacitor.

50. The assembly of claim 39, wherein the capacitor has an outer periphery surface, and wherein the outer peripheral surface of the capacitor is non-conductive.

51. The assembly of claim 39, wherein the hermetic insulator comprises an alumina insulator.

52. The assembly of claim 39, wherein the at least one embedded insulator ground plate extends to a conductive outer peripheral surface of the hermetic insulator.

53. The assembly of claim 52, wherein the conductive outer peripheral surface of the insulator comprises a metallization layer and a solder or braze electrically connecting the metallization layer to the ferrule.

54. The assembly of claim 39, wherein the capacitor and hermetic insulator are disposed adjacent to each other and separated by a washer of non-conductive material.

55. The assembly of claim 39, wherein there are at least two means for electrically connecting, and wherein the at least two terminal pins reside between the at least two means for electrically connecting.

56. A feedthrough filter capacitor assembly, comprising:

- a) at least two conductive terminal pins;
- b) a feedthrough filter capacitor having interleaved active and ground electrode plates, and at least two capacitor first passageways through which respective ones of the at least two terminal pins extend in conductive relation with the capacitor active electrode plates;

c) a conductive ferrule through which the at least two terminal pins extend in non-conductive relation;

d) a hermetic insulator connected to the ferrule, the hermetic insulator having at least two insulator first passageways through which respective ones of the at least two terminal pins extend in non-conductive relation with the ferrule;

e) an insulator ground plate embedded in the hermetic insulator, the embedded insulator ground plate being electrically connected to the ferrule, wherein the embedded insulator ground plate surrounds but is spaced from each of the at least two insulator first passageways through which respective ones of the terminal pins in conductive relation with the capacitor active electrode plates extend; and

f) a ground pin at least partially extending through a second passageway of the capacitor in conductive relation with the capacitor ground electrode plates and at least partially extending through a second passageway of the hermetic insulator in conductive relation with the embedded insulator ground plate, the ground pin electrically connecting the capacitor ground electrode plates and the embedded insulator ground plate.

57. The assembly of claim 55, wherein the ferrule is electrically connected to a housing for an active implantable medical device.

58. The assembly of claim 57, wherein the active implantable medical device is a cardiac pacemaker, an implantable defibrillator, a congestive heart failure device, a hearing implant, a cochlear implant, a neurostimulator, a drug pump, a ventricular assist device, an insulin pump, a spinal cord stimulator, an implantable sensing system, a deep brain stimulator, an artificial heart, an incontinence device, a Vagus nerve stimulator, a bone growth stimulator, a gastric pacemaker, or a prosthetic device.

59. The assembly of claim 55, including an inductor through which the at least two terminal pins extend in non-conductive relation.

60. The assembly of claim 59, wherein the inductor comprises a ferrite inductor slab.

61. The assembly of claim 59, wherein the inductor is disposed adjacent to the capacitor.

62. The assembly of claim 55, wherein the capacitor has an outer periphery surface, and wherein the outer peripheral surface of the capacitor is non-conductive.

63. The assembly of claim 55, wherein the hermetic insulator comprises an alumina insulator.

64. The assembly of claim 55, wherein the embedded insulator ground plate extends to a conductive outer peripheral surface of the hermetic insulator.

eral surface of the hermetic insulator, the conductive outer peripheral surface comprising a metallization layer contacting the embedded insulator ground plate at the outer peripheral surface of the hermetic insulator, and a solder or braze electrically connecting the metallization layer to the ferrule. 5

65. The assembly of claim 55, wherein the capacitor and hermetic insulator are disposed adjacent to each other and separated by washer a non-conductive material.

66. The assembly of claim 55, wherein the embedded insulator ground plate comprises a set of insulator ground plates. 10

67. The assembly of claim 55, wherein the ground pin connecting the capacitor ground electrode plates and the embedded insulator ground plate resides between the at least two terminal pins. 15

68. The assembly of claim 55, wherein the capacitor ground electrode plates do not extend to an outer perimeter of the feedthrough filter capacitor.

69. The assembly of claim 55, wherein there are at least two ground pins, and wherein the at least two terminal pins reside between the at least two ground pins. 20

70. An active implantable medical device (AIMD), comprising:

a) a housing for the AIMD; and

b) a feedthrough filter capacitor assembly, comprising: 25

i) at least two conductive terminal pins;

ii) a feedthrough filter capacitor having interleaved active and ground electrode plates, and at least two capacitor first passageways through which respective ones of the at least two terminal pins extend in conductive relation with the capacitor active electrode plates; 30

iii) a conductive ferrule electrically connected to the AIMD housing, wherein the at least two terminal pins extend through the ferrule in non-conductive relation; 35

iv) a hermetic insulator connected to the ferrule, the hermetic insulator having at least two insulator first passageways through which respective ones of the at least two terminal pins extend in non-conductive relation with the ferrule; 40

v) an insulator ground plate embedded in the insulator and extending to a conductive outer peripheral surface of the insulator, the embedded insulator ground plate being electrically connected to the ferrule, wherein the embedded insulator ground plate surrounds but is spaced from each of the at least two insulator first passageways through which respective 45

ones of the terminal pins in conductive relation with the capacitor active electrode plates extend; and vi) a ground pin at least partially extending through a second passageway of the capacitor in conductive relation with the capacitor ground electrode plates and at least partially extending through a second passageway of the hermetic insulator in conductive relation with the embedded insulator ground plate, the ground pin electrically connecting the capacitor ground electrode plates to the ferrule.

71. The AIMD of claim 70, wherein the active implantable medical device is a cardiac pacemaker, an implantable defibrillator, a congestive heart failure device, a hearing implant, a neurostimulator, a drug pump, a ventricular assist device, an insulin pump, a spinal cord stimulator, an implantable sensing system, a deep brain stimulator, an artificial heart, an incontinence device, a Vagus nerve stimulator, a bone growth stimulator, a gastric pacemaker, or a prosthetic device. 10

72. The AIMD of claim 70, including an inductor through which the at least two terminal pins extend in non-conductive relation. 15

73. The AIMD of claim 72, wherein the inductor comprises a ferrite inductor slab.

74. The AIMD of claim 72, wherein the inductor is disposed adjacent to the capacitor. 25

75. The AIMD of claim 70, wherein an outer peripheral surface of the capacitor is non-conductive.

76. The AIMD of claim 70, wherein the hermetic insulator comprises an alumina insulator. 30

77. The AIMD of claim 70, wherein the capacitor and hermetic insulator are disposed adjacent to each other and separated by a washer of non-conductive material.

78. The AIMD of claim 70, wherein the ground pin electrically connecting the capacitor ground electrode plates and the embedded insulator ground plate resides between the at least two terminal pins. 35

79. The AIMD of claim 70, wherein the capacitor ground electrode plates do not extend to an outer perimeter of the feedthrough filter capacitor. 40

80. The AIMD of claim 70, wherein the conductive outer peripheral surface of the insulator comprises a metallization layer contacting the embedded insulator ground plate at the outer peripheral surface, and wherein a solder or braze electrically connects the metallization layer to the ferrule. 45

81. The assembly of claim 70, wherein there are at least two ground pins, and wherein the at least two terminal pins reside between the at least two ground pins.

\* \* \* \* \*