



US00RE48326E

(19) **United States**
(12) **Reissued Patent**
Park et al.

(10) **Patent Number: US RE48,326 E**
(45) **Date of Reissued Patent: *Nov. 24, 2020**

(54) **METHOD OF TRANSMITTING AND RECEIVING RADIO ACCESS INFORMATION IN A WIRELESS MOBILE COMMUNICATIONS SYSTEM**

(58) **Field of Classification Search**
CPC H04L 7/00; H04L 17/06; H04W 74/02;
H04W 36/0055

(Continued)

(71) Applicant: **EVOLVED WIRELESS LLC**, Austin, TX (US)

(56) **References Cited**

(72) Inventors: **Sung Jun Park**, Anyang-si (KR); **Young Dae Lee**, Anyang-si (KR); **Sung Duck Chun**, Anyang-si (KR); **Myung Cheul Jung**, Anyang-si (KR)

U.S. PATENT DOCUMENTS

5,311,176 A 5/1994 Gurney
5,345,448 A 9/1994 Keskitalo

(Continued)

(73) Assignee: **EVOLVED WIRELESS LLC**, Austin, TX (US)

FOREIGN PATENT DOCUMENTS

(*) Notice: This patent is subject to a terminal disclaimer.

CN 1437416 A 8/2003
CN 1505912 6/2004

(Continued)

(21) Appl. No.: **15/804,824**

OTHER PUBLICATIONS

(22) Filed: **Nov. 6, 2017**

IEEE "Draft IEEE Standard for Local and Metropolitan Area Networks: Part 16: Air Interface for Fixed and Mobile Broadband Wireless Access Systems" XP-002670655; IEEE P802.16e/D12, Oct. 14, 2005; pp. 1; 194; 200-205.

(Continued)

Related U.S. Patent Documents

Reissue of:

(64) Patent No.: **8,412,201**
Issued: **Apr. 2, 2013**
Appl. No.: **13/487,081**
Filed: **Jun. 1, 2012**

U.S. Applications:

(63) Continuation of application No. 14/676,490, filed on Apr. 1, 2015, now Pat. No. Re. 46,602, which is an
(Continued)

Primary Examiner — Matthew E Heneghan

(74) *Attorney, Agent, or Firm* — Jason H. Vick; Sheridan Ross, PC

(30) **Foreign Application Priority Data**

Jul. 5, 2006 (KR) 10-2006-0063135

(57) **ABSTRACT**

In a wireless mobile communications system, a method of transmitting and receiving radio access information that allows a faster and an efficient way of establishing a radio connection between a terminal and a target base station while performing a handover for the terminal to a cell of the target base station. The network transmits in advance, the radio access information and the like, to the terminal so that the terminal can be connected with the target cell in a faster manner which minimizes the total time for the handover process.

(51) **Int. Cl.**
H04W 36/00 (2009.01)
H04L 7/00 (2006.01)
H04W 74/00 (2009.01)

(52) **U.S. Cl.**
CPC **H04W 36/0055** (2013.01); **H04L 7/00** (2013.01); **H04W 74/002** (2013.01); **H04W 74/006** (2013.01)

8 Claims, 7 Drawing Sheets

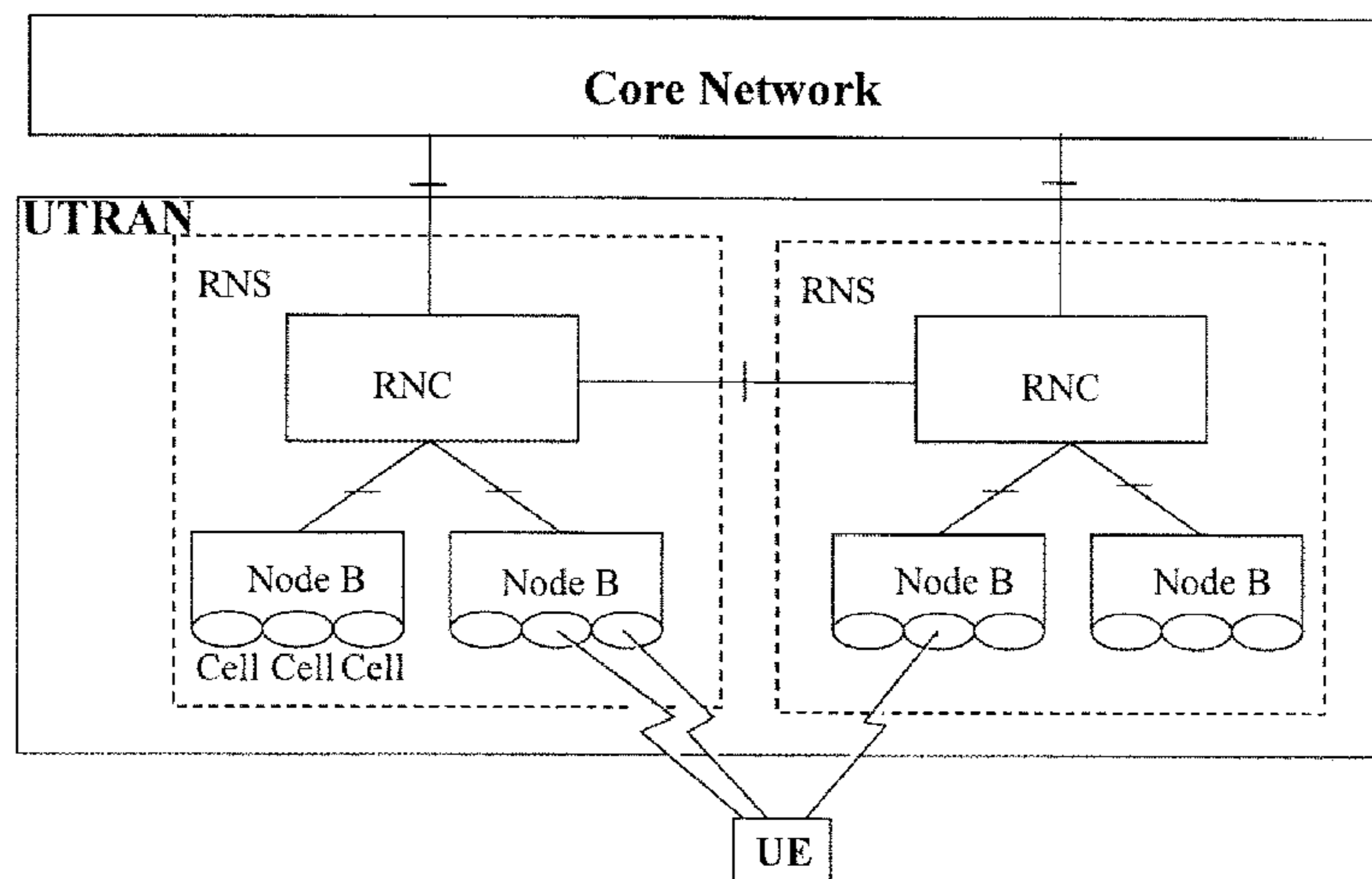

Related U.S. Application Data

application for the reissue of Pat. No. 8,412,201, which is a continuation of application No. 12/870,747, filed on Aug. 27, 2010, now Pat. No. 8,219,097, which is a continuation of application No. 11/553,939, filed on Oct. 27, 2006, now Pat. No. 7,809,373.

(60) Provisional application No. 60/732,080, filed on Oct. 31, 2005.

(58) **Field of Classification Search**
USPC 370/331; 455/436
See application file for complete search history.

(56) **References Cited**

U.S. PATENT DOCUMENTS

5,553,153 A 9/1996 Eatwell
5,677,908 A 10/1997 Oura
5,697,055 A 12/1997 Gilhousen et al.
5,722,072 A 2/1998 Crichton et al.
6,161,014 A 12/2000 Girardeau et al.
6,161,160 A 12/2000 Niu et al.
6,359,876 B1 3/2002 Kamata
6,374,080 B2 4/2002 Uchida
6,532,225 B1 3/2003 Chang et al.
6,563,807 B1* 5/2003 Kim et al. 370/331
6,628,632 B1 9/2003 Dolan
6,628,946 B1 9/2003 Wiberg et al.
6,778,509 B1 8/2004 Ravishankar et al.
6,845,238 B1 1/2005 Muller
6,920,155 B2 7/2005 Rao
6,944,453 B2 9/2005 Faerber et al.
6,968,192 B2 11/2005 Longoni
7,047,009 B2 5/2006 Laroia et al.
7,068,625 B1 6/2006 Schindler et al.
7,106,814 B2 9/2006 Carsello
7,200,788 B2 4/2007 Hiraki et al.
7,292,641 B2 11/2007 Suh et al.
7,321,645 B2 1/2008 Lee et al.
7,400,573 B2 7/2008 Sundstrom et al.
7,417,970 B2 8/2008 Shaheen
7,424,067 B2 9/2008 Vanderperren et al.
7,426,175 B2 9/2008 Zhuang et al.
7,433,418 B1 10/2008 Dogan et al.
7,447,504 B2 11/2008 Lohr et al.
7,471,948 B2 12/2008 Farnsworth et al.
7,496,113 B2 2/2009 Cai et al.
7,508,792 B2 3/2009 Petrovic et al.
7,570,618 B2 8/2009 Son et al.
7,580,400 B2 8/2009 Sung et al.
7,590,183 B2 9/2009 Yonge, III et al.
7,593,732 B2 9/2009 Kim et al.
7,599,327 B2 10/2009 Zhuang
7,623,439 B2 11/2009 Webster et al.
7,664,076 B2 2/2010 Kim et al.
7,675,841 B2 3/2010 Suh et al.
7,693,517 B2 4/2010 Etemad et al.
7,693,924 B2 4/2010 Cho et al.
7,701,919 B2 4/2010 Ah Lee
7,702,028 B2 4/2010 Zhou et al.
7,809,373 B2* 10/2010 Park H04W 74/006
370/338
7,961,696 B2 6/2011 Ma et al.
7,983,676 B2* 7/2011 Ju et al. 455/439
7,995,967 B2 8/2011 Li et al.
8,000,305 B2 8/2011 Tan et al.
8,098,745 B2 1/2012 Bertrand et al.
8,116,195 B2 2/2012 Hou et al.
8,121,045 B2 2/2012 Cai et al.
8,131,295 B2 3/2012 Wang et al.
8,180,058 B2 5/2012 Kitazoe
8,199,730 B2 6/2012 Ou et al.
8,219,097 B2 7/2012 Park et al.
8,340,232 B2 12/2012 Ding et al.
8,412,201 B2 4/2013 Park et al.

8,448,037 B2 5/2013 Bergquist et al.
8,977,258 B2 3/2015 Chou
9,094,202 B2 7/2015 Maheshwari et al.
9,204,468 B2 12/2015 Tynderfeldt et al.
RE46,602 E* 11/2017 Park H04L 7/00
RE46,679 E 1/2018 Park et al.
RE46,714 E* 2/2018 Park
2001/0016496 A1 8/2001 Lee
2001/0026543 A1 10/2001 Hwang et al.
2001/0036113 A1 11/2001 Jurgensen et al.
2002/0041578 A1 4/2002 Kim et al.
2002/0045448 A1 4/2002 Park et al.
2002/0048266 A1* 4/2002 Choi et al. 370/331
2002/0051431 A1 5/2002 Choi et al.
2002/0071480 A1 6/2002 Marjelund et al.
2002/0085516 A1 7/2002 Bridgelall
2002/0089957 A1 7/2002 Vero
2002/0122393 A1 9/2002 Caldwell et al.
2002/0159412 A1* 10/2002 Odenwalder et al. 370/335
2002/0181436 A1 12/2002 Mueckenheim et al.
2003/0002472 A1 1/2003 Choi et al.
2003/0008653 A1 1/2003 Jiang
2003/0026324 A1* 2/2003 Li et al. 375/141
2003/0048763 A1 3/2003 Kondo
2003/0054829 A1 3/2003 Moasio
2003/0076812 A1 4/2003 Benedittis et al.
2003/0091108 A1 5/2003 Tanaka
2003/0131300 A1 7/2003 Park et al.
2003/0207696 A1 11/2003 Willenegger et al.
2004/0009767 A1 1/2004 Lee et al.
2004/0022217 A1 2/2004 Korpela et al.
2004/0029532 A1 2/2004 Schwarz et al.
2004/0047284 A1 3/2004 Eidson
2004/0053614 A1 3/2004 Il-Gyu et al.
2004/0085926 A1 5/2004 Hwang et al.
2004/0103435 A1 5/2004 Yi et al.
2004/0114574 A1 6/2004 Zeira et al.
2004/0127244 A1 7/2004 Matsumoto et al.
2004/0152473 A1 8/2004 Kuwano et al.
2004/0152478 A1 8/2004 Ruohonen et al.
2004/0162072 A1 8/2004 Sigle et al.
2004/0171401 A1 9/2004 Balachandran et al.
2004/0185852 A1 9/2004 Son et al.
2005/0041573 A1 2/2005 Eom et al.
2005/0059437 A1 3/2005 Son et al.
2005/0073988 A1 4/2005 Kroth et al.
2005/0075108 A1* 4/2005 Cho H04W 36/0055
455/436
2005/0084030 A1 4/2005 Zhou et al.
2005/0105488 A1 5/2005 Raji et al.
2005/0105505 A1 5/2005 Fishler et al.
2005/0107105 A1 5/2005 Wakabayashi
2005/0119004 A1 6/2005 Gao et al.
2005/0122950 A1 6/2005 Ikeda et al.
2005/0138528 A1 6/2005 Ameigeiras et al.
2005/0143072 A1 6/2005 Yoon et al.
2005/0177623 A1 8/2005 Roberts et al.
2005/0181801 A1 8/2005 Funnell
2005/0197132 A1 9/2005 Lee et al.
2005/0213543 A1 9/2005 Shimizu et al.
2005/0213689 A1 9/2005 Matsuda et al.
2005/0227691 A1 10/2005 Pecen et al.
2005/0259567 A1 11/2005 Webster et al.
2005/0271025 A1 12/2005 Guethaus et al.
2005/0272426 A1 12/2005 Yang et al.
2005/0282547 A1 12/2005 Kim et al.
2006/0018336 A1 1/2006 Sutivong et al.
2006/0039327 A1 2/2006 Samuel et al.
2006/0056355 A1 3/2006 Love et al.
2006/0114812 A1 6/2006 Kim et al.
2006/0126570 A1 6/2006 Kim et al.
2006/0274843 A1 12/2006 Koo et al.
2007/0010268 A1 1/2007 Kim et al.
2007/0032255 A1 2/2007 Koo et al.
2007/0058595 A1 3/2007 Classon et al.
2007/0110172 A1 5/2007 Faulkner et al.
2007/0117563 A1 5/2007 Terry et al.
2007/0133458 A1 6/2007 Chandra et al.
2007/0147315 A1 6/2007 Houry et al.

(56)

References Cited

U.S. PATENT DOCUMENTS

2007/0155388 A1* 7/2007 Petrovic et al. 455/442
 2007/0253465 A1 11/2007 Muharemovic et al.
 2007/0270273 A1 11/2007 Fukuta et al.
 2007/0291696 A1 12/2007 Zhang et al.
 2007/0291708 A1 12/2007 Rao
 2008/0062905 A1 3/2008 Goldberg et al.
 2008/0095119 A1 4/2008 Bachmann et al.
 2008/0123585 A1 5/2008 Gransow et al.
 2008/0254800 A1 10/2008 Chun et al.
 2008/0287138 A1 11/2008 Yoon et al.
 2009/0163211 A1 6/2009 Kitazoe et al.
 2009/0207810 A1 8/2009 Petrovic et al.

FOREIGN PATENT DOCUMENTS

CN 1596020 A 3/2005
 EP 1134992 9/2001
 EP 1326460 A1 7/2003
 EP 1388964 2/2004
 EP 1404079 3/2004
 EP 1469697 A2 10/2004
 EP 1519519 A1 3/2005
 EP 1097602 4/2007
 EP 1968256 9/2008
 EP 1794971 B1 3/2010
 EP 1787414 B1 1/2012
 GB 2332340 6/1999
 JP 09-186704 7/1997
 JP 10-136426 5/1998
 JP 11-146462 5/1999
 JP 11-196477 7/1999
 JP 11-341541 12/1999
 JP 2000-069531 3/2000
 JP 2001-078246 3/2001
 JP 2001-313968 11/2001
 JP 2003-500950 1/2003
 JP 2003-087842 3/2003
 JP 2003-102055 4/2003
 JP 2003-152600 5/2003
 JP 2003-324761 11/2003
 JP 2004-135287 4/2004
 JP 2004-208177 7/2004
 JP 2004-221760 8/2004
 JP 2004-289234 10/2004
 JP 2005-509313 4/2005
 JP 2005-124215 5/2005
 JP 2005-513907 5/2005
 JP 2005-525065 8/2005
 JP 2005-237031 9/2005
 JP 2005-260337 9/2005
 JP 2005-277570 10/2005
 JP 2006-507753 3/2006
 KR 10-2003-0007481 1/2003
 KR 10-2003-0056143 7/2003
 KR 10-2005-0032285 4/2005
 KR 10-2005-0078635 8/2005
 KR 10-2005-0078636 8/2005
 KR 10-2005-0084908 8/2005
 KR 10-2006-0066595 6/2006
 KR 10-062668 9/2006
 KR 10-0688303 3/2007
 KR 10-2007-0055845 5/2007
 KR 10-2008-0004025 1/2008
 RU 2145774 2/2000
 RU 2149518 5/2000
 RU 2193281 11/2002
 RU 2216100 11/2003
 WO WO 94/08432 4/1994
 WO WO 99/59253 11/1999
 WO WO 00/72609 11/2000
 WO WO 00/74420 12/2000
 WO WO 01/41471 6/2001
 WO WO 01/76110 10/2001
 WO WO 02/09825 2/2002
 WO WO 02/080401 10/2002

WO WO 02/082666 10/2002
 WO WO 03/017544 2/2003
 WO WO 03/055105 7/2003
 WO WO 03/088691 10/2003
 WO WO 03/096149 11/2003
 WO WO 03/096731 11/2003
 WO WO 03/103320 12/2003
 WO WO 2004/016016 2/2004
 WO WO 2004/017541 2/2004
 WO WO 2004/030392 4/2004
 WO WO 2004/042954 5/2004
 WO WO 2005/011134 2/2005
 WO WO 2005/018255 2/2005
 WO WO 2005/043791 5/2005
 WO WO 2005/060132 6/2005
 WO WO 2005/072073 8/2005
 WO WO 2005/078966 8/2005
 WO WO 2005/083912 9/2005
 WO WO 2005/088882 9/2005
 WO WO 2005/089002 9/2005
 WO WO 2006/023536 3/2006
 WO WO 2007/082409 7/2007
 WO WO 2007/138453 12/2007

OTHER PUBLICATIONS

European Search Report for European Application No. 19164548.0, dated Jul. 18, 2019.
 Documents filed with U.S. District Court Proceedings for *Evolved Wireless, LLC v. Apple Inc.*; U.S. District Court, for the District of Delaware (Wilmington); Civil Action No. 1:15-cv-00542-SLR-SRF; Includes documents filed from Jun. 13, 2019-Aug. 9, 2019; Docket Nos. 538-545; (105 pages).
 Documents filed with U.S. District Court Proceedings for *Evolved Wireless, LLC v. HTC Corporation et al.*; U.S. District Court, for the District of Delaware (Wilmington); Civil Action No. 1:15-cv-00543-SLR-SRF; Includes documents filed from Jun. 13, 2019-Aug. 14, 2019; Docket Nos. 430-431; (10 pages).
 Documents filed with U.S. District Court Proceedings for *Evolved Wireless, LLC v. Motorola Mobility, et al.*; U.S. District Court, for the District of Delaware (Wilmington); Civil Action No. 1:15-cv-00544-SLR-SRF; Includes documents filed on Jun. 13, 2019; Docket No. 393; (7 pages).
 Documents filed with U.S. District Court Proceedings for *Evolved Wireless, LLC v. Samsung Electronics Co. Ltd., et al.*; U.S. District Court, for the District of Delaware (Wilmington); Civil Action No. 1:15-cv-00545-SLR-SRF; Includes documents filed on Jun. 13, 2019; Docket No. 476; (7 pages).
 Documents filed with U.S. District Court Proceedings for *Evolved Wireless, LLC v. ZTE Corporation*; U.S. District Court, for the District of Delaware (Wilmington); Civil Action No. 1:15-cv-00546-SLR-SRF; Includes documents filed on Jun. 13, 2019; Docket No. 396; (7 pages).
 Documents filed with U.S. District Court Proceedings for *Evolved Wireless, LLC v. Microsoft Corporation, et al.*; U.S. District Court, for the District of Delaware (Wilmington); Civil Action No. 1:15-cv-00547-SLR-SRF; Includes documents filed on Jun. 13, 2019; Docket No. 414; (7 pages).
 U.S. Appl. No. 15/824,609, filed Nov. 28, 2017, Park et al.
 U.S. Appl. No. 60/599,916, filed Aug. 10, 2004, Olfat et al.
 U.S. Appl. No. 60/666,494, filed Mar. 30, 2005, Classon et al.
 U.S. Appl. No. 60/732,080, filed Oct. 31, 2005, Lee et al.
 U.S. Appl. No. 60/759,697, filed Jan. 17, 2006, Tan et al.
 U.S. Appl. No. 60/815,246, filed Jun. 19, 2006, Zhang et al.
 U.S. Appl. No. 60/815,023, filed Jun. 20, 2006, Chandra et al.
 U.S. Appl. No. 61/015,159, filed Dec. 19, 2007, Kitazoe et al.
 U.S. Appl. No. 61/087,307, filed Aug. 8, 2008, Meylan et al.
 U.S. Appl. No. 61/087,988, filed Aug. 11, 2008, Yi et al.
 U.S. Appl. No. 61/088,257, filed Aug. 12, 2008, Meylan et al.
 3rd Generation Partnership Project "Technical Specification Group Radio Access Network; Evolved Universal Terrestrial Radio Access (E-UTRA) and Evolved Universal Terrestrial Radio Access Network (E-UTRAN); Radio Interface Protocol Aspects (Release 7)" 3GPP TR 25.813; V7.0.0 (Jun. 2006).

(56)

References Cited

OTHER PUBLICATIONS

3GPP Meeting Registration; Meeting: RAN2#62; Kansas City; May 5, 2008 (6 pages).

3GPP Meeting Registration; Meeting: 3GPPRAN1#44; Mar. 10, 2016 (7 pages).

3GPP Meeting Registration; Meeting: 3GPPRAN1#44-bis; Mar. 12, 2016 (6 pages).

3GPP Meeting Registration; Meeting: 3GPPRAN2#62-bis; Mar. 12, 2016 (6 pages).

3GPP RAN 1 Meeting #44-bis "On the Performances of LTE RACH" Athens, Greece; Mar. 27-31, 2006; R1-060908; 6 pages.

3GPP TSG-RAN Working Group 2 Meeting #52 "Intra-RAT Handover Access Procedure" Shanghai, China; May 8-12, 2006; R2-061229 (4 pages).

3GPP TSG RAN WG1 Ad Hoc on LTE "On Allocation of Uplink Pilot Sub-Channels in EUTRA SC-FDMA" London, UK; R1-050822; Aug. 29-Sep. 2, 2005; (7 pages).

3GPP TSG RAN WG1 Ad Hoc on LTE "On Uplink Pilot in EUTRA SC-FDMA" San Diego, USA; R1-051062; Oct. 10-14, 2005 (7 pages).

3GPP TSG-RAN WG2 "Access Procedure" Shanghai, China; R2-061201; May 8-12, 2006 (3 pages).

3GPP TSG RAN WG1 #42 on LTE "Orthogonal Pilot Channel in the Same Node B in Evolved UTRA Uplink" London, UK; R1-050851; Aug. 29-Sep. 2, 2005; (9 pages).

3GPP TSG RAN WG1 #44-bis "A New Preamble Shape for the Random Access Preamble in E-UTRA" Athens, Greece, Mar. 27-31, 2006; R1-060867; 5 pages.

3GPP TSG-RAN WG1 Meeting #44bis "Investigations on Random Access Channel Structure for E-UTRA Uplink" Athens, Greece; Mar. 27-31, 2006; R1-060992; 7 pages.

3GPP TSG-RAN WG3 #54 "Updates of Intra-LTE Handover in 36.300" Riga, Latvia Nov. 6-10, 2006; R3-061788; 6 pages.

3GPP TSG-RAN WG3 #54 "Updates of Intra-LTE Handover in 36.300" Riga, Latvia Nov. 6-10, 2006; R3-061945; 10 pages.

3GPP TSG RAN1 #44 "RACH Design for EUTRA" Denver, USA; R1-060387; Feb. 13-17, 2006 (11 pages).

3GPP TSG RAN1 #44 "RACH Design for EUTRA" Denver, USA; R1-060387; Marked-Up; Feb. 13-17, 2006 (11 pages).

3GPP TSG RAN WG1 #44 "Some Consideration for LTE RACH 13.2.3.1" Denver, USA; R1-060531; Feb. 13-17, 2006 (4 pages).

3GPP TSG WG1 Meeting #44bis "RACH Design for E-UTRA" R1-060797; Athens, Greece, Mar. 27-31, 2006 (9 pages).

3GPP TSG RAN1 #44-bis "Random Access Sequence Design" R1-060884; Athens, Greece, Mar. 24-26, 2006 (7 pages).

3GPP TSG RAN1 43 "RACH Design for EUTRA" Helsinki, Finland; Jan. 23-25, 2006; R1-060025; 11 pages.

3GPP TSG-RAN WG3 #48 bis meeting "On Intra-Access Mobility for LTE_ACTIVE UEs" Cannes, France; R3-051108; Oct. 11-14, 2005 (4 pages).

3GPP TSG-RAN WG2 #50 "Intra-System Mobility" Sophia-Antipolis, France; R2-060013; Jan. 9-13, 2006 (7 pages).

3GPP TSG RAN WG2 #52 "Mobility in LTE Active" Athens, Greece; Tdoc R2-060915; Mar. 27-31, 2006 (4 pages).

3GPP TSG-RAN WG2 Meeting #53 "Cell Switching in LTE_Active State" Shanghai, China; R2-061196; May 8-12, 2006 (5 pages).

3GPP TSG-RAN WG2 #63 "NDI and Message 3" Jeju Island, Korea; Aug. 18-22, 2008; R2-084156; 5 pages.

3GPP TSG-RAN WG2 #63 "Handling of Received UL Grant in RA Procedure" Jeju, South Korea; Aug. 18-22, 2008; R2-084387; 3 pages.

3GPP TSG-RAN WG1 Meeting #53 "UL Grant for Random Access Message 3" R1-082078; Kansas City, USA; May 5-9, 2008 (4 pages).

3GPP TSG-RAN WG2 Meeting #53 "Intra-LTE Handover Operation" Shanghai, PRC; R2-061135; May 8-13, 2006 (3 pages).

3GPP TSG-RAN WG3 #53bis "Intra-LTE Mobility Procedure" Seoul, Korea; R3-061489; Oct. 10-13, 2006 (4 pages).

3GPP TSG RAN WG2 #57 "Uplink Synchronization" R2-070781; St. Louis, USA; Feb. 12-16, 2007 (3 pages).

3GPP TSG-RAN WG2 #61 bis "Control of HARQ for RACH message 3" R2-081764; Shenzhen, China; Mar. 31-Apr. 4, 2008 (5 pages).

3GPP TSG-RAN WG2 #62 "Update of MAC Random Access Procedure" Tdoc R2-082731; Kansas City, USA; May 5-9, 2008 (7 pages).

3GPP TSG-RAN2 Meeting #59bis "E-UTRA RRC TP Capturing Current Status on Mobility" Shanghai, P.R. China; Oct. 8-12, 2007; R2-074014 (11 pages).

3GPP TSG RAN2 Meeting #63 "Handling of Received UL Grant in RA Procedure" Jeju, South Korea; Aug. 18-22, 2008; Marked-Up; R2-084388; 4 pages.

3GPP TSG-RAN2 Meeting #62bis "Clarification of DL- and UL-SCH Data Transfer" Warsaw, Poland, R2-083400; Marked-Up; Jun. 30-Jul. 4, 2008 (7 pages).

3GPP TSG-RAN2 Meeting #62bis "Clarification of DL- and UL-SCH Data Transfer" Warsaw, Poland, R2-083701 (revision of R2-083400); Marked-Up; Jun. 30-Jul. 4, 2008 (8 pages).

3GPP TSG-RAN2 Meeting #62bis "NDI and Msg3" Warsaw; Poland; R2-083703; Marked-Up; Jun. 30-Jul. 4, 2008 (3 pages).

3GPP TSG-RAN2 Meeting #63 "Corrections Relating to RACH Partitioning" Jeju, Korea; R2-084788; Aug. 18-22, 2008; (4 pages).

3GPP TSG-RAN WG2 #63 "PCCH Configuration in SIB1" Jeju, Korea; R2-083882; Aug. 18-22, 2008; (4 pages).

3GPP TSG-RAN WG2 Meeting #64bis "Clarification on RA Preambles" Athens, Greece; R2-091523; Jan. 9-13, 2009 (3 pages).

3GPP TSG-RAN WG2 Meeting #64bis "Clarification on RA Preambles" Athens, Greece; R-2091523; Marked-Up; Jan. 9-13, 2009 (3 pages).

3GPP TS 25.201 V3.0.0 (Oct. 1999) "3rd Generation Partnership Project; Technical Specification Group Radio Access Network; Physical Layer—General Description (3G TS 25.201 Version 3.0.0)" Oct. 1999; 13 pages.

3GPP TS 25.211 V6.6.0 (Sep. 2005) "3rd Generation Partnership Project; Technical Specification Group Radio Access Network; Physical Channels and Mapping of Transport Channels onto Physical Channels (FDD) (Release 6)" Sep. 2005; 50 pages.

3GPP TS 25.211 V6.7.0 (Dec. 2005) "3rd Generation Partnership Project; Technical Specification Group Radio Access Network; Physical Channels and Mapping of Transport Channels onto Physical Channels (FDD) (Release 6)" Dec. 2005; 50 pages.

3GPP TS 25.213 V6.4.0 (Sep. 2005) "3rd Generation Partnership Project; Technical Specification Group Radio Access Network; Spreading and Modulation (FDD) (Release 6)" Sep. 2005; 32 pages.

3GPP TS 25.214 V5.11.0 (Jun. 2005); Release 5; Jun. 2005 (50 pages).

3GPP TS 25.302 V6.5.0 "3rd Generation Partnership Project; Technical Specification Group Radio Access Network; Services Provided by the Physical Layer (Release 6)" Sep. 2005 (75 pages).

3GPP TR 21.900 V8.2.0 (Mar. 2008) "3rd Generation Partnership Project; Technical Specification Group Services and System Aspects; Technical Specification Group Working Methods (Release 8)" Mar. 2008; 34 pages.

3GPP TR 25.813 V0.0.2 "3rd Generation Partnership Project; Technical Specification Group Radio Access Network; Evolved Universal Terrestrial Radio Access (UTRA) and Universal Terrestrial Radio Access Network (UTRAN); Radio Interface Protocol Aspects (Release 7)" Oct. 2005 (17 pages).

3GPP TR 25.813 V0.0.2 "3rd Generation Partnership Project; Technical Specification Group Radio Access Network; Evolved Universal Terrestrial Radio Access (UTRA) and Universal Terrestrial Radio Access Network (UTRAN); Radio Interface Protocol Aspects (Release 7)" Marked-Up; Oct. 2005 (18 pages).

3GPP TR 25.814 V0.3.1 "3rd Generation Partnership Project; Technical Specification Group Radio Access Network; Physical Layer Aspects for Evolved UTRA (Release 7)" Oct. 2005 (51 pages).

3GPP TR 25.814 V1.0.2 (Jan. 2006) "3rd Generation Partnership Project; Technical Specification Group Radio Access Network; Physical Layer Aspects for Evolved UTRA (Release 7)" Marked-Up; Jan. 2006; 79 pages.

(56)

References Cited

OTHER PUBLICATIONS

3GPP TR 25.905 V7.0.0 (Dec. 2006) "3rd Generation Partnership Project; Technical Specification Group Radio Access Network; Improvement of the Multimedia Broadcast Multicast Service (MBMS) in UTRAN (Release 7)" Dec. 2006; 41 pages.

3GPP TR 25.912 V7.0.0 "3rd Generation Partnership Project; Technical Specification Group Radio Access Network; Feasibility Study for Evolved Universal Terrestrial Radio Access (UTRA) and Universal Terrestrial Radio Access Network (E-UTRAN) (Release 7)" Jun. 2006 (55 pages).

3GPP TS 36.101 V8.2.0 (May 2008) "3rd Generation Partnership Project; Technical Specification Group Radio Access Network; Evolved Universal Terrestrial Radio Access (E-UTRA); User Equipment (UE) Radio Transmission and Reception (Release 8)" May 2008; 66 pages.

3GPP TS 36.211 V8.0.0 (Sep. 2007) "3rd Generation Partnership Project; Technical Specification Group Radio Access Network; Evolved Universal Terrestrial Radio Access (E-UTRA); Physical Channels and Modulation (Release 8)" Sep. 2007; 50 pages.

3GPP TS 36.213 V8.3.0 (May 2008) "3rd Generation Partnership Project; Technical Specification Group Radio Access Network; Evolved Universal Terrestrial Radio Access (E-UTRA); Physical Layer Procedures (Release 8)" May 2008; 45 pages.

3GPP TS 36.300 V8.0.0 (Mar. 2007) "3rd Generation Partnership Project; Technical Specification Group Radio Access Network; Evolved Universal Terrestrial Radio Access (E-UTRA) and Evolved Universal Terrestrial Radio Access Network (E-UTRAN); Overall Description; Stage 2 (Release 8)" Mar. 2007; 82 pages.

3GPP TS 36.300 V8.1.0 (Jun. 2007) "3rd Generation Partnership Project; Technical Specification Group Radio Access Network; Evolved Universal Terrestrial Radio Access (E-UTRA) and Evolved Universal Terrestrial Radio Access Network (E-UTRAN); Overall Description; Stage 2 (Release 8)" Jun. 2007 (106 pages).

3GPP TS 36.300 V8.2.0 (Sep. 2007) "3rd Generation Partnership Project; Technical Specification Group Radio Access Network; Evolved Universal Terrestrial Radio Access (E-UTRA) and Evolved Universal Terrestrial Radio Access Network (E-UTRAN); Overall Description; Stage 2 (Release 8)" Sep. 2007; 109 pages.

3GPP TS 36.300 V8.3.0 (Dec. 2007) "3rd Generation Partnership Project; Technical Specification Group Radio Access Network; Evolved Universal Terrestrial Radio Access (E-UTRA) and Evolved Universal Terrestrial Radio Access Network (E-UTRAN); Overall Description; Stage 2 (Release 8)" Dec. 2007; 121 pages.

3GPP TS 36.300 V8.4.0 (Mar. 2008) "3rd Generation Partnership Project; Technical Specification Group Radio Access Network; Evolved Universal Terrestrial Radio Access (E-UTRA) and Evolved Universal Terrestrial Radio Access Network (E-UTRAN); Overall Description; Stage 2 (Release 8)" Mar. 2008; 126 pages.

3GPP TS 36.300 V8.5.0 "3rd Generation Partnership Project; Technical Specification Group Radio Access Network; Evolved Universal Terrestrial Radio Access (E-UTRA) and Evolved Universal Terrestrial Radio Access Network (E-UTRAN); Overall Description; Stage 2 (Release 8)" May 2008 (134 pages).

3GPP TS 36.300 V8.6.0 (Sep. 2008) "3rd Generation Partnership Project; Technical Specification Group Radio Access Network; Evolved Universal Terrestrial Radio Access (E-UTRA) and Evolved Universal Terrestrial Radio Access Network (E-UTRAN); Overall Description; Stage 2 (Release 8)" Sep. 2008 (137 pages).

3GPP TS 36.300 V8.7.0 "3rd Generation Partnership Project; Technical Specification Group Radio Access Network; Evolved Universal Terrestrial Radio Access (E-UTRA) and Evolved Universal Terrestrial Radio Access Network (E-UTRAN); Overall Description; Stage 2 (Release 8)" Dec. 2008 (144 pages).

3GPP TS 36.300 V8.8.0 "3rd Generation Partnership Project; Technical Specification Group Radio Access Network; Evolved Universal Terrestrial Radio Access (E-UTRA) and Evolved Universal Terrestrial Radio Access Network (E-UTRAN); Overall Description; Stage 2 (Release 8)" Mar. 2009 (156 pages).

3GPP TS 36.300 V8.9.0 (Jun. 2009) "3rd Generation Partnership Project; Technical Specification Group Radio Access Network;

Evolved Universal Terrestrial Radio Access (E-UTRA) and Evolved Universal Terrestrial Radio Access Network (E-UTRAN); Overall Description; Stage 2 (Release 8)" Jun. 2009 (159 pages).

3GPP TS 36.300 V0.9.0 (Marked-Up) "3rd Generation Partnership Project; Technical Specification Group Radio Access Network; Evolved Universal Terrestrial Radio Access (E-UTRA) and Evolved Universal Terrestrial Radio Access Network (E-UTRAN); Overall Description; Stage 2" Mar. 2007 (87 pages).

3GPP TS 36.300 V0.9.0 "3rd Generation Partnership Project; Technical Specification Group Radio Access Network; Evolved Universal Terrestrial Radio Access (E-UTRA) and Evolved Universal Terrestrial Radio Access Network (E-UTRAN); Overall Description; Stage 2" Mar. 2007 (81 pages).

3GPP TS 36.321 V8.1.0. "3rd Generation Partnership Project; Technical Specification Group Access Network; Evolved Universal Terrestrial Radio Access (E-UTRA) Medium Access Control (MAC) protocol specification" (Release 8) 30 pages, Mar. 2008.

3GPP TS 36.321 V8.2.0 "3rd Generation Partnership Project; Technical Specification Group Radio Access Network; Evolved Universal Terrestrial Radio Access (E-UTRA) Medium Access Control (MAC) Protocol Specification (Release 8)" May 2008 (33 pages).

3GPP TS 36.321 V8.2.0 "3rd Generation Partnership Project; Technical Specification Group Radio Access Network; Evolved Universal Terrestrial Radio Access (E-UTRA) Medium Access Control (MAC) Protocol Specification (Release 8)" May 2008 (32 pages).

3GPP TS 36.321 V8.3.0 "3rd Generation Partnership Project; Technical Specification Group Radio Access Network; Evolved Universal Terrestrial Radio Access (E-UTRA) Medium Access Control (MAC) Protocol Specification (Release 8)" Sep. 2008 (36 pages).

3GPP TS 36.331 V8.0.0 (Dec. 2007) "3rd Generation Partnership Project; Technical Specification Group Radio Access Network; Evolved Universal Terrestrial Radio Access (E-UTRA) Radio Resource Control (RRC); Protocol Specification (Release 8)" Dec. 2007 (56 pages).

3GPP TS 36.331 V8.1.0 (Mar. 2008) "3rd Generation Partnership Project; Technical Specification Group Radio Access Network; Evolved Universal Terrestrial Radio Access (E-UTRA) Radio Resource Control (RRC); Protocol Specification (Release 8)" Mar. 2008 (122 pages).

3GPP TS 36.331 V8.2.0 (May 2008) "3rd Generation Partnership Project; Technical Specification Group Radio Access Network; Evolved Universal Terrestrial Radio Access (E-UTRA) Radio Resource Control (RRC); Protocol Specification (Release 8)" May 2008 (151 pages).

3GPP TS 36.331 V8.3.0 (Sep. 2008) "3rd Generation Partnership Project; Technical Specification Group Radio Access Network; Evolved Universal Terrestrial Radio Access (E-UTRA) Radio Resource Control (RRC); Protocol Specification (Release 8)" Sep. 2008 (178 pages).

3GPP TS 36.331 V8.4.0 (Dec. 2008) "3rd Generation Partnership Project; Technical Specification Group Radio Access Network; Evolved Universal Terrestrial Radio Access (E-UTRA) Radio Resource Control (RRC); Protocol Specification (Release 8)" Dec. 2008 (198 pages).

3GPP TS 36.331 V8.5.0 (Mar. 2009) "3rd Generation Partnership Project; Technical Specification Group Radio Access Network; Evolved Universal Terrestrial Radio Access (E-UTRA) Radio Resource Control (RRC); Protocol Specification (Release 8)" Mar. 2009 (204 pages).

3GPP TS 36.331 V8.6.0 (Jun. 2009) "3rd Generation Partnership Project; Technical Specification Group Radio Access Network; Evolved Universal Terrestrial Radio Access (E-UTRA) Radio Resource Control (RRC); Protocol Specification (Release 8)" Jun. 2009 (207 pages).

Abramson, Norman "The Aloha System—Another Alternative for Computer Communications" University of Hawaii; Honolulu, Hawaii; Fall Joint Computer Conference, 1970; 6 pages.

Chu, David C. "Polyphase Codes with Good Periodic Correlation Properties" Information Theory IEEE Transaction on, vol. 18, Issue 4, pp. 531-532, Jul. 1972).

Dahlman, Erik "3G Evolution HSPA and LTE for Mobile Broadband" Academic Press; 2007; 18 pages.

(56)

References Cited

OTHER PUBLICATIONS

Ericsson "Clarification of DL- and UL-SCH Data Transfer" 3GPP TSG-RAN2 Meeting #62bis; R2-0837271 Warsaw, Poland; Jun. 30-Jul. 4 2008 (7 pages).

ETSI TS 101 475 V1.3.1 "Broadband Radio Access Networks (BRAN); HIPERLAN Type 2; Physical (PHY) Layer" Dec. 2001 (43 pages).

ETSI TS 101 761-1 V1.3.1 "Broadband Radio Access Networks (BRAN); HIPERLAN Type 2; Data Link Control (DLC) Layer; Part 1: Basic Data Transport Functions" Dec. 2001 (88 pages).

ETSI TS 136 321 V8.2.0 "LTE; Evolved Universal Terrestrial Radio Access (E-UTRA); Medium Access Control (MAC) Protocol Specification (3GPP TS 36.321 Version 8.2.0 Release 8)" Nov. 2008 (35 pages).

Holma, Harri et al. "WCDMA for UMTS: Radio Access for Third Generation Mobile Communications" 3rd Edition; Wiley; 2004; 481 pages.

IEEE "Minutes of IEEE 802.16 Session #38" IEEE 802.16 Broadband Wireless Access Working Group; Aug. 25, 2005 (44 pages).

IEEE "IEEE 802.16e Handoff Draft" IEEE C802.16e-03/20r1; Mar. 13, 2003 (22 pages).

IEEE "IEEE 802.16 Standard for Local and Metropolitan Area Networks: Part 16: Air Interface for Fixed Broadband Wireless Access Systems" Oct. 1, 2004 (895 pages).

IEEE "Signaling Methodologies to Support Closed-Loop Transmit Processing in TDD-OFDMA" {IEEE C802.16e-04/103r2; Jul. 7, 2004 (35 pages).

IEEE Computer Society et al. "IEEE Standard for Local and Metropolitan Area Networks: Part 16: Air Interface for Fixed Broadband wireless Access Systems 802.16" Oct. 2004.

IEEE "Draft IEEE Standard for Local and Metropolitan Area Networks: Part 16: Air Interface for Fixed and Mobile Broadband Wireless Access Systems" IEEE P802.16e/D12, Oct. 14, 2005 (684 Pages).

IEEE "IEEE Standard for Local and Metropolitan Area Networks: Part 16: Air Interface for Fixed and Mobile Broadband Wireless Access Systems; Amendment 2: Physical and Medium Access Control Layers for Combined Fixed and Mobile Operation in Licensed Bands" IEEE P802.16e-2005; Feb. 28, 2006 (864 Pages).

Joint RAN2-RAN3 #48bis LTE "EUTRAN Handover Procedure for LTE_ACTIVE" Cannes, France; TSGR3(05)1106; Oct. 11-14, 2005 (3 pages).

LG Electronics "Functions of E-RRC and E-MAC" TSG-RAN Working Group 2 #48bis, R2-052768, Cannes, France, Oct. 10-14, 2005.

Natarajan, Balasubramaniarn et al, "High-Performance MC-CDMA Via Carrier Interferometry Codes" IEEE Transactions on Vehicular Technology, vol. 60, No. 6, Nov. 2001; 10 pages.

Nokia "Intra-Radio Access Mobility, Handover in LTE_ACTIVE" 3GPP TSG-RAN WG2#50, R2-060053; Sophia Antipolis, France, Jan. 8-13, 2006.

Nokia, NTT DoCoMo "Intra-LTE Handover Operation" 3GPP TSG-RAN WG2 Meeting #53, R2-061135, Shanghai, PRC, May 8-13, 2006.

Nokia, NTT DoCoMo "E-UTRA Transport Channels" 3GPP TSG-RAN WG2 Meeting #48bis; R2-052438, Cannes, France; Oct. 10-14, 2005.

NTT DoCoMo "Physical Channel Structures for Evolved UTRA" 3GPP TSG RAN WG1 Meeting #41; R1-050464; Athens, Greece, May 9-13, 2005.

NTT DoCoMo, NEC, Sharp Physical Channels and Multiplexing in Evolved UTRA Downlink: 3GPP TSG RAN WG1 #42 on LTE; R1-050707 (Original R1-050590); London, UK, Aug. 29-Sep. 2, 2005.

Nuaymi, Loutfi "WiMAX: Technology for Broadband Wireless Access" John Wiley & Sons, Ltd., 2007 (286 pages).

Onoe, Seizo et al. "Control Channel Structure for TDMA Mobile Radio Systems" NTT Radio Communication Systems Laboratories; 40th IEEE Vehicular Technology Conference, May 6-9, 1990, Orlando (US), pp. 270-275.

Popovic, Branislav M. "Generalized Chirp-Like Polyphase Sequences with Optimum Correlation Properties" IEEE Transactions on Information Theory, vol. 38, No. 4. Jul. 1992 (4 pages).

Sesia, Stefania "LTE: The UMTS Long Term Evolution: From Theory to Practice" Second Edition; Wiley; 2011 (794 pages).

Tsai, Shang Ho et al. "MAI-Free MC-CDMA Systems Based on Hadamard-Walsh Codes" IEEE Transactions on Signal Processing, vol. 54, No. 8, Aug. 2006 (14 pages).

TSG-RAN Working Group 1 Meeting #6 "Proposal for RACH Preambles" Espoo, Finland; Jul. 13-16, 1999; 3GPP/TSGR1#6(99)893; 26 pages.

TSG-RAN Meeting #41 "REL-8 CRs for LTE to TS 36.321 MAC" Kobe, Japan; RP-080690; Sep. 9-12, 2008; (3 pages).

TSG-RAN WG1 #42bis "Multiplexing Method of Shared Control Channel in Uplink Single-Carrier FDMA Radio Access" NTT DoCoMo, Fujitsu, Mitsubishi Electric Corporation, NEC, Panasonic, Sharp, Toshiba Corporation, R1-051143 (Original R1-050591), San Diego, USA, Oct. 10-14, 2005.

TSG-RAN WG1 #43 E-UTRA Random Access: Seoul, Korea; Nov. 7-11, 2005; R1-051445; 4 pages.

TSG-RAN Meeting #43 "RAN2 REL-8 CRs for LTE to TS 36.300" Biarritz, France; RP-090123; Mar. 3-6, 2009 (1 page).

TSG-RAN WG1 Meeting #44 "RACH Preamble Evaluation in E-UTRA Uplink" Denver, USA; R1-060700; Feb. 13-17, 2006 (5 pages).

TSG-RAN WG1 Meeting #44bis "Random Access Burst Evaluation in E-UTRA Uplink" Athens, Greece; R1-060792I Mar. 27-31, 2006 (8 pages).

TSG-RAN WG1 Meeting #45 "Random Access Design for E-UTRA Uplink" Shanghai, China; R1-061114; May 8-12, 2006 (5 pages).

TSG-RAN WG1 Meeting #45 "Random Access Design for E-UTRA Uplink" Shanghai, China; R1-061114; Marked-Up; May 8-12, 2006 (6 pages).

TSG-RAN WG1 #46 "E-UTRA Scalability of Random Access Preamble with Cyclic Prefix" Tallinn, Estonia; R1-062274; Aug. 28-Sep. 1, 2006 (8 pages).

TSG-RAN Working Group 1 Meeting #63bis "Report of 3GPP TSG RAN WG2 Meeting #63" Prague, Czech Republic; Oct. 18-22, 2008; R2-085971; 156 pages.

Wu, Yik-Chung et al. "Maximum-Likelihood Symbol Synchronization for IEEE 802.11a WLANs in Unknown Frequency-Selective Fading Channels" IEEE Transactions on Wireless Communications, vol. 4, No. 6, Nov. 2005 (13 pages).

Notification of Reason for Refusal (Including Translation) for Korean Application No. 10-2006-0063135, dated Nov. 20, 2009.

Notification of Reason for Final Refusal (Including Translation) for Korean Application No. 10-2006-0063135, dated May 18, 2010.

Decision to Grant (Including Translation) for Korean Application No. 10-2006-0063135, dated Aug. 25, 2010.

International Search Report for corresponding International Patent Application No. PCT/KR2006/003697, dated Dec. 20, 2006.

Written Opinion for corresponding International Patent Application No. PCT/KR2006/003697, dated Dec. 20, 2006.

International Preliminary Report on Patentability for corresponding International Patent Application No. PCT/KR2006/003697, dated May 6, 2008.

Examiner's Report for Australian Patent Application No. 2006323560, dated Jun. 3, 2009.

Notice of Acceptance for Australian Patent Application No. 2006323560, dated Aug. 28, 2009.

Notification of First Office Action (including translation) for Chinese Patent Application No. 200680040518.1, dated Mar. 3, 2011.

Notification of Second Office Action (including translation) for Chinese Patent Application No. 200680040518.1, dated May 5, 2011.

Rejection Decision (including translation) for Chinese Patent Application No. 200680040518.1, dated Jul. 28, 2011.

Notice of Decision of Granting Patent Right for Invention (including translation) for Chinese Patent Application No. 200680040518.1, dated Oct. 28, 2011.

European Search Report for European Patent Application No. 06847353.7, dated Dec. 21, 2011.

(56)

References Cited

OTHER PUBLICATIONS

Communication Pursuant to Rules 70(2) and 70a(2) EPC for European Patent Application No. 06847353.7, dated Jan. 10, 2012.

Office Action for European Patent Application No. 06847353.7, dated Apr. 13, 2015.

Office Action for European Patent Application No. 06847353.7, dated Feb. 26, 2016.

Intention to Grant for European Patent Application No. 06847353.7, dated Jun. 9, 2016.

European Search Report for European Patent Application No. 16002537, dated Mar. 27, 2017.

Office Action for European Patent Application No. 16002537, dated Apr. 10, 2017.

Official Action for Indian Patent Application No. 1324/KOLNP/2008, dated Apr. 23, 2014.

Hearing Notice for Indian Patent Application No. 1324/KOLNP/2008, dated May 27, 2015.

Official Action (Including Translation) for Japanese Patent Application No. 2008-533234, dated Oct. 7, 2010.

Official Action (Including Translation) for Japanese Patent Application No. 2008-533234, dated Dec. 13, 2010.

Notice of Allowance (Including Translation) for Japanese Patent Application No. 2008-533234, dated Jan. 13, 2011.

Official Action (Including Translation) for Mexican Patent Application No. MX/a/2008/004924, dated May 21, 2010.

Notice of Allowance (Including Translation) for Mexican Patent Application No. MX/a/2008/004924, dated Jul. 1, 2010.

Official Action (including translation) for Russian Patent Application No. 2008113180, dated Dec. 1, 2009.

Notice of Allowance (including translation) for Russian Patent Application No. 2008113180, dated Jun. 4, 2010.

Official Letter for Taiwan Patent Application No. 95138124, dated Jan. 28, 2011.

Official Letter and Search Report (including translation) for Taiwan Patent Application No. 95138124, dated Feb. 1, 2011.

Notice of Allowance (including translation) for Taiwan Patent Application No. 95138124, dated Sep. 23, 2011.

Official Action for U.S. Appl. No. 11/553,939, dated Mar. 5, 2009.

Official Action for U.S. Appl. No. 11/553,939, dated Jun. 15, 2009.

Official Action for U.S. Appl. No. 11/553,939, dated Dec. 28, 2009.

Notice of Allowance for U.S. Appl. No. 11/553,939, dated May 28, 2010.

Official Action for U.S. Appl. No. 12/870,747 dated Jan. 25, 2011.

Official Action for U.S. Appl. No. 12/870,747 dated Apr. 19, 2011.

Official Action for U.S. Appl. No. 12/870,747 dated Nov. 10, 2011.

Notice of Allowance for U.S. Appl. No. 12/870,747 dated Apr. 12, 2012.

Supplemental Notice of Allowance for U.S. Appl. No. 12/870,747 dated Jun. 4, 2012.

Official Action for U.S. Appl. No. 13/487,081 dated Aug. 28, 2012.

Notice of Allowance for U.S. Appl. No. 13/487,081 dated Jan. 4, 2013.

Ex Parte Quayle Action for U.S. Appl. No. 14/326,637 dated Mar. 25, 2015.

Non-Final Office Action for U.S. Appl. No. 14/326,637 dated Aug. 25, 2016.

Non-Final Office Action for U.S. Appl. No. 14/326,637 dated May 12, 2017.

Notice of Allowance for U.S. Appl. No. 14/326,637 dated Sep. 26, 2017.

Non-Final Office Action for U.S. Appl. No. 14/723,093 dated Aug. 25, 2016.

Final Office Action for U.S. Appl. No. 14/723,093 dated Aug. 22, 2017.

Notice of Allowance for U.S. Appl. No. 14/723,093 dated Sep. 26, 2017.

Non-Final Office Action for U.S. Appl. No. 14/676,490 dated Sep. 21, 2016.

Final Office Action for U.S. Appl. No. 14/676,490 dated Jul. 10, 2017.

Notice of Allowance for U.S. Appl. No. 14/676,490 dated Aug. 21, 2017.

Defendants' Initial Invalidity Contentions; In the United States District Court for the District of Delaware; Civil Action Nos. 1:15-cv-00542-SLR-SRF; 1:15-cv-00543-SLR-SRF; 1:15-cv-00544-SLR-SRF; 1:15-cv-00545-SLR-SRF; 1:15-cv-00546-SLR-SRF; 1:15-cv-00547-SLR-SRF; filed Mar. 14, 2016 (1244 pages).

Defendants' Invalidity Contentions; In the United States District Court for the District of Delaware; Civil Action Nos. 1:15-cv-00542-SLR-SRF; 1:15-cv-00543-SLR-SRF; 1:15-cv-00544-SLR-SRF; 1:15-cv-00545-SLR-SRF; 1:15-cv-00546-SLR-SRF; 1:15-cv-00547-SLR-SRF; filed Feb. 28, 2017 (3,140 pages).

Documents filed with U.S. District Court Proceedings for *Evolved Wireless, LLC v. Apple Inc.*; U.S. District Court, for the District of Delaware (Wilmington); Civil Action No. 1:15-cv-00542-SLR-SRF; Includes documents filed from Jun. 25, 2015-May 13, 2016 Docket Nos. 1-53; (1259 pages).

Documents filed with U.S. District Court Proceedings for *Evolved Wireless, LLC v. Apple Inc.*; U.S. District Court, for the District of Delaware (Wilmington); Civil Action No. 1:15-cv-00542-SLR-SRF; Includes documents filed from May 17, 2016-Jul. 11, 2016—Docket Nos. 54-67; (4,028 pages).

Documents filed with U.S. District Court Proceedings for *Evolved Wireless, LLC v. Apple Inc.*; U.S. District Court, for the District of Delaware (Wilmington); Civil Action No. 1:15-cv-00542-SLR-SRF; Includes documents filed from Jul. 15, 2016-Aug. 19, 2016—Docket Nos. 68-76; (308 pages).

Documents filed with U.S. District Court Proceedings for *Evolved Wireless, LLC v. Apple Inc.*; U.S. District Court, for the District of Delaware (Wilmington); Civil Action No. 1:15-cv-00542-SLR-SRF; Includes documents filed from Aug. 23, 2016-Nov. 8, 2016 Docket Nos. 77-108; (785 pages).

Documents filed with U.S. District Court Proceedings for *Evolved Wireless, LLC v. Apple Inc.*; U.S. District Court, for the District of Delaware (Wilmington); Civil Action No. 1:15-cv-00542-SLR-SRF; Includes documents filed from Nov. 9, 2016-Dec. 12, 2016; Docket Nos. 109-119; (212 pages).

Documents filed with U.S. District Court Proceedings for *Evolved Wireless, LLC v. Apple Inc.*; U.S. District Court, for the District of Delaware (Wilmington); Civil Action No. 1:15-cv-00542-SLR-SRF; Includes documents filed from Dec. 27, 2016-Jan. 17, 2017; Docket Nos. 120-122; (9 pages).

Documents filed with U.S. District Court Proceedings for *Evolved Wireless, LLC v. Apple Inc.*; U.S. District Court, for the District of Delaware (Wilmington); Civil Action No. 1:15-cv-00542-SLR-SRF; Includes documents filed from Jan. 25, 2017-Mar. 17, 2017; Docket Nos. 123-145; (176 pages).

Documents filed with U.S. District Court Proceedings for *Evolved Wireless, LLC v. Apple Inc.*; U.S. District Court, for the District of Delaware (Wilmington); Civil Action No. 1:15-cv-00542-SLR-SRF; Includes documents filed from Mar. 20, 2017-May 30, 2017; Docket Nos. 146-157; (175 pages).

Documents filed with U.S. District Court Proceedings for *Evolved Wireless, LLC v. Apple Inc.*; U.S. District Court, for the District of Delaware (Wilmington); Civil Action No. 1:15-cv-00542-SLR-SRF; Includes documents filed from Jun. 14, 2017-Aug. 25, 2017; Docket Nos. 158-189; (257 pages).

Documents filed with U.S. District Court Proceedings for *Evolved Wireless, LLC v. Apple Inc.*; U.S. District Court, for the District of Delaware (Wilmington); Civil Action No. 1:15-cv-00542-SLR-SRF; Includes documents filed from Aug. 31, 2017-Oct. 5, 2017; Docket Nos. 190-219; (307 pages).

Documents filed with U.S. District Court Proceedings for *Evolved Wireless, LLC v. Apple Inc.*; U.S. District Court, for the District of Delaware (Wilmington); Civil Action No. 1:15-cv-00542-SLR-SRF; Includes documents filed from Oct. 6, 2017-Jan. 3, 2018; Docket Nos. 220-308; (5,058 pages).

Documents filed with U.S. District Court Proceedings for *Evolved Wireless, LLC v. HTC Corporation et al.*; U.S. District Court, for the District of Delaware (Wilmington); Civil Action No. 1:15-cv-00543-SLR-SRF; Includes documents filed from Jun. 25, 2015-May 13, 2016 Docket Nos. 1-54; (1369 pages).

(56)

References Cited

OTHER PUBLICATIONS

Documents filed with U.S. District Court Proceedings for *Evolved Wireless, LLC v. Samsung Electronics Co. Ltd., et al.*; U.S. District Court, for the District of Delaware (Wilmington); Civil Action No. 1:15-cv-00545-SLR-SRF; Includes documents filed from Mar. 21, 2017-May 30, 2017; Docket Nos. 169-183; (185 pages).

Documents filed with U.S. District Court Proceedings for *Evolved Wireless, LLC v. Samsung Electronics Co. Ltd., et al.*; U.S. District Court, for the District of Delaware (Wilmington); Civil Action No. 1:15-cv-00545-SLR-SRF; Includes documents filed from Jun. 14, 2017-Aug. 25, 2017; Docket Nos. 184-221; (281 pages).

Documents filed with U.S. District Court Proceedings for *Evolved Wireless, LLC v. Samsung Electronics Co. Ltd., et al.*; U.S. District Court, for the District of Delaware (Wilmington); Civil Action No. 1:15-cv-00545-SLR-SRF; Includes documents filed from Aug. 31, 2017-Sep. 28, 2017; Docket Nos. 222-244; (241 pages).

Documents filed with U.S. District Court Proceedings for *Evolved Wireless, LLC v. Samsung Electronics Co. Ltd., et al.*; U.S. District Court, for the District of Delaware (Wilmington); Civil Action No. 1:15-cv-00545-SLR-SRF; Includes documents filed from Oct. 6, 2017-Jan. 3, 2018; Docket Nos. 245-312; (3,694 pages).

Documents filed with U.S. District Court Proceedings for *Evolved Wireless, LLC v. ZTE Corporation*; U.S. District Court, for the District of Delaware (Wilmington); Civil Action No. 1:15-cv-00546-SLR-SRF; Includes documents filed from Jun. 25, 2015-May 17, 2016 Docket Nos. 1-57; (1203 pages).

Documents filed with U.S. District Court Proceedings for *Evolved Wireless, LLC v. ZTE Corporation*; U.S. District Court, for the District of Delaware (Wilmington); Civil Action No. 1:15-cv-00546-SLR-SRF; Includes documents filed from Jun. 1, 2016-Jul. 11, 2016; Docket Nos. 58-70; (4,001 pages).

Documents filed with U.S. District Court Proceedings for *Evolved Wireless, LLC v. ZTE Corporation*; U.S. District Court, for the District of Delaware (Wilmington); Civil Action No. 1:15-cv-00546-SLR-SRF; Includes documents filed from Jul. 15, 2016-Aug. 19, 2016; Docket Nos. 71-79; (308 pages).

Documents filed with U.S. District Court Proceedings for *Evolved Wireless, LLC v. ZTE Corporation*; U.S. District Court, for the District of Delaware (Wilmington); Civil Action No. 1:15-cv-00546-SLR-SRF; Includes documents filed from Aug. 23, 2016-Nov. 8, 2016; Docket Nos. 80-113; (733 pages).

Documents filed with U.S. District Court Proceedings for *Evolved Wireless, LLC v. ZTE Corporation*; U.S. District Court, for the District of Delaware (Wilmington); Civil Action No. 1:15-cv-00546-SLR-SRF; Includes documents filed from Nov. 9, 2016-Dec. 7, 2016; Docket Nos. 114-124; (212 pages).

Documents filed with U.S. District Court Proceedings for *Evolved Wireless, LLC v. ZTE Corporation*; U.S. District Court, for the District of Delaware (Wilmington); Civil Action No. 1:15-cv-00546-SLR-SRF; Includes documents filed from Dec. 27, 2016-Jan. 17, 2017; Docket Nos. 125-127; (9 pages).

Documents filed with U.S. District Court Proceedings for *Evolved Wireless, LLC v. ZTE Corporation*; U.S. District Court, for the District of Delaware (Wilmington); Civil Action No. 1:15-cv-00546-SLR-SRF; Includes documents filed from Jan. 25, 2017-Mar. 17, 2017; Docket Nos. 128-153; (135 pages).

Documents filed with U.S. District Court Proceedings for *Evolved Wireless, LLC v. ZTE Corporation*; U.S. District Court, for the District of Delaware (Wilmington); Civil Action No. 1:15-cv-00546-SLR-SRF; Includes documents filed from Mar. 20, 2017-May 30, 2017; Docket Nos. 154-165; (178 pages).

Documents filed with U.S. District Court Proceedings for *Evolved Wireless, LLC v. ZTE Corporation*; U.S. District Court, for the District of Delaware (Wilmington); Civil Action No. 1:15-cv-00546-SLR-SRF; Includes documents filed from Jun. 14, 2017-Aug. 25, 2017; Docket Nos. 166-193; (254 pages).

Documents filed with U.S. District Court Proceedings for *Evolved Wireless, LLC v. ZTE Corporation*; U.S. District Court, for the District of Delaware (Wilmington); Civil Action No. 1:15-cv-00546-

SLR-SRF; Includes documents filed from Aug. 31, 2017-Sep. 28, 2017; Docket Nos. 194-218; (244 pages).

Documents filed with U.S. District Court Proceedings for *Evolved Wireless, LLC v. ZTE Corporation*; U.S. District Court, for the District of Delaware (Wilmington); Civil Action No. 1:15-cv-00546-SLR-SRF; Includes documents filed from Oct. 6, 2017-Jan. 3, 2018; Docket Nos. 219-276; (3,378 pages).

Documents filed with U.S. District Court Proceedings for *Evolved Wireless, LLC v. Microsoft Corporation, et al.*; U.S. District Court, for the District of Delaware (Wilmington); Civil Action No. 1:15-cv-00547-SLR-SRF; Includes documents filed from Jun. 25, 2015-May 17, 2016 Docket Nos. 1-57; (1273 pages).

Documents filed with U.S. District Court Proceedings for *Evolved Wireless, LLC v. Microsoft Corporation, et al.*; U.S. District Court, for the District of Delaware (Wilmington); Civil Action No. 1:15-cv-00547-SLR-SRF; Includes documents filed from May 18, 2016-Jul. 11, 2016—Docket Nos. 58-69; (3,996 pages).

Documents filed with U.S. District Court Proceedings for *Evolved Wireless, LLC v. Microsoft Corporation, et al.*; U.S. District Court, for the District of Delaware (Wilmington); Civil Action No. 1:15-cv-00547-SLR-SRF; Includes documents filed from Jul. 15, 2016-Aug. 19, 2016—Docket Nos. 70-78; (305 pages).

Documents filed with U.S. District Court Proceedings for *Evolved Wireless, LLC v. Microsoft Corporation, et al.*; U.S. District Court, for the District of Delaware (Wilmington); Civil Action No. 1:15-cv-00547-SLR-SRF; Includes documents filed from Aug. 24, 2016-Nov. 8, 2016—Docket Nos. 79-113; (796 pages).

Documents filed with U.S. District Court Proceedings for *Evolved Wireless, LLC v. Microsoft Corporation, et al.*; U.S. District Court, for the District of Delaware (Wilmington); Civil Action No. 1:15-cv-00547-SLR-SRF; Includes documents filed from Nov. 9, 2016-Dec. 14, 2016—Docket Nos. 114-129; (129 pages).

Documents filed with U.S. District Court Proceedings for *Evolved Wireless, LLC v. Microsoft Corporation, et al.*; U.S. District Court, for the District of Delaware (Wilmington); Civil Action No. 1:15-cv-00547-SLR-SRF; Includes documents filed from Dec. 19, 2016-Jan. 17, 2017; Docket Nos. 130-133; (11 pages).

Documents filed with U.S. District Court Proceedings for *Evolved Wireless, LLC v. Microsoft Corporation, et al.*; U.S. District Court, for the District of Delaware (Wilmington); Civil Action No. 1:15-cv-00547-SLR-SRF; Includes documents filed from Jan. 25, 2017-Mar. 17, 2017; Docket Nos. 134-151; (98 pages).

Documents filed with U.S. District Court Proceedings for *Evolved Wireless, LLC v. Microsoft Corporation, et al.*; U.S. District Court, for the District of Delaware (Wilmington); Civil Action No. 1:15-cv-00547-SLR-SRF; Includes documents filed from Mar. 21, 2017-May 30, 2017; Docket Nos. 151-165; (176 pages).

Documents filed with U.S. District Court Proceedings for *Evolved Wireless, LLC v. Microsoft Corporation, et al.*; U.S. District Court, for the District of Delaware (Wilmington); Civil Action No. 1:15-cv-00547-SLR-SRF; Includes documents filed from Jun. 5, 2017-Aug. 25, 2017; Docket Nos. 166-192; (155 pages).

Documents filed with U.S. District Court Proceedings for *Evolved Wireless, LLC v. Microsoft Corporation, et al.*; U.S. District Court, for the District of Delaware (Wilmington); Civil Action No. 1:15-cv-00547-SLR-SRF; Includes documents filed from Aug. 31, 2017-Sep. 28, 2017; Docket Nos. 193-218; (232 pages).

Documents filed with U.S. District Court Proceedings for *Evolved Wireless, LLC v. Microsoft Corporation, et al.*; U.S. District Court, for the District of Delaware (Wilmington); Civil Action No. 1:15-cv-00547-SLR-SRF; Includes documents filed from Oct. 6, 2017-Jan. 3, 2018; Docket Nos. 219-289; (3,748 pages).

Petition for *Inter Partes* Review of U.S. Pat. No. 7,809,373, including Exhibits 1001-1019, Case No. IPR2016-01185, filed Jun. 20, 2016 (3,522 pages).

Notice of Filing Date Accorded to Petition and Time for Filing Patent Owner Preliminary Response for *Apple Inc. v. Evolved Wireless, LLC*, United States Patent and Trademark Office—Before the Patent Trial and Appeal Board, Case No. IPR 2016-01185, filed Jun. 28, 2016 (5 pages).

(56)

References Cited

OTHER PUBLICATIONS

Patent Owner's Mandatory Disclosures for *Apple Inc. v. Evolved Wireless, LLC*, United States Patent and Trademark Office—Before the Patent Trial and Appeal Board, Case No. IPR 2016-01185, filed Jul. 11, 2016 (9 pages).

Patent Owner's Preliminary Response for *Apple Inc. v. Evolved Wireless, LLC*, United States Patent and Trademark Office—Before the Patent Trial and Appeal Board, Case No. IPR 2016-01185, filed Sep. 28, 2016 (149 pages).

Decision Denying Institution of *Inter Partes* Review 37 C.F.R. 42.108 for *Apple Inc. v. Evolved Wireless, LLC*, United States Patent and Trademark Office—Before the Patent Trial and Appeal Board, Case No. IPR 2016-01185, filed Dec. 19, 2016 (18 pages).

Petitioner's Request for Rehearing Pursuant to 37 C.F.R. 42.71 for *Apple Inc. v. Evolved Wireless, LLC*, United States Patent and Trademark Office—Before the Patent Trial and Appeal Board, Case No. IPR 2016-01185, filed Jan. 18, 2017 (17 pages).

Decision—Denying Request for Rehearing for *Apple Inc. v. Evolved Wireless, LLC*, United States Patent and Trademark Office—Before the Patent Trial and Appeal Board, Case No. IPR 2016-01185, filed Apr. 17, 2017 (8 pages).

Petitioner's Request for Refund of Post-Institution Fees for *Apple Inc. v. Evolved Wireless, LLC*, United States Patent and Trademark Office—Before the Patent Trial and Appeal Board, Case No. IPR 2016-01185, filed Apr. 21, 2017 (3 pages).

Notice of Refund for *Apple Inc. v. Evolved Wireless, LLC*, United States Patent and Trademark Office—Before the Patent Trial and Appeal Board, Case No. IPR 2016-01185, filed May 1, 2017 (2 pages).

Petition for *Inter Partes* Review of U.S. Pat. No. 7,809,373, including Exhibits 1001-1019, Case No. IPR2016-01347, filed Jul. 5, 2016 (3,520 pages).

Notice of Filing Date Accorded to Petition and Time for Filing Patent Owner Preliminary Response for *Samsung Electronics Co., Ltd. et al., v. Evolved Wireless, LLC*, United States Patent and Trademark Office—Before the Patent Trial and Appeal Board, Case No. IPR 2016-01347, filed Jul. 13, 2016 (5 pages).

Patent Owner's Mandatory Disclosures for *Samsung Electronics Co., Ltd. et al., v. Evolved Wireless, LLC*, United States Patent and Trademark Office—Before the Patent Trial and Appeal Board, Case No. IPR 2016-01347, submitted Aug. 4, 2016 (9 pages).

Patent Owner's Preliminary Response for *Samsung Electronics Co., Ltd. et al., v. Evolved Wireless, LLC*, United States Patent and Trademark Office—Before the Patent Trial and Appeal Board, Case No. IPR 2016-01347, submitted Oct. 13, 2016 (156 pages).

Decision Denying Institution of *Inter Partes* Review 37 C.F.R. 42.108 for *Samsung Electronics Co., Ltd. et al., v. Evolved Wireless, LLC*, United States Patent and Trademark Office—Before the Patent Trial and Appeal Board, Case No. IPR 2016-01347, submitted Dec. 19, 2016 (19 pages).

Petitioner's Request for Rehearing Pursuant to 37 C.F.R. 42.71 for *Samsung Electronics Co., Ltd. et al., v. Evolved Wireless, LLC*, United States Patent and Trademark Office—Before the Patent Trial and Appeal Board, Case No. IPR 2016-01347, submitted Jan. 18, 2017 (17 pages).

Petitioner's Updated Mandatory Notice Under 37 C.F.R. § 42.8(b)(3) for *Samsung Electronics Co., Ltd. et al., v. Evolved Wireless, LLC*, United States Patent and Trademark Office—Before the Patent Trial and Appeal Board, Case No. IPR 2016-01347, submitted Apr. 7, 2017 (4 pages).

Decision—Denying Request for Rehearing—37 C.F.R. § 42.71(d) for *Samsung Electronics Co., Ltd. et al., v. Evolved Wireless, LLC*, United States Patent and Trademark Office—Before the Patent Trial and Appeal Board, Case No. IPR 2016-01347, submitted Apr. 17, 2017 (8 pages).

3GPP TS 25.301 V6.4.0 “3rd Generation Partnership Project; Technical Specification Group Radio Access Network; Radio Interface Protocol Architecture (Release 6)” XP50129425 Sep. 2005 (48 pages).

3GPP TR 23.882 V1.4.0 “3rd Generation Partnership Project; Technical Specification Group Services and System Aspects; 3GPP System Architecture Evolution: Report on Technical Options and Conclusions (Release 7)” XP50364109; Sep. 2006 (159 pages).
Office Action for European Patent Application No. 17020418.4, dated Oct. 8, 2019.

Documents filed with U.S. District Court Proceedings for *Evolved Wireless, LLC v. Apple Inc.*; U.S. District Court, for the District of Delaware (Wilmington); Civil Action No. 1:15-cv-00542-SLR-SRF; Includes documents filed from Aug. 30, 2019-Sep. 5, 2019; Docket Nos. 546-548; (6 pages).

Documents filed with U.S. District Court Proceedings for *Evolved Wireless, LLC v. HTC Corporation et al.*; U.S. District Court, for the District of Delaware (Wilmington); Civil Action No. 1:15-cv-00543-SLR-SRF; Includes documents filed from Aug. 29, 2019-Oct. 11, 2019; Docket Nos. 432-435; (17 pages).

Documents filed with U.S. District Court Proceedings for *Evolved Wireless, LLC v. Motorola Mobility, et al.*; U.S. District Court, for the District of Delaware (Wilmington); Civil Action No. 1:15-cv-00544-SLR-SRF; Includes documents filed from Aug. 29, 2019-Oct. 11, 2019; Docket Nos. 394-397; (17 pages).

Documents filed with U.S. District Court Proceedings for *Evolved Wireless, LLC v. Samsung Electronics Co. Ltd., et al.*; U.S. District Court, for the District of Delaware (Wilmington); Civil Action No. 1:15-cv-00545-SLR-SRF; Includes documents filed from Aug. 29, 2019-Oct. 11, 2019; Docket Nos. 477-480; (17 pages).

Documents filed with U.S. District Court Proceedings for *Evolved Wireless, LLC v. ZTE Corporation*; U.S. District Court, for the District of Delaware (Wilmington); Civil Action No. 1:15-cv-00546-SLR-SRF; Includes documents filed from Aug. 29, 2019-Oct. 11, 2019; Docket Nos. 397-400; (17 pages).

Documents filed with U.S. District Court Proceedings for *Evolved Wireless, LLC v. Microsoft Corporation, et al.*; U.S. District Court, for the District of Delaware (Wilmington); Civil Action No. 1:15-cv-00547-SLR-SRF; Includes documents filed from Aug. 29, 2019-Oct. 11, 2019; Docket Nos. 415-418; (17 pages).

Documents filed with U.S. Court of Appeals for the Federal Circuit for *Evolved Wireless, LLC v. ZTE (USA) Inc.*; Appeal Docket No. 18-2008; Includes documents filed from May 25, 2018-Oct. 4, 2019; Docket Nos. 1-130; (4386 pages).

Documents filed with U.S. Court of Appeals for the Federal Circuit for *Evolved Wireless, LLC v. Samsung Electronics Co., Ltd.*; Appeal Docket No. 18-2009; Includes documents filed from May 25, 2018-Oct. 4, 2019; Docket Nos. 1-6; (110 pages).

Documents filed with U.S. Court of Appeals for the Federal Circuit for *Evolved Wireless, LLC v. Apple Inc.*; Appeal Docket No. 18-2010; Includes documents filed from May 25, 2018-Oct. 4, 2019; Docket Nos. 1-24; (216 pages).

Documents filed with U.S. Court of Appeals for the Federal Circuit for *Evolved Wireless, LLC v. Apple Inc.*; Appeal Docket No. 18-2011; Includes documents filed from May 25, 2018-Oct. 4, 2019; Docket Nos. 1-5; (162 pages).

Documents filed with U.S. Court of Appeals for the Federal Circuit for *Evolved Wireless, LLC v. Apple Inc.*; Appeal Docket No. 19-2362; Includes documents filed from Sep. 5, 2019-Oct. 21, 2019; Docket Nos. 1-15; (102 pages).

Intent to Grant for European Patent Application No. 16002537, dated Oct. 30, 2018.

Office Action for European Patent Application No. 17020418.4, dated Oct. 8, 2018.

Documents filed with U.S. District Court Proceedings for *Evolved Wireless, LLC v. Apple Inc.*; U.S. District Court, for the District of Delaware (Wilmington); Civil Action No. 1:15-cv-00542-SLR-SRF; Includes documents filed from Apr. 23, 2018-Jun. 28, 2018; Docket Nos. 380-392; (205 pages).

Documents filed with U.S. District Court Proceedings for *Evolved Wireless, LLC v. HTC Corporation et al.*; U.S. District Court, for the District of Delaware (Wilmington); Civil Action No. 1:15-cv-00543-SLR-SRF; Includes documents filed from Apr. 23, 2018-Jun. 28, 2018; Docket Nos. 373-383; (156 pages).

Documents filed with U.S. District Court Proceedings for *Evolved Wireless, LLC v. Lenovo Group Ltd., et al.*; U.S. District Court, for the District of Delaware (Wilmington); Civil Action No. 1:15-cv-

(56)

References Cited

OTHER PUBLICATIONS

00544-SLR-SRF; Includes documents filed from Apr. 23, 2018-Jun. 28, 2018; Docket Nos. 338-346; (114 pages).

Documents filed with U.S. District Court Proceedings for *Evolved Wireless, LLC v. Samsung Electronics Co. Ltd., et al.*; U.S. District Court, for the District of Delaware (Wilmington); Civil Action No. 1:15-cv-00545-SLR-SRF; Includes documents filed from Apr. 23, 2018-Jun. 28, 2018; Docket Nos. 378-389; (114 pages).

Documents filed with U.S. District Court Proceedings for *Evolved Wireless, LLC v. ZTE Corporation*; U.S. District Court, for the District of Delaware (Wilmington); Civil Action No. 1:15-cv-00546-SLR-SRF; Includes documents filed from Apr. 23, 2018-Jun. 28, 2018; Docket Nos. 340-348; (114 pages).

Documents filed with U.S. District Court Proceedings for *Evolved Wireless, LLC v. Microsoft Corporation, et al.*; U.S. District Court, for the District of Delaware (Wilmington); Civil Action No. 1:15-cv-00547-SLR-SRF; Includes documents filed from Apr. 23, 2018-Jun. 28, 2018; Docket Nos. 359-364; (58 pages).

Office Action for European Patent Application No. 16002537, dated Jan. 24, 2018.

European Search Report for European Patent Application No. 17020418.4, dated Jan. 25, 2018.

European Search Report for European Patent Application No. 17020418.4, dated Mar. 9, 2018.

3GPP TSG-RAN WG2 #50 "Handover Procedure for LTE-ACTIVE UEs" Sophia-Antipolis, France; R2-060078; Jan. 9-13, 2006 (6 pages).

3GPP TR 25.813 V7.0.0 "3rd Generation Partnership Project" Technical Specification Group Radio Access Network; Evolved Universal Terrestrial Radio Access (E-UTRA) and Evolved Universal Terrestrial Radio Access Network (E-UTRAN); Radio Interface Protocol Aspects (Release 7) (Jun. 2006); 39 pages.

TSG-RAN Working Group 2 Adhoc on LTE "Random Access Procedures" Cannes, France; R2-061881; Jun. 27-30, 2006; 4 pages.

Documents filed with U.S. District Court Proceedings for *Evolved Wireless, LLC v. Apple Inc.*; U.S. District Court, for the District of Delaware (Wilmington); Civil Action No. 1:15-cv-00542-SLR-SRF; Includes documents filed from Dec. 31, 2018-Mar. 28, 2019; Docket Nos. 433-510; (2342 pages).

Documents filed with U.S. District Court Proceedings for *Evolved Wireless, LLC v. HTC Corporation et al.*; U.S. District Court, for the District of Delaware (Wilmington); Civil Action No. 1:15-cv-00543-SLR-SRF; Includes documents filed from Dec. 31, 2018-Mar. 28, 2019; Docket Nos. 409-428; (154 pages).

Documents filed with U.S. District Court Proceedings for *Evolved Wireless, LLC v. Motorola Mobility, et al.*; U.S. District Court, for the District of Delaware (Wilmington); Civil Action No. 1:15-cv-00544-SLR-SRF; Includes documents filed from Dec. 31, 2018-Mar. 28, 2019; Docket Nos. 372-391; (140 pages).

Documents filed with U.S. District Court Proceedings for *Evolved Wireless, LLC v. Samsung Electronics Co. Ltd., et al.*; U.S. District Court, for the District of Delaware (Wilmington); Civil Action No. 1:15-cv-00545-SLR-SRF; Includes documents filed from Dec. 31, 2018-Mar. 28, 2019; Docket Nos. 429-474; (774 pages).

Documents filed with U.S. District Court Proceedings for *Evolved Wireless, LLC v. ZTE Corporation*; U.S. District Court, for the District of Delaware (Wilmington); Civil Action No. 1:15-cv-00546-SLR-SRF; Includes documents filed from Dec. 31, 2018-Mar. 28, 2019; Docket Nos. 376-394; (138 pages).

Documents filed with U.S. District Court Proceedings for *Evolved Wireless, LLC v. Microsoft Corporation, et al.*; U.S. District Court, for the District of Delaware (Wilmington); Civil Action No. 1:15-cv-00547-SLR-SRF; Includes documents filed from Dec. 31, 2018-Mar. 28, 2019; Docket Nos. 394-412; (134 pages).

Intent to Grant or European Application No. 19164548.0, dated Nov. 4, 2019.

Documents filed with U.S. District Court Proceedings for *Evolved Wireless, LLC v. Apple Inc.*; U.S. District Court, for the District of Delaware (Wilmington); Civil Action No. 1:15-cv-00542-SLR-

SRF; Includes documents filed from Nov. 15, 2019-Dec. 17, 2019; Docket Nos. 549-552; (31 pages).

Documents filed with U.S. District Court Proceedings for *Evolved Wireless, LLC v. HTC Corporation et al.*; U.S. District Court, for the District of Delaware (Wilmington); Civil Action No. 1:15-cv-00543-SLR-SRF; Includes documents filed from Nov. 1, 2019-Jan. 8, 2020; Docket Nos. 436-448; (63 pages).

Documents filed with U.S. District Court Proceedings for *Evolved Wireless, LLC v. Motorola Mobility, et al.*; U.S. District Court, for the District of Delaware (Wilmington); Civil Action No. 1:15-cv-00544-SLR-SRF; Includes documents filed from Nov. 15, 2019-Jan. 13, 2020; Docket Nos. 398-414; (70 pages).

Documents filed with U.S. District Court Proceedings for *Evolved Wireless, LLC v. Samsung Electronics Co. Ltd., et al.*; U.S. District Court, for the District of Delaware (Wilmington); Civil Action No. 1:15-cv-00545-SLR-SRF; Includes documents filed from Nov. 15, 2019-Jan. 17, 2020; Docket Nos. 481-493; (65 pages).

Documents filed with U.S. District Court Proceedings for *Evolved Wireless, LLC v. ZTE Corporation*; U.S. District Court, for the District of Delaware (Wilmington); Civil Action No. 1:15-cv-00546-SLR-SRF; Includes documents filed from Nov. 15, 2019-Jan. 8, 2020; Docket Nos. 401-411; (61 pages).

Documents filed with U.S. District Court Proceedings for *Evolved Wireless, LLC v. Microsoft Corporation, et al.*; U.S. District Court, for the District of Delaware (Wilmington); Civil Action No. 1:15-cv-00547-SLR-SRF; Includes documents filed from Nov. 15, 2019-Jan. 8, 2020; Docket Nos. 419-431; (62 pages).

Documents filed with U.S. Court of Appeals for the Federal Circuit for *Evolved Wireless, LLC v. ZTE (USA) Inc.*; Appeal Docket No. 18-2008; Includes documents filed on Nov. 15, 2019; Docket No. 131; (2 pages).

Documents filed with U.S. Court of Appeals for the Federal Circuit for *Evolved Wireless, LLC v. Samsung Electronics Co., Ltd.*; Appeal Docket No. 18-2009; Includes documents filed on Nov. 25, 2019; Docket No. 7; (2 pages).

Documents filed with U.S. Court of Appeals for the Federal Circuit for *Evolved Wireless, LLC v. Apple Inc.*; Appeal Docket No. 18-2010; Includes documents filed on Nov. 25, 2019; Docket No. 25; (2 pages).

Documents filed with U.S. Court of Appeals for the Federal Circuit for *Evolved Wireless, LLC v. Apple Inc.*; Appeal Docket No. 18-2011; Includes documents filed on Nov. 25, 2019; Docket No. 6; (2 pages).

Documents filed with U.S. Court of Appeals for the Federal Circuit for *Evolved Wireless, LLC v. Apple Inc.*; Appeal Docket No. 19-2362; Includes documents filed from Dec. 4, 2019-Jan. 27, 2020; Docket Nos. 16-21; (224 pages).

Documents filed with U.S. Court of Appeals for the Federal Circuit for *Evolved Wireless, LLC v. HTC Corporation*; Appeal Docket No. 2020-1335; Includes documents filed from Jan. 8, 2020-Jan. 27, 2020; Docket Nos. 1-36; (158 pages).

Documents filed with U.S. Court of Appeals for the Federal Circuit for *Evolved Wireless, LLC v. Motorola Mobility, LLC*; Appeal Docket No. 2020-1337; Includes documents filed from Jan. 8, 2020-Jan. 24, 2020; Docket Nos. 1-9; (95 pages).

Documents filed with U.S. Court of Appeals for the Federal Circuit for *Evolved Wireless, LLC v. ZTE(USA) Inc.*; Appeal Docket No. 2020-1339; Includes documents filed from Jan. 8, 2020-Jan. 23, 2020; Docket Nos. 1-9; (63 pages).

Documents filed with U.S. Court of Appeals for the Federal Circuit for *Evolved Wireless, LLC v. Microsoft Corporation*; Appeal Docket No. 2020-1340; Includes documents filed from Jan. 8, 2020-Jan. 21, 2020; Docket Nos. 1-3; (52 pages).

Documents filed with U.S. Court of Appeals for the Federal Circuit for *Evolved Wireless, LLC v. Samsung Electronics Co., Ltd.*; Appeal Docket No. 2020-1363; Includes documents filed from Jan. 17, 2020-Jan. 21, 2020; Docket Nos. 1-3; (59 pages).

Documents filed with U.S. District Court Proceedings for *Evolved Wireless, LLC v. Apple Inc.*; U.S. District Court, for the District of Delaware (Wilmington); Civil Action No. 1:15-cv-00542-SLR-SRF; Includes documents filed from Jan. 5, 2018-Apr. 16, 2018; Docket Nos. 309-379; (1198 pages).

(56)

References Cited

OTHER PUBLICATIONS

Documents filed with U.S. District Court Proceedings for *Evolved Wireless, LLC v. HTC Corporation et al.*; U.S. District Court, for the District of Delaware (Wilmington); Civil Action No. 1:15-cv-00543-SLR-SRF; Includes documents filed from Jan. 5, 2018-Apr. 16, 2018; Docket Nos. 309-372; (3,169 pages).

Documents filed with U.S. District Court Proceedings for *Evolved Wireless, LLC v. Lenovo Group Ltd., et al.*; U.S. District Court, for the District of Delaware (Wilmington); Civil Action No. 1:15-cv-00544-SLR-SRF; Includes documents filed from Jan. 5, 2018-Apr. 16, 2018; Docket Nos. 274-337; (1,456 pages).

Documents filed with U.S. District Court Proceedings for *Evolved Wireless, LLC v. Samsung Electronics Co. Ltd., et al.*; U.S. District Court, for the District of Delaware (Wilmington); Civil Action No. 1:15-cv-00545-SLR-SRF; Includes documents filed from Jan. 5, 2018-Apr. 16, 2018; Docket Nos. 313-377; (1,508 pages).

Documents filed with U.S. District Court Proceedings for *Evolved Wireless, LLC v. ZTE Corporation*; U.S. District Court, for the District of Delaware (Wilmington); Civil Action No. 1:15-cv-00546-SLR-SRF; Includes documents filed from Jan. 5, 2018-Apr. 16, 2018; Docket Nos. 277-339; (1,196 pages).

Documents filed with U.S. District Court Proceedings for *Evolved Wireless, LLC v. Microsoft Corporation, et al.*; U.S. District Court, for the District of Delaware (Wilmington); Civil Action No. 1:15-cv-00547-SLR-SRF; Includes documents filed from Jan. 5, 2018-Apr. 16, 2018; Docket Nos. 290-358; (1,476 pages).

Documents filed with U.S. District Court Proceedings for *Evolved Wireless, LLC v. Apple Inc.*; U.S. District Court, for the District of Delaware (Wilmington); Civil Action No. 1:15-cv-00542-SLR-SRF; Includes documents filed from Jul. 10, 2018-Aug. 24, 2018; Docket Nos. 393-408; (91 pages).

Documents filed with U.S. District Court Proceedings for *Evolved Wireless, LLC v. HTC Corporation et al.*; U.S. District Court, for the District of Delaware (Wilmington); Civil Action No. 1:15-cv-00543-SLR-SRF; Includes documents filed from Jul. 24, 2018-Aug. 24, 2018; Docket Nos. 384-402; (139 pages).

Documents filed with U.S. District Court Proceedings for *Evolved Wireless, LLC v. Motorola Mobility, et al.*; U.S. District Court, for the District of Delaware (Wilmington); Civil Action No. 1:15-cv-00544-SLR-SRF; Includes documents filed from Jul. 24, 2018-Aug. 24, 2018; Docket Nos. 347-365; (139 pages).

Documents filed with U.S. District Court Proceedings for *Evolved Wireless, LLC v. Samsung Electronics Co. Ltd., et al.*; U.S. District Court, for the District of Delaware (Wilmington); Civil Action No. 1:15-cv-00545-SLR-SRF; Includes documents filed from Jul. 24, 2018-Aug. 24, 2018; Docket Nos. 387-401; (89 pages).

Documents filed with U.S. District Court Proceedings for *Evolved Wireless, LLC v. ZTE Corporation*; U.S. District Court, for the District of Delaware (Wilmington); Civil Action No. 1:15-cv-00546-SLR-SRF; Includes documents filed from Jul. 24, 2018-Aug. 24, 2018; Docket Nos. 349-369; (141 pages).

Documents filed with U.S. District Court Proceedings for *Evolved Wireless, LLC v. Microsoft Corporation, et al.*; U.S. District Court, for the District of Delaware (Wilmington); Civil Action No. 1:15-cv-00547-SLR-SRF; Includes documents filed from Jul. 5, 2018-Aug. 24, 2018; Docket Nos. 365-385; (136 pages).

Documents filed with U.S. District Court Proceedings for *Evolved Wireless, LLC v. HTC Corporation et al.*; U.S. District Court, for the District of Delaware (Wilmington); Civil Action No. 1:15-cv-00543-SLR-SRF; Includes documents filed from Jan. 5, 2018-Apr. 16m 2018; Docket Nos. 309-372; (3,169 pages).

Documents filed with U.S. District Court Proceedings for *Evolved Wireless, LLC v. Apple Inc.*; U.S. District Court, for the District of Delaware (Wilmington); Civil Action No. 1:15-cv-00542-SLR-SRF; Includes documents filed from Sep. 21, 2018-Oct. 3, 2018; Docket Nos. 409-432; (349 pages).

Documents filed with U.S. District Court Proceedings for *Evolved Wireless, LLC v. HTC Corporation et al.*; U.S. District Court, for the District of Delaware (Wilmington); Civil Action No. 1:15-cv-00543-

SLR-SRF; Includes documents filed from Sep. 4, 2018-Oct. 3, 2018; Docket Nos. 403-408; (60 pages).

Documents filed with U.S. District Court Proceedings for *Evolved Wireless, LLC v. Motorola Mobility, et al.*; U.S. District Court, for the District of Delaware (Wilmington); Civil Action No. 1:15-cv-00544-SLR-SRF; Includes documents filed from Sep. 4, 2018-Oct. 3, 2018; Docket Nos. 363-371; (60 pages).

Documents filed with U.S. District Court Proceedings for *Evolved Wireless, LLC v. Samsung Electronics Co. Ltd., et al.*; U.S. District Court, for the District of Delaware (Wilmington); Civil Action No. 1:15-cv-00545-SLR-SRF; Includes documents filed from Aug. 30, 2018-Oct. 3, 2018; Docket Nos. 402-428; (389 pages).

Documents filed with U.S. District Court Proceedings for *Evolved Wireless, LLC v. ZTE Corporation*; U.S. District Court, for the District of Delaware (Wilmington); Civil Action No. 1:15-cv-00546-SLR-SRF; Includes documents filed from Sep. 4, 2018-Oct. 3, 2018; Docket Nos. 370-375; (60 pages).

Documents filed with U.S. District Court Proceedings for *Evolved Wireless, LLC v. Microsoft Corporation, et al.*; U.S. District Court, for the District of Delaware (Wilmington); Civil Action No. 1:15-cv-00547-SLR-SRF; includes documents filed from Aug. 28, 2018-Oct. 3, 2018; Docket Nos. 386-393; (61 pages).

Examination Report for Indian Application No. 1093/KOLNP/2015, dated May 30, 2019.

Documents filed with U.S. District Court Proceedings for *Evolved Wireless, LLC v. Apple Inc.*; U.S. District Court, for the District of Delaware (Wilmington); Civil Action No. 1:15-cv-00542-SLR-SRF; Includes documents filed from Apr. 2, 2019-Jun. 7, 2019; Docket Nos. 511-537; (233 pages).

Documents filed with U.S. District Court Proceedings for *Evolved Wireless, LLC v. HTC Corporation et al.*; U.S. District Court, for the District of Delaware (Wilmington); Civil Action No. 1:15-cv-00543-SLR-SRF; Includes documents filed on May 1, 2019; Docket No. 429; (3 pages).

Documents filed with U.S. District Court Proceedings for *Evolved Wireless, LLC v. Motorola Mobility, et al.*; U.S. District Court, for the District of Delaware (Wilmington); Civil Action No. 1:15-cv-00544-SLR-SRF; Includes documents filed on May 1, 2019; Docket No. 392; (3 pages).

Documents filed with U.S. District Court Proceedings for *Evolved Wireless, LLC v. Samsung Electronics Co. Ltd., et al.*; U.S. District Court, for the District of Delaware (Wilmington); Civil Action No. 1:15-cv-00545-SLR-SRF; Includes documents filed on May 1, 2019; Docket No. 475; (3 pages).

Documents filed with U.S. District Court Proceedings for *Evolved Wireless, LLC v. ZTE Corporation*; U.S. District Court, for the District of Delaware (Wilmington); Civil Action No. 1:15-cv-00546-SLR-SRF; Includes documents filed on May 1, 2019; Docket No. 395; (3 pages).

Documents filed with U.S. District Court Proceedings for *Evolved Wireless, LLC v. Microsoft Corporation, et al.*; U.S. District Court, for the District of Delaware (Wilmington); Civil Action No. 1:15-cv-00547-SLR-SRF; Includes documents filed on May 1, 2019; Docket No. 413; (2 pages).

Office Action for U.S. Appl. No. 15/824,609, dated Apr. 27, 2020.

Documents filed with U.S. District Court Proceedings for *Evolved Wireless, LLC v. Samsung Electronics Co. Ltd., et al.*; U.S. District Court, for the District of Delaware (Wilmington); Civil Action No. 1:15-cv-00545-SLR-SRF; Includes documents filed Feb. 13, 2020; Docket No. 494; (2 pages).

Documents filed with U.S. Court of Appeals for the Federal Circuit for *Evolved Wireless, LLC v. Apple Inc.*; Appeal Docket No. 19-2362; Includes documents filed from Feb. 12, 2020-Feb. 28, 2020; Docket Nos. 22-24; (73 pages).

Documents filed with U.S. Court of Appeals for the Federal Circuit for *Evolved Wireless, LLC v. HTC Corporation*; Appeal Docket No. 2020-1335; Includes documents filed from Jan. 27, 2020-Jan. 31, 2020; Docket Nos. 37-40; (9 pages).

U.S. Appl. No. 11/553,939, filed Oct. 27, 2006 U.S. Pat. No. 7,809,373.

U.S. Appl. No. 12/870,747, filed Aug. 27, 2010 U.S. Pat. No. 8,219,097.

(56)

References Cited

OTHER PUBLICATIONS

U.S. Appl. No. 13/487,081, filed Jun. 1, 2012 U.S. Pat. No. 8,412,201.

U.S. Appl. No. 14/676,490, filed Apr. 1, 2015 U.S. Pat. No. Re. 46,602.

U.S. Appl. No. 14/326,637, filed Jul. 9, 2014 U.S. Pat. No. Re. 46,679.

U.S. Appl. No. 14/723,093, filed May 27, 2015 U.S. Pat. No. Re. 46,714.

U.S. Appl. No. 15/824,609, filed Nov. 28, 2017.

European Search Report for European Application No. 20164685.8, dated Jul. 7, 2020.

Documents filed with U.S. District Court Proceedings for *Evolved Wireless, LLC v. Apple Inc.*; U.S. District Court, for the District of Delaware (Wilmington); Civil Action No. 1:15-cv-00542-SLR-SRF; Includes documents filed on Jun. 23, 2020; (2 pages).

Documents filed with U.S. District Court Proceedings for *Evolved Wireless, LLC v. HTC Corporation et al.*; U.S. District Court, for the

District of Delaware (Wilmington); Civil Action No. 1:15-cv-00543-SLR-SRF; Includes documents on Sep. 3, 2020; (643 pages).

Documents filed with U.S. District Court Proceedings for *Evolved Wireless, LLC v. Motorola Mobility, et al.*; U.S. District Court, for the District of Delaware (Wilmington); Civil Action No. 1:15-cv-00544-SLR-SRF; Includes documents on Sep. 3, 2020; (643 pages).

Documents filed with U.S. District Court Proceedings for *Evolved Wireless, LLC v. Samsung Electronics Co. Ltd., et al.*; U.S. District Court, for the District of Delaware (Wilmington); Civil Action No. 1:15-cv-00545-SLR-SRF; Includes documents filed Sep. 3, 2020; Docket No. 495; (643 pages).

Documents filed with U.S. District Court Proceedings for *Evolved Wireless, LLC v. ZTE Corporation*; U.S. District Court, for the District of Delaware (Wilmington); Civil Action No. 1:15-cv-00546-SLR-SRF; Includes documents filed Sep. 3, 2020; (643 pages).

Documents filed with U.S. District Court Proceedings for *Evolved Wireless, LLC v. Microsoft Corporation, et al.*; U.S. District Court, for the District of Delaware (Wilmington); Civil Action No. 1:15-cv-00547-SLR-SRF; Includes documents filed Sep. 3, 2020; (1286 pages).

* cited by examiner

Fig 1

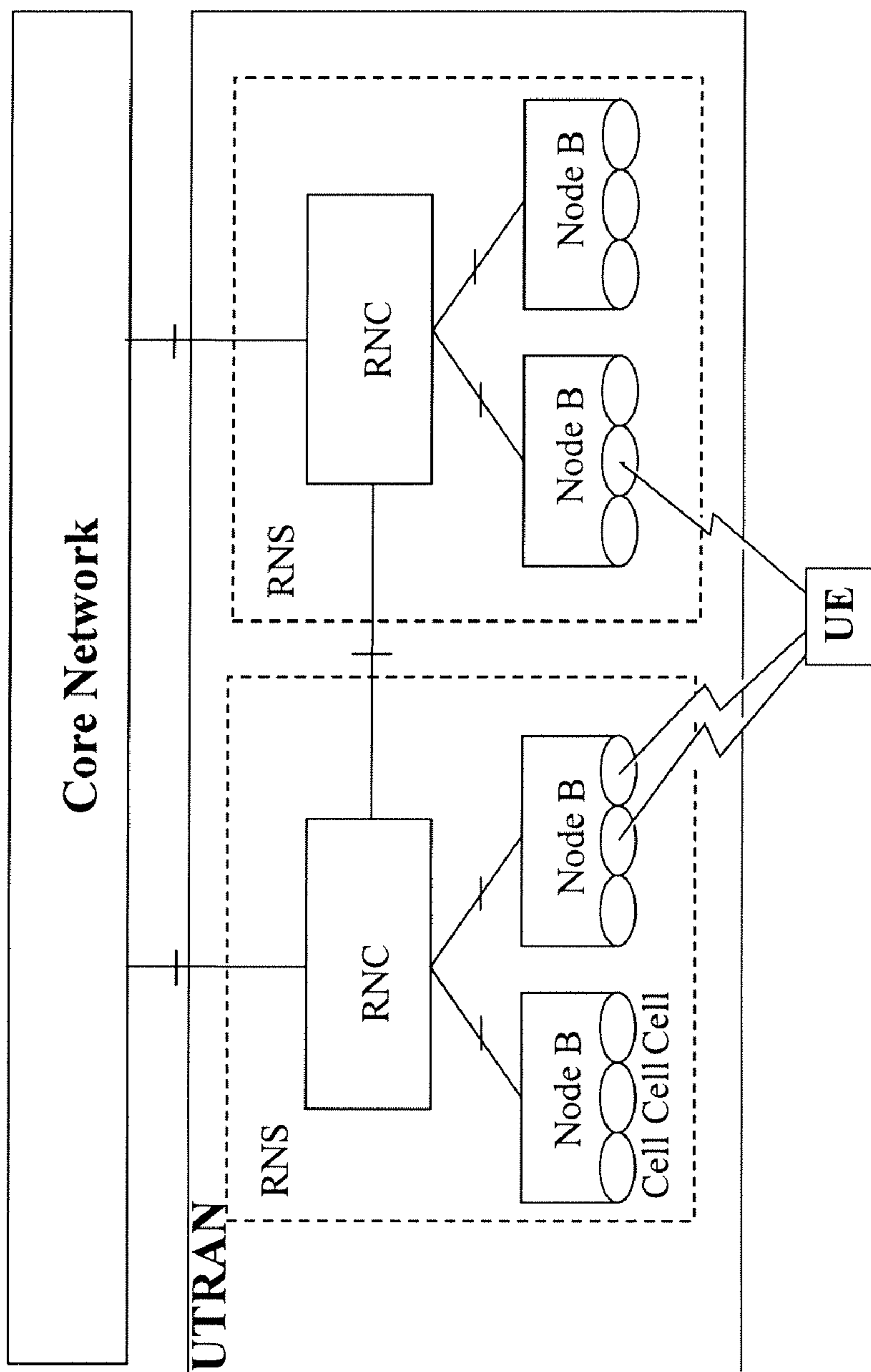

Fig 2

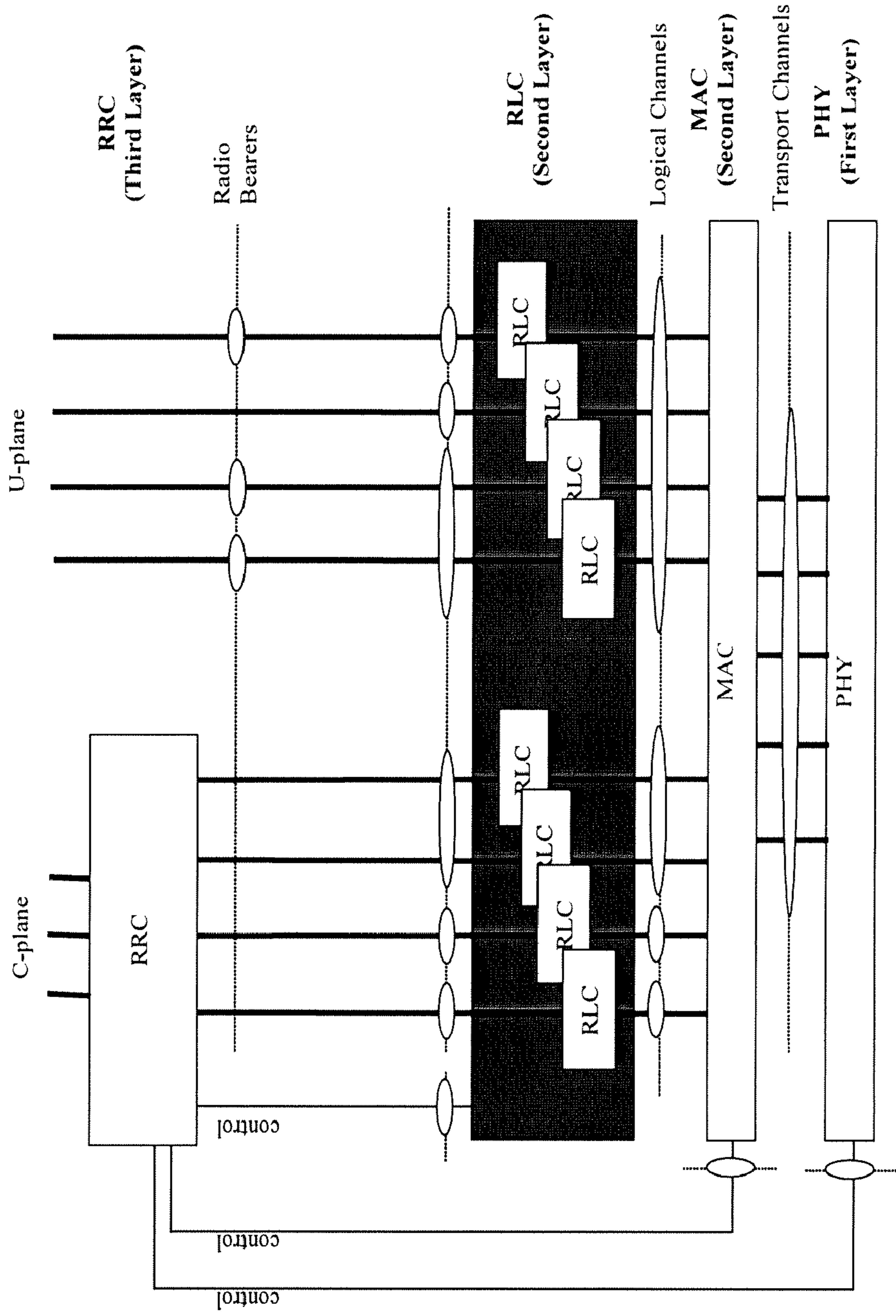

Fig 3

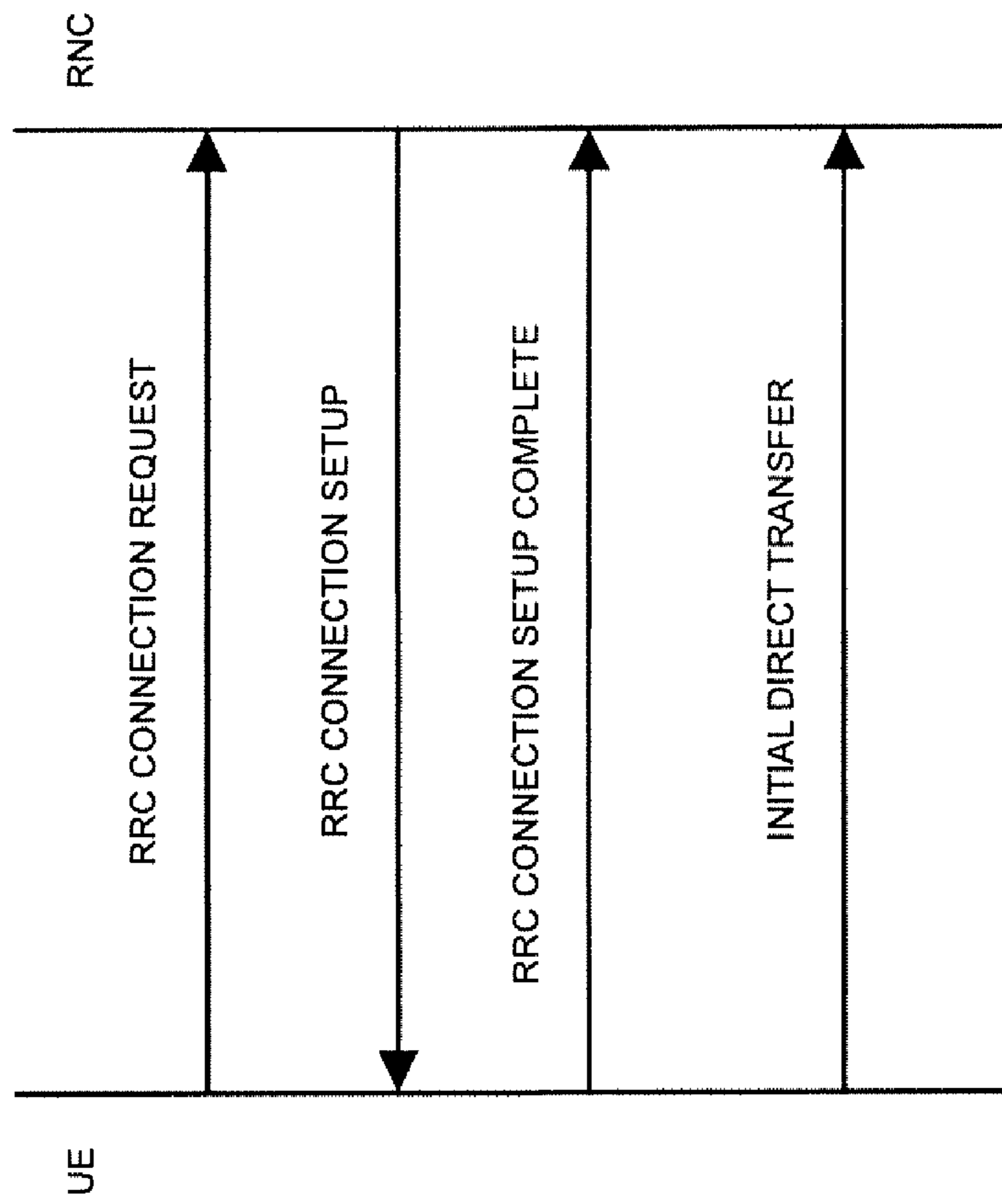

Fig 5

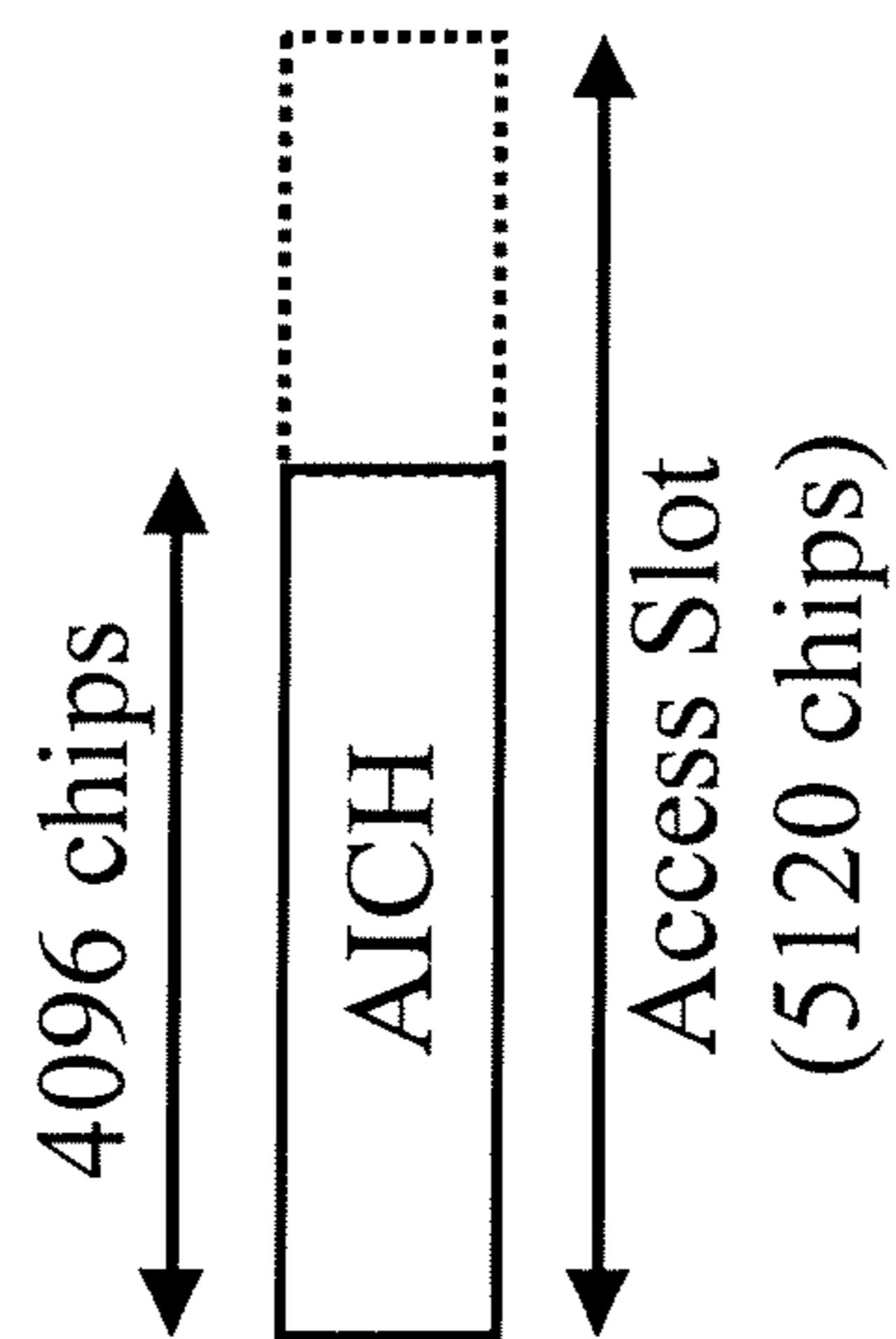

Fig 4

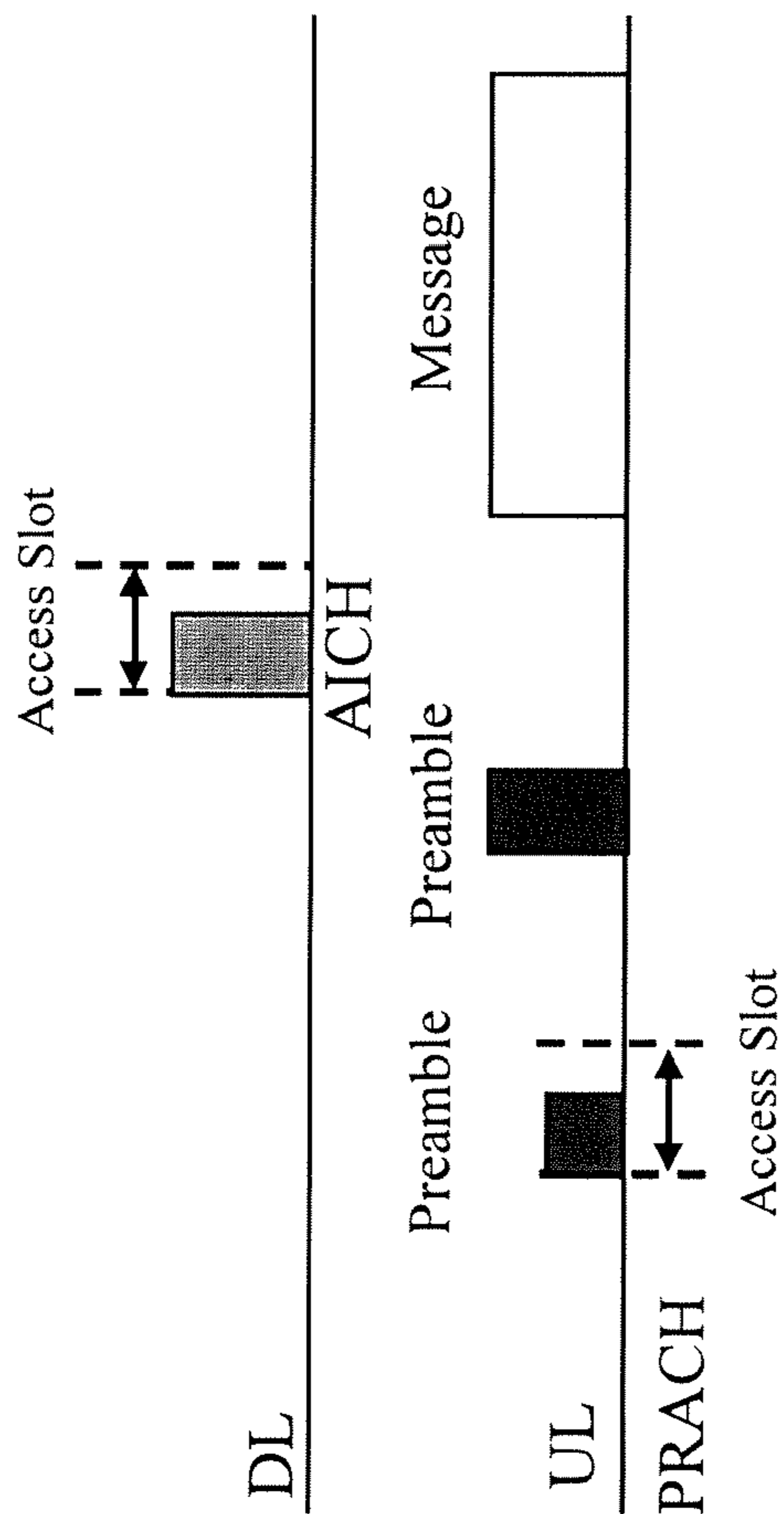

Fig 6

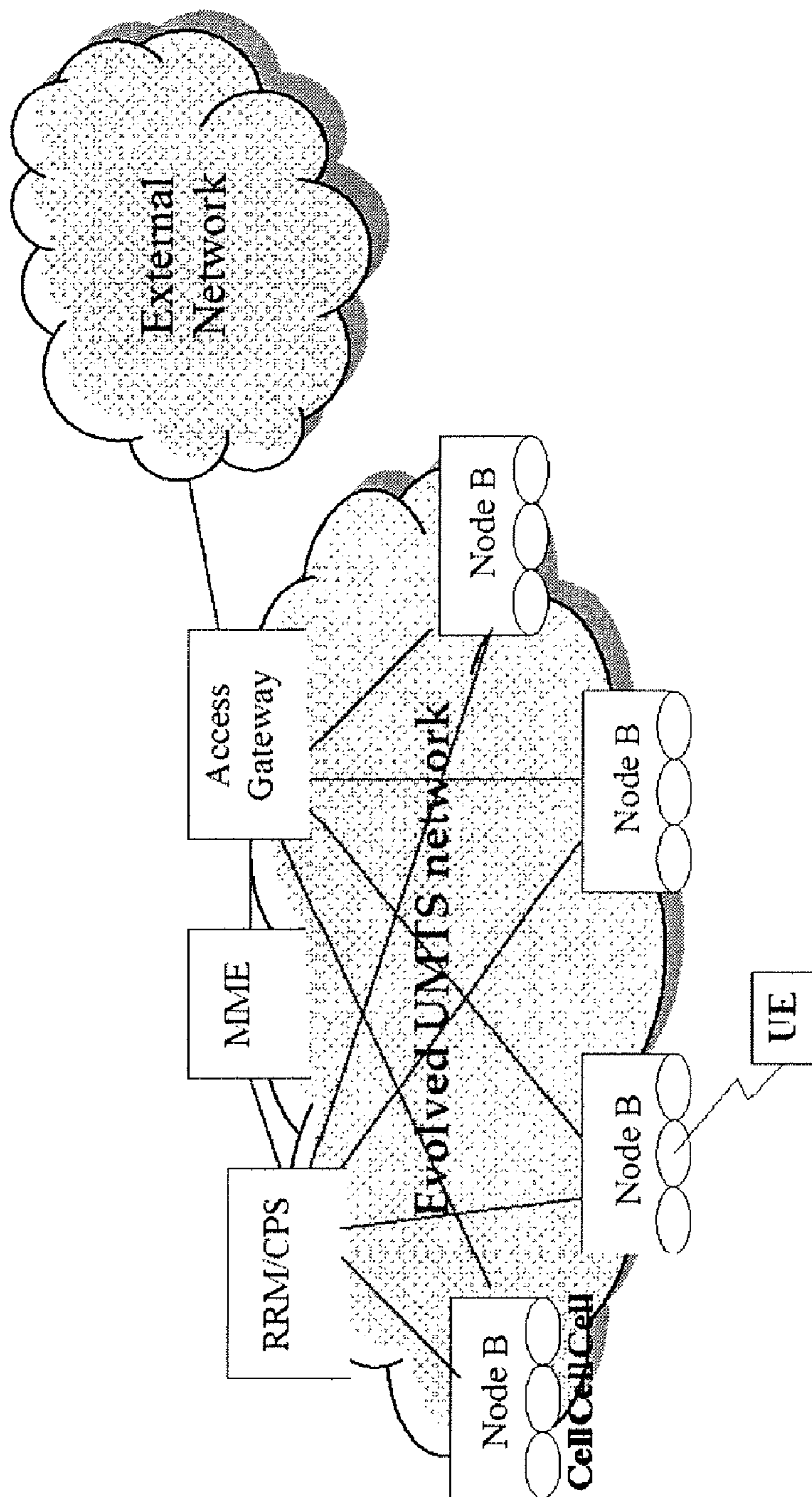

Fig 8

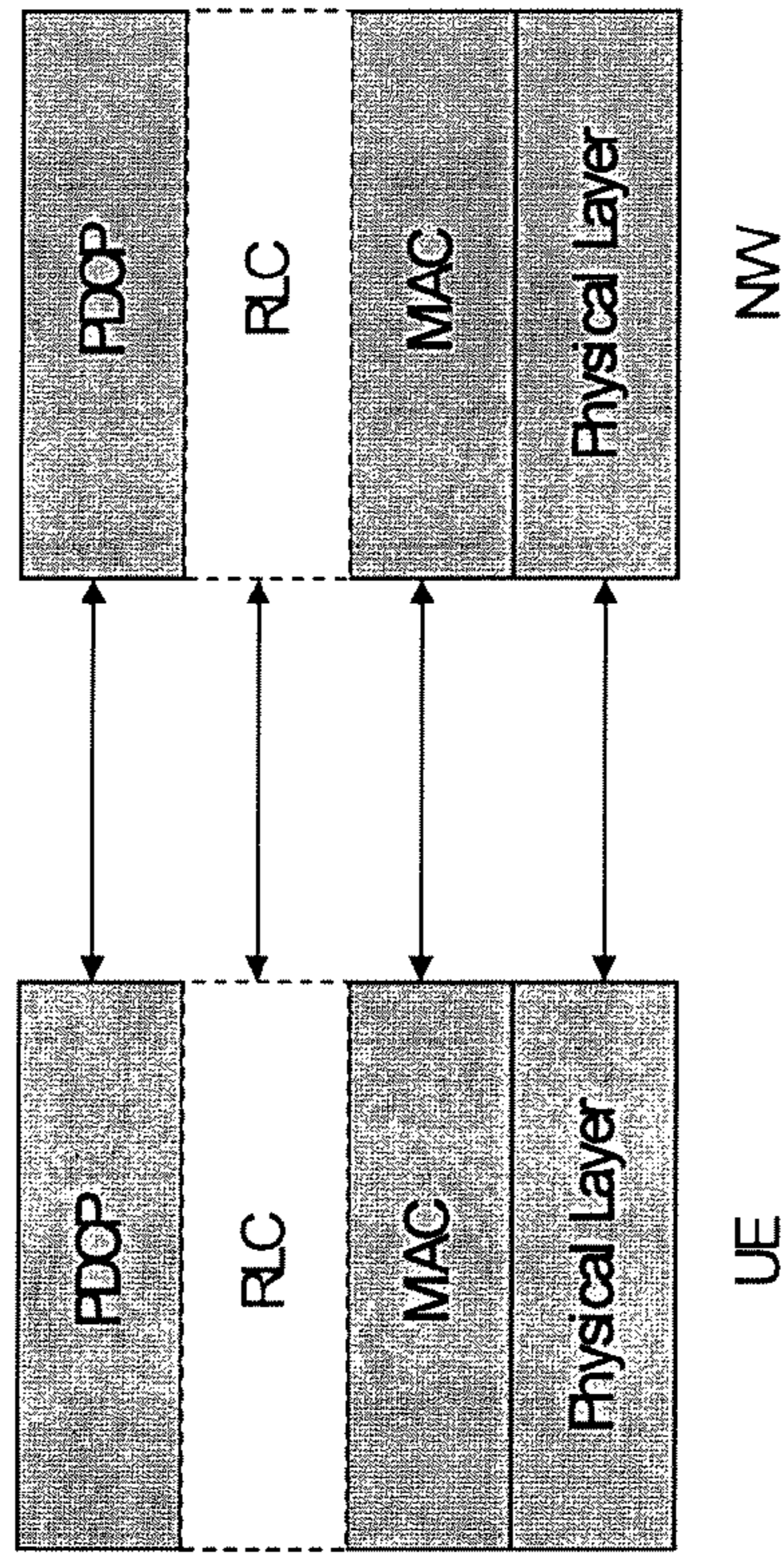

Fig 7

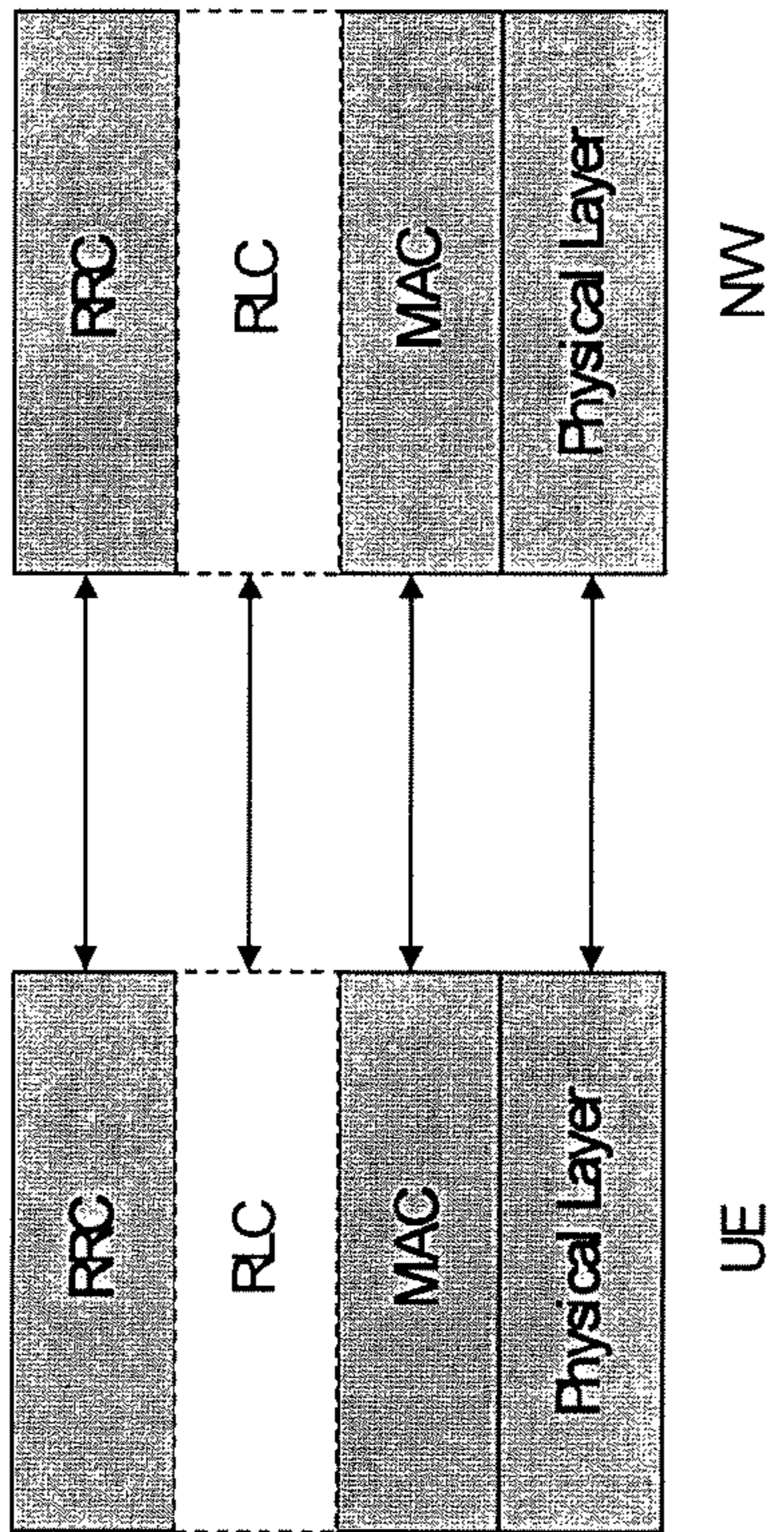
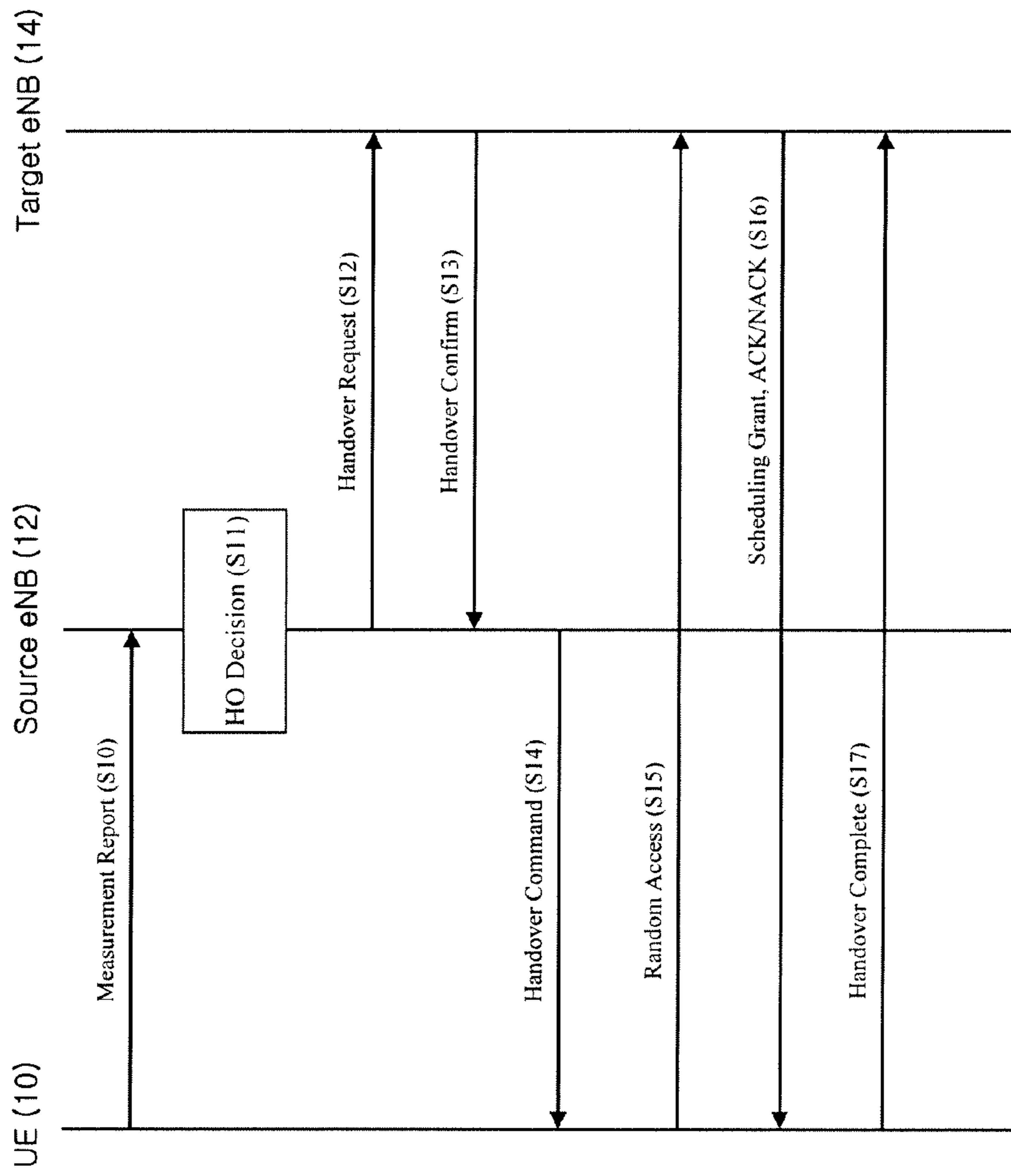

Fig 9



**METHOD OF TRANSMITTING AND
RECEIVING RADIO ACCESS
INFORMATION IN A WIRELESS MOBILE
COMMUNICATIONS SYSTEM**

Matter enclosed in heavy brackets [] appears in the original patent but forms no part of this reissue specification; matter printed in italics indicates the additions made by reissue; a claim printed with strikethrough indicates that the claim was canceled, disclaimed, or held invalid by a prior post-patent action or proceeding.

CROSS REFERENCE TO RELATED
APPLICATION

This application is a *continuation of U.S. application Ser. No. 14/676,490, filed Apr. 1, 2015, now U.S. Pat. No. RE46,602 and is a broadening reissue of U.S. application Ser. No. 13/487,081, filed Jun. 1, 2012, now U.S. Pat. No. 8,412,201. Said U.S. application Ser. No. 14/676,490 is a broadening reissue of U.S. application Ser. No. 13/487,081, filed Jun. 1, 2012, now U.S. Pat. No. 8,412,201, which is a continuation of U.S. Application Ser. No. 12/870,747, filed Aug. 27, 2010, now U.S. Pat. No. 8,219,097, which is a continuation of U.S. application Ser. No. 11/553,939, filed Oct. 27, 2006, now U.S. Pat. No. 7,809,373, which claims the benefit of earlier filing date and right of priority to U.S. Provisional Application No. 60/732,080, filed Oct. 31, 2005, and Korean Patent Application No. 10-2006-0063135, filed Jul. 5, 2006, the contents of which are all hereby incorporated by reference herein in their entirety.*

FIELD OF THE INVENTION

The present invention relates to wireless (radio) mobile communications systems, and in particular, relates to a method of transmitting and receiving radio connection information that allows a terminal to access a target base station (i.e., target eNB) in a faster and more efficient manner while performing a handover for the terminal to a cell of the target base station.

BACKGROUND ART

The universal mobile telecommunications system (UMTS) is a third-generation mobile communications system evolving from the global system for mobile communications system (GSM), which is the European standard. The UMTS is aimed at providing enhanced mobile communications services based on the GSM core network and wideband code-division multiple-access (W-CDMA) technologies.

FIG. 1 shows an exemplary diagram illustrating an Universal Mobile Telecommunication System (UMTS) network of a conventional mobile communication system. The UMTS is comprised of, largely, a user equipment (UE) or terminal, a UMTS Terrestrial Radio Access Network (UTRAN), and a core network (CN). The UTRAN comprises at least one Radio Network Sub-system (RNS), and each RNS is comprised of one Radio Network Controller (RNC) and at least one base station (Node B) which is controlled by the RNC. For each Node B, there is at least one cell.

FIG. 2 is an exemplary diagram illustrating a structure of a Radio interface Protocol (RIP) between a UE and the UTRAN. Here, the UE is associated with a 3rd Generation Partnership Project (3GPP) wireless access network stan-

ard. The structure of the RIP is comprised of a physical layer, a data link layer, and a network layer on the horizontal layers. On the vertical plane, the structure of the RIP is comprised of a user plane, which is used for transmitting data, and a control plane, which is used for transmitting control signals. The protocol layers of FIG. 2 can be categorized as L1 (first layer), L2 (second layer), and L3 (third layer) based on an Open System Interconnection (OSI) model. Each layer will be described in more detail as follows.

The first layer (L1), namely, the physical layer, provides an upper layer with an information transfer service using a physical channel. The physical layer is connected to an upper layer called a medium access control (MAC) layer through a transport channel. Data is transferred between the MAC layer and the physical layer through the transport channel. Data is also transferred between different physical layers, i.e. between physical layers of a transmitting side and a receiving side, through the physical channel.

The MAC layer of the second layer (L2) provides an upper layer called a radio link control (RLC) layer with a service through a logical channel. The RLC layer of the second layer supports reliable data transfer and performs segmentation and concatenation of a service data unit (SDU) received from an upper layer.

A radio resource control (RRC) layer at a lower portion of the L3 layer is defined in the control plane and controls logical channels, transport channels, and physical channels for configuration, re-configuration and release of radio bearers (RBs). A RB is a service provided by the second layer for data transfer between the terminal and the UTRAN. The configuration of the RBs includes defining characteristics of protocol layers and channels required to provide a specific service, and configuring respective specific parameters and operation methods.

A RRC connection and a signaling connection will be described in more detail as follows.

In order to perform communications, a terminal needs to have a RRC connection with the UTRAN and a signaling connection with the Core Network (CN). The terminal transmits and/or receives a terminal's control information with the UTRAN or the CN via the RRC connection and the signaling connection.

FIG. 3 shows an exemplary diagram for explaining how a RRC connection is established.

In FIG. 3, to establish the RRC connection, the terminal transmits a RRC Connection Request Message to the RNC, and then the RNC transmits a RRC Connection Setup Message to the terminal in response to the RRC Connection Request Message. After receiving the RRC Connection Setup Message by the terminal, the terminal transmits a RRC Connection Setup Complete Message to the RNC. If the above steps are successfully completed, the terminal establishes the RRC connection with the RNC. After the RRC connection is established, the terminal transmits an Initial Direct Transfer (IDT) message to the RNC for initializing a process of the signaling connection.

A Random Access Channel of a WCDMA will be described in more detail as follows.

The Random Access Channel (RACH) is used to transfer a short length data on an uplink, and some of the RRC message (i.e., RRC Connection Request Message, Cell Update Message, URA Update Message) is transmitted via the RACH. The RACH is mapped to a Common Control Channel (CCCH), a Dedicated Control Channel (DCCH) and a Dedicated Traffic Channel (DTCH), and then the RACH is mapped to a Physical Random Access Channel.

FIG. 4 shows how the physical random access channel (PRACH) power ramping and message transmission may be performed.

Referring to FIG. 4, the PRACH, which is an uplink physical channel, is divided into a preamble part and a message part. The preamble part is used to properly control a transmission power for a message transmission (i.e., a power ramping function) and is used to avoid a collision between multiple terminals. The message part is used to transmit a MAC PDU that was transferred from the MAC to the Physical channel.

When the MAC of the terminal instructs a PRACH transmission to the physical layer of the terminal, the physical layer of the terminal first selects one access slot and one (preamble) signature, and transmits the preamble on the PRACH to an uplink. Here, the preamble is transmitted within a particular the length of access slot duration (e.g., 1.33 ms). One signature is selected among the 16 different signatures within a first certain length of the access slot, and it is transmitted.

If the preamble is transmitted from the terminal, a base station transmits a response signal via an Acquisition indicator channel (AICH) which is a downlink physical channel. The AICH, in response to the preamble, transmits a signature that was selected within the first certain length of the access slot. Here, the base station transmits an ACK response or a NACK response to the terminal by means of the transmitted signature from the AICH.

If the ACK response is received, the terminal transmits a 10 ms or 20 ms length of the message part using an OVFSF code that correspond with the transmitted signature. If the NACK response is received, the MAC of the terminal instructs the PRACH transmission again to the physical layer of the terminal after a certain time period. Also, if no AICH is received with respect to the transmitted preamble, the terminal transmits a new preamble with a higher power compared to that used for the previous preamble after a predetermined access slot.

FIG. 5 illustrates an exemplary structure of an Acquisition Indicator Channel (AICH).

As shown in FIG. 5, the AICH, which is a downlink physical channel, transmits 16 symbol signatures (S_i , $i=0, \dots, 15$) for the access slot having a length of 5120 chips. The terminal may select any arbitrary signature (S_i) from S_0 signature to S_{15} signature, and then transmits the selected signature during the first 4096 chips length. The remaining 1024 chips length is set as a transmission power off period during which no symbol is transmitted. Also, as similar to FIG. 5, the preamble part of the uplink PRACH transmits 16 symbol signatures (S_i , $i=0, \dots, 15$) during the first 4096 chips length.

An Evolved Universal Mobile Telecommunication System (E-UMTS) will be described in more detail as follows.

FIG. 6 shows an exemplary structure of an Evolved Universal Mobile Telecommunications System (E-UMTS). The E-UMTS system is a system that has evolved from the UMTS system, and its standardization work is currently being performed by the 3GPP standards organization.

The E-UMTS network generally comprises at least one mobile terminal (i.e., user equipment: UE), base stations (i.e., Node Bs), a control plane server (CPS) that performs radio (wireless) control functions, a radio resource management (RRM) entity that performs radio resource management functions, a mobility management entity (MME) that performs mobility management functions for a mobile terminal, and an access gateway (AG) that is located at an end of the E-UMTS network and connects with one or more

external networks. Here, it can be understood that the particular names of the various network entities are not limited to those mentioned above.

The various layers of the radio interface protocol between the mobile terminal and the network may be divided into L1 (Layer 1), L2 (Layer 2), and L3 (Layer 3) based upon the lower three layers of the Open System Interconnection (OSI) standard model that is known the field of communication systems. Among these layers, a physical layer that is part of Layer 1 provides an information transfer service using a physical channel, while a Radio Resource Control (RRC) layer located in Layer 3 performs the function of controlling radio resources between the mobile terminal and the network. To do so, the RRC layer exchanges RRC messages between the mobile terminal and the network. The functions of the RRC layer may be distributed among and performed within the Node B, the CPS/RRM and/or the MME.

FIG. 7 shows an exemplary architecture of the radio interface protocol between the mobile terminal and the UTRAN (UMTS Terrestrial Radio Access Network). The radio interface protocol of FIG. 7 is horizontally comprised of a physical layer, a data link layer, and a network layer, and vertically comprised of a user plane for transmitting user data and a control plane for transferring control signaling. The radio interface protocol layer of FIG. 2 may be divided into L1 (Layer 1), L2 (Layer 2), and L3 (Layer 3) based upon the lower three layers of the Open System Interconnection (OSI) standards model that is known the field of communication systems.

Particular layers of the radio protocol control plane of FIG. 7 and of the radio protocol user plane of FIG. 8 will be described below. The physical layer (i.e., Layer 1) uses a physical channel to provide an information transfer service to a higher layer. The physical layer is connected with a medium access control (MAC) layer located thereabove via a transport channel, and data is transferred between the physical layer and the MAC layer via the transport channel. Also, between respectively different physical layers, namely, between the respective physical layers of the transmitting side (transmitter) and the receiving side (receiver), data is transferred via a physical channel.

The MAC layer of Layer 2 provides services to a radio link control (RLC) layer (which is a higher layer) via a logical channel. The RLC layer of Layer 2 supports the transmission of data with reliability. It should be noted that the RLC layer in FIG. 7 is depicted in dotted lines, because if the RLC functions are implemented in and performed by the MAC layer, the RLC layer itself may not need to exist. The PDCP layer of Layer 2 performs a header compression function that reduces unnecessary control information such that data being transmitted by employing Internet protocol (IP) packets, such as IPv4 or IPv6, can be efficiently sent over a radio (wireless) interface that has a relatively small bandwidth.

The radio resource control (RRC) layer located at the lowermost portion of Layer 3 is only defined in the control plane, and handles the control of logical channels, transport channels, and physical channels with respect to the configuration, re-configuration and release of radio bearers (RB). Here, the RB refers to a service that is provided by Layer 2 for data transfer between the mobile terminal and the UTRAN.

As for channels used in downlink transmission for transmitting data from the network to the mobile terminal, there is a broadcast channel (BCH) used for transmitting system information, and a shared channel (SCH) used for transmitting user traffic or control messages. Also, as a downlink

transport channel, there is a downlink Shared Control Channel (SCCH) that transmits necessary control information for the terminal to receive the downlink SCH. The downlink SCCH transmission includes information regarding a data variation, a data channel coding technique, and a data size where the data is transmitted to the downlink SCH.

As for channels used in uplink transmission for transmitting data from the mobile terminal to the network, there is a random access channel (RACH) used for transmitting an initial control message, and a shared channel (SCH) used for transmitting user traffic or control messages. Also, in an uplink transport channel, there is an uplink Shared Control Channel (SCCH) that transmits necessary control information for the terminal to receive the uplink SCH. The uplink SCCH transmission includes information regarding a data variation, a data channel coding technique, and a data size where the data is transmitted to the uplink SCH.

In the related art, when the mobile terminal moves from a source cell to a target cell, the mobile terminal uses a RACH to transmit a cell update message to the target cell. Namely, in order to transmit the cell update message, the terminal uses the RACH for an uplink time synchronization with the target cell and for an uplink resource allocation. However, due to a collision possibility of the RACH, the message transmission may be delayed, and a handover processing time is increased because of the possibility of RACH collision.

SUMMARY

The present invention has been developed in order to solve the above described problems of the related art. As a result, the present invention provides a method of transmitting and receiving control radio connection information that allows a faster and an efficient way of accessing a terminal to a target base station while performing a handover for the terminal to a cell of the target base station.

BRIEF DESCRIPTION OF THE DRAWINGS

FIG. 1 shows an exemplary diagram illustrating an Universal Mobile Telecommunication System (UMTS) network of a conventional mobile communication system.

FIG. 2 shows an exemplary diagram illustrating a structure of a Radio interface Protocol (RIP) between a UE and the UTRAN.

FIG. 3 shows an exemplary diagram for explaining how a RRC connection is established.

FIG. 4 shows how the physical random access channel (PRACH) power ramping and message transmission may be performed.

FIG. 5 illustrates an exemplary structure of an Acquisition Indicator Channel (AICH).

FIG. 6 shows an overview of an E-UMTS network architecture.

FIGS. 7 and 8 show an exemplary structure (architecture) of a radio interface protocol between a mobile terminal and a UTRAN according to the 3GPP radio access network standard.

FIG. 9 shows an exemplary diagram for transmitting and receiving radio connection information according to an exemplary embodiment of the present invention.

DESCRIPTION

One aspect of the present invention is the recognition by the present inventors regarding the problems and drawbacks

of the related art described above and explained in more detail hereafter. Based upon such recognition, the features of the present invention have been developed.

In the related art, when the mobile terminal moves from a source cell to a target cell, the mobile terminal uses a RACH to transmit a cell update message to the target cell. However, because of a possibility for a RACH collision (i.e. the same signature is being selected from multiple terminals that use of the RACH), the processing time for the handover process may be delayed.

In contrast, the features of the present invention provide that the terminal receives necessary information from a source cell in advance (i.e., before the terminal transmits a RACH setup request to a network) in order to utilize the RACH in a later step. As a result, the terminal can connect with the target cell with minimal delays.

It should be noted that the features of the present invention may be related to issues regarding the long-term evolution (LTE) of the 3GPP standard. As such, the 3GPP standard and its related sections or portions thereof, as well as various developing enhancements thereof pertain to the present invention. For example, in present invention, a source enhanced Node B (eNB) may manage the source cell described above and a target enhanced Node B (eNB) may manage the target cell.

FIG. 9 shows an exemplary diagram for transmitting and receiving radio connection information according to an exemplary embodiment of the present invention.

As illustrated in FIG. 9, the UE (or terminal) (10) may transmit a measurement report to the source eNB (12) by measuring a condition of a downlink physical channel for other cells periodically or upon the occurrence of event (i.e., user command, setting information, etc) (S10). As the measurement report is transmitted to the source eNB with a result for the measured condition of the downlink physical channel for other cells, the eNB may determine which cell, that the UE will be moved to, has a better channel condition compared to the current cell.

Using the measurement report which contains information about the condition of the downlink physical channel for other cells, the source eNB (12) may determine whether to perform a handover for the UE (10) from a current cell to the other cell, or whether to keep the UE in current cell (S11).

If the UE (10) needs to perform handover from the source eNB to an other particular cell, the source eNB (12) may transmit a handover request message to the target eNB (14) in order to request a handover for the UE to the target eNB. (S12) Here, the handover request message may include a UE identification (ID) and/or a buffer state of the UE.

If the target eNB (14) allows the handover to be performed for the UE upon receiving the handover request from the source eNB (12), the target eNB (14) may transmit a handover confirm message to the source eNB (12) (S13). The handover confirm message may include information that may be necessary in the course of connecting the UE (10) to the target cell. Namely, the necessary information may include information used in the RACH which is used for performing a radio access procedure from the UE to the target eNB. For example, when the RACH is being used while the UE accesses to the target eNB, the UE may utilize a preamble which is selected from signatures contained in the UE. System information transmitted from the eNB may include signatures related information. So, the UE may transmit the preamble to the eNB after selecting one of the signatures. However, in some cases, one or more UEs could select a same signature because there are a limited number

of signatures. Therefore, if two or more UEs transmit the preamble of the same signature to the eNB at the same time, the eNB can not possibly determine which UE transmitted such preamble. To avoid this from happening, the UE should not transmit a preamble that is selected from the signatures used in the RACH during the handover, but rather, the UE may transmit a preamble of a previously defined signature through the handover confirm message from the target eNB. Here, the target eNB may acknowledge the mapping relationship between an UE's ID and the signature, where the UE's ID is transmitted from the Handover Request Message. Therefore, when the UE transmits the preamble to the target eNB for establishing a radio connection to the target cell, the target eNB may determine an ID of the UE using the preamble. Also, the Handover Confirm message may include a transmission characteristic of the preamble that is transmitted from the UE (10) to the target eNB (14). The transmission characteristic may relate to frequency and time used in transmitting the preamble information.

If the source eNB (12) receives the Handover confirm message of the LIE from the target eNB (14), the source eNB (12) may transmit a Handover Command message to the UE (10). (S14) The Handover Command message may include necessary information which comes from the target eNB, for establishing the radio connection to the target eNB. Also, the Handover Command message may include information of the signature and the preamble which is to be used in the access procedure to the target eNB.

The UE (10), which received the handover command message from the source eNB (12), may utilize the RACH for establishing the radio connection between the UE and the target eNB. (S15) Here, the preamble transmission of the UE is based upon information in the handover command message received from the source eNB (12). Also, if the information includes system information of the target eNB (14), the UE (10) may perform a radio accessing procedure without reading broadcast system information from the target eNB (14). For example, when the UE performs to establish the radio connection with a new cell, the UE usually reads system information of the corresponding eNB after time synchronization of the downlink. Since the system information includes information related to a radio access request message from the UE to an uplink, the radio accessing is performed after reading the system information. However, according to the present invention, the UE (10) may perform the radio access procedure without reading the system information in the target cell, as the system information of the target eNB is previously transmitted to the source eNB in advance and the system information was included in the handover command message.

The target eNB (14) may receive the preamble of the UE. Since the target eNB (14) already allocates a signature used in the preamble to the UE in the use of handover, the UE can be identified by the preamble. The target eNB (14) may allocate the uplink radio resource to the UE (10) for the UE to access the target eNB and to transmit the handover complete message to the target eNB. (S16) Also, the allocated radio resources information may be transmitted to the UE (10) via a downlink SCH. Alternatively, the allocated radio resources information may be transmitted via a downlink SCCH. Further, the allocated radio resources may be transmitted within an ACK/NACK signaling.

The UE (10) may transmit the handover complete message to the target eNB (14) based on a scheduling grant of the target eNB. (S17) If the scheduling grant includes information of allocated radio resources upon an allocation request of the uplink radio resources of the UE, the sched-

uling grant may be transmitted with the ACK/NACK signaling of the preamble transmitted from the UE (10). In this case, the Handover complete message from the UE may include a buffer state of the UE or its related information. If the allocated uplink radio resources, which is transmitted from the target eNB (14) to the UE (10), is sufficient, the handover complete message may be transmitted with additional traffic data when there is additional uplink traffic data.

It can be said that the present invention provides a method of transmitting access information in a mobile communications system, the method comprising: deciding to perform a handover for a terminal to a cell of a target base station; transmitting, to the target base station, a handover request for performing a handover from a source base station to the target base station; receiving access information from the target base station that received the handover request, wherein the access information is then transmitted to the terminal to access the target base station; receiving a measurement report from the terminal; determining whether to perform a handover based upon the received measurement report; and transmitting a handover command that contains the access information to the terminal upon receiving the response by the source base station, wherein the measurement report includes a downlink physical channel condition for multiple cells including the cell of the target base station, the handover request includes at least one of terminal identification (ID) information and/or buffer state information of the terminal, the access information is random access information, the access information is for a random access channel (RACH), the access information includes at least one of signature information and/or preamble information, the signature information is determined by the target base station based upon terminal identification information, the preamble information includes frequency information and time information, and the handover command includes access information which contains at least one of signature information and/or preamble information to allow the terminal to access the target base station.

Also, the present invention may provide a method of transmitting access information in a mobile communications system, the method comprising: receiving, from a source base station, a handover request for performing a handover from the source base station to a target base station; transmitting access information to the source base station upon receiving the handover request, wherein the access information is used to allow a terminal to access the target base station; allocating a radio resource for an uplink and transmitting radio resource allocation information to the terminal; receiving, from the terminal, preamble information of the terminal; and receiving a handover complete message from the terminal, wherein the radio resource allocation information is transmitted to the terminal through at least one of a downlink shared channel (SCH) and a downlink shared control channel (SCCH), an ACK/NACK signal includes the allocated resource information, the preamble information is used to identify the terminal, the handover complete message includes at least one of buffer state information of the terminal and uplink traffic data, and the handover complete message includes uplink traffic data if the radio resource allocation for the uplink is sufficient to transmit the uplink traffic data.

It can be said that the present invention provides a method of receiving access information in mobile communications system, the method comprising: receiving access information from a source base station after a handover is accepted by a target base station; performing a random access procedure with the target base station using the received access

information; transmitting a measurement report to the source base station by measuring a condition of a downlink physical channel for other cells, the measuring performed periodically or upon an occurrence of an event; transmitting the preamble information to the target base station for performing a radio access procedure with the target cell; receiving, from a network, radio resource information through a downlink shared channel (SCCH); receiving, from a network, radio resource information within an ACK/NACK signaling; and transmitting a handover complete message to the target base station, wherein the measurement report is used to determine whether to perform a handover from a current cell to an other cell, the access information is random access information for a random access channel (RACH) which includes preamble information within signature information, the access information includes a transmission characteristic of the preamble information, the transmission characteristic relates to frequency and time used in transmitting the preamble information, the access information includes system information transmitted from the target base station, and the handover complete message includes at least one of buffer state information of the terminal and uplink traffic data.

The present invention also may provide a mobile terminal for establishing a radio connection to a target base station in a mobile communications system, the mobile terminal comprising: a radio protocol adapted to receive access information from a source base station after a handover is accepted by the target base station and to perform a random access procedure with the target base station using the received access information, wherein the source base station is a source enhanced Node B (source eNB) and the target base station is a target enhanced Node B (target eNB) respectively in an Evolved Universal Mobile Telecommunication System (E-UMTS).

Although the present invention is described in the context of mobile communications, the present invention may also be used in any wireless communication systems using mobile devices, such as PDAs and laptop computers equipped with wireless communication capabilities (i.e. interface). Moreover, the use of certain terms to describe the present invention should not limit the scope of the present invention to a certain type of wireless communication system. the present invention is also applicable to other wireless communication systems using different air interfaces and/or physical layers, for example, TDMA, CDMA, FDMA, WCDMA, OFDM, EVDO, Mobile Wi-Max, Wi-Bro, etc.

The preferred embodiments may be implemented as a method, apparatus or article of manufacture using standard programming and/or engineering techniques to produce software, firmware, hardware, or any combination thereof. The term "article of manufacture" as used herein refers to code or logic implemented in hardware logic (e.g., an integrated circuit chip, Field Programmable Gate Array (FPGA), Application Specific Integrated Circuit (ASIC), etc.) or a computer readable medium (e.g., magnetic storage medium (e.g., hard disk drives, floppy disks, tape, etc.), optical storage (CDROMs, optical disks, etc.), volatile and non-volatile memory devices (e.g., EEPROMs, ROMs, PROMs, RAMs, DRAMs, SRAMs, firmware, programmable logic, etc).

Code in the computer readable medium is accessed and executed by a processor. The code in which preferred embodiments are implemented may further be accessible through a transmission media or from a file server over a network. In such cases, the article of manufacture in which the code is implemented may comprise a transmission

media, such as a network transmission line, wireless transmission media, signals propagating through space, radio waves, infrared signals, etc. Of course, those skilled in the art will recognize that many modifications may be made to this configuration without departing from the scope of the present invention, and that the article of manufacture may comprise any information bearing medium known in the art.

This specification describes various illustrative embodiments of the present invention. The scope of the claims is intended to cover various modifications and equivalent arrangements of the illustrative embodiments disclosed in the specification. Therefore, the following claims should be accorded the reasonably broadest interpretation to cover modifications, equivalent structures, and features that are consistent with the spirit and scope of the invention disclosed herein.

What is claimed is:

[1. A method of performing a random access procedure in a mobile communications system, the method comprising: receiving, by a terminal, a handover command message from a source base station, wherein the handover command message includes preamble information for the random access procedure, wherein the preamble information is a specific preamble used only for a specific terminal, and wherein the specific preamble is determined by a target base station; and performing, by the terminal, the random access procedure with the target base station using the specific preamble.]

[2. The method of claim 1, wherein the handover command message is generated by the target base station.]

[3. The method of claim 1, wherein the handover command message is transferred by the source base station to the specific terminal.]

[4. The method of claim 1, further comprising: transmitting, by the terminal, a measurement report to the source base station by measuring a condition of a downlink physical channel for other cells periodically or upon an occurrence of an event.]

[5. The method of claim 4, wherein the measurement report is used to determine whether to perform a handover from a current cell to the other cell.]

[6. The method of claim 1, wherein the preamble information includes frequency information and time information.]

[7. A method of performing a random access procedure in a mobile communications system, the method comprising: receiving, by a source base station, a handover command message from a target base station, wherein the handover command message includes preamble information for the random access procedure, wherein the preamble information is a specific preamble used only for a specific terminal, and wherein the specific preamble is determined by a target base station; and transferring, by the source base station, the received handover command message to the specific terminal, wherein the specific preamble is used to perform the random access procedure.]

[8. The method of claim 7, wherein the handover command message is generated by the target base station.]

[9. The method of claim 7, wherein the preamble information includes frequency information and time information.]

11

[10. A method of performing a random access procedure in a mobile communications system, the method comprising:

generating, by a target base station, a handover command message,

wherein the handover command message includes preamble information for the random access procedure, wherein the preamble information is a specific preamble used only for a specific terminal; and

transmitting, by the target base station, the handover command message to a source base station,

wherein the handover command message is transferred by a source base station to the specific terminal, wherein the specific preamble is used to perform the random access procedure.]

[11. The method of claim 10, wherein the preamble information includes frequency information and time information.]

[12. A mobile terminal that performs a random access procedure in a mobile communications system, the mobile terminal comprising:

a radio protocol adapted to receive the handover command message from a source base station, and to perform the random access procedure with a target base station, wherein the handover command message includes preamble information for the random access procedure, wherein the preamble information is a specific preamble used only for a specific terminal, wherein the specific preamble is determined by a target base station, wherein the specific preamble is used to perform the random access procedure.]

[13. The terminal of claim 12, wherein the source base station and the target base station are a source enhanced Node B (source eNB) and a target enhanced Node B (target eNB) respectively in an Evolved Universal Mobile Telecommunication System (E-UMTS).]

14. A method to perform a random access procedure in a mobile communications system comprising:

receiving, by a terminal, a handover command message from a source base station which has determined that a handover should occur to a target base station, wherein the handover command message includes information related to a preamble for the terminal previously defined in a handover confirm message sent from the target base station to the source base station;

in response to the handover command message, performing, by the terminal, a random access procedure with the target base station to connect with the target base station using the information related to the preamble; and

12

transmitting, by the terminal, a handover complete message to the target base station.

15. The method of claim 14, wherein the handover command message includes time and frequency information to connect the target base station and the terminal.

16. The method of claim 14, further comprising receiving, in the terminal, time and frequency information from the source base station for use in connecting to the target base station.

17. The method of claim 14, wherein performing the random access procedure with the target base station using the information related to the preamble comprises transmitting, by the terminal to the target base station, a preamble sequence in accordance with the information related to the preamble.

18. A mobile terminal to transmit uplink data in a wireless communication system, the mobile terminal comprising:

a transceiver configured to transmit the uplink data;

a memory configured to store the uplink data; and

a processor cooperating with the transceiver and the memory, the processor configured to:

receive a handover command message from a source base station which has determined that a handover should occur to a target base station;

wherein the handover command message includes information related to a preamble for the terminal previously defined in a handover confirm message sent from the target base station to the source base station;

in response to the handover command message, perform, by the terminal, a random access procedure with the target base station to connect with the target base station using the information related to the preamble; and

transmit a handover complete message to the target base station.

19. The mobile terminal of claim 18, wherein the handover command message includes time and frequency information to connect the target base station and the terminal.

20. The mobile terminal of claim 18, wherein the processor is further configured to receive, in the terminal, time and frequency information from the source base station for use in connecting to the target base station.

21. The mobile terminal of claim 18, wherein the processor is further configured to perform the random access procedure with the target base station using the information related to the preamble comprises transmitting, by the terminal to the target base station, a preamble sequence in accordance with the information related to the preamble.

* * * * *