



US00RE48218E

(19) **United States**  
(12) **Reissued Patent**  
**McAuliffe**

(10) **Patent Number: US RE48,218 E**  
(45) **Date of Reissued Patent: \*Sep. 22, 2020**

(54) **SYSTEM AND METHOD FOR MAINTAINING A MINIMUM SEPARATION BETWEEN PALLETS POSITIONED ON ADJACENT RACKS**

(71) Applicant: **Kevin McAuliffe**, Indian Trail, NC (US)

(72) Inventor: **Kevin McAuliffe**, Indian Trail, NC (US)

(\*) Notice: This patent is subject to a terminal disclaimer.

(21) Appl. No.: **16/297,917**

(22) Filed: **Mar. 11, 2019**

**Related U.S. Patent Documents**

Reissue of:

(64) Patent No.: **9,604,784**  
Issued: **Mar. 28, 2017**  
Appl. No.: **14/993,167**  
Filed: **Jan. 12, 2016**

U.S. Applications:

(63) Continuation-in-part of application No. 14/324,840, filed on Jul. 7, 2014, now Pat. No. 9,604,783.

(60) Provisional application No. 61/843,538, filed on Jul. 8, 2013.

(51) **Int. Cl.**  
**B65G 1/14** (2006.01)  
**B65G 1/02** (2006.01)

(52) **U.S. Cl.**  
CPC ..... **B65G 1/14** (2013.01); **B65G 1/02** (2013.01)

(58) **Field of Classification Search**  
CPC ..... B65G 1/14; B65D 19/40; A47B 47/021  
USPC ... 108/55.1, 57.16, 57.17, 57.2, 57.3, 57.33; 211/183, 191

See application file for complete search history.

(56) **References Cited**

**U.S. PATENT DOCUMENTS**

1,830,998	A *	11/1931	Harbord .....	B65D 19/0097	294/67.4
3,802,574	A	4/1974	Weider		
4,757,967	A *	7/1988	Delmore .....	E04B 2/7453	248/218.4
5,209,444	A *	5/1993	Rinderer .....	H02G 3/126	248/205.1
5,584,624	A	12/1996	DeVoursney		
5,664,688	A	9/1997	Kitanaka et al.		
6,173,846	B1	1/2001	Anderson		
7,255,315	B2 *	8/2007	Oh .....	A62C 35/68	169/43
7,578,101	B2 *	8/2009	Ganske .....	E04F 21/185	248/544
7,784,413	B2	8/2010	Gabriel et al.		
9,004,422	B2 *	4/2015	Feenstra .....	A62C 35/68	248/200.1

(Continued)

*Primary Examiner* — Cary E Wehner

(74) *Attorney, Agent, or Firm* — Hammer & Associates, P.C.

(57) **ABSTRACT**

A system for maintaining a minimum separation between pallets positioned on racks. The system comprising a double back stop. The stop includes: a first and a second back stop configured to prevent lateral movement of the pallets beyond the back stops, the back stops defining a minimum separation between the pallets; and a middle section connecting the back stops includes a vertical cross-member; and one or more of the following: a clip forming a channel affixed to the double back stop, and/or a web affixed to the double back stop, and/or a member affixed to the double back stop, and/or a slot in the double back stop.

**7 Claims, 7 Drawing Sheets**

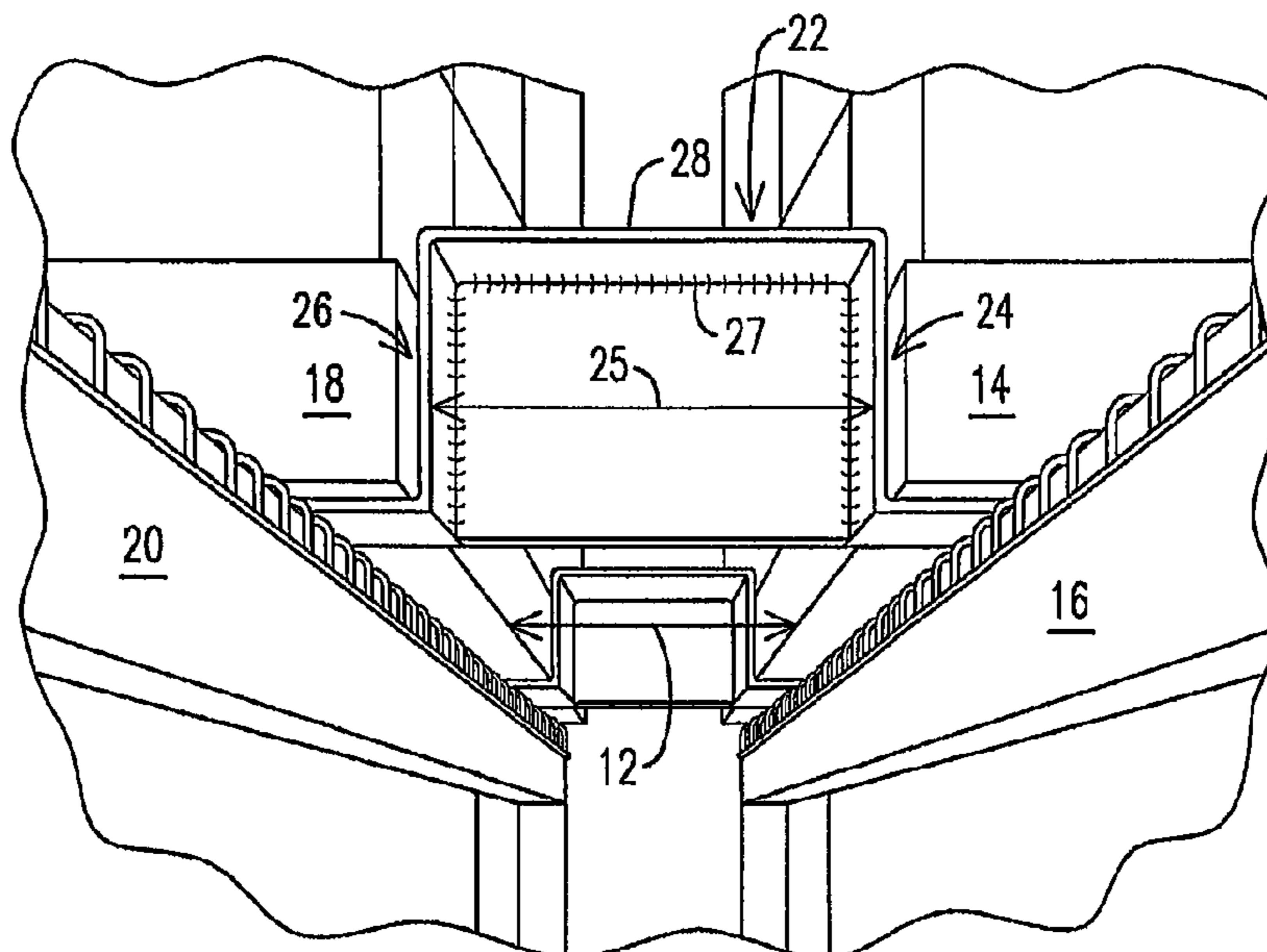

(56)

**References Cited**

U.S. PATENT DOCUMENTS

2007/0175371 A1\* 8/2007 Wyatt ..... A47B 47/027  
110/325  
2009/0084746 A1 4/2009 Rioux  
2010/0078399 A1 4/2010 Higueroa et al.  
2010/0219146 A1 9/2010 Hamby et al.  
2012/0067838 A1 3/2012 Lawson et al.  
2013/0105428 A1 5/2013 Yaniak et al.  
2015/0014262 A1\* 1/2015 McAuliffe ..... B65G 1/02  
211/71.01  
2018/0242738 A1\* 8/2018 Willix ..... A47B 96/00  
2019/0110612 A1\* 4/2019 Iellimo ..... B65G 1/02

\* cited by examiner

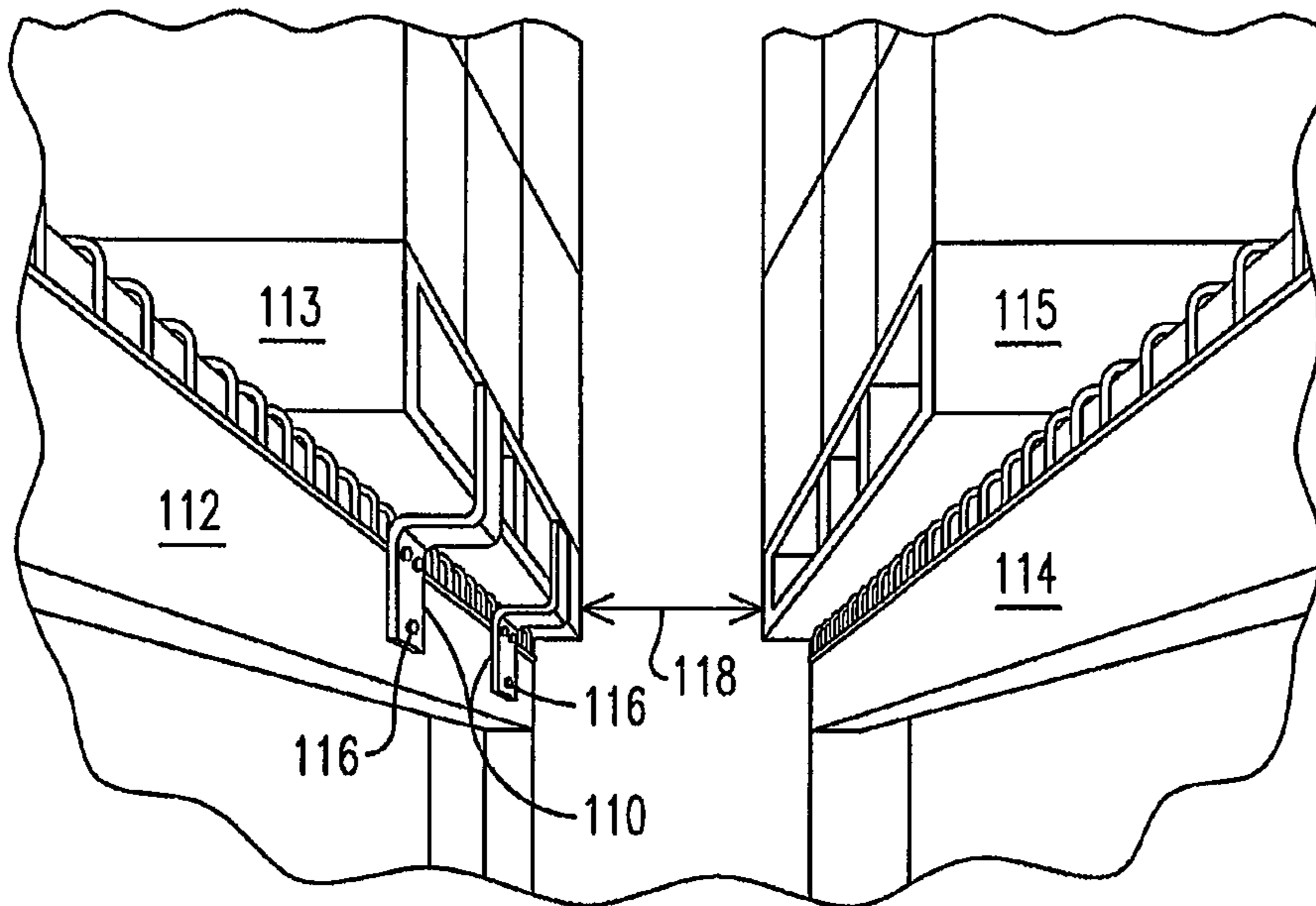

FIG. 1  
Prior Art

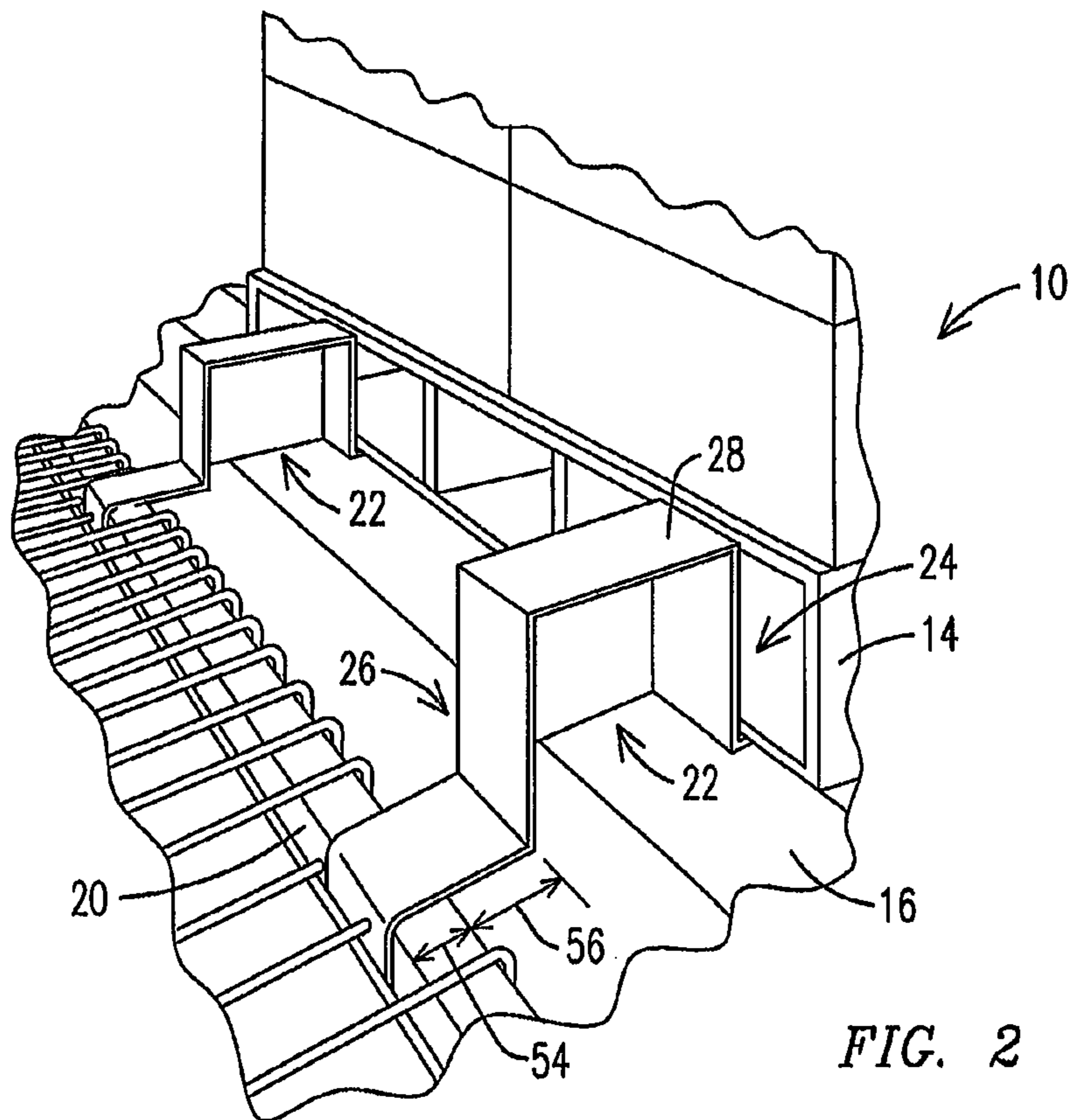

FIG. 2

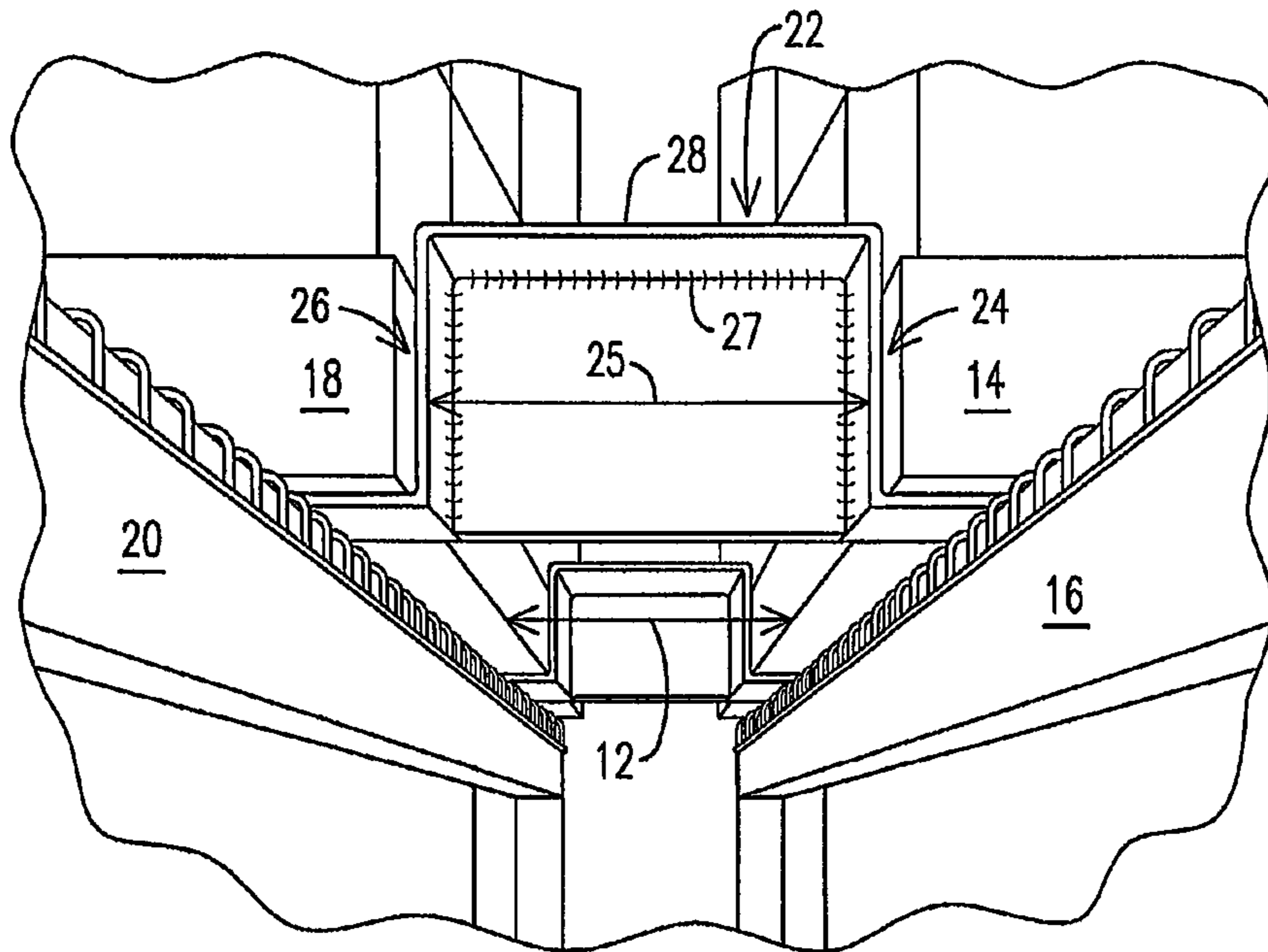

FIG. 3

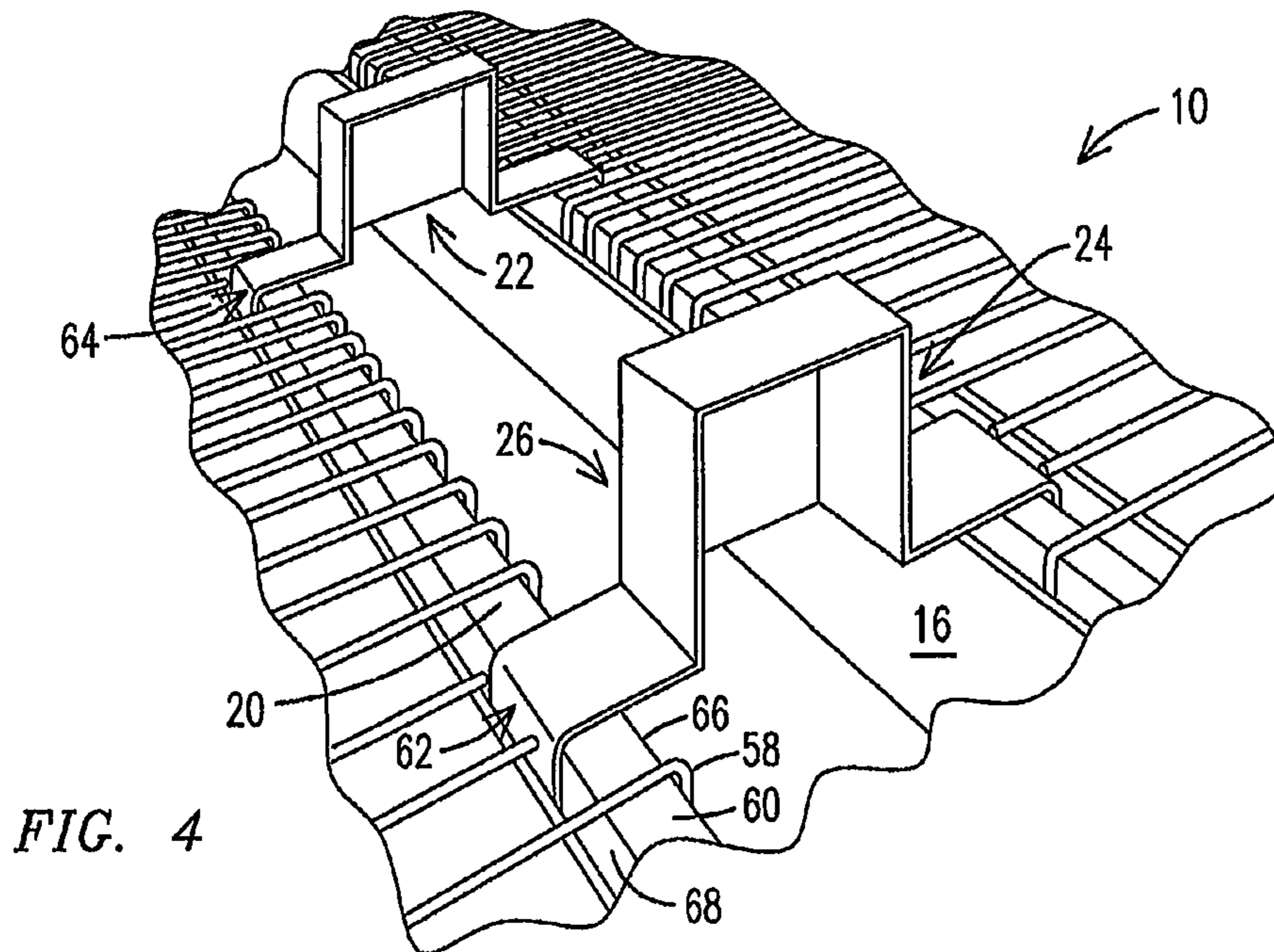

FIG. 4



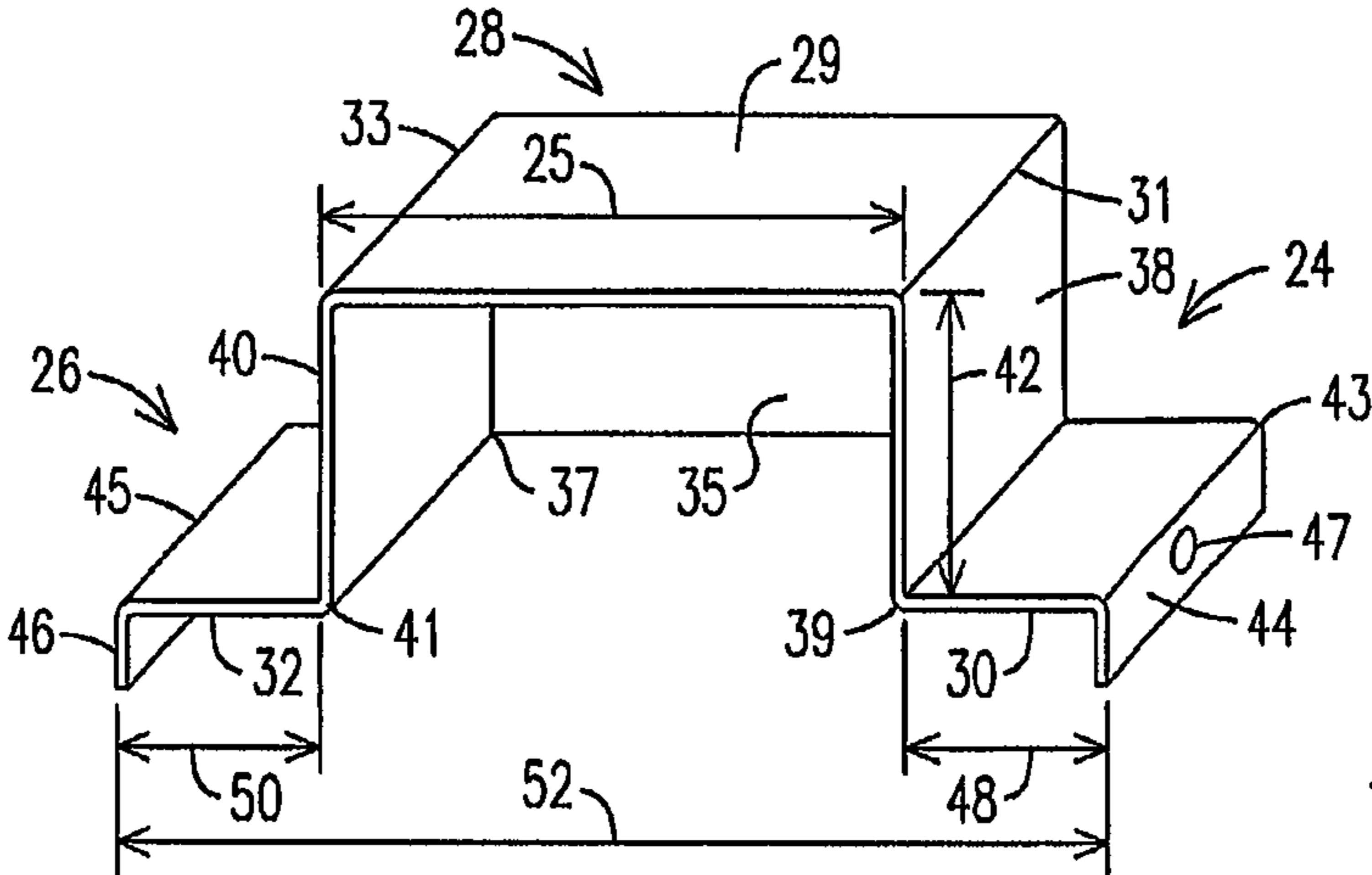

FIG. 5

FIG. 6

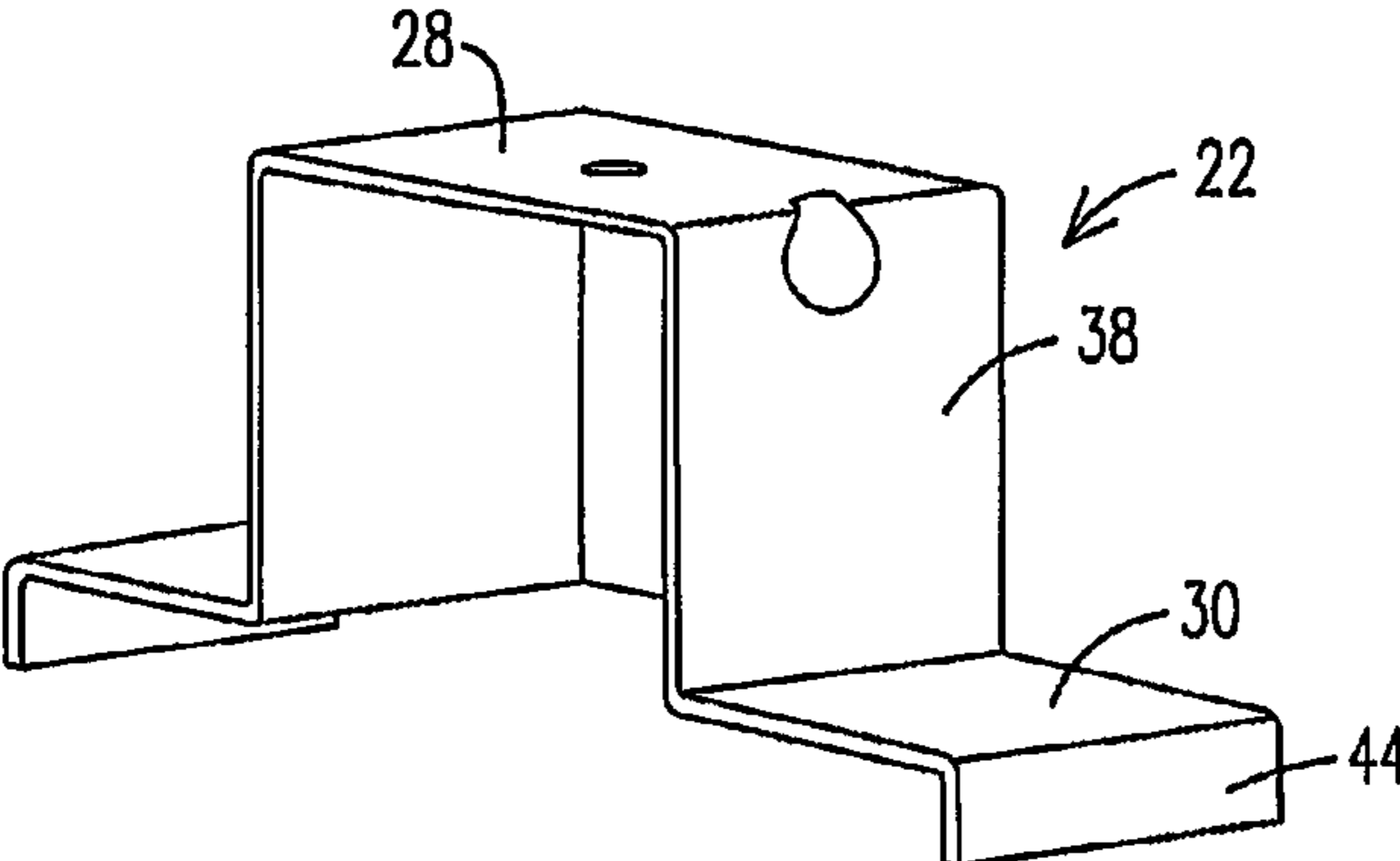
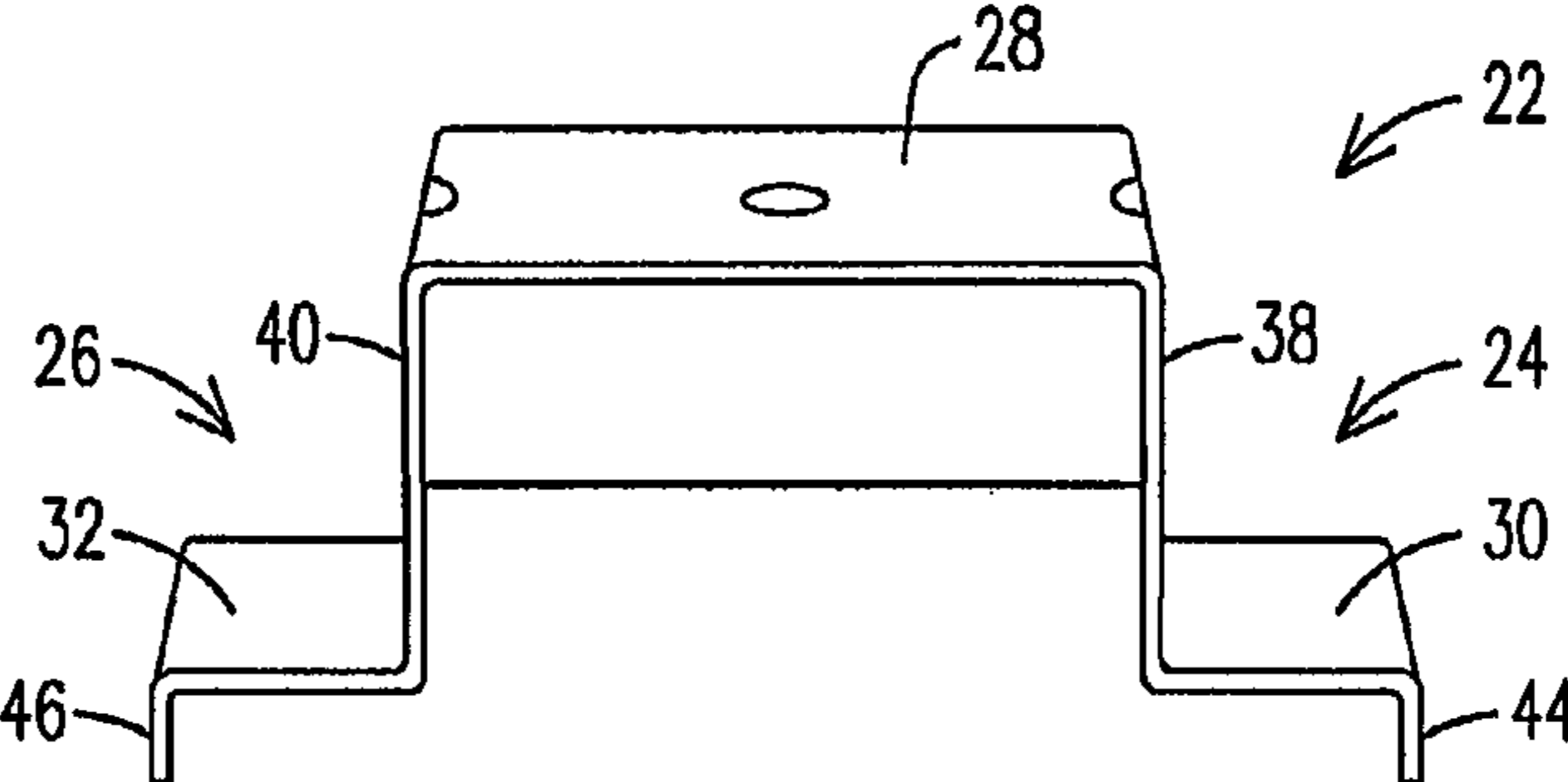
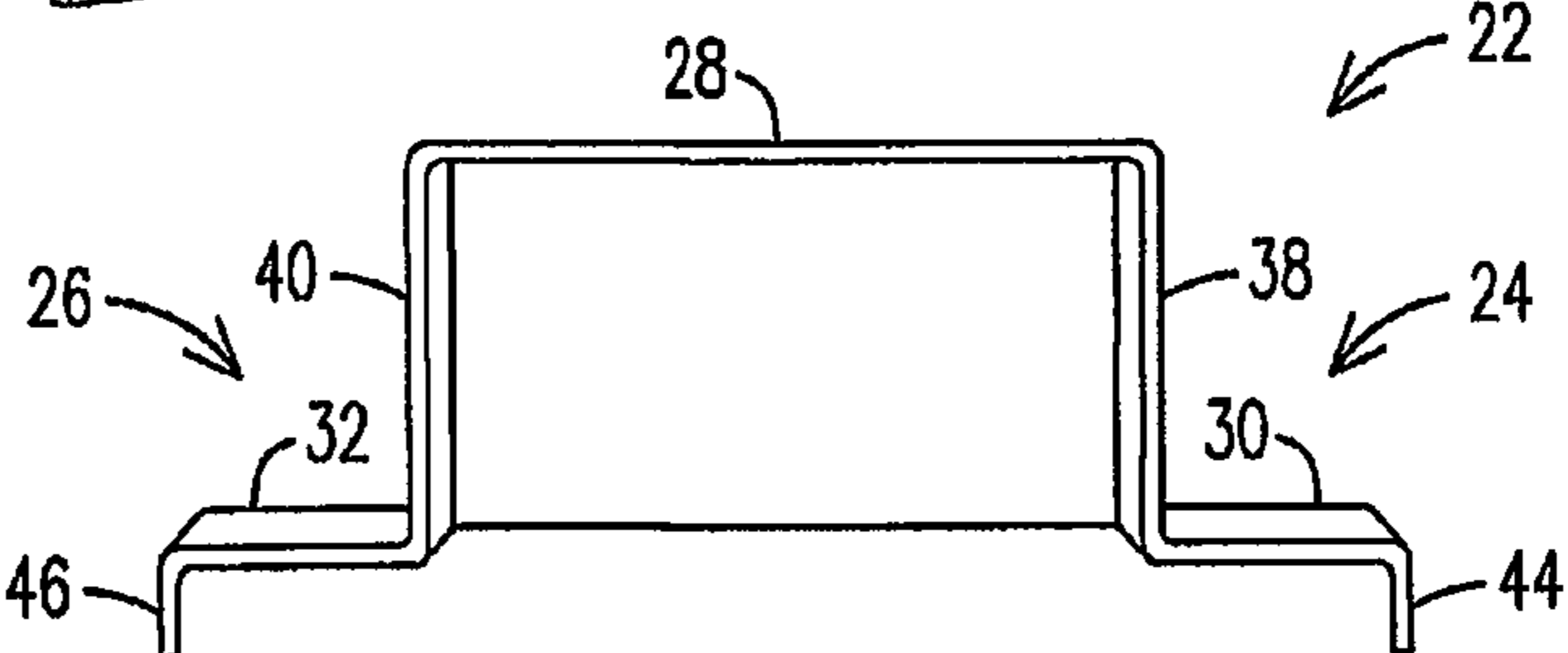

FIG. 7

FIG. 8



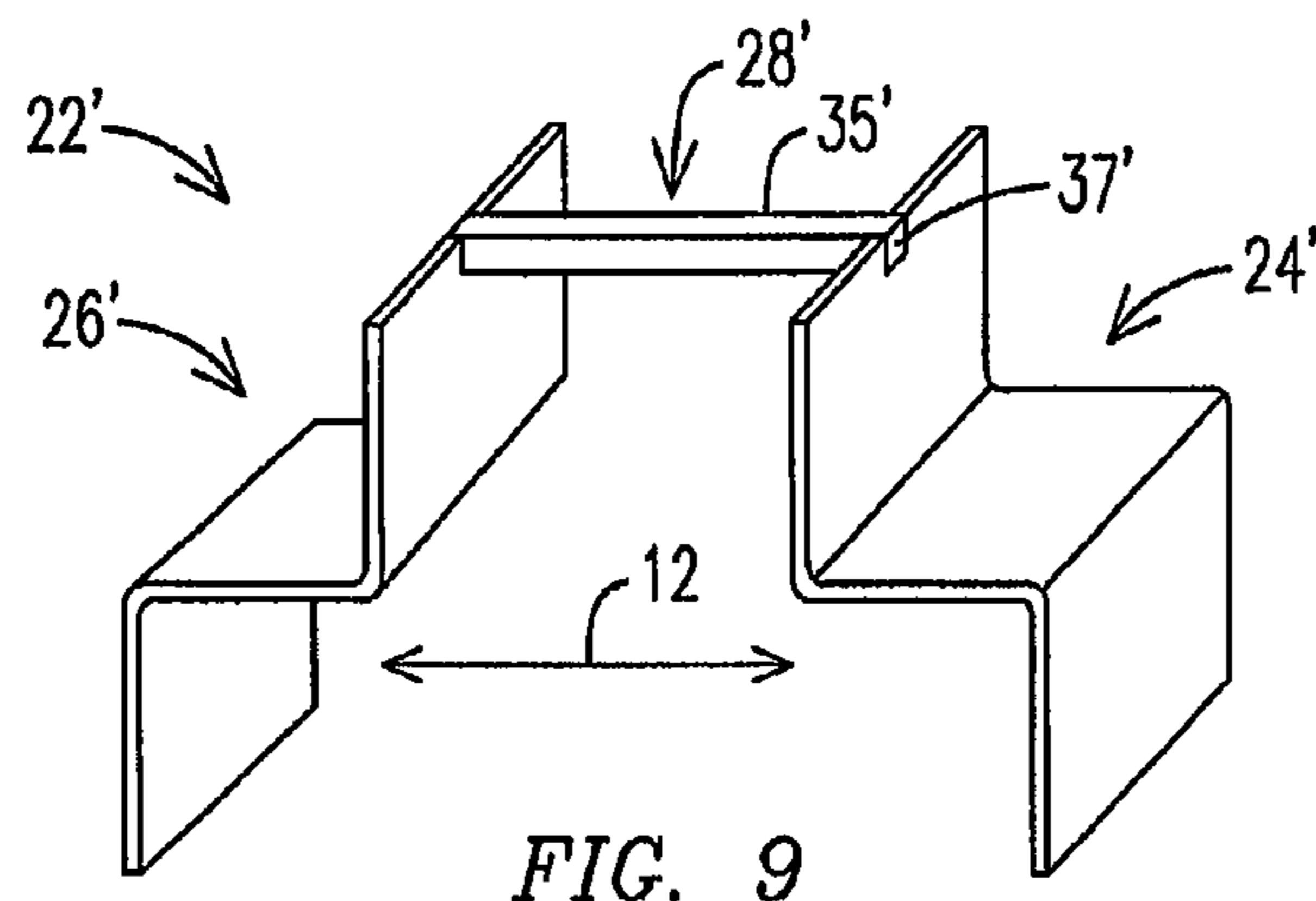

FIG. 9

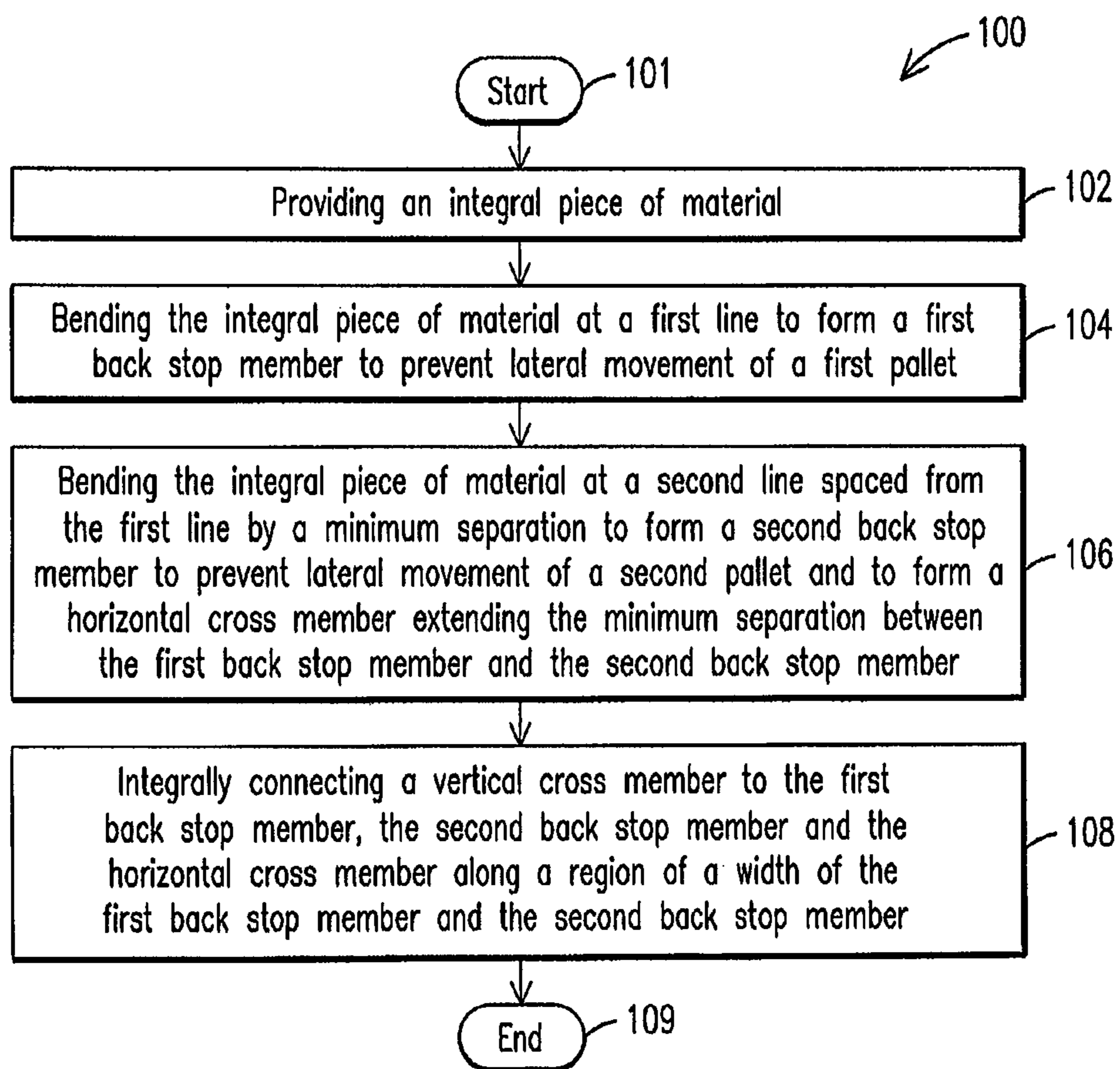

FIG. 10

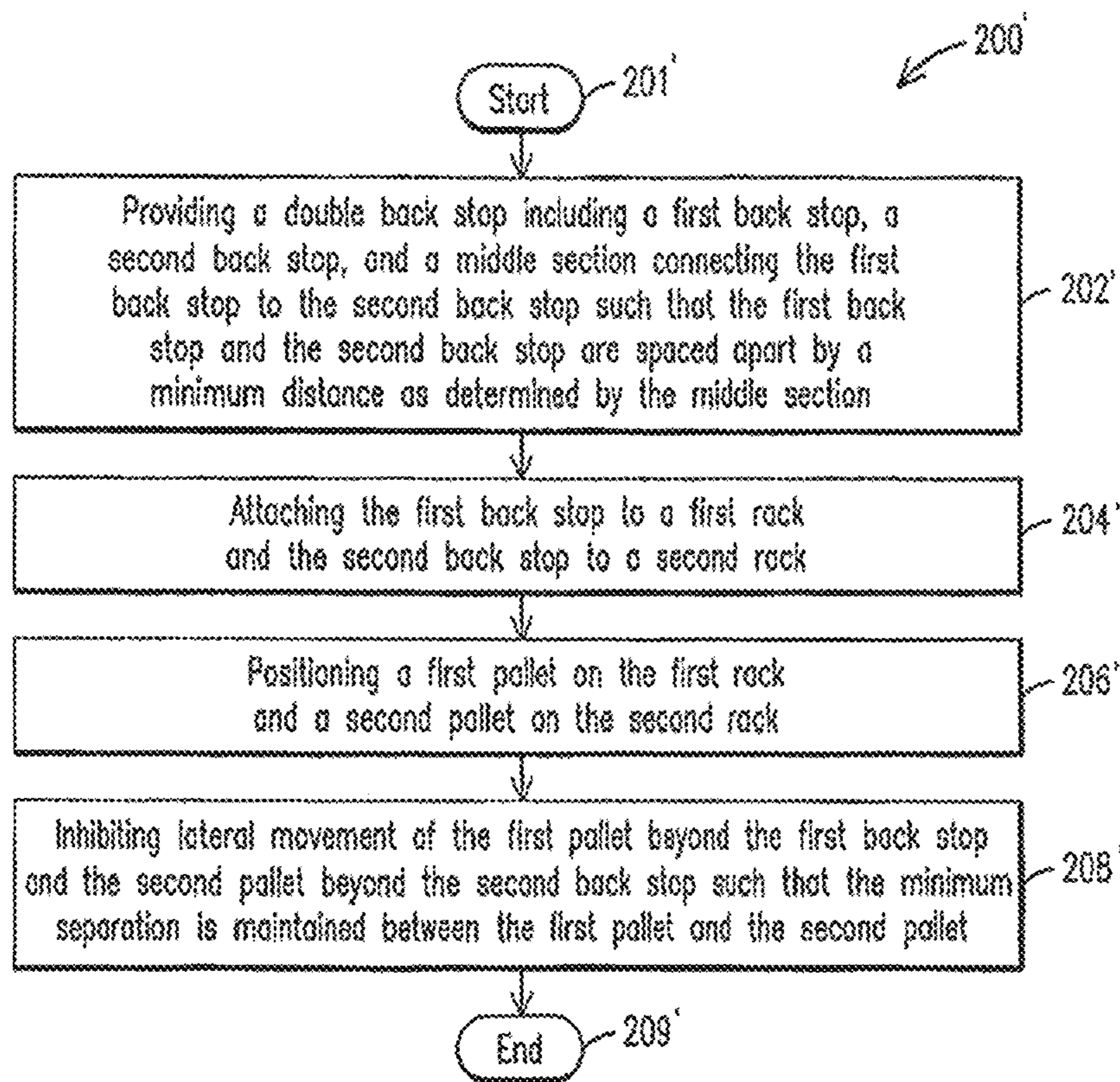

FIG. 11

AMENDED

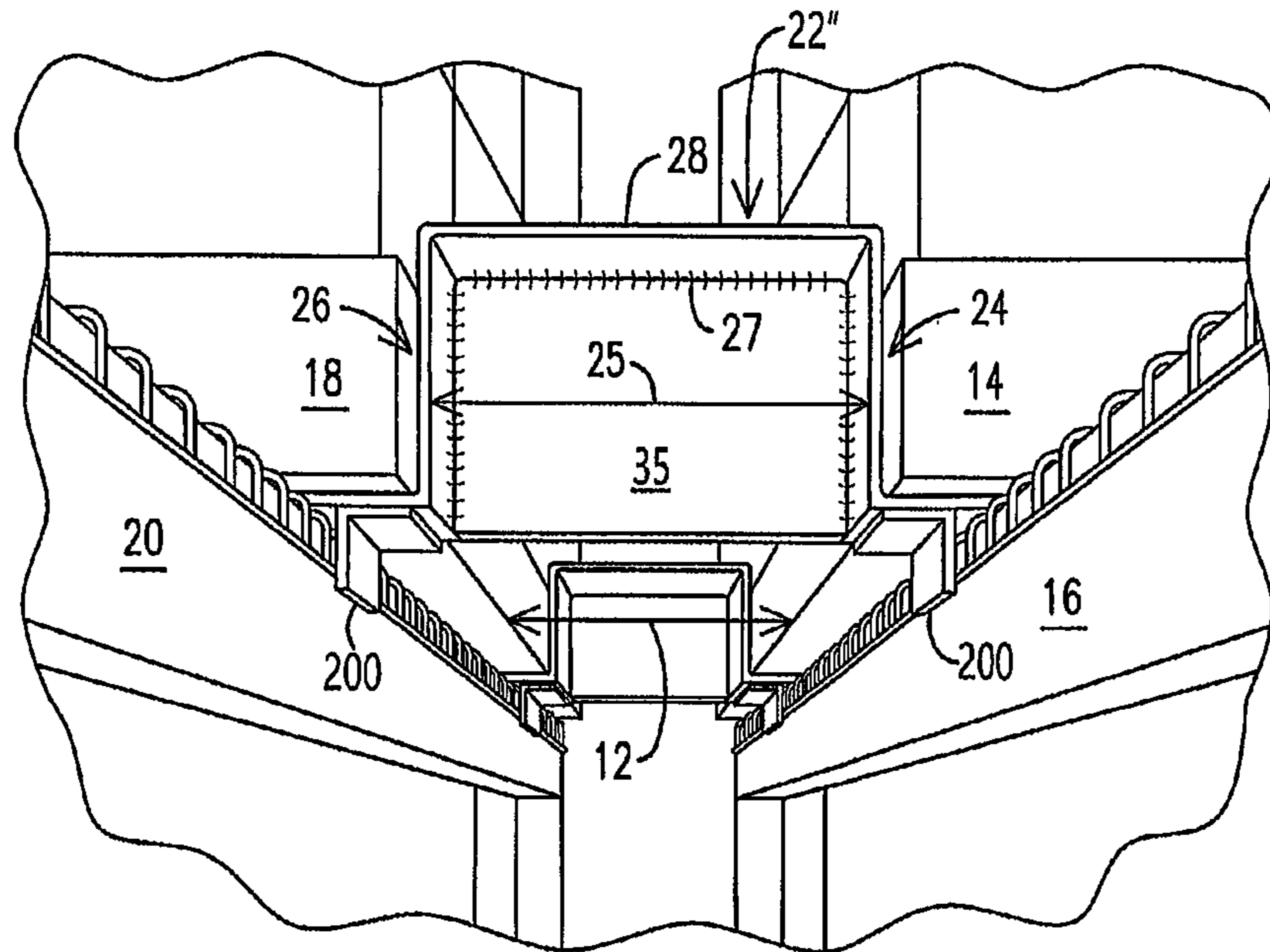

FIG. 12

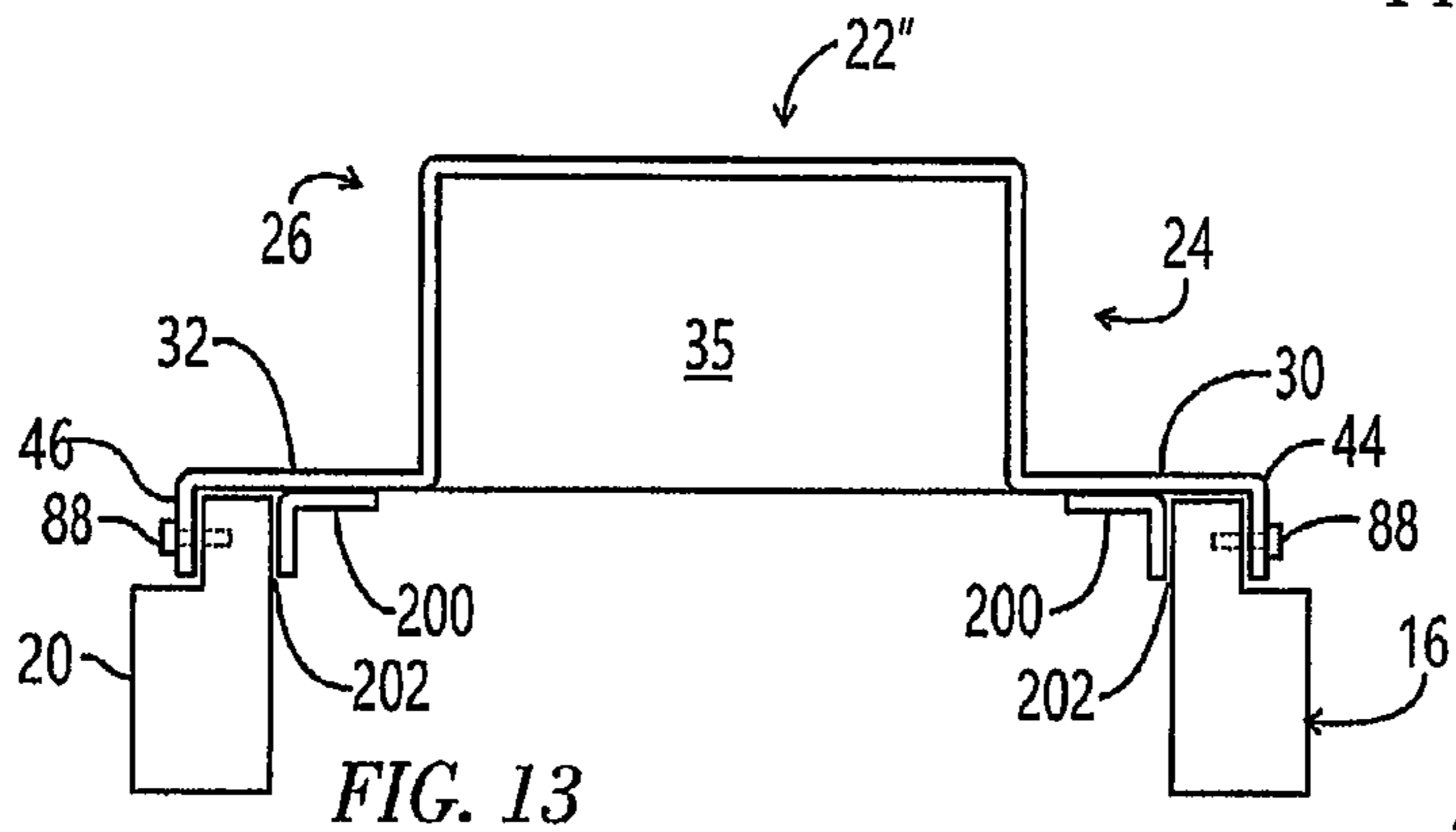

FIG. 13

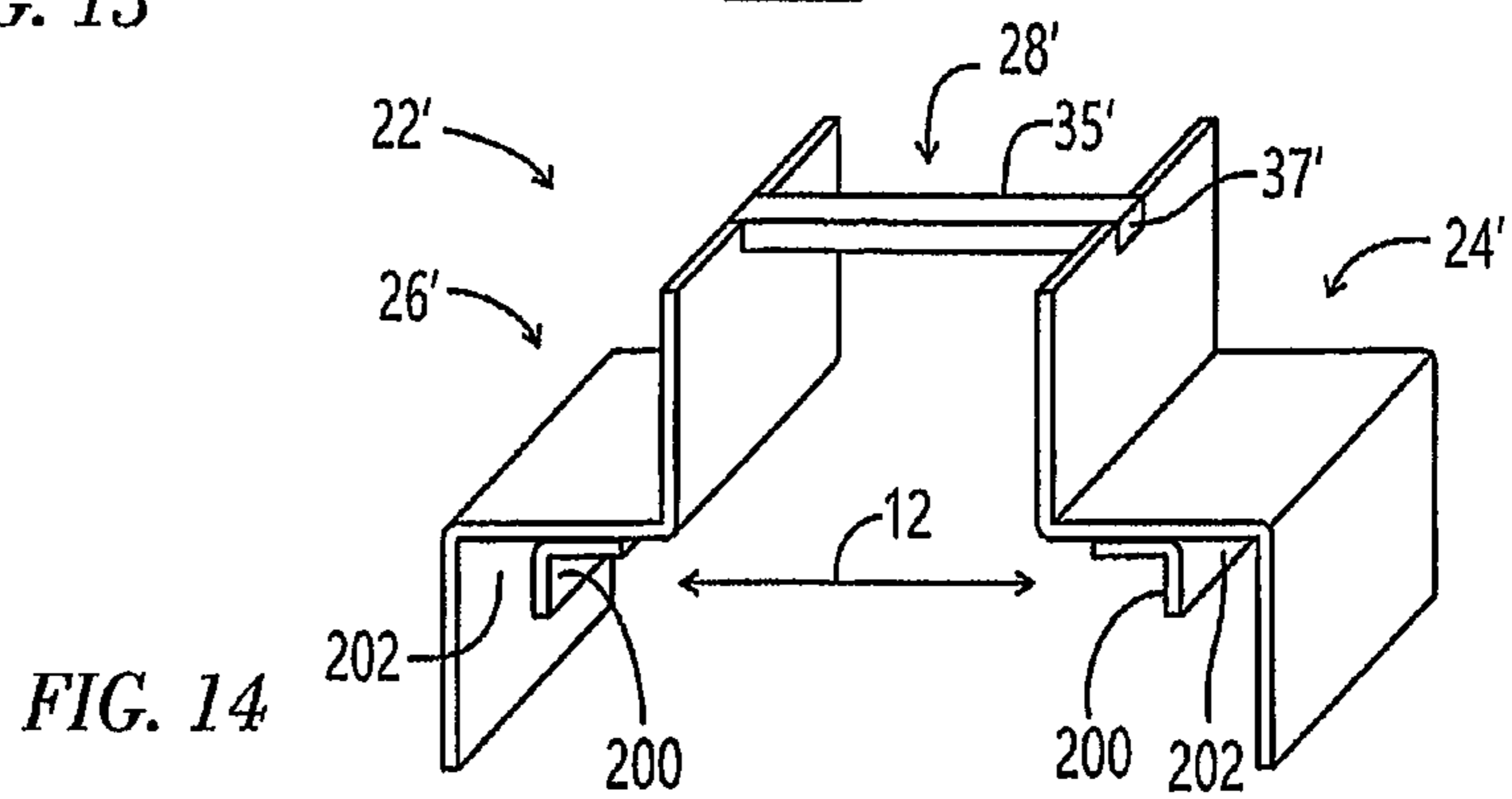
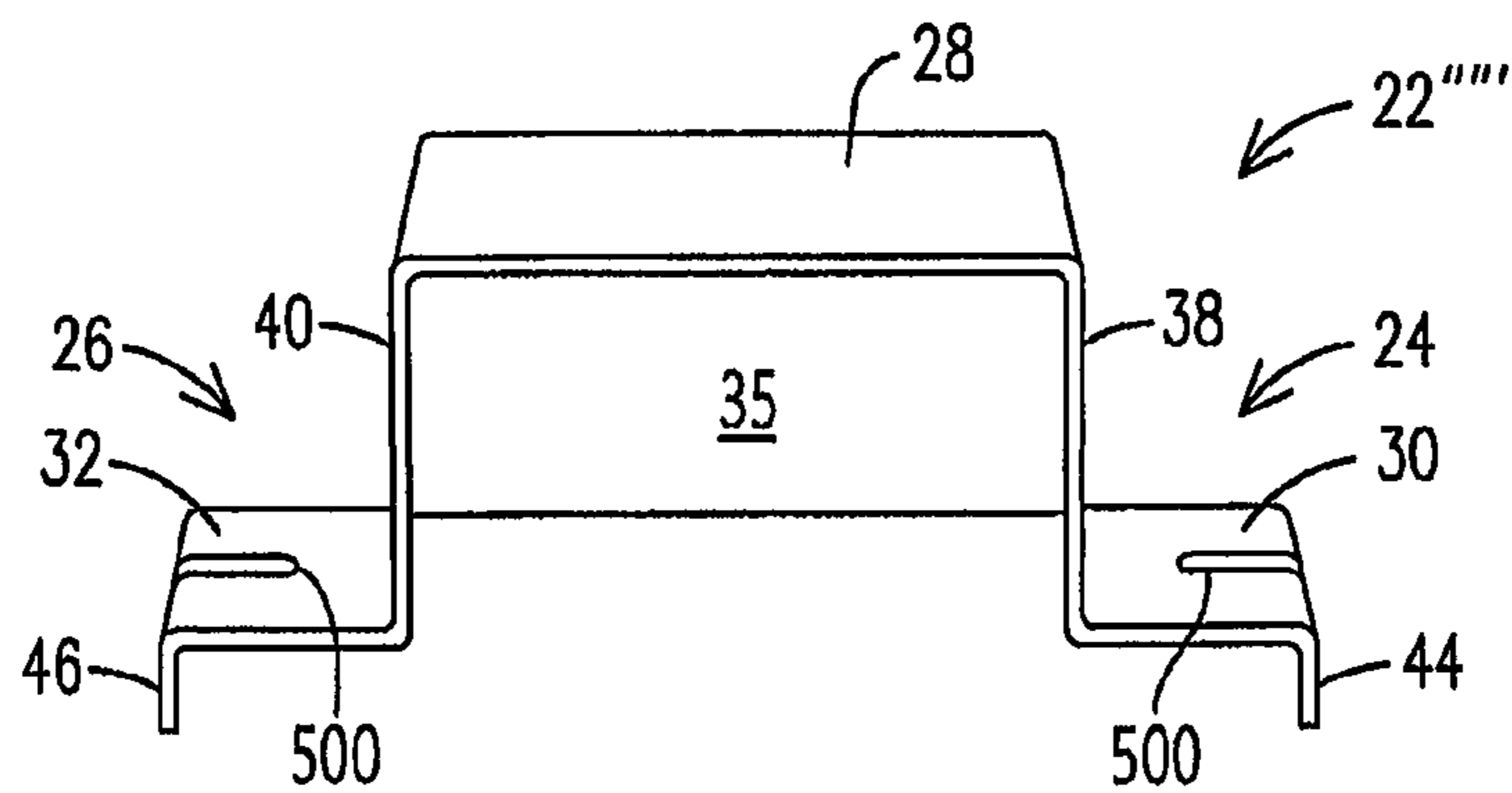
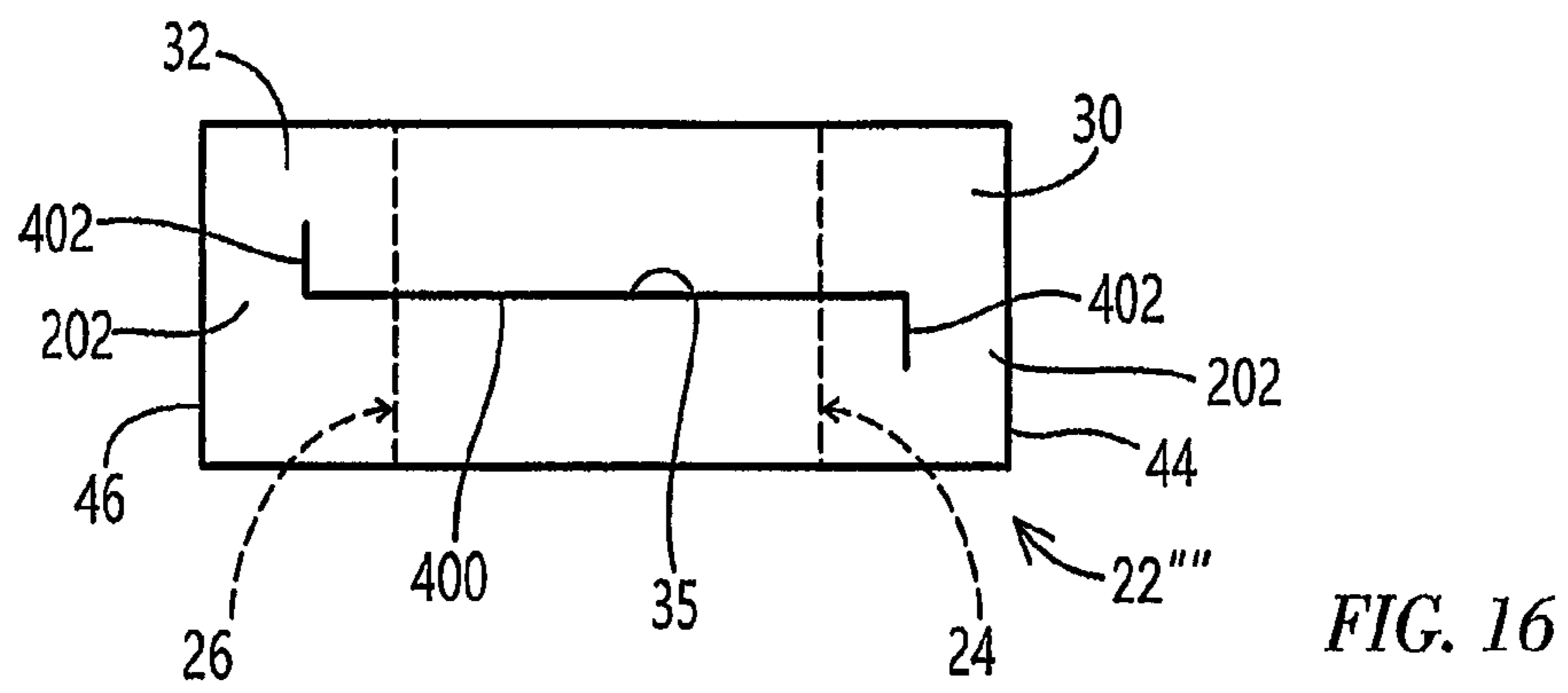
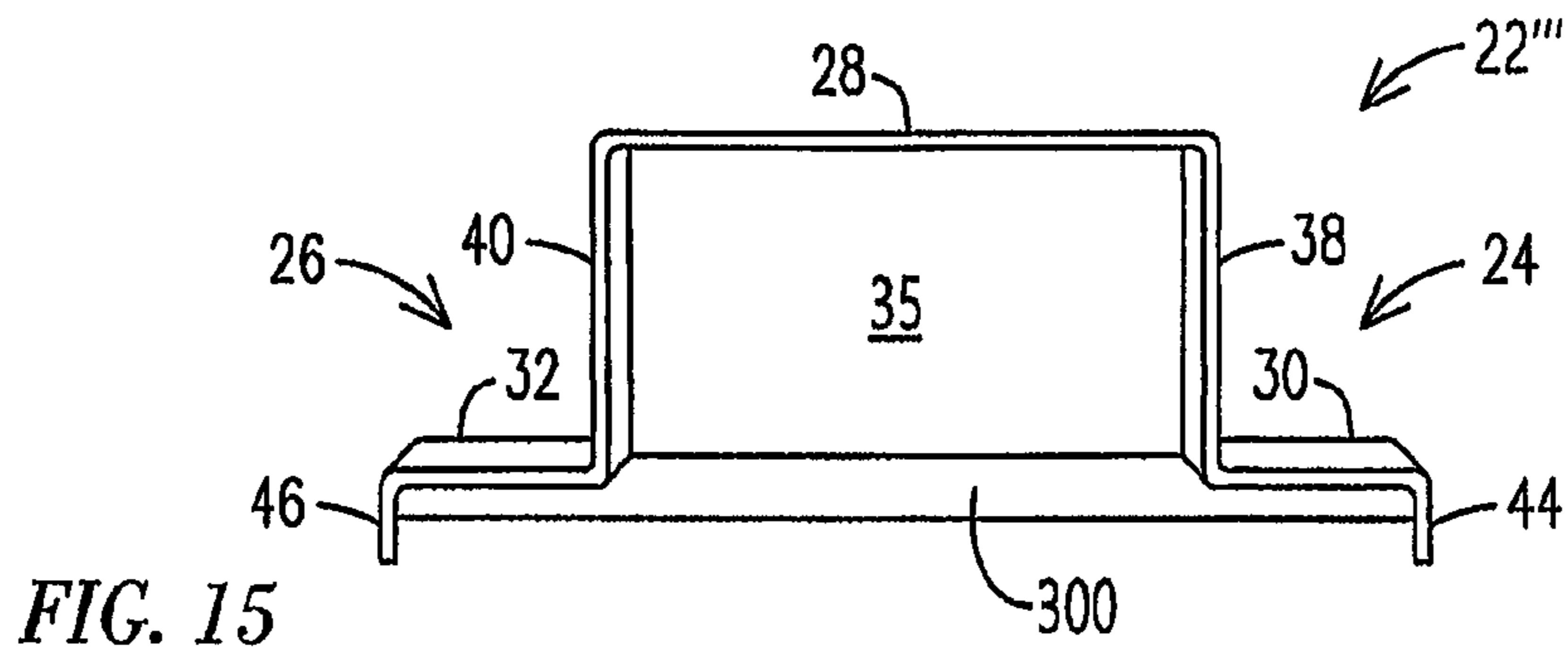

FIG. 14





1

**SYSTEM AND METHOD FOR MAINTAINING  
A MINIMUM SEPARATION BETWEEN  
PALLET POSITIONS ON ADJACENT  
RACKS**

**Matter enclosed in heavy brackets [ ] appears in the original patent but forms no part of this reissue specification; matter printed in italics indicates the additions made by reissue; a claim printed with strikethrough indicates that the claim was canceled, disclaimed, or held invalid by a prior post-patent action or proceeding.**

CROSS-REFERENCE TO RELATED  
APPLICATIONS

This application is a Continuation-In-Part of and claims the benefit to co-pending U.S. Ser. No. 14/324,840 filed Jul. 7, 2014 which claims the benefit of U.S. Provisional Patent Application No. 61/843,538, filed Jul. 8, 2013, both of which are incorporated herein by reference.

FIELD OF THE INVENTION

The present invention relates to racks for mounting pallets, and more particularly, to a system and method for maintaining a minimum separation between pallets mounted on adjacent racks.

BACKGROUND OF THE INVENTION

Pallets are flat transport structures that support goods in a stable fashion as the pallet is lifted by a jacking device such as a forklift, for example. A pallet is the structural foundation of a unit load that enhances handling and storage efficiencies. Goods or shipping containers are often placed on a pallet and secured with strapping, stretch wrap or shrink wrap and then subsequently shipped. While most pallets are made of wood, pallets may also be made from plastic and metal material.

In a warehouse environment, pallets are routinely stored on racks which permit the pallets to be stacked on top of one another in a column form. The racks are typically spaced apart from one another by a sufficient distance, so that stacked pallets on one rack can overhang the rack and still maintain a separation from stacked pallets that overhang an adjacent rack. For safety reasons, various insurance and/or legal regulations require a minimum separation between the stacked pallets on adjacent racks. For example, in the event of a fire in the warehouse, these minimum separation regulations may facilitate water coverage from overhead sprinkler systems between the stacked pallets. The minimum separation regulations may depend on the specific insurance and/or legal regulations.

Various conventional approaches have been proposed to provide a separation between the stacked pallets on adjacent racks, in order to comply with these insurance and/or legal regulations. FIG. 1 illustrates one such approach including a Z-stop bracket 110 to attempt to provide a separation 118 between a first pallet 113 positioned on a first rack 112 and a second pallet 115 positioned on a second rack 114. As illustrated in FIG. 1, the Z-stop bracket 110 is attached to the first rack 112 using an attachment means 116, such as bolts, for example. The first pallet 113 overhangs the first rack 112 and engages the Z-stop bracket 110 in an effort to maintain the separation 118. An additional Z-stop bracket (not shown) may be attached to the second rack 114 in a similar manner

2

as the Z-stop bracket 110 attached to the first rack 112, to engage the second pallet 115 and maintain the separation 118.

BRIEF DESCRIPTION OF THE INVENTION

A system for maintaining a minimum separation between pallets positioned on racks. The system comprising a double back stop. The stop includes: a first and a second back stop configured to prevent lateral movement of the pallets beyond the back stops, the back stops defining a minimum separation between the pallets; and a middle section connecting the back stops includes a vertical cross-member; and one or more of the following: a clip forming a channel affixed to the double back stop, and/or a web affixed to the double back stop, and/or member affixed to the double back stop, and/or a slot in the double back stop.

BRIEF DESCRIPTION OF THE DRAWINGS

A more particular description of the invention briefly described above will be rendered by reference to specific embodiments thereof that are illustrated in the appended drawings. Understanding that these drawings depict only typical embodiments of the invention and are not therefore to be considered to be limiting of its scope, the embodiments of the invention will be described and explained with additional specificity and detail through the use of the accompanying drawings in which:

FIG. 1 is an end view of an exemplary embodiment of a conventional Z-stop bracket attached to a rack to engage a pallet positioned on the rack;

FIG. 2 is a perspective view of an exemplary embodiment of a system for maintaining a minimum separation between a first pallet positioned on a first rack and a second pallet positioned on a second rack according to the present invention;

FIG. 3 is a bottom perspective view of the system of FIG. 2;

FIG. 4 is a perspective view of the system of FIG. 2 without the first and second pallets positioned on the first and second racks;

FIG. 5 is a perspective view of an exemplary embodiment of the double back stop of the system of FIG. 2;

FIG. 6 is a front perspective view of the double back stop of FIG. 5;

FIG. 7 is a side perspective view of the double back stop of FIG. 5;

FIG. 8 is a front view of the double back stop of FIG. 5; FIG. 9 is a top perspective view of an alternate embodiment of the double back stop of the system of FIG. 2;

FIG. 10 is a flowchart illustrating an exemplary embodiment of a method for forming the double back of FIG. 2; and

FIG. 11 is a flowchart illustrating an exemplary embodiment of a method for maintaining a minimum separation between a first pallet positioned on a first rack and a second pallet positioned on a second rack.

FIGS. 12-14 illustrate an alternate embodiment of the invention with a clip forming a channel for receipt of the rack.

FIG. 15 illustrates an alternate embodiment of the invention with a web.

FIG. 16 illustrates an alternate embodiment of the invention with a member (i.e., a combination of the clip and the web).



FIG. 17 illustrates an alternate embodiment of the invention with a slot.

#### DETAILED DESCRIPTION OF THE INVENTION

In describing particular features of different embodiments of the present invention, number references will be utilized in relation to the figures accompanying the specification. Similar or identical number references in different figures may be utilized to indicate similar or identical components among different embodiments of the present invention.

The inventor of the present invention recognized that the conventional approaches to attempt to maintain a separation between the pallets on adjacent racks have several drawbacks. For example, the inventor of the present invention recognized that the installation process for securing the Z-stop bracket 110 to the rack 112 of FIG. 1 is cumbersome, requiring extensive attachment means, such as multiple through bolts. Thus, the inventor proposed the system described herein, which includes a double back stop that involves minimal installation steps, to attach to adjacent racks and maintain a minimum separation between pallets positioned on the adjacent racks.

Additionally, the inventor of the present invention recognized that the Z-stop bracket 110 is inherently weak relative to typical lateral loads imposed by the pallets 113, 115 and thus frequently bends during use, thereby failing to maintain the separation 118 between the pallets 113, 115. Thus, the inventor proposed the system with the double back stop described herein, which maintains structural integrity in the presence of typical lateral loads imposed by pallets 113, 115 and thus maintains a minimum separation between pallets positioned on adjacent racks.

FIGS. 2-3 illustrate a system 10 for maintaining a minimum separation 12 between a first pallet 14 positioned on a first rack 16 and a second pallet 18 positioned on a second rack 20. A double back stop 22 is attached to the first rack 16 and the second rack 20, to maintain the minimum separation 12 between the first pallet 14 and the second pallet 18. For purposes of clarity, FIG. 2 omits the second pallet 18 so that the double back stop 22 is visible between the first and second racks 16, 20. FIG. 3 illustrates the second pallet 18 positioned on the second rack 20 and the minimum separation 12 maintained between the first and second pallets 14, 18 by the double back stop 22. In an exemplary embodiment, the minimum separation 12 may be selected based on one or more insurance and/or legal regulations. In another exemplary embodiment, the minimum separation 12 may be selected within a range of 5-7 inches, such as 6 inches, for example. However, the embodiments of the system 10 and the double back stop 22 are not limited to any specific range of minimum separation 12 and may be employed to maintain any minimum separation between pallets positioned on adjacent racks.

As further illustrated in FIGS. 2-3, the double back stop 22 includes a first back stop 24 attached to the first rack 16 to prevent lateral movement of the first pallet 14 beyond the first back stop 24. The double back stop 22 depicted in FIGS. 2-3 also includes a second back stop 26 attached to the second rack 20 to prevent lateral movement of the second pallet 18 beyond the second back stop 26. As illustrated in FIG. 3, a minimum distance 25 is maintained between the first backstop 24 and the second backstop 26, so that the minimum separation 12 is maintained between the first and second pallets 14, 18. In an exemplary embodiment, the minimum distance 25 is approximately equal to the mini-

um separation 12. However, the minimum distance 25 may be less than the minimum separation 12, provided that the minimum separation 12 is maintained between the pallets 14, 18. FIGS. 2-3 further illustrate that the minimum distance 25 between the first and second backstops 24, 26 is maintained by a middle section 28 connecting the first back stop 24 to the second back stop 26 such that the first back stop 24 and the second back stop 26 are spaced apart by the minimum distance 25. As illustrated in FIG. 3, a length of the middle section 28 between the first back stop 24 and the second back stop 26 is the minimum distance 25.

FIG. 4 illustrates the system 10 without the first and second pallets 14, 18 positioned on the first and second racks 16, 20. As shown in FIG. 4, the first and second racks 16, 20 include a grating 58 that extends across a top of the first and second racks 16, 20 and over an outer surface 66 of a side 60 of the first and second racks 16, 20. However, the grating 58 does not extend beyond the outer surface 66 of the side 60 of the first and second racks 16, 20 at attachment locations 62, 64 along the first and second racks 16, 20, where the first and second back stops 24, 26 are attached to the side 60 of the first and second rack 16, 20. As further illustrated in FIG. 4, the first and second back stop 24, 26 attach to the racks 16, 20 by extending over an inner surface 68 of the side 60 of the first and second side racks 16, 20 to the attachment locations 62, 64. The first and second racks 16, 20 and the grating 58 structural arrangement of FIG. 4 is merely one exemplary embodiment of a pair of racks that can be used with the double back stop 22 of the present invention. Indeed, the embodiments of the double back stop 22 discussed herein may be used to maintain the minimum separation 12 between pallets positioned on any pair of adjacent racks constructed from any structural components.

FIG. 5 illustrates the double back stop 22 that is attached to the first and second racks 16, 20 of the system 10 discussed above. The double back stop 22 includes the first back stop 24 discussed above which includes a first horizontal member 30 configured to extend across a top of the first rack 16. The first back stop 24 also includes a first back stop member 38 to extend upward from the first horizontal member 30 by a height 42 to prevent lateral movement of the first pallet 14 beyond the first back stop 24. In an exemplary embodiment, the height 42 may be selected based on a height of the first pallet 14. For example, the height 42 may be selected to be less than the height of the first pallet 14. In an exemplary embodiment, the height 42 may be selected in a range of 3-5 inches, such as 4 inches, for example. The first back stop 24 also includes a first attachment member 44 that extends downward from the first horizontal member 30 by a length along the inner surface 68 of the side 60 of the first rack 16 to attach the first back stop 24 to the first rack 16. In an exemplary embodiment, the length of the first attachment member 44 may be selected in a range of 1-2 inches, such as 1 inch, for example.

As illustrated in FIG. 5, the double back stop 22 also includes the second back stop 26 discussed above which includes a second horizontal member 32 configured to extend across a top of the second rack 20. The second back stop 26 also includes a second back stop member 40 to extend upward from the second horizontal member 32 by a height 42 to prevent lateral movement of the second pallet 18 beyond the second back stop 26. As with the first back stop member 38, the height 42 of the second back stop member 40 may be selected based on a height of the second pallet 18. For example, the height 42 may be selected to be less than the height of the second pallet 18. In an exemplary embodiment, the height 42 may be selected within a range



5

of 3-5 inches, such as 4 inches, for example. The second back stop 26 also includes a second attachment member 46 that extends downward from the second horizontal member 32 by a length along the inner surface 68 of the side 60 of the second rack 20 to attach the second back stop 26 to the second rack 20.

FIG. 5 further illustrates that the first attachment member 44 includes a hole [43] 47 configured to pass a fastener (not shown) through the first attachment member 44 and the first rack 16, in order to attach the first back stop 24 to the first rack 16. Similarly, the second attachment member 46 includes a hole [43] 47 configured to pass a fastener through the second attachment member 46 and the second rack 20, in order to attach the second back stop 26 to the second rack 20. After the first and second attachment members 44, 46 are extended along the inner surface 68 of the side 60 of the first and second racks 16, 20, the fastener is passed through the holes 43 and into the inner surface 68, to secure the first and second back stops 24, 26 to the first and second racks 16, 20. In an exemplary embodiment, the holes [43] 47 may have a diameter in a range of 1/8-1/2 inches, such as 1/4 inches for example.

FIG. 5 further illustrates that the double back stop 22 includes the middle section 28 with a horizontal cross-member 29 that interconnects the first back stop member 38 with the second back stop member 40 along a top of the first back stop member 38 and a top of the second back stop member 40. As illustrated in FIG. 5, the length of the horizontal cross-member 29 is the minimum distance 25. Additionally, as illustrated in FIG. 5, the middle section 28 includes a vertical cross-member 35 that interconnects the first back stop member 38 to the second back stop member 40 along a center 37 of a width of the first and second back stop members 38, 40. Although the embodiment of the vertical cross-member 35 depicted in FIG. 5 interconnects the first and second back stop members 38, 40 along the center 37 of their width, the embodiments of the present invention may position the vertical cross-member 35 to interconnect the first and second back stop members 38, 40 at any region along a width of the first and second back stop members 38, 40. In an exemplary embodiment, the vertical cross-member 35 enhances the structural integrity of the double back stop 22 in the presence of lateral loads imposed by the first and second pallets 14, 18 against the first and second back stop members 38, 40. In an exemplary embodiment, when the vertical cross-member 35 is integrally connected to the double back stop 22 other than with a welding operation, the vertical cross-member 35 enhances the structural integrity of the double back stop 22, to withstand up to 3000 pounds of lateral force imposed by the first and second pallets 14, 18 on the first and second back stop members 38, 40. In another exemplary embodiment, when the vertical cross-member 35 is integrally connected to the double back stop 22 with a welding operation, the structural integrity of the double back stop 22 is enhanced to withstand up to 4900 pounds of lateral force imposed by the first and second pallets 14, 18 on the first and second back stop members 38, 40. These numerical force thresholds are merely exemplary and the embodiments of the present invention are not limited to these thresholds and the double back stop may be designed to withstand greater force threshold of the lateral loads imposed by the first and second racks on the double back stop.

As illustrated in FIG. 5, a length 52 of the double back stop 22 is a sum of a length 48 of the first horizontal member 30, a length 50 of the second horizontal member 32 and the minimum distance 25 length of the middle section 28. As

6

previously discussed, in an exemplary embodiment, the minimum distance 25 is the minimum separation 12. In one exemplary embodiment, the length 48, 50 of each of the first and second horizontal members 30, 32 is one half of the difference between the length 52 of the double back stop 22 and the minimum separation 12. In another exemplary embodiment, the length 48, 50 of each of the first and second horizontal members 30, 32 is in a range of 4-6 inches, such as 5 inches, for example. As further illustrated in FIG. 2, the first and second horizontal members 30, 32 each include a rack overhang portion 54 that extends over the side 60 of the rack 16, 20 to attach the double back stop 22 to the racks 16, 20. Additionally, as illustrated in FIG. 2, the first and second horizontal members 30, 32 each include a pallet overhang portion 56 that vertically supports the first and second pallets 14, 18 between the first and second racks 16, 20.

In one embodiment of the present invention, the first and second back stop members 38, 40 and the horizontal cross-member 29 are made from an integral piece of material, such as an integral piece of steel material, for example. The vertical cross-member 35 is integrally connected to the integral piece of material, such as with a welding operation, for example. FIG. 3 depicts the welding joint 27 between the vertical cross-member 35 and the first and second back stop members 38, 40 and the horizontal cross-member 29. As illustrated in FIG. 5, to form the double back stop 22, the integral piece of material is bent along a first line 31, to form the first back stop member 38 and is bent along a second line 33, to form the second back stop member 40. The integral piece of material is then bent along a third line 39, to form the first horizontal member 30 and is bent along a fourth line 41, to form the second horizontal member 32. The integral piece of material is then bent along a fifth line 43, to form the first attachment member 44 and is bent along a sixth line 45, to form the second attachment member 46. The lines 31, 33, 39, 41, 43, 45 are spaced apart along the integral piece of material, based on the desired lengths of each of the parts of the double back stop 22. For example, the first and second lines 31, 33 are spaced apart by the minimum separation 12, so that the minimum distance 25 length of the middle section 28 is the minimum separation 12. In an exemplary embodiment, the integral piece of material is bent at approximate orthogonal angles along each of the lines 31, 33, 39, 41, 43, 45, as depicted in FIG. 5. In another exemplary embodiment, the integral piece of material may have a length in a range of 14-17 inches, a width in a range of 2-4 inches and a thickness in a range of 1/16-1/4 inches, for example.

FIGS. 6-8 illustrate additional views of the double back stop 22 from different angular perspectives, with the structural features previously discussed.

FIG. 9 illustrates an alternate embodiment of the double back stop 22' that can be used to maintain the minimum separation 12 between the pallets 14, 18 in the system 10 of FIGS. 2-3. The double back stop 22' includes the middle section 28' that connects the first back stop 24' to the second back stop 26' with a vertical cross-member 35' with end 37' and without a horizontal cross-member. As with the middle section 28 of FIG. 5, the length of the middle section 28' is the minimum distance 25. In an exemplary embodiment, the minimum distance 25 is the minimum separation 12 required to be maintained between the pallets 14, 18. Unlike the double back stop 22 of FIG. 5, the first back stop 24', the second back stop 26' and the middle section 28' are not formed from bending an integral piece of material at spaced apart locations. Instead, the middle section 28' is integrally connected to each of the first back stop 24' and the second back stop 26', such as with a welding operation, for example.



FIG. 10 illustrates a flowchart depicting a method 100 for forming the double back stop 22 to maintain the minimum separation 12 between the first pallet 14 positioned on the first rack 16 and the second pallet 18 positioned on the second rack 20. The method 100 starts at 101 by providing 5 an integral piece of material. The method 100 then includes bending 104 the integral piece of material at the first line 31 to form the first back stop member 38 to prevent lateral movement of the first pallet 14 beyond the first back stop member 38, when the first pallet 14 engages the first 10 back stop member 38. The method 100 then involves bending 106 the integral piece of material at the second line 33 spaced from the first line 31 by the minimum separation 12 to form the second back stop member 40 to prevent lateral movement of the second pallet 18 beyond the second back stop member 40 when the second pallet 18 engages the second back stop member 40. Additionally, the bending 106 15 step is performed, to form the horizontal cross member 29 extending the minimum distance 25 between the first back stop member 38 and the second back stop member 40. In an exemplary embodiment, the minimum distance 25 is the minimum separation 12. The method 100 may also include integrally connecting 108 the vertical cross-member 35 to the first back stop member 38, the second back stop member 40 and the horizontal cross member 29 along a region of a 20 width of the first back stop member 38 and the second back stop member 40, such as the center 37 of the width, before the method 100 ends at 109.

FIG. 11 illustrates a flowchart depicting a method [200] 200' for maintaining the minimum separation 12 between the first pallet 14 positioned on the first rack 16 and the second pallet 18 positioned on the second rack 20. The method [200] 200' begins at [201] 201' by providing [202] 202' the double back stop 22 including the first back stop 24, the second back stop 26 and the middle section 28 connecting 35 the first back stop 24 to the second back stop 26 such that the first back stop 24 and the second back stop 26 are spaced apart by the minimum distance 25 as determined by the middle section 28. The method [200] 200' further includes attaching [204] 204' the first back stop 24 to the first rack 16 and the second back stop 26 to the second rack 20. The method [200] 200' further includes positioning [206] 206' the first pallet 14 on the first rack 16 and the second pallet 18 on the second rack 20. The method [200] 200' further includes inhibiting lateral movement [208] 208' of the first 45 pallet 14 beyond the first back stop 24 and the second pallet 18 beyond the second back stop 26 such that the minimum separation 12 is maintained between the first pallet 14 and the second pallet 18, before the method [200] 200' ends at [209] 209'.

FIGS. 12-14 illustrate another alternate embodiment of the invention, double back stop 22". Double back stop 22" includes clips 200. Clips 200 are affixed (e.g., welded) to the double back stop 22" and are spaced from attachment members 44 and 46 to form a channel 202. The channel 202 55 is sufficiently wide for receipt therein of racks 16 and 18. Double back stop 22" may be affixed (e.g., via bolt or screw 88) to racks 16 and/or 18. Clip 200 may be a L-shaped channel member of a flat member.

FIG. 15 illustrates another alternate embodiment of the invention, double back stop 22"". Double back stop 22"" includes a web 300. Web 300 may be integral with vertical cross member 35, or added to vertical cross member 35, or added to the double back stop separately from the vertical cross member 35. Web 300 is affixed (e.g., welded) to double 60 back stop 22"". Web 300 may extend between (or span the space between) attachment members 44 and 46 or may

extend only a portion of the distance between attachment members 44 and 46 or may extend between clips 200. The height (top to bottom) of web 300 may be any height sufficient to add additional lateral strength to the double back stop. The thickness, top to bottom, (or width) of web 300 may be sufficient to add additional lateral strength to the double back stop.

FIG. 16 illustrates another alternate embodiment of the invention, double back stop 22"". Double back stop 22"" combines clips 200 and web 300. Member 400, combined clip 200 and web 300, has bent terminal ends 402. The bent terminal ends 402 define, in part channel 202. Member 400 may be integral with vertical cross member 35, or added to vertical cross member 35, or added to the double back stop separately from the vertical cross member 35. Member 400 15 is affixed (e.g., welded) to double back stop 22"". The height (top to bottom) of member 400 may be any height sufficient to add additional lateral strength to the double back stop. The thickness, top to bottom, (or width) of member 400 may be sufficient to add additional lateral strength to the double back stop.

FIG. 17 illustrates another alternate embodiment of the invention, double back stop 22"". Double back stop 22"" includes slots 500. Slots 500 are formed in the double back stop so that element (i.e., wires) of grating 58 may fit into slots 500 and the double back stop may sit flush (or flat) on the racks 16 and 18. Slots 500 extend from any point on horizontal members 30 and 32 (e.g., mid-point on the horizontal members, but not so limited) to the terminal ends 25 of the attachment members 44 and 46.

The double back stop may include any combination of the clip 200 forming the channel 202, web 300, member 400 and slot 500.

This written description uses examples to disclose embodiments of the invention, including the best mode, and also to enable any person skilled in the art to make and use the embodiments of the invention. The patentable scope of the embodiments of the invention is defined by the claims, and may include other examples that occur to those skilled in the art. Such other examples are intended to be within the scope of the claims if they have structural elements that do not differ from the literal language of the claims, or if they include equivalent structural elements with insubstantial differences from the literal languages of the claims.

That which is claimed is:

1. A system for maintaining a minimum separation between a first pallet positioned on a first rack and a second pallet positioned on a second rack, said system comprising:
  - a double back stop including;
    - a first back stop configured to attach to the first rack and to prevent lateral movement of the first pallet beyond the first back stop;
    - a second back stop configured to attach to the second rack and to prevent lateral movement of the second pallet beyond the second back stop such that the minimum separation is maintained between the first and second pallets; and
    - a middle section to connect the first back stop to the second back stop to maintain a minimum distance between the first back stop and the second back stop such that the minimum separation is maintained between the first and second pallets, the middle section includes a horizontal cross-member [interconnection] 55 *interconnecting* the first back stop [member] with the second backstop [member] along a top of the first and second back [stop member] stops and a vertical cross-member, the vertical cross-member is a vertical plate

that is welded along a center of the first back stop [member], the second back stop [member], and the middle section,

the double back stop withstands lateral forces in the range of 3000 to 4900 pounds; and

*an element consisting of* one or more of the following: a clip forming a channel affixed to the double back stop, and/or a web affixed to the double back stop, and/or a member affixed to the double back stop, and/or a slot in the double back stop.

2. The system of claim 1 *wherein the element* consists of the clip forming the channel.

3. The system of claim 1 *wherein the element* consists of the web affixed to the double back stop.

4. The system of claim 1 *wherein the element* consists of the member affixed to the double back stop.

5. The system of claim 1 *wherein the element* consists of the slot in the double back stop.

6. The system of claim 1 *wherein the element* consists of the clip forming the channel, and the web affixed to the double back stop, and the slot in the double back stop.

7. The system of claim 1 *wherein the element* consists of the member affixed to the double back stop, and the slot in the double back stop.

\* \* \* \* \*