

US00RE48157E

(19) **United States**
(12) **Reissued Patent**
Cannon et al.

(10) **Patent Number: US RE48,157 E**
(45) **Date of Reissued Patent: Aug. 11, 2020**

(54) **SYSTEMS AND METHODS FOR IMPROVED DIGITAL RF TRANSPORT IN DISTRIBUTED ANTENNA SYSTEMS**

(56) **References Cited**

U.S. PATENT DOCUMENTS

(71) Applicant: **CommScope Technologies LLC**, Hickory, NC (US)

4,183,054 A 1/1980 Patisaul et al.
4,611,323 A 9/1986 Hessenmuller
(Continued)

(72) Inventors: **Jeffrey J. Cannon**, Victoria, MN (US);
Dean Zavadsky, Shakopee, MN (US);
Philip M. Wala, Savage, MN (US)

FOREIGN PATENT DOCUMENTS

(73) Assignee: **CommScope Technologies LLC**, Hickory, NC (US)

CN 101019452 A 8/2007
CN 101227242 A 7/2008
(Continued)

(21) Appl. No.: **15/423,757**

OTHER PUBLICATIONS

(22) Filed: **Feb. 3, 2017**

Australian Patent Office, "Office Action for Serial No. 2010204862", "from Foreign Counterpart of U.S. Appl. No. 13/616,135", dated Sep. 12, 2014, pp. 1-3, Published in: AU.

Related U.S. Patent Documents

(Continued)

Reissue of:

(64) Patent No.: **8,948,155**
Issued: **Feb. 3, 2015**
Appl. No.: **13/616,135**
Filed: **Sep. 14, 2012**

Primary Examiner — Adam L Basehoar
(74) *Attorney, Agent, or Firm* — Fogg & Powers LLC

U.S. Applications:

(63) Continuation of application No. 12/686,488, filed on Jan. 13, 2010, now Pat. No. 8,270,387.

(Continued)

(51) **Int. Cl.**
H04J 3/00 (2006.01)
H04L 27/00 (2006.01)
(Continued)

(57) **ABSTRACT**

Systems and methods for improved digital RF transport in a DAS are provided. In one embodiment, a transceiver comprises: a receive path circuit including an RF reception interface coupled to an ADC, the ADC receiving a down-converted analog RF spectrum from the RF reception interface and producing a digitized RF spectrum at an input sampling rate; a logic device receiving the digitized RF spectrum and producing a first set of baseband data samples at a first sampling rate, corresponding to a first spectral region of the analog RF spectrum and a second set of baseband data samples at a second sampling rate, corresponding to a second spectral region of the analog RF spectrum. The logic device maps the first set and second sets of baseband data samples to a respective first set and second set of timeslots of a serial data stream transport frame.

(52) **U.S. Cl.**
CPC **H04L 27/0002** (2013.01); **H04L 27/144** (2013.01); **H04L 27/2338** (2013.01); **H04W 88/085** (2013.01)

(58) **Field of Classification Search**
CPC H04L 27/0002; H04L 27/144; H04L 27/2338; H04W 88/085

(Continued)

57 Claims, 10 Drawing Sheets

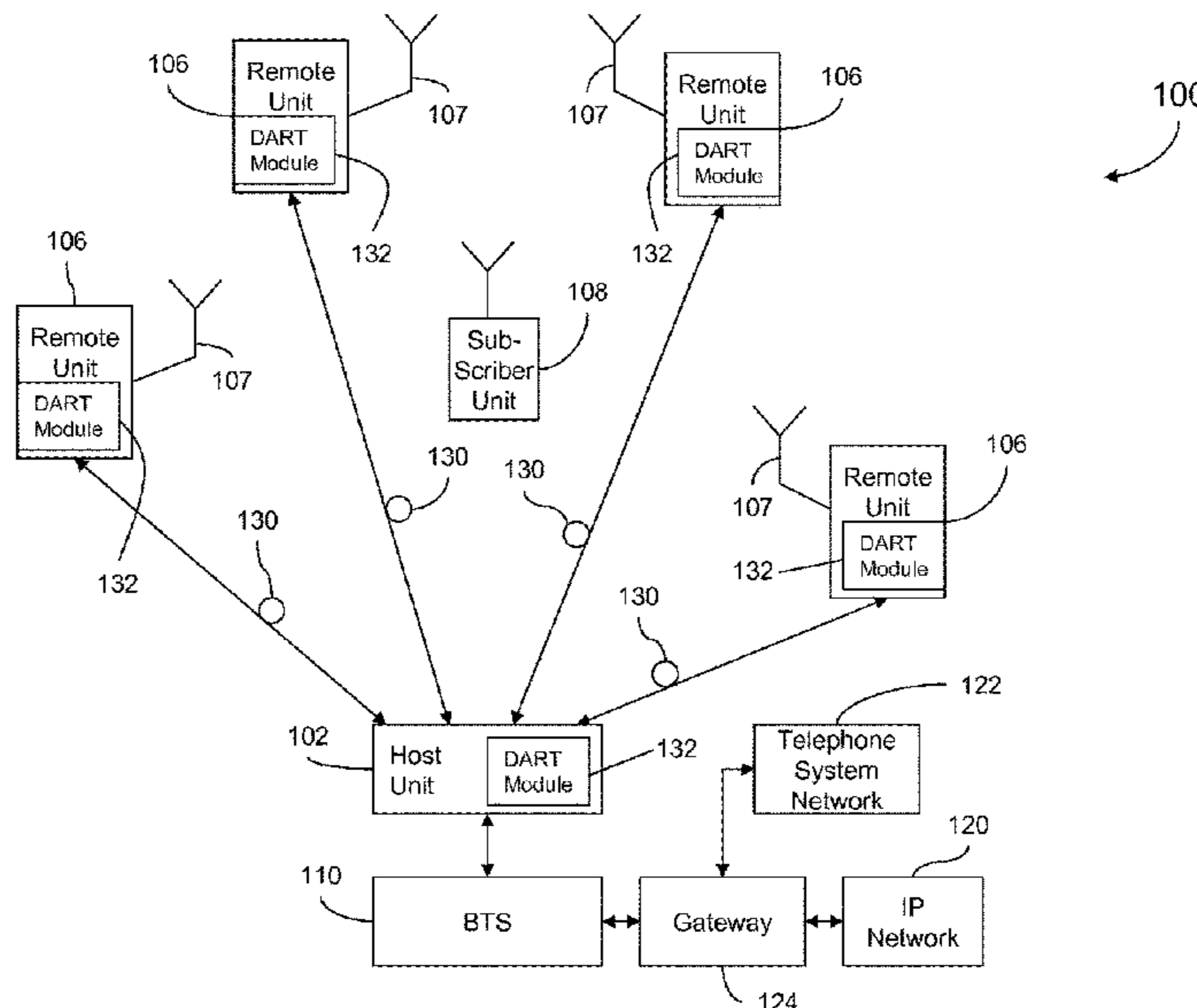

Related U.S. Application Data

- (60) Provisional application No. 61/144,349, filed on Jan. 13, 2009.
- (51) **Int. Cl.**
H04L 27/144 (2006.01)
H04L 27/233 (2006.01)
H04W 88/08 (2009.01)
- (58) **Field of Classification Search**
 USPC 370/345
 See application file for complete search history.

(56) **References Cited**

U.S. PATENT DOCUMENTS

4,628,501	A	12/1986	Loscoe	
4,654,843	A	3/1987	Roza et al.	
4,691,292	A	9/1987	Rothweiler	
4,999,831	A	3/1991	Grace	
5,193,109	A	3/1993	Chien-Yeh Lee	
5,243,598	A	9/1993	Lee	
5,321,849	A	6/1994	Lemson	
5,339,184	A	8/1994	Tang	
5,818,883	A	10/1998	Smith et al.	
5,898,693	A	4/1999	Vecchi et al.	
6,016,311	A *	1/2000	Gilbert	H04B 7/2646 370/280
8,135,102	B2	3/2012	Wiwel et al.	
8,270,387	B2 *	9/2012	Cannon et al.	370/345
8,948,155	B2	2/2015	Cannon et al.	
8,958,410	B2 *	2/2015	Fischer	H04W 88/085 370/345
2007/0238457	A1	10/2007	Wala	
2008/0013639	A1	1/2008	Rick et al.	
2008/0013654	A1	1/2008	Rick et al.	
2008/0019706	A1	1/2008	Levinson et al.	
2008/0181171	A1 *	7/2008	Koziy	H04W 88/085 370/328
2008/0240225	A1 *	10/2008	Zavadsky	H04J 3/1629 375/240
2011/0135013	A1 *	6/2011	Wegener	H03M 7/40 375/241

FOREIGN PATENT DOCUMENTS

EP	0391597	10/1990
EP	0391597 A2	10/1990
WO	9115927	10/1991
WO	9115927 A1	10/1991
WO	2006005220 A1	1/2006
WO	2008119025	10/2008
WO	2008119025 A1	10/2008

OTHER PUBLICATIONS

European Patent Office, "Communication pursuant to Article 94(3) from EP Application No. 10732015.2 dated Feb. 22, 2018", from Foreign Counterpart to U.S. Appl. No. 12/686,488, pp. 1-5, Published: EP.

European Patent Office, "Communication pursuant to Article 94(3) from EP Application No. 10732015.2 dated Mar. 28, 2017", from Foreign Counterpart to U.S. Appl. No. 12/686,488, pp. 1-6, Published: EP.

European Patent Office, "Communication under Rule 71(3) from EP Application No. 10732015.2 dated Mar. 13, 2019", from Foreign Counterpart to U.S. Appl. No. 12/686,488, pp. 1-45, Published: EP.

European Patent Office, "Extended European Search Report from EP Application No. 10732015.2 dated Aug. 19, 2014", from Foreign Counterpart to U.S. Appl. No. 12/686,488, pp. 1-7, Published: EP.

International Bureau, "International Preliminary Report on Patentability from PCT Application No. PCT/US2010/020842 dated Jul. 28, 2011", from Foreign Counterpart to U.S. Appl. No. 12/686,488, pp. 1-6, Published: WO.

International Searching Authority, "International Search Report and Written Opinion from PCT Application No. PCT/US2010/020842 dated Aug. 5, 2010", from Foreign Counterpart to U.S. Appl. No. 12/686,488, pp. 1-9, Published: WO.

State Intellectual Property Office, P.R. China, "First Office Action from CN Application No. 201080004461.6 dated Sep. 24, 2013", from Foreign Counterpart to U.S. Appl. No. 12/686,488, pp. 1-17, Published: CN.

State Intellectual Property Office, P.R. China, "First Office Action from CN Application No. 201510316252.X dated Jun. 7, 2016", from Foreign Counterpart to U.S. Appl. No. 12/686,488, pp. 1-19, Published: CN.

State Intellectual Property Office, P.R. China, "Second Office Action from CN Application No. 201080004461.6 dated Jun. 17, 2014", from Foreign Counterpart to U.S. Appl. No. 12/686,488, pp. 1-7, Published: CN.

State Intellectual Property Office, P.R. China, "Second Office Action from CN Application No. 201510316252.X dated Mar. 3, 2017", from Foreign Counterpart to U.S. Appl. No. 12/686,488, pp. 1-13, Published: CN.

State Intellectual Property Office, P.R. China, "Third Office Action from CN Application No. 201080004461.6 dated Dec. 5, 2014", from Foreign Counterpart to U.S. Appl. No. 12/686,488, pp. 1-8, Published: CN.

U.S. Patent and Trademark Office, File History from U.S. Appl. No. 13/616,135, 280 Pages, Published: US.

U.S. Patent and Trademark Office, "Notice of Allowance", U.S. Appl. No. 12/686,488, dated Apr. 4, 2012, pp. 1-15, Published: US.

U.S. Patent and Trademark Office, "Notice of Allowance", U.S. Appl. No. 12/686,488, dated May 16, 2012, pp. 1-10, Published: US.

European Patent Office, "Extended European Search Report from EP Application No. 19187936.0", from Foreign Counterpart to U.S. Appl. No. 12/686,488, dated Sep. 4, 2019, pp. 1-10, Published: EP.

State Intellectual Property Office, P.R. China, "Second Office Action from CN Application No. 201080004461.6 mailed Jun. 17, 2014", "From Foreign Counterpart of U.S. Appl. No. 12/686,488", Jun. 17, 2014, pp. 1-7, Published in: CN.

European Patent Office, "Extended European Search Report from EPO Application No. 10732015.2 mailed Aug. 19, 2014", "from Foreign Counterpart of U.S. Appl. No. 12/686,488", Aug. 19, 2014, pp. 17, Published in: EP.

State Intellectual Property Office, P.R. China, "First Office Action", "from Foreign Counterpart of U.S. Appl. No. 12/686,488", Sep. 24, 2013, pp. 1-17, Published in: CN.

Grace, Martin K., "Synchronous Quantized Subcarrier Multiplexing for Transport of Video, Voice and Data", "IEEE Journal on Selected Areas in Communications", Sep. 1990, pp. 1351-1358, vol. 8, No. 7, Publisher: IEEE.

Harvey et al., "Cordless Communications Utilising Radio Over Fibre Techniques for the Local Loop", "IEEE International Conference on Communications", Jun. 1991, pp. 1171-1175, Publisher: IEEE.

International Searching Authority, "International Search Report and Written Opinion", "from Foreign Counterpart of U.S. Appl. No. 12/686,488", Mailed Aug. 5, 2010, pp. 1-9, Published in: WO.

U.S. Patent and Trademark Office, "Notice of Allowance", "U.S. Appl. No. 12/686,488", May 16, 2012, pp. 1-10.

U.S. Patent and Trademark Office, "Notice of Allowance", "U.S. Appl. No. 12/686,488", Apr. 4, 2012, pp. 1-15.

International Preliminary Examining Authority, "International Preliminary Report on Patentability", "from Foreign Counterpart of U.S. Appl. No. 12/686,488", Jul. 28, 2011, pp. 1-6.

Australian Patent Office, "Office Action for Serial No. 2010204862", "from Foreign Counterpart of U.S. Appl. No. 13/616,135", Sep. 12, 2014, pp. 1-3, Published in: AU.

* cited by examiner

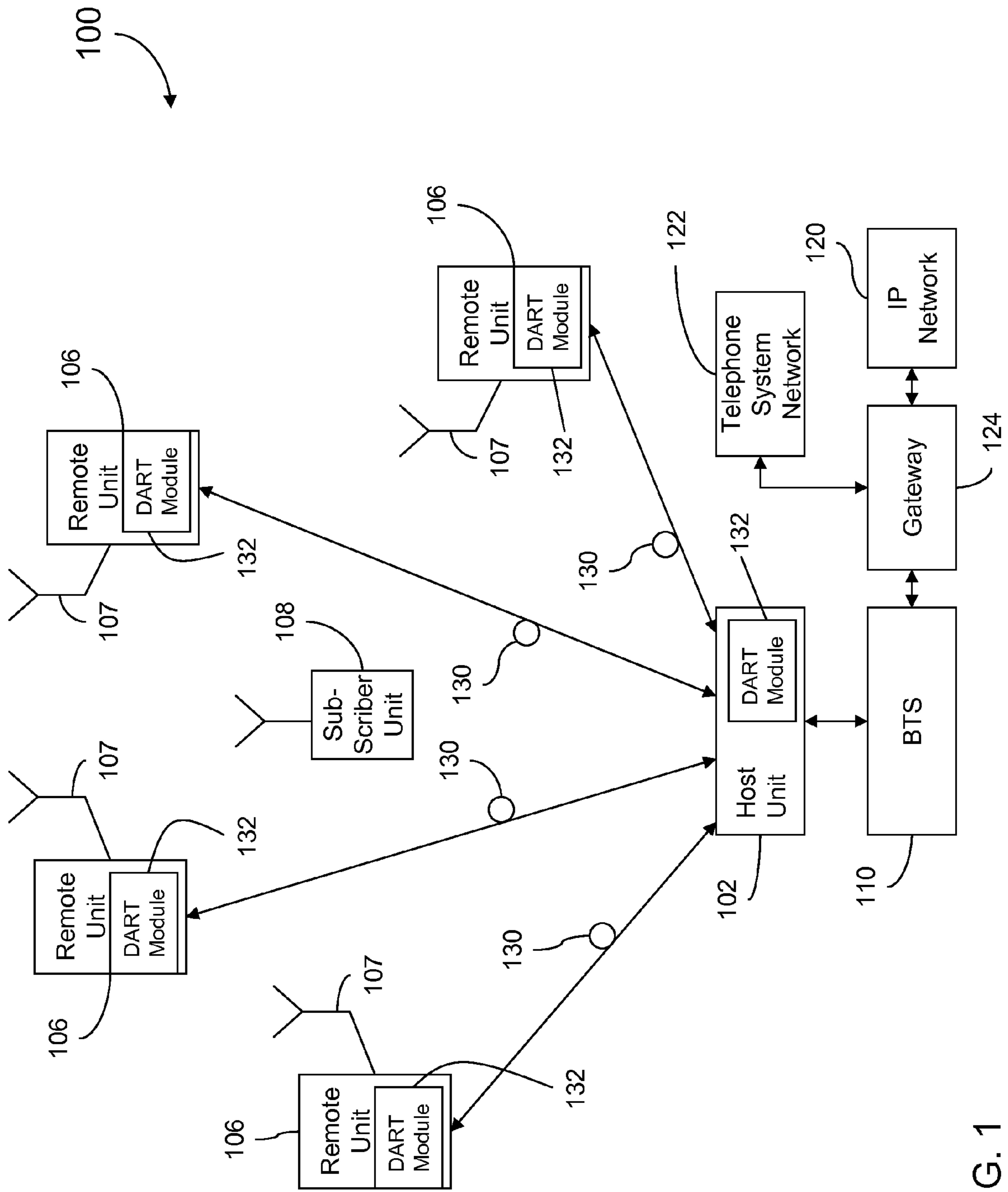

FIG. 1

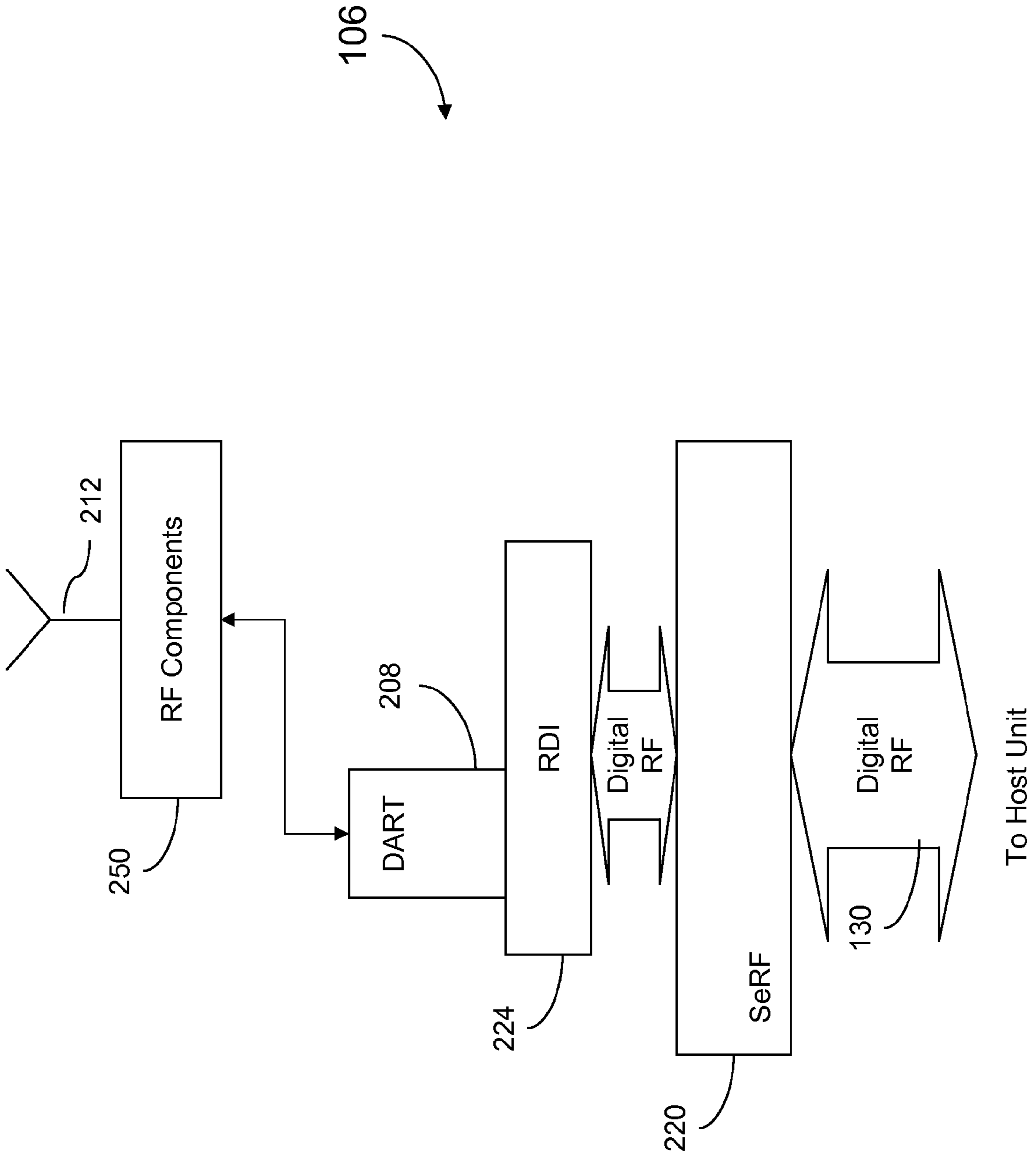

FIG. 2

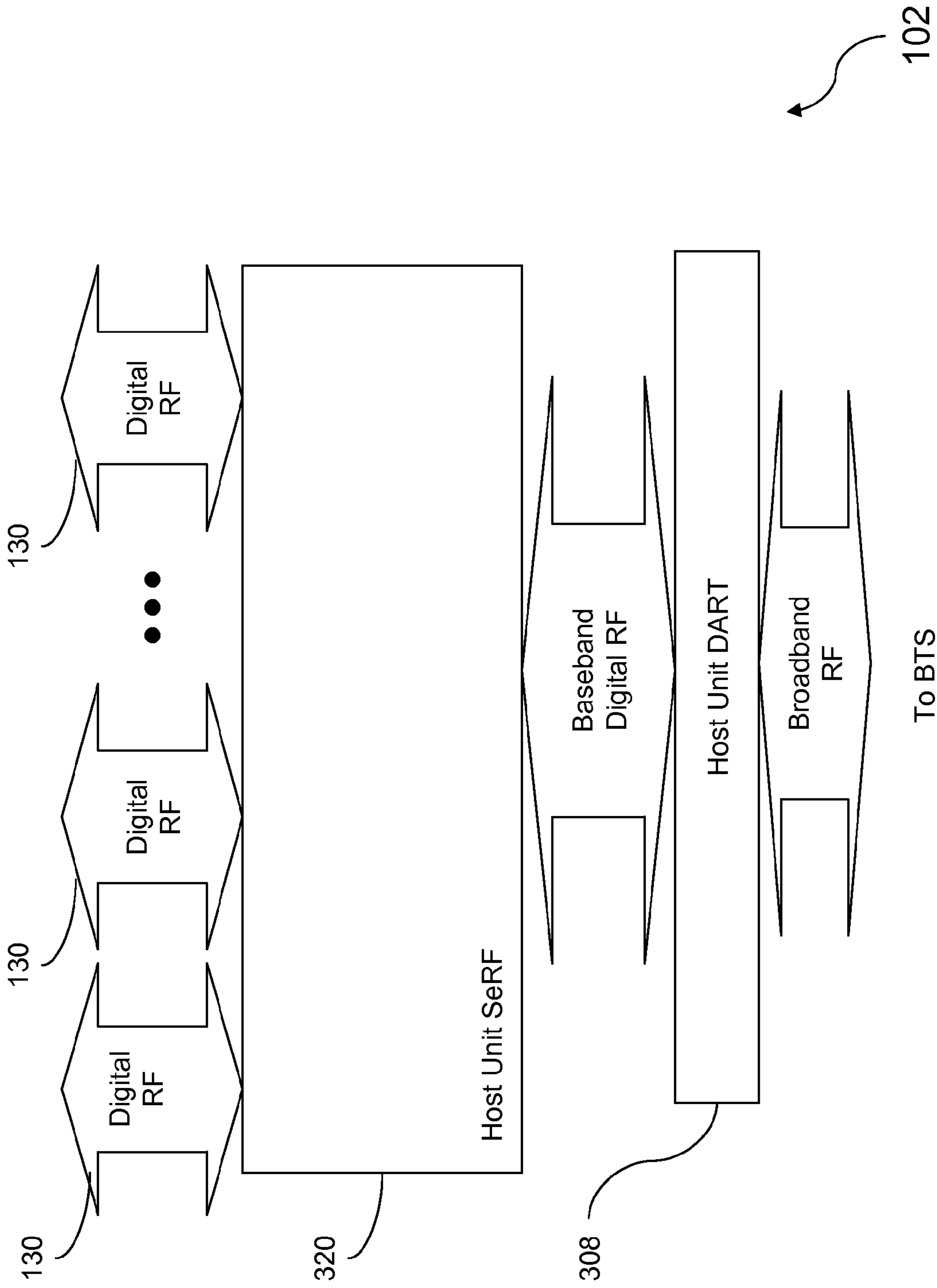

FIG. 3

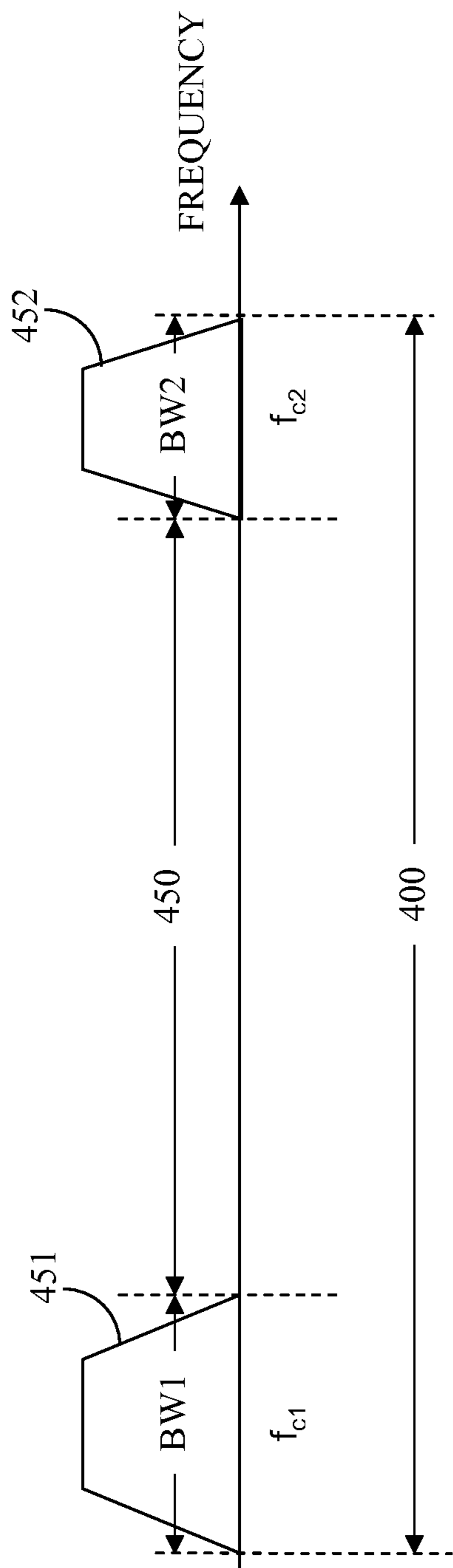

Fig. 4A

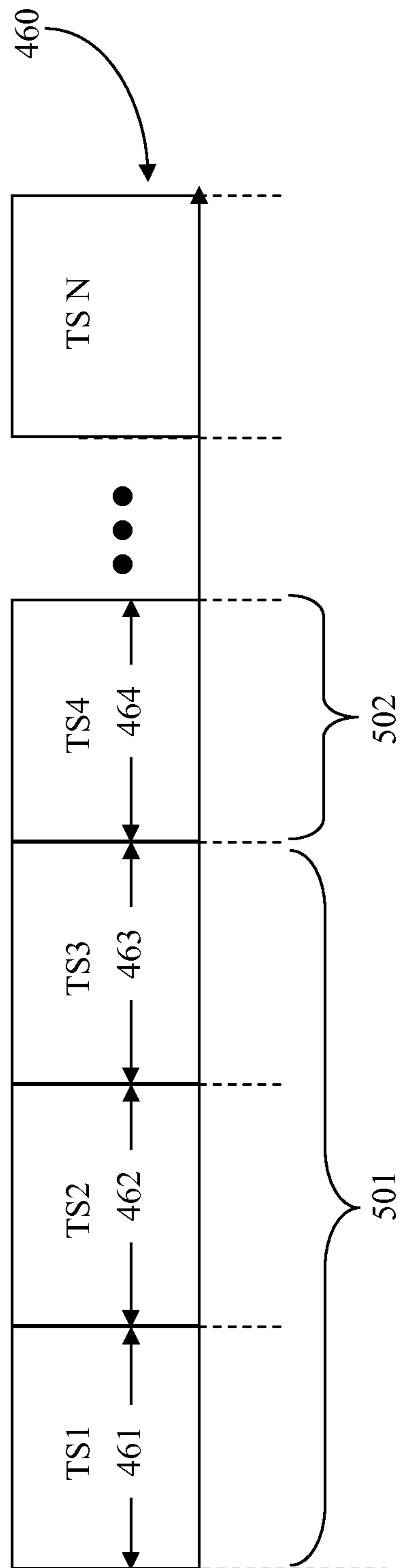

Fig. 4B

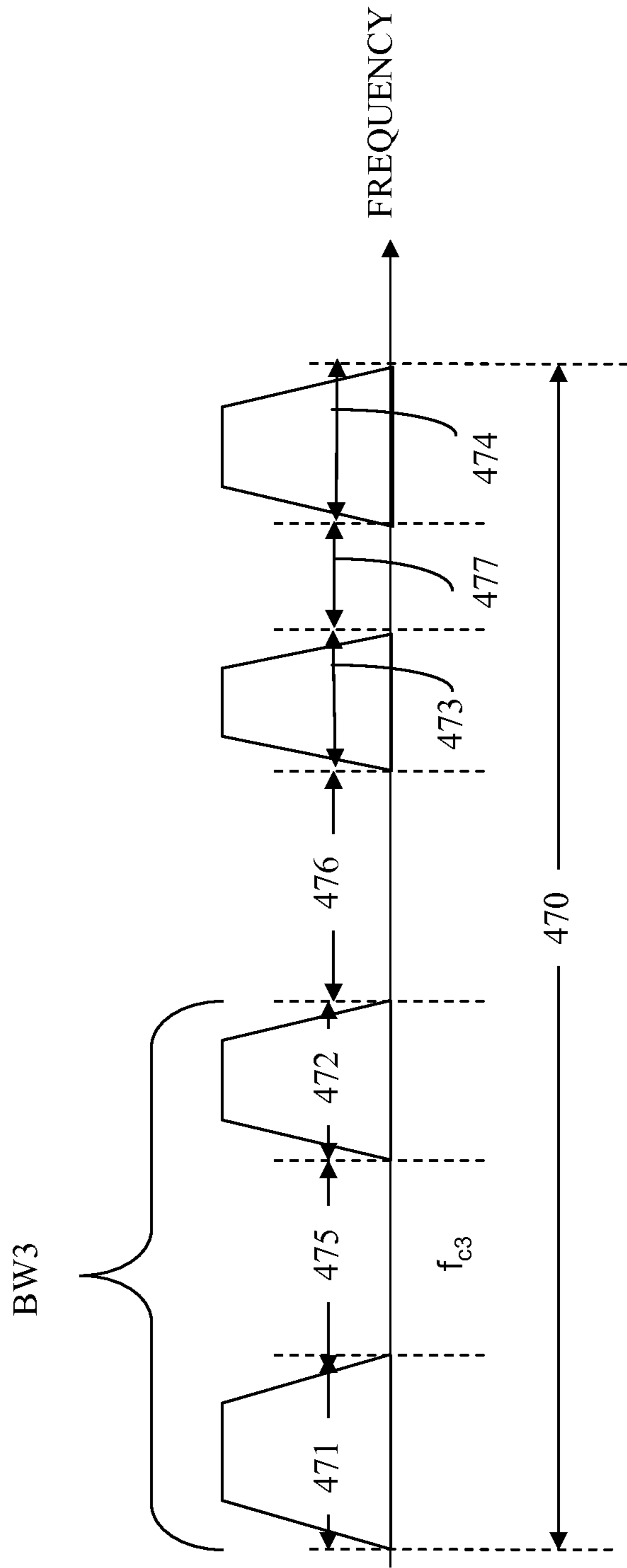

Fig. 4C

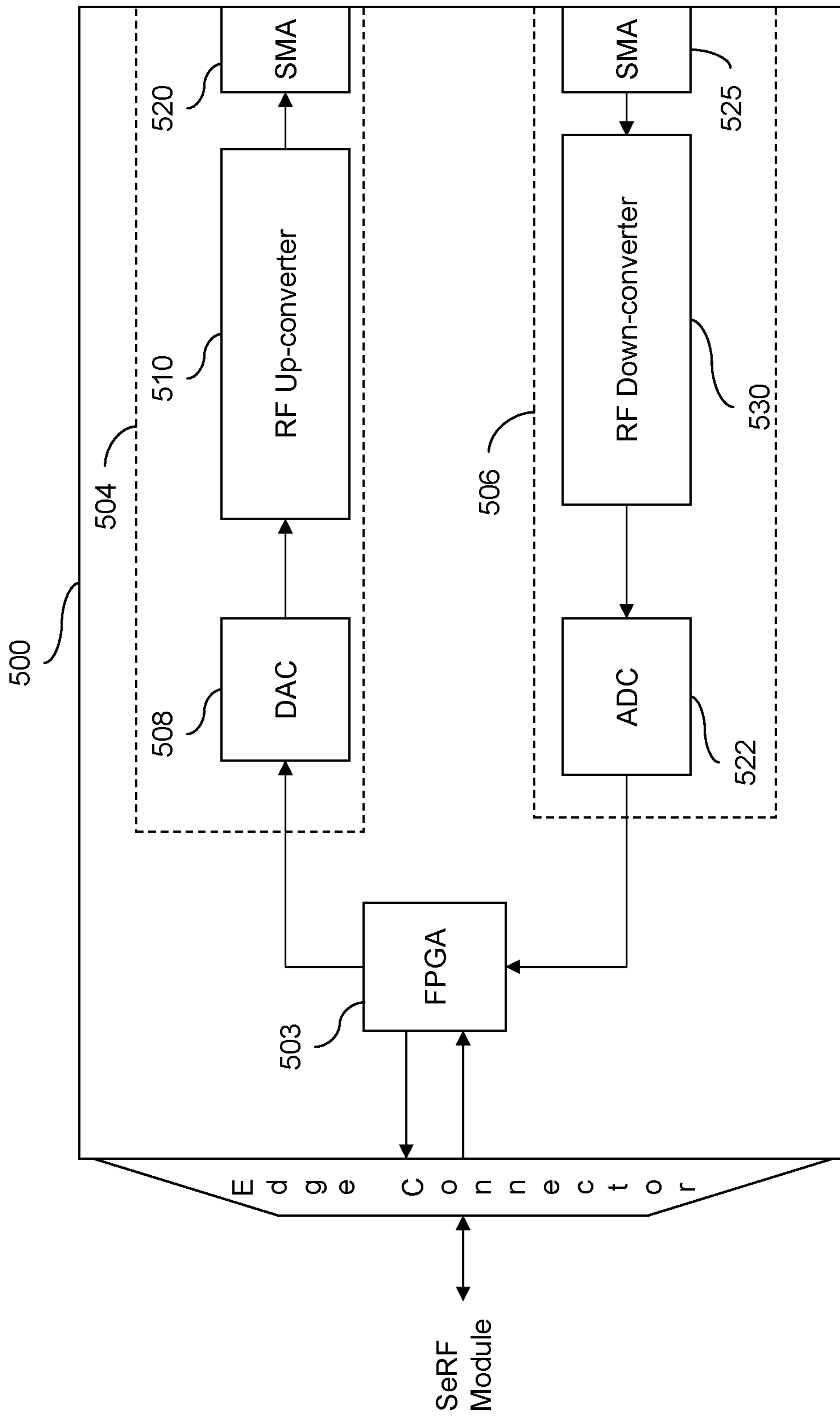

Fig. 5

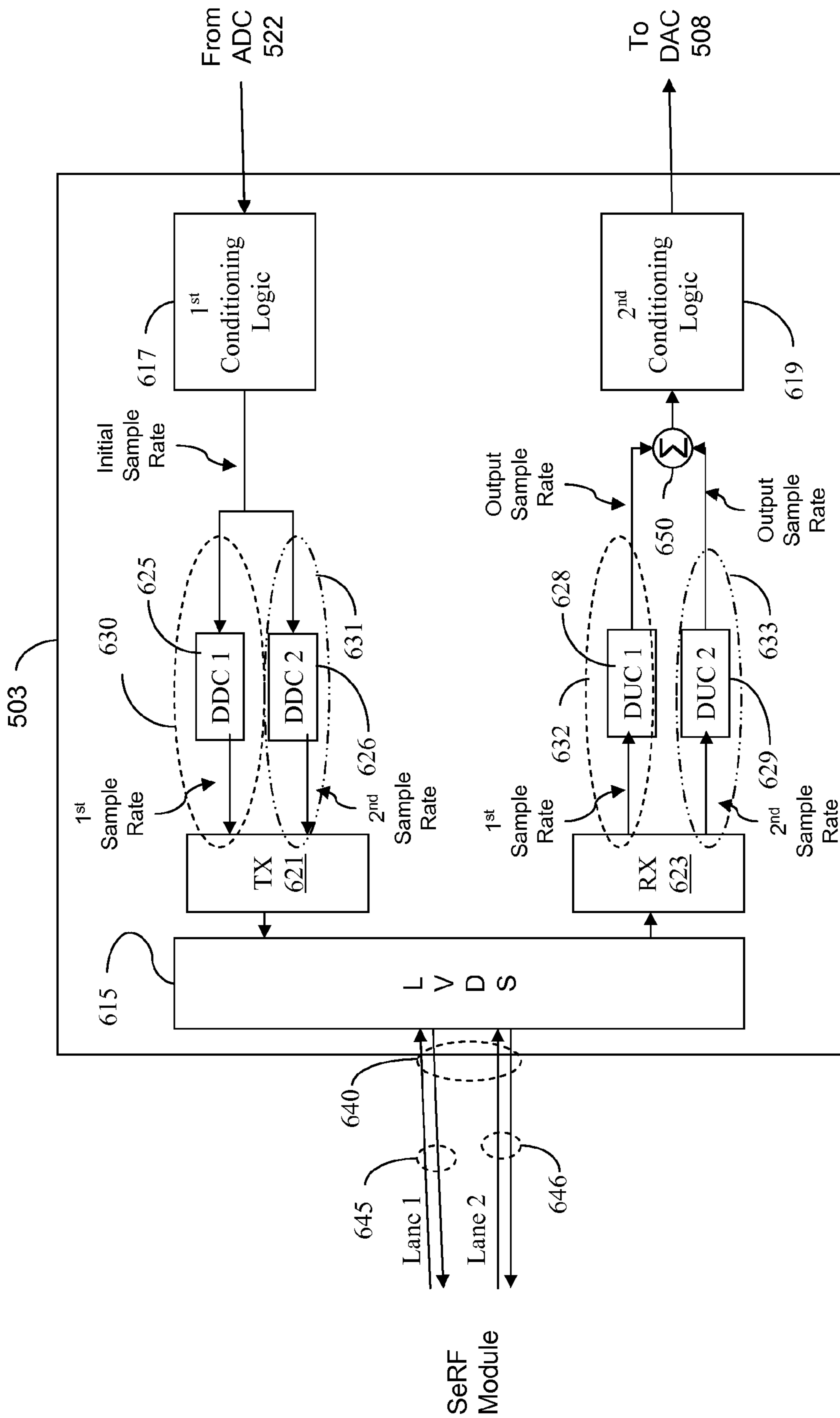

Fig. 6

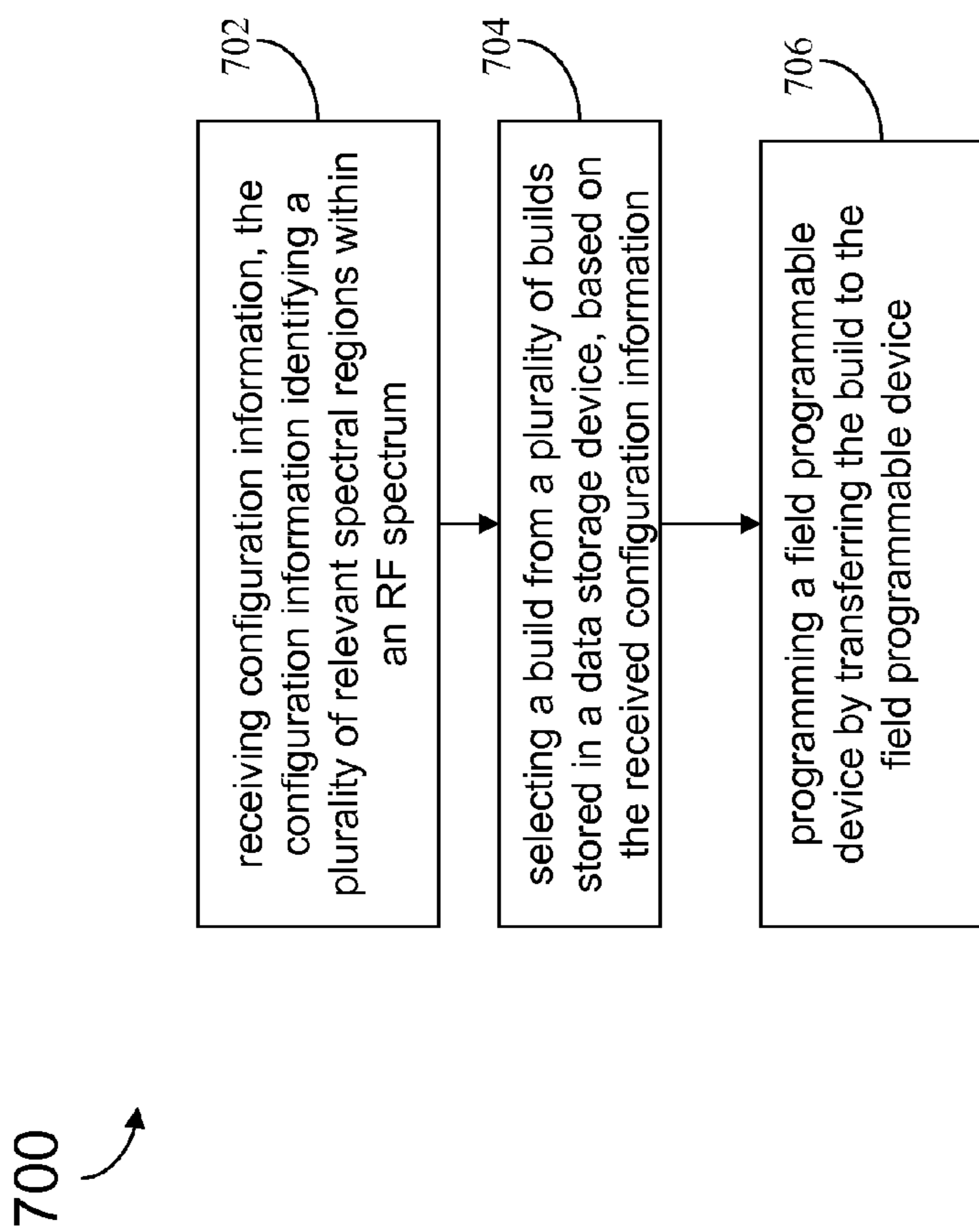

Fig. 7

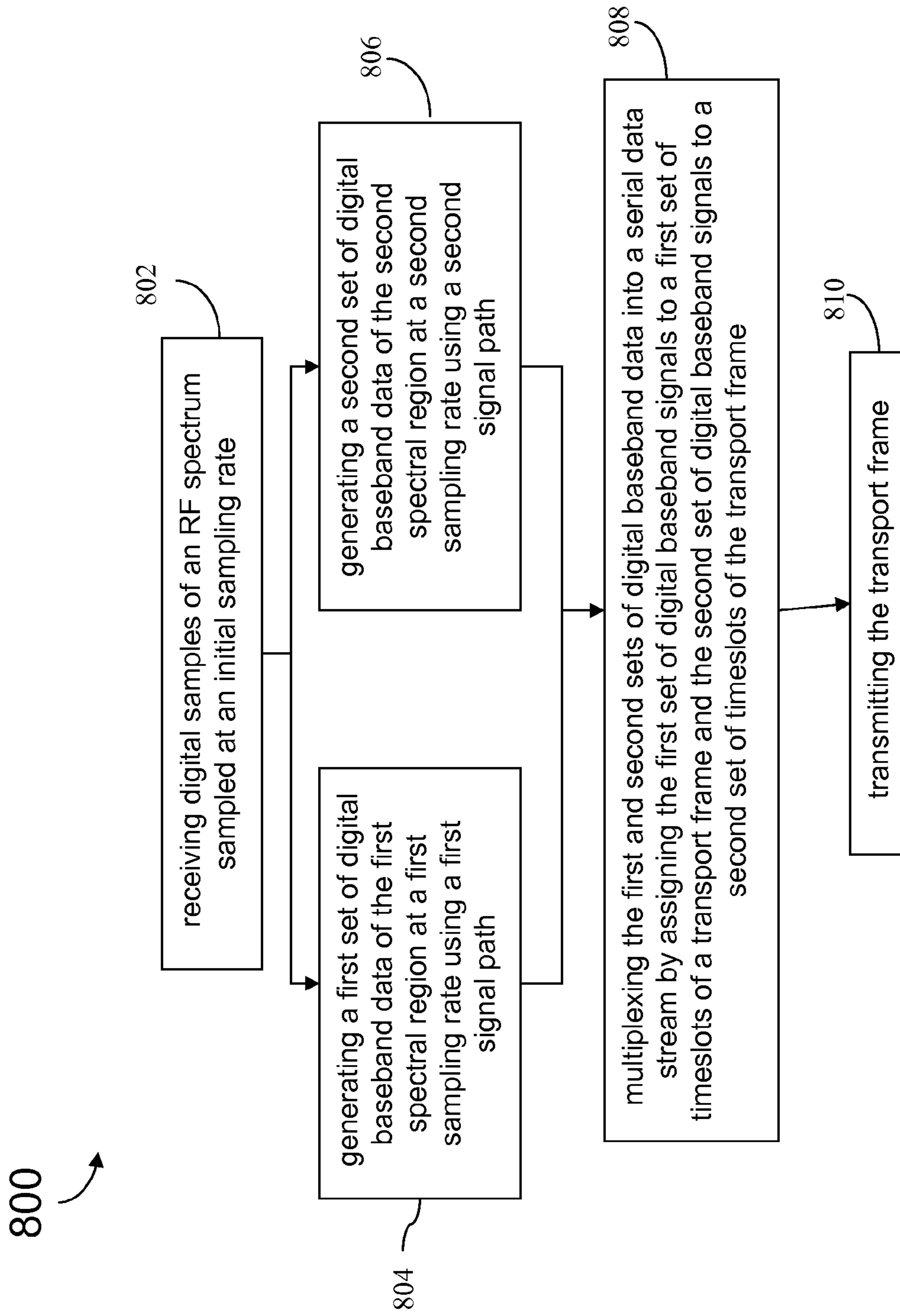

Fig. 8

900 ↗

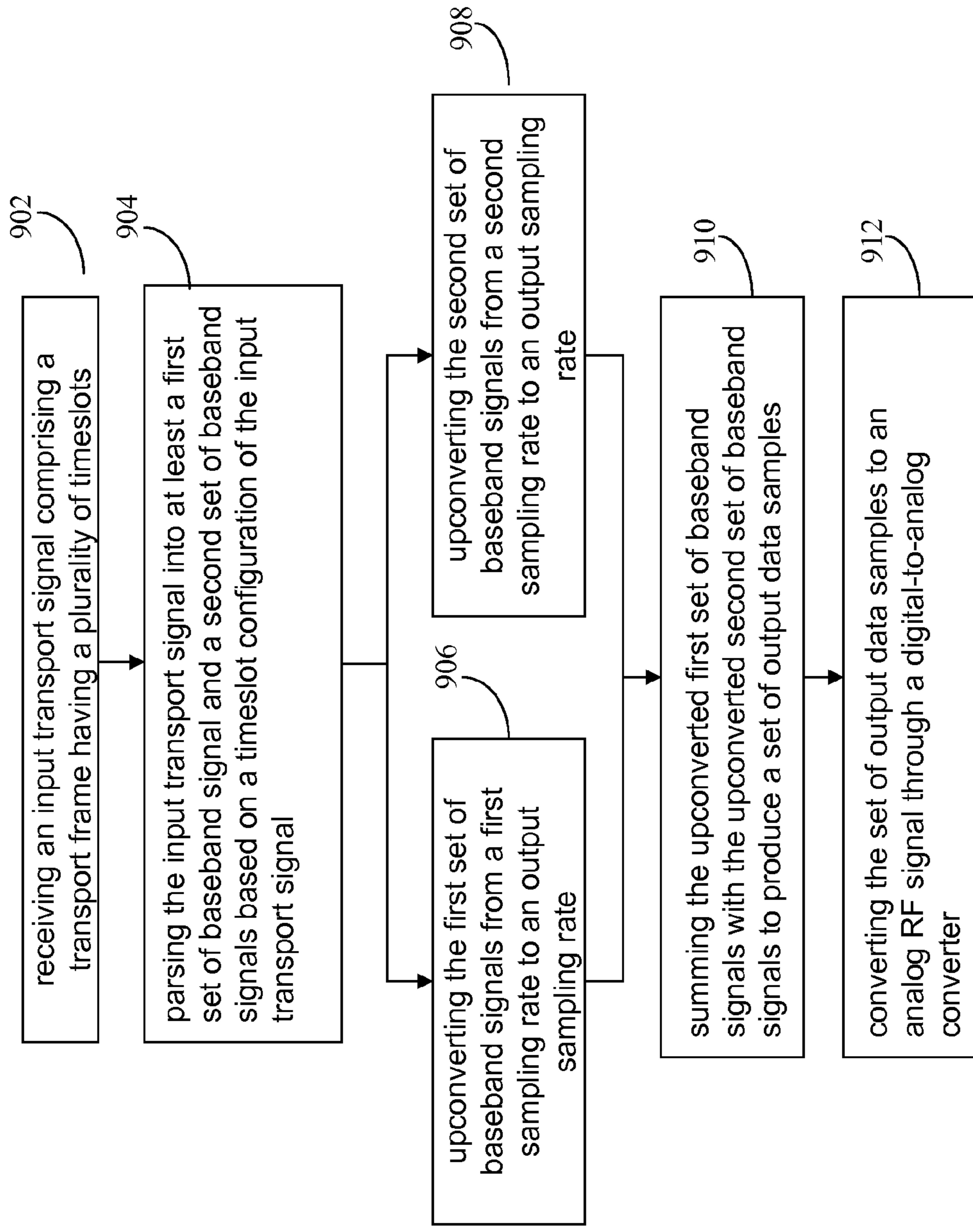

Fig. 9

**SYSTEMS AND METHODS FOR IMPROVED
DIGITAL RF TRANSPORT IN DISTRIBUTED
ANTENNA SYSTEMS**

Matter enclosed in heavy brackets [] appears in the original patent but forms no part of this reissue specification; matter printed in italics indicates the additions made by reissue; a claim printed with strikethrough indicates that the claim was canceled, disclaimed, or held invalid by a prior post-patent action or proceeding.

CROSS-REFERENCE TO RELATED
APPLICATIONS

This Reissue Application is a reissue of application Ser. No. 13/616,135, filed Sep. 14, 2012, which issued as U.S. Pat. No. 8,948,155. This application is a continuation of U.S. patent application No. 12/686,488, filed on Jan. 13, 2010, which claims the benefit of U.S. Provisional Application No. 61/144,349, filed on Jan. 13, 2009, both of which are incorporated herein by reference in their entirety.

BACKGROUND

A Distributed Antenna System (DAS) is a network of spatially separated antenna nodes connected to a common node via a transport medium that provides wireless service within a geographic area or structure. Common wireless communication system configurations employ a host unit as the common node, which is located at a centralized location (for example, at a facility that is controlled by a wireless service provider). The antenna nodes and related broadcasting and receiving equipment, located at a location that is remote from the host unit (for example, at a facility or site that is not controlled by the wireless service provider), are also referred to as "remote units." Radio frequency (RF) signals are communicated between the host unit and one or more remote units. In such a DAS, the host unit is typically communicatively coupled to one or more base stations (for example, via wired connection or via wireless connection) which allow bidirectional communications between wireless subscriber units within the DAS service area and communication networks such as, but not limited to, cellular phone networks, the public switch telephone network (PSTN) and the Internet. A DAS can provide, by its nature, an infrastructure within a community that can scatter remote units across a geographic area for providing wireless services across that area.

A digital DAS is a system wherein the host unit and remote units transport radio signal information to one another by digital means (for example, by digitally sampling a wireless radio frequency (RF) spectrum at a remote unit and transmitting the digital sample data to the host unit by fiber optics). One problem with the digital DAS occurs when radio signals of interest within the RF spectrum are separated by bandwidths containing no signals interest. In that case, fiber bandwidth within the digital DAS is wasted because all of the digital samples need to be transported at a rate sufficient to cover the full range of frequencies, not just the portions containing signals of interest.

For the reasons stated above and for other reasons stated below which will become apparent to those skilled in the art upon reading and understanding the specification, there is a need in the art for improved systems and methods for digital RF transport.

SUMMARY

Systems and methods for improved digital RF transport in a DAS are provided. In one embodiment, a transceiver comprises: a receive path circuit including an RF reception interface coupled to an ADC, the ADC receiving a down-converted analog RF spectrum from the RF reception interface and producing a digitized RF spectrum at an input sampling rate; a logic device receiving the digitized RF spectrum and producing a first set of baseband data samples at a first sampling rate, corresponding to a first spectral region of the analog RF spectrum and a second set of baseband data samples at a second sampling rate, corresponding to a second spectral region of the analog RF spectrum. The logic device maps the first set and second sets of baseband data samples to a respective first set and second set of timeslots of a serial data stream transport frame.

DRAWINGS

Understanding that the drawings depict only exemplary embodiments of the present invention and are not therefore to be considered limiting in scope, the exemplary embodiments will be described with additional specificity and detail through the use of the accompanying drawings, in which:

FIG. 1 is a block diagram of a distributed antenna system of one embodiment of the present invention;

FIG. 2 is a block diagram of a remote unit of one embodiment of the present invention;

FIG. 3 is a block diagram of a host unit of one embodiment of the present invention;

FIGS. 4A-4C illustrate mapping of RF spectral regions to transport frame timeslots, of one embodiment of the present invention;

FIG. 5 is a block diagram illustrating a DART Module of one embodiment of the present invention;

FIG. 6 is a block diagram illustrating an FPGA configuration for a DART Module of one embodiment of the present invention;

FIG. 7 is a flow chart illustrating a method of one embodiment of the present invention;

FIG. 8 is a flow chart illustrating a method of one embodiment of the present invention; and

FIG. 9 is a flow chart illustrating a method of one embodiment of the present invention.

In accordance with common practice, the various described features are not drawn to scale but are drawn to emphasize features relevant to the present invention. Reference characters denote like elements throughout figures and text.

DETAILED DESCRIPTION

Embodiments of the present invention address the problem of efficiently transporting multiple non-adjacent communications bands within the digital transport of a distributed antenna system. This is accomplished by segregating from a digitized RF spectrum a plurality of smaller spectral regions that include relevant signals of interest, and discarding information not within those spectral regions. This segregation further allows the spectral regions to be processed independently, and each independently re-sampled (at a sampling rate based on their respective bandwidths) so that they can be transmitted over a common serial transport link. Each spectral region is transmitted using a number of

timeslots in the serial bit stream that is a function of their respective bandwidths rather than the bandwidth of the entire digitized RF spectrum.

FIG. 1 is a block diagram of a distributed antenna system (DAS) 100 of one embodiment of the present invention for receiving and distributing radio frequency signals within a coverage area. DAS 100 includes a host unit 102 and a plurality of remote units 106. At the physical layer, host units 102 and remote units 106 are communicatively coupled via a communication link 130 to form a bidirectional communication network comprising a plurality of point-to-point communication links 130. In one embodiment, one or more of communication links 130 are fiber optic cable as indicated in FIG. 1. Optionally, host units 102 and remote units 106 may be interconnected via coaxial cable, or a combination of both coaxial cable and fiber optic cable. Additionally, in other embodiments, one or more of communication links 130 are wireless millimeter wave links (e.g. E Band/70 GHz radio). Here a millimeter signal transceiver is coupled to host unit 102 and each remote unit 106 on each end of communication link 130. In yet another embodiment, one or more of communication links 130 are microwave radio links where microwave radio transceivers are coupled to host unit 102 and remote units 106.

Remote units 106 each house electronic devices and systems used for wirelessly transmitting and receiving modulated radio frequency (RF) communications via antenna 107 with one or more mobile subscriber units 108. Host unit 102 is coupled to at least one base transceiver station (BTS) 110 often referred to as a base station. BTS 110 communicates voice and other data signals between the respective host unit 102 and a larger communication network via a gateway 124 coupled to a telephone system network 122 (for example, the public switched telephone network and/or wireless service provider networks) and an internet protocol (IP) network 120, such as the Internet. In one embodiment, DAS 100 comprises part of a cellular telephone network and subscriber units 108 are cellular telephones. In alternate embodiments, BTS 110 and host unit 102 may be interconnected via coaxial cable, fiber optic cable, wireless communication links, or any combination thereof.

Downlink RF signals are received from the BTS 110 at the host unit 102, which the host unit 102 uses to generate one or more downlink transport signals for transmitting to one or more of the remote units 106. Each such remote unit 106 receives at least one downlink transport and reconstructs the downlink RF signals from the downlink transport signal and causes the reconstructed downlink RF signals to be radiated from a remote antenna 107 coupled to or included in that remote unit 106. A similar process is performed in the uplink direction. Uplink RF signals received at one or more remote units 106 from subscriber 108 are used to generate respective uplink transport signals that are transmitted from the respective remote units 106 to the host unit 102. The host unit 102 receives and combines the uplink transport signals transmitted from the multiple remote units 106. The host unit 102 communicates the combined uplink RF signals to the BTS 110 over a broadband transport medium, such as a coaxial cable.

DAS 100 comprises a digital DAS transport meaning that the downlink and uplink transport signals transmitted between host unit 102 and remote units 106 over communication links 130 are generated by digitizing the downlink and uplink RF signals, respectively. In other words, the downlink and uplink transport signals are not analog RF signals but instead are digital data signals representing

digital RF samples of a modulated RF signal. These digital data signals, which may be alternately referred to herein as "digital RF", "digitally sampled RF" and "digital baseband", may comprise digital representations of an RF, IF or baseband version of the original RF signal. Further, these samples may be defined as real samples, or as pairs of complex (IQ or quadrature) samples. For example, if a particular communication signal destined for transmission to subscriber unit 108 is a modulated RF signal in the 900 MHz band, then host unit 102 will generate baseband digital samples of the modulated 900 MHz RF signal from BTS 110, which are then distributed by host unit 102 to the remote units 106. Alternatively, an all-digital BTS may generate baseband digital samples directly. At the remote units, the digital samples of the modulated RF signal are converted from digital into an analog RF signal to be wirelessly radiated from the antennas 107. In the uplink analog RF signals received at remote unit 106 are digitally sampled to generate digital RF data samples for the uplink transport signals. BTS 110, host unit 102 and remote units 106 each accommodate processing communication signals for multiple bands and multiple modulation schemes simultaneously. In the embodiment shown in FIG. 1, each remote unit 106 and host unit 102 comprises a digital to analog radio frequency transceiver (DART) module 132 configured to conserve the available bandwidth of the communication links 130 by separating and individually processing spectral regions of interest from a larger RF spectrum. More detail regarding the digital to analog radio frequency transceiver (DART) module 132 is provided below.

FIG. 2 is a block diagram of one embodiment of a remote unit 106. Remote unit 106 includes a serial radio frequency (SeRF) module 220, a digital to analog radio frequency transceiver (DART) module 208, a remote DART interface board (RDI) 224, and wireless RF components 250 that include electronics such as power amplifier, a duplexer, a low noise amplifier and other RF electronics coupled to an antenna 212. In alternate embodiments, SeRF modules and DART modules described herein are realized using FPGAs, ASICs, digital signal processing (DSP) boards, or similar devices.

DART module 208 provides bi-directional conversion between analog RF signals and digital sampled RF for the downlink and uplink transport signals transmitted between host unit 102 and remote units 106. In the uplink, antenna 212 receives a wireless RF signal from subscriber 208 and passes the RF signal to DART module 208 via RF components 250. DART module 208 receives an incoming analog RF signal spectrum and samples a predefined bandwidth of the incoming analog RF signal spectrum at a first sampling rate to generate digital data for use by SeRF module 220, as described below.

In the downlink, DART module 208 receives digitally sampled RF data from SeRF module 220, converts the digital RF samples to analog RF, and up converts the analog RF to a broadcast frequency for wireless transmission. After a signal is converted to an analog RF signal by DART module 208, the analog RF signal is sent to RF components 250 for broadcast via antenna 212. One of ordinary skill in the art upon reading this specification would appreciate that DART modules may function to optionally convert the digital RF samples into intermediate frequency (IF) samples instead of, or in addition to, baseband digital samples.

DART modules in a remote unit are specific for a particular frequency band. A single DART module operates over a defined frequency band regardless of the modulation technology being used. Thus frequency band adjustments in

a remote unit can be made by replacing a DART module covering one frequency band with a DART module covering a different frequency band. For example, in one implementation DART module 208 is designed to transmit 850 MHz cellular transmissions. As another example, in another implementation DART module 208 transmits 1900 MHz PCS signals. Some of the other options for a DART module 208 include Nextel 800 band, Nextel 900 band, PCS full band, PCS half band, BRS, and the European GSM 900, GSM 1800, and UMTS 2100. By allowing different varieties of DART modules 208 to be plugged into RDI 224, remote unit 106 is configurable to any of the above frequency bands and technologies as well as any new technologies or frequency bands that are developed.

SeRF module 220 provides bi-directional conversion between a digital data stream and a high speed optical serial data stream. In the uplink, SeRF module 220 receives incoming digital data streams from DART module 208 and sends a serial optical data stream over communication link 130 to host unit 102. In the downlink, SeRF module 202 receives an optical serial data stream from host unit 102 and provides a digital data stream to DART module 208. Although FIG. 2 illustrates a single DART module coupled to a SeRF module, a single remote unit housing may operate over multiple bands by possessing multiple DART modules. In one such embodiment, RDI 224 provides separate connection interfaces allowing each DART module to communicate RF data samples with SeRF module 220. In one embodiment a SeRF module actively multiplexes the signals from multiple DART modules (each DART module processing a different RF band) such that they are sent simultaneously over a single transport communication link 130.

FIG. 3 is a block diagram illustrating one embodiment of a host unit 102. Host unit 102 is communicatively coupled to multiple remote units 106 via the communication links 130, as described with respect to FIG. 1. Host unit 102 includes a host unit digital to analog radio frequency transceiver (DART) module 308 and a host unit serial radio frequency (SeRF) module 320. SeRF module 320 provides bi-directional conversion between digital RF data samples and the multiple high speed optical serial data streams to and from the remote units 106. In the uplink direction, SeRF module 320 receives incoming serial optical data streams from a plurality of remote units, extracts from each serial stream the digitized baseband RF data samples corresponding to each frequency band, and sums the multiple sample streams for each band into one composite stream of RF data samples for that band. DART module 308 provides a bi-directional interface between SeRF module 320 and one or more base stations, such as BTS 110. As with remote units 106, when host unit 320 operates over multiple bands with multiple base stations, a separate DART module 308 is provided for each frequency band.

As used herein, the terms Host SERF and Host DART refer to SeRF and DART modules located in a host unit 102. The terms Remote SeRF and Remote DART refer to SeRF and DART modules located in a remote unit 106.

FIG. 4A illustrates a digitized RF spectrum 400 that is processed by either a Host or Remote DART module of one embodiment of the present invention. In one embodiment, digitized RF spectrum 400 represents a digital sampling of an uplink analog signal received by a remote unit 106. In another embodiment, digitized RF spectrum 400 is instead a representation of a downlink signal received at a host unit 102 intended for wireless transmission by a remote unit 106. Within spectrum 400, spectral regions 451 and 452 both contain "relevant" RF signals. That is, the DART module

has been programmed to recognize that spectral regions 451 and 452 contain information to be transported over DAS 100. The first spectral region 451 includes a first bandwidth (BW1) while the second spectral region 452 includes a second bandwidth (BW2). The spectral region 450 corresponds to a non-relevant region of spectrum 400 that falls between regions 451 and 452. The DART module is thus not concerned with the transmission or reception of any signals within the non-relevant spectral region 450. However, embodiments comprising multiple DART modules are contemplated as within the scope of the present invention as mentioned above. In one such alternate embodiment of either a remote unit or a host unit, a region defined as non-relevant to a first DART module can be defined as a relevant spectral region to a second DART module.

FIG. 4B is a block diagram illustrating one embodiment of a mapping of digitized RF spectrum 400 onto timeslots of an N timeslot digital transport frame 460 carried over communication links 130. Spectral region 451 is processed by the DART module for transmission via digital transport frame 460 by re-sampling that portion of digitized RF spectrum 400 corresponding to spectral region 451. The re-sampling rate used will determine the number of timeslots that will be used to transport spectral region 451 and is based on the size of bandwidth BW1. For example, in one embodiment, three timeslots are required to transport a bandwidth of size BW1. Accordingly, timeslots TS1 (461), TS2 (462) and TS3 (463) are allocated for transporting the signals within spectral region 451.

Similarly, spectral region 451 is processed for transmission via digital transport frame 460 by re-sampling that portion of digitized RF spectrum 400 corresponding to spectral region 452 and is based on the bandwidth BW2. As would be apparent to one of ordinary skill in the art upon reading this specification, the first sampling rate used for re-sampling spectral region 451 will likely not be the same as the second sampling rate used for re-sampling spectral region 451, unless BW1 and BW2 are similar in size. Continuing the example, assuming that only one timeslot is required to transport a bandwidth of size BW2, timeslots TS4 (464) is allocated for transporting the signals within spectral region 452.

As shown by this example embodiment, the signals within the non-relevant spectral region 450 are not mapped onto digital transport frame 460. Thus, timeslots on digital transport frame 460 are not wasted on this non-relevant information and may be utilized for other purposes. For example, assuming that eight timeslots would otherwise be required to map the entire bandwidth of digitized RF spectrum 400 onto digital transport frame 460, the embodiment described above has reduced the number of timeslots needed by four by only mapping the relevant regions of spectrum 400. In this manner, fewer assigned time slots are required to accommodate the digital baseband data than would be if the digital baseband data were generated for the non-relevant spectral region 450. This results in bandwidth conservation in the DAS 100.

Although FIG. [2B] 4B illustrates spectral regions 451 and 452 mapped to adjacent timeslots of digital transport frame 460, embodiments of the present invention do not require adjacent mapping. For example, if TS4 (464) was allocated for use by a different DART module, or allocated for other purposes within the DAS 100, then TS5 or any other timeslot within digital transport frame 460 may be used to transport spectral region 352.

As would be apparent to one of ordinary skill in the art upon reading this specification, the number of distinct regions within a digitized RF spectrum is not limited to only two spectral regions. In other alternate embodiments, three or more spectral regions within a digitized RF spectrum may be defined as carrying relevant signals. The number of spectral regions that can be handled as discrete signal with a DART will be limited only by the limits of the implementing hardware.

For example, FIG. 4C illustrates a digitized RF spectrum 470 having four spectral regions 471, 472, 473 and 474, each containing signals defined as relevant. Regions 475, 476 and 477 are non-relevant regions. In one embodiment, each of the spectral regions 471, 472, 473 and 474 is individually re-sampled and mapped to timeslots based on their respective bandwidth sizes, as described above for FIG. 4A. In the case where the implementing hardware is not configured to re-sample and process four spectral regions separately, two or more of the spectral regions may be grouped together to define a single spectral region. For example, in FIG. 4C, where regions 471 and 472 contain relevant signals separated by a non-relevant region 475, the entire bandwidth including regions 471, 475 and 472 (shown generally as BW3) may be grouped together, re-sampled as a distinct slice of spectrum 470 and assigned to timeslots of frame 460 based on the size of BW3. Using the re-sampling and mapping scheme described in FIGS. 4A-C, a host unit 102 and the remote units 130 communicate RF transport signals that occupy less bandwidth of the communication links 130 as compared to presently existing schemes because time slots are not assigned for one or more non-relevant spectral regions.

FIG. 5 is a block diagram illustrating a DART Module 500 of one embodiment of the present invention. In alternate embodiments, DART Module 500 may operate as either a Host DART or a Remote DART module such as respective DART Modules 308 and 208. DART module 500 has two main signal paths; a transmission path 504 and a reception path 506. For signals received from a SeRF module, DART module 500 forms parallel digital RF data from the incoming data stream, if needed, at FPGA 503. In this embodiment, FPGA 503 is a logic device that is programmed to convert serial digital data into RF sampled data and programmed to convert RF sampled data into serial digital data. DART module 500 then converts the digital RF data to an analog signal with digital to analog converter (DAC) 508. Transmission path 504 continues with RF transmission interface 510 which filters, amplifies, and up-converts the analog signal for RF transmission. As would be readily appreciated by one of ordinary skill in the art upon reading this specification, RF transmission interface 510 will typically include an assortment of filters, amplifiers, oscillators and attenuators. In one embodiment, the transmission path exits DART module 500 at a subminiature version A RF coaxial connector (SMA) connector 520.

In the reception path 506, RF signals are converted from analog to digital and sent to the SeRF module. In one embodiment, analog RF signals are received at DART module 500 at an SMA connector 525. Reception path 506 includes an RF reception interface 530 that amplifies, down-converts, and filters the incoming RF signal. As would be readily appreciated by one of ordinary skill in the art upon reading this specification, RF reception interface 530 will typically include an assortment of filters, amplifiers, oscillators, and attenuators. After the RF reception interface 530, DART module 500 then digitizes the signal with analog to

digital converter 522. FPGA 503 then provides the data stream as parallel digital RF sampled data to a SeRF module.

FIG. 6 is a block diagram providing further details for FPGA 503 for one embodiment of the present invention. FPGA 503, for both the upstream and downstream directions, provides separate signal processing paths for each discrete spectral region of a digitized RF spectrum (such as 400 or 460) that is to be mapped onto timeslots of the transport frame 460. Although the FPGA 503 described in FIG. 6 illustrates an FPGA configured to process two discrete spectral regions in each direction (illustrated by first and second paths 630,631 in the receive direction and first and second paths 632,633 in the transmit direction), one of ordinary skill in the art after reading this specification would appreciate that the FPGA described in FIG. 6 may be scaled upward to include additional processing paths for three or more discrete spectral regions. This scaling is limited only by the particular constraints of the underlying hardware used (for example, the number of available gates provided by the FPGA hardware selected by the DART equipment designer).

In each direction, FPGA 503 provides a first path for processing digital signals associated with the radio frequency signals in a first spectral region (such as region 451 for example) and a second path for processing digital signals associated with the radio frequency signals in a second spectral region (such as region 452, for example). For processing the reception path 506, FPGA 503 includes first conditioning logic 617, a first digital down converter 625, a second digital down converter 626 and a transmitter (TX) 621. For processing the transmission path 504, FPGA 503 includes a receiver (RX) 623, a first digital up converter 628, a second digital up converter 629, summer 650, and second conditioning logic 619. FPGA 503 further includes a low-voltage differential signaling circuit 615 that facilitates communication between the transmission and receive paths (404, 406) and a SeRF module coupled to DART Module 500. In an alternate embodiment, the first conditioning logic 617 and the second conditioning logic 619 are realized using shared conditioning logic.

In the embodiment shown in FIG. 6, FPGA 503 is communicatively coupled to its associated SeRF Module by a bidirectional low-voltage differential signaling (LVDS) link 640. A first LVDS lane represented generally at 645 and a second LVDS lane represented generally at 646 are supported. In one implementation of this embodiment, first LVDS lane 645 and second LVDS lane 646 each transport digital baseband data at a 737.28 Mbps data rate. In this case, the first LVDS lane 645 and second LVDS lane 646 together transport digital baseband data at a 1474.56 Mbps data rate in up to six timeslots of a transport frame 460. In one embodiment, the link 640 runs at a fixed rate regardless of the payload (i.e., regardless of the number of time slots sent). One of ordinary skill in the art upon reading this specification would appreciate that in alternate embodiments of the present invention, the number of supported time slots is a design choice based on the number of timeslots supported by the particular hardware used.

In one embodiment of receive path 506, in operation, ADC 522 receives an analog RF spectrum from RF reception interface 530 and digitizes the complete analog RF spectrum using an initial sampling rate corresponding to the size of the bandwidth of the analog spectrum. The first conditioning logic 617 receives the digitized data samples from the analog-to-digital converter 522, and directs the digitized data samples to digital-down-converters (DDC) 625 and 626. The first digital down converter 625 and the

second digital down converter **626** each receive digitized data samples of the full RF spectrum.

The first and second digital down converters **625** and **626** are each configured to independently process distinct spectral regions of the sampled RF spectrum. Returning to the example of FIG. 4A, in one embodiment, first digital down converter **625** is programmed to filter out all signals except those in spectral region **451**. For example, in one embodiment, first digital down converter **625** is programmed with both the center frequency of the first spectral region **451** (shown as f_a) and the bandwidth BW1 of spectral region **451**. Digital down converter **625** thus applies a band-pass filter to the sampled RF spectrum, allowing only the data corresponding to the spectral region $f_{c1}-\frac{1}{2}(BW1)$ to $f_{c1}+\frac{1}{2}(BW1)$ to pass. Digital down converter **625** then converts the data corresponding to the first spectral region **451** into digital baseband signals by re-sampling the data from the initial sampling rate used to digitize the analog RF spectrum to a first sampling rate selected based on the size of BW1. The first sampling rate will determine the number of timeslots used to transport the digital baseband signals corresponding to spectral region **451**.

In the same way, second digital down converter **626** is programmed with both the center frequency of the second spectral region **454** (shown as f_{c2}) and the bandwidth BW2 of spectral region **452**. Digital down converter **626** then applies a band-pass filter to the sampled RF spectrum, allowing only the data corresponding to the spectral region $f_{c2}-\frac{1}{2}(BW2)$ to $f_{c2}+\frac{1}{2}(BW2)$ to pass. Digital down converter **626** then converts the data corresponding to the second spectral region **452** into digital baseband signals by re-sampling the data from the initial sampling rate used to digitize the analog RF spectrum to a second sampling rate selected based on the size of BW2. The second sampling rate will determine the number of timeslots used to transport the digital baseband signals corresponding to spectral region **452**.

Serialized transmitter (TX) **621** is positioned to receive the first set of digital baseband data samples from the first digital down converter **625** at the first sampling rate and the second set of baseband data sample from the second digital down converter **626** at the second sampling rate. Transmitter **621** multiplexes and serializes these two sets of baseband data into timeslots and provides the serialized data to the SeRF Module via the low-voltage differential signaling circuit **615**.

In one embodiment of transmit path **506**, in operation, DART Module **500** receives digital baseband data from the SeRF module via the low-voltage differential signaling circuit **615**. Serialized receiver **623** is positioned to receive serialized input from the low-voltage differential signaling circuit **615** and to direct data from timeslots associated with the first spectral region **451** to the first digital up converter **628**, and data from timeslots associated with the first spectral region **451** to the second digital up converter **629**. The first digital up converter **628** receives the data from timeslots associated with the first spectral region **451** at the first sampling rate and up-converts the baseband data by re-sampling the data from the first sampling rate to an output sampling rate. The second digital up converter **629** receives the data from timeslots associated with the second spectral region **452** at the second sampling rate and up-converts the baseband data by re-sampling the data from the second sampling rate to the same output sampling rate used by first digital up converter **628**. By upconverting both sets of baseband data to the same output sample rate, the up-converted data sample output from both digital upconverters

628, **629** can be readily summed together for further processing by DART Module **500** as a single data signal. Accordingly, summer **650** sums the upconverted data sample outputs from digital upconverters **628**, **629** and provides the summed signal to DAC **508** via 2^{nd} conditioning Logic **619**.

Because FPGA **503** is a field programmable device, it can be adjusted to meet changing needs of the end user. For example, the center frequencies f_{c1} and f_{c2} can be reprogrammed into FPGA **503** in order to shift the locations of spectral regions **451** and **452** within spectrum **400**. Similarly BW1 and BW2 may be adjusted to accommodate larger or narrower bandwidths. The number and/or position of timeslots within frame **460** provisioned for each discrete spectral region can also be reconfigured. As mentioned previously, the number of individual signal paths for handling additional spectral regions may be increased by configuring the FPGA with additional digital up converters and digital down converters. In one embodiment, a plurality of predefined configuration builds are stored in a memory, for example within a SeRF Module. In such an embodiment, a DART Module's FPGA can be reconfigured by pushing a new build image onto the FPGA.

FIG. 7 is a flow diagram a method **700** of one embodiment of the present invention. The method begins at **702** with receiving configuration information, the configuration information identifying a plurality of relevant spectral regions within an RF spectrum. In one embodiment, each relevant spectral region is identified by a center frequency and bandwidth. The relevant spectral regions are indicative of separate radio frequency bands of interest that are to be transported via a digital DAS. Configuration information can also information regarding the number and position of timeslots available for allocation to each spectral region. In one embodiment, the configuration information may be received via a user interface either directly or indirectly coupled to the DART module. The method proceeds to **704** with selecting a build from a plurality of builds stored in a data storage device, such as but not limited to a flash memory. Selection of the build is based on the received configuration information. The method proceeds to **706** with programming a field programmable device, such as an FPGA, by transferring the build to the field programmable device. Although the example of an FPGA has been used in this specification, other field programmable devices are contemplated as within the scope of embodiments of the present invention.

FIG. 8 is a flow chart illustrating a method **800** of one embodiment of the present invention. The method begins at **802** with receiving digital samples of an RF spectrum sampled at an initial sampling rate. The RF spectrum comprises a first spectral region that includes signals of interest and a second spectral region that includes signals of interest. In one embodiment, the first and second spectral regions are separated by a non-relevant spectral region. The method proceeds to **804** and **806**, which occur in parallel. At **804** the method proceeds with generating a first set of digital baseband data of the first spectral region at a first sampling rate using a first signal path. At **806** the method proceeds with generating a second set of digital baseband data of the second spectral region at a second sampling rate using a second signal path. As described above, the first sampling rate and the second sampling rate are determined from the bandwidths of the first spectral region and second spectral regions, respectively. The first signal path comprises a first digital down converter that filters the RF spectrum to pass only data signals corresponding to the first spectral region.

Those data signals are then re-sampled to the first sampling rate, which will determine the number of timeslots the first set of digital baseband data will occupy on the transport frame. The second signal path comprises a second digital down converter that filters the RF spectrum to pass only data signals corresponding to the second spectral region. Those data signals are then re-sampled to the second sampling rate, which will determine the number of timeslots the second set of digital baseband data will occupy on the transport frame.

The method then proceeds to **808** where the first and second sets of digital baseband data are multiplexed into a serial data stream by assigning the first set of digital baseband signals to a first set of timeslots of a transport frame and the second set of digital baseband signals to a second set of timeslots of the transport frame. The method proceeds to **810** with transmitting the transport frame. As would be appreciated by one of ordinary skill in the art, by processing the first and second spectral regions separately and at sample times corresponding to their respective bandwidths, the total number of timeslots necessary to transport the signals is less than if the entire received RF spectrum was converted to baseband and assigned to timeslots. In one embodiment, transmitting the transport frame comprises a SeRF Module transmitting the transport frame via an optical fiber. In the case where this method is implemented at a host unit, the transport frame is transmitted via the Host SeRF Module to a remote unit. In the case where this method is implemented at a remote unit, the transport frame is transmitted via the Remote SeRF Module to the host unit.

FIG. 9 is a flow diagram of a method **900** of one embodiment of the present. The method begins at **902** with receiving an input transport signal comprising a transport frame having a plurality of timeslots. The method proceeds to **904** with parsing the input transport signal into at least a first set of baseband signal and a second set of baseband signals based on a timeslot configuration of the input transport signal. In one embodiment, demultiplexing logic in the low-voltage differential signaling circuit parses the input stream and sends the baseband data to either a first digital up converter or second digital up converter based on the timeslot configuration. The method then proceeds to blocks **906** and **908**, which run in parallel.

At block **906**, the method proceeds with upconverting the first set of baseband signals from a first sampling rate to an output sampling rate. At block **908** the method proceeds with upconverting the second set of baseband signals from a second sampling rate to an output sampling rate. By upconverting both sets of baseband data to the same output sample rate, the up-converted data sample output from both digital upconverters can be readily summed together into a single signal of data samples. Accordingly, the method proceeds to **910** with summing the upconverted first set of baseband signals with the upconverted second set of baseband signals to produce a set of output data samples. The method then proceeds to **912** with converting the set of output data samples to an analog RF signal through a digital-to-analog converter.

Although specific embodiments have been illustrated and described herein, it will be appreciated by those of ordinary skill in the art that any arrangement, which is calculated to achieve the same purpose, may be substituted for the specific embodiment shown. This disclosure is intended to cover any adaptations or variations of the present invention. Therefore, it is manifestly intended that this invention be limited only by the claims and the equivalents thereof.

What is claimed is:

1. A communication device for providing digital transport of signals in a distributed antenna system, the communication device comprising:

a reception path circuit configured to output digitized radio frequency spectrum at an input sampling rate based on input signals;

a transmission path circuit configured to output signals based on received digitized radio frequency spectrum;

a logic device coupled to the reception path circuit and configured to receive digitized radio frequency spectrum at the input sampling rate from the reception path circuit, the logic device further configured to produce a first plurality of sets of digitized baseband data samples at a plurality of sampling rates, each set of digitized baseband data samples corresponding to a distinct spectral region of the analog radio frequency spectrum; **[and]**

wherein the logic device is further configured to map each of the first plurality of sets of digitized baseband data samples to a set of timeslots of a serial data stream transport frame;

the logic device further coupled to the transmission path circuit, the logic device configured to receive an input transport frame having a plurality of sets of timeslots, wherein each of the set of timeslots includes a second set of digitized baseband data samples at one of the plurality of sampling rates, the set of digitized baseband data samples for each set of timeslots corresponding to one of the distinct spectral regions of the analog radio frequency spectrum;

wherein the logic device is configured to generate a second plurality of sets of digitized data samples for each set of the timeslots at an output sampling rate; and wherein the logic device sums at least two of the second plurality of sets of digitized data samples to produce a set of output data samples at the output sampling rate.

2. The communication device of claim **1**, wherein the reception path circuit is configured to receive baseband digital samples from another device; and

wherein the reception path circuit is configured to output the digitized radio frequency spectrum based on the baseband digital samples.

3. The communication device of claim **1**, wherein the reception path circuit is configured to receive baseband digital samples directly from a base transceiver station; and wherein the reception path circuit is configured to output the digitized radio frequency spectrum based on the baseband digital samples received directly from the base transceiver station.

4. The communication device of claim **1**, wherein the reception path circuit includes a radio frequency reception interface coupled to an analog-to-digital converter, the analog-to-digital converter configured to receive down-converted analog radio frequency spectrum from the radio frequency reception interface, the analog-to-digital converter further configured to produce digitized radio frequency spectrum at an input sampling rate.

5. The communication device of claim **1**, wherein each of the set of timeslots consists of a corresponding number of timeslots based on a bandwidth of the distinct spectral region corresponding with the set of timeslots.

6. The communication device of claim **1**, wherein the analog radio frequency spectrum comprises non-relevant spectral regions that are not mapped onto any of the set of timeslots of the serial data stream transport frame.

13

7. The communication device of claim 1, the logic device including a plurality of down converters operating in parallel and receiving digitized radio frequency spectrum at the input sampling rate; and

wherein each digital down converter is configured to convert data corresponding to a corresponding distinct spectral region into the corresponding set of digitized baseband data samples at the corresponding sampling rate, wherein the corresponding sampling rate is a function of a size of a bandwidth of the corresponding distinct spectral region.

8. The communication device of claim 7, the logic device further comprising a serialized transmitter configured to transmit the first plurality of sets of digitized baseband data samples at the corresponding sampling rates; and

the serialized transmitter further configured to map the first plurality of sets of digitized baseband data samples to the corresponding sets of timeslots.

9. The communication device of claim 1, wherein the first plurality of sets of digitized baseband data samples includes at least three sets of digitized baseband data samples corresponding to at least three distinct spectral regions; and

wherein the set of timeslots includes at least three timeslots.

[10. The communication device of claim 1, further comprising:

a transmission path circuit configured to output signals based on received digitized radio frequency spectrum; the logic device further coupled to the transmission path circuit, the logic device configured to receive an input transport frame having a plurality of sets of timeslots, wherein each of the set of timeslots includes a second set of digitized baseband data samples at one of the plurality of sampling rates, the set of digitized baseband data samples for each set of timeslots corresponding to one of the distinct spectral regions of the analog radio frequency spectrum;

wherein the logic device is configured to generate a second plurality of sets of digitized data samples for each set of the timeslots at an output sampling rate; and wherein the logic device sums at least two of the second plurality of sets of digitized data samples to produce a set of output data samples at the output sampling rate.]

11. The communication device of claim 1, wherein the logic [circuit] device comprises a field programmable device.

12. The communication device of claim 1, wherein the spectral regions are user selectable from a plurality of pre-built logic circuit configurations.

13. The communication device of claim 1, wherein a center frequency and bandwidth size that define the first spectral bandwidth are user reconfigurable.

14. A communication device for providing digital transport of signals in a distributed antenna system, the communication device comprising: a transmission path circuit configured to output signals based on received digitized radio frequency spectrum; a logic device coupled to the transmission path circuit and configured to receive an input transport frame having a plurality of sets of timeslots, wherein each set of timeslots includes a first plurality of sets of digitized baseband data samples at one of the plurality of sampling rates, the set of digitized baseband data samples for each set of timeslots corresponding to a distinct spectral region of analog radio frequency spectrum; wherein the logic device is configured to generate second plurality of sets of digitized data samples for each set of the timeslots at an output sampling rate; and wherein the logic device sums at least

14

two of the second plurality of sets of digitized data samples to produce a set of output data samples at the output sampling rate.

15. The communication device of claim 14, wherein the logic device is configured to generate the second plurality of sets of digitized data samples by up-converting the first plurality of sets of digitized baseband data samples to distinct spectral regions at the output sampling rate.

16. The communication device of claim 14, wherein the transmission path circuit is configured to transmit baseband digital samples to another device; and

wherein the transmission path circuit is configured to transmit the output data samples.

17. The communication device of claim 14, wherein the transmission path circuit is configured to transmit baseband digital samples directly to a base transceiver station; and

wherein the transmission path circuit is configured to transmit the output data samples directly to the base transceiver station.

18. The communication device of claim 14, wherein the transmission path circuit includes a radio frequency transmission interface coupled to a digital-to-analog converter, the digital-to-analog converter configured to receive output data samples at the output sampling rate and configured to generate an output analog signal from the output data samples; and

wherein the radio frequency transmission interface receives the output analog signal and up-converts the output analog signal into an analog radio frequency signal within the analog radio frequency spectrum.

19. The communication device of claim 14, the logic device including a plurality of digital up converters operating in parallel and configured to receive the second plurality of sets of digitized data samples and convert the second plurality of sets of digitized data samples into the analog radio frequency signal in the analog radio frequency spectrum.

20. The communication device of claim 19, the logic device further comprising a serialized receiver receiving the input transport frame and parsing timeslots of the transport frame to the plurality of digital up converters based on a timeslot configuration of the input transport frame.

21. The communication device of claim 14, wherein the analog radio frequency spectrum comprises non-relevant spectral regions that are not mapped to any of the set of timeslots of the serial data stream transport frame.

22. The communication device of claim 14, the logic device including a plurality of down converters operating in parallel and receiving digitized radio frequency spectrum at the input sampling rate; and

wherein each digital down converter is configured to convert data corresponding to a corresponding spectral region into the corresponding set of digitized baseband data samples at the corresponding sampling rate, wherein the corresponding sampling rate is a function of a size of a bandwidth of the corresponding spectral region.

23. The communication device of claim 14, wherein the plurality of sets of digitized baseband data samples includes at least three sets of digitized baseband data samples corresponding to at least three spectral regions; and

wherein the set of timeslots includes at least three timeslots.

[24. The communication device of claim 14, further comprising:

a reception path circuit configured to output digitized radio frequency spectrum;

15

a logic device coupled to the reception path circuit and configured to receive digitized radio frequency spectrum at an input sampling rate from the reception path circuit, the logic device further configured to produce a second plurality of sets of digitized baseband data samples at a plurality of sampling rates, each set of digitized baseband data samples corresponding to a spectral region of the analog radio frequency spectrum; and

wherein the logic device is further configured to map each set of digitized baseband data samples to the set of timeslots of the serial data stream transport frame.]

25. A method for providing digital transport of signals in a distributed antenna system, the method comprising:

multiplexing a plurality of sets of digitized baseband signals into a serial data stream by assigning each set of digitized baseband signals to a corresponding timeslot of a transport frame, wherein each of the plurality of sets of digitized baseband signals corresponds to a distinct spectral region of radio frequency spectrum, wherein each of the plurality of sets of digitized baseband signals has a corresponding sampling rate; [and] transmitting the transport frame;

receiving an input transport signal comprising a transport frame having a plurality of timeslots;

parsing the input transport signal into a plurality of sets of digitized baseband signals based on a timeslot configuration of the input transport signal;

converting the plurality of sets of digitized baseband signals from first sampling rates to an output sampling rate; and

summing at least two of the plurality of sets of digitized baseband signals to produce a set of output data samples.

26. The method of claim 25, further comprising: receiving digital samples of analog radio frequency spectrum sampled at an initial sampling rate; and generating the plurality of sets of digitized baseband signals in parallel based on the received digital samples of analog radio frequency spectrum.

27. The method of claim 25, wherein generating each set of digitized baseband signals comprises filtering the received digital samples of the analog radio frequency spectrum to pass only digital samples corresponding to the distinct spectral region corresponding to the set of digitized baseband signals.

28. The method of claim 25, wherein the first plurality of sets of digitized baseband signals includes at least three sets of digitized baseband signals corresponding to at least three spectral regions.

29. The method of claim 25, further comprising: receiving configuration information, the configuration information identifying a plurality of relevant spectral regions within the radio frequency spectrum; selecting a build from a plurality of builds stored in a data storage device based on the configuration information; and

programming a field programmable device by transferring the build to the [filed] field programmable device.

30. The method of claim 29, wherein the configuration information identifies a center frequency and bandwidth size for defining the first spectral region.

31. A method for providing digital transport of signals in a distributed antenna system, the method comprising:

receiving an input transport signal comprising a transport frame having a plurality of timeslots;

16

parsing the input transport signal into a plurality of sets of digitized baseband signals based on a timeslot configuration of the input transport signal;

converting the plurality of sets of digitized baseband signals from first sampling rates to an output sampling rate; and

summing at least two of the plurality of sets of digitized baseband signals to produce a set of output data samples.

32. The method of claim 31, further comprising: converting the set of output data samples to an analog radio frequency signal through a digital-to-analog converter.

33. The method of claim 31, wherein converting the plurality of sets of baseband signals further comprising generating a plurality of sets of radio frequency samples corresponding to a first spectral region of analog radio frequency spectrum.

34. The method of claim 31, wherein the first plurality of sets of digitized baseband signals includes at least three sets of digitized baseband signals corresponding to at least three spectral regions.

35. The method of claim 31, further comprising: receiving configuration information identifying a plurality of relevant spectral regions within the analog radio frequency spectrum;

selecting a build from a plurality of builds stored in a data storage device based on the configuration information; and

programming a field programmable device by transferring the build to the field programmable device.

36. The method of claim 35, wherein the configuration information identifies a center frequency and bandwidth size for defining the first spectral region.

37. A communication device for providing digital transport of signals in a distributed antenna system, the communication device comprising:

a first circuit configured to output at least one digital signal indicative of radio frequency spectrum at a first sample rate based on first signals;

a transmission path circuit configured to output signals based on received at least one digital signal indicative of radio frequency spectrum;

a logic device associated with the first circuit and configured to use the at least one digital signal indicative of radio frequency spectrum at the first sample rate from the first circuit to produce a first plurality of sets of digital baseband data samples, each set of digitized baseband samples having a sample rate, each set of digital baseband data samples corresponding to a distinct spectral region of radio frequency spectrum; wherein the communication device is configured to map each of the first plurality of sets of digital baseband data samples to a respective portion of a transport frame;

the logic device further associated with the transmission path circuit, the logic device configured to receive an input transport frame having a plurality of sets of timeslots, wherein each of the respective portion includes a second set of digital baseband data samples at one of the plurality of sample rates, the set of digital baseband data samples for each respective portion corresponding to one of the distinct spectral regions of the radio frequency spectrum;

wherein the logic device is configured to generate a second plurality of sets of digitized data samples for each set of the timeslots at an output sample rate; and

wherein the logic device sums at least two of the second plurality of sets of digitized data samples to produce a set of output data samples at the output sample rate.

38. The communication device of claim 37, wherein the first circuit is configured to receive baseband digital samples from another device; and

wherein the first circuit is configured to output the at least one digital signal indicative of radio frequency spectrum based on the baseband digital samples.

39. The communication device of claim 37, wherein the first circuit is configured to receive baseband digital samples directly from a base transceiver station; and

wherein the first circuit is configured to output the at least one digital signal indicative of radio frequency spectrum based on the baseband digital samples received directly from the base transceiver station.

40. The communication device of claim 37, wherein the first circuit includes a radio frequency reception interface associated with an analog-to-digital converter, the analog-to-digital converter configured to receive down-converted radio frequency spectrum from the radio frequency reception interface, the analog-to-digital converter further configured to produce the at least one digital signal indicative of radio frequency spectrum at the first sample rate.

41. The communication device of claim 37, wherein each of the respective portion consists of a corresponding number of timeslots based on a bandwidth of the distinct spectral region corresponding with the respective portion.

42. The communication device of claim 37, wherein the radio frequency spectrum comprises non-relevant spectral regions that are not mapped onto any of the respective portion of the transport frame.

43. The communication device of claim 37, the logic device including a plurality of down converters operating in parallel and receiving at least one digital signal indicative of radio frequency spectrum at the first sample rate; and

wherein each digital down converter is configured to convert data corresponding to a corresponding distinct spectral region into the corresponding set of digital baseband data samples at the corresponding sample rate, wherein the corresponding sample rate is a function of a size of a bandwidth of the corresponding distinct spectral region.

44. The communication device of claim 43, the logic device further comprising a serialized transmitter configured to transmit the first plurality of sets of digital baseband data samples at the corresponding sample rates; and

the serialized transmitter further configured to map the first plurality of sets of digital baseband data samples to the corresponding sets of timeslots.

45. The communication device of claim 37, wherein the first plurality of sets of digital baseband data samples includes at least three sets of digital baseband data samples corresponding to at least three distinct spectral regions; and

wherein the respective portion includes at least three timeslots.

46. The communication device of claim 37, wherein the logic device comprises a field programmable device.

47. The communication device of claim 37, wherein the spectral regions are user selectable from a plurality of pre-built logic circuit configurations.

48. The communication device of claim 37, wherein a center frequency and bandwidth size that define the first spectral bandwidth are user reconfigurable.

49. A communication device for providing digital transport of signals in a distributed antenna system, the communication device comprising:

a transmission path circuit configured to output signals based on received at least one digital signal indicative of radio frequency spectrum;

a logic device associated with the transmission path circuit and configured to receive an input transport frame having a plurality of sets of timeslots, wherein each respective portion includes a first plurality of sets of digital baseband data samples at one of a plurality of sample rates, the set of digital baseband data samples for each respective portion corresponding to a distinct spectral region of radio frequency spectrum; wherein the logic device is configured to generate a second plurality of sets of digitized data samples for each set of the timeslots at an output sample rate; and wherein the logic device sums at least two of the second plurality of sets of digitized data samples to produce a set of output data samples at the output sample rate.

50. The communication device of claim 49, wherein the logic device is configured to generate the second plurality of sets of digitized data samples by up-converting the first plurality of sets of digital baseband data samples to distinct spectral regions at the output sample rate.

51. The communication device of claim 49, wherein the transmission path circuit is configured to transmit baseband digital samples to another device; and

wherein the transmission path circuit is configured to transmit the output data samples.

52. The communication device of claim 49, wherein the transmission path circuit is configured to transmit baseband digital samples directly to a base transceiver station; and wherein the transmission path circuit is configured to transmit the output data samples directly to the base transceiver station.

53. The communication device of claim 49, wherein the transmission path circuit includes a radio frequency transmission interface associated with a digital-to-analog converter, the digital-to-analog converter configured to receive output data samples at the output sample rate and configured to generate an output analog signal from the output data samples; and

wherein the radio frequency transmission interface receives the output analog signal and up-converts the output analog signal into a radio frequency signal within the radio frequency spectrum.

54. The communication device of claim 49, the logic device including a plurality of digital up converters operating in parallel and configured to receive the second plurality of sets of digitized data samples and convert the second plurality of sets of digitized data samples into the radio frequency signal in the radio frequency spectrum.

55. The communication device of claim 54, the logic device further comprising a serialized receiver receiving the input transport frame and parsing timeslots of the transport frame to the plurality of digital up converters based on a timeslot configuration of the input transport frame.

56. The communication device of claim 49, wherein the radio frequency spectrum comprises non-relevant spectral regions that are not mapped to any of the respective portion of the transport frame.

57. The communication device of claim 49, the logic device including a plurality of down converters operating in parallel and receiving at least one digital signal indicative of radio frequency spectrum at the first sample rate; and

wherein each digital down converter is configured to convert data corresponding to a corresponding spectral region into the corresponding set of digital baseband data samples at the corresponding sample rate,

wherein the corresponding sample rate is a function of a size of a bandwidth of the corresponding spectral region.

58. The communication device of claim 49, wherein the plurality of sets of digital baseband data samples includes at least three sets of digital baseband data samples corresponding to at least three spectral regions; and wherein the respective portion includes at least three timeslots.

59. The communication device of claim 49, further comprising:

a first circuit configured to output at least one digital signal indicative of radio frequency spectrum;
the logic device associated with the first circuit and configured to use the at least one digital signal indicative of radio frequency spectrum at a first sample rate from the first circuit, the logic device further configured to produce a second plurality of sets of digital baseband data samples at a plurality of sample rates, each set of digital baseband data samples corresponding to a spectral region of the radio frequency spectrum; and wherein the logic device is further configured to map each set of digital baseband data samples to the respective portion of the transport frame.

* * * * *