



US00RE48082E

(19) **United States**  
(12) **Reissued Patent**  
**Castonguay et al.**

(10) **Patent Number:** **US RE48,082 E**  
(45) **Date of Reissued Patent:** **\*Jul. 7, 2020**

(54) **FIBER OPTIC LOCAL CONVERGENCE POINTS FOR MULTIPLE DWELLING UNITS**

(58) **Field of Classification Search**  
CPC ..... G02B 6/445; G02B 6/4452; G02B 6/4471  
See application file for complete search history.

(71) Applicant: **Corning Optical Communications LLC**, Hickory, NC (US)

(56) **References Cited**

(72) Inventors: **Guy Castonguay**, Peoria, AZ (US);  
**Terry Dean Cox**, Fort Worth, TX (US);  
**Thomas Shaw Liggett**, Keller, TX (US);  
**Selena Strickland**, Monclova, OH (US)

U.S. PATENT DOCUMENTS

4,792,203 A 12/1988 Nelson et al.  
4,844,573 A \* 7/1989 Gillham et al. .... 385/42  
(Continued)

(73) Assignee: **Corning Optical Communications LLP**, Hickory, NC (US)

FOREIGN PATENT DOCUMENTS

CN 1632628 A 6/2005  
CN 1300607 C 2/2007  
(Continued)

(\*) Notice: This patent is subject to a terminal disclaimer.

OTHER PUBLICATIONS

(21) Appl. No.: **15/715,694**

Patent Cooperation Treaty, International Search Report and Written Opinion for International Application No. PCT/US2008/03128, dated Feb. 7, 2008.

(22) Filed: **Sep. 26, 2017**

(Continued)

**Related U.S. Patent Documents**

Reissue of:

(64) Patent No.: **7,548,680**  
Issued: **Jun. 16, 2009**  
Appl. No.: **12/012,144**  
Filed: **Jan. 31, 2008**

*Primary Examiner* — Deandra M Hughes

(74) *Attorney, Agent, or Firm* — Pepper Hamilton LLP

U.S. Applications:

(63) Continuation of application No. 13/162,115, filed on Jun. 16, 2011, now Pat. No. Re. 46,701, which is an application for the reissue of Pat. No. 7,548,680, which is a continuation of application No. 11/653,137, filed on Jan. 12, 2007, now Pat. No. 7,349,616.

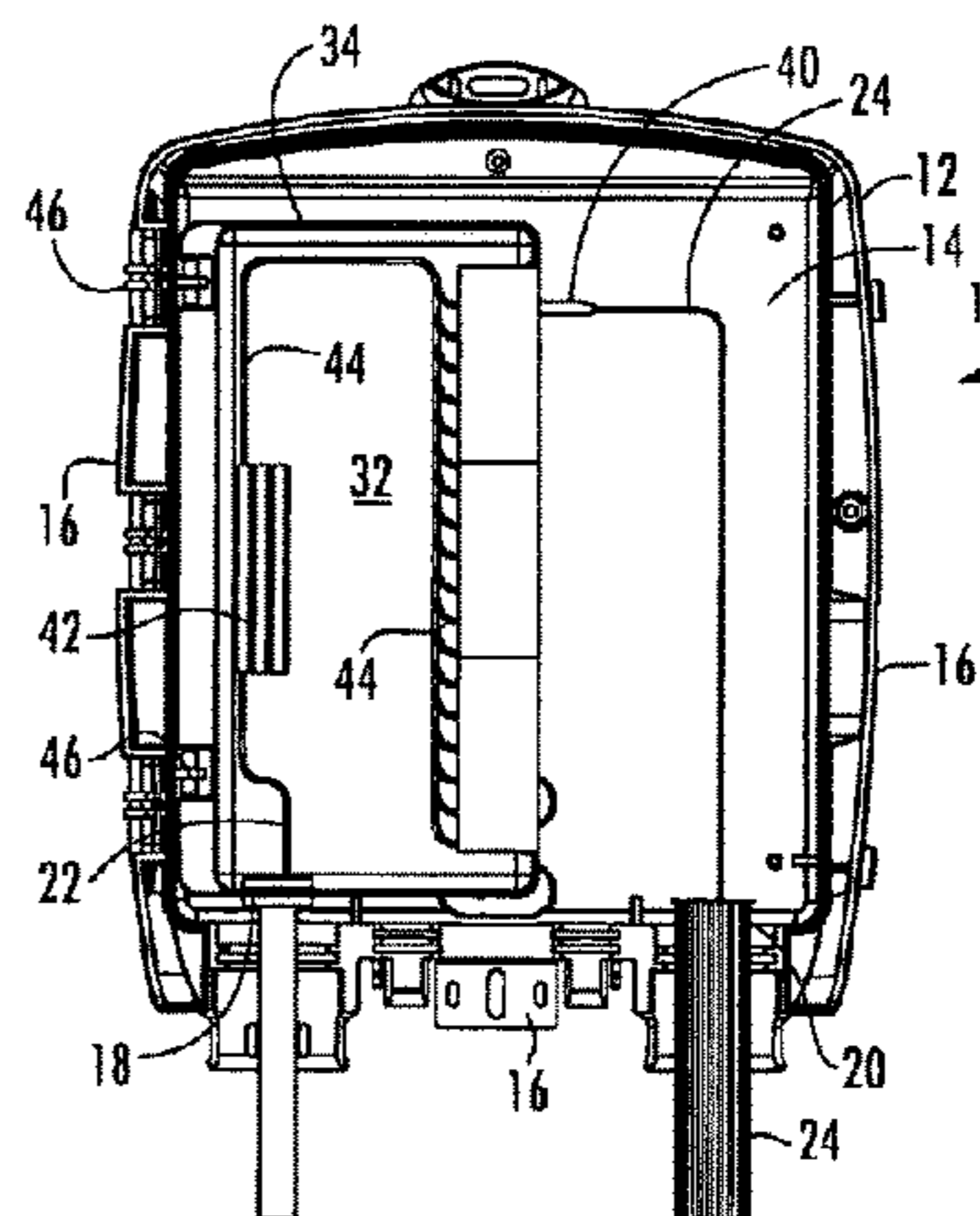
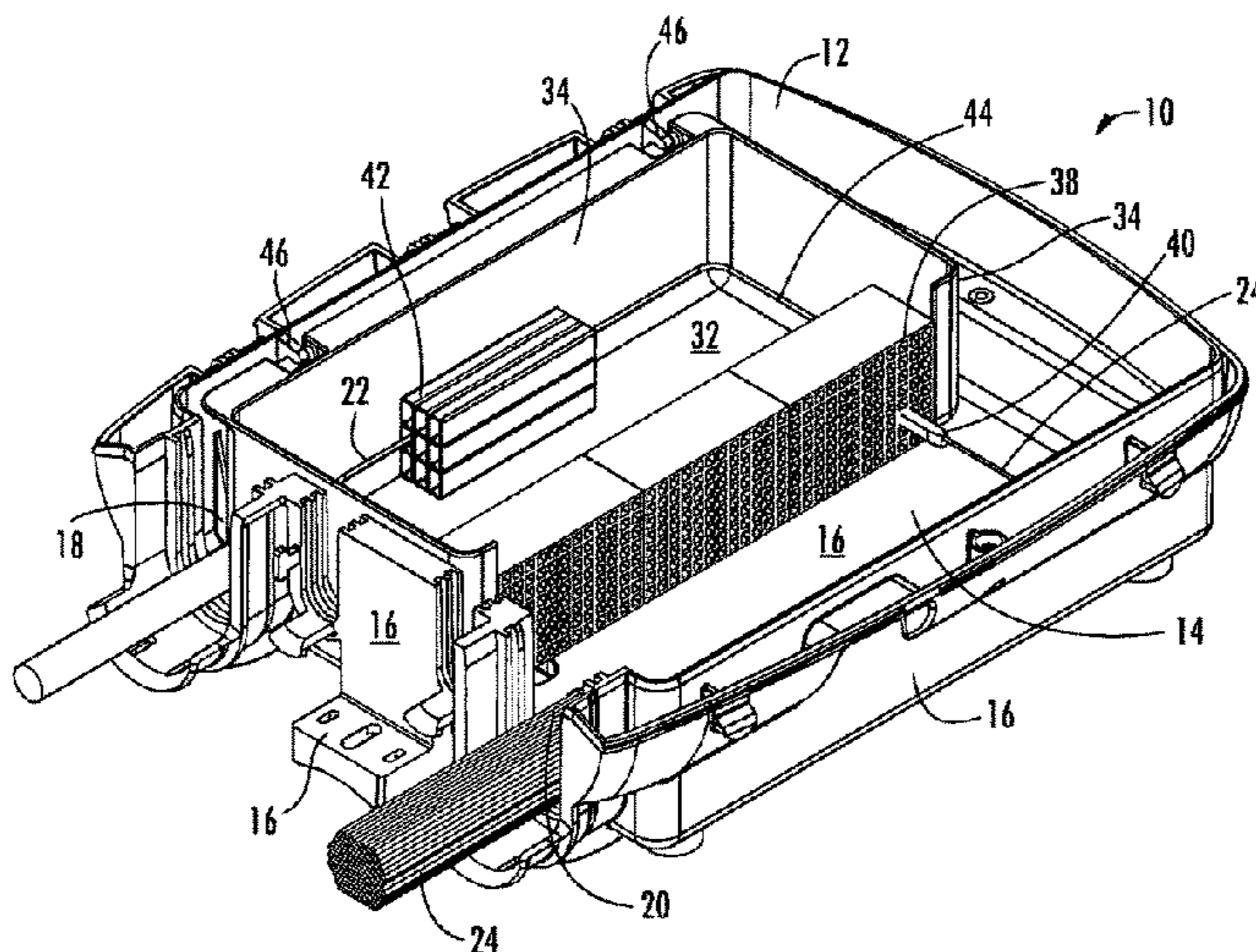
(57) **ABSTRACT**

There are provided fiber optic local convergence points (“LCPs”) adapted for use with multiple dwelling units (“MDUs”) that facilitate relatively easy installation and/or optical connectivity to a relatively large number of subscribers. The LCP includes a housing mounted to a surface, such as a wall, and a cable assembly with a connector end to be optically connected to a distribution cable and a splitter end to be located within the housing. The splitter end includes at least one splitter and a plurality of subscriber receptacles to which subscriber cables may be optically connected. The splitter end of the cable assembly of the LCP may also include a splice tray assembly and/or a fiber optic routing guide. Furthermore, a fiber distribution terminal (“FDT”) may be provided along the subscriber cable to facilitate installation of the fiber optic network within the MDU.

(51) **Int. Cl.**  
**G02B 6/00** (2006.01)  
**H04J 14/00** (2006.01)  
**G02B 6/44** (2006.01)

(52) **U.S. Cl.**  
CPC ..... **G02B 6/445** (2013.01); **G02B 6/4452** (2013.01); **G02B 6/4454** (2013.01); **G02B 6/4471** (2013.01)

**12 Claims, 14 Drawing Sheets**



(56)

References Cited

U.S. PATENT DOCUMENTS

4,948,220 A	8/1990	Violo et al.	7,171,102 B2	1/2007	Reagan et al.
5,100,221 A	3/1992	Carney et al.	7,173,183 B2	2/2007	McMahon et al.
5,187,766 A	2/1993	Finzel et al.	7,194,181 B2	3/2007	Holmberg et al.
5,249,252 A	9/1993	Noto	7,200,317 B2	4/2007	Reagan et al.
5,260,957 A	11/1993	Hakimi et al. .... 372/39	7,218,827 B2	5/2007	Vongseng et al.
5,274,731 A	12/1993	White	7,218,828 B2	5/2007	Feustel et al.
5,363,440 A	11/1994	Daoud	7,233,731 B2	6/2007	Solheid et al.
5,402,515 A	3/1995	Vidacovich et al.	7,245,809 B1	7/2007	Gniadek et al.
5,421,532 A	6/1995	Richter	7,277,620 B2	10/2007	Vongseng et al.
D362,255 S	9/1995	White	7,295,747 B2	11/2007	Solheid et al.
5,548,678 A *	8/1996	Frost et al. .... 385/135	7,298,952 B2	11/2007	Allen et al.
5,655,044 A	8/1997	Finzel et al.	7,330,546 B2	2/2008	Kessler et al.
5,668,911 A	9/1997	Debortoll	7,330,626 B2	2/2008	Kowalczyk et al.
5,734,776 A	3/1998	Puetz	7,333,707 B2	2/2008	Puetz et al.
5,778,131 A	7/1998	Llewellyn et al.	7,343,071 B2	3/2008	Laurent-Lund
5,790,741 A	8/1998	Vincent et al.	7,349,616 B1 *	3/2008	Castonguay et al. .. G02B 6/445
5,881,200 A	3/1999	Burt ..... 385/142	7,359,610 B2	4/2008	Vongseng
5,946,440 A	8/1999	Puetz	7,366,391 B2	4/2008	Ellison et al.
6,061,492 A	5/2000	Strause et al.	7,369,741 B2	5/2008	Reagan et al.
6,157,714 A	12/2000	Daoud	7,391,954 B1 *	6/2008	Castonguay ..... G02B 6/125
6,160,946 A	12/2000	Thompson et al.	7,400,816 B2	7/2008	Reagan et al.
6,256,444 B1	7/2001	Bechamps et al.	7,406,242 B1	7/2008	Braga
6,259,851 B1	7/2001	Daoud ..... 385/135	7,409,138 B1 *	8/2008	Frazier ..... G02B 6/445
6,263,141 B1	7/2001	Smith	7,418,181 B2	8/2008	Zimmel et al.
6,282,360 B1	8/2001	Milanowski et al.	7,421,183 B2	9/2008	Vongseng
6,356,697 B1	3/2002	Braga et al.	7,433,566 B2	10/2008	Bookbinder et al.
6,363,200 B1	3/2002	Thompson et al.	7,444,050 B2	10/2008	Miyadera et al.
6,385,381 B1	5/2002	Janus et al.	7,450,806 B2 *	11/2008	Bookbinder ..... C03B 37/01446
6,424,781 B1	7/2002	Puetz et al.	7,450,807 B2	11/2008	Bookbinder et al.
6,532,332 B2	3/2003	Solheid et al.	7,496,268 B2 *	2/2009	Escoto ..... G02B 6/4441
6,535,579 B1	3/2003	Blake et al.	7,499,622 B2 *	3/2009	Castonguay ..... G02B 6/3897
6,535,682 B1	3/2003	Puetz et al.	7,505,660 B2	3/2009	Bickham et al.
6,542,652 B1	4/2003	Mahony	7,548,680 B2	6/2009	Castonguay et al.
6,556,763 B1	4/2003	Puetz et al.	7,620,282 B2	11/2009	Bickham et al.
6,577,801 B2	6/2003	Broderick et al. .... 385/125	7,680,380 B2	3/2010	Johnson
6,584,267 B1	6/2003	Caveney et al.	8,380,036 B2	2/2013	Smith
6,614,978 B1	9/2003	Caveney	RE46,525 E	8/2017	Castonguay et al.
6,631,237 B2	10/2003	Knudsen et al.	RE46,701 E *	2/2018	Castonguay ..... 385/135
6,633,717 B1	10/2003	Knight et al.	2002/0181925 A1	12/2002	Hodge et al.
6,661,961 B1	12/2003	Allen et al.	2003/0072518 A1	4/2003	Henschel et al.
6,695,486 B1	2/2004	Falkenberg	2003/0113086 A1	6/2003	Jun et al.
6,710,366 B1	3/2004	Lee et al. .... 257/14	2004/0001686 A1	1/2004	Smith et al. .... 385/135
6,711,339 B2	3/2004	Puetz et al.	2004/0067024 A1	4/2004	Yamada et al.
6,760,531 B1	7/2004	Solheid et al.	2004/0228598 A1	11/2004	Allen et al.
6,766,094 B2 *	7/2004	Smith et al. .... 385/135	2004/0258355 A1	12/2004	Wang et al.
6,788,786 B1	9/2004	Kessler et al.	2005/0021391 A1 *	1/2005	Lu et al. .... 705/11
6,792,191 B1 *	9/2004	Clapp et al. .... 385/135	2005/0021392 A1	1/2005	English et al. .... 705/12
6,795,552 B1	9/2004	Stanush et al.	2005/0129379 A1	6/2005	Reagan et al.
6,796,437 B2	9/2004	Krampotich et al.	2005/0213921 A1 *	9/2005	Mertesdorf et al. .... 385/135
6,802,724 B1	10/2004	Mahony ..... 439/135	2005/0249505 A1	11/2005	Manderscheid et al.
6,810,194 B2	10/2004	Griffiths et al.	2005/0254757 A1	11/2005	Ferretti, III et al.
6,815,612 B2	11/2004	Bloodworth et al.	2005/0265664 A1	12/2005	Yang et al.
6,850,685 B2	2/2005	Tinucci et al.	2006/0008231 A1	1/2006	Reagan et al.
6,922,509 B2	7/2005	Hamada	2006/0083461 A1 *	4/2006	Takahashi et al. .... 385/28
6,925,241 B2	8/2005	Bohle et al.	2006/0133753 A1	6/2006	Nelson et al.
6,959,131 B2	10/2005	Willig	2006/0153516 A1	6/2006	Napiorkowski et al.
6,968,107 B2	11/2005	Belardi et al. .... 385/127	2006/0177190 A1	8/2006	Vongseng et al.
6,983,095 B2	1/2006	Reagan et al.	2006/0193586 A1	8/2006	Hoehne et al.
7,025,523 B2	4/2006	Eberle et al.	2006/0233507 A1	10/2006	Makrides-Saravanos et al.
7,054,513 B2	5/2006	Herz et al. .... 385/12	2006/0263029 A1 *	11/2006	Mudd et al. .... 385/135
7,054,523 B2	5/2006	Takahashi et al.	2006/0275008 A1	12/2006	Xin
7,083,051 B2	8/2006	Smith et al.	2006/0285807 A1	12/2006	Lu et al.
7,086,539 B2	8/2006	Knudsen et al.	2007/0003204 A1	1/2007	Makrides-Saravanos et al.
7,086,898 B2	8/2006	Johnsen et al.	2007/0003205 A1 *	1/2007	Saravanos et al. .... 385/137
7,088,889 B2	8/2006	Takahashi et al.	2007/0036503 A1	2/2007	Solheid et al.
7,088,899 B2	8/2006	Reagan et al.	2007/0165995 A1	7/2007	Reagan et al.
7,090,084 B2	8/2006	Knudsen et al.	2007/0189691 A1	8/2007	Barth et al.
7,102,884 B2	9/2006	Mertesdorf et al.	2007/0192817 A1	8/2007	Landry et al.
7,103,247 B2	9/2006	Yamazaki et al.	2007/0212010 A1	9/2007	Caveney
7,103,255 B2	9/2006	Reagan et al.	2008/0008436 A1	1/2008	Reagan et al.
7,139,461 B2	11/2006	Puetz et al.	2008/0013910 A1	1/2008	Reagan et al.
7,142,764 B2	11/2006	Allen et al.	2008/0019655 A1	1/2008	Vongseng et al.
7,146,089 B2	12/2006	Reagan et al.	2008/0025684 A1	1/2008	Vongseng et al.
7,149,398 B2	12/2006	Solheid et al.			
7,171,100 B2	1/2007	Solheid et al.			

(56)

## References Cited

## U.S. PATENT DOCUMENTS

2008/0031585	A1	2/2008	Solheid et al.	
2008/0042536	A1	2/2008	Guzzo et al.	
2008/0075411	A1	3/2008	Solheid et al.	
2008/0079341	A1	4/2008	Anderson et al.	
2008/0080825	A1	4/2008	Leon et al.	
2008/0080826	A1	4/2008	Leon et al.	
2008/0080827	A1	4/2008	Leon et al.	
2008/0080828	A1	4/2008	Leon et al.	
2008/0080829	A1	4/2008	Smith et al.	
2008/0093101	A1	4/2008	Kessler et al.	
2008/0112675	A1	5/2008	Lewallen et al.	
2008/0116153	A1	5/2008	Smith et al.	
2008/0118207	A1	5/2008	Yamamoto et al.	
2008/0124038	A1	5/2008	Kowalczyk et al.	
2008/0124039	A1	5/2008	Gniadek et al.	
2008/0131057	A1*	6/2008	McGranahan	G02B 6/444 385/75
2008/0145013	A1	6/2008	Escoto et al.	
2008/0152292	A1*	6/2008	Wilken	G02B 6/4452 385/135
2008/0170833	A1	7/2008	Castonguay et al.	
2008/0212928	A1	9/2008	Kowalczyk et al.	
2008/0219633	A1	9/2008	Smith et al.	

## FOREIGN PATENT DOCUMENTS

EP	0744640	A1	11/1996
EP	0744640	B1	8/2006
JP	62-27312		2/1987
JP	H02-007009	A	1/1990
JP	H11-326683	A	11/1999
JP	2001-356217	A	12/2001
JP	2002-221638	A	8/2002
JP	2003-262743	A	9/2003
JP	2003-307630	A	10/2003
JP	2004-109730	A	4/2004
JP	2004-126471	A	4/2004
JP	2004-221420	A	8/2004
JP	2004-317838	A	11/2004
JP	2005-115263	A	4/2005
JP	2005-165303	A	6/2005
JP	2006-201662	A	8/2006
JP	2006-313212	A	11/2006
JP	2006-317630	A	11/2006
WO	WO 89/05989	A1	6/1989
WO	WO 91/18311	A2	11/1991
WO	WO 1995/06347	A1	3/1995
WO	WO 02/33457	A2	4/2002
WO	WO 2004/086112	A1	10/2004
WO	WO 2005/050277	A2	6/2005
WO	WO 2005/088373	A1	9/2005
WO	WO 2006/050505	A1	5/2006
WO	WO 2006/112979	A2	10/2006
WO	WO 2006/127457	A1	11/2006
WO	WO 2006/135524	A2	12/2006
WO	WO 2008/088675	A2	7/2008
WO	WO 2008/112179	A1	9/2008

## OTHER PUBLICATIONS

Gibson et al., Evanescent Field Analysis of Air-Silica Microstructure Waveguides, IEEE, 0-7803-7105-Apr. 2001, 2001, pp. 709-710.

Monro et al., "Holey Fibers with random cladding distributions" Optic Letters, vol. 25, No. 4; Feb. 15, 2000.

Emerson product sheet, "NetSpan™ Fiber Distribution Hub Fiber Cross-Connect Enclosure", "Outside Plant for Business-Critical Continuity", © 2006 Emerson Network Power Energy Systems, North America, www.EmersonNetworkPower.com/Energy\_Systems.Com, 2 pages.

Hitachi Cable Review No. 24 "Low-loss Holey Fiber", Aug. 2005, 5 pages.

Draka Comteq/Optical Fibre, Issue Date: Aug. 2006, Supersedes: -/-, "BendBright<sup>SM</sup> Single Mode Optical Fibre, Enhances low macrobending sensitive, low water peak fibre, Product Type: G.652D, Coating Type: ColorLock™ and Natural", www.drakafibre.com www.draka.com, 2 pages.

Corning Cable Systems, "OptiTect® Gen III Splitter Modules," Standard Recommended Procedure (SRP) 000-258, Issue 1, 6 pages (Nov. 2007).

Corning Cable Systems, "OptiTect® Gen III Splitter Modules," Standard Recommended Procedure (SRP) 000-245, Issue 7, 4 pages (Mar. 2009).

Corning Cable Systems, "Outdoor Multidwelling Unit (MDU) with Splitter Modules," Standard Recommended Procedure (SRP) 003-764, Issue 1, 16 pages (Nov. 2007).

Corning Cable Systems, "OptiTect® FDH-HDF Cabinet," Standard Recommended Procedure (SRP) 003-668, Issue 1f, 20 pages (Mar. 2004).

Corning Cable Systems, "OptiTect® Premiere Cabinet FDH-HDF," Standard Recommended Procedure (SRP) 003-668, Issue 5, 26 pages (Mar. 2005).

ADC, "OmniReach™ FTTX Solutions. Passive Optical Splitter Modules. 6th Edition," 102902AE, Dec. 2008 Revision, Copyright 2008, 2007, 2006, 19 pages.

International Search Report and Written Opinion for PCT/US2008/000095 dated Sep. 12, 2008.

Office Action for Australian Patent Application No. 2008226892 dated May 19, 2011.

Office Action for Australian Patent Application No. 2008226892 dated Sep. 7, 2011.

Office Action for Canadian Patent Application No. 2,679,996 dated Nov. 30, 2011.

Office Action for Canadian Patent Application No. 2,754,111 dated Nov. 29, 2011.

Office Action for Canadian Patent Application No. 2,754,149 dated Nov. 29, 2011.

Office Action for parent Reissue U.S. Appl. No. 13/162,115 dated Dec. 19, 2011.

Office Action for parent Reissue U.S. Appl. No. 13/162,115 dated May 4, 2012.

Office Action for parent Reissue U.S. Appl. No. 13/162,115 dated Dec. 4, 2013.

Office Action for parent Reissue U.S. Appl. No. 13/162,115 dated Mar. 9, 2015.

Office Action for parent Reissue U.S. Appl. No. 13/162,115 dated Feb. 11, 2016.

Office Action for parent Reissue U.S. Appl. No. 13/162,115 dated Nov. 9, 2016.

Office Action for parent Reissue U.S. Appl. No. 13/162,115 dated Feb. 23, 2017.

Office Action for parent Reissue U.S. Appl. No. 13/162,115 dated Jul. 10, 2017.

Notice of Allowance and Notice of Allowability for parent Reissue U.S. Appl. No. 13/162,115 dated Nov. 14, 2017.

Office Action for Continuation Reissue U.S. Appl. No. 14/028,338 dated Feb. 11, 2016.

Office Action for Continuation Reissue U.S. Appl. No. 14/028,338 dated Dec. 9, 2014.

Notice of Allowance and Notice of Allowability for Continuation Reissue U.S. Appl. No. 14/028,338 dated Jul. 13, 2017.

"Channel Insertion Loss for 1×64 and 1×128 Split EPONS," IEEE802.3 Plenary Meeting, Dallas, Texas, Siemens Networks SA (Nov. 14-16, 2006).

Corning Cable Systems Standard Recommended Procedure (SRP) 003-718, Issue 2, 24 pages (May 2006).

Corning Cable Systems Standard Recommended Procedure (SRP) 003-735, Issue 4, 31 pages (Sep. 2012).

European Search Report and Opinion for European Application No. EP14180061.5, 13 pages dated Nov. 21, 2014.

(56)

**References Cited**

## OTHER PUBLICATIONS

Office Action for Canadian Patent Application No. 2,679,996 dated Dec. 9, 2016.

Office Action for Canadian Patent Application No. 2,679,996 dated Jul. 27, 2015.

Office Action for Canadian Patent Application No. 2,679,996 dated Jun. 9, 2014.

Office Action for Canadian Patent Application No. 2,679,996 dated Jun. 7, 2013.

Office Action for Canadian Patent Application No. 2,679,996 dated Dec. 4, 2012.

Office Action for Canadian Patent Application No. 2,679,996 dated Jul. 26, 2012.

Office Action for Canadian Patent Application No. 2,679,996 dated Apr. 24, 2012.

Office Action for Canadian Patent Application No. 2,754,149 dated Dec. 9, 2016.

Office Action for Canadian Patent Application No. 2,754,149 dated Jul. 27, 2015.

Office Action for Canadian Patent Application No. 2,754,149 dated Nov. 15, 2013.

Office Action for Canadian Patent Application No. 2,754,149 dated Jun. 7, 2013.

Office Action for Canadian Patent Application No. 2,754,149 dated Dec. 5, 2012.

Office Action for Canadian Patent Application No. 2,754,149 dated Aug. 7, 2012.

Office Action for Canadian Patent Application No. 2,754,149 dated Apr. 25, 2012.

Corning® SMF-28e® Optical Fiber Product Information, PI1344, 4 pages (Jan. 2005).

International Telecommunication Union, ITU-T G.652, Telecommunication Standardization Sector of ITU, Jun. 2005, Series G: Transmission Systems and Media, Digital Systems and Networks, Transmission media characteristics—Optical fibre cables, Characteristics of a single-mode optical fibre and cable, ITU-T Recommendation G.652, 22 pgs.

International Telecommunication Union, ITU-T G.657, Telecommunication Standardization Sector of ITU, Dec. 2006, Series G: Transmission Systems and Media, Digital Systems and Networks, Transmission media and optical systems characteristics—Optical Fibre Cables, Characteristics of a bending loss insensitive single mode optical fibre and cable for the access network, ITU-T Recommendation G.657, 20 pgs.

Pickrell et al., “Novel Techniques for the Fabrication of Holey Optical Fibers” Spie Conference Proceedings, vol. 4578, pp. 271-282; 2001.

PennWell Corporation, “Bringing Fiber to the multi-dwelling unit”, reprinted with revisions to format, from the Oct. 2005 edition of Cabling Installation & Maintenance, Copyright 2005.

Corning Cable Systems LLC, Product Information Sheet, OptiTec™ Premier Local Convergence Cabinet, An Evolant © Solutions Product, Sep. 2006, 6 pages.

Fons, Fiber Optic Network Solutions, “Fiber Distribution Terminals”, Fiber Access Terminals, Copyright © FONS Corp. 2005, www.fons.com, 3 pages.

Fons, Fiber Optic Network Solutions, “Indoor Fiber Distribution Terminal”, “Interior Wall Mount Terminals”, Copyright © FONS Corp. 2005, www.fons.com, 3 pages.

ADC Spec Sheet “OmniReach™ FTTX Solutions”, “Outdoor Fiber Distribution Terminal 24 (OFDT-24)”, 103335AE, Jan. 2007 Revision © 2006, 2007 www.adc.com, 4 pages.

ADC Spec Sheet “OmniReach™ FTTX Solutions”, “Indoor Fiber Distribution Terminal”, 103266AE, Aug. 2006 Revision © 2006 www.adc.com, 4 pages.

ADC Catalog “OmniReach™ FTTP Solutions”, “Fiber Distribution Terminals”, “FTTP Infrastructure Solutions”, “Fiberglass In-Ground Mounting Sleeve”, “Above Ground Cabinet Mounting”, “Pad or Pole Mounting”, “Accessories”, 1276550 Apr. 2004, Revision © 2003, 2004 www.adc.com, 12 pages.

SPC TelEquip product sheet, “FiberGard Distribution Terminal 48 Fiber-Indoor/Outdoor”, “The compact solution for fiber provisioning”, www.spc.net/2005/Fiber%/20Optics%20FiberGard%20-Dist%20Term%2048.html.

Corning Cable Systems, SRP-009-005, “Installation Instructions for the IBM Fiber Transport System-III (FTS-III),” Issue 1, Jun. 1994, 15 pages.

\* cited by examiner

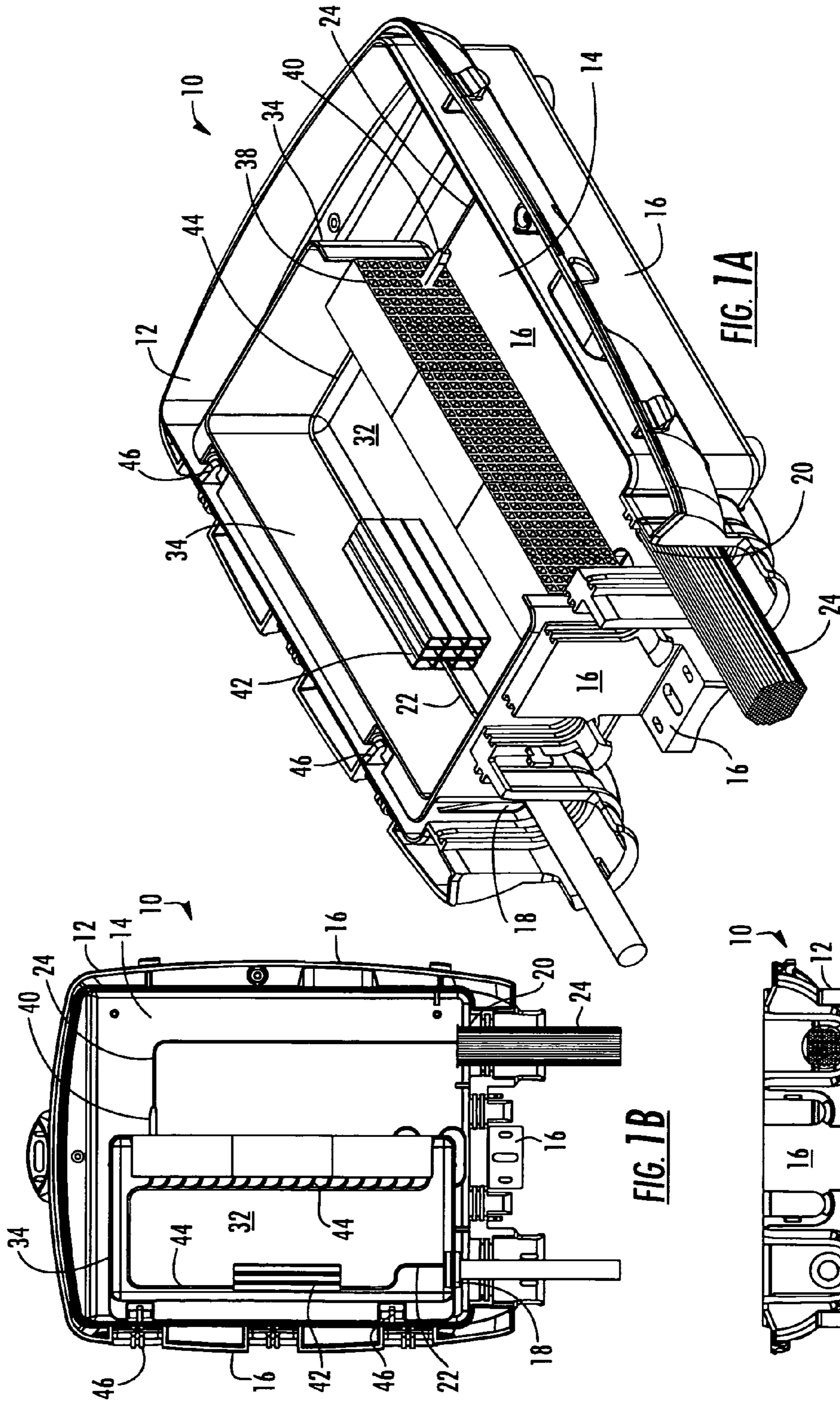


FIG. 1A

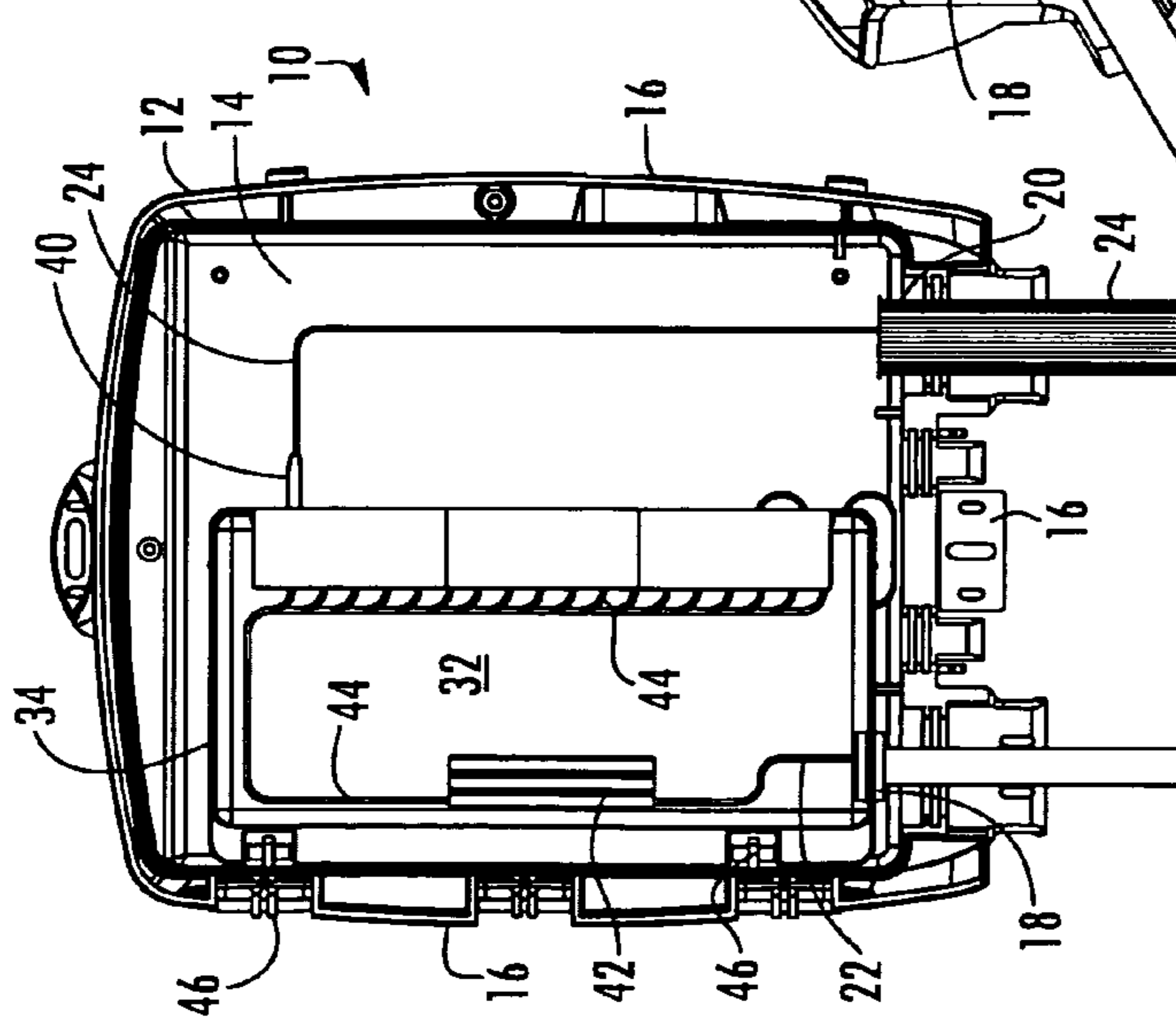


FIG. 1B

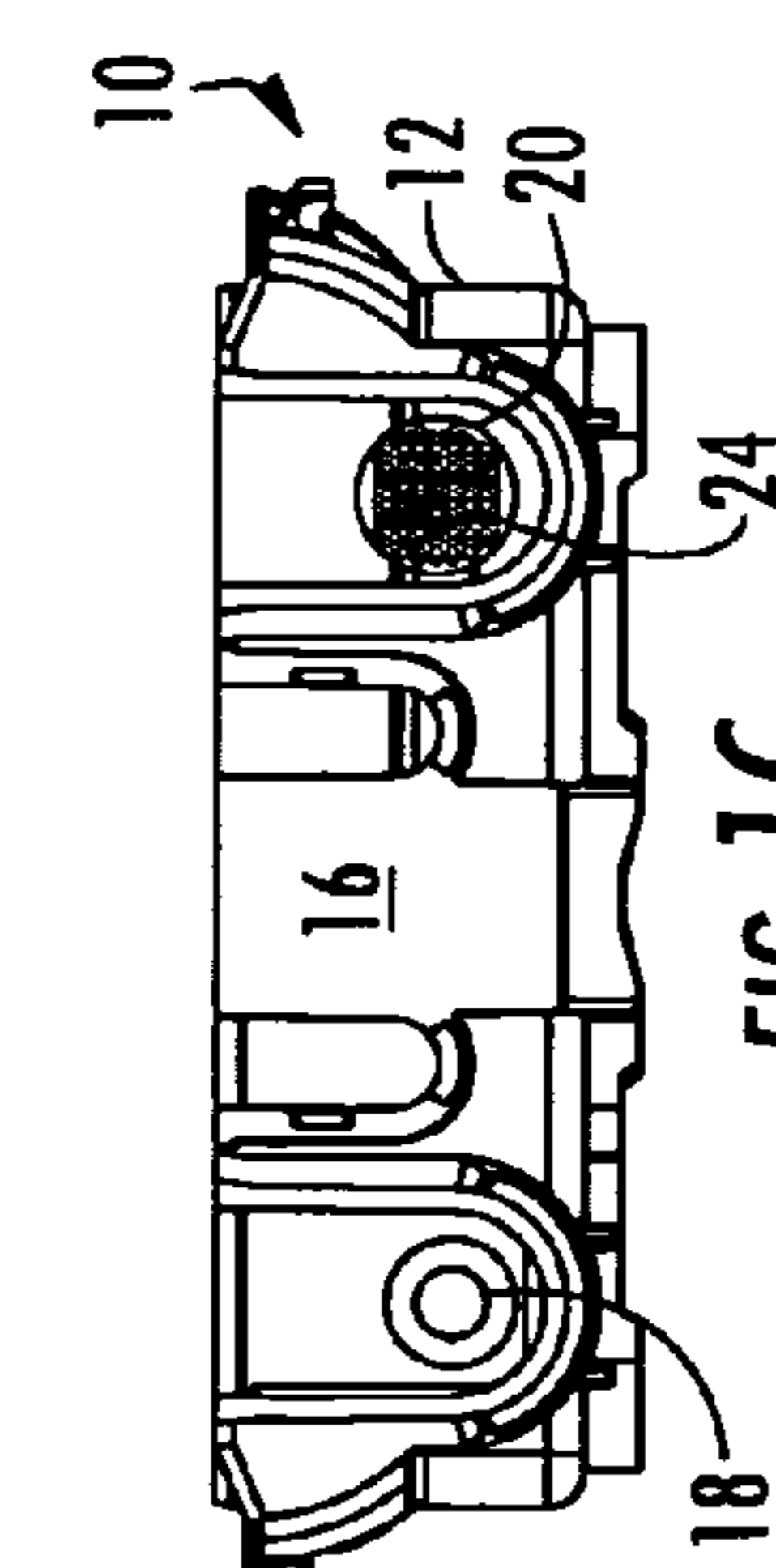
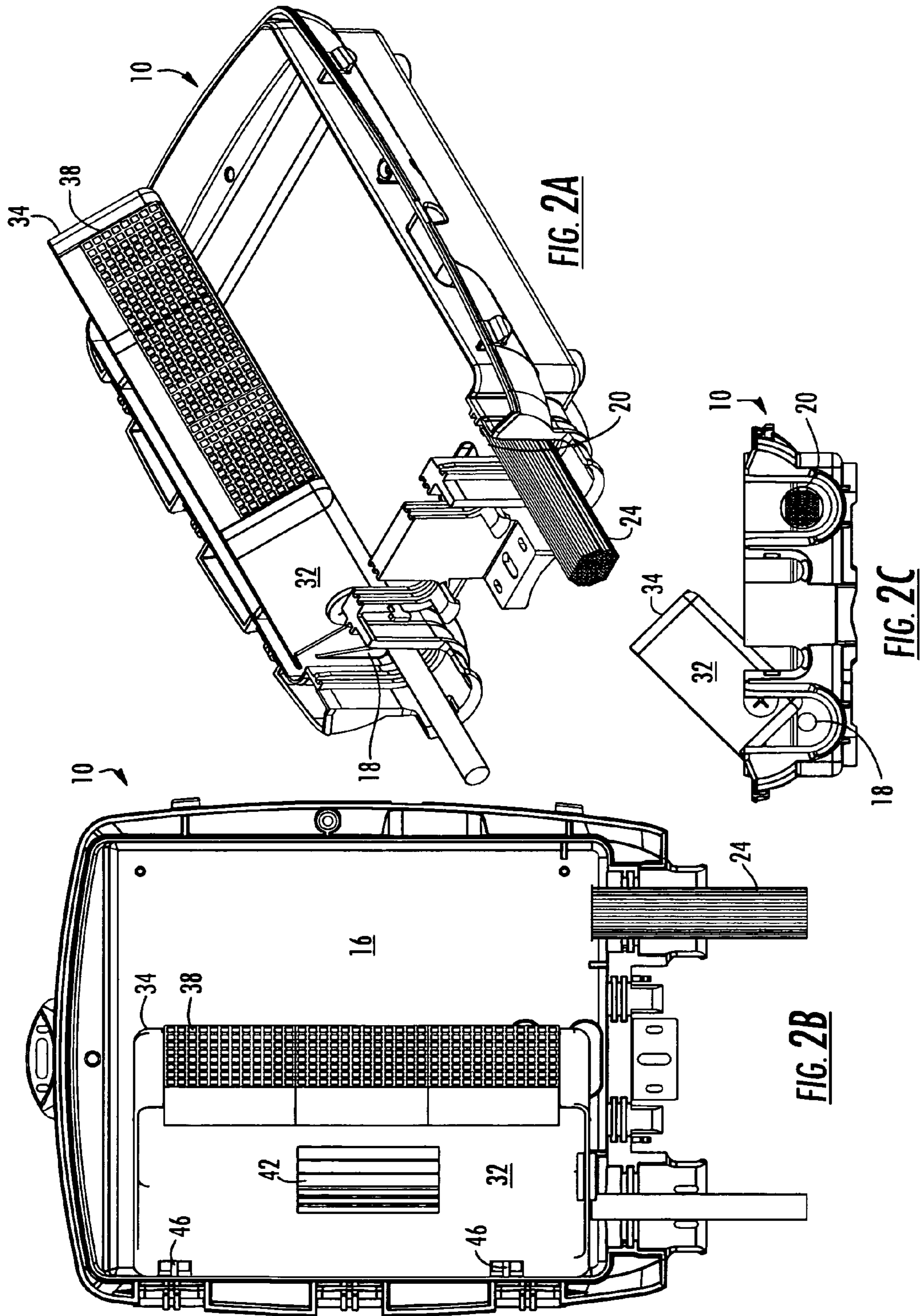
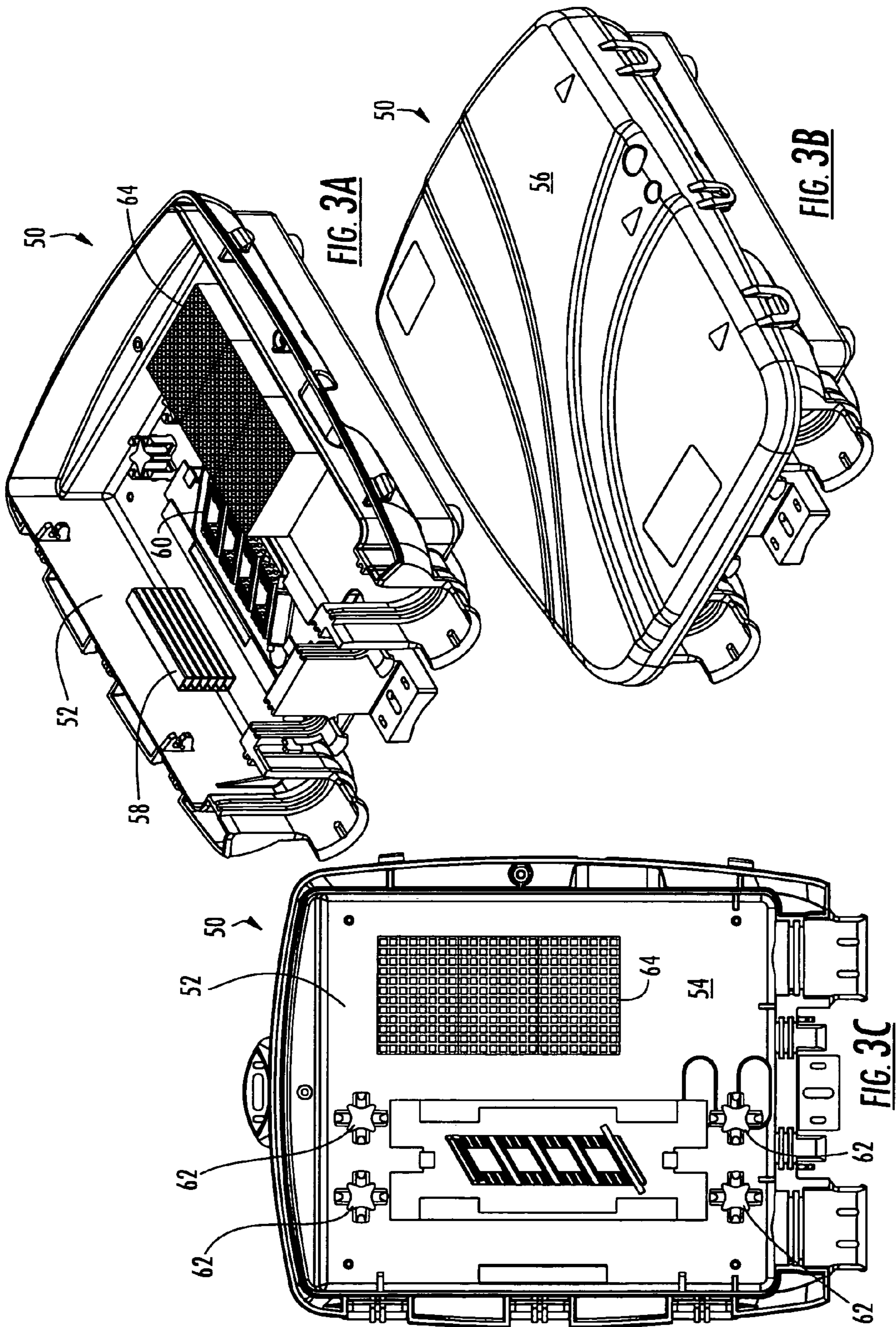
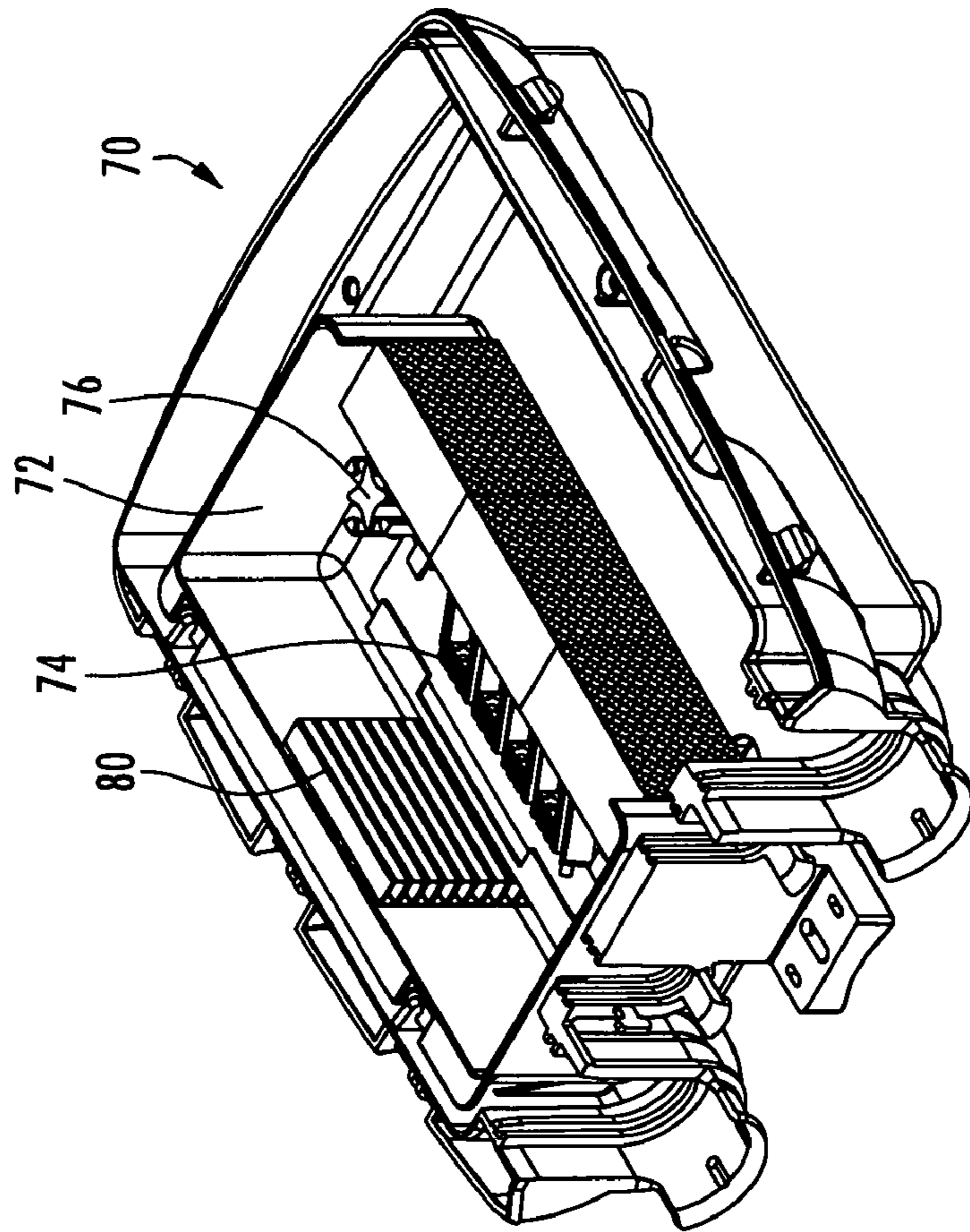


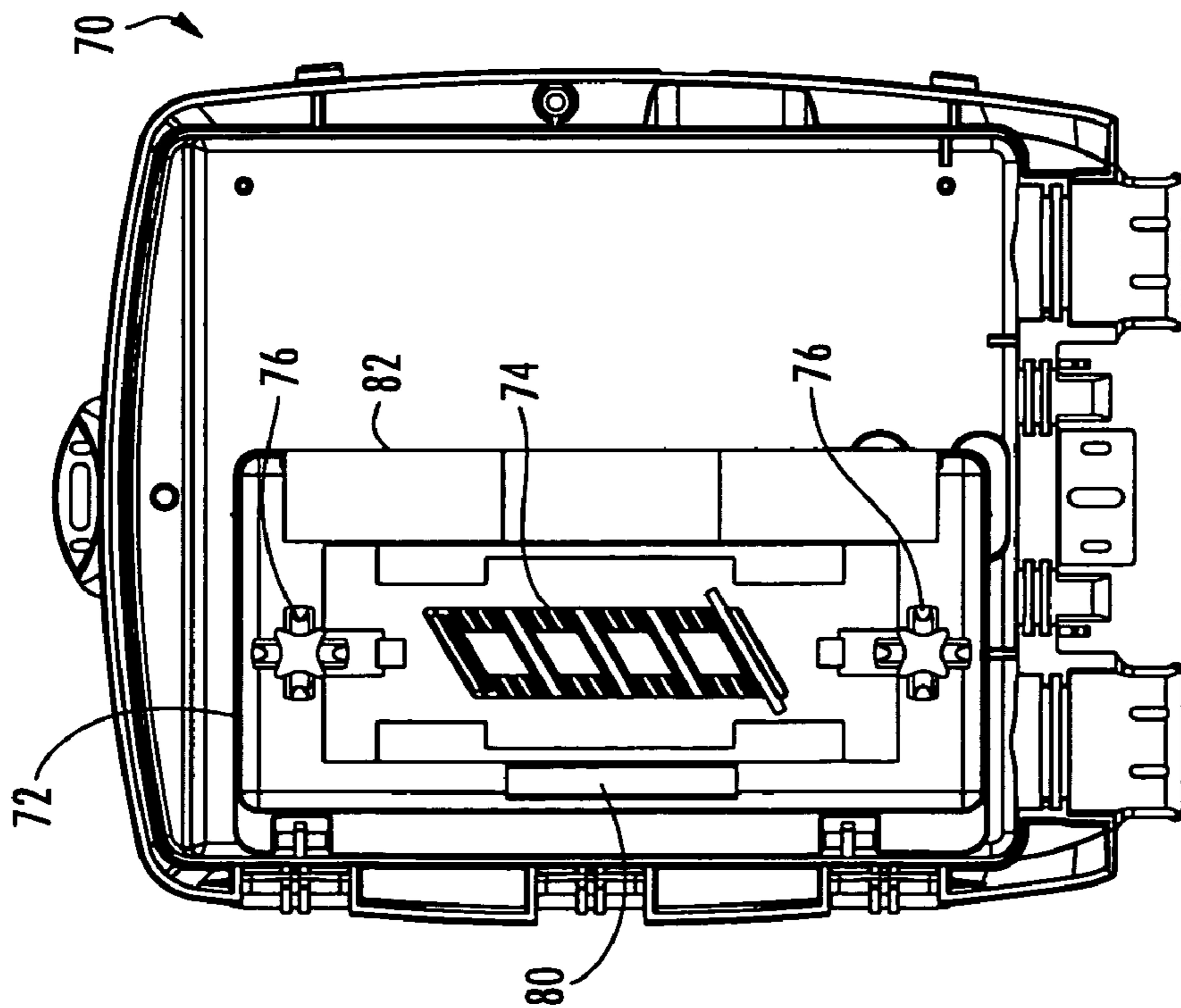
FIG. 1C





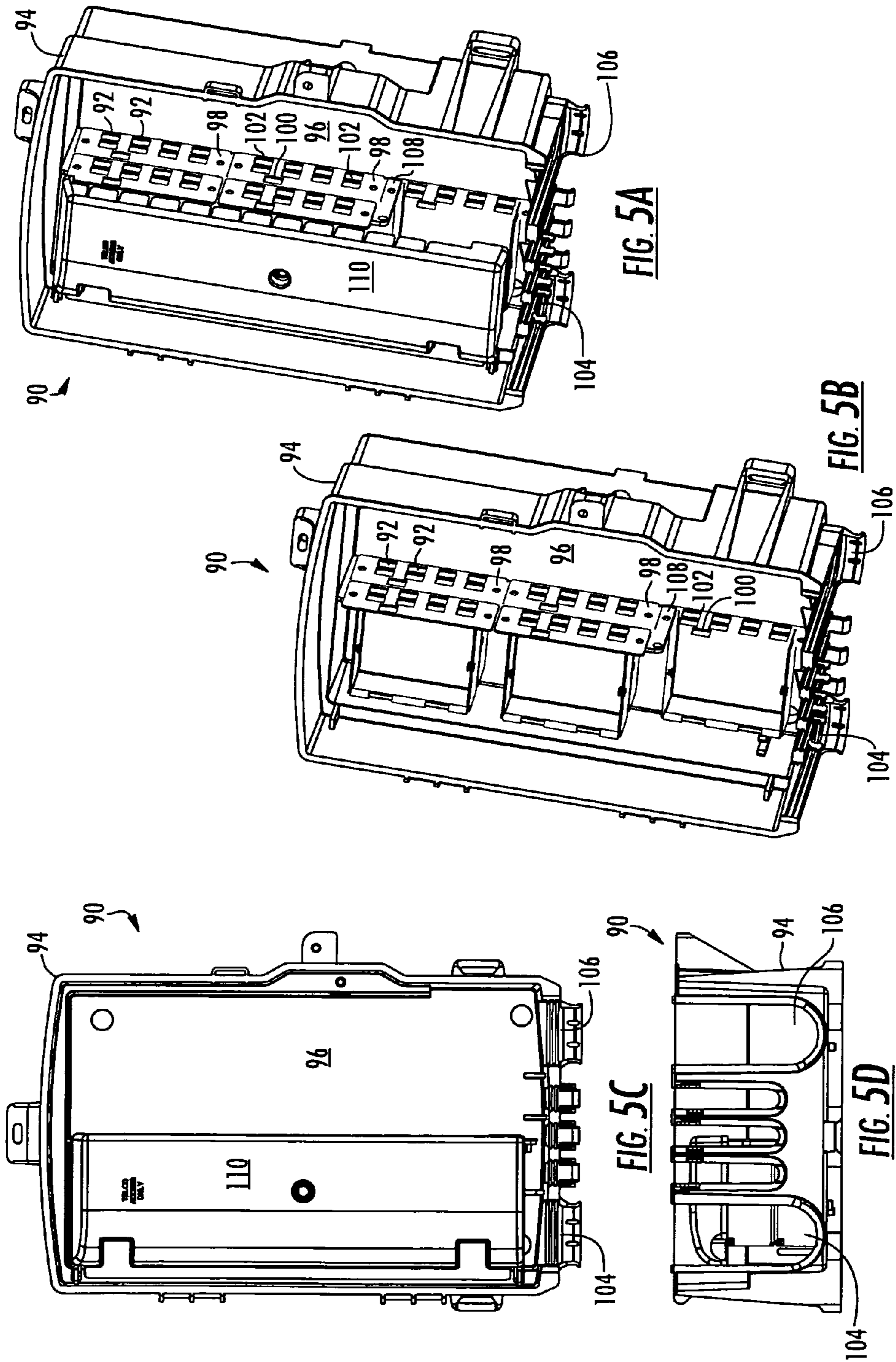


**FIG. 4A**



**FIG. 4B**





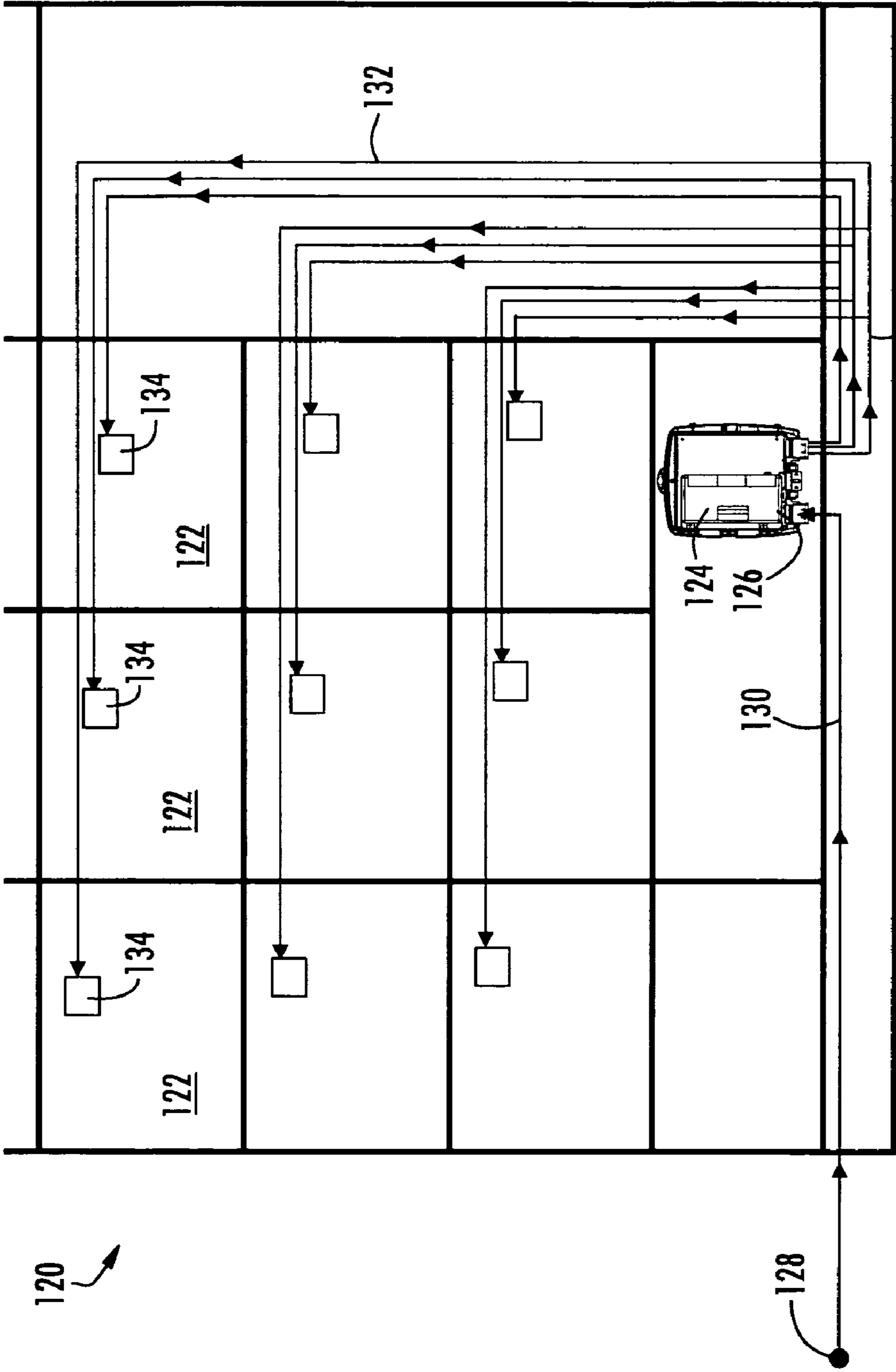
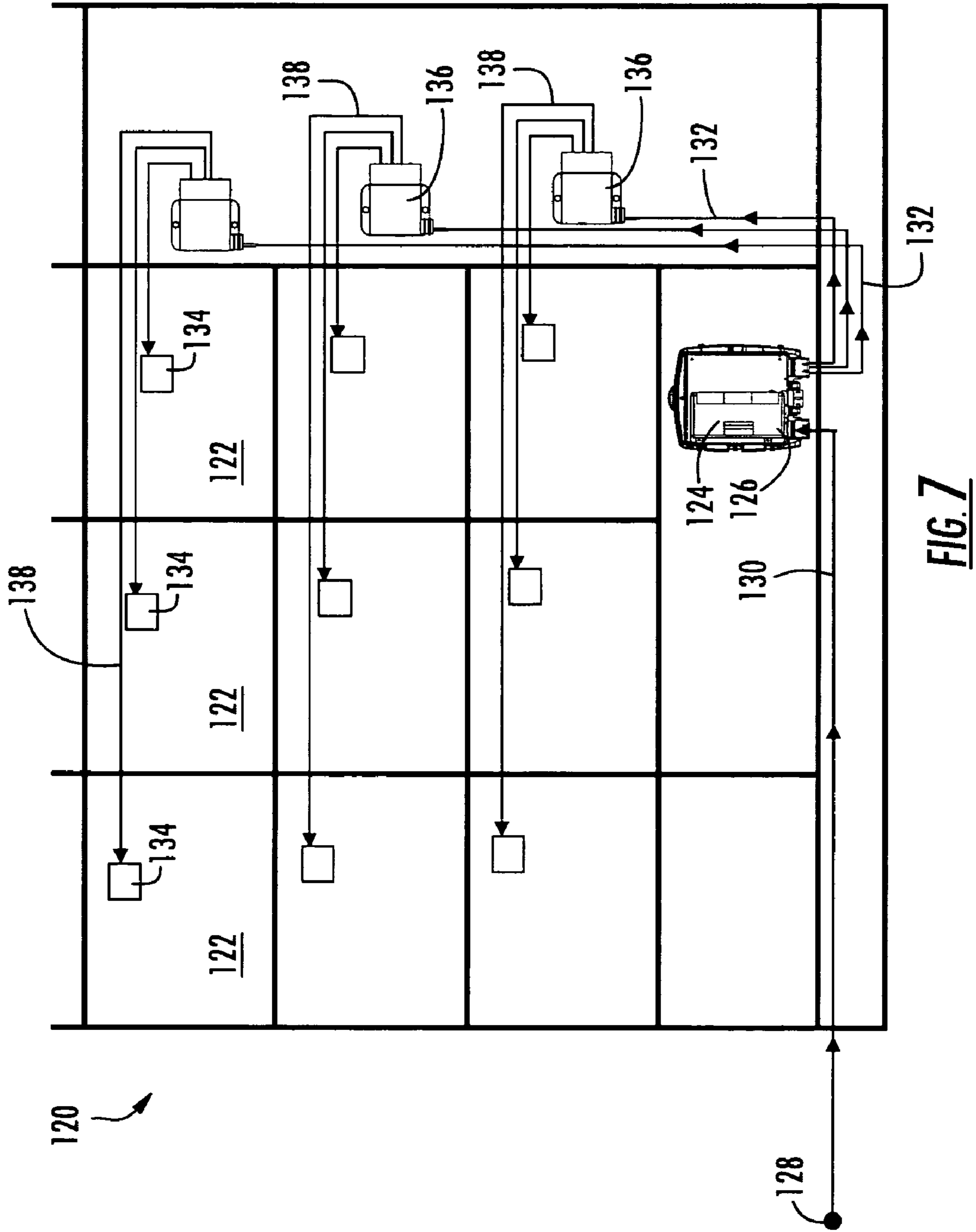
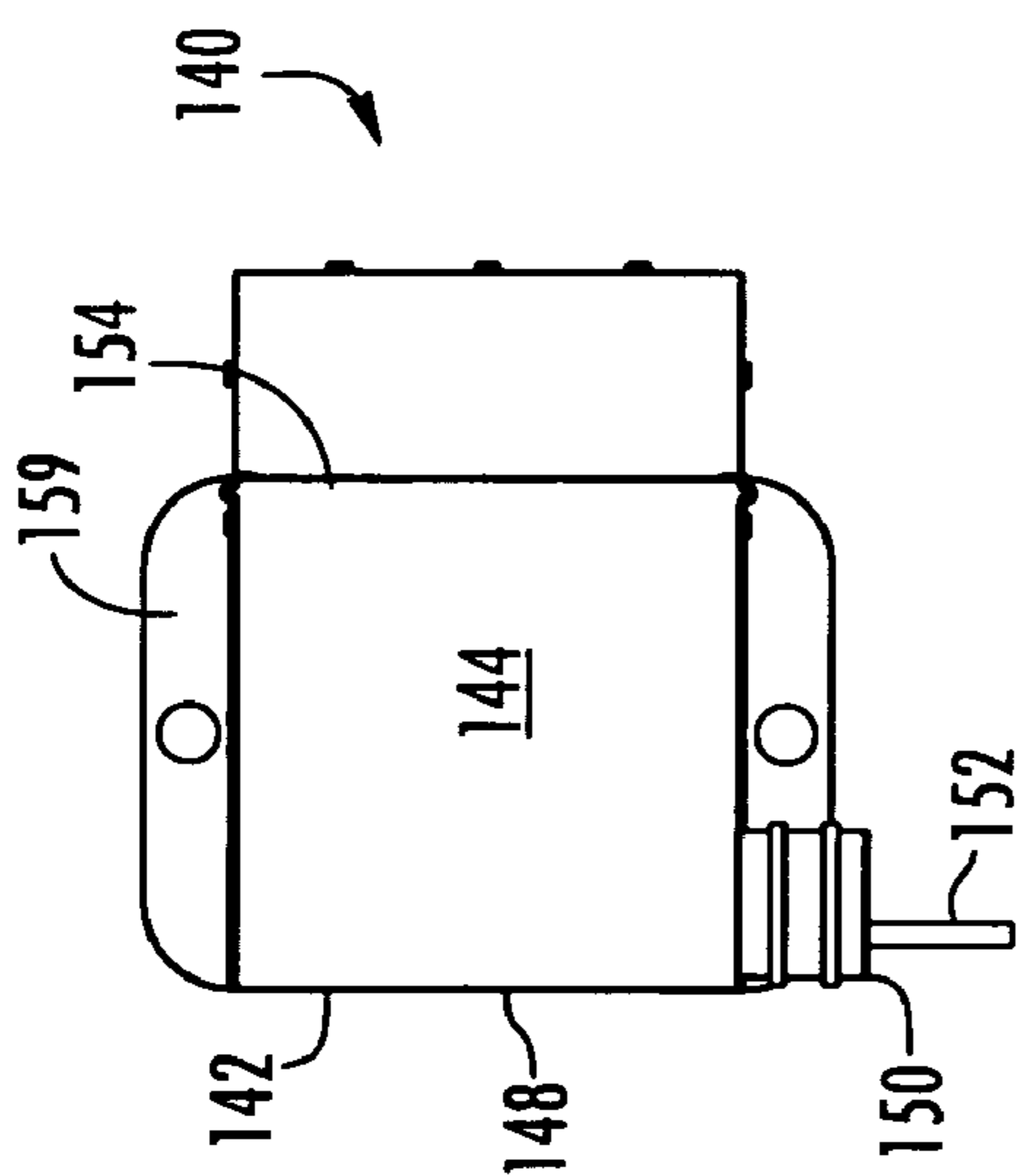
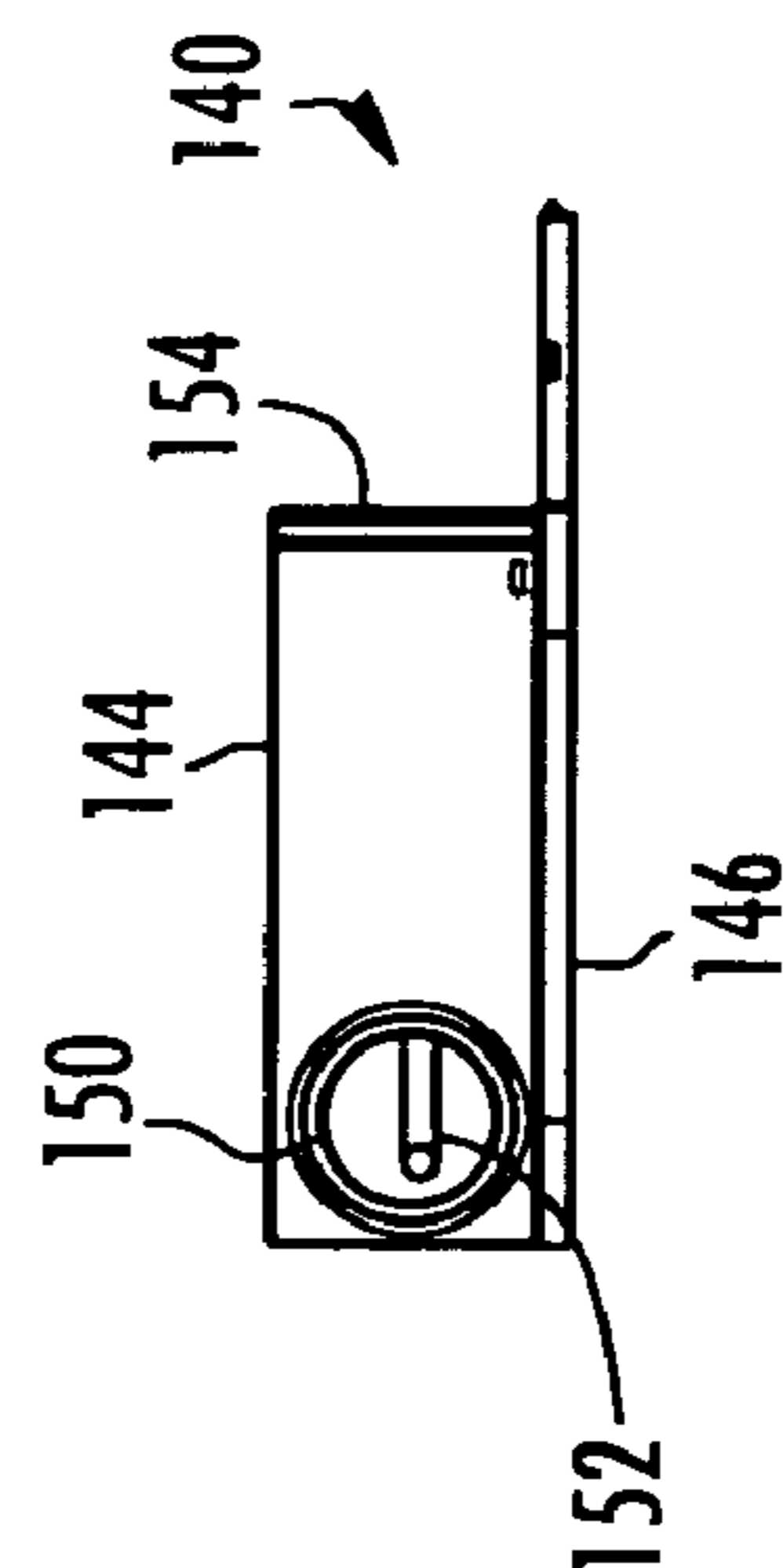


FIG. 6

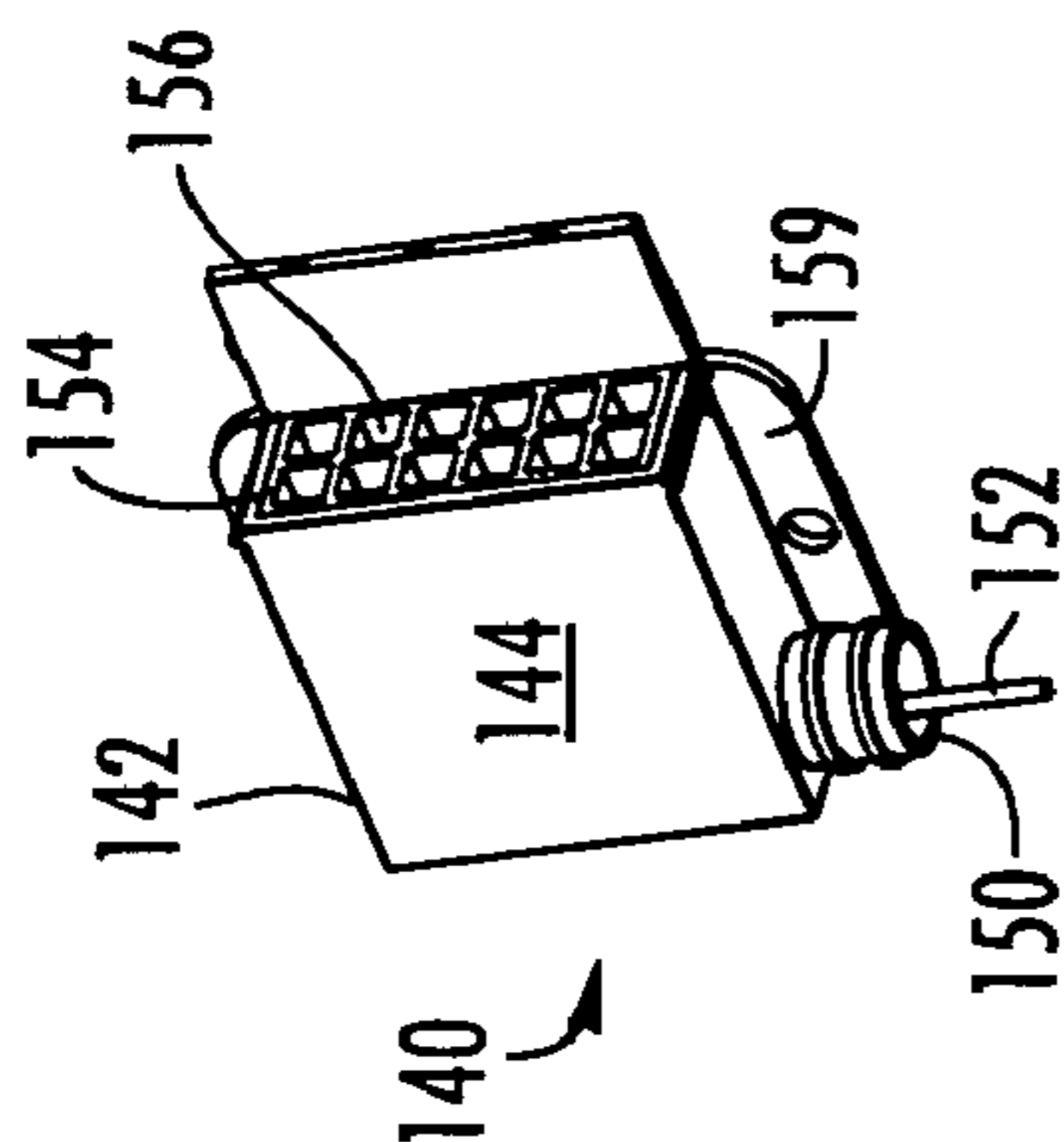




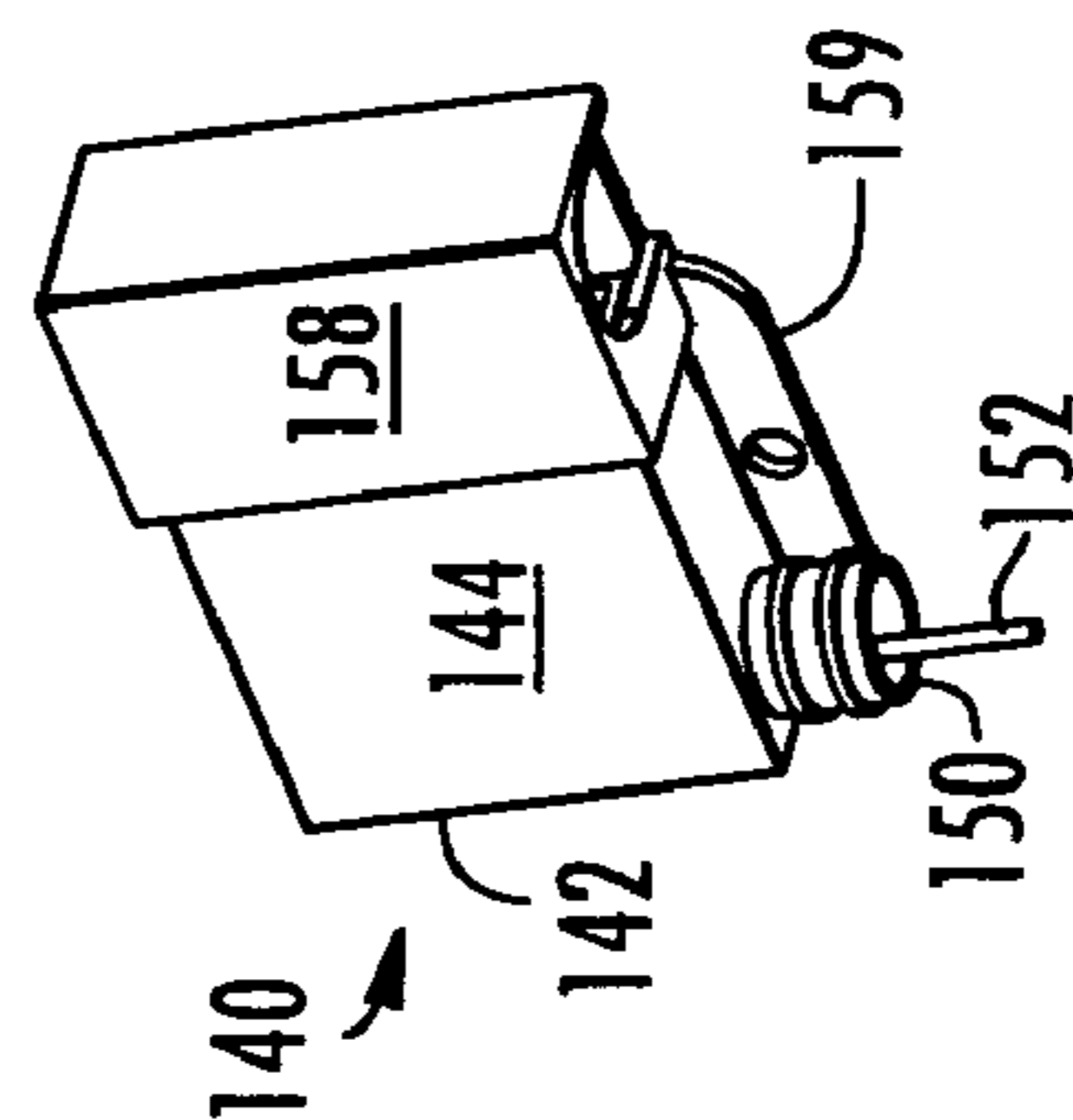
**FIG. 8C**



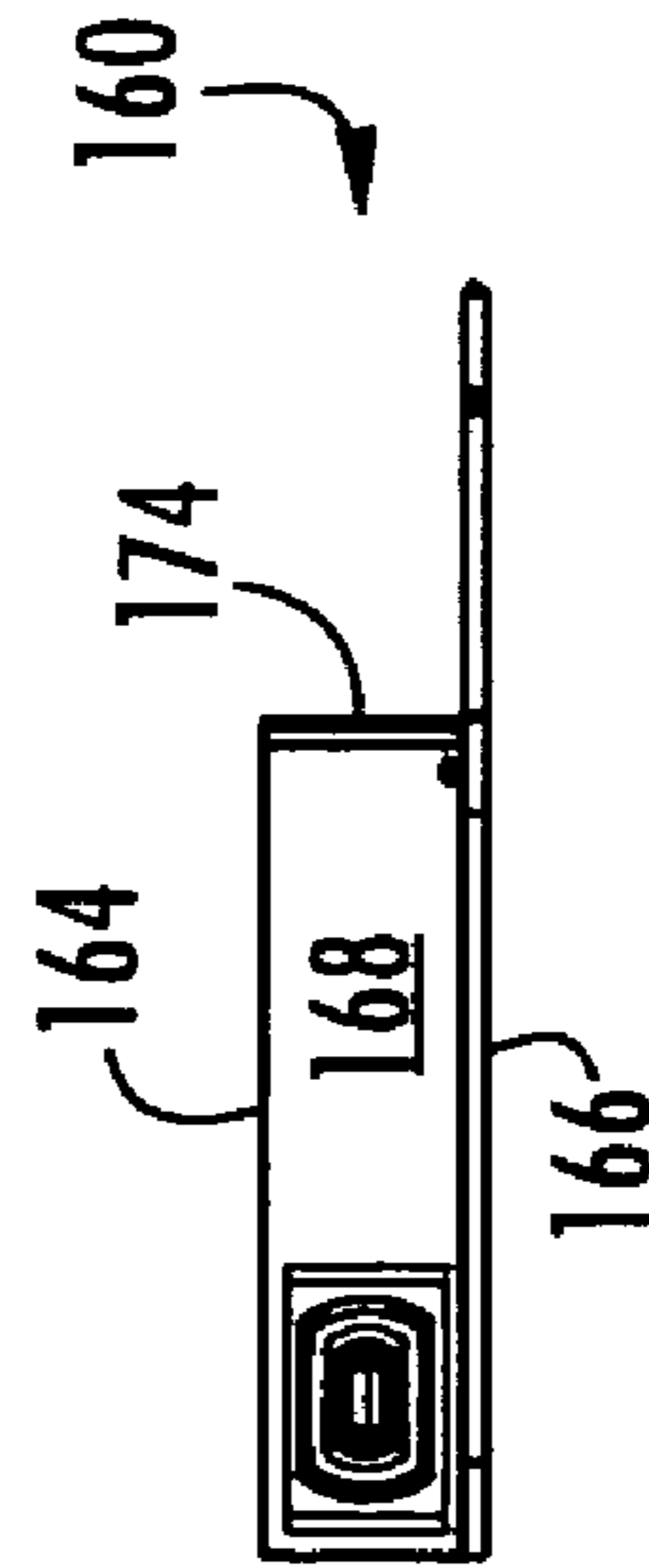
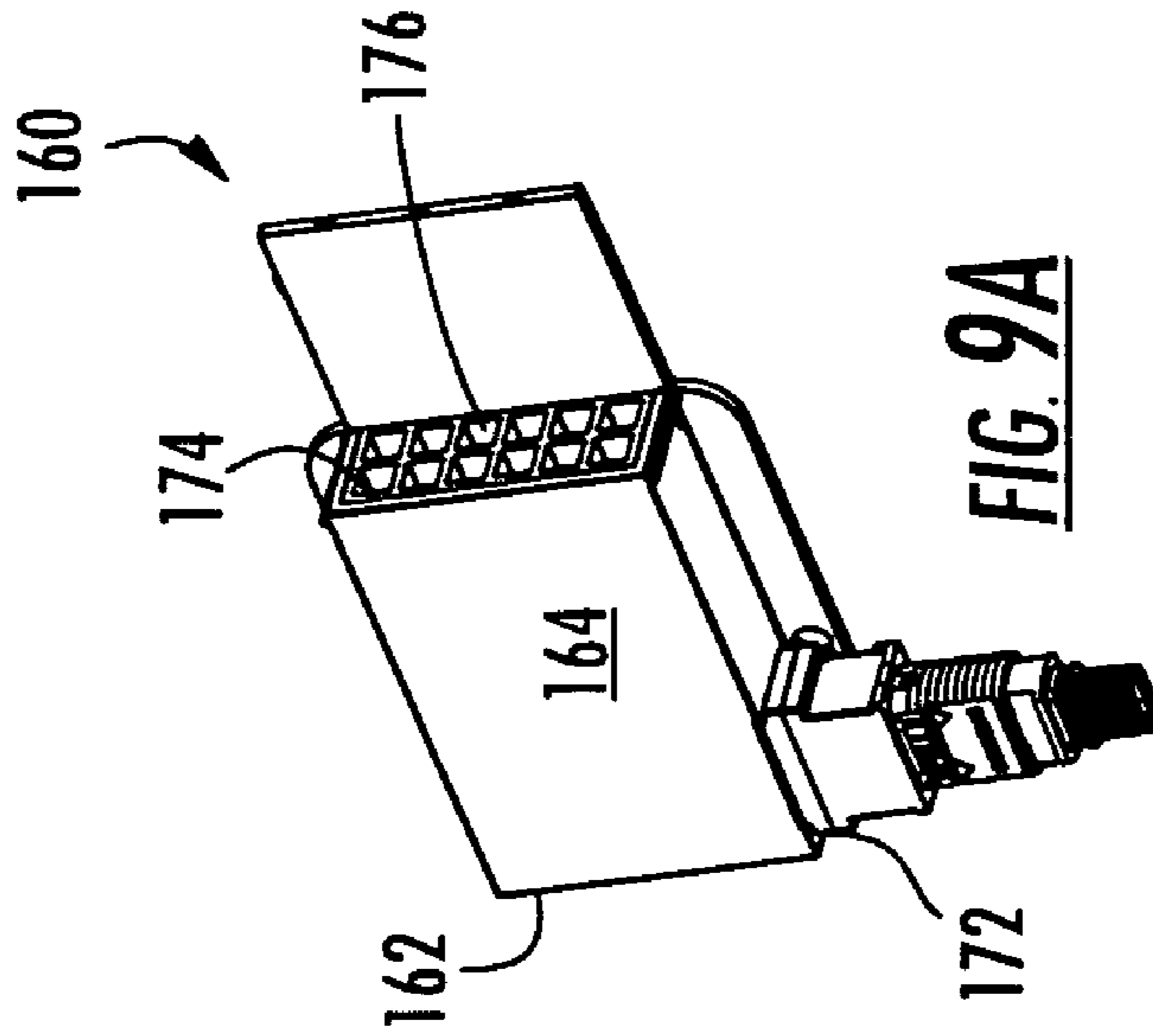
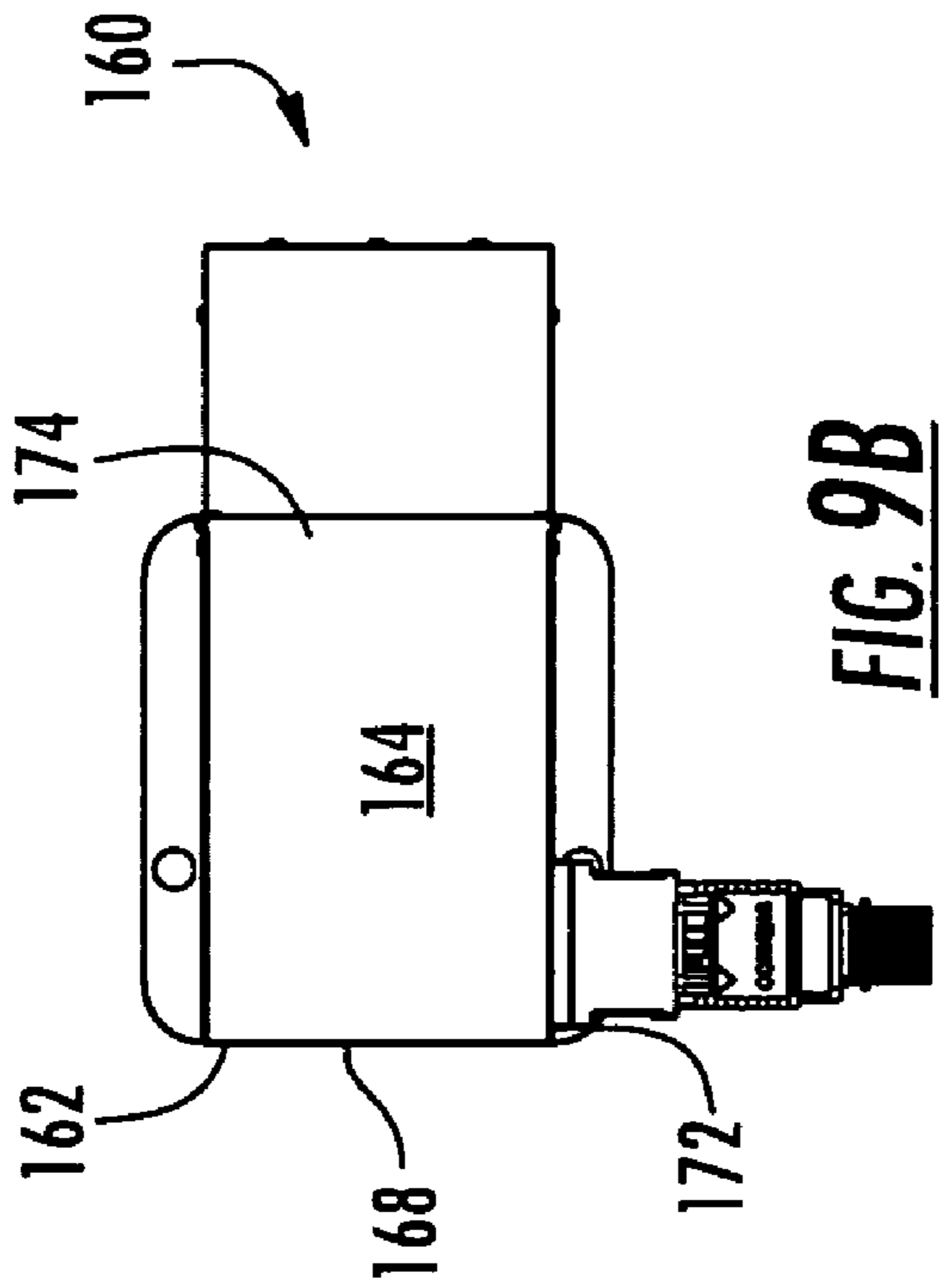
**FIG. 8D**



**FIG. 8A**



**FIG. 8B**



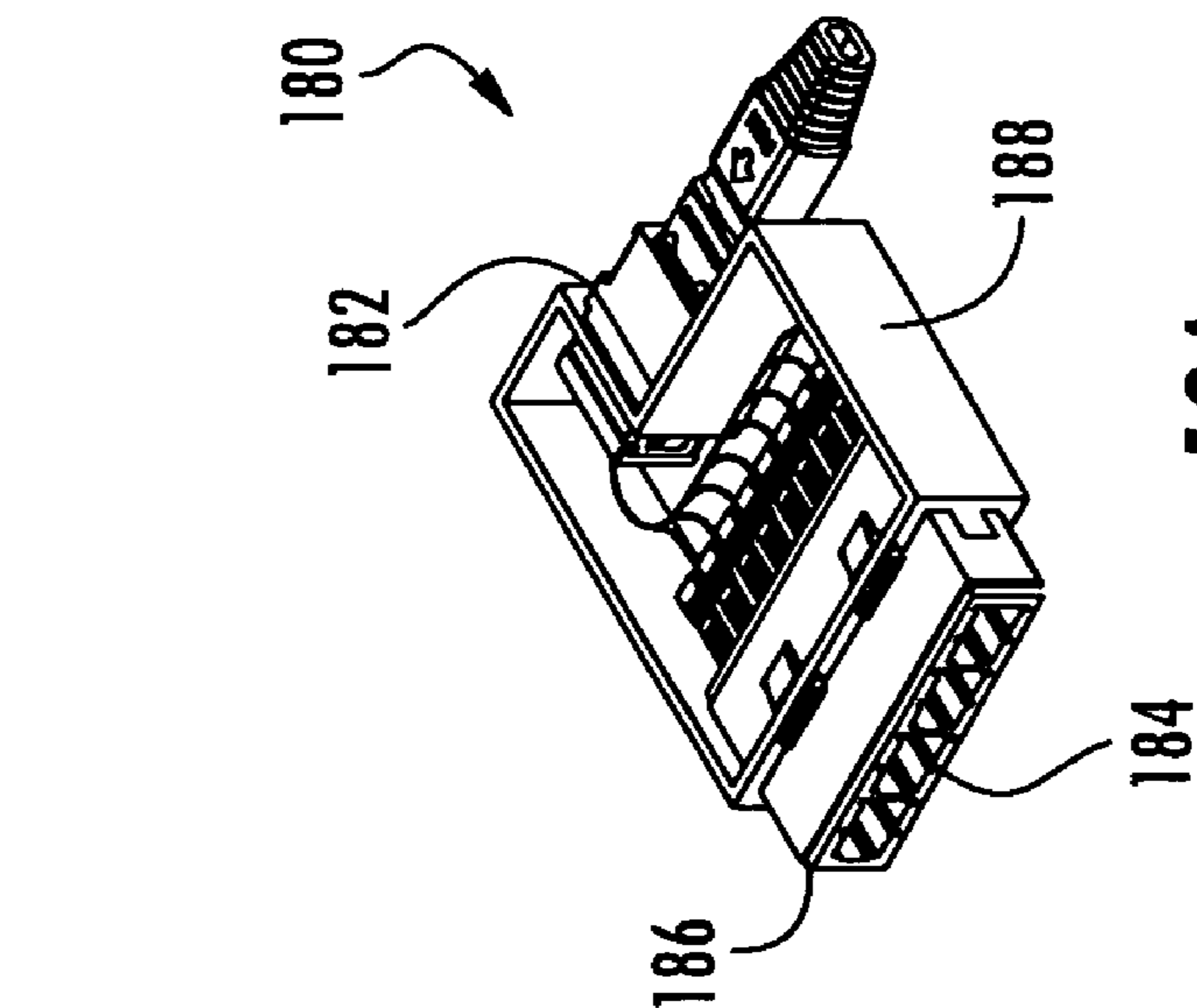


FIG. 10A

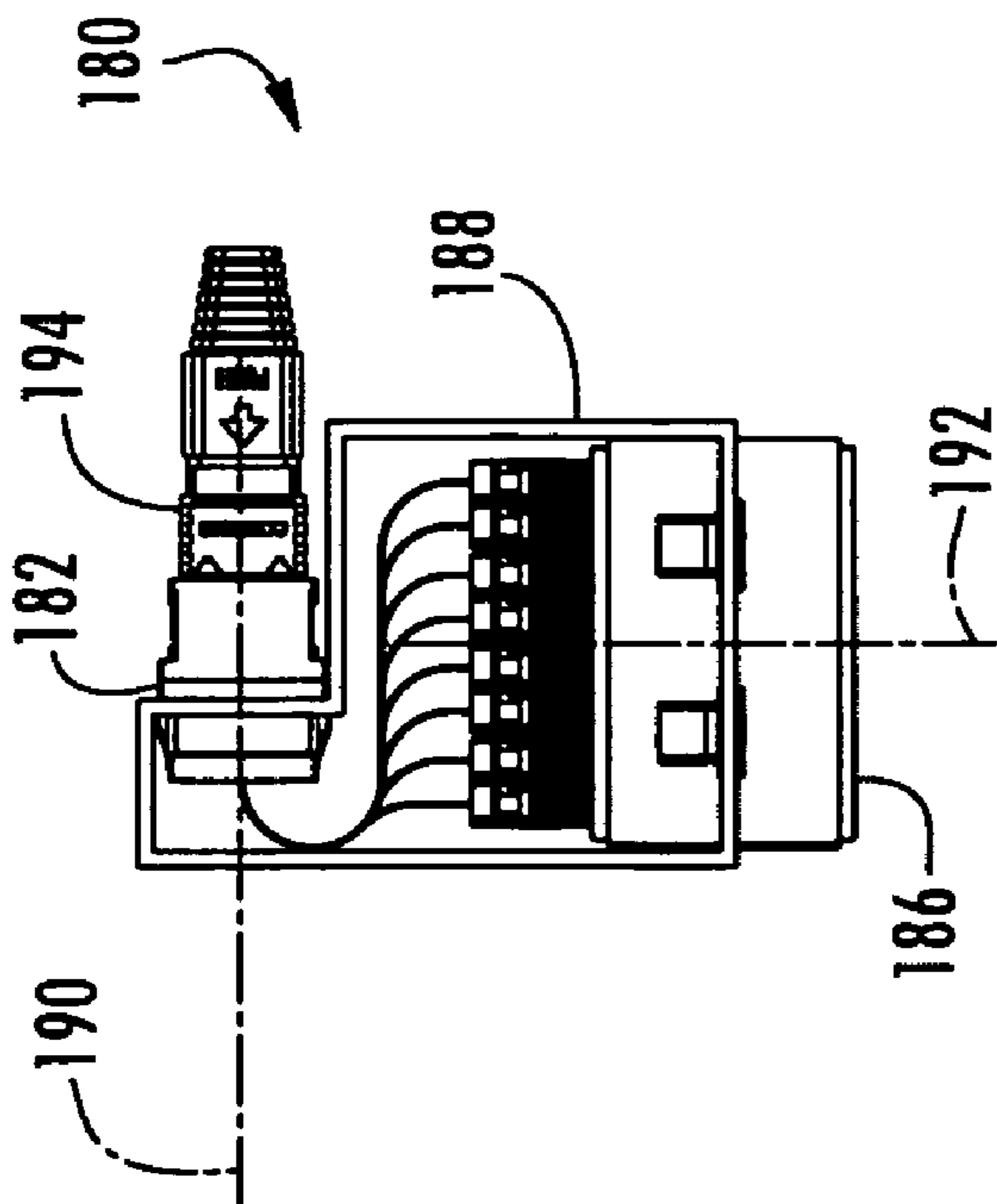


FIG. 10B

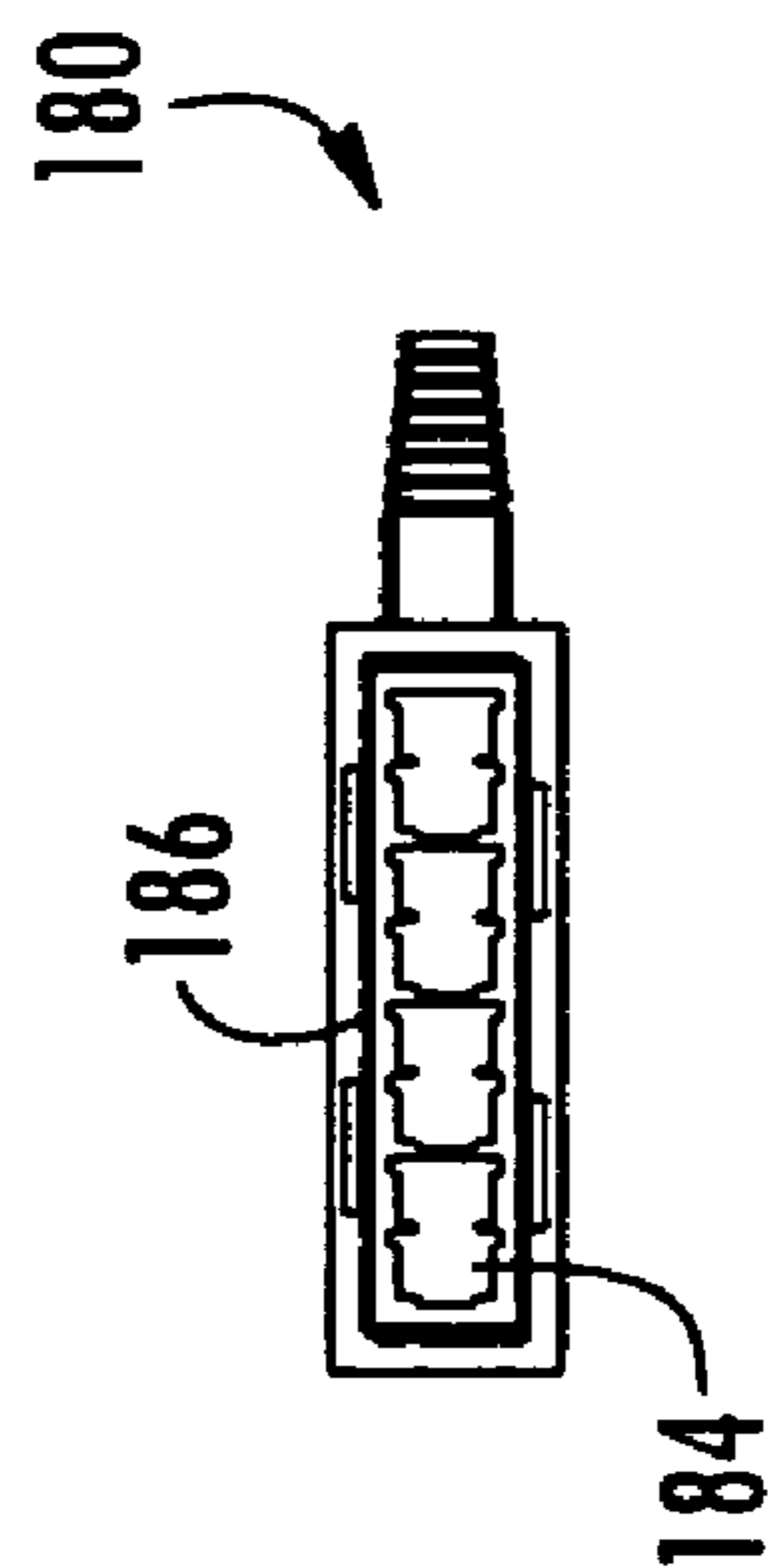


FIG. 10C

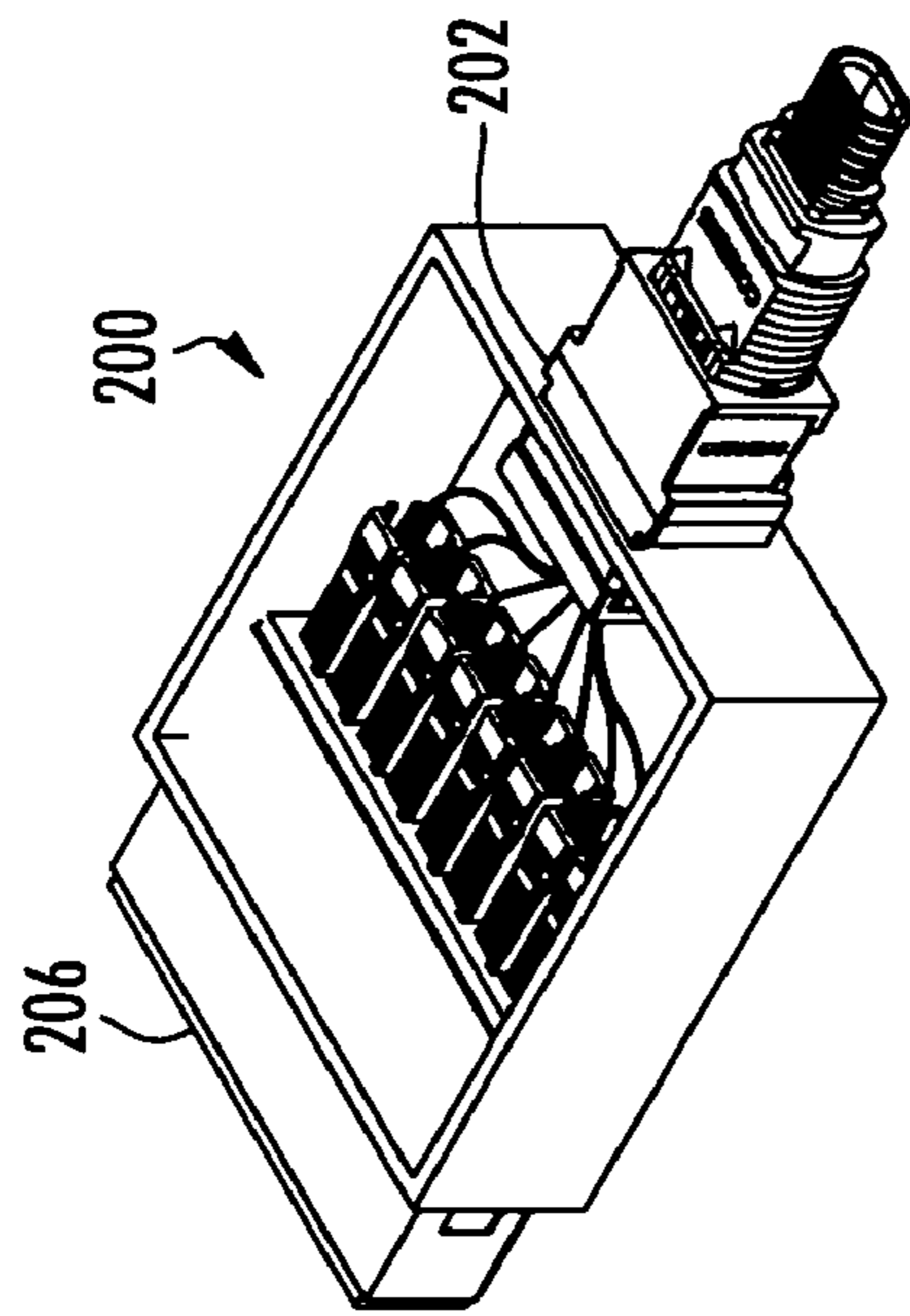


FIG. 11A

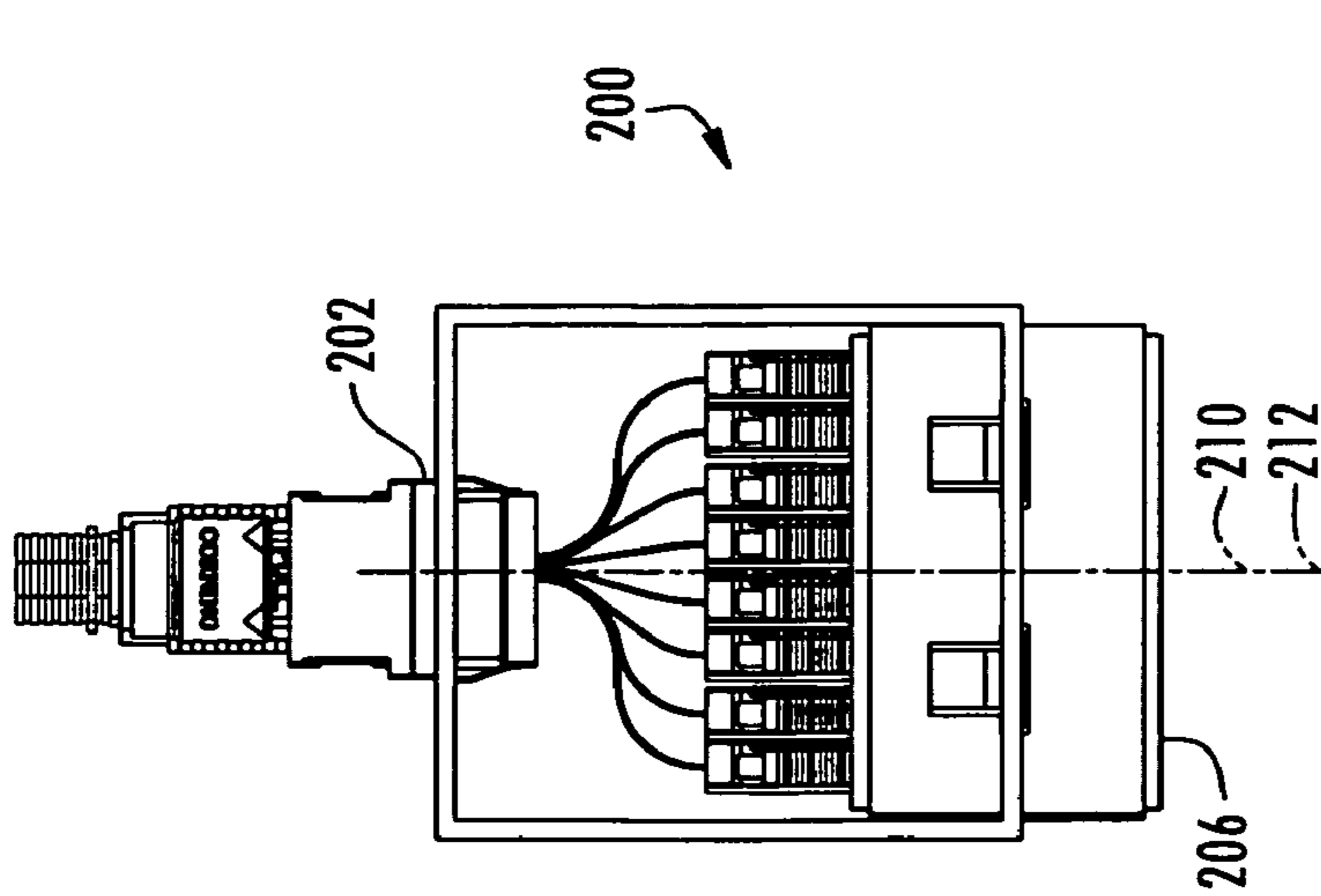


FIG. 11B

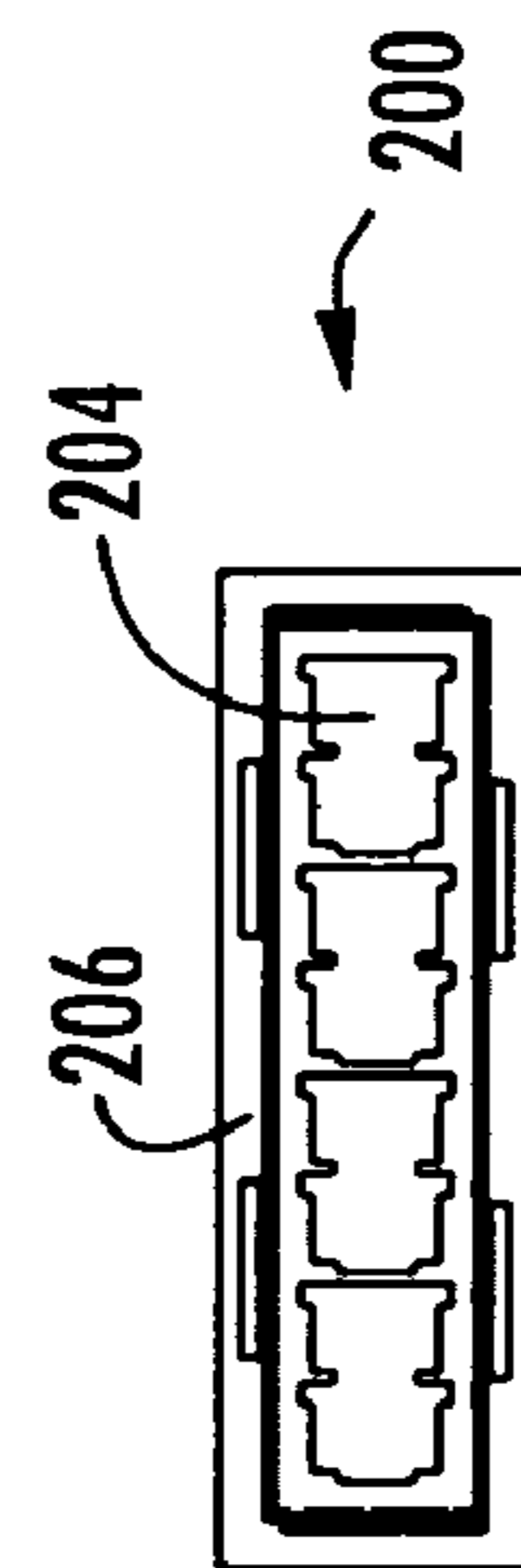


FIG. 11C

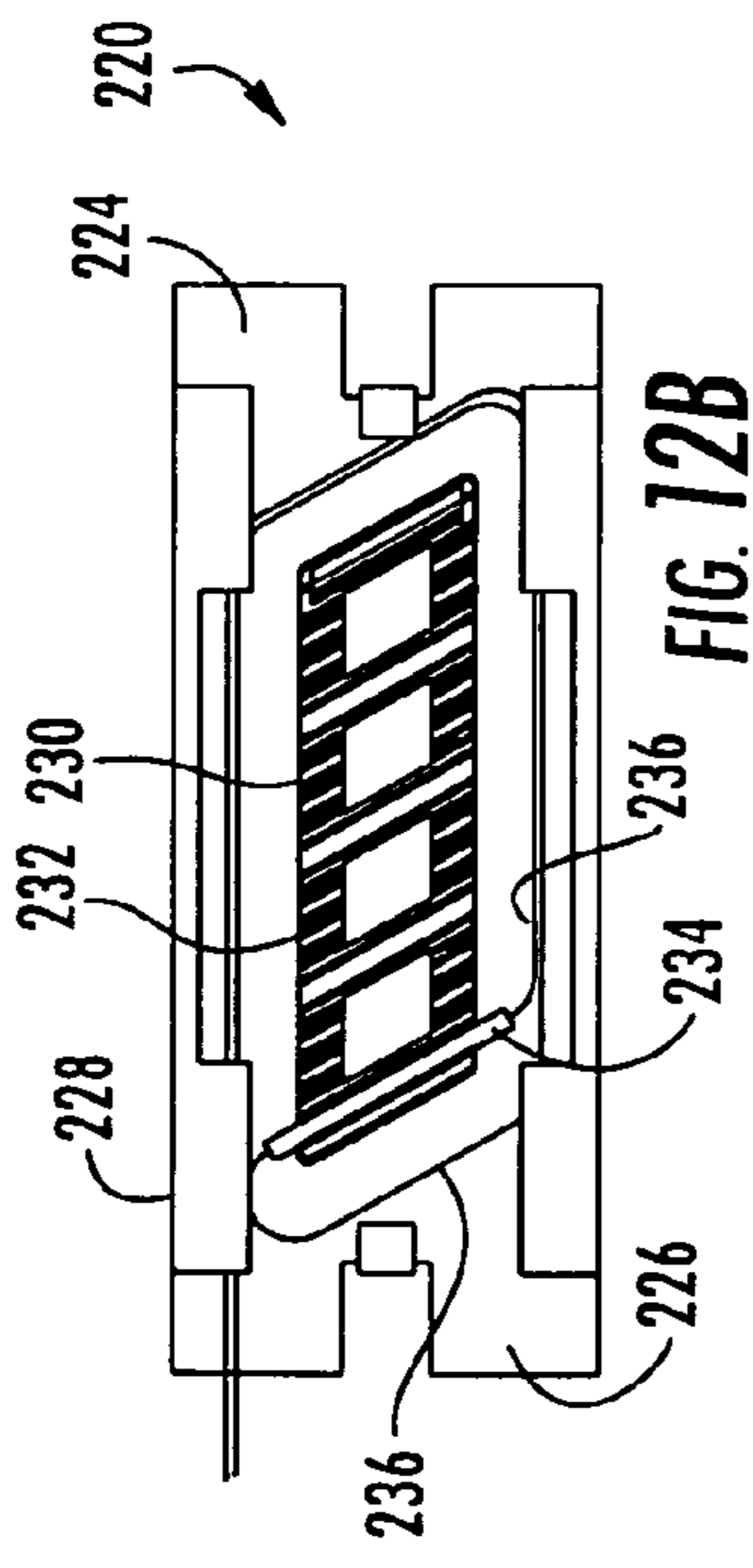


FIG. 12B

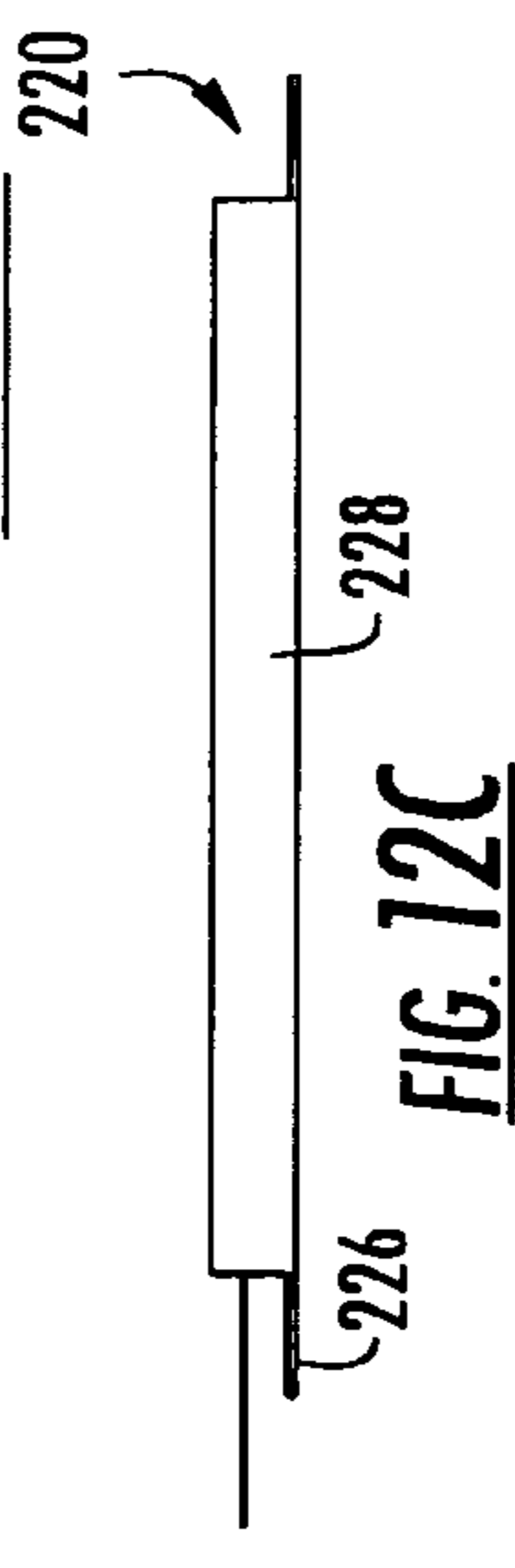


FIG. 12C

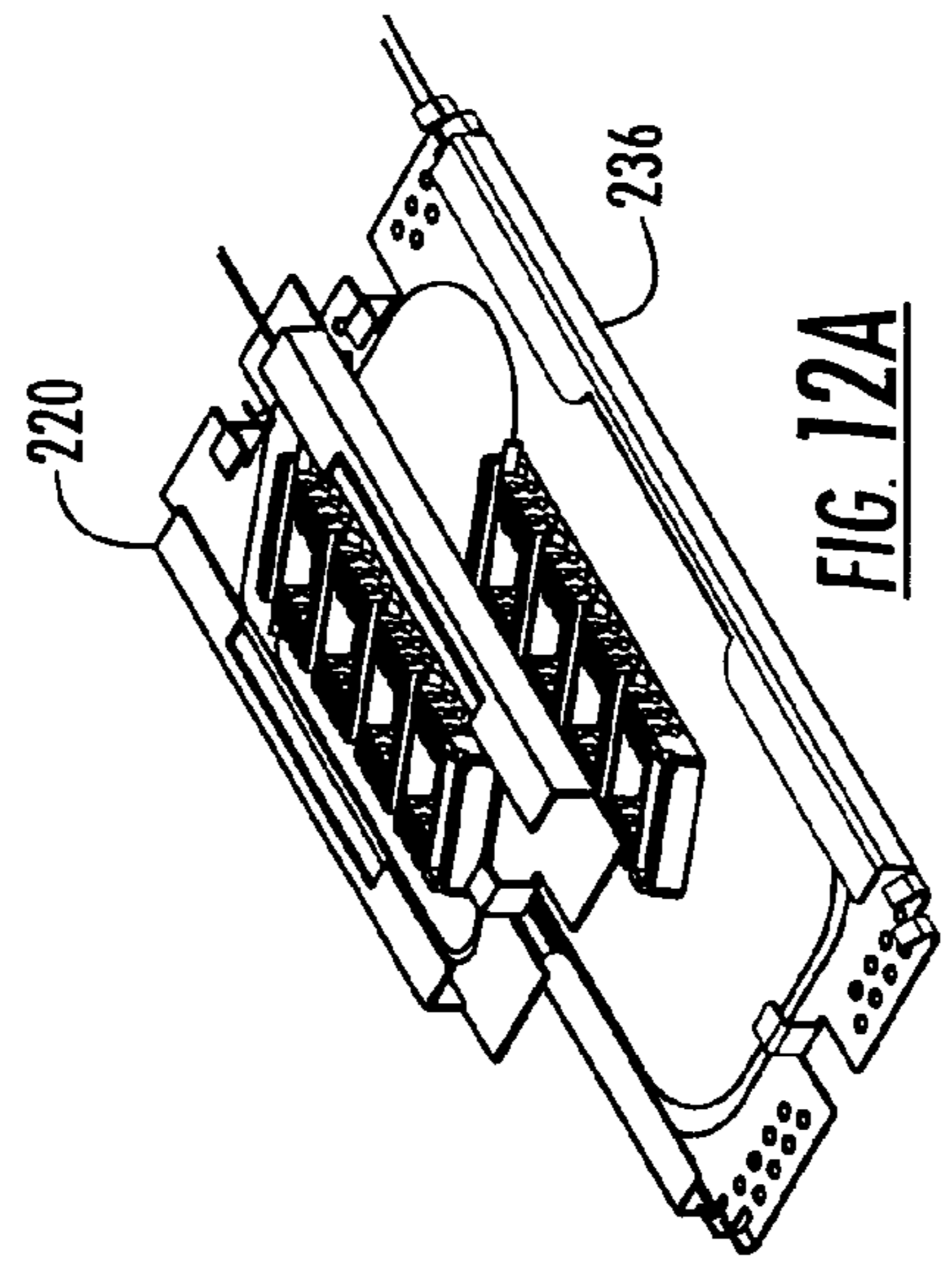


FIG. 12A

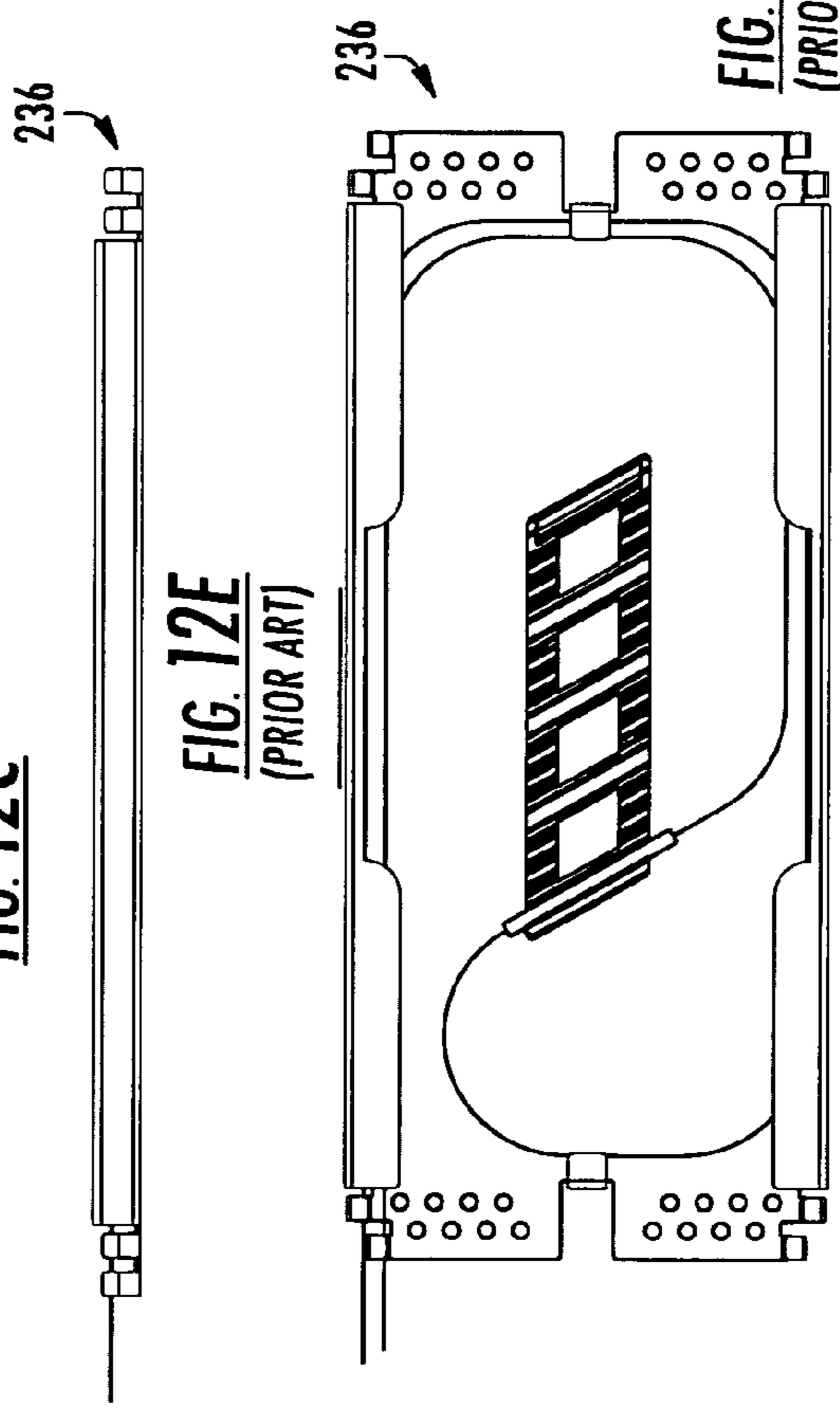
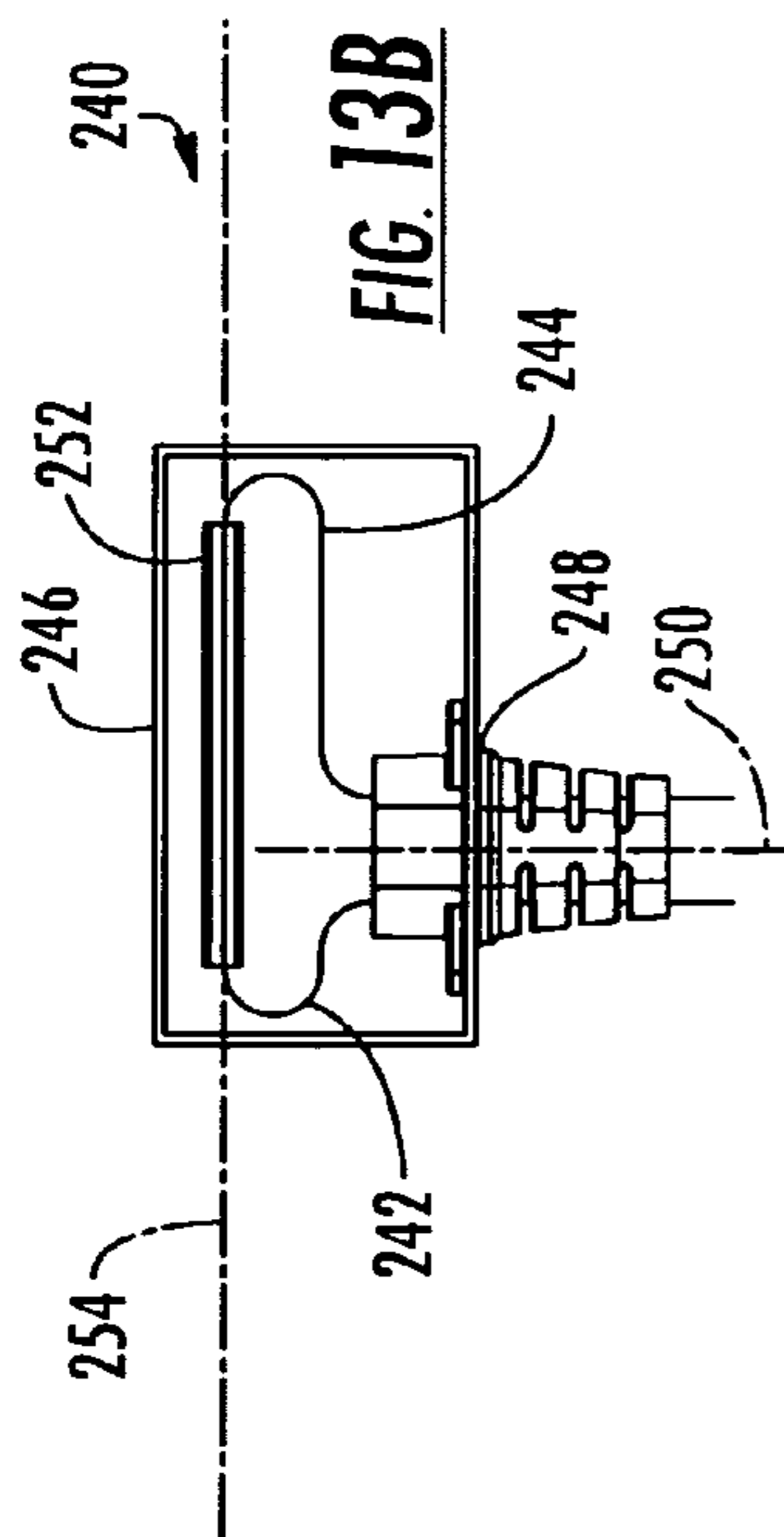


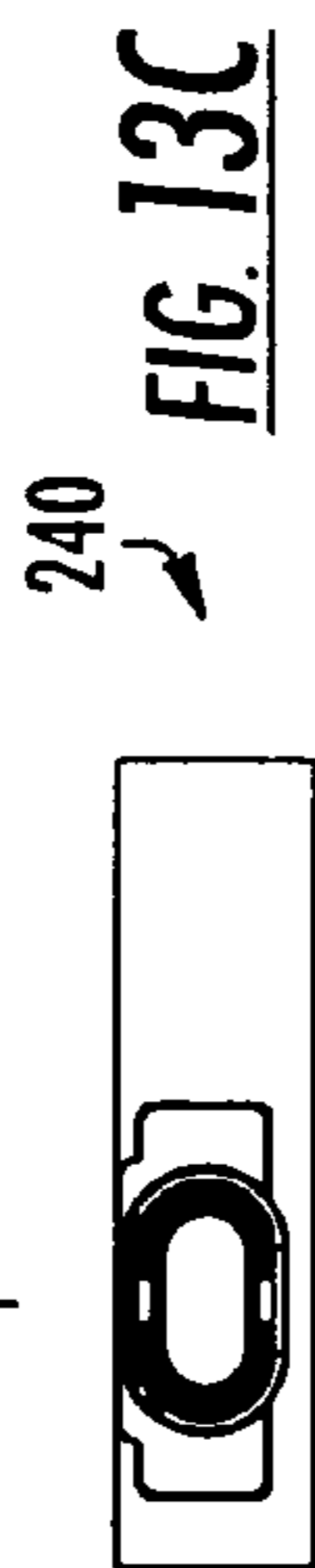
FIG. 12E  
(PRIOR ART)

FIG. 12D  
(PRIOR ART)





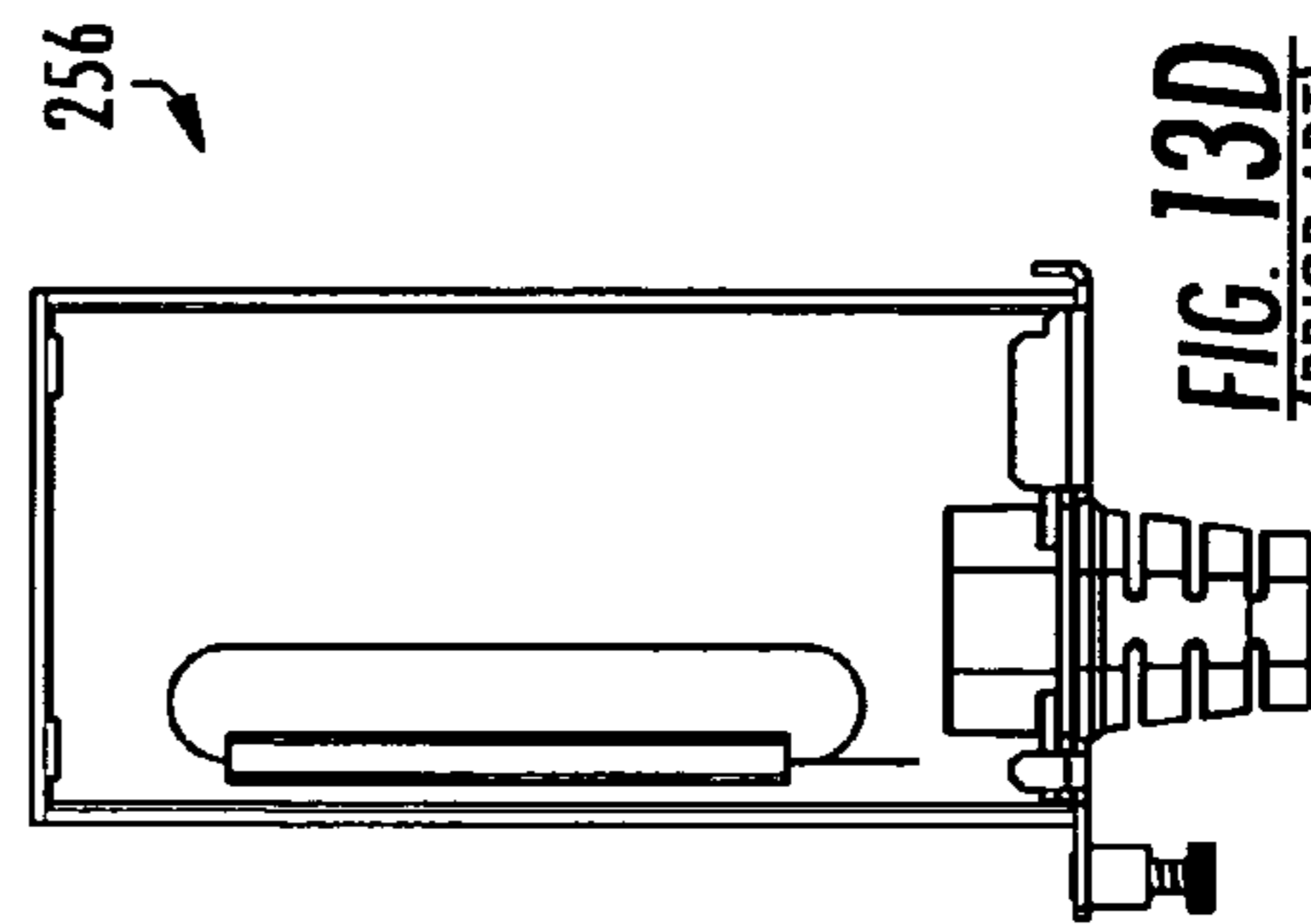
**FIG. 13B**



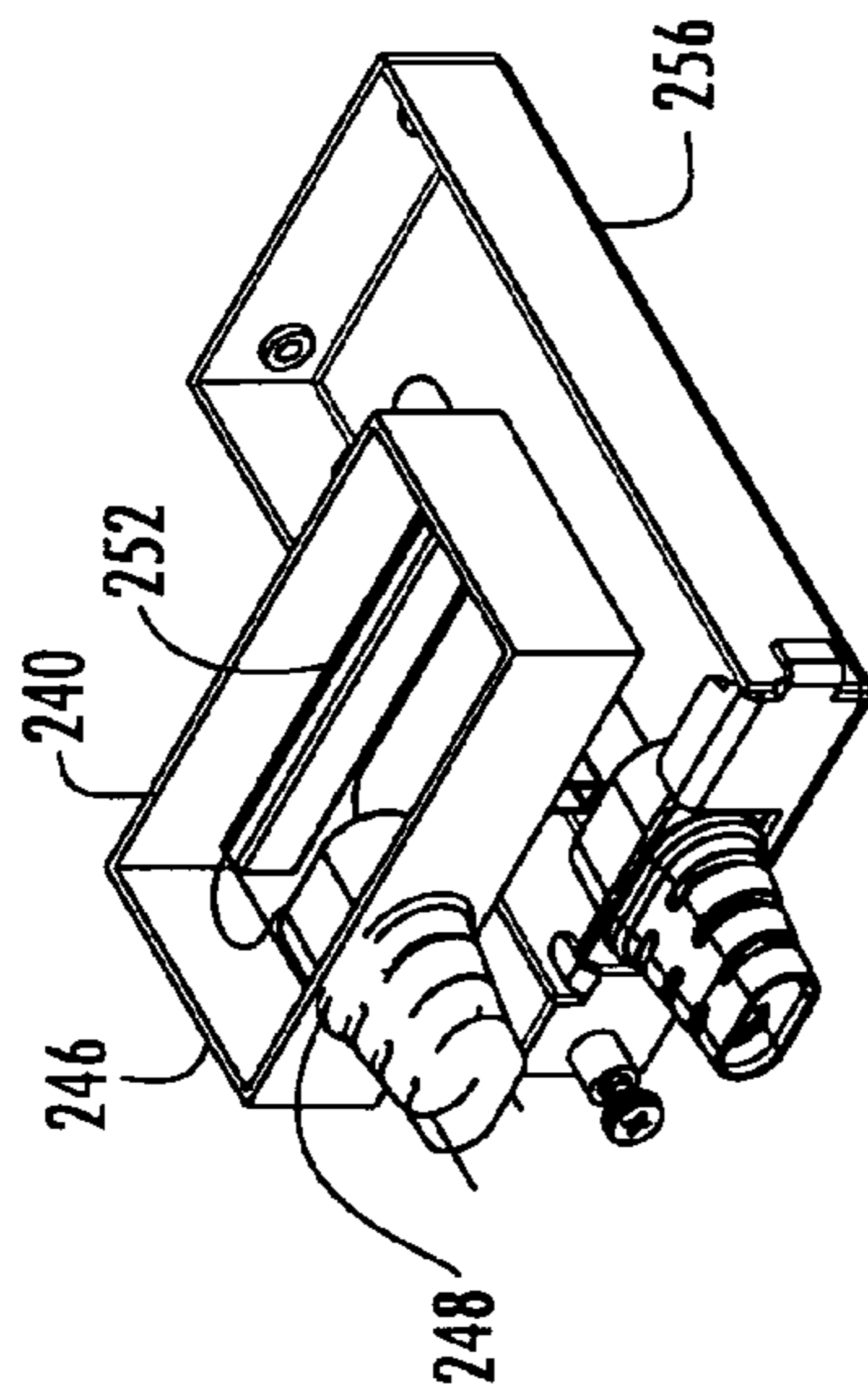
**FIG. 13C**



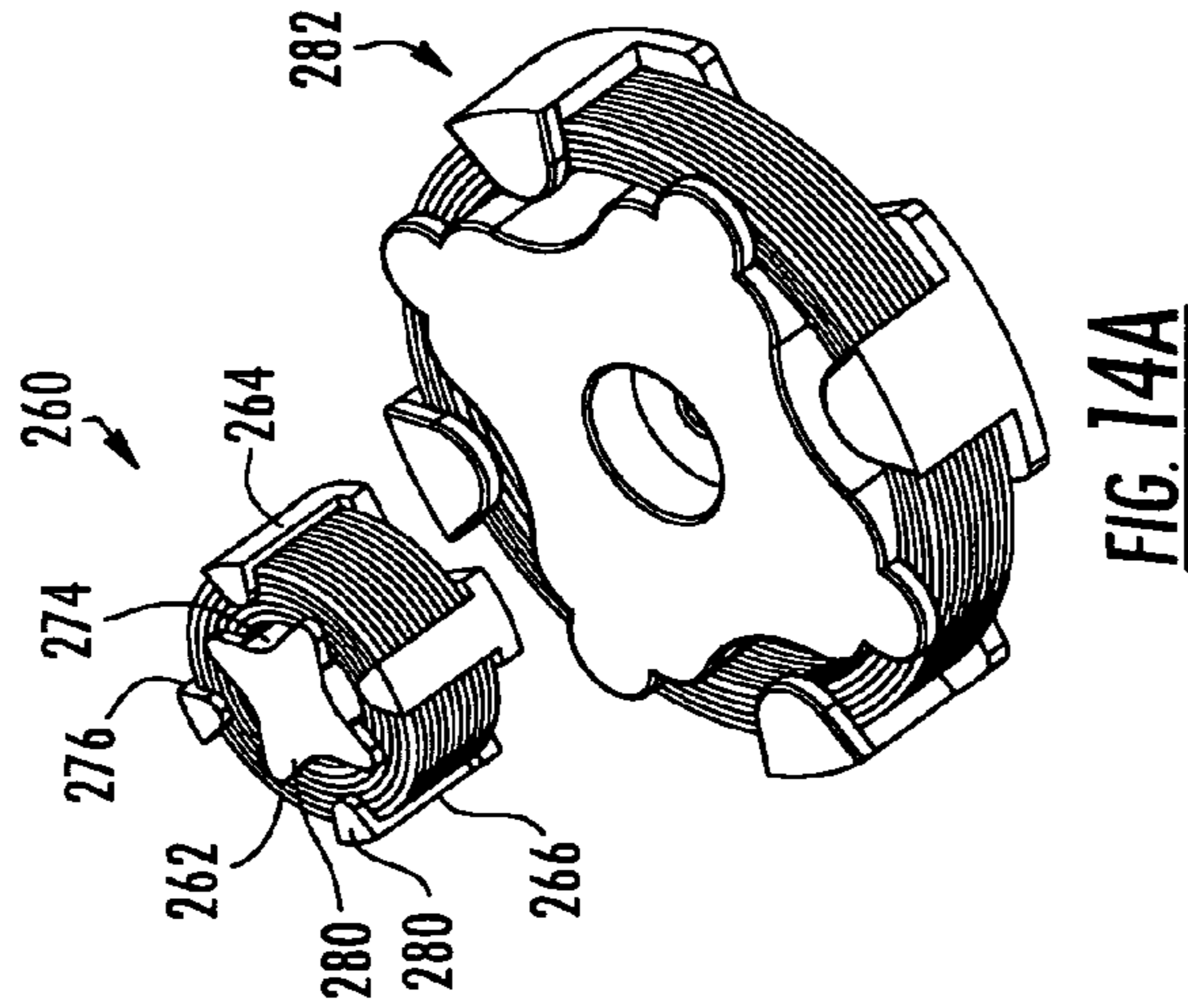
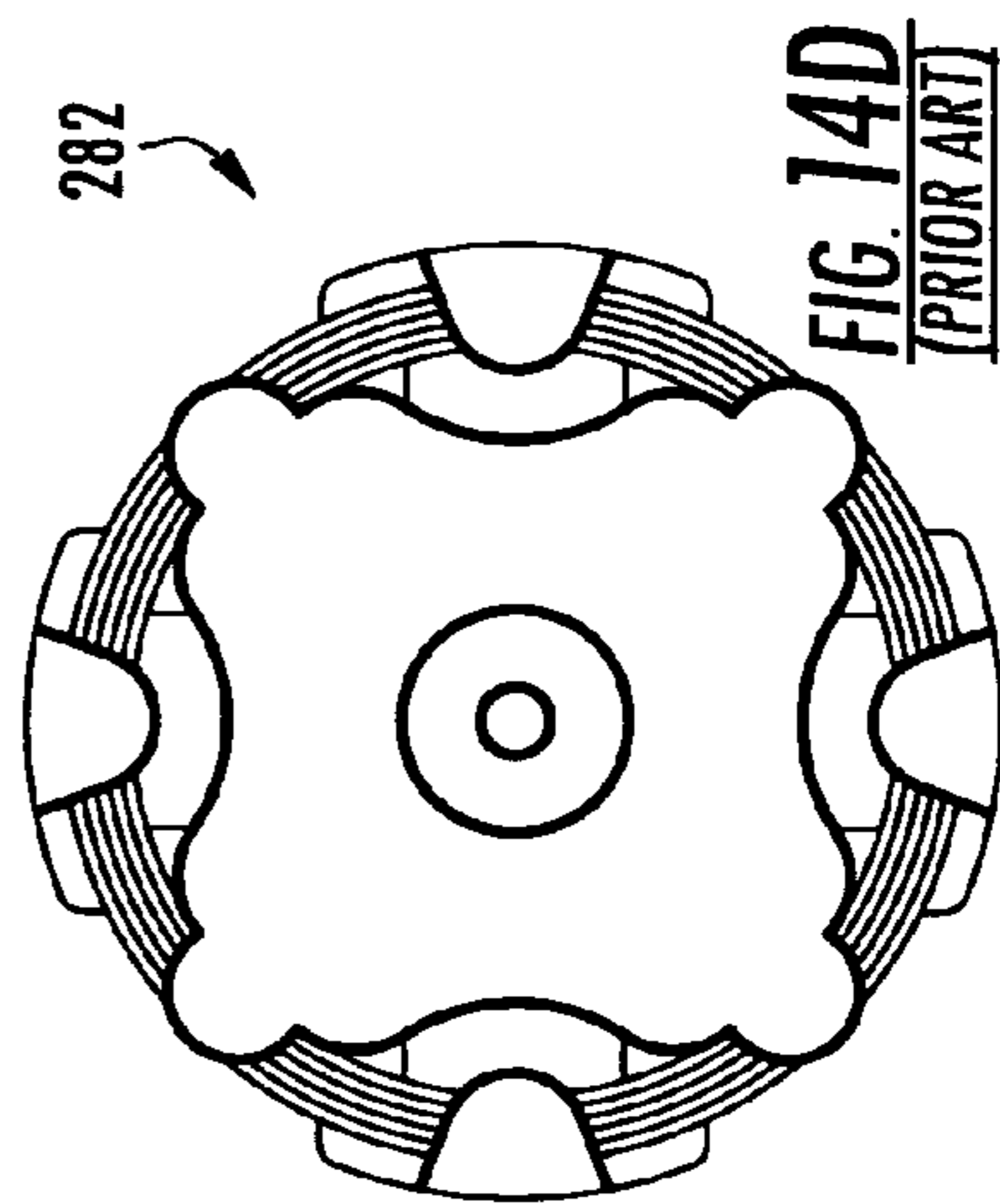
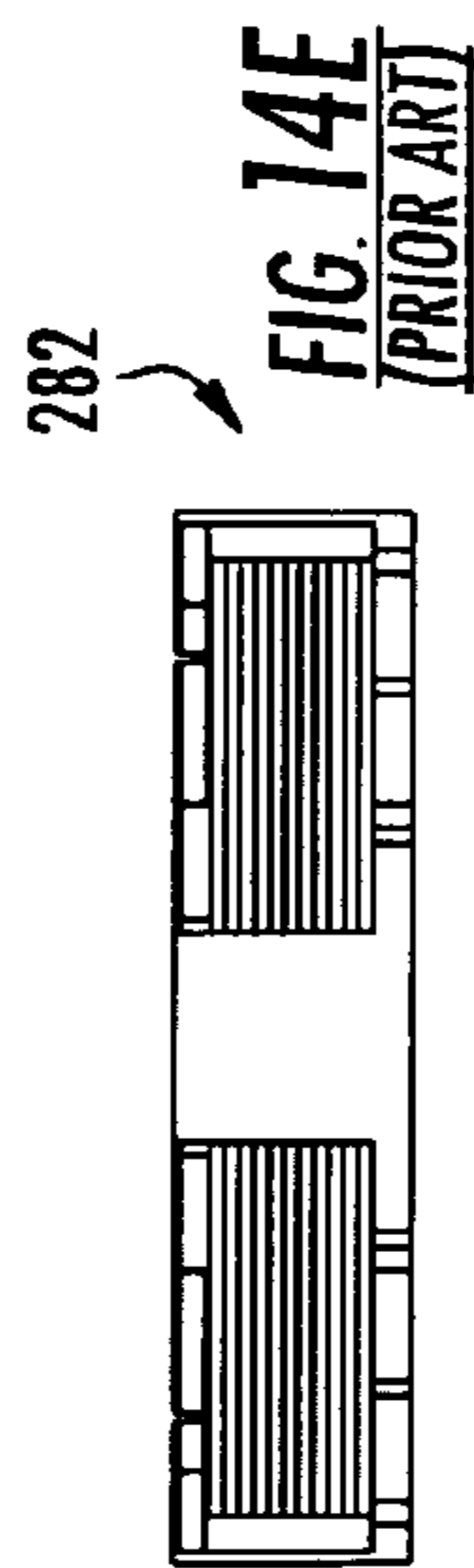
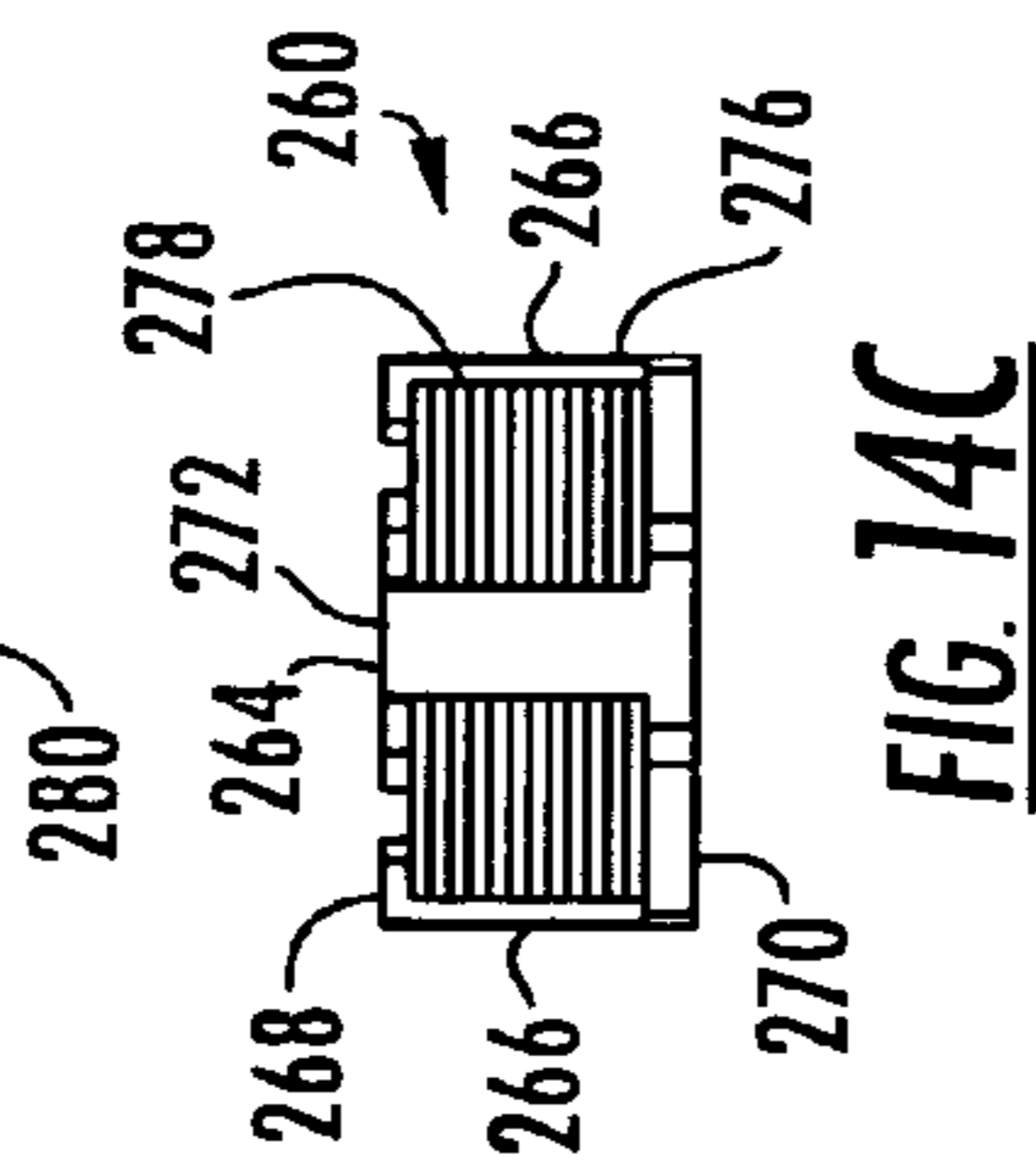
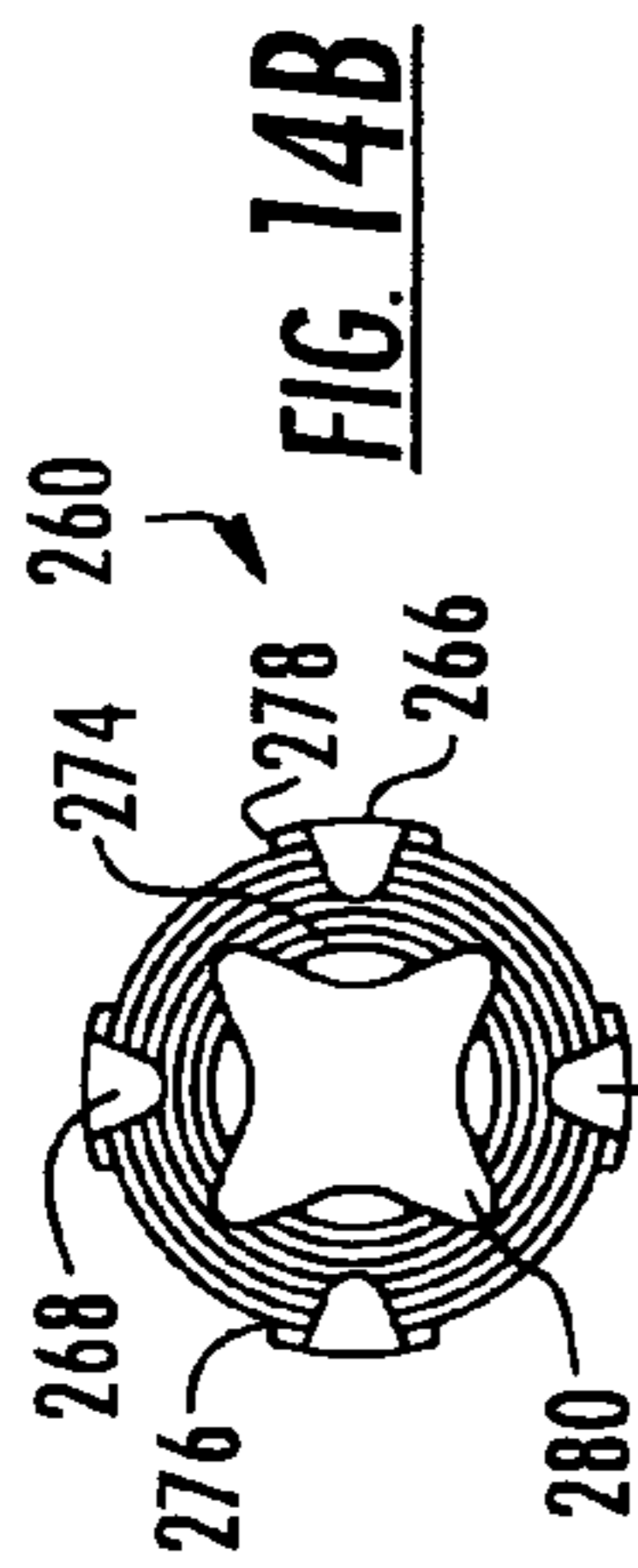
**FIG. 13E**  
**(PRIOR ART)**



**FIG. 13D**  
**(PRIOR ART)**



**FIG. 13A**



## FIBER OPTIC LOCAL CONVERGENCE POINTS FOR MULTIPLE DWELLING UNITS

**Matter enclosed in heavy brackets [ ] appears in the original patent but forms no part of this reissue specification; matter printed in italics indicates the additions made by reissue; a claim printed with strikethrough indicates that the claim was canceled, disclaimed, or held invalid by a prior post-patent action or proceeding.**

*More than one reissue application has been filed for the reissue of U.S. Pat. No. 7,548,680. The reissue applications are U.S. patent application Ser. No. 13/162,115 (issued as U.S. Pat. No. RE46,701 on Feb. 6, 2018); Ser. No. 14/028,338 (issued as U.S. Pat. No. RE46,525 on Aug. 29, 2017); and U.S. patent application Ser. No. 15/715,694. U.S. patent application Ser. No. 15/715,694 is the present application and is a continuation reissue application of U.S. patent application Ser. No. 13/162,115.*

### RELATED APPLICATIONS

The present application is a *continuation reissue application of U.S. patent application Ser. No. 13/162,115, filed Jun. 16, 2011, which is an application for reissue of U.S. Pat. No. 7,548,680, issued Jun. 16, 2009, which is a Continuation of U.S. Ser. No. 11/653,137, filed on Jan. 12, 2007, now U.S. Pat. No. 7,349,616, each of which is incorporated herein by reference.*

### BACKGROUND OF THE INVENTION

#### 1. Field of the Invention

The present invention is related to fiber optic local convergence points and associated fiber optic hardware, and more particularly, to fiber optic local convergence points adapted for multiple dwelling units.

#### 2. Description of Related Art

To provide improved performance to subscribers, fiber optic networks are increasingly providing optical fiber connectivity directly to the subscribers. As part of various fiber-to-the-premises (FTTP), fiber-to-the-home (FTTH), and other initiatives (generally described as FTTX), such fiber optic networks are providing the optical signals from distribution cables through local convergence points ("LCPs") to fiber optic cables, such as drop cables, that are run directly to the subscribers' premises. Such optical connectivity is increasingly being provided to multiple dwelling units ("MDUs") in part because of the relatively large density of subscribers located in an MDU.

MDUs include apartments, condominiums, townhouses, dormitories, hotels/motels, office buildings, factories, and any other collection of subscriber locations that are in relatively close proximity to one another. MDUs typically are all provided in a single indoor environment, such as an office or condominium; however, MDUs may also include a plurality of individual structures, such as apartment complexes. Typically, if an MDU comprises multiple structures, the optical fibers extending between the structures are adapted for outdoor environments, whereas the optical fibers extending within the structures are adapted for indoor environments. Most conventional MDUs include an LCP located in a generally central and selectively accessible location, such as the basement, utility closet, or the like, or the LCP may be located outside the MDU on an exterior wall, in a

pedestal, in a handhole, or the like. The LCP includes at least one fiber optic cable that optically connects to a distribution cable. The LCP also includes a connection point where the subscriber cables routed through the building are optically connected to the distribution cable.

Conventional LCPs for such MDUs are generally sized according to the number of subscribers to be serviced through the LCP, and many of the high density MDUs require large, expensive LCPs that may be difficult to install and/or transport. In addition, conventional LCPs often require skilled technicians to install the LCP and route the associated subscriber cables. Furthermore, highly skilled technicians are required to optically connect, often by splicing, the distribution cable to the LCP and to optically connect and route the subscriber cables to the LCP. Therefore, a need exists for LCPs that are cost-effective, are relatively small in size, and may be installed and maintained by relatively unskilled technicians.

### BRIEF SUMMARY OF THE INVENTION

The various embodiments of the present invention address the above needs and achieve other advantages by providing LCPs and associated fiber optic hardware components that provide optical connectivity to relatively large numbers of subscribers using relative small fiber optic hardware components. In addition, some embodiments of the present invention enable installation of the LCPs and associated components by relatively unskilled technicians by removing the need to splice any of the connections between the distribution cable and the subscriber location and by providing optical fibers having significantly smaller minimum bend radii to provide more versatility when routing the subscriber cables through the building.

In one embodiment of the present invention, a fiber optic local convergence point ("LCP") adapted for use with a multiple dwelling unit is provided. The LCP is adapted to optically connect at least one optical fiber of a distribution cable to at least one subscriber optical fiber. The LCP comprises a housing having an interior cavity defined by a plurality of sides and by a cover that is selectively moveable from an opened position to a closed position to thereby provide access to the interior cavity when the cover is in the opened position. The housing also includes at least one surface adapted for mounting the LCP to a structure, and the housing further comprises at least one opening through the housing for the passage of at least one optical fiber. The LCP also comprises a cable assembly with a connector end adapted for optical connection to the at least one optical fiber of the distribution cable and with a splitter end generally opposite the connector end of the cable assembly. The splitter end of the cable assembly defines a casing with an exterior surface that defines a plurality of receptacles adapted to selectively receive fiber optic connectors that are optically connected to the subscriber optical fiber. The connector end of the cable assembly is optically connected to the splitter end with at least one cable assembly optical fiber. In addition, the splitter end comprises at least one splitter that optically connects the cable assembly optical fiber with the plurality of receptacles. The splitter end of the cable assembly is adapted to be removably received within the housing of the LCP, and the splitter end is adapted to be received within the housing without opening the casing of the splitter end.

Further embodiments of the present invention provide a cable assembly adapted for use in a multiple dwelling unit to optically connect at least one optical fiber of a distribution

cable to at least one subscriber optical fiber. The cable assembly comprising a connector end adapted for optical connection to the at least one optical fiber of the distribution cable and with a splitter end generally opposite the connector end of the cable assembly. The splitter end of the cable assembly defines a casing with an exterior surface that defines a plurality of receptacles adapted to selectively receive fiber optic connectors that are optically connected to the subscriber optical fiber. The connector end of the cable assembly is optically connected to the splitter end with at least one cable assembly optical fiber. In addition, the splitter end comprises at least one splitter that optically connects the cable assembly optical fiber with the plurality of receptacles. Some embodiments of the present invention include at least one microstructured optical fiber in the cable assembly. The microstructured optical fiber comprises a core region and a cladding region surrounding the core region, the cladding region comprises an annular hole-containing region comprised of non-periodically disposed holes. The microstructured fiber of some embodiments of the present invention has an 8 mm macrobend induced loss at 1550 nm of less than 0.2 dB/turn.

Still further embodiments provide related fiber optic hardware adapted for use in MDUs and other facilities. For example, the present invention provides fiber optic splice tray assemblies defining a density of splice holders per unit of volume of the splice tray assembly of at least 5 single splices/in<sup>3</sup> and/or at least 10 mass fusion splices/in<sup>3</sup>, fiber optic splitter modules that includes a splitter axis orthogonal to an opening axis and/or that define a density of splits per unit volume of the housing of at least 5 splits/in<sup>3</sup>, fiber optic routing guides adapted to store an amount of length of optical fiber (900 μm diameter) per unit of volume of a housing of at least 10 in/in<sup>3</sup>, and fiber distribution terminals ("FDTs") defining a density of fiber optic output receptacles per unit of volume of the housing of at least 10 receptacles/in<sup>3</sup> for an input subscriber optical cable and of at least 6 receptacles/in<sup>3</sup> for a connectorized input subscriber optical cable. All of these fiber optic hardware components provide a significant improvement to the comparable conventional components, thus allowing them to be more easily handled and allowing them to be installed in a greater number of locations based upon the network's requirements and/or the technician's preferences. Therefore, the LCPs, cable assemblies, FDTs, and other components of various embodiments of the present invention provide for cost-effective, reduced-size, and easily-installed fiber optic networks for MDUs.

#### BRIEF DESCRIPTION OF THE SEVERAL VIEWS OF THE DRAWINGS

Having thus described the invention in general terms, reference will now be made to the accompanying drawings, which are not necessarily drawn to scale and are meant to be illustrative and not limiting, and wherein:

FIG. 1A is a perspective view of a local convergence point ("LCP") in accordance with one embodiment of the present invention with the cover removed and the splitter end of the cable assembly opened;

FIG. 1B is a top view the LCP of FIG. 1A illustrating the optical fiber routing within the splitter end of the cable assembly and illustrating the subscriber optical fiber;

FIG. 1C is a side view of the bottom of the LCP of FIG. 1A illustrating the openings for the at least one cable assembly optical fiber (left) and the at least one subscriber optical fiber (right);

FIG. 2A is a perspective view of a LCP in accordance with another embodiment of the present invention, illustrating the housing of the LCP removably receiving the splitter end of the cable assembly by rotating the splitter end into the housing;

FIG. 2B is a top view of the LCP of FIG. 2A illustrating the splitter end of the cable assembly at a rotated position;

FIG. 2C is a bottom view of the LCP of FIG. 2A illustrating the splitter end of the cable assembly at a rotated position of about 45 degrees;

FIG. 3A is a perspective view of a LCP in accordance with yet another embodiment of the present invention, illustrating the housing as including a plurality of splitter modules, a splice tray assembly, fiber optic routing guides, and a subscriber termination field comprising a plurality of receptacles, wherein the LCP is free of a splitter end of a cable assembly;

FIG. 3B is a perspective view of the LCP of FIG. 3A with a cover attached and in the closed position;

FIG. 3C is a top view of the LCP of FIG. 3A illustrating the splitter modules, the splice tray assembly, the fiber optic routing guides, and the subscriber termination field;

FIG. 4A is a perspective view of a LCP in accordance with a further embodiment of the present invention, illustrating the splitter end of the cable assembly as including a plurality of splitter modules, a splice tray assembly, fiber optic routing guides, and a subscriber termination field comprising a plurality of receptacles;

FIG. 4B is a top view of the LCP of FIG. 4A illustrating the splitter modules, the splice tray assembly, the fiber optic routing guides, and the subscriber termination field within the splitter end of the cable assembly;

FIG. 5A is a perspective view of a LCP in accordance with a still further embodiment of the present invention, illustrating a plurality of splitter modules housed within the interior cavity of the housing, wherein the splitter modules define multi-fiber output receptacles;

FIG. 5B is a perspective view of the LCP of FIG. 5A illustrating the splitter modules with the access cover removed to allow selective installation and/or removal of the individual splitter modules;

FIG. 5C is a top view of the LCP of FIG. 5A with the access cover installed;

FIG. 5D is a side view of the bottom of the LCP of FIG. 5A illustrating the openings providing passage for the optical fibers to and from the distribution cable and/or the subscriber termination points;

FIG. 6 is a side view of a MDU that includes an LCP and associated fiber optic hardware in accordance with another embodiment of the present invention wherein the fiber optic network does not include at least one FDT such that the subscriber optical fibers are routed directly to the subscriber termination points without the use of the FDT and/or the subscriber drop optical fibers;

FIG. 7 is a side view of a multiple dwelling unit ("MDU") that includes an LCP and associated fiber optic hardware in accordance with one embodiment of the present invention, illustrating the optical signal routing from the distribution cable to LCP via the cable assembly optical fiber to the LCP, then to the FDT via the subscriber optical fiber, and finally to the subscriber termination point via the subscriber drop optical fiber;

FIG. 8A is a perspective view of a fiber distribution terminal ("FDT") in accordance with one embodiment of the present invention illustrating a single input optical cable

5

comprising a plurality of input optical fibers and an output opening comprising a plurality of fiber optic output receptacles;

FIG. 8B is a perspective view of the FDT of FIG. 8A further comprising a removable portion adapted to selectively cover the fiber optic output receptacles when at least one connector is received in the fiber optic receptacles;

FIG. 8C is a top view of the FDT of FIG. 8A illustrating the mounting flanges of the FDT;

FIG. 8D is a side view of the bottom of the FDT of FIG. 8A illustrating the input opening in a sidewall as comprising a through-hole for passage of at least one input optical fiber;

FIG. 9A is a perspective view of a FDT in accordance with a further embodiment of the present invention illustrating an input opening comprising a fiber optic input receptacle and an output opening comprising a plurality of fiber optic output receptacles;

FIG. 9B is a top view of the FDT of FIG. 9A illustrating the mounting flanges of the FDT;

FIG. 9C is a side view of the bottom of the FDT of FIG. 9A illustrating the input opening in a sidewall as comprising a fiber optic input receptacle adapted to receive a multi-fiber connector of the subscriber optical fiber;

FIG. 10A is a perspective view of a FDT in accordance with a still further embodiment of the present invention with a top cover removed, illustrating an input opening comprising a fiber optic input receptacle and an output opening comprising a plurality of fiber optic output receptacles, wherein the FDT defines an input opening axis that is generally orthogonal to an output opening axis;

FIG. 10B is a top view of the FDT of FIG. 10A illustrating the internal routing of the optical fibers from the input opening to the output opening;

FIG. 10C is a side view of the output opening of the FDT of FIG. 10A illustrating the plurality of fiber optic output receptacles adapted to receive MU connectors of the subscriber drop optical fibers;

FIG. 11A is a perspective view of a FDT in accordance with yet another embodiment of the present invention with a top cover removed, illustrating an input opening comprising a fiber optic input receptacle and an output opening comprising a plurality of fiber optic output receptacles, wherein the FDT defines an input opening axis that is generally parallel to an output opening axis;

FIG. 11B is a top view of the FDT of FIG. 11A illustrating the internal routing of the optical fibers from the input opening to the output opening;

FIG. 11C is a side view of the output opening of the FDT of FIG. 11A illustrating the plurality of fiber optic output receptacles adapted to receive MU connectors of the subscriber drop optical fibers;

FIG. 12A is a perspective view of a fiber optic splice tray assembly in accordance with one embodiment of the present invention illustrated above a prior art splice tray assembly, wherein the splice tray assembly of the present invention defines a significantly greater density of splice holders per unit volume of the splice tray assembly as compared to the prior art splice tray assembly;

FIGS. 12B and 12C are top and side views, respectively, of the splice tray assembly of the embodiment of the present invention of FIG. 12A illustrated to scale relative to the prior art splice tray assembly of FIGS. 12D and 12E;

FIGS. 12D and 12E are top and side views, respectively, of the prior art splice tray assembly of FIG. 12A illustrated to scale relative to the splice tray assembly of FIGS. 12B and 12C;

6

FIG. 13A is a perspective view of a fiber optic splitter module in accordance with one embodiment of the present invention illustrated above a prior art splitter module, wherein the splitter module of the present invention defines a significantly greater density of output optical fibers per unit volume of the housing as compared to the prior art splice tray assembly, and wherein the splitter module of the present invention defines a splitter axis that is generally orthogonal to an opening axis;

FIGS. 13B and 13C are top and side views, respectively, of the splitter module of the embodiment of the present invention of FIG. 13A illustrated to scale relative to the prior art splitter module of FIG. 13A;

FIGS. 13D and 13E are top and side views, respectively, of the prior art splitter module of FIG. 13A illustrated to scale relative to the splitter module of FIGS. 13B and 13C;

FIG. 14A is a perspective view of a fiber optic routing guide in accordance with one embodiment of the present invention illustrated above a prior art routing guide, wherein the routing guide of the present invention is adapted to store a significantly greater amount of length of optical fiber per unit volume of the housing as compared to the prior art routing guide;

FIGS. 14B and 14C are top and side views, respectively, of the routing guide of the embodiment of the present invention of FIG. 14A illustrated to scale relative to the prior art routing guide of FIG. 14A; and

FIGS. 14D and 14E are top and side views, respectively, of the prior art routing guide of FIG. 14A illustrated to scale relative to the routing guide of FIGS. 14B and 14C.

#### DETAILED DESCRIPTION OF THE INVENTION

The present invention now will be described more fully hereinafter with reference to the accompanying drawings, in which some, but not all embodiments of the invention are shown. Indeed, the invention may be embodied in many different forms and should not be construed as limited to the embodiments set forth herein; rather, these embodiments are provided so that this disclosure will satisfy applicable legal requirements. Although apparatus and methods for providing local convergence points ("LCPs") for multiple dwelling units ("MDUs") are described and shown in the accompanying drawings with regard to specific types of LCPs and associated fiber optic hardware, it is envisioned that the functionality of the various apparatus and methods may be applied to any now known or hereafter devised LCPs and associated fiber optic hardware in which it is desired to provide optical connectivity for MDUs. Like numbers refer to like elements throughout.

With reference to FIG. 1A-14E, various LCPs and associated fiber optic hardware in accordance with various embodiments of the present invention are illustrated. It should be appreciated that the many embodiments of the present invention include various combinations of the fiber optic hardware described herein. Furthermore, certain embodiments to not include all of the components described herein, non-limiting examples of components that are not included in all embodiments include fiber optic splice tray assemblies, fiber optic routing guides, fiber distribution terminals, subscriber drop optical fibers, and others. In addition, although many embodiments referred to herein are described as having certain dimensions and densities, it should be appreciated that the dimensions are merely exemplary and limiting.

Turning now to the LCP **10** of FIGS. **1A-1C**, the LCP is adapted for use with a MDU to optically connect at least one optical fiber of a distribution cable to at least one subscriber optical fiber. The LCPs described herein are intended for indoor use; however, further embodiments are adapted for indoor and/or outdoor use and may be mounted to any surface. The LCP **10** of FIGS. **1A-1C** include a housing **12** comprising an interior cavity **14** defined by a plurality of sides **16** and by a cover (not shown) that is selectively moveable from an opened position to a closed position to thereby provide access to the interior cavity when the cover is in the opened position. The interior cavity **14** of the LCP **10** is not hermetically sealed and may include a variety of openings to provide access to the interior cavity. The housing **12** of FIGS. **1A-1C** comprises at least one surface **16** adapted for mounting the LCP **10** to a structure (not shown) such as wall in a building to provide one non-limiting example. The housing **12** of FIGS. **1A-1C** is similar to standard plastic network interface device ("NID") housings offered by Corning Cable Systems of Hickory, N.C.; however, the housings of further embodiments of the present inventions include housings of any shape and/or material sufficient to provide the necessary optical connectivity, environmental protection, and/or structural properties required for the particular application. The housing **12** further comprises at least one opening **18** and **20** through the housing for the passage of at least one optical fiber such as an optical fiber **22** optically connected to at least one optical fiber of a distribution cable (not shown) and such as a subscriber optical fiber **24** optically connected to a subscriber termination point (not shown). It should be appreciated that the opening **20** provides passage for a plurality of subscriber optical fibers which are shown generally outside the housing **12**, but for illustrative purposes only one subscriber optical fiber **24** is shown inside the housing **12**.

The LCP **10** of FIGS. **1A-1C** also includes a cable assembly **30** comprising a connector end (not shown) adapted for optical connection to at least one optical fiber of a distribution cable (not shown) of the fiber optic network. The connector end includes a preconnectorized (factory-prepared connector) end that may be conveniently connected to a connector at an access point on the distribution cable. Conversely, the connector end of further embodiments may not include any connector such that the optical fiber(s) of the connector end must be spliced to the optical fiber(s) of the distribution cable at an access point (that may or may not be factory-prepared) on the distribution cable. Returning again to the embodiment of FIGS. **1A-1C**, generally opposite the connector end of the cable assembly **30** is provided a splitter end **32** that defines a casing **34** with an exterior surface **36** that defines a plurality of receptacles **38** adapted to selectively receive fiber optic connectors **40** that are optically connected to the at least one subscriber optical fiber **24**. At least one cable assembly optical fiber **22** extends from the connector end to the splitter end to optically connect the splitter end to the connector end (and the distribution cable when the LCP is installed).

The cable assembly optical fiber **22** of FIGS. **1A-1C** is optically connected to a splitter **42**, such as a 1×8, 1×16, 1×32, and/or 1×64 splitters to provide non-limiting examples of splitters, that splits the optical signal from the optical fiber **22** to a plurality of pigtails **44**. The pigtails **44** are optical fibers optically connected to the splitter and that terminate in a connector (not shown) adapted to be received in the receptacles opposite the exterior surface **36**, such that receipt of the fiber optic connector **40** by the receptacle **38** optically connects the pigtail to the subscriber optical fiber.

Further embodiments of the present invention provide alternative devices to optically connect the cable assembly optical fiber to the plurality of receptacles. The splitter end **32** of FIGS. **1A-1C** includes nine 1×32 splitters **42** thus providing up to 288 receptacles **38** adapted to selectively receive fiber optic connectors **40** that are optically connected to the at least one subscriber optical fiber **24**. Thus the cable assembly **30** includes nine cable assembly optical fibers to optically connect each of the splitters **42** to the distribution cable. However, further embodiments of the present invention include any number of cable assembly optical fibers, splitters, and receptacles, which are typically dictated by the number of subscriber termination points to be provided within the MDU (and the number of LCPs to be provided in the MDU, as some MDUs include multiple LCPs).

The splitter end **32** of the cable assembly **30** of the LCP **10** of FIG. **1A-1C** is adapted to be removably received within the housing **12** of the LCP. Furthermore, the splitter end **32** of FIGS. **1A-1C** is adapted to be received within the housing without opening the casing **34** of the splitter end. Therefore, the LCP **10** may be conveniently installed by a field technician by simply mounting the housing **12** to an appropriate surface, optically connecting the connector end of the cables assembly **30** to the distribution cable, and then inserting the splitter end **32** into the housing. Further embodiments of the present invention comprise an LCP that does not include a housing, but simply comprises the cable assembly, such as the cable assembly **30** of FIGS. **1A-1C**. Such use of a cable assembly without the housing would be suitable for certain applications where environmental protection, security, and other considerations are less of a concern. For certain embodiments of the LCP without a housing, the casing of the cable assembly includes features to assist in the convenient mounting of the splitter end (and in some embodiments, the connector end) of the cable assembly relative to the MDU.

Turning again to the LCP **10** of the illustrated embodiments, receipt of the splitter end **32** into the housing **12** is illustrated in FIGS. **2A-2C**. An interior surface of the housing **12** includes a clip **46** into which a protrusion of the casing **34** may be selectively received to create a hinge to allow the splitter end to be rotatably joined to the housing of the LCP **10**. To install the splitter end **32** into the housing **12**, the technician simply connects the protrusions to the respective clips **46** and then rotates the splitter end inward. The splitter end **32** is illustrated in FIGS. **2A-2C** as being at about a 45 degree angle relative to the housing; however, the splitter end may rotate any amount permitted by the housing (for this example from at least 0 degrees to 90 degrees); however, further embodiments of the present invention include splitter ends that rotate at any angles relative to the housing and splitter ends that are selectively received by the housing in alternative fashions, such as with fasteners, with retaining clips requiring linear insertion or alternative insertion techniques, with adhesives, and with any suitable retention devices and/or techniques. As previously mentioned, the splitter end **32** of FIGS. **1A-2C** is adapted to be received within the housing without opening the casing **34** of the splitter end. Furthermore, the splitter end of the cable assembly is adapted to be removably received within the housing **12** of the LCP **10** without requiring any splice operation and/or connectorization operation. The splitter end **32** is factory prepared to include all the necessary optical connectivity from the connector end to the plurality of receptacles such that a technician would not be required to open the casing **34**. However, it should be appreciated that the casings of some embodiments of the present invention

provide devices and/or techniques for selectively opening and closing the casing 34 in the field to permit selective access within the casing. Still further embodiments of the present invention include splitter ends that do not include any casing, such as the LCP 50 of FIGS. 3A-3B.

The LCP 50 of FIGS. 3A-3C is one embodiment of the present invention that does not include a casing for the splitter end 52. Rather than having an encased splitter end, the splitter end 52 of FIGS. 3A-3C is positioned within the interior cavity 54 as individual components, preferably in the factory, but possibly in the field. FIG. 3B illustrates the cover 56 that is selectively movable from an opened position to a closed position (FIG. 3B) to provide access to the interior cavity 54. The splitter end 52 of the LCP 50 may be factory prepared to include all the fiber optic hardware components shown and to allow a field technician to provide a number of operations on the various components. The splitter end 52 includes a plurality of splitters 58, at least one splice tray assembly 60, at least one fiber optic routing guide 62, and a subscriber termination field comprising a plurality of receptacles 64. By providing the fiber optic hardware components individually within the LCP 50, a network provider is given the option of purchasing the LCP with the minimum amount of fiber optic hardware components required at the time of installation and then add additional components as additional subscribers need connection to the network. Still further advantages are provided by providing the splitter end 52 of FIGS. 3A-3C. The cable assembly optical fiber(s) (not shown) is routed to the splitters 58 where the optical signal is split into a plurality of optical fibers. The optical fibers may be spliced, by either single splices for individual fibers or mass fusion splicing for multi-fiber cables such as ribbon cables, and placed within the splice tray assembly. The optical fibers from the splitters may be spliced to pigtails that may be inserted into a side of the receptacles 64 opposite the side into which the connector of the subscriber optical fiber will be received. Although the splice tray assembly 60 does accommodate a certain amount of fiber optic slack, such as an amount of slack necessary to perform the splice operation, the fiber optic routing guides 62 also provide slack storage for the optical fibers from the splitters and/or for the pigtails. Still further embodiments of the present invention may provide additional and/or alternative fiber optic components in the interior cavity of the housing of the LCP.

Turning now to the LCP 70 of FIGS. 4A and 4B, the splitter end 72 does include fiber optic splice tray assembly 74 and fiber optic routing guides 76 within the casing 78. The splitter end 72 also includes a plurality of splitters 80 and the plurality of receptacles 82 similar to the embodiments of FIGS. 1A-2C. Therefore, the LCP 70 of FIGS. 4A and 4B includes some of the functionality of the LCP 50 of FIGS. 3A-3C, while also providing the ease of installation of the LCP 10 of FIGS. 1A-2C. Still further advantages can be realized by combining the various fiber optic hardware components and techniques of the embodiments of FIGS. 1A-4B and further embodiments of the present invention.

In addition to providing convenient installation of the LCP within and/or near the MDU, the LCPs of certain embodiments of the present invention also provide improved density of connections, which significantly reduces the cost of the hardware and enables technicians to more easily install the LCP and associated fiber optic hardware and to increase the possible places the LCP and associated fiber optic hardware may be installed and/or mounted. Whereas prior art LCPs generally define a width of 13.5 inches, a height of 15.5 inches, and a depth of 5.5 inches along the

exterior of the LCP while providing only 48 receptacles for subscriber optical fibers, the LCPs of the illustrated embodiments of the present invention generally define a width of 9.8 inches, a height of 12.6 inches, and a depth of 3.8 inches while providing 288 receptacles for subscriber optical fibers. Therefore, the prior art LCPs define a density of receptacles per unit of volume of the housing of about 0.042 receptacles/in<sup>3</sup>, and the LCPs of the illustrated embodiments define a density of receptacles per unit of volume of the housing of about 0.614 receptacles/in<sup>3</sup>, which is a significant improvement in density that can be used to provide smaller LCPs and/or provide additional optical connectivity with the LCPs of the present invention. Various embodiments of the present invention preferably provide a density of receptacles per unit of volume of the housing from about 0.10 receptacles/in<sup>3</sup> to about 4.0 receptacles/in<sup>3</sup>, more preferably a density of receptacles per unit of volume of the housing from about 0.25 receptacles/in<sup>3</sup> to about 2.0 receptacles/in<sup>3</sup>, and still more preferably a density of receptacles per unit of volume of the housing from about 0.50 receptacles/in<sup>3</sup> to about 1.0 receptacles/in<sup>3</sup>.

The LCPs of FIGS. 1A-4B include receptacles that are adapted to receive connectors of subscriber optical fibers that comprise 5 mm optical connectors, which may be arranged in relatively dense patterns as a distance of only 5 mm is required between centers in both lateral and longitudinal directions ("5 mm optical connectors"). Still further embodiments of the present invention include receptacles adapted to receive MU connectors that may also be arranged in relatively dense patterns, but require 4.5 mm to 5 mm between centers in either a lateral or longitudinal direction and about 10 mm in the opposite direction; thereby requiring slightly large volume than the 5 mm optical connectors. Additional embodiments of the present invention include receptacles adapted to receive SC, LC, ST, FC, MT-RJ, MTP, and other fiber optic connectors and adapted to receive single-mode or multimode fibers in simplex, duplex, or multi-fiber arrangements.

FIGS. 5A-5D illustrate yet another LCP 90 of the present invention, wherein the LCP includes a plurality of multi-fiber receptacles 92 adapted to received multi-fiber connectors (not shown) of the subscriber optical fibers. The housing 94 of the LCP 90 defines an interior cavity 96 into which a plurality of splitter modules 98 may be received. Rather than providing a cable assembly as in the embodiments discussed above, the LCP 90 is adapted to house a plurality of splitter modules 98. The splitter modules 98 of the illustrated embodiments includes a single input opening 100 and a plurality of output openings 102 to which optical fibers may be routed and connected via multi-fiber connectors (not shown). The optical fibers pass through the openings 104 and 106 similar to the embodiments described above; however, it would be possible to change the routing if desired by the technician. The splitter modules 98 include a splitter (not shown) that splits the optical signal received through the input opening 100 to the plurality of receptacles of the output openings. The splitter modules 98 are installed by fastening them to brackets 108 provided in the interior cavity 96 of the housing 94; however, further embodiments may install the splitter modules in alternative fashions, such as by providing a splitter end of a cable assembly wherein the splitter end is adapted to receive at least one splitter module within the splitter end, to describe one non-limiting example. The LCP 90 of FIGS. 5A-5D includes an access cover 110 to limit access to the splitter modules to technicians. The splitter modules of certain embodiments of the

present invention include the splitter modules of FIGS. 13A-13D described in more detail below.

FIGS. 6 and 7 illustrate the LCPs (not to scale) of certain embodiments of the present invention installed in an MDU 120. The MDU 120 of FIGS. 6 and 7 comprises an apartment building having nine dwelling units 122 for illustrative purposes only. The LCP 124 is positioned on the ground floor or basement in the illustrated embodiment; however, the LCP of further embodiments is positioned at any location relative to the MDU. The LCP 124 includes a cable assembly 126 that is optically connected to a distribution cable 128 via the cable assembly optical fiber(s) 130 as described above. As also described above, the subscriber optical fibers 132 that are connected to the receptacles of the LCP 124 exit the LCP and extend throughout the MDU. The subscriber optical fibers 132 of FIG. 6 extend directly to each dwelling unit and terminate at a subscriber termination point 134, such as an adapter in a wall outlet, an adapter in a floor panel, an adapter behind a ceiling tile, or the like such that the subscriber can optically connect directly (or indirectly in some situations) to the subscriber optical fiber 132. Although the optical fibers 130 and 132 include arrows pointing in the direction of the subscriber termination points 134, it should be appreciated that optical signals may be passed in either direction as required for the particular application; the arrows are merely provided for illustrative purposes.

FIG. 7 is also provided to illustrate embodiments in which the subscriber optical fiber 132 is optically connected to a fiber distribution terminal ("FDT") 136 (not to scale) rather than the subscriber termination point 134. FDTs are provided to simplify the routing and installation of the optical fibers between the LCP 124 and the subscriber termination points 134 by allowing the subscriber optical fibers 132 to be grouped between the LCP and FDT and then separated at the FDT. More specifically, the subscriber optical fibers 132 of FIG. 7 comprise multi-fiber cables comprising a plurality of optical fibers, such as ribbon fiber to provide one non-limiting example. As explained more fully below, the subscriber optical fiber 132 is separated into multiple subscriber drop optical fibers 138 that are routed from the FDT 136 to the subscriber termination points 134. As shown in FIG. 7, each floor of the MDU 120 includes a FDT, such that each of the three subscriber optical fibers 132 is divided into three subscriber drop optical fibers 136. Accordingly, there are fewer optical fibers and/or cables extending between the floors of the MDU thus simplifying routing of optical fibers through the MDU. Although floors of an MDU are described in the illustrated embodiments, it should be appreciated that FDTs may be used to facilitate optical fiber routing to any layout of areas within an MDU.

Turning now to the FDTs of FIGS. 8A-11C, various FDTs are included in the present invention. The FDT 140 of FIGS. 8A-8D comprises a generally rectangular housing 142 that defines a top wall 144, a bottom wall 146, and a sidewall 148 extending therebetween. The FDT 140 includes an input opening 150 defined in the sidewall 148, and the input opening is adapted to receive at least one input optical fiber. For the FDT 140 of FIGS. 8A-8D, the input opening 150 receives a single subscriber optical cable 152 that comprises twelve subscriber optical fibers. The FDT 140 defines a direct cable input as compared to the multi-fiber connector input of the embodiment of FIGS. 9A-9C described below. The FDT 140 of FIGS. 8A-8D also includes an output opening 154 defined in the sidewall 148. The output opening 154 comprises a plurality of fiber optic output receptacles 156 adapted to receive fiber optic connectors, such as from

a subscriber drop optical fiber (not shown), to optically connect the fiber optic connector to a respective one of the input optical fibers. The FDTs of further embodiments of the present invention are adapted to receive any number of input optical fibers and provide any number of fiber optic output receptacles. The FDT 140 of FIG. 8B includes a removable portion 158 adapted to selectively cover the fiber optic output receptacles when one or more fiber optic connectors are received in the fiber optic output receptacles to generally protect the connectors from unintentional disconnection, as well as other undesirable problems that may be created by unintentional contact of foreign objects with the connectors. The removable portion 158 of FIG. 8B may be easily connected and disconnected by a technician using clips, fasteners, and the like when the technician accesses the output opening 154 and the fiber optic output receptacles 156. The FDT 140 also includes one or more mounting flanges 159 to provide easy installation of the FDT within the MDU.

The FDT 140 of FIGS. 8A-8D provides a significant advantage over prior art FDTs in that the FDT 140 provides easy installation and connectivity, as well as requiring significantly less volume than prior art FDTs. Prior art FDTs typically use a housing similar to the LCP housings described above or an even larger cabinet or the like. Therefore, prior art FDTs provide for only about a density of receptacles per unit of volume of the housing of about 0.042 receptacles/in<sup>3</sup>. However, the FDT 140 of FIGS. 8A-8D generally defines (not including the mounting flanges or removable portion area) a width of 1.38 inches, a height of 1.35 inches, and a depth of 0.55 inches while providing 12 receptacles for subscriber optical fibers. Therefore, the FDT 140 provides a density of receptacles per unit of volume of the housing of about 11.7 receptacles/in<sup>3</sup>, which is a significant improvement in density over the prior art. Various embodiments of the present invention preferably provide direct cable input FDTs having a density of receptacles per unit of volume of the housing from about 1.0 receptacles/in<sup>3</sup> to about 40 receptacles/in<sup>3</sup>, more preferably a density of receptacles per unit of volume of the housing from about 5.0 receptacles/in<sup>3</sup> to about 20 receptacles/in<sup>3</sup>, and still more preferably a density of receptacles per unit of volume of the housing from about 10 receptacles/in<sup>3</sup> to 0.3 about 15 receptacles/in<sup>3</sup>.

Referring now to the FDTs of FIGS. 9A-9C, a multi-fiber connector input FDT 160 is provided. The FDT 160 of FIGS. 9A-9C comprises a generally rectangular housing 162 that defines a top wall 164, a bottom wall 166, and a sidewall 168 extending therebetween. The FDT 160 includes an input opening 170 defined in the sidewall 168, and the input opening is adapted to receive at least one input optical fiber. For the FDT 160 of FIGS. 9A-9C, the input opening 170 provides a multi-fiber receptacle 172 to which a multi-fiber connector may be selectively received. The multi-fiber connector of the subscriber optical cable (not shown) comprises twelve subscriber optical fibers. The FDT 160 of FIGS. 9A-9C also includes an output opening 174 defined in the sidewall 168. The output opening 174 comprises a plurality of fiber optic output receptacles 156 adapted to receive fiber optic connectors, such as from a subscriber drop optical fiber (not shown), to optically connect the fiber optic connector to a respective one of the input optical fibers. The FDTs of further embodiments of the present invention are adapted to receive any number of input optical fibers and to provide any number of fiber optic output receptacles.

Similar to the direct cable input FDT 140 of FIGS. 8A-8D, the multi-fiber connector input FDT 160 of FIGS.



9A-9C provides a significant advantage over prior art FDTs in that the FDT 140 provides easy installation and connectivity, as well as requiring significantly less volume than prior art FDTs. As mentioned above, prior art FDTs typically provide a density of receptacles per unit of volume of the housing of about 0.042 receptacles/in<sup>3</sup>. However, the FDT 160 of FIGS. 9A-9C generally defines (not including the mounting flanges or removable portion area) a width of 2.09 inches, a height of 1.35 inches, and a depth of 0.55 inches while providing 12 receptacles for subscriber optical fibers. Therefore, the FDT 160 provides a density of receptacles per unit of volume of the housing of about 7.73 receptacles/in<sup>3</sup>, which is a significant improvement in density over the prior art. Various embodiments of the present invention preferably provide multi-fiber connector input FDTs having a density of receptacles per unit of volume of the housing from about 1.0 receptacles/in<sup>3</sup> to about 40 receptacles/in<sup>3</sup>, more preferably a density of receptacles per unit of volume of the housing from about 5.0 receptacles/in<sup>3</sup> to about 20 receptacles/in<sup>3</sup>, and still more preferably a density of receptacles per unit of volume of the housing from about 6.0 receptacles/in<sup>3</sup> to about 12 receptacles/in<sup>3</sup>.

Referring now to the multi-fiber connector input FDTs of FIGS. 10A-11C, each FDT 180 and 200 are similar to the multi-fiber connector input FDT 160 of FIGS. 9A-9C but provide the input openings 182 and 202 at slightly different positions and provide eight MU fiber optic output receptacles 184 and 204 of the output openings 186 and 206 as opposed to the twelve 5 mm fiber optic output receptacles 156 (for receiving 5 mm optical connectors). The FDTs 182 and 202 also do not include mounting flanges and/or the removable portion; however, further embodiments of the present invention include FDTs that include any combination of the features described herein. The FDT 180 of FIGS. 10A-10C includes the input opening 182 in the sidewall 188 such that the input opening defines an input axis 190 generally orthogonal to the input opening 182 and the output opening 186 defines an output axis 192 generally orthogonal to the output opening, such that the input axis and the output axis are generally orthogonal to one another. The input axis 190 and the output axis 192 of the openings of the FDT 160 of FIGS. 9A-9C are also orthogonal to one another; however, the input opening of the FDT 180 of FIGS. 10A-10C has been recessed a significant amount to protect the multi-fiber connector 194 of the subscriber optical cable and to further reduce the amount of area required by the FDT and its related connectors. Similarly, the FDT 200 of FIGS. 11A-11C defines an input axis 210 and an output axis 212 that are generally parallel to one another. Therefore, the FDTs of various embodiments of the present invention provide numerous options when selecting the proper FDT to be used in a particular location, with or without particular connectors, with a particular orientation, and the like.

FIGS. 12A-14D illustrate fiber optic hardware components associated with the LCPs of various embodiments of the present invention. The fiber optic hardware components are illustrated to scale relative to similar prior art components to illustrate the differences in sizes and/or orientations achievable using microstructured optical fiber of the present invention, as described more fully below. Turning now to the fiber optic splice tray assembly 220 of FIGS. 12A-12C, the fiber optic splice tray assembly comprises a frame 224 defining a base 226 and a plurality of sidewalls 228 joined to the base, wherein a volume of the splice tray assembly is defined by a length of the base, a width of the base, and a height of the sidewalls. The splice tray assembly also includes a splice tray 230 comprising a plurality of splice

holders 232 joined to the splice tray. The splice holders 232 are adapted to selectively receive a plurality of splices 234 of optical fibers 236. The splice holders 234 are generally angled relative to the sidewalls 228 of the frame 224. At least a portion of the sidewalls 228 defines slack storage generally around the splice tray 230, wherein the slack storage provides for a sufficient amount of slack of the optical fibers 236 associated with the splice generally sufficient for a technician to optically connect the optical fibers with the splice 234. As shown best in FIG. 10B, the splice tray assembly 220 provides slack storage along only two sidewalls 228 of the frame 224.

Based in part upon the use of the microstructured optical fiber described below, the splice tray assembly 220 is adapted to provide a significant improvement in the density of splices per unit of volume of the splice tray assembly, thus reducing the size, number, and/or costs of splice tray assemblies required for a particular application. Whereas prior art splice tray assemblies 236 generally define along the exterior a width of 3.94 inches, a length of 9.34 inches, and a depth of 0.4 inches while providing 24 splice holders, the splice tray assembly of the illustrated embodiment of the present invention generally defines along the exterior a width of 2.44 inches, a length of 6.34 inches, and a depth of 0.4 inches while providing 24 splice holders. Therefore, the prior art splice tray assemblies define a density of splice holders per unit of volume of the splice tray assembly of about 1.63 single splices/in<sup>3</sup> and about 3.26 mass fusion splices/in<sup>3</sup>, and the splice tray assembly of the illustrated embodiment defines a density of splice holders per unit of volume of the splice tray assembly of about 3.87 single splices/in<sup>3</sup> and about 7.76 mass fusion splices/in<sup>3</sup>. Various embodiments of the present invention preferably provide a density of splice holders per unit of volume of the splice tray assembly of at least 3 single splices/in<sup>3</sup> or at least 6 mass fusion splices/in<sup>3</sup>, more preferably a density of splice holders per unit of volume of the splice tray assembly of at least 5 single splices/in<sup>3</sup> or at least 10 mass fusion splices/in<sup>3</sup>, and still more preferably a density of splice holders per unit of volume of the splice tray assembly of at least 8 single splices/in<sup>3</sup> or at least 16 mass fusion splices/in<sup>3</sup>.

Turning now to the fiber optic splitter module 240 of FIGS. 13A-13C, the splitter module optically connects at least one input optical fiber 242 and a plurality of output optical fibers 244. The splitter module comprises a housing 246 having at least one opening 248 therethrough, wherein the opening defines an opening axis 250 generally orthogonal to the opening. The splitter module also includes a splitter 252 within the housing 246, wherein the input optical fiber 242 is optically connected to the plurality of output optical fibers 244 by the splitter 252. The splitter 252 defines a splitter axis 254 generally aligned with the input optical fiber 242 and the plurality of output optical fibers 244 proximate the splitter. In the splitter module 240 of FIGS. 13A-13C, the splitter axis 254 is generally orthogonal to the opening axis 250. It should be noted that the splitter module 240 does not include a slack loop for either the input optical fiber 242 or the output optical fiber 244, based in part upon the performance of the microstructured optical fiber used in some embodiments of the present invention.

Also based in part upon the use of the microstructured optical fiber described below, the splitter module 240 is adapted to provide a significant improvement in the density of output optical fiber splits per unit of volume of the splitter module housing, thus reducing the size, number, and/or costs of splitter modules required for a particular application. Whereas prior art splitter module 256 generally defines

along the exterior a width of 3.07 inches, a length of 4.85 inches, and a depth of 0.92 inches while providing 32 output fiber splits, the splice tray assembly of the illustrated embodiment of the present invention generally defines along the exterior a width of 3.47 inches, a length of 1.83 inches, and a depth of 0.83 inches while providing 32 output fiber splits. Therefore, the prior art splice tray assemblies define a density of output optical fiber splits per unit of volume of the splitter module housing of about 2.34 splits/in<sup>3</sup>, and the splice tray assembly of the illustrated embodiment density of output optical fiber splits per unit of volume of the splitter module housing of about 6.07 splits/in<sup>3</sup>. Various embodiments of the present invention preferably provide a density of output optical fiber splits per unit of volume of the splitter module housing of about 4 splits/in<sup>3</sup> to about 10 splits/in<sup>3</sup>, more preferably a density of output optical fiber splits per unit of volume of the splitter module housing of about 5 splits/in<sup>3</sup> to about 8 splits/in<sup>3</sup>, and still more preferably a density of output optical fiber splits per unit of volume of the splitter module housing of about 6 splits/in<sup>3</sup> to about 7 splits/in<sup>3</sup>. It should be appreciated that the numbers given above are for 1×32 splitters and that additional splitter modules of the present invention generally define the same volume while including alternative numbers of splits, such that the amounts given above should be adjusted accordingly based upon the splitter ratio of the actual splitter(s) used in the splitter module.

Turning now to the fiber optic routing guide **260** of FIGS. **14A-14E**, the fiber optic routing guide is adapted for use in an enclosure of a fiber optic network, such as the housing (and/or splitter end of the cable assembly) of an LCP as described above, to provide one non-limiting example. The routing guide **260** is adapted to store slack of an optical fiber **262**, such as an optical fiber having an outer diameter of 900 μm to provide one non-limiting example. The routing guide **260** comprises a housing **264** defining an outer surface **266** generally located between a top surface **268** and a bottom surface **270**. The routing guide **260** also includes a core portion **272** defining a fiber routing surface **274** along the perimeter of the core portion between the top surface **268** and the bottom surface **270**. The core portion **272** is generally centered in the housing **264**, and the fiber routing surface is adapted to receive the routed optical fiber **262**. The routing guide **260** further includes an outer wall **276** joined to the core portion **272**. The outer wall **276** defines the outer surface **266** of the housing **264** and defines an inner surface **278** opposite the outer surface and facing the fiber routing surface **274** of the core portion **272**. For the routing guide **260** of FIGS. **14A-14C**, the fiber routing surface **278** generally defines a plurality of curved surfaces having a common center, the outer surface **266** generally defines a plurality of curved surfaces having a common center, and the centers for both the fiber routing surface and the outer surface correspond (same center). Tab portions **280** extending radially from the fiber routing surface **274** and the inner surface **278**. The volume of the routing guide **260** is defined along the outer surface **266** between the top surface **268** and the bottom surface **270**.

Based in part upon the use of the microstructured optical fiber described below, the routing guide **260** of FIGS. **14A-14C** is adapted to provide a significant improvement in the amount of length of optical fiber stored by the routing guide per unit of volume of the housing, thus reducing the size, number, and/or costs of routing guides required for a particular application. Whereas prior art routing guides **282** generally define an outer diameter along the outer surface of 2.50 inches and a height of 0.56 inches while being able to

store 323 inches of 900 μm optical fiber, the routing guide of the illustrated embodiment of the present invention generally defines an outer diameter along the outer surface of 1.05 inches and a height of 0.56 inches while being able to store 290 inches of 900 μm optical fiber. Therefore, the prior art routing guides is adapted to store an amount of length of optical fiber per unit of volume of the housing of about 6.12 inches of 900 μm diameter optical fiber/in<sup>3</sup>, and the routing guide of the illustrated embodiment is adapted to store an amount of length of optical fiber per unit of volume of the housing of about 13.1 inches of 900 μm diameter optical fiber/in<sup>3</sup>. Various embodiments of the present invention preferably store an amount of length of optical fiber per unit of volume of the housing of about 10 inches of 900 μm diameter optical fiber/in<sup>3</sup> to about 20 inches of 900 μm diameter optical fiber/in<sup>3</sup>, more preferably store an amount of length of optical fiber per unit of volume of the housing of about 11 inches of 900 μm diameter optical fiber/in<sup>3</sup> to about 18 inches of 900 μm diameter optical fiber/in<sup>3</sup>, and still more preferably store an amount of length of optical fiber per unit of volume of the housing of about 13 inches of 900 μm diameter optical fiber/in<sup>3</sup> to about 15 inches of 900 μm diameter optical fiber/in<sup>3</sup>. Still further routing guides of further embodiments of the present invention include differently shaped and/or sized routing guides adapted to hold alternative lengths of optical fibers having alternative diameters.

Various embodiments of the present invention are adapted to include bend performance optical fibers. One example of bend performance optical fiber is a microstructured optical fiber having a core region and a cladding region surrounding the core region, the cladding region comprising an annular hole-containing region comprised of non-periodically disposed holes such that the optical fiber is capable of single mode transmission at one or more wavelengths in one or more operating wavelength ranges. The core region and cladding region provide improved bend resistance, and single mode operation at wavelengths preferably greater than or equal to 1500 nm, in some embodiments also greater than about 1310 nm, in other embodiments also greater than 1260 nm. The optical fibers provide a mode field at a wavelength of 1310 nm preferably greater than 8.0 microns, more preferably between about 8.0 and 10.0 microns. In preferred embodiments, optical fiber disclosed herein is thus single-mode transmission optical fiber.

In some embodiments of the present invention, the microstructured optical fibers disclosed herein comprises a core region disposed about a longitudinal centerline and a cladding region surrounding the core region, the cladding region comprising an annular hole-containing region comprised of non-periodically disposed holes, wherein the annular hole-containing region has a maximum radial width of less than 12 microns, the annular hole-containing region has a regional void area percent of less than about 30 percent, and the non-periodically disposed holes have a mean diameter of less than 1550 nm.

By “non-periodically disposed” or “non-periodic distribution”, it is meant that when one takes a cross-section (such as a cross-section perpendicular to the longitudinal axis) of the optical fiber, the non-periodically disposed holes are randomly or non-periodically distributed across a portion of the fiber. Similar cross sections taken at different points along the length of the fiber will reveal different cross-sectional hole patterns, i.e., various cross-sections will have different hole patterns, wherein the distributions of holes and sizes of holes do not match. That is, the holes are non-periodic, i.e., they are not periodically disposed within the

fiber structure. These holes are stretched (elongated) along the length (i.e. in a direction generally parallel to the longitudinal axis) of the optical fiber, but do not extend the entire length of the entire fiber for typical lengths of transmission fiber.

For a variety of applications, it is desirable for the holes to be formed such that greater than about 95% of and preferably all of the holes exhibit a mean hole size in the cladding for the optical fiber which is less than 1550 nm, more preferably less than 775 nm, most preferably less than 390 nm. Likewise, it is preferable that the maximum diameter of the holes in the fiber be less than 7000 nm, more preferably less than 2000 nm, and even more preferably less than 1550 nm, and most preferably less than 775 nm. In some embodiments, the fibers disclosed herein have fewer than 5000 holes, in some embodiments also fewer than 1000 holes, and in other embodiments the total number of holes is fewer than 500 holes in a given optical fiber perpendicular cross-section. Of course, the most preferred fibers will exhibit combinations of these characteristics. Thus, for example, one particularly preferred embodiment of optical fiber would exhibit fewer than 200 holes in the optical fiber, the holes having a maximum diameter less than 1550 nm and a mean diameter less than 775 nm, although useful and bend resistant optical fibers can be achieved using larger and greater numbers of holes. The hole number, mean diameter, max diameter, and total void area percent of holes can all be calculated with the help of a scanning electron microscope at a magnification of about 800 $\times$  and image analysis software, such as ImagePro, which is available from Media Cybernetics, Inc. of Silver Spring, Md., USA.

The optical fibers disclosed herein may or may not include germania or fluorine to also adjust the refractive index of the core and or cladding of the optical fiber, but these dopants can also be avoided in the intermediate annular region and instead, the holes (in combination with any gas or gases that may be disposed within the holes) can be used to adjust the manner in which light is guided down the core of the fiber. The hole-containing region may consist of undoped (pure) silica, thereby completely avoiding the use of any dopants in the hole-containing region, to achieve a decreased refractive index, or the hole-containing region may comprise doped silica, e.g. fluorine-doped silica having a plurality of holes.

In one set of embodiments, the core region includes doped silica to provide a positive refractive index relative to pure silica, e.g. germania doped silica. The core region is preferably hole-free. In some embodiments, the core region comprises a single core segment having a positive maximum refractive index relative to pure silica  $\Delta_1$  in %, and the single core segment extends from the centerline to a radius R1. In one set of embodiments,  $0.30\% < \Delta_1 < 0.40\%$ , and  $3.0 \mu\text{m} < R1 < 5.0 \mu\text{m}$ . In some embodiments, the single core segment has a refractive index profile with an alpha shape, where alpha is 6 or more, and in some embodiments alpha is 8 or more. In some embodiments, the inner annular hole-free region extends from the core region to a radius R2, wherein the inner annular hole-free region has a radial width W12, equal to  $R2 - R1$ , and W12 is greater than 1  $\mu\text{m}$ . Radius R2 is preferably greater than 5  $\mu\text{m}$ , more preferably greater than 6  $\mu\text{m}$ . The intermediate annular hole-containing region extends radially outward from R2 to radius R3 and has a radial width W23, equal to  $R3 - R2$ . The outer annular region 186 extends radially outward from R3 to radius R4. Radius R4 is the outermost radius of the silica portion of the optical fiber. One or more coatings may be applied to the external surface of the silica portion of the optical fiber, starting at

R4, the outermost diameter or outermost periphery of the glass part of the fiber. The core region and the cladding region are preferably comprised of silica. The core region is preferably silica doped with one or more dopants. Preferably, the core region is hole-free. The hole-containing region has an inner radius R2 which is not more than 20  $\mu\text{m}$ . In some embodiments, R2 is not less than 10  $\mu\text{m}$  and not greater than 20  $\mu\text{m}$ . In other embodiments, R2 is not less than 10  $\mu\text{m}$  and not greater than 18  $\mu\text{m}$ . In other embodiments, R2 is not less than 10  $\mu\text{m}$  and not greater than 14  $\mu\text{m}$ . Again, while not being limited to any particular width, the hole-containing region has a radial width W23 which is not less than 0.5  $\mu\text{m}$ . In some embodiments, W23 is not less than 0.5  $\mu\text{m}$  and not greater than 20  $\mu\text{m}$ . In other embodiments, W23 is not less than 2  $\mu\text{m}$  and not greater than 12  $\mu\text{m}$ . In other embodiments, W23 is not less than 2  $\mu\text{m}$  and not greater than 10  $\mu\text{m}$ .

Such fiber can be made to exhibit a fiber cutoff of less than 1400 nm, more preferably less than 1310 nm, a 20 mm macrobend induced loss at 1550 nm of less than 1 dB/turn, preferably less than 0.5 dB/turn, even more preferably less than 0.1 dB/turn, still more preferably less than 0.05 dB/turn, yet more preferably less than 0.03 dB/turn, and even still more preferably less than 0.02 dB/turn, a 12 mm macrobend induced loss at 1550 nm of less than 5 dB/turn, preferably less than 1 dB/turn, more preferably less than 0.5 dB/turn, even more preferably less than 0.2 dB/turn, still more preferably less than 0.01 dB/turn, still even more preferably less than 0.05 dB/turn, and a 8 mm macrobend induced loss at 1550 nm of less than 5 dB/turn, preferably less than 1 dB/turn, more preferably less than 0.5 dB/turn, and even more preferably less than 0.2 dB/turn, and still even more preferably less than 0.1 dB/turn.

The fiber of some embodiments of the present invention comprises a core region that is surrounded by a cladding region that comprises randomly disposed voids which are contained within an annular region spaced from the core and positioned to be effective to guide light along the core region. Other optical fibers and microstructured fibers may be used in the present invention. Additional features of the microstructured optical fibers of additional embodiments of the present invention are described more fully in pending U.S. patent application Ser. No. 11/583,098 filed Oct. 18, 2006, and provisional U.S. patent application Ser. Nos. 60/817,863 filed Jun. 30, 2006; 60/817,721 filed Jun. 30, 2006; 60/841,458 filed Aug. 31, 2006; and 60/841,490 filed Aug. 31, 2006; all of which are assigned to Corning Incorporated and the disclosures of which are incorporated by reference herein.

Many modifications and other embodiments of the invention set forth herein will come to mind to one skilled in the art to which the invention pertains having the benefit of the teachings presented in the foregoing descriptions and the associated drawings. Therefore, it is to be understood that the invention is not to be limited to the specific embodiments disclosed and that modifications and other embodiments are intended to be included within the scope of the appended claims. It is intended that the present invention cover the modifications and variations of this invention provided they come within the scope of the appended claims and their equivalents. Although specific terms are employed herein, they are used in a generic and descriptive sense only and not for purposes of limitation.

The invention claimed is:

[1. A fiber optic splitter module for optically connecting at least one input optical fiber and a plurality of output optical fibers, the splitter module comprising:

19

a housing having at least one opening therethrough, wherein the opening defines an opening axis generally orthogonal to the opening; and  
 a splitter within the housing, wherein the input optical fiber is optically connected to the plurality of output optical fibers by the splitter, wherein the splitter defines a splitter axis generally aligned with the input optical fiber and the plurality of output optical fibers;  
 wherein the splitter axis is generally orthogonal to the opening axis; and  
 wherein the splitter module defines a density of output optical fiber splits per unit of volume of the housing of at least 5 splits/in<sup>3</sup>.]

[2. A splitter module according to claim 1, wherein the input optical fiber and the plurality of output optical fibers are routed within the housing generally without a slack loop.]

[3. A fiber optic splitter module for optically connecting at least one input optical fiber and a plurality of output optical fibers, the splitter module comprising:

a housing having at least one opening therethrough, wherein the opening defines an opening axis generally orthogonal to the opening; and  
 a splitter within the housing, wherein the input optical fiber is optically connected to the plurality of output optical fibers by the splitter, wherein the splitter defines a splitter axis generally aligned with the input optical fiber and the plurality of output optical fibers;  
 wherein the splitter axis is generally orthogonal to the opening axis; and  
 wherein the splitter module defines a density of output optical fiber splits per unit of volume of the housing from about 4 splits/in<sup>3</sup> to about 10 splits/in<sup>3</sup>.]

[4. A fiber optic splitter module for optically connecting at least one input optical fiber and a plurality of output optical fibers, the splitter module comprising:

a housing having at least one opening therethrough, wherein the opening defines an opening axis generally orthogonal to the opening; and  
 a splitter within the housing, wherein the input optical fiber is optically connected to the plurality of output optical fibers by the splitter, wherein the splitter defines a splitter axis generally aligned with the input optical fiber and the plurality of output optical fibers;  
 wherein the splitter axis is generally orthogonal to the opening axis; and  
 wherein at least one optical fiber of the plurality of output optical fibers comprises a microstructured optical fiber comprising a core region and a cladding region surrounding the core region, the cladding region comprising an annular hole-containing region comprised of non-periodically disposed holes.]

[5. A splitter module according to claim 4, wherein the microstructured fiber has an 8 mm macrobend induced loss at 1550 nm of less than 0.2 dB/turn.]

[6. A splitter module according to claim 1, wherein at least one optical fiber of the plurality of output optical fibers comprises a microstructured optical fiber comprising a core region and a cladding region surrounding the core region, the cladding region comprising an annular hole-containing region comprised of non-periodically disposed holes.]

[7. A splitter module according to claim 6, wherein the microstructured fiber has an 8 mm macrobend induced loss at 1550 nm of less than 0.2 dB/turn.]

20

[8. A splitter module according to claim 3, wherein the input optical fiber and the plurality of output optical fibers are routed within the housing generally without a slack loop.]

[9. A splitter module according to claim 3, wherein at least one optical fiber of the plurality of output optical fibers comprises a microstructured optical fiber comprising a core region and a cladding region surrounding the core region, the cladding region comprising an annular hole-containing region comprised of non-periodically disposed holes.]

[10. A splitter module according to claim 9, wherein the microstructured fiber has an 8 mm macrobend induced loss at 1550 nm of less than 0.2 dB/turn.]

[11. A splitter module according to claim 4, wherein the input optical fiber and the plurality of output optical fibers are routed within the housing generally without a slack loop.]

12. A fiber optic splitter module comprising:  
 a housing having a volume; and

an optical splitter within the housing, wherein the optical splitter is configured to optically connect at least one input optical fiber for carrying an input optical signal and to split the input optical signal into a plurality of output optical signals, each of the plurality of output optical signals carried by a respective output optical fiber, wherein the at least one input optical fiber comprises a bend performance fiber such that with a macrobend of 8 mm to 12 mm the induced loss at a wavelength of 1550 nm is less than 1 dB/turn, wherein the splitter module defines a density of output optical fiber splits per unit of volume of at least 5 splits/in<sup>3</sup>, and wherein at least one of the output optical fibers comprises a connectorized end.

13. The fiber optic splitter module of claim 12, wherein the induced loss is less than 0.5 dB/turn.

14. The fiber optic splitter module of claim 12, wherein the induced loss is less than 0.2 dB/turn.

15. The fiber optic splitter module of claim 12, wherein the induced loss is less than 0.05 dB/turn.

16. The fiber optic splitter module of claim 12, wherein the induced loss is less than 0.01 dB/turn.

17. The fiber optic splitter module of claim 12, wherein the at least one of the output optical fibers is configured to connect at its connectorized end to a subscriber optical fiber.

18. The fiber optic splitter module of claim 12, wherein the optical splitter is configured to split the input optical signal carried by the at least one input optical fiber into 8 output optical signals.

19. The fiber optic splitter module of claim 12, wherein the optical splitter is configured to split the input optical signal carried by the at least one input optical fiber into 16 output optical signals.

20. The fiber optic splitter module of claim 12, wherein the optical splitter is configured to split the input optical signal carried by the at least one input optical fiber into 32 output optical signals.

21. The fiber optic splitter module of claim 12, wherein the optical splitter is configured to split the input optical signal carried by the at least one input optical fiber into 64 output optical signals.

22. A fiber optic splitter module comprising:  
 a housing having a volume;

at least one input optical fiber;

a plurality of output optical fibers; and

an optical splitter within the housing, wherein the optical splitter is configured to receive an input optical signal and to split the input optical signal into a plurality of

21

output optical signals, each of the plurality of output optical signals carried by a respective output optical fiber of the plurality of output optical fibers, wherein the at least one input optical fiber comprises a bend performance fiber such that with a macrobend of 8 mm to 12 mm the induced loss at a wavelength of 1550 nm is less than 1 dB/turn, and wherein the splitter module defines a density of output optical fiber splits per unit of volume of at least 5 splits/in<sup>3</sup>.

23. A fiber optic splitter module comprising:  
 a housing having a volume, wherein the housing defines an opening therethrough;  
 at least one input optical fiber received by the housing through the at least one opening, wherein the input optical fiber is configured to carry an input optical signal;  
 a plurality of output optical fibers received by the housing through the at least one opening, wherein the plurality

22

of output optical fibers are configured to carry a plurality of output optical signals; and  
 an optical splitter within the housing, wherein the optical splitter is configured to receive the input optical signal and to split the input optical signal into the plurality of output optical signals, each of the plurality of output optical signals carried by a respective output optical fiber of the plurality of output optical fibers, wherein the at least one input optical fiber comprises a bend performance fiber such that with a macrobend of 8 mm to 12 mm the induced loss at a wavelength of 1550 nm is less than 1 dB/turn, and wherein the splitter module defines a density of output optical fiber splits per unit of volume of at least 5 splits/in<sup>3</sup>, and wherein at least one of the output optical fibers comprises a connectorized end.

\* \* \* \* \*

UNITED STATES PATENT AND TRADEMARK OFFICE  
**CERTIFICATE OF CORRECTION**

PATENT NO. : RE48,082 E  
APPLICATION NO. : 15/715694  
DATED : July 7, 2020  
INVENTOR(S) : Guy Castonguay et al.

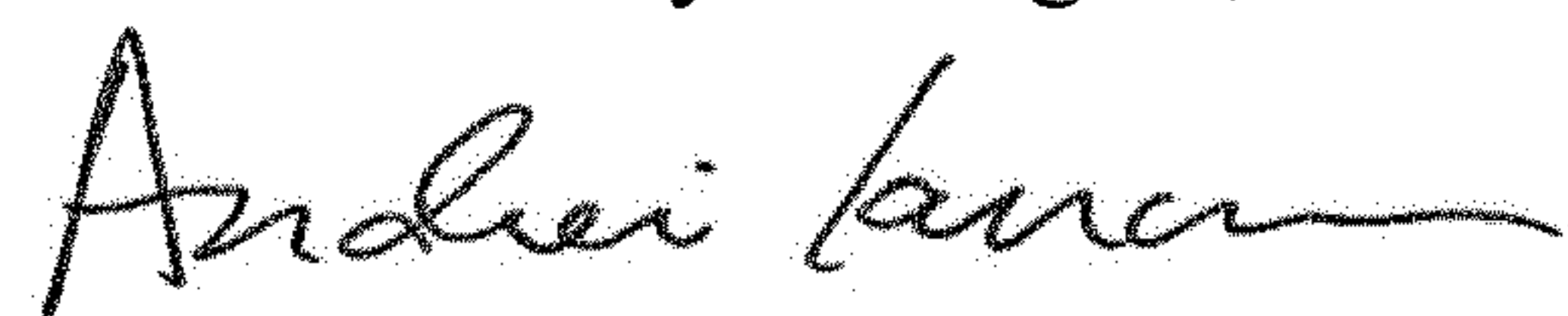
Page 1 of 1

It is certified that error appears in the above-identified patent and that said Letters Patent is hereby corrected as shown below:

In the Claims

At Column 21, Claim 23, Line 12, please delete “an” and insert in its place --at least one--.

Signed and Sealed this  
Eleventh Day of August, 2020



Andrei Iancu  
*Director of the United States Patent and Trademark Office*