



US00RE47958E

(19) **United States**
(12) **Reissued Patent**
Song et al.

(10) **Patent Number:** **US RE47,958 E**
(45) **Date of Reissued Patent:** **Apr. 21, 2020**

(54) **DIGITAL BROADCASTING SYSTEM AND DATA PROCESSING METHOD**

(71) Applicant: **LG ELECTRONICS INC.**, Seoul (KR)

(72) Inventors: **Jae Hyung Song**, Seoul (KR); **In Hwan Choi**, Gwacheon-si (KR); **Kook Yeon Kwak**, Anyang-si (KR); **Byoung Gill Kim**, Seoul (KR); **Won Gyu Song**, Seoul (KR); **Jin Pil Kim**, Seoul (KR); **Jin Woo Kim**, Seoul (KR); **Hyoung Gon Lee**, Seoul (KR); **Jong Moon Kim**, Gwangmyeong-si (KR)

(73) Assignee: **LG ELECTRONICS INC.**, Seoul (KR)

(21) Appl. No.: **15/833,841**

(22) Filed: **Dec. 6, 2017**

Related U.S. Patent Documents

Reissue of:

(64) Patent No.: **8,443,412**
Issued: **May 14, 2013**
Appl. No.: **13/051,743**
Filed: **Mar. 18, 2011**

U.S. Applications:

(63) Continuation of application No. 14/711,531, filed on May 13, 2015, now Pat. No. Re. 46,676, which is an (Continued)

(30) **Foreign Application Priority Data**

Apr. 13, 2007 (KR) 10-2007-0036234

(51) **Int. Cl.**
H04H 60/40 (2008.01)

(52) **U.S. Cl.**
CPC **H04H 60/40** (2013.01)

(58) **Field of Classification Search**
CPC H04H 60/40; H04N 7/08
See application file for complete search history.

(56) **References Cited**

U.S. PATENT DOCUMENTS

5,634,138 A 5/1997 Ananthan
5,649,284 A 7/1997 Yoshinobu
(Continued)

FOREIGN PATENT DOCUMENTS

KR 10-2000-0040481 7/2000
KR 10-2006-0055959 5/2006
(Continued)

OTHER PUBLICATIONS

Intellectual Property Office of India Application Serial No. 6283/CHENP/2009, Office Action dated Dec. 17, 2014, 2 pages.

Primary Examiner — Jalatee Worjloh

(74) *Attorney, Agent, or Firm* — Dentons US LLP

(57) **ABSTRACT**

A digital broadcasting system and a data processing method are disclosed. A time zone identifier is inserted into program table information of a broadcasting signal and the broadcasting signal is transmitted/received. The digital broadcasting system can calculate a local time of a region, in which the digital broadcasting system is located, using the time zone identifier. Accordingly, although the position of the digital broadcasting system is changed, it is possible to process the broadcasting signal related to the local time without an error.

6 Claims, 30 Drawing Sheets

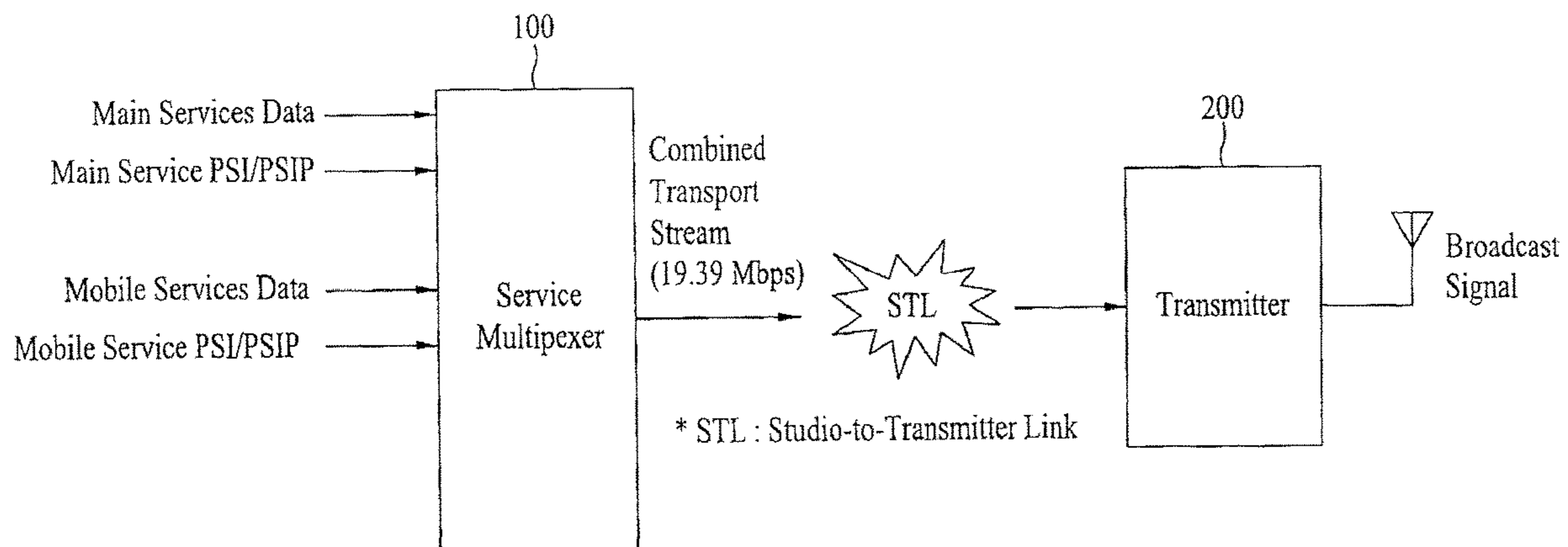

US RE47,958 E

Page 2

Related U.S. Application Data

application for the reissue of Pat. No. 8,443,412, which is a continuation of application No. 12/100,573, filed on Apr. 10, 2008, now Pat. No. 7,934,243.

- (60) Provisional application No. 60/947,984, filed on Jul. 4, 2007, provisional application No. 60/911,812, filed on Apr. 13, 2007.

(56) References Cited

U.S. PATENT DOCUMENTS

5,797,093 A 8/1998 Houde
6,067,457 A 5/2000 Erickson
6,212,659 B1 4/2001 Zehavi
6,229,824 B1 5/2001 Marko
6,243,469 B1 6/2001 Kataoka et al.
6,308,066 B1 10/2001 Ranta et al.
6,309,066 B1* 10/2001 Kan 351/154
6,370,391 B1 4/2002 Lietsalmi
6,378,101 B1* 4/2002 Sinha et al. 714/755
6,553,538 B2 4/2003 Zehavi
6,622,005 B1* 9/2003 Grohn 455/9
6,658,010 B1* 12/2003 Enns et al. 370/401
6,728,230 B2* 4/2004 Odenwalder et al. 370/335
6,735,185 B1 5/2004 Noneman
6,785,288 B1 8/2004 Enns et al.
6,963,588 B1* 11/2005 Lynch H04W 56/0015
370/503
6,977,914 B2 12/2005 Paila et al.

7,565,106 B1* 7/2009 Oh H04B 7/155
370/241
7,593,474 B2 9/2009 Jeong et al.
7,649,829 B2 1/2010 Chen et al.
7,715,461 B2 5/2010 Odenwalder
7,733,817 B2 6/2010 Choi et al.
7,738,391 B2 6/2010 Melpignano et al.
7,751,466 B2 7/2010 Zeng
7,792,103 B2 9/2010 Kim et al.
7,801,243 B2 9/2010 Kim et al.
7,818,519 B2 10/2010 Plunkett
2002/0176324 A1* 11/2002 Ishihara G04G 9/0076
368/47
2002/0194570 A1 12/2002 Birru et al.
2004/0203620 A1* 10/2004 Thome H04M 3/533
455/412.1
2005/0018697 A1 1/2005 Enns et al.
2005/0054345 A1 3/2005 Lee
2005/0168641 A1 8/2005 Seo
2006/0029159 A1 2/2006 Oh
2006/0184965 A1 8/2006 Lee et al.
2007/0071149 A1 3/2007 Li et al.
2008/0089407 A1* 4/2008 Kim H04N 19/70
375/240.01

FOREIGN PATENT DOCUMENTS

KR 10-2006-0068449 6/2006
KR 10-2007-0013168 1/2007
WO 01/05157 1/2001

* cited by examiner

FIG. 1

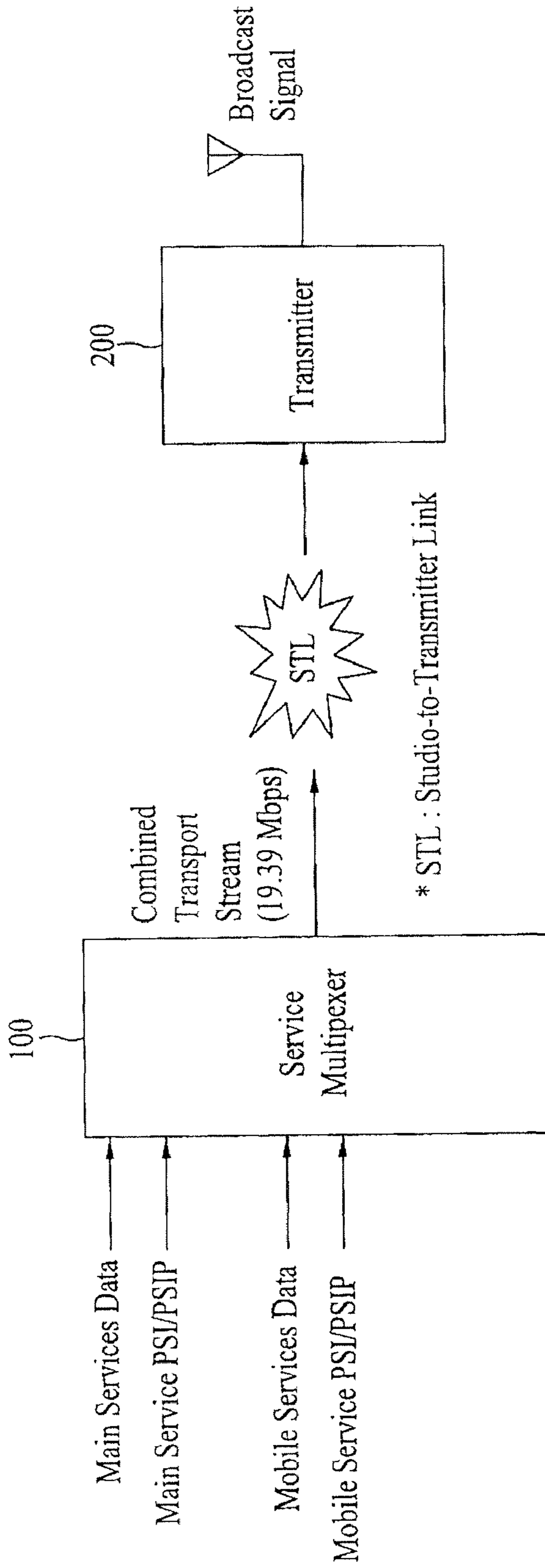

FIG. 2

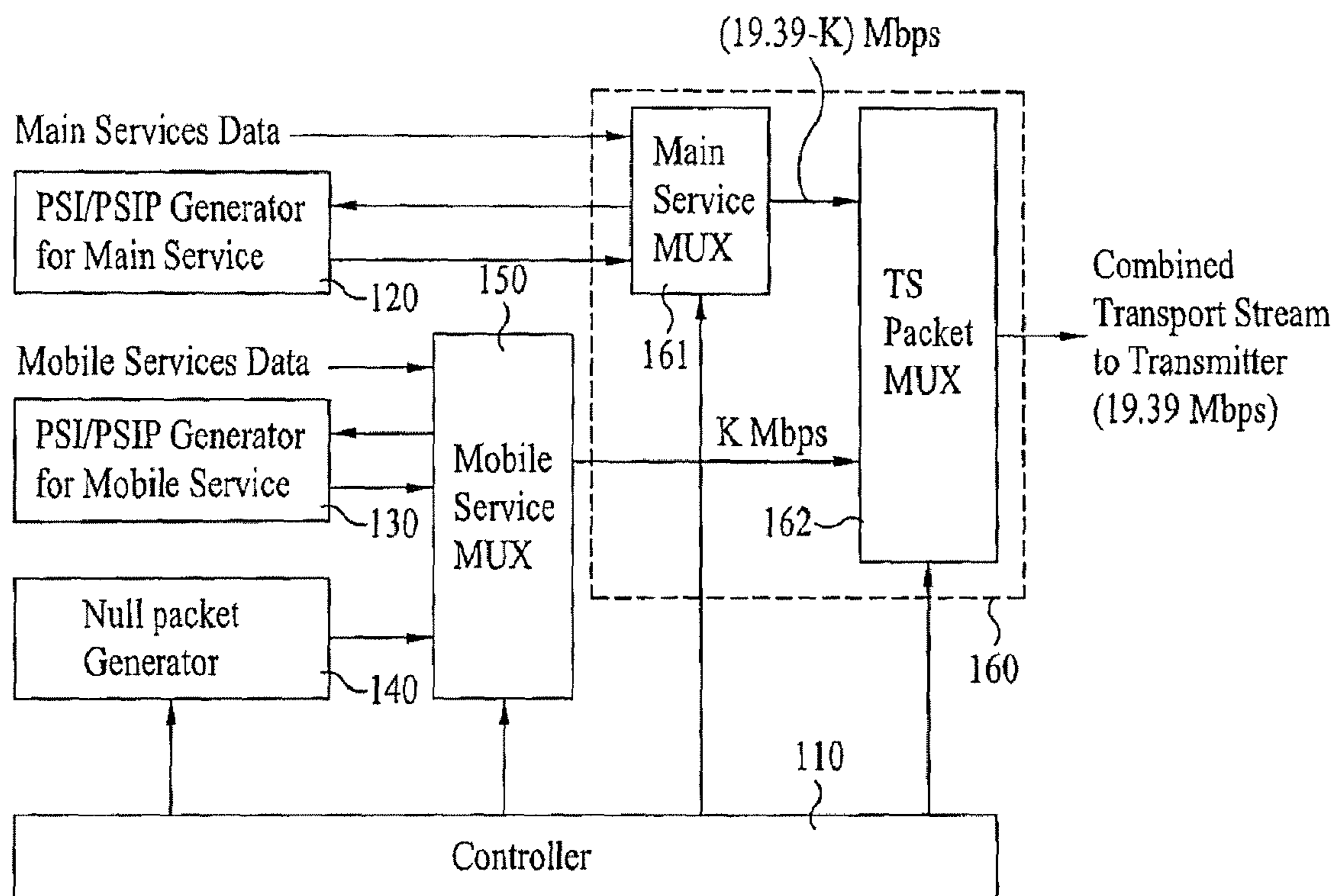

FIG. 3

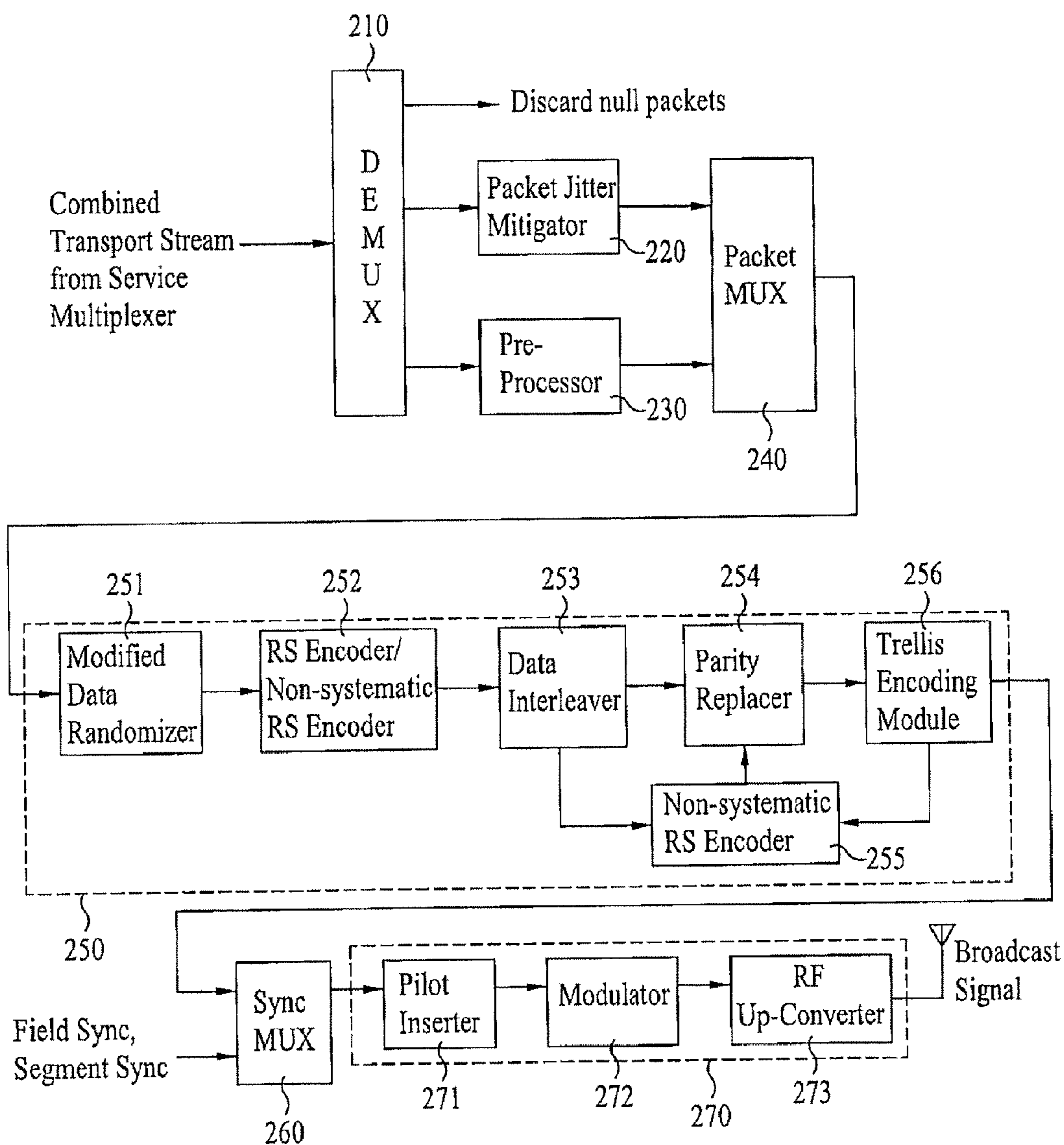

FIG. 4

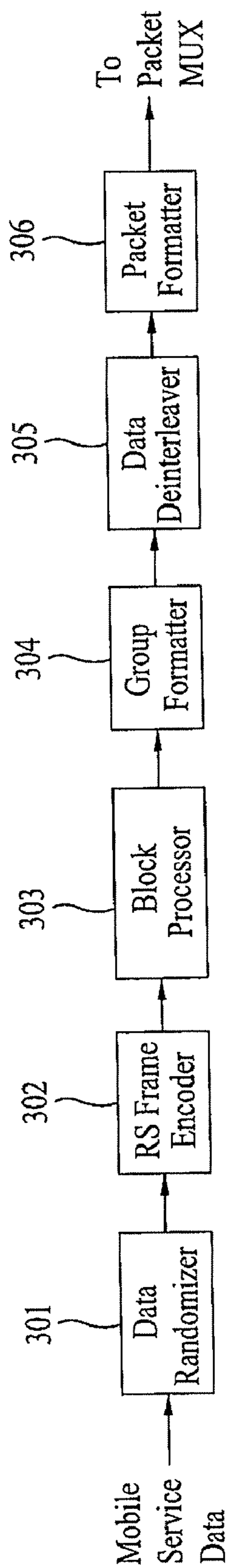

FIG. 5

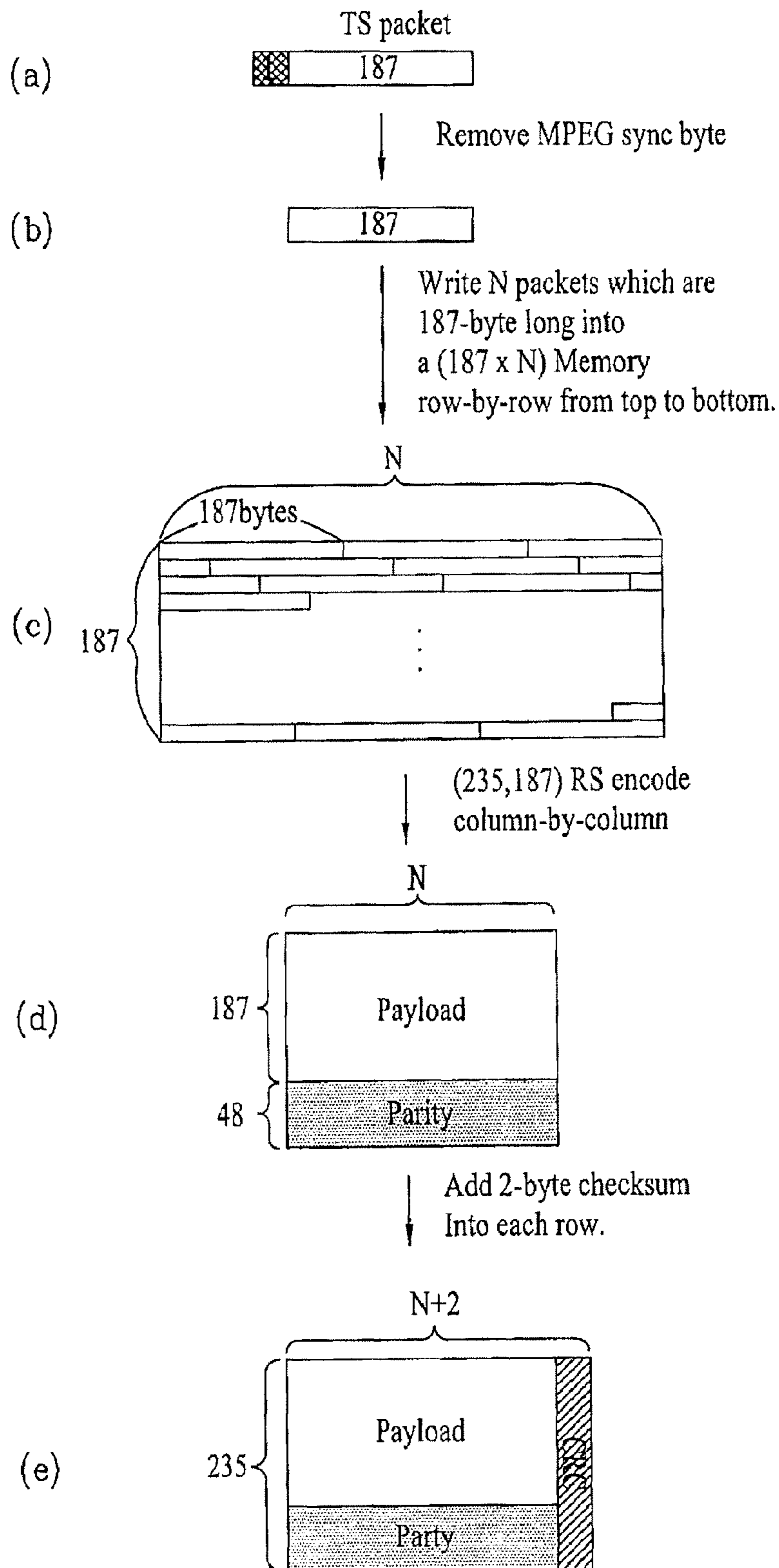

FIG. 6A

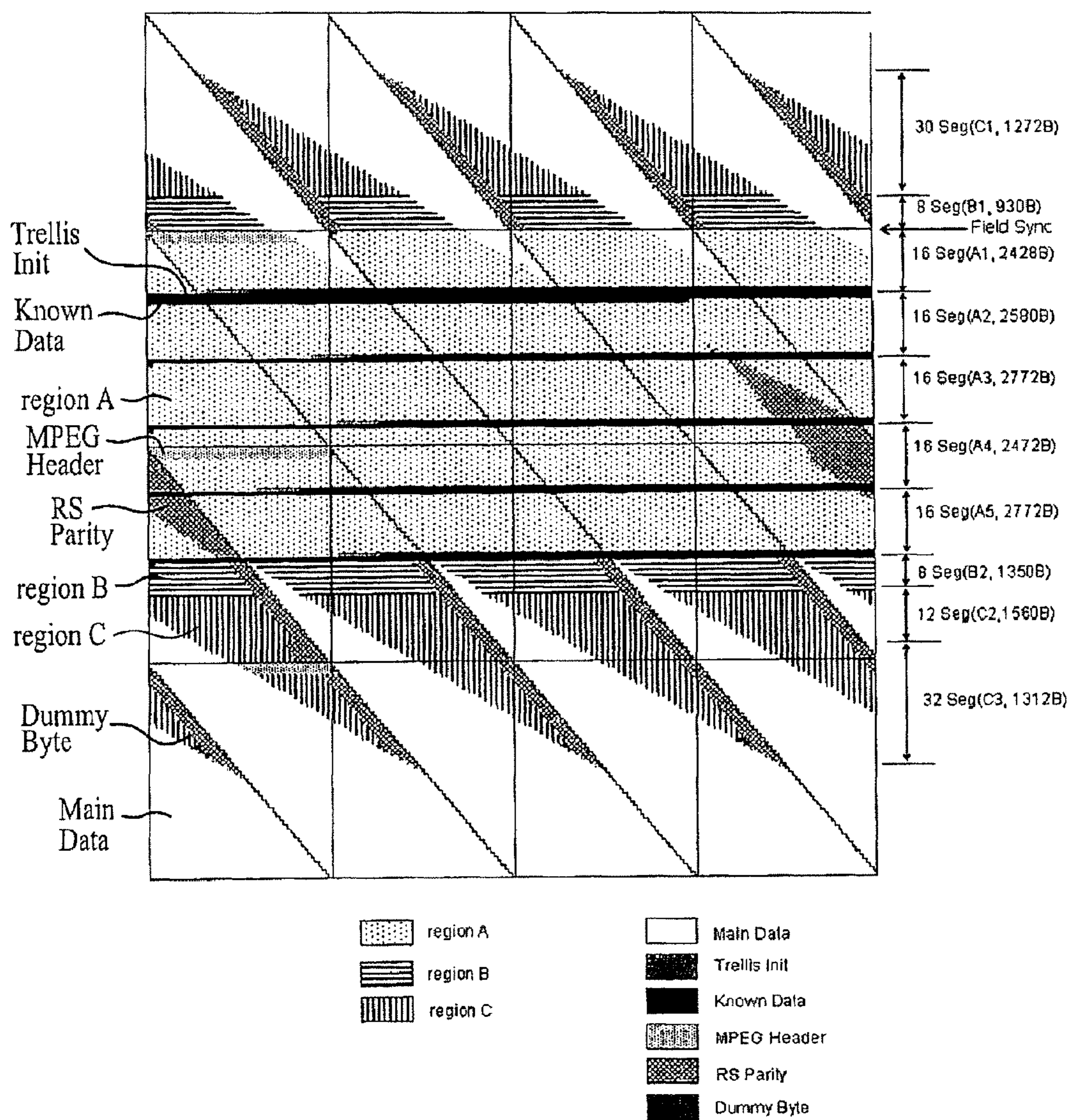

FIG. 6B

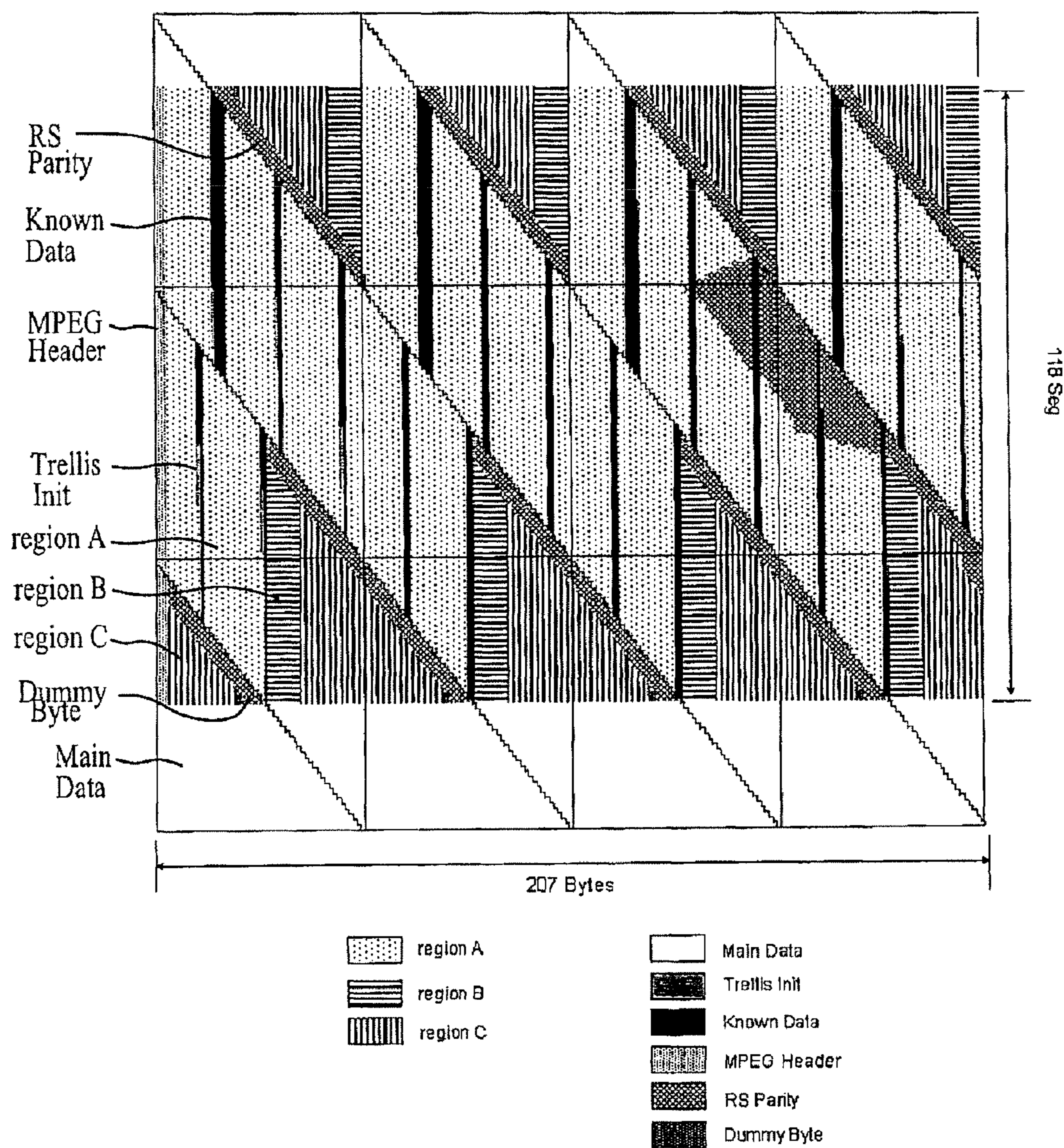

FIG. 7

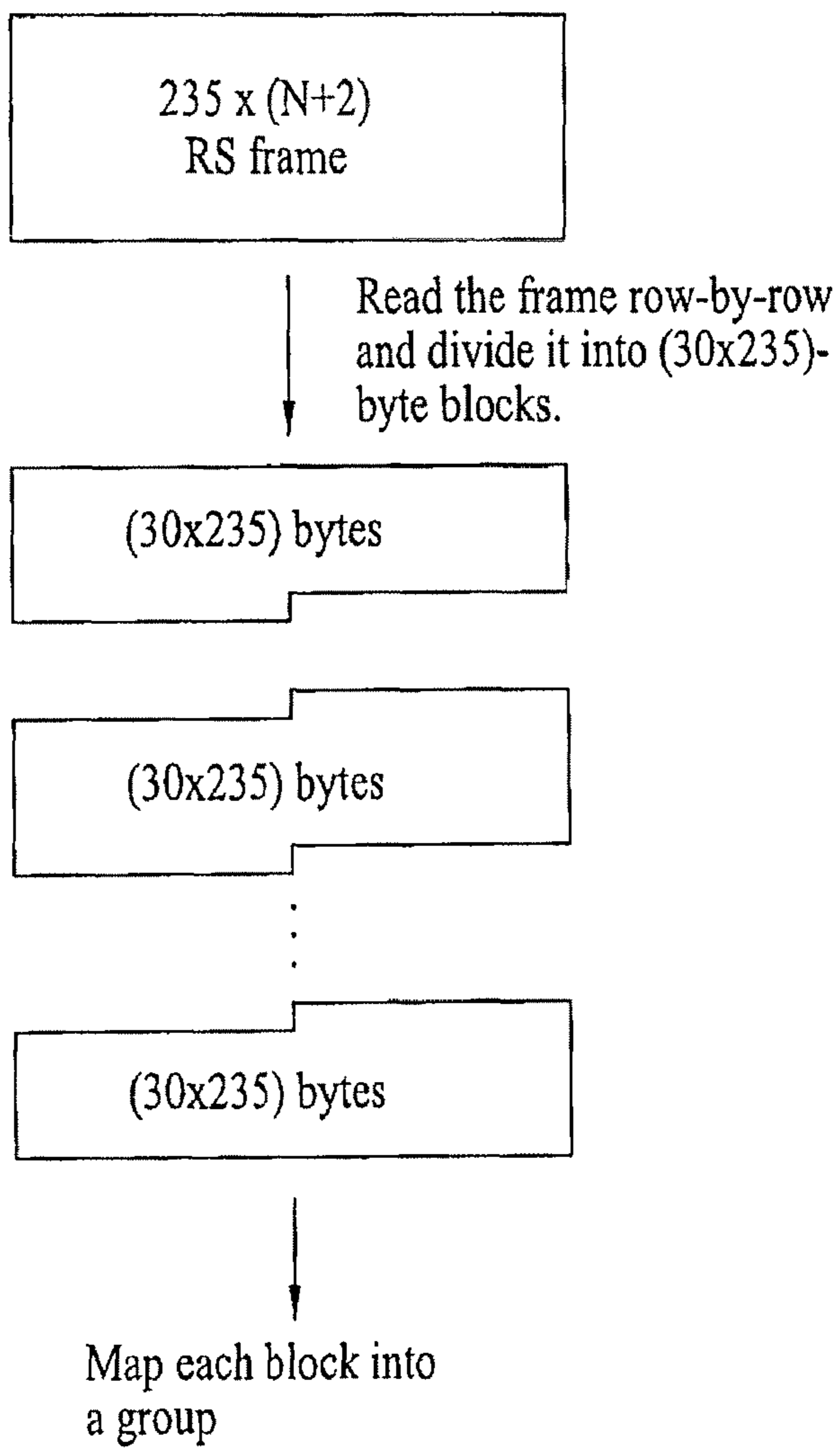

FIG. 8

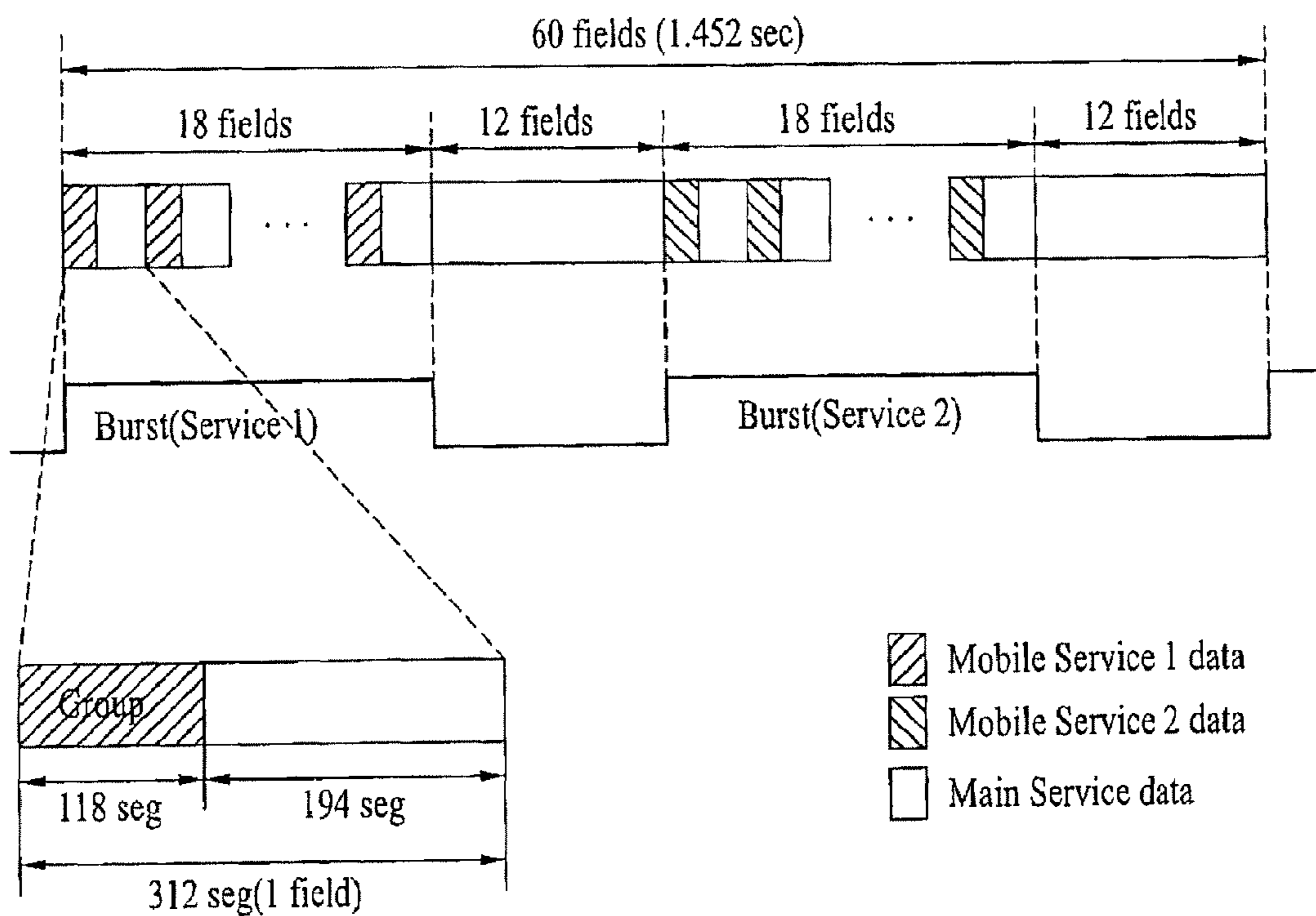

FIG. 9

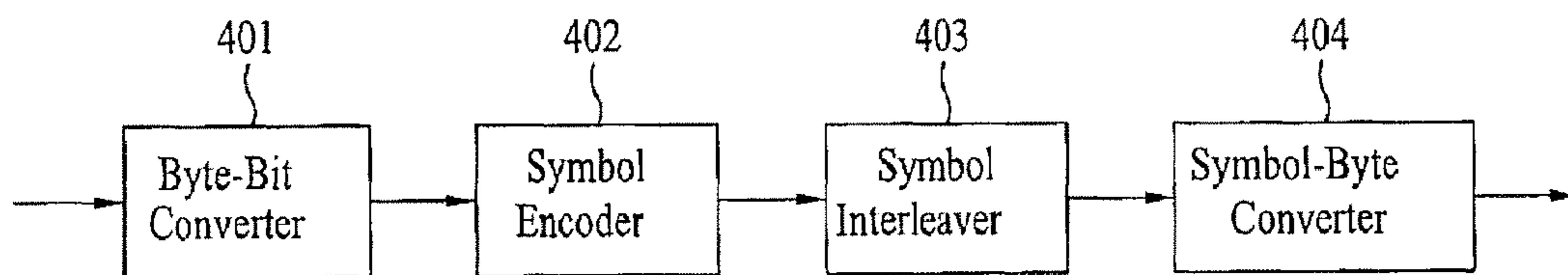

FIG. 10

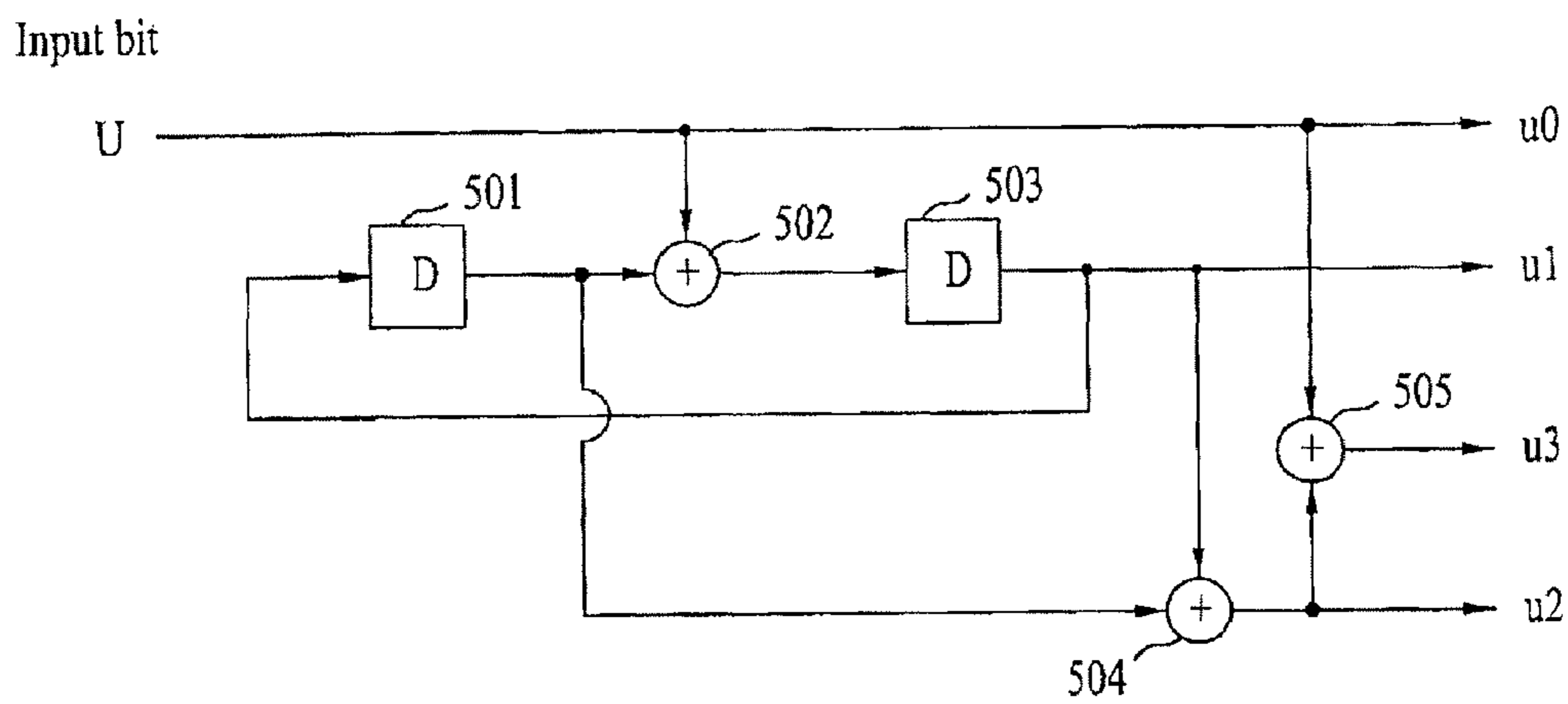

FIG. 11

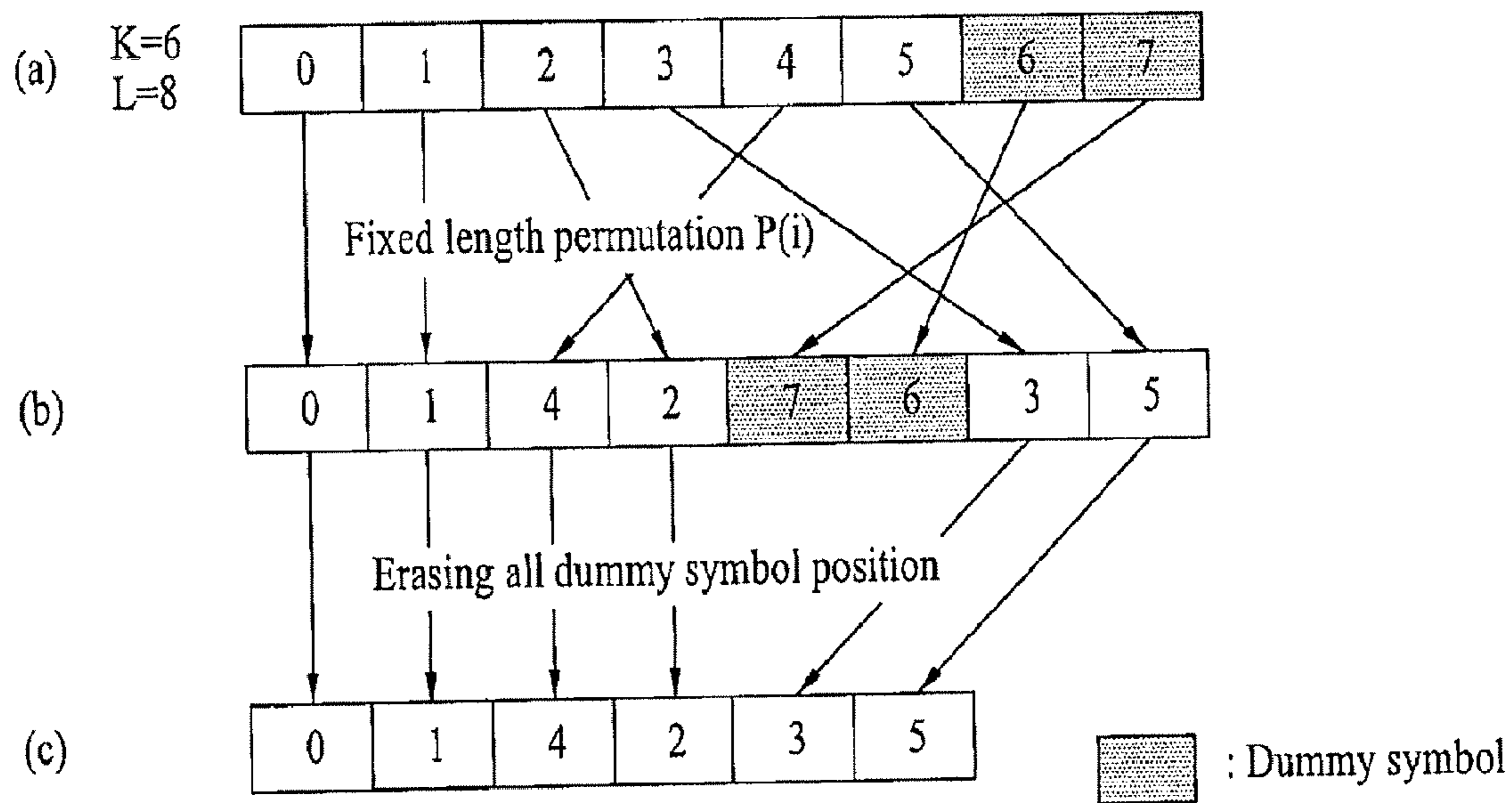

FIG. 12A

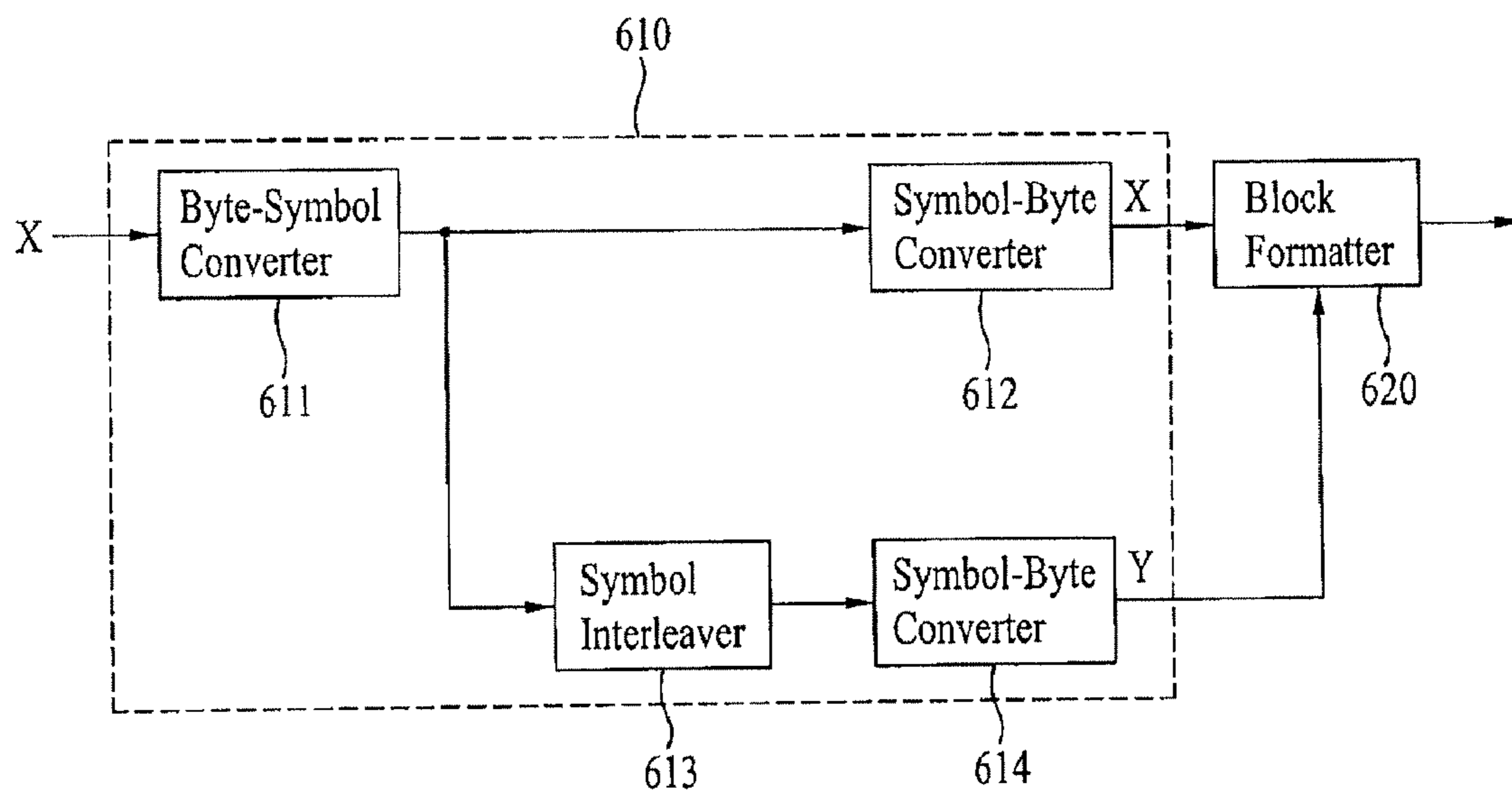

FIG. 12B

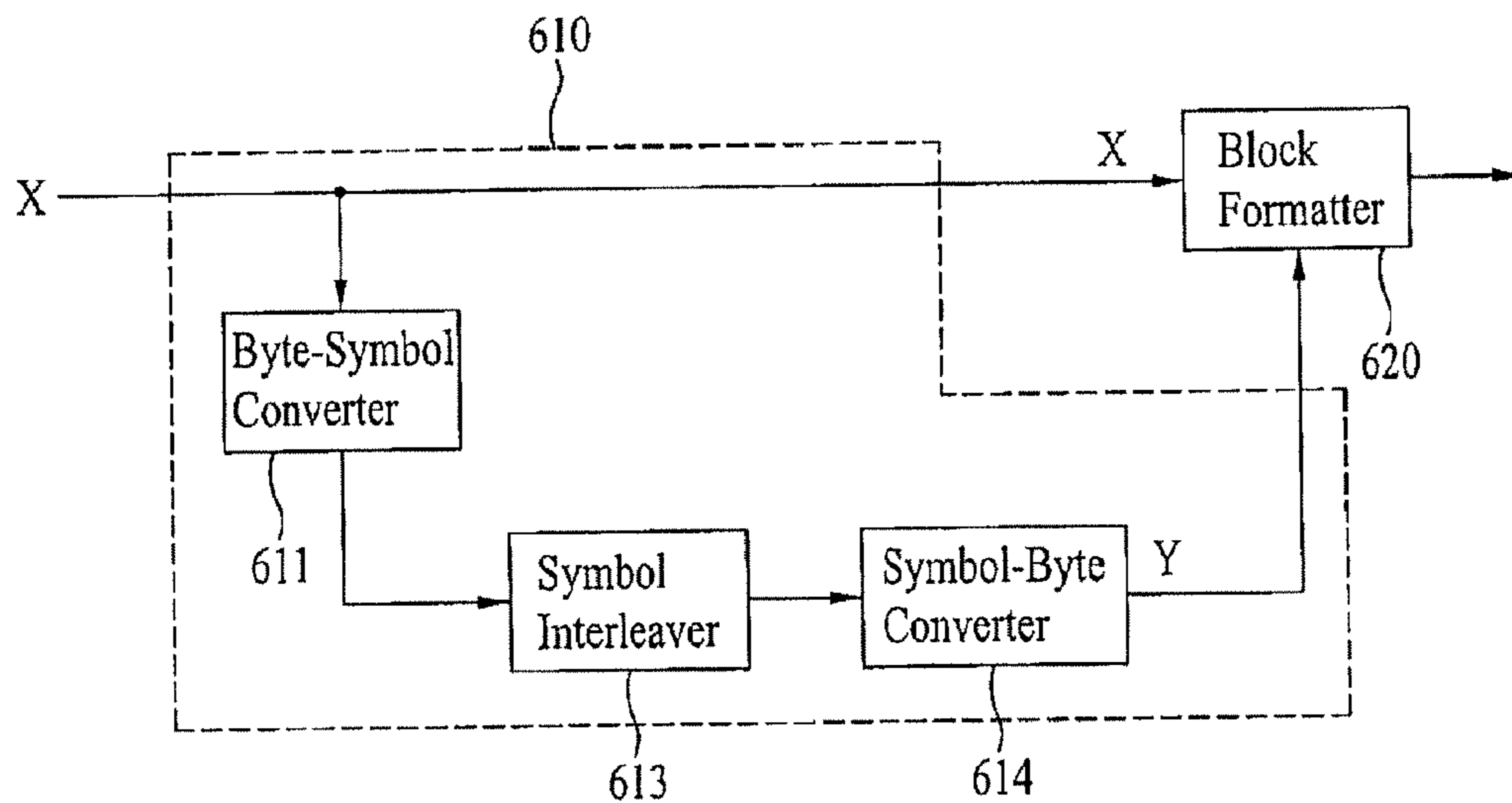

FIG. 13

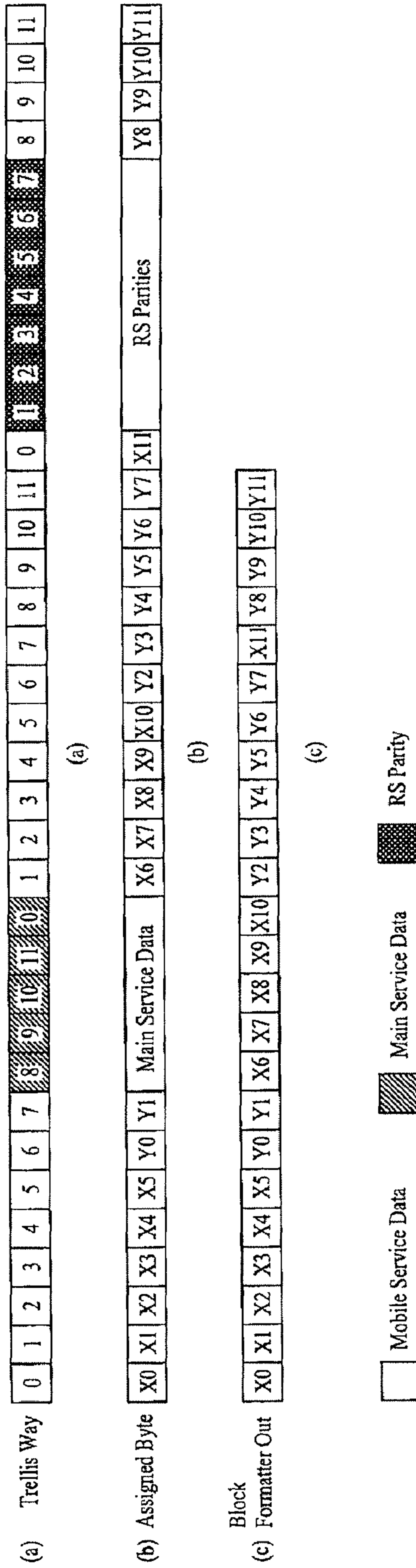

FIG. 14

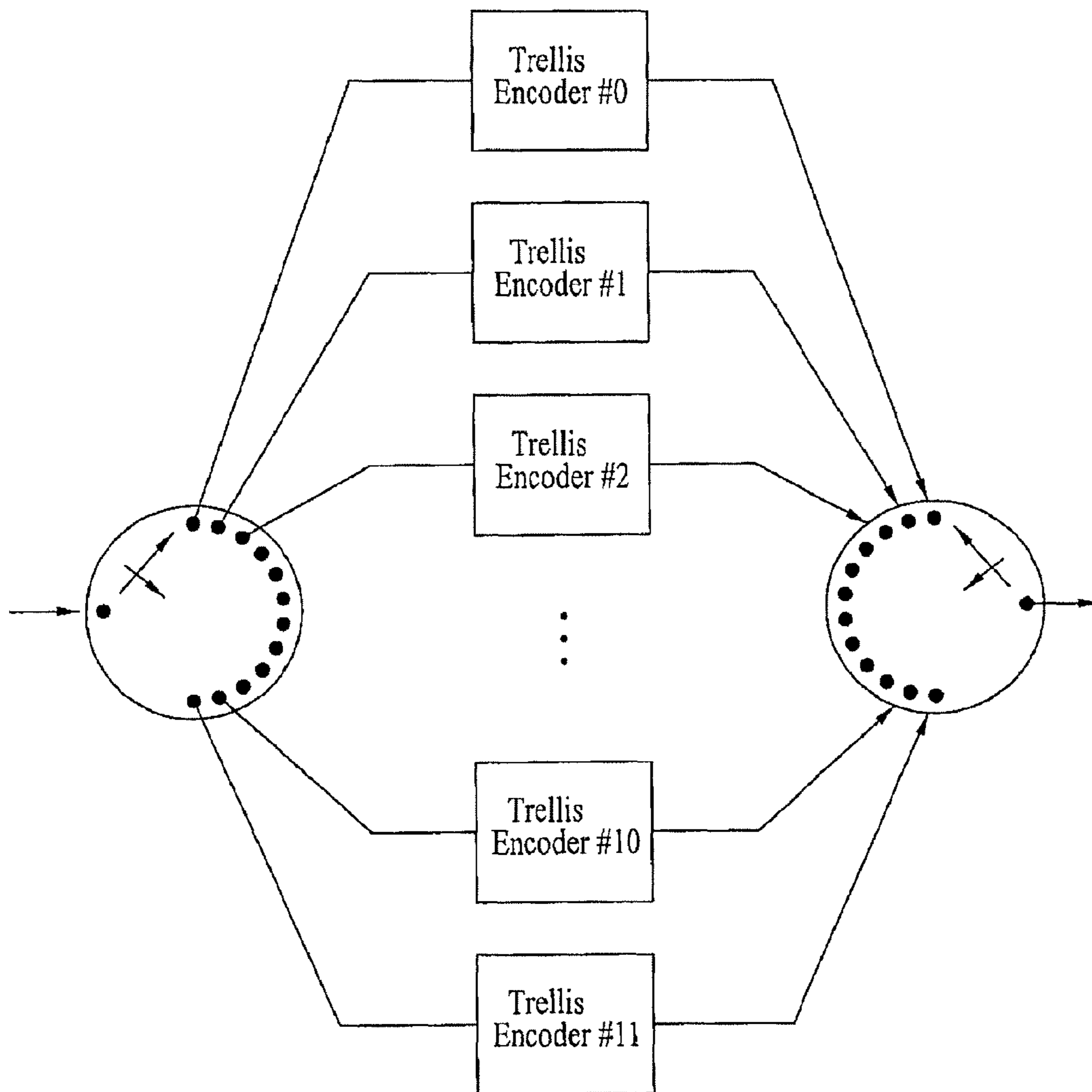

FIG. 15A

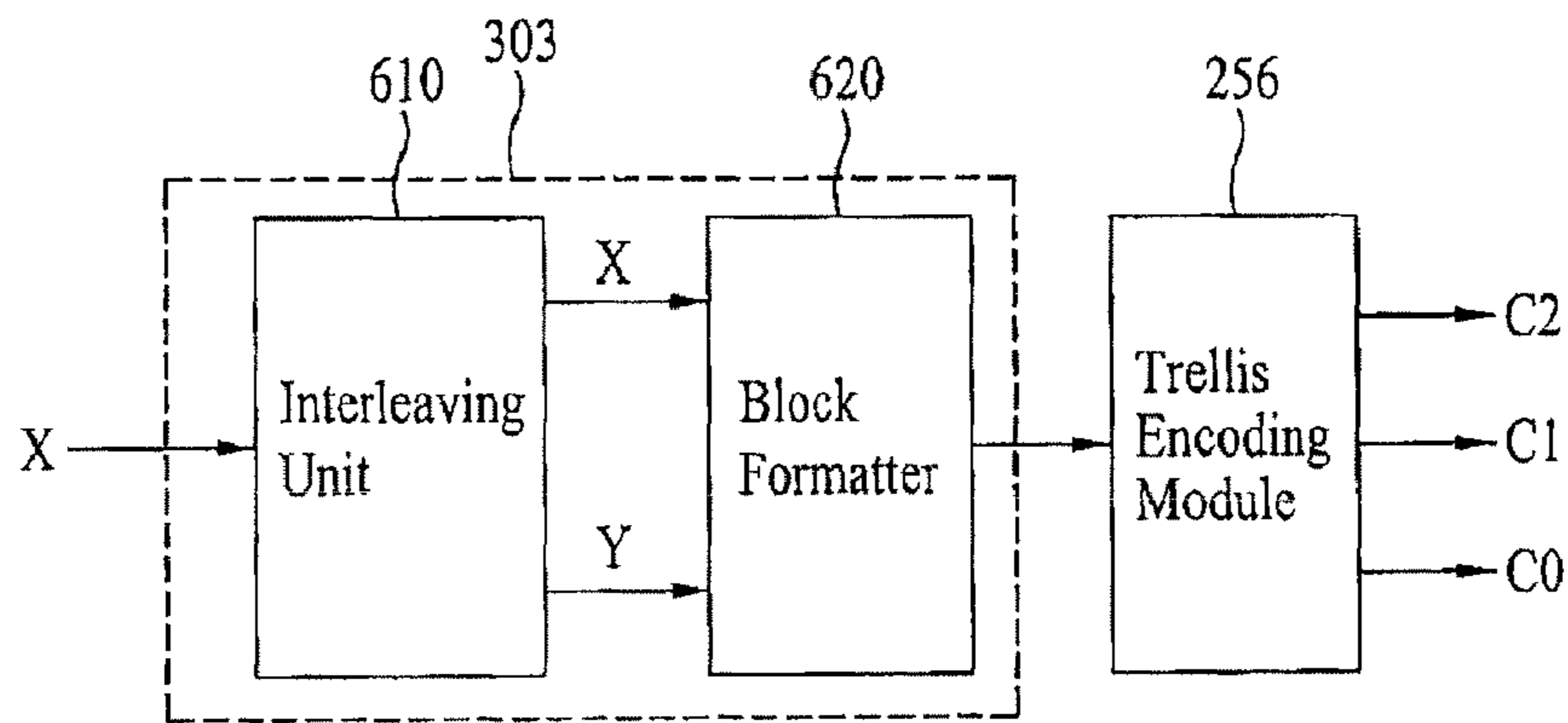

FIG. 15B

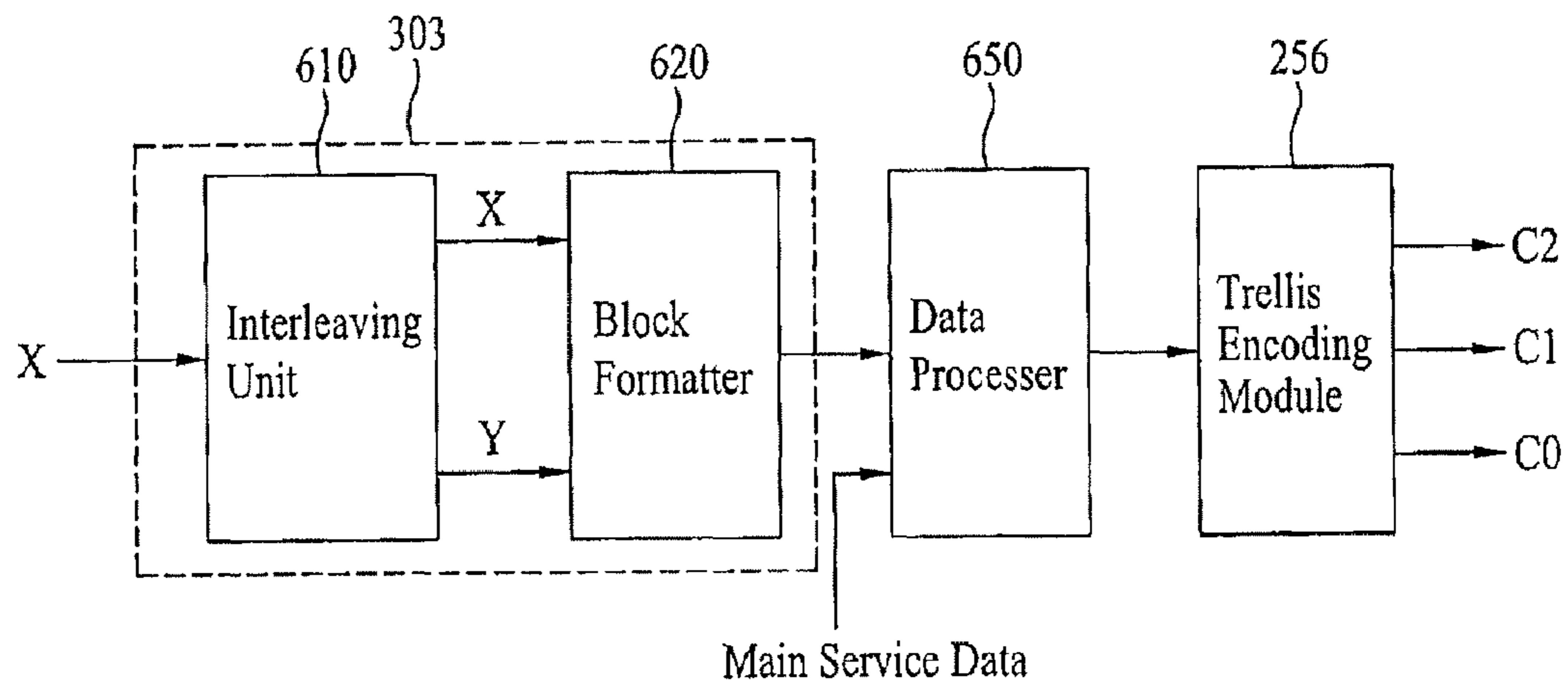

FIG. 16

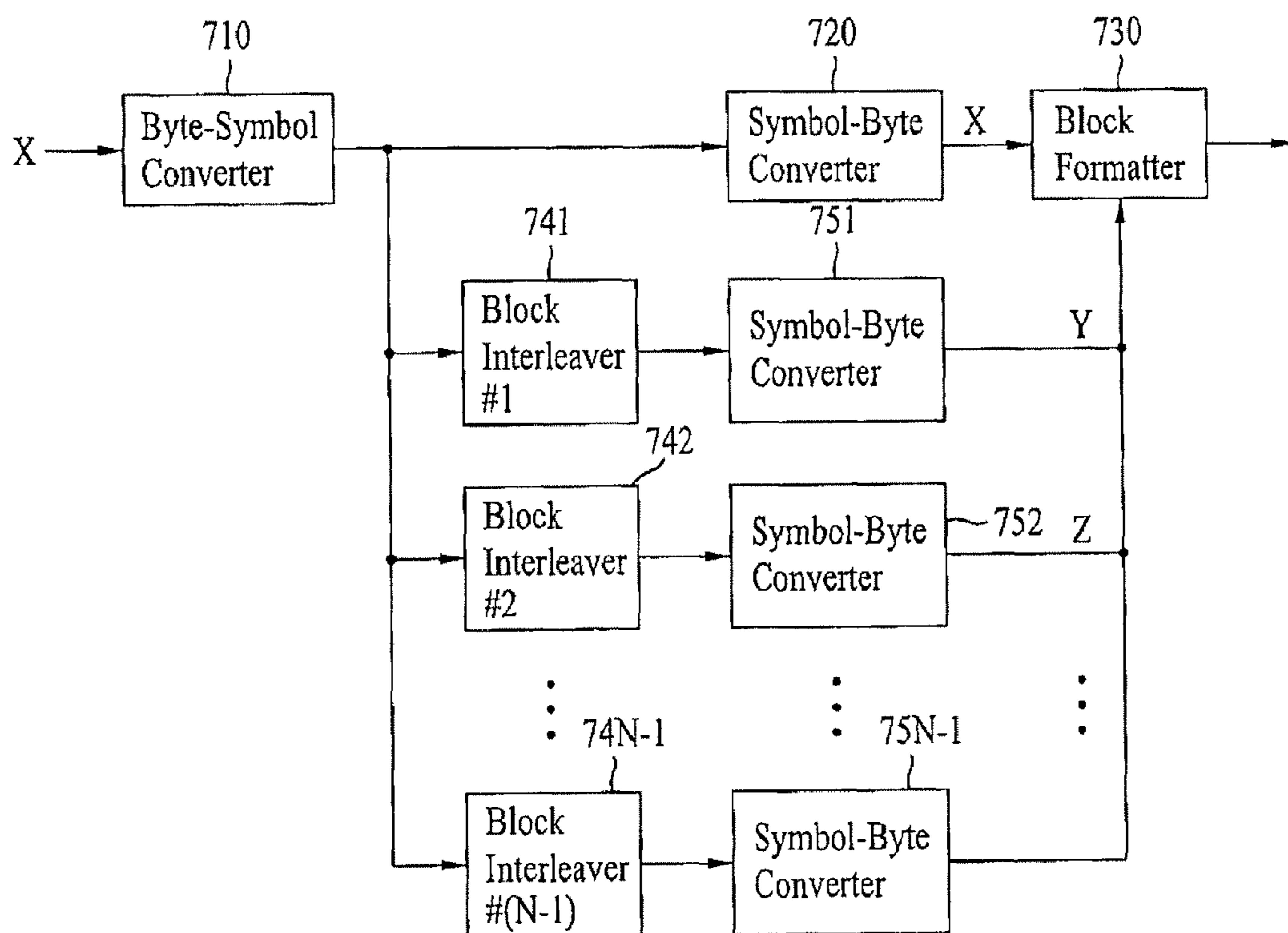

FIG. 17

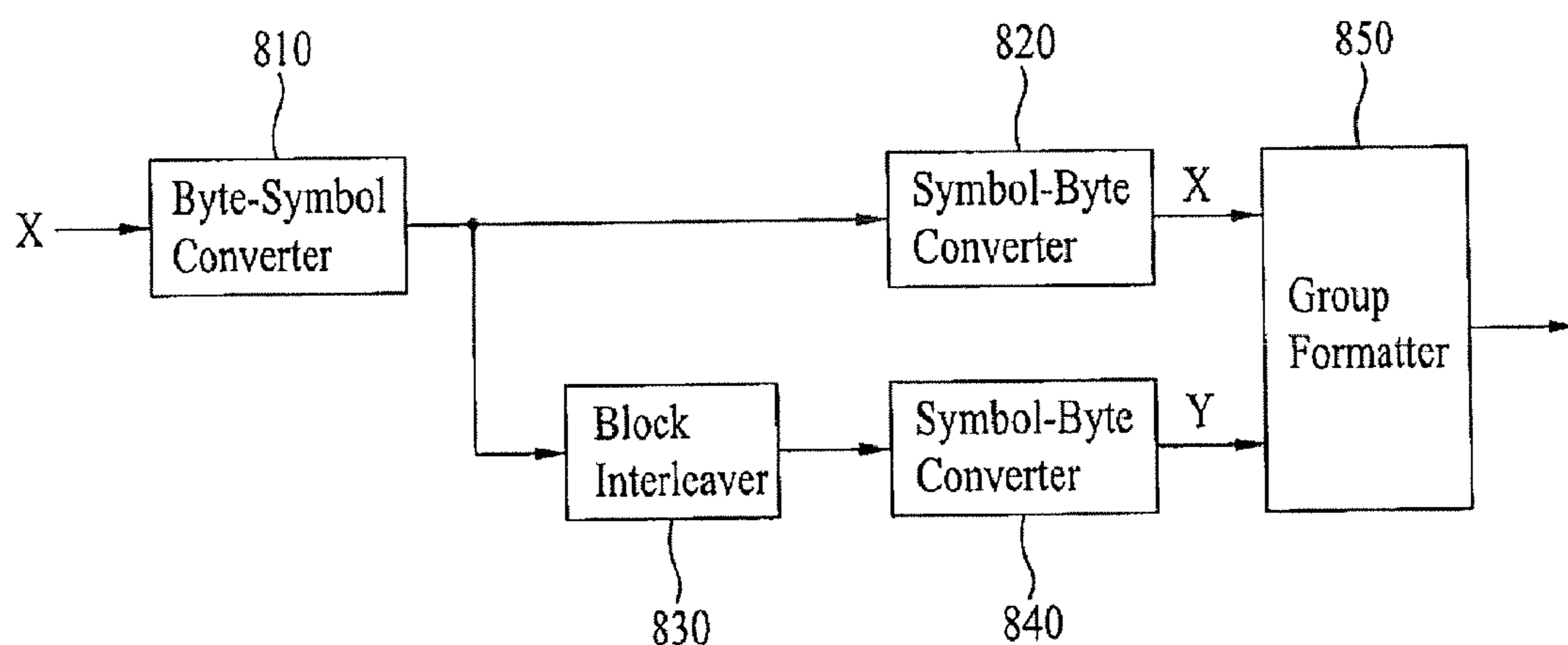

FIG. 18

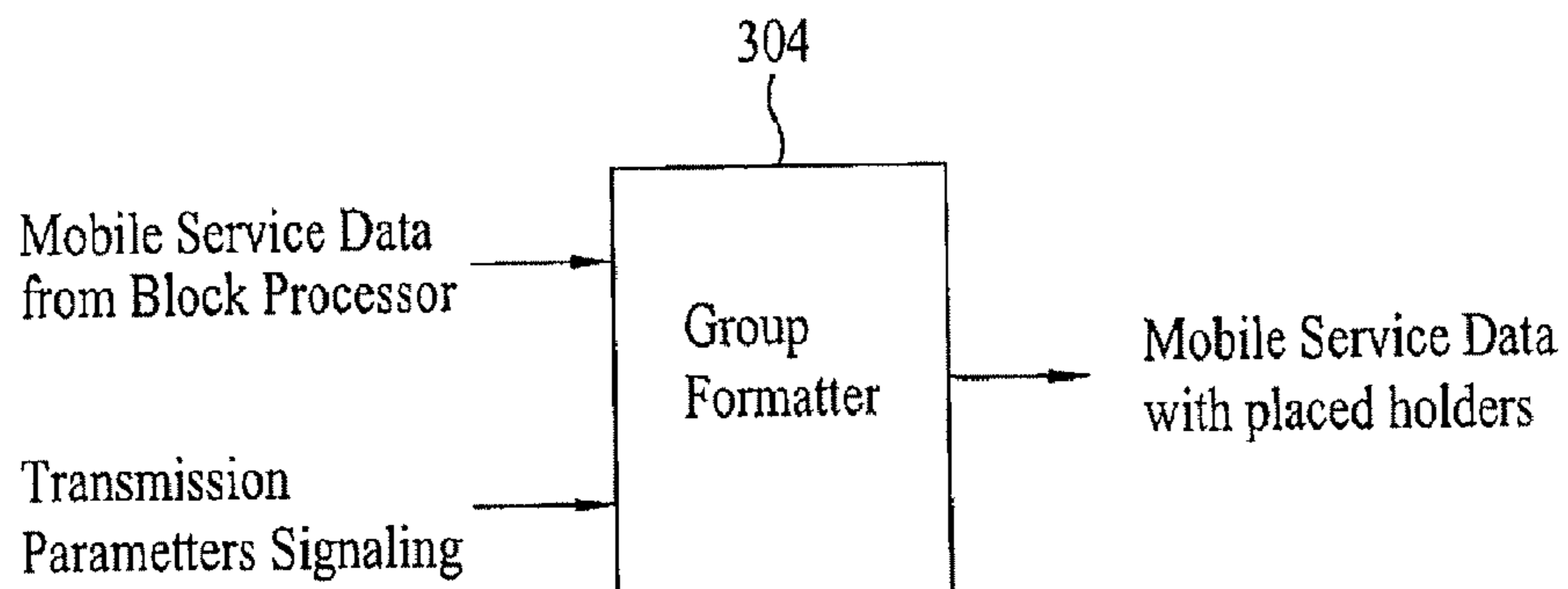

FIG. 19

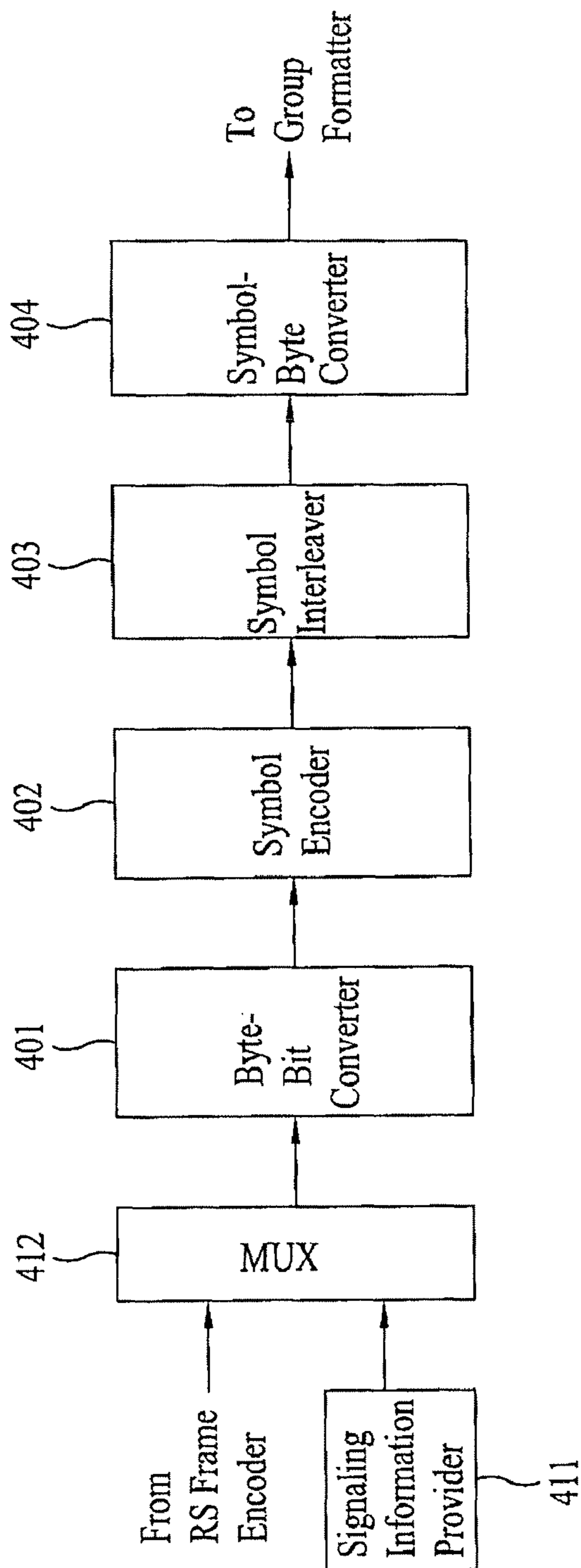

FIG. 20

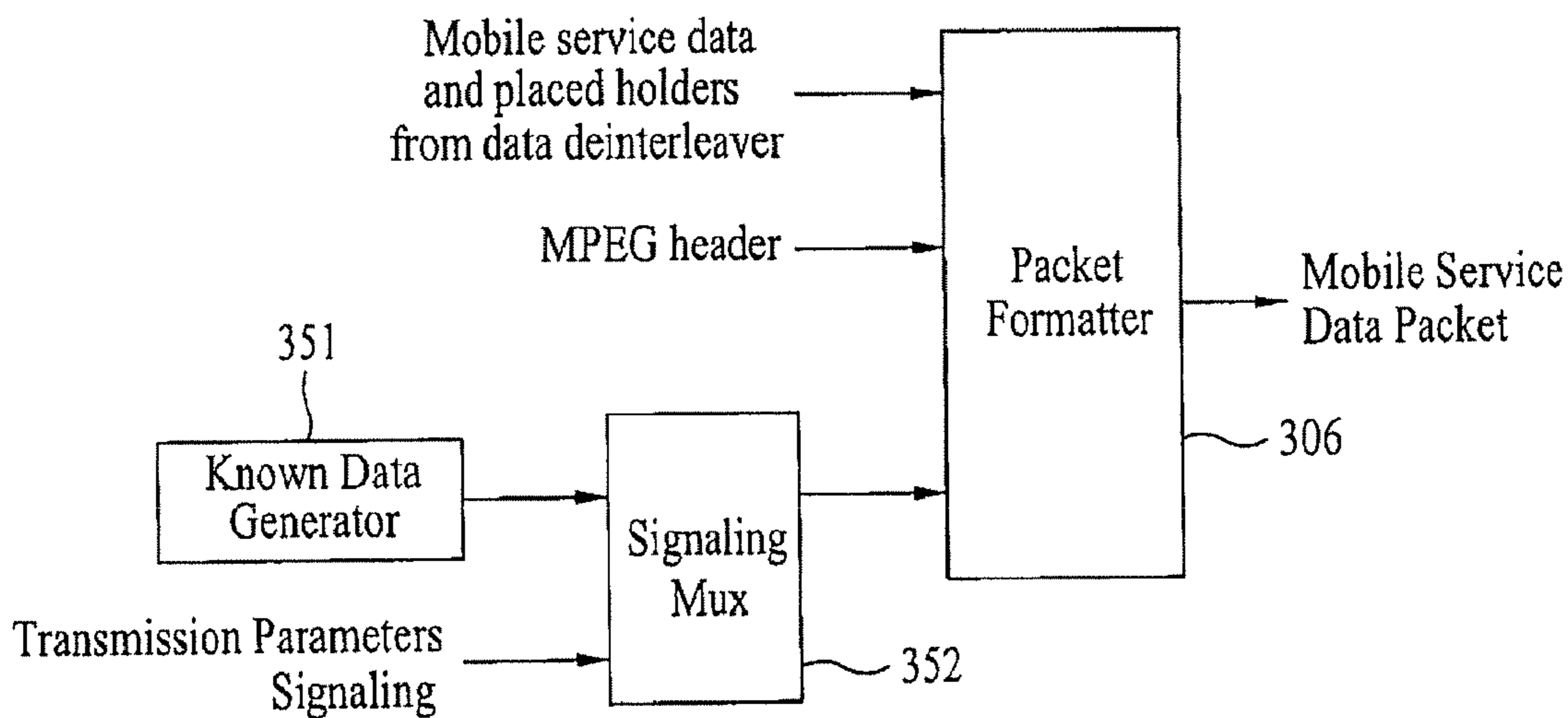

FIG. 21

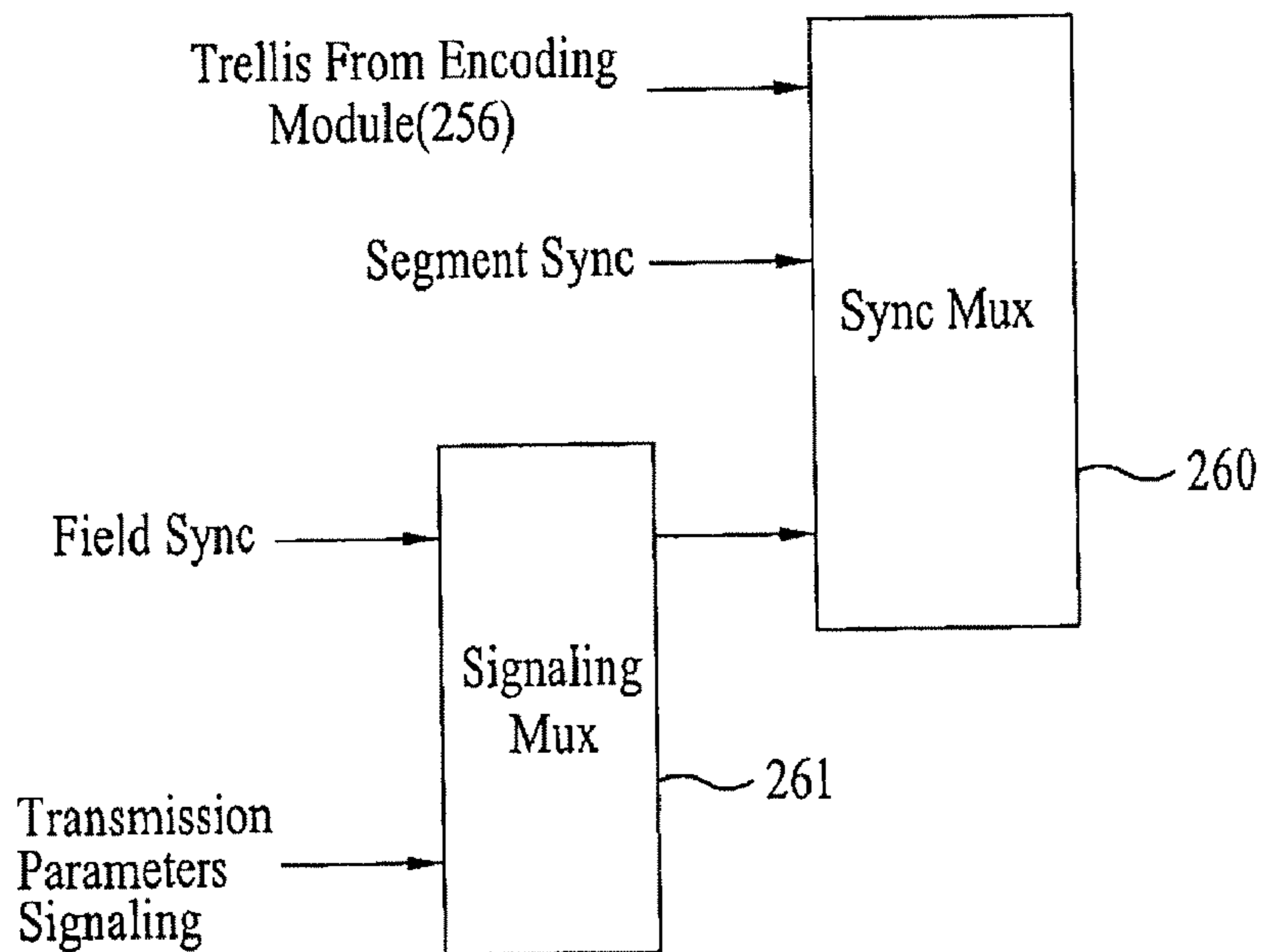

FIG. 22

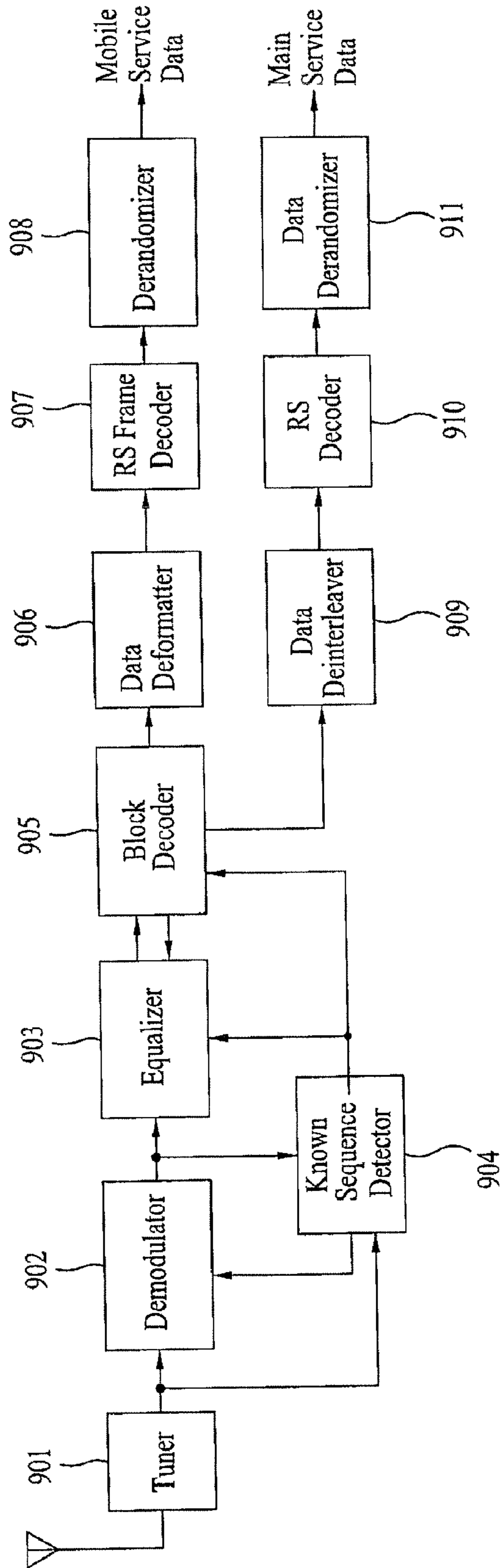

FIG. 23

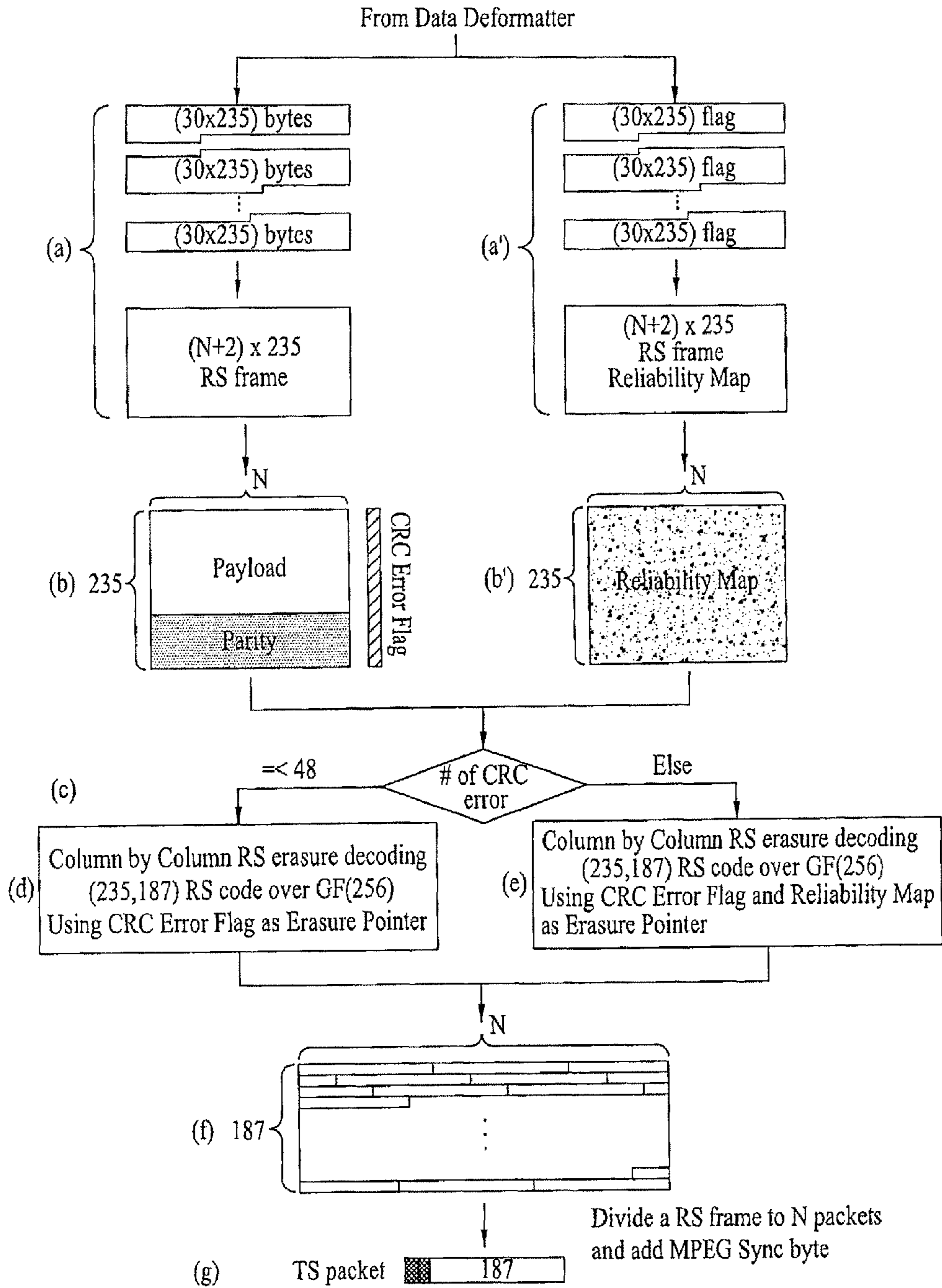

FIG. 24

Syntax	No. of bits	Format
system_time_table_section() {		
table_id	8	uimsbf
section_syntax_indicator	1	bslbf
private_indicator	1	bslbf
reserved	2	bslbf
section_length	12	uimsbf
table_id_extension	16	uimsbf
reserved	2	bslbf
version_number	5	uimsbf
current_next_indicator	1	bslbf
section_number	8	uimsbf
last_section_number	8	uimsbf
protocol_version	8	bslbf
system_time	32	uimsbf
GPS.UTC_offset	8	bslbf
daylight_savings	16	uimsbf
for(i=0; i<; i++) {		
descriptor()		
}		
CRC_32	32	rpchof
}		

FIG. 25

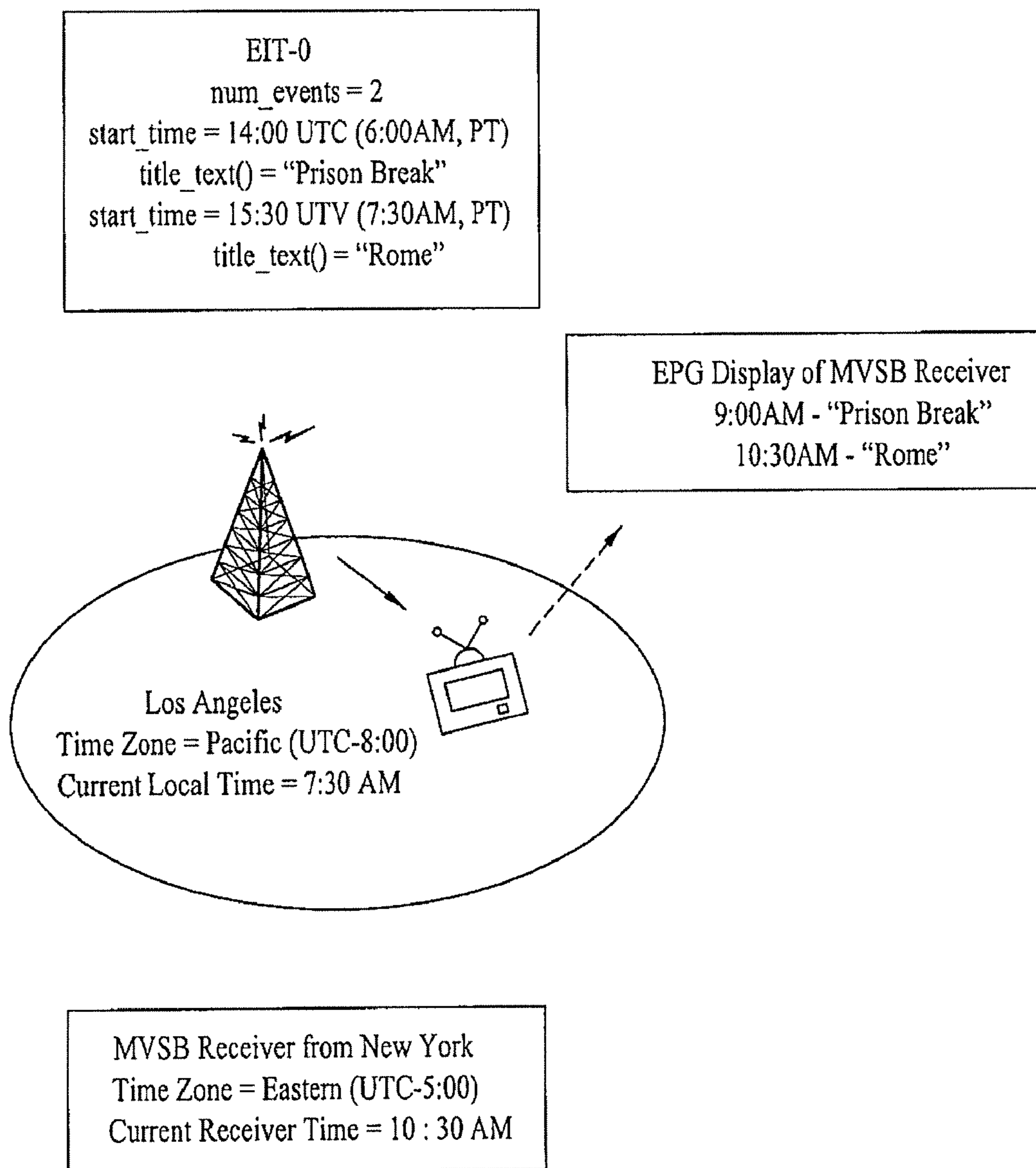

FIG. 26

Syntax	No. of bits	Format
time_zone_descriptor() {		
descriptor_tag	8	Uimbsf
descriptor_length	8	Uimbsf
for(i=0; i<N; i++) {		
time_zone_name_length	8	Uimbsf
time_zone_name	var	
time_zone_id	7	Uimbsf
time_zone_offset_polarity	1	boolean
time_zone_offset	32	uimbsf
}		
}		

FIG. 27

	Time_zone_name	Time_zone_id	Time_zone_offset_polarity	Time_zone_offset
EST	Eastern	0x00	1	5hrs
CT	Central	0x01	1	6hrs
MT	Mountain	0x02	1	7hrs
PT	Pacific	0x03	1	8hrs
Alaska	Alaska	0x04	1	9hrs
Hawaii	Hawaii	0x05	1	10hrs

FIG. 28

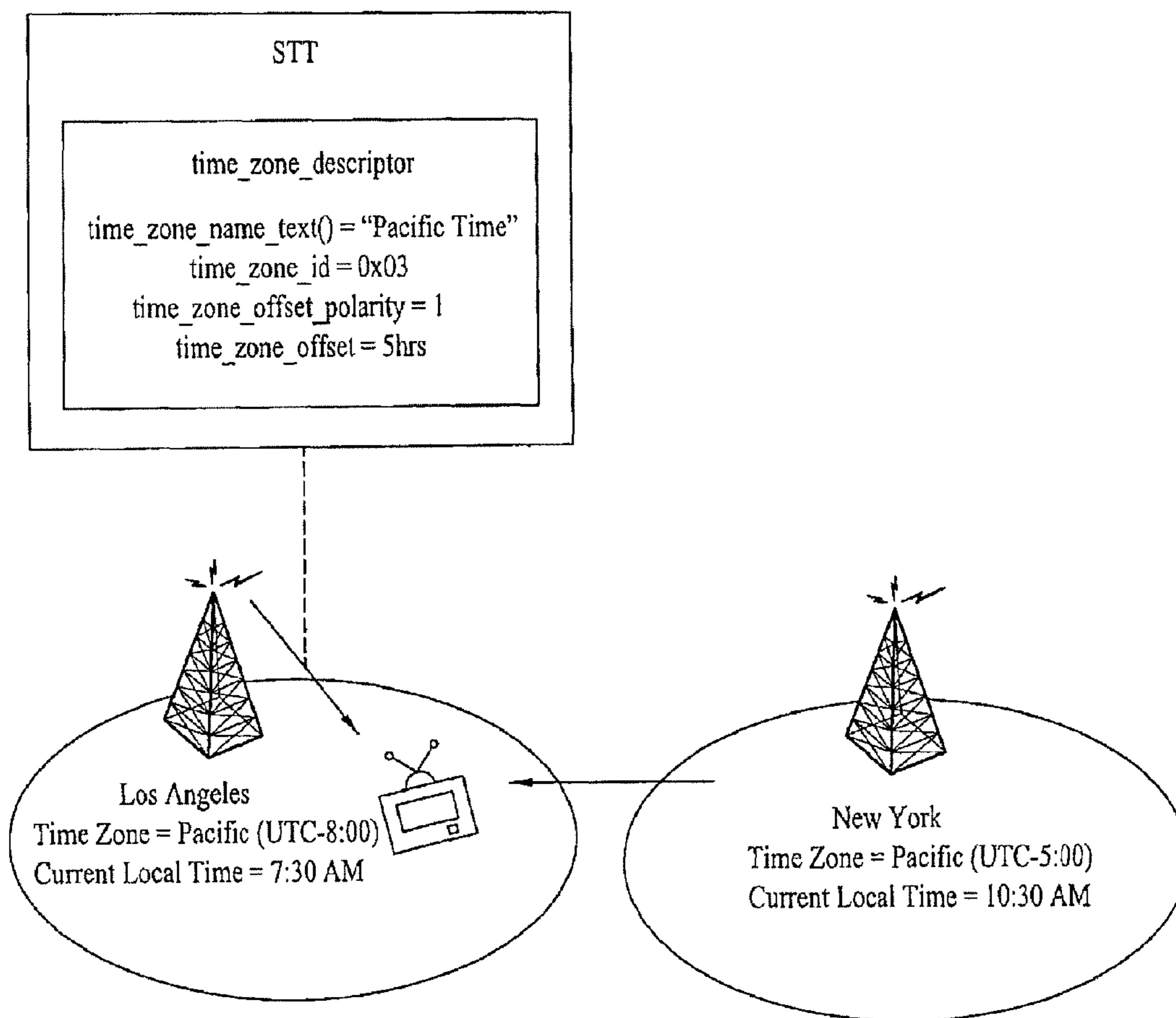

FIG. 29

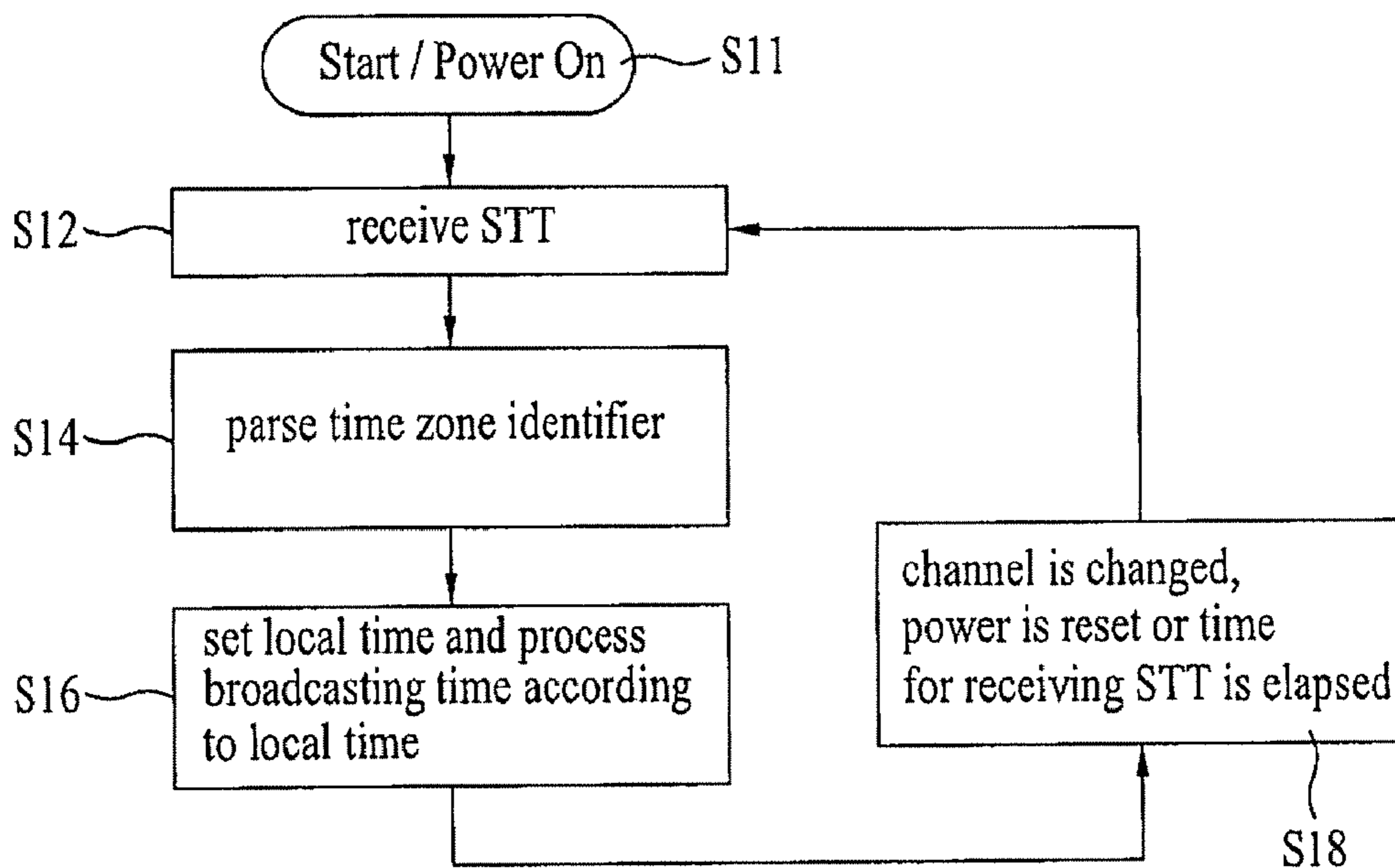

FIG. 30

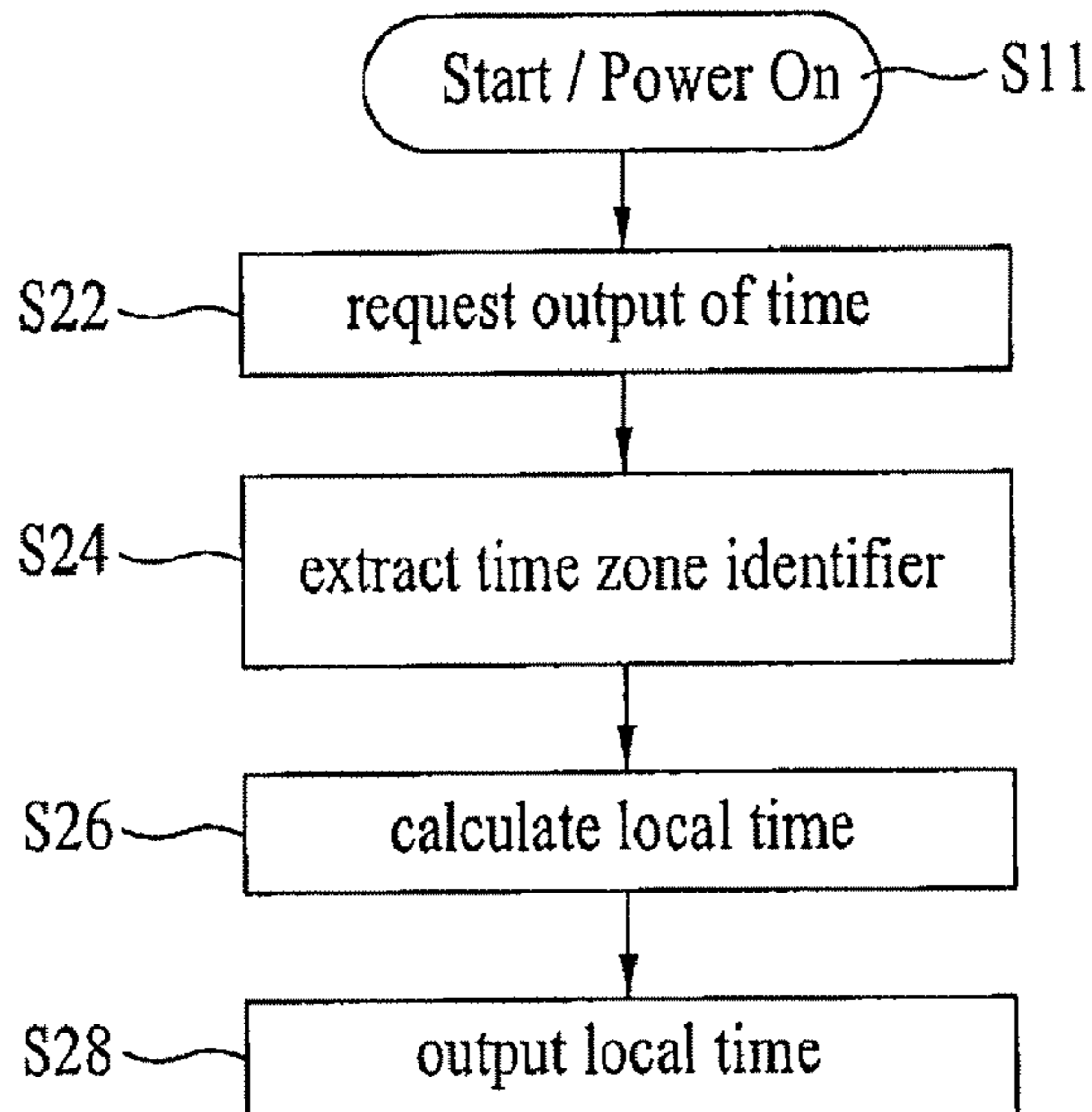

FIG. 31

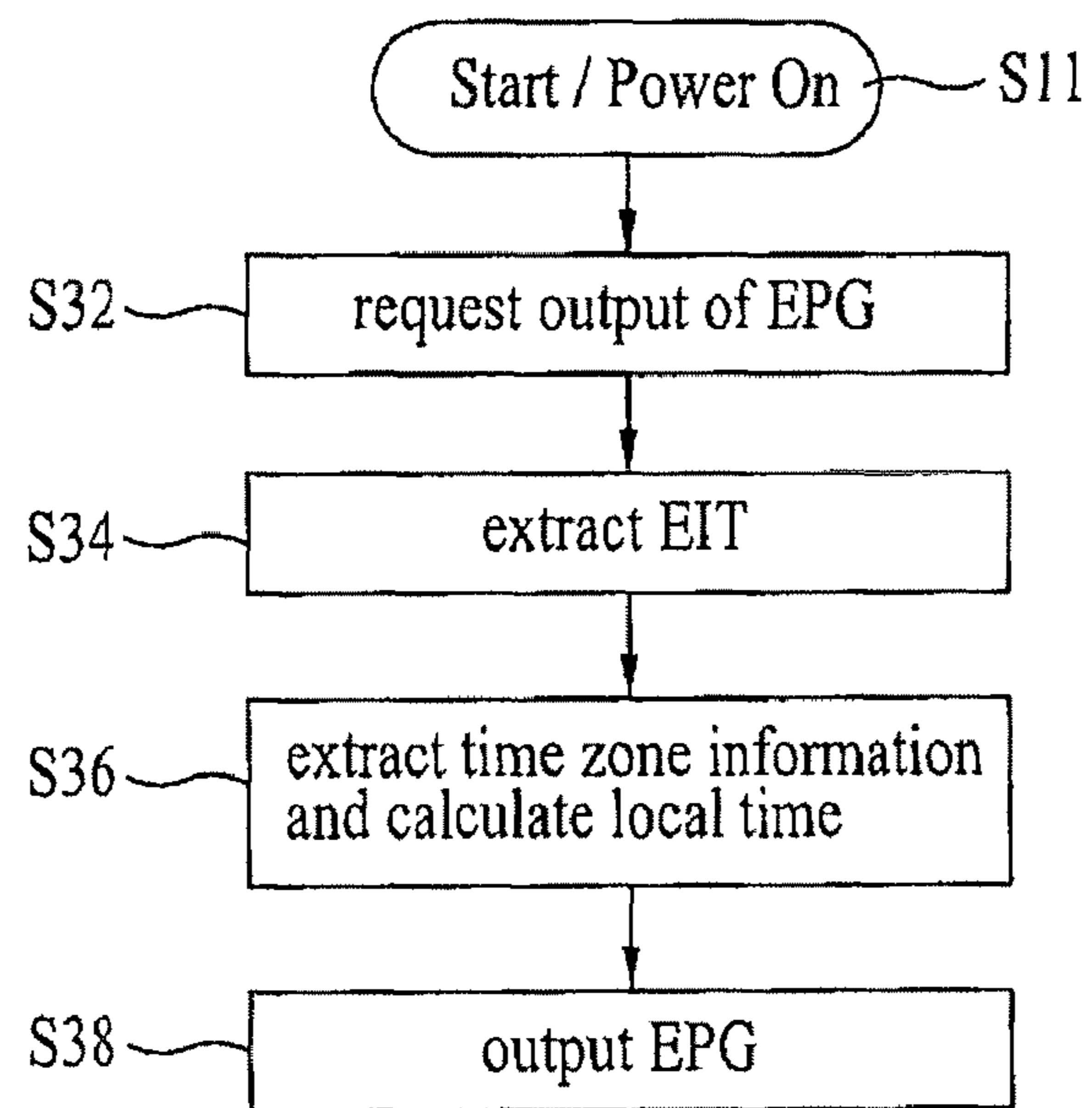

FIG. 32

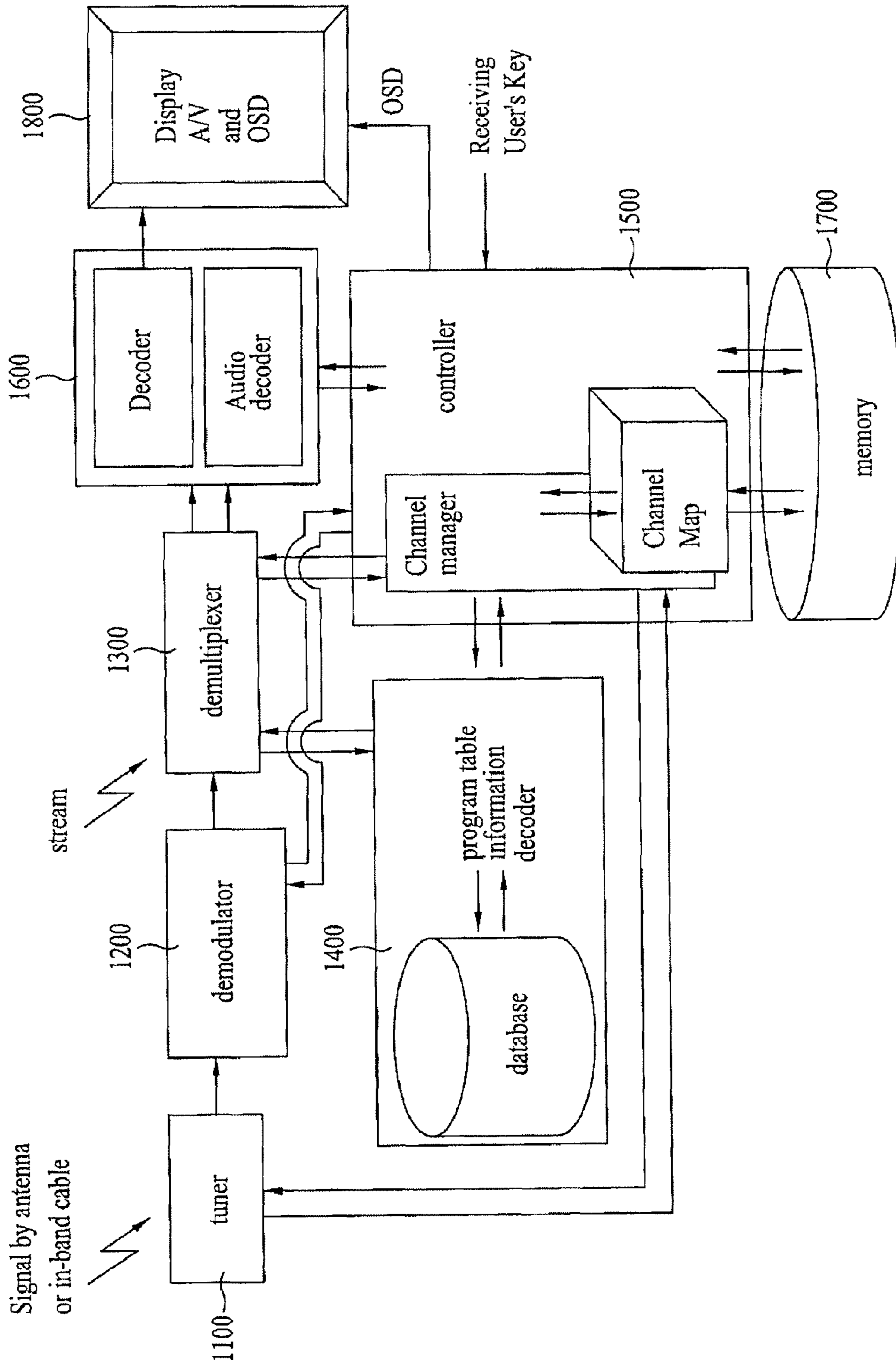
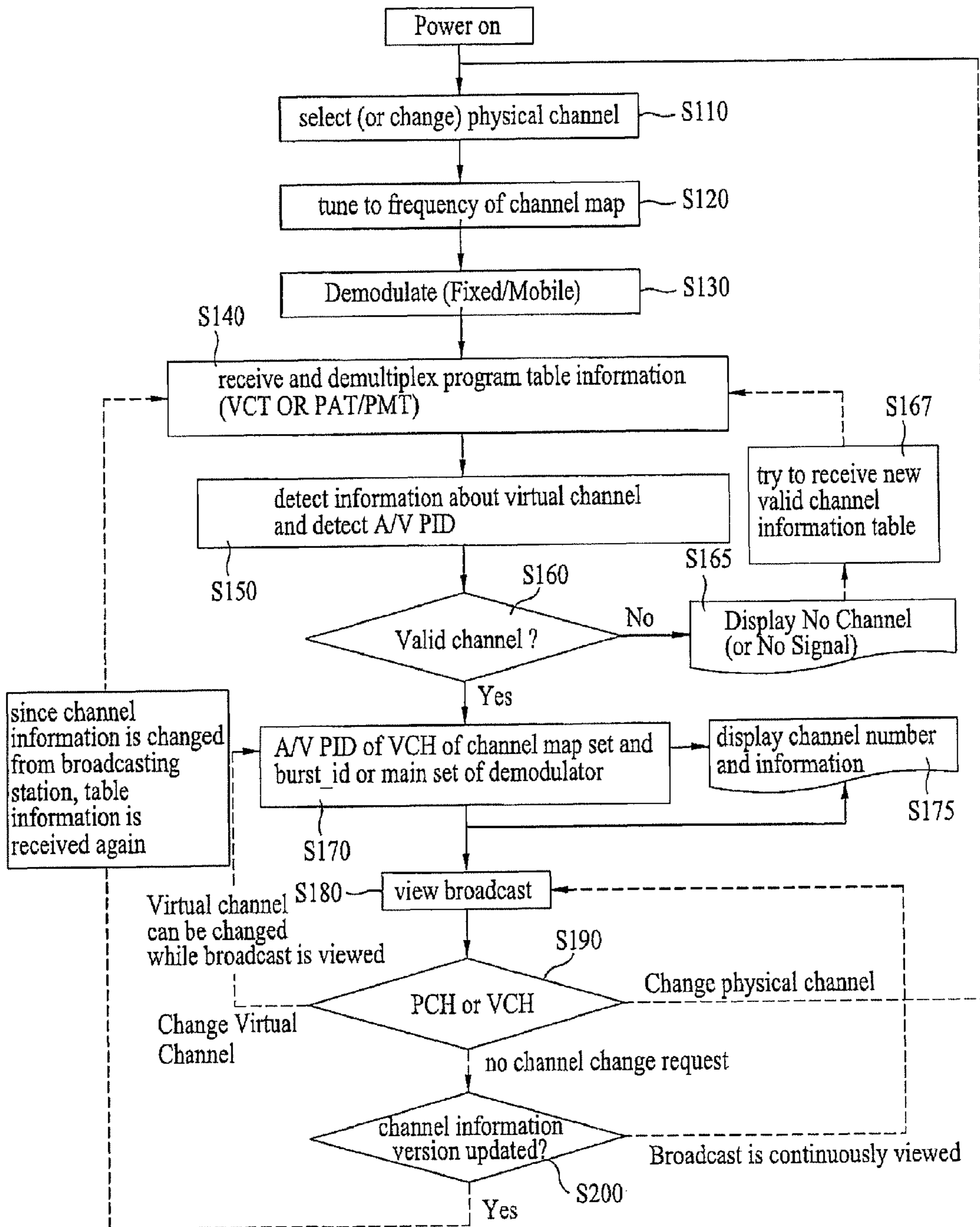

FIG. 33



DIGITAL BROADCASTING SYSTEM AND DATA PROCESSING METHOD

Matter enclosed in heavy brackets [] appears in the original patent but forms no part of this reissue specification; matter printed in italics indicates the additions made by reissue; a claim printed with strikethrough indicates that the claim was canceled, disclaimed, or held invalid by a prior post-patent action or proceeding.

More than one reissue application has been filed for the reissue of U.S. Pat. No. 8,443,412, including U.S. patent application Ser. No. 15/833,841 (the present application) and U.S. patent application Ser. No. 14/711,531, now U.S. Pat. No. RE46676.

This application is a continuation reissue of U.S. patent application Ser. No. 14/711,531, filed May 13, 2015, which is a reissue of U.S. Pat. No. 8,443,412, now RE46676, which issued on May 14, 2013, from U.S. application Ser. No. 13/051,743, filed on Mar. 18, 2011, which is a continuation of U.S. application Ser. No. 12/100,573, filed on Apr. 10, 2008, now U.S. Pat. No. 7,934,243, which claims the benefit of earlier filing date and right to priority to Korean Application No. 10-2007-0036234, filed on Apr. 13, 2007, and claims the benefit of U.S. Provisional Application Nos. 60/911,812, filed on Apr. 13, 2007, and 60/947,984, filed on [and] Jul. 4, 2007, the contents of which are all hereby incorporated by reference in their entirety.

BACKGROUND OF THE INVENTION

1. Field of the Invention

The present invention relates to a digital broadcasting system and a data processing method.

2. Discussion of the Related Art

A digital broadcasting system which can deliver a variety of broadcasting contents has come into wide use. For example, since a vestigial sideband (VSB) transmission scheme is employed as the digital broadcasting standard in North America and Korea, users can transmit/receive a variety of broadcasting programs. The VSB transmission scheme which is employed as the digital broadcasting standard in North America and Korea uses a single carrier scheme. A broadcast receiving system obtains system information necessary for transmitting/receiving a broadcast from a broadcast transmitting system through a program and system information protocol.

SUMMARY OF THE INVENTION

Accordingly, the present invention is directed to a digital broadcasting system and a data processing method that substantially obviate one or more problems due to limitations and disadvantages of the related art.

An object of the present invention is to provide a digital broadcasting system and a data processing method which are robust against channel change and noise.

Another object of the present invention is to provide a digital broadcasting system and a data processing method, which are capable of improving reception capability of a reception system by performing additional encoding processes with respect to mobile service data and transmitting the encoded mobile service data to the reception system.

Another object of the present invention is to provide a digital broadcasting system and a data processing method,

which are capable of improving reception capability of a reception system by inserting known data into a predetermined region of a data region and transmitting the data by an appointment of a transmitter and a receiver.

A further object of the present invention is to provide a digital broadcasting system and a data processing method, which are capable of coping with a time change according to mobile reception.

Additional advantages, objects, and features of the invention will be set forth in part in the description which follows and in part will become apparent to those having ordinary skill in the art upon examination of the following or may be learned from practice of the invention. The objectives and other advantages of the invention may be realized and attained by the structure particularly pointed out in the written description and claims hereof as well as the appended drawings.

To achieve these objects and other advantages and in accordance with the purpose of the invention, as embodied and broadly described herein, a data processing method including receiving a broadcasting signal including program table information having a time zone identifier of a region in which a broadcast receiving system is located. The program table information is parsed and the time zone identifier and a time difference between a local time of the region, in which the broadcast receiving system is located, and a standard time are obtained. The local time of the region, in which the broadcast receiving system is located, is obtained from the time zone identifier and the time difference between the local time of the region and the standard time.

The data processing method may include processing information related to the local time in information processed by the broadcast receiving system on the basis of the obtained local time.

The program table information may be a system time table (STT).

The program table information may further include polarity information indicating whether the local time of the time zone identifier is earlier or later than the standard time from the time difference.

The program table information may include a time difference between the local time according to the time zone identifier and the standard time.

The obtaining of the local time may include storing time zone identifiers and local times corresponding to time zones identified by the time zone identifiers and obtaining any one of the stored local times according to the obtained time zone identifier.

According to another aspect of the present invention, a data processing method includes multiplexing mobile service data including program table information having a time zone identifier with broadcasting contents and outputting a broadcasting stream. The broadcasting stream is modulated and the modulated broadcasting stream is transmitted.

The broadcasting stream may be obtained by interleaving the mobile service data and main service data in the unit of a data group.

According to another aspect of the present invention, a digital broadcasting system includes a tuner receiving a broadcasting signal including a time zone identifier and outputting a channel selected by a user. And a demodulator demodulates mobile service data in the output broadcasting signal and outputting the demodulated broadcasting stream, a demultiplexer demultiplexes the broadcasting stream output from the demodulator. A program table information decoder obtains the time zone identifier from program table information demultiplexed by the demultiplexer and a

decoder decodes the broadcasting stream demultiplexed by the demultiplexer. And a display unit displays broadcasting contents according to the broadcasting stream decoded by the decoder and a controller obtains a local time using the time zone identifier and processes information related to the broadcasting signal according to the local time.

The digital broadcasting system may further include a memory storing time zone identifiers and local times corresponding to time zones identified by the time zone identifiers, and the controller may obtain any one of the local times stored in the memory according to the obtained time zone identifier.

If the memory stores the program information decoded by the program table information decoder, the controller may control the stored program information to be changed and stored according to the local time.

The digital broadcasting system may further include an interface receiving a control signal for outputting broadcasting program guide information from the user, and the controller may control the broadcasting program guide information to be output to the display unit according to the local time.

If the control signal for outputting the local time is received from the user, the controller may output the local time to the display unit.

According to another aspect of the present invention, a data processing method includes multiplexing program table information including a time difference between a time of a time zone, in which a digital broadcast receiving system is located, and a standard time with mobile service data including broadcasting contents and outputting a broadcasting stream; and transmitting a broadcasting signal obtained by modulating the output broadcasting stream.

If the signal is received, the program table information is obtained from the received broadcasting signal, the program table information is parsed, and the time difference is obtained. In addition, a local time of a region, in which the broadcast receiving system is located, is obtained from the time difference.

It is to be understood that both the foregoing general description and the following detailed description of the present invention are exemplary and explanatory and are intended to provide further explanation of the invention as claimed.

BRIEF DESCRIPTION OF THE DRAWINGS

The accompanying drawings, which are included to provide a further understanding of the invention and are incorporated in and constitute a part of this application, illustrate embodiment(s) of the invention and together with the description serve to explain the principle of the invention. In the drawings:

FIG. 1 is a block diagram showing a digital broadcast transmitting system according to an embodiment of the present invention;

FIG. 2 is a detailed block diagram showing an example of the service multiplexer;

FIG. 3 is a block diagram showing an example of the transmitter;

FIG. 4 is a block diagram showing an example of the pre-processor of FIG. 3;

FIG. 5 is a view showing an example of an RS frame encoding process;

FIGS. 6A and 6B are views showing the data structure of previous and next stages of a data deinterleaver in a digital broadcast transmitting system according to the present invention;

FIG. 7 is a view showing a process of dividing an RS frame;

FIG. 8 is a view showing the operation of a packet multiplexer;

FIG. 9 is a detailed block diagram showing an example of a block processor;

FIG. 10 is a detailed block diagram showing an example of a symbol encoder;

FIG. 11 is a view showing an example of a symbol interleaver;

FIG. 12A is a detailed block diagram showing an example of a block processor;

FIG. 12B is a detailed block showing another example of the block processor;

FIG. 13 is a view showing an example of aligning the output of a symbol-byte converter within a block in accordance with a set standard;

FIG. 14 is a detailed block diagram showing an example of a trellis encoding module;

FIG. 15A is a view showing the block processor which is concatenated with the trellis encoding module;

FIG. 15B is a view showing another example of the block processor and the trellis encoding module;

FIG. 16 is a block diagram showing an example of a block processor which performs an encoding process at a coding rate of $1/N$;

FIG. 17 is a detailed block diagram showing a block processor according to another embodiment of the present invention;

FIG. 18 is a schematic diagram of a group formatter which receives a transmission parameter and inserts the received transmission parameter in a body region of a data group;

FIG. 19 is a block diagram showing an example of the block processor which receives the transmission parameter and processes the received transmission parameter by the same process as the mobile service data;

FIG. 20 is a block diagram showing the structure of a packet formatter which is expanded so that the packet formatter can insert the transmission parameter;

FIG. 21 is a block diagram showing a synchronization multiplexer which is expanded in order to allow a transmission parameter to be inserted in a field synchronization segment region;

FIG. 22 is a block diagram showing a structure of a digital broadcast receiving system according to an embodiment of the present invention;

FIG. 23 is a view showing an error correction decoding process of an RS frame decoder;

FIG. 24 is a view showing a system time table (STT) which may be used in an ATSC system;

FIG. 25 is a view showing an example where the broadcast receiving system obtains time information;

FIG. 26 is a view showing the time information of a broadcasting signal including the time information according to regions;

FIG. 27 is a view showing the time information shown in FIG. 26;

FIG. 28 is a conceptual view showing an example in which the broadcast receiving system which can realize mobile reception receives a broadcasting signal;

FIG. 29 is a flowchart illustrating an example of receiving the time information from the broadcasting signal;

5

FIG. 30 is a view showing an example of receiving the time information according to a time zone from the broadcasting signal and outputting a current time;

FIG. 31 is a view showing an example of receiving the time information of the time zone from the broadcasting signal and outputting broadcasting information;

FIG. 32 is a view showing an example of the broadcast receiving system; and

FIG. 33 is a flowchart illustrating an example of receiving the broadcasting signal.

DETAILED DESCRIPTION OF THE INVENTION

Reference will now be made in detail to the preferred embodiments of the present invention, examples of which are illustrated in the accompanying drawings. Wherever possible, the same reference numbers will be used throughout the drawings to refer to the same or like parts. In addition, although the terms used in the present invention are selected from generally known and used terms, some of the terms mentioned in the description of the present invention have been selected by the applicant at his or her discretion, the detailed meanings of which are described in relevant parts of the description herein. Furthermore, it is required that the present invention is understood, not simply by the actual terms used but by the meaning of each term lying within.

Among the terms used in the description of the present invention, main service data correspond to data that can be received by a fixed receiving system and may include audio/video (A/V) data. More specifically, the main service data may include A/V data of high definition (HD) or standard definition (SD) levels and may also include diverse data types required for data broadcasting. Also, the known data correspond to data pre-known in accordance with a pre-arranged agreement between the receiving system and the transmitting system. Additionally, in the present invention, mobile service data may include at least one of mobile service data, pedestrian service data, and handheld service data, and are collectively referred to as mobile service data for simplicity. Herein, the mobile service data not only correspond to mobile/pedestrian/handheld service data (M/P/H service data) but may also include any type of service data with mobile or portable characteristics. Therefore, the mobile service data according to the present invention are not limited only to the M/P/H service data.

The above-described mobile service data may correspond to data having information, such as program execution files, stock information, and so on, and may also correspond to A/V data. Most particularly, the mobile service data may correspond to A/V data having lower resolution and lower data rate as compared to the main service data. For example, if an A/V codec that is used for a conventional main service corresponds to a MPEG-2 codec, a MPEG-advanced video coding (AVC) or scalable video coding (SVC) having better image compression efficiency may be used as the A/V codec for the mobile service. Furthermore, any type of data may be transmitted as the mobile service data. For example, transport protocol expert group (TPEG) data for broadcasting real-time transportation information may be serviced as the main service data.

Also, a data service using the mobile service data may include weather forecast services, traffic information services, stock information services, viewer participation quiz programs, real-time polls & surveys, interactive education broadcast programs, gaming services, services providing

6

information on synopsis, character, background music, and filming sites of soap operas or series, services providing information on past match scores and player profiles and achievements, and services providing information on product information and programs classified by service, medium, time, and theme enabling purchase orders to be processed. Herein, the present invention is not limited only to the services mentioned above. In the present invention, the transmitting system provides backward compatibility in the main service data so as to be received by the conventional receiving system. Herein, the main service data and the mobile service data are multiplexed to the same physical channel and then transmitted.

The transmitting system according to the present invention performs additional encoding on the mobile service data and inserts the data already known by the receiving system and transmitting system (i.e., known data), thereby transmitting the processed data. Therefore, when using the transmitting system according to the present invention, the receiving system may receive the mobile service data during a mobile state and may also receive the mobile service data with stability despite various distortion and noise occurring within the channel.

General Description of a Transmitting System

FIG. 1 illustrates a block diagram showing a general structure of a digital broadcast transmitting system according to an embodiment of the present invention. Herein, the digital broadcast transmitting includes a service multiplexer **100** and a transmitter **200**. Herein, the service multiplexer **100** is located in the studio of each broadcast station, and the transmitter **200** is located in a site placed at a predetermined distance from the studio. The transmitter **200** may be located in a plurality of different locations. Also, for example, the plurality of transmitters may share the same frequency. And, in this case, the plurality of transmitters receives the same signal. Accordingly, in the receiving system, a channel equalizer may compensate signal distortion, which is caused by a reflected wave, so as to recover the original signal. In another example, the plurality of transmitters may have different frequencies

A variety of methods may be used for data communication each of the transmitters, which are located in remote positions, and the service multiplexer. For example, an interface standard such as a synchronous serial interface for transport of MPEG-2 data (SMPTE-310M). In the SMPTE-310M interface standard, a constant data rate is decided as an output data rate of the service multiplexer. For example, in case of the 8 VSB mode, the output data rate is 19.39 Mbps, and, in case of the 16 VSB mode, the output data rate is 38.78 Mbps. Furthermore, in the conventional 8 VSB mode transmitting system, a transport stream (TS) packet having a data rate of approximately 19.39 Mbps may be transmitted through a single physical channel. Also, in the transmitting system according to the present invention provided with backward compatibility with the conventional transmitting system, additional encoding is performed on the mobile service data. Thereafter, the additionally encoded mobile service data are multiplexed with the main service data to a TS packet form, which is then transmitted. At this point, the data rate of the multiplexed TS packet is approximately 19.39 Mbps.

At this point, the service multiplexer **100** receives at least one type of mobile service data and program specific information (PSI)/program and system information protocol (PSIP) table data for each mobile service and encapsulates the received data to each transport stream (TS) packet. Also, the service multiplexer **100** receives at least one type of main

service data and PSI/PSIP table data for each main service so as to encapsulate the received data to a TS packet. Subsequently, the TS packets are multiplexed according to a predetermined multiplexing rule and outputs the multiplexed packets to the transmitter **200**.

Service Multiplexer

FIG. 2 illustrates a block diagram showing an example of the service multiplexer. The service multiplexer includes a controller **110** for controlling the overall operations of the service multiplexer, a PSI/PSIP generator **120** for the main service, a PSI/PSIP generator **130** for the mobile service, a null packet generator **140**, a mobile service multiplexer **150**, and a transport multiplexer **160**. The transport multiplexer **160** may include a main service multiplexer **161** and a transport stream (TS) packet multiplexer **162**. Referring to FIG. 2, at least one type of compression encoded main service data and the PSI/PSIP table data generated from the PSI/PSIP generator **120** for the main service are inputted to the main service multiplexer **161** of the transport multiplexer **160**. The main service multiplexer **161** encapsulates each of the inputted main service data and PSI/PSIP table data to MPEG-2 TS packet forms. Then, the MPEG-2 TS packets are multiplexed and outputted to the TS packet multiplexer **162**. Herein, the data packet being outputted from the main service multiplexer **161** will be referred to as a main service data packet for simplicity.

Thereafter, at least one type of the compression encoded mobile service data and the PSI/PSIP table data generated from the PSI/PSIP generator **130** for the mobile service are inputted to the mobile service multiplexer **150**. The mobile service multiplexer **150** encapsulates each of the inputted mobile service data and PSI/PSIP table data to MPEG-2 TS packet forms. Then, the MPEG-2 TS packets are multiplexed and outputted to the TS packet multiplexer **162**. Herein, the data packet being outputted from the mobile service multiplexer **150** will be referred to as a mobile service data packet for simplicity. At this point, the transmitter **200** requires identification information in order to identify and process the main service data packet and the mobile service data packet. Herein, the identification information may use values predecided in accordance with an agreement between the transmitting system and the receiving system, or may be configured of a separate set of data, or may modify predetermined location value within the corresponding data packet. As an example of the present invention, a different packet identifier (PID) may be assigned to identify each of the main service data packet and the mobile service data packet.

In another example, by modifying a synchronization data byte within a header of the mobile service data, the service data packet may be identified by using the synchronization data byte value of the corresponding service data packet. For example, the synchronization byte of the main service data packet directly outputs the value decided by the ISO/IEC13818-1 standard (i.e., 0x47) without any modification. The synchronization byte of the mobile service data packet modifies and outputs the value, thereby identifying the main service data packet and the mobile service data packet. Conversely, the synchronization byte of the main service data packet is modified and outputted, whereas the synchronization byte of the mobile service data packet is directly outputted without being modified, thereby enabling the main service data packet and the mobile service data packet to be identified.

A plurality of methods may be applied in the method of modifying the synchronization byte. For example, each bit of the synchronization byte may be inverted, or only a

portion of the synchronization byte may be inverted. As described above, any type of identification information may be used to identify the main service data packet and the mobile service data packet. Therefore, the scope of the present invention is not limited only to the example set forth in the description of the present invention.

Meanwhile, a transport multiplexer used in the conventional digital broadcasting system may be used as the transport multiplexer **160** according to the present invention. More specifically, in order to multiplex the mobile service data and the main service data and to transmit the multiplexed data, the data rate of the main service is limited to a data rate of $(19.39-K)$ Mbps. Then, K Mbps, which corresponds to the remaining data rate, is assigned as the data rate of the mobile service. Thus, the transport multiplexer which is already being used may be used as it is without any modification. Herein, the transport multiplexer **160** multiplexes the main service data packet being outputted from the main service multiplexer **161** and the mobile service data packet being outputted from the mobile service multiplexer **150**. Thereafter, the transport multiplexer **160** transmits the multiplexed data packets to the transmitter **200**.

However, in some cases, the output data rate of the mobile service multiplexer **150** may not be equal to K Mbps. In this case, the mobile service multiplexer **150** multiplexes and outputs null data packets generated from the null packet generator **140** so that the output data rate can reach K Mbps. More specifically, in order to match the output data rate of the mobile service multiplexer **150** to a constant data rate, the null packet generator **140** generates null data packets, which are then outputted to the mobile service multiplexer **150**. For example, when the service multiplexer **100** assigns K Mbps of the 19.39 Mbps to the mobile service data, and when the remaining $(19.39-K)$ Mbps is, therefore, assigned to the main service data, the data rate of the mobile service data that are multiplexed by the service multiplexer **100** actually becomes lower than K Mbps. This is because, in case of the mobile service data, the pre-processor of the transmitting system performs additional encoding, thereby increasing the amount of data. Eventually, the data rate of the mobile service data, which may be transmitted from the service multiplexer **100**, becomes smaller than K Mbps.

For example, since the pre-processor of the transmitter performs an encoding process on the mobile service data at a coding rate of at least $\frac{1}{2}$, the amount of the data outputted from the pre-processor is increased to more than twice the amount of the data initially inputted to the pre-processor. Therefore, the sum of the data rate of the main service data and the data rate of the mobile service data, both being multiplexed by the service multiplexer **100**, becomes either equal to or smaller than 19.39 Mbps. Therefore, in order to match the data rate of the data that are finally outputted from the service multiplexer **100** to a constant data rate (e.g., 19.39 Mbps), an amount of null data packets corresponding to the amount of lacking data rate is generated from the null packet generator **140** and outputted to the mobile service multiplexer **150**.

Accordingly, the mobile service multiplexer **150** encapsulates each of the mobile service data and the PSI/PSIP table data that are being inputted to a MPEG-2 TS packet form. Then, the above-described TS packets are multiplexed with the null data packets and, then, outputted to the TS packet multiplexer **162**. Thereafter, the TS packet multiplexer **162** multiplexes the main service data packet being outputted from the main service multiplexer **161** and the mobile service data packet being outputted from the mobile

service multiplexer **150** and transmits the multiplexed data packets to the transmitter **200** at a data rate of 19.39 Mbps.

According to an embodiment of the present invention, the mobile service multiplexer **150** receives the null data packets. However, this is merely exemplary and does not limit the scope of the present invention. In other words, according to another embodiment of the present invention, the TS packet multiplexer **162** may receive the null data packets, so as to match the data rate of the finally outputted data to a constant data rate. Herein, the output path and multiplexing rule of the null data packet is controlled by the controller **110**. The controller **110** controls the multiplexing processed performed by the mobile service multiplexer **150**, the main service multiplexer **161** of the transport multiplexer **160**, and the TS packet multiplexer **162**, and also controls the null data packet generation of the null packet generator **140**. At this point, the transmitter **200** discards the null data packets transmitted from the service multiplexer **100** instead of transmitting the null data packets.

Further, in order to allow the transmitter **200** to discard the null data packets transmitted from the service multiplexer **100** instead of transmitting them, identification information for identifying the null data packet is required. Herein, the identification information may use values pre-decided in accordance with an agreement between the transmitting system and the receiving system. For example, the value of the synchronization byte within the header of the null data packet may be modified so as to be used as the identification information. Alternatively, a transport_error_indicator flag may also be used as the identification information.

In the description of the present invention, an example of using the transport_error_indicator flag as the identification information will be given to describe an embodiment of the present invention. In this case, the transport_error_indicator flag of the null data packet is set to '1', and the transport_error_indicator flag of the remaining data packets are reset to '0', so as to identify the null data packet. More specifically, when the null packet generator **140** generates the null data packets, if the transport_error_indicator flag from the header field of the null data packet is set to '1' and then transmitted, the null data packet may be identified and, therefore, be discarded. In the present invention, any type of identification information for identifying the null data packets may be used. Therefore, the scope of the present invention is not limited only to the examples set forth in the description of the present invention.

According to another embodiment of the present invention, a transmission parameter may be included in at least a portion of the null data packet, or at least one table or an operations and maintenance (OM) packet (or OMP) of the PSI/PSIP table for the mobile service. In this case, the transmitter **200** extracts the transmission parameter and outputs the extracted transmission parameter to the corresponding block and also transmits the extracted parameter to the receiving system if required. More specifically, a packet referred to as an OMP is defined for the purpose of operating and managing the transmitting system. For example, the OMP is configured in accordance with the MPEG-2 TS packet format, and the corresponding PID is given the value of 0x1FFA. The OMP is configured of a 4-byte header and a 184-byte payload. Herein, among the 184 bytes, the first byte corresponds to an OM_type field, which indicates the type of the OM packet.

In the present invention, the transmission parameter may be transmitted in the form of an OMP. And, in this case, among the values of the reserved fields within the OM_type field, a pre-arranged value is used, thereby indicating that

the transmission parameter is being transmitted to the transmitter **200** in the form of an OMP. More specifically, the transmitter **200** may find (or identify) the OMP by referring to the PID. Also, by parsing the OM_type field within the OMP, the transmitter **200** can verify whether a transmission parameter is included after the OM_type field of the corresponding packet. The transmission parameter corresponds to supplemental data required for processing mobile service data from the transmitting system and the receiving system.

Herein, the transmission parameter may include data group information, region information within the data group, RS frame information, super frame information, burst information, turbo code information, and RS code information. The burst information may include burst size information, burst period information, and time information to next burst. The burst period signifies the period at which the burst transmitting the same mobile service is repeated. The data group includes a plurality of mobile service data packets, and a plurality of such data groups is gathered (or grouped) to form a burst. A burst section signifies the beginning of a current burst to the beginning of a next burst. Herein, the burst section is classified as a section that includes the data group (also referred to as a burst-on section), and a section that does not include the data group (also referred to as a burst-off section). A burst-on section is configured of a plurality of fields, wherein one field includes one data group.

The transmission parameter may also include information on how signals of a symbol domain are encoded in order to transmit the mobile service data, and multiplexing information on how the main service data and the mobile service data or various types of mobile service data are multiplexed. The information included in the transmission parameter is merely exemplary to facilitate the understanding of the present invention. And, the adding and deleting of the information included in the transmission parameter may be easily modified and changed by anyone skilled in the art. Therefore, the present invention is not limited to the examples proposed in the description set forth herein. Furthermore, the transmission parameters may be provided from the service multiplexer **100** to the transmitter **200**. Alternatively, the transmission parameters may also be set up by an internal controller (not shown) within the transmitter **200** or received from an external source.

Transmitter

FIG. 3 illustrates a block diagram showing an example of the transmitter **200** according to an embodiment of the present invention. Herein, the transmitter **200** includes a demultiplexer **210**, a packet jitter mitigator **220**, a pre-processor **230**, a packet multiplexer **240**, a post-processor **250**, a synchronization (sync) multiplexer **260**, and a transmission unit **270**. Herein, when a data packet is received from the service multiplexer **100**, the demultiplexer **210** should identify whether the received data packet corresponds to a main service data packet, a mobile service data packet, or a null data packet. For example, the demultiplexer **210** uses the PID within the received data packet so as to identify the main service data packet and the mobile service data packet. Then, the demultiplexer **210** uses a transport_error_indicator field to identify the null data packet. The main service data packet identified by the demultiplexer **210** is outputted to the packet jitter mitigator **220**, the mobile service data packet is outputted to the pre-processor **230**, and the null data packet is discarded. If a transmission parameter is included in the null data packet, then the transmission parameter is first extracted and outputted to the corresponding block. Thereafter, the null data packet is discarded.

The pre-processor 230 performs an additional encoding process of the mobile service data included in the service data packet, which is demultiplexed and outputted from the demultiplexer 210. The pre-processor 230 also performs a process of configuring a data group so that the data group may be positioned at a specific place in accordance with the purpose of the data, which are to be transmitted on a transmission frame. This is to enable the mobile service data to respond swiftly and strongly against noise and channel changes. The pre-processor 230 may also refer to the transmission parameter when performing the additional encoding process. Also, the pre-processor 230 groups a plurality of mobile service data packets to configure a data group. Thereafter, known data, mobile service data, RS parity data, and MPEG header are allocated to pre-determined areas within the data group.

Pre-Processor within Transmitter

FIG. 4 illustrates a block diagram showing an example of the pre-processor 230 according to the present invention. The pre-processor 230 includes a data randomizer 301, a RS frame encoder 302, a block processor 303, a group formatter 304, a data deinterleaver 305, a packet formatter 306. The data randomizer 301 within the above-described pre-processor 230 randomizes the mobile service data packet including the mobile service data that is inputted through the demultiplexer 210. Then, the data randomizer 301 outputs the randomized mobile service data packet to the RS frame encoder 302. At this point, since the data randomizer 301 performs the randomizing process on the mobile service data, the randomizing process that is to be performed by the data randomizer 251 of the post-processor 250 on the mobile service data may be omitted. The data randomizer 301 may also discard the synchronization byte within the mobile service data packet and perform the randomizing process. This is an option that may be chosen by the system designer. In the example given in the present invention, the randomizing process is performed without discarding the synchronization byte within the mobile service data packet.

The RS frame encoder 302 groups a plurality of mobile [the synchronization byte within the mobile] service data packets that is randomized and inputted, so as to create a RS frame. Then, the RS frame encoder 302 performs at least one of an error correction encoding process and an error detection encoding process in RS frame units. Accordingly, robustness may be provided to the mobile service data, thereby scattering group error that may occur during changes in a frequency environment, thereby enabling the enhanced data to respond to the frequency environment, which is extremely vulnerable and liable to frequent changes. Also, the RS frame encoder 302 groups a plurality of RS frame so as to create a super frame, thereby performing a row permutation process in super frame units. The row permutation process may also be referred to as a row interleaving process. Hereinafter, the process will be referred to as row permutation for simplicity.

More specifically, when the RS frame encoder 302 performs the process of permuting each row of the super frame in accordance with a pre-determined rule, the position of the rows within the super frame before and after the row permutation process is changed. If the row permutation process is performed by super frame units, and even though the section having a plurality of errors occurring therein becomes very long, and even though the number of errors included in the RS frame, which is to be decoded, exceeds the extent of being able to be corrected, the errors become

dispersed within the entire super frame. Thus, the decoding ability is even more enhanced as compared to a single RS frame.

At this point, as an example of the present invention, RS-encoding is applied for the error correction encoding process, and a cyclic redundancy check (CRC) encoding is applied for the error detection process. When performing the RS-encoding, parity data that are used for the error correction are generated. And, when performing the CRC encoding, CRC data that are used for the error detection are generated. The RS encoding is one of forward error correction (FEC) methods. The FEC corresponds to a technique for compensating errors that occur during the transmission process. The CRC data generated by CRC encoding may be used for indicating whether or not the mobile service data have been damaged by the errors while being transmitted through the channel. In the present invention, a variety of error detection coding methods other than the CRC encoding method may be used, or the error correction coding method may be used to enhance the overall error correction ability of the receiving system. Herein, the RS frame encoder 302 refers to a pre-determined transmission parameter and/or the transmission parameter provided from the service multiplexer 100 so as to perform operations including RS frame configuration, RS encoding, CRC encoding, super frame configuration, and row permutation in super frame units.

Pre-Processor within RS Frame Encoder

FIG. 5(a) to FIG. 5(e) illustrate error correction encoding and error detection encoding processed according to an embodiment of the present invention. More specifically, the RS frame encoder 302 first divides the inputted mobile service data bytes to units of a predetermined length. The predetermined length is decided by the system designer. And, in the example of the present invention, the predetermined length is equal to 187 bytes, and, therefore, the 187-byte unit will be referred to as a packet for simplicity. For example, when the mobile service data that are being inputted, as shown in FIG. 5(a), correspond to a MPEG transport packet stream configured of 188-byte units, the first synchronization byte is removed, as shown in FIG. 5(b), so as to configure a 187-byte unit. Herein, the synchronization byte is removed because each mobile service data packet has the same value.

Herein, the process of removing the synchronization byte may be performed during a randomizing process of the data randomizer 301 in an earlier process. In this case, the process of the removing the synchronization byte by the RS frame encoder 302 may be omitted. Moreover, when adding synchronization bytes from the receiving system, the process may be performed by the data derandomizer instead of the RS frame decoder. Therefore, if a removable fixed byte (e.g., synchronization byte) does not exist within the mobile service data packet that is being inputted to the RS frame encoder 302, or if the mobile service data that are being inputted are not configured in a packet format, the mobile service data that are being inputted are divided into 187-byte units, thereby configuring a packet for each 187-byte unit.

Subsequently, as shown in FIG. 5(c), N number of packets configured of 187 bytes is grouped to configure a RS frame. At this point, the RS frame is configured as a RS frame having the size of N(row)*187(column) bytes, in which 187-byte packets are sequentially inputted in a row direction. In order to simplify the description of the present invention, the RS frame configured as described above will also be referred to as a first RS frame. More specifically, only pure mobile service data are included in the first RS frame, which is the same as the structure configured of 187

N-byte rows. Thereafter, the mobile service data within the RS frame are divided into an equal size. Then, when the divided mobile service data are transmitted in the same order as the input order for configuring the RS frame, and when one or more errors have occurred at a particular point during the transmitting/receiving process, the errors are clustered (or gathered) within the RS frame as well. In this case, the receiving system uses a RS erasure decoding method when performing error correction decoding, thereby enhancing the error correction ability. At this point, the N number of columns within the N number of RS frame includes 187 bytes, as shown in FIG. 5(c).

In this case, a (Nc,Kc)-RS encoding process is performed on each column, so as to generate Nc-Kc(=P) number of parity bytes. Then, the newly generated P number of parity bytes is added after the very last byte of the corresponding column, thereby creating a column of (187+P) bytes. Herein, as shown in FIG. 5(c), Kc is equal to 187 (i.e., Kc=187), and Nc is equal to 187+P (i.e., Nc=187+P). For example, when P is equal to 48, (235,187)-RS encoding process is performed so as to create a column of 235 bytes. When such RS encoding process is performed on all N number of columns, as shown in FIG. 5(c), a RS frame having the size of N(row)*(187+P) (column) bytes may be created, as shown in FIG. 5(d). In order to simplify the description of the present invention, the RS frame having the RS parity inserted therein will be referred to as a second RS frame. More specifically, the second RS frame having the structure of (187+P) rows configured of N bytes may be configured.

As shown in FIG. 5(c) or FIG. 5(d), each row of the RS frame is configured of N bytes. However, depending upon channel conditions between the transmitting system and the receiving system, error may be included in the RS frame. When errors occur as described above, CRC data (or CRC code or CRC checksum) may be used on each row unit in order to verify whether error exists in each row unit. The RS frame encoder 302 may perform CRC encoding on the mobile service data being RS encoded so as to create (or generate) the CRC data. The CRC data being generated by CRC encoding may be used to indicate whether the mobile service data have been damaged while being transmitted through the channel.

The present invention may also use different error detection encoding methods other than the CRC encoding method. Alternatively, the present invention may use the error correction encoding method to enhance the overall error correction ability of the receiving system. FIG. 5(e) illustrates an example of using a 2-byte (i.e., 16-bit) CRC checksum as the CRC data. Herein, a 2 byte CRC checksum is generated for N number of bytes of each row, thereby adding the 2-byte CRC checksum at the end of the N number of bytes. Thus, each row is expanded to (N+2) number of bytes. Equation 1 below corresponds to an exemplary equation for generating a 2-byte CRC checksum for each row being configured of N number of bytes.

$$g(x)=x^{16}+x^{12}+x^5+1 \quad \text{Equation 1}$$

The process of adding a 2-byte checksum in each row is only exemplary. Therefore, the present invention is not limited only to the example proposed in the description set forth herein. In order to simplify the understanding of the present invention, the RS frame having the RS parity and CRC checksum added therein will hereinafter be referred to as a third RS frame. More specifically, the third RS frame corresponds to (187+P) number of rows each configured of (N+2) number of bytes. As described above, when the process of RS encoding and CRC encoding are completed,

the (N*187)-byte RS frame is expanded to a (N+2)*(187+P)-byte RS frame. Furthermore, the RS frame that is expanded, as shown in FIG. 5(e), is inputted to the block processor 303.

As described above, the mobile service data encoded by the RS frame encoder 302 are inputted to the block processor 303. The block processor 303 then encodes the inputted mobile service data at a coding rate of G/H (wherein, G is smaller than H (i.e., G<H)) and then outputted to the group formatter 304. More specifically, the block processor 303 divides the mobile service data being inputted in byte units into bit units. Then, the G number of bits is encoded to H number of bits. Thereafter, the encoded bits are converted back to byte units and then outputted. For example, if 1 bit of the input data is coded to 2 bits and outputted, then G is equal to 1 and H is equal to 2 (i.e., G=1 and H=2). Alternatively, if 1 bit of the input data is coded to 4 bits and outputted, then G is equal to 1 and H is equal to 4 (i.e., G=1 and H=4). Hereinafter, the former coding rate will be referred to as a coding rate of 1/2 (1/2-rate coding), and the latter coding rate will be referred to as a coding rate of 1/4 (1/4-rate coding), for simplicity.

Herein, when using the 1/4 coding rate, the coding efficiency is greater than when using the 1/2 coding rate, and may, therefore, provide greater and enhanced error correction ability. For such reason, when it is assumed that the data encoded at a 1/4 coding rate in the group formatter 304, which is located near the end portion of the system, are allocated to an area in which the receiving performance may be deteriorated, and that the data encoded at a 1/2 coding rate are allocated to an area having excellent receiving performance, the difference in performance may be reduced. At this point, the block processor 303 may also receive signaling information including transmission parameters. Herein, the signaling information may also be processed with either 1/2-rate coding or 1/4-rate coding as in the step of processing mobile service data. Thereafter, the signaling information is also considered the same as the mobile service data and processed accordingly.

Meanwhile, the group formatter inserts mobile service data that are outputted from the block processor 303 in corresponding areas within a data group, which is configured in accordance with a pre-defined rule. Also, with respect to the data deinterleaving process, each place holder or known data (or known data place holders) are also inserted in corresponding areas within the data group. At this point, the data group may be divided into at least one hierarchical area. Herein, the type of mobile service data being inserted in each area may vary depending upon the characteristics of each hierarchical area. Additionally, each area may, for example, be divided based upon the receiving performance within the data group. Furthermore, one data group may be configured to include a set of field synchronization data.

In an example given in the present invention, a data group is divided into A, B, and C regions in a data configuration prior to data deinterleaving. At this point, the group formatter 304 allocates the mobile service data, which are inputted after being RS encoded and block encoded, to each of the corresponding regions by referring to the transmission parameter. FIG. 6A illustrates an alignment of data after being data interleaved and identified, and FIG. 6B illustrates an alignment of data before being data interleaved and identified. More specifically, a data structure identical to that shown in FIG. 6A is transmitted to a receiving system. Also,

the data group configured to have the same structure as the data structure shown in FIG. 6A is inputted to the data deinterleaver 305.

As described above, FIG. 6A illustrates a data structure prior to data deinterleaving that is divided into 3 regions, such as region A, region B, and region C. Also, in the present invention, each of the regions A to C is further divided into a plurality of regions. Referring to FIG. 6A, region A is divided into 5 regions (A1 to A5), region B is divided into 2 regions (B1 and B2), and region C is divided into 3 regions (C1 to C3). Herein, regions A to C are identified as regions having similar receiving performances within the data group. Herein, the type of mobile service data, which are inputted, may also vary depending upon the characteristic of each region.

In the example of the present invention, the data structure is divided into regions A to C based upon the level of interference of the main service data. Herein, the data group is divided into a plurality of regions to be used for different purposes. More specifically, a region of the main service data having no interference or a very low interference level may be considered to have a more resistant (or stronger) receiving performance as compared to regions having higher interference levels. Additionally, when using a system inserting and transmitting known data in the data group, and when consecutively long known data are to be periodically inserted in the mobile service data, the known data having a predetermined length may be periodically inserted in the region having no interference from the main service data (e.g., region A). However, due to interference from the main service data, it is difficult to periodically insert known data and also to insert consecutively long known data to a region having interference from the main service data (e.g., region B and region C).

Hereinafter, examples of allocating data to region A (A1 to A5), region B (B1 and B2), and region C (C1 to C3) will now be described in detail with reference to FIG. 6A. The data group size, the number of hierarchically divided regions within the data group and the size of each region, and the number of mobile service data bytes that can be inserted in each hierarchically divided region of FIG. 6A are merely examples given to facilitate the understanding of the present invention. Herein, the group formatter 304 creates a data group including places in which field synchronization data bytes are to be inserted, so as to create the data group that will hereinafter be described in detail.

More specifically, region A is a region within the data group in which a long known data sequence may be periodically inserted, and in which includes regions wherein the main service data are not mixed (e.g., A1 to A5). Also, region A includes a region (e.g., A1) located between a field synchronization region and the region in which the first known data sequence is to be inserted. The field synchronization region has the length of one segment (i.e., 832 symbols) existing in an ATSC system.

For example, referring to FIG. 6A, 2428 bytes of the mobile service data may be inserted in region A1, 2580 bytes may be inserted in region A2, 2772 bytes may be inserted in region A3, 2472 bytes may be inserted in region A4, and 2772 bytes may be inserted in region A5. Herein, trellis initialization data or known data, MPEG header, and RS parity are not included in the mobile service data. As described above, when region A includes a known data sequence at both ends, the receiving system uses channel information that can obtain known data or field synchronization data, so as to perform equalization, thereby providing enforced equalization performance.

Also, region B includes a region located within 8 segments at the beginning of a field synchronization region within the data group (chronologically placed before region A1) (e.g., region B1), and a region located within 8 segments behind the very last known data sequence which is inserted in the data group (e.g., region B2). For example, 930 bytes of the mobile service data may be inserted in the region B1, and 1350 bytes may be inserted in region B2. Similarly, trellis initialization data or known data, MPEG header, and RS parity are not included in the mobile service data. In case of region B, the receiving system may perform equalization by using channel information obtained from the field synchronization region. Alternatively, the receiving system may also perform equalization by using channel information that may be obtained from the last known data sequence, thereby enabling the system to respond to the channel changes.

Region C includes a region located within 30 segments including and preceding the 9th segment of the field synchronization region (chronologically located before region A) (e.g., region C1), a region located within 12 segments including and following the 9th segment of the very last known data sequence within the data group (chronologically located after region A) (e.g., region C2), and a region located in 32 segments after the region C2 (e.g., region C3). For example, 1272 bytes of the mobile service data may be inserted in the region C1, 1560 bytes may be inserted in region C2, and 1312 bytes may be inserted in region C3. Similarly, trellis initialization data or known data, MPEG header, and RS parity are not included in the mobile service data. Herein, region C (e.g., region C1) is located chronologically earlier than (or before) region A.

Since region C (e.g., region C1) is located further apart from the field synchronization region which corresponds to the closest known data region, the receiving system may use the channel information obtained from the field synchronization data when performing channel equalization. Alternatively, the receiving system may also use the most recent channel information of a previous data group. Furthermore, in region C (e.g., region C2 and region C3) located before region A, the receiving system may use the channel information obtained from the last known data sequence to perform equalization. However, when the channels are subject to fast and frequent changes, the equalization may not be performed perfectly. Therefore, the equalization performance of region C may be deteriorated as compared to that of region B.

When it is assumed that the data group is allocated with a plurality of hierarchically divided regions, as described above, the block processor 303 may encode the mobile service data, which are to be inserted to each region based upon the characteristic of each hierarchical region, at a different coding rate. For example, the block processor 303 may encode the mobile service data, which are to be inserted in regions A1 to A5 of region A, at a coding rate of $\frac{1}{2}$. Then, the group formatter 304 may insert the $\frac{1}{2}$ -rate encoded mobile service data to regions A1 to A5.

The block processor 303 may encode the mobile service data, which are to be inserted in regions B1 and B2 of region B, at a coding rate of $\frac{1}{4}$ having higher error correction ability as compared to the $\frac{1}{2}$ -coding rate. Then, the group formatter 304 inserts the $\frac{1}{4}$ -rate coded mobile service data in region B1 and region B2. Furthermore, the block processor 303 may encode the mobile service data, which are to be inserted in regions C1 to C3 of region C, at a coding rate of $\frac{1}{4}$ or a coding rate having higher error correction ability than the $\frac{1}{4}$ -coding rate. Then, the group formatter 304 may either

insert the encoded mobile service data to regions C1 to C3, as described above, or leave the data in a reserved region for future usage.

In addition, the group formatter **304** also inserts supplemental data, such as signaling information that notifies the overall transmission information, other than the mobile service data in the data group. Also, apart from the encoded mobile service data outputted from the block processor **303**, the group formatter **304** also inserts MPEG header place holders, non-systematic RS parity place holders, main service data place holders, which are related to data deinterleaving in a later process, as shown in FIG. 6A. Herein, the main service data place holders are inserted because the mobile service data bytes and the main service data bytes are alternately mixed with one another in regions B and C based upon the input of the data deinterleaver, as shown in FIG. 6A. For example, based upon the data outputted after data deinterleaving, the place holder for the MPEG header may be allocated at the very beginning of each packet.

Furthermore, the group formatter **304** either inserts known data generated in accordance with a pre-determined method or inserts known data place holders for inserting the known data in a later process. Additionally, place holders for initializing the trellis encoding module **256** are also inserted in the corresponding regions. For example, the initialization data place holders may be inserted in the beginning of the known data sequence. Herein, the size of the mobile service data that can be inserted in a data group may vary in accordance with the sizes of the trellis initialization place holders or known data (or known data place holders), MPEG header place holders, and RS parity place holders.

The output of the group formatter **304** is inputted to the data deinterleaver **305**. And, the data deinterleaver **305** deinterleaves data by performing an inverse process of the data interleaver on the data and place holders within the data group, which are then outputted to the packet formatter **306**. More specifically, when the data and place holders within the data group configured, as shown in FIG. 6A, are deinterleaved by the data deinterleaver **305**, the data group being outputted to the packet formatter **306** is configured to have the structure shown in FIG. 6B.

The packet formatter **306** removes the main service data place holders and the RS parity place holders that were allocated for the deinterleaving process from the deinterleaved data being inputted. Then, the packet formatter **306** groups the remaining portion and replaces the 4-byte MPEG header place holder with an MPEG header having a null packet PID (or an unused PID from the main service data packet). Also, when the group formatter **304** inserts known data place holders, the packet formatter **306** may insert actual known data in the known data place holders, or may directly output the known data place holders without any modification in order to make replacement insertion in a later process. Thereafter, the packet formatter **306** identifies the data within the packet-formatted data group, as described above, as a 188-byte unit mobile service data packet (i.e., MPEG TS packet), which is then provided to the packet multiplexer **240**.

The packet multiplexer **240** multiplexes the mobile service data packet outputted from the pre-processor **230** and the main service data packet outputted from the packet jitter mitigator **220** in accordance with a pre-defined multiplexing method. Then, the packet multiplexer **240** outputs the multiplexed data packets to the data randomizer **251** of the postprocessor **250**. Herein, the multiplexing method may vary in accordance with various variables of the system design. One of the multiplexing methods of the packet

formatter **240** consists of providing a burst section along a time axis, and, then, transmitting a plurality of data groups during a burst-on section within the burst section, and transmitting only the main service data during the burst-off section within the burst section. Herein, the burst section indicates the section starting from the beginning of the current burst until the beginning of the next burst.

At this point, the main service data may be transmitted during the burst-on section. The packet multiplexer **240** refers to the transmission parameter, such as information on the burst size or the burst period, so as to be informed of the number of data groups and the period of the data groups included in a single burst. Herein, the mobile service data and the main service data may co-exist in the burst-on section, and only the main service data may exist in the burst-off section. Therefore, a main data service section transmitting the main service data may exist in both burst-on and burst-off sections. At this point, the main data service section within the burst-on section and the number of main data service packets included in the burst-off section may either be different from one another or be the same.

When the mobile service data are transmitted in a burst structure, in the receiving system receiving only the mobile service data turns the power on only during the burst section, thereby receiving the corresponding data. Alternatively, in the section transmitting only the main service data, the power is turned off so that the main service data are not received in this section. Thus, the power consumption of the receiving system may be reduced.

Detailed Embodiments of the RS Frame Structure and Packet Multiplexing

Hereinafter, detailed embodiments of the pre-processor **230** and the packet multiplexer **240** will now be described. According to an embodiment of the present invention, the N value corresponding to the length of a row, which is included in the RS frame that is configured by the RS frame encoder **302**, is set to 538. Accordingly, the RS frame encoder **302** receives 538 transport stream (TS) packets so as to configure a first RS frame having the size of 538*187 bytes. Thereafter, as described above, the first RS frame is processed with a (235,187)-RS encoding process so as to configure a second RS frame having the size of 538*235 bytes. Finally, the second RS frame is processed with generating a 16-bit checksum so as to configure a third RS frame having the sizes of 540*235.

Meanwhile, as shown in FIG. 6A, the sum of the number of bytes of regions A1 to A5 of region A, in which 1/2-rate encoded mobile service data are to be inserted, among the plurality of regions within the data group is equal to 13024 bytes (=2428+2580+2772+2472+2772 bytes). Herein, the number of byte prior to performing the 1/2-rate encoding process is equal to 6512 (=13024/2). On the other hand, the sum of the number of bytes of regions B1 and B2 of region B, in which 1/4-rate encoded mobile service data are to be inserted, among the plurality of regions within the data group is equal to 2280 bytes (=930+1350 bytes). Herein, the number of byte prior to performing the 1/4-rate encoding process is equal to 570 (=2280/4).

In other words, when 7082bytes of mobile service data are inputted to the block processor **303**, 6512 byte are expanded to 13024 bytes by being 1/2-rate encoded, and 570 bytes are expanded to 2280 bytes by being 1/4-rate encoded. Thereafter, the block processor **303** inserts the mobile service data expanded to 13024 bytes in regions A1 to A5 of region A and, also, inserts the mobile service data expanded to 2280 bytes in regions B1 and B2 of region B. Herein, the 7082 bytes of mobile service data being inputted to the block

processor **303** may be divided into an output of the RS frame encoder **302** and signaling information. In the present invention, among the 7082 bytes of mobile service data, 7050 bytes correspond to the output of the RS frame encoder **302**, and the remaining 32 bytes correspond to the signaling information data. Then, $\frac{1}{2}$ -rate encoding or $\frac{1}{4}$ -rate encoding is performed on the corresponding data bytes.

Meanwhile, a RS frame being processed with RS encoding and CRC encoding from the RS frame encoder **302** is configured of 540×235 bytes, in other words, 126900 bytes. The 126900 bytes are divided by 7050-byte units along the time axis, so as to produce 7050-byte units. Thereafter, a 32-byte unit of signaling information data is added to the 7050-byte unit mobile service data being outputted from the RS frame encoder **302**. Subsequently, the RS frame encoder **302** performs $\frac{1}{2}$ -rate encoding or $\frac{1}{4}$ -rate encoding on the corresponding data bytes, which are then outputted to the group formatter **304**. Accordingly, the group formatter **304** inserts the $\frac{1}{2}$ -rate encoded data in region A and the $\frac{1}{4}$ -rate encoded data in region B.

The process of deciding an N value that is required for configuring the RS frame from the RS frame encoder **302** will now be described in detail. More specifically, the size of the final RS frame (i.e., the third RS frame), which is RS encoded and CRC encoded from the RS frame encoder **302**, which corresponds to $(N+2) \times 235$ bytes should be allocated to X number of groups, wherein X is an integer. Herein, in a single data group, 7050 data bytes prior to being encoded are allocated. Therefore, if the $(N+2) \times 235$ bytes are set to be the exact multiple of 7050 ($=30 \times 235$), the output data of the RS frame encoder **302** may be efficiently allocated to the data group. According to an embodiment of the present invention, the value of N is decided so that $(N+2)$ becomes a multiple of 30. For example, in the present invention, N is equal to 538, and $(N+2) (=540)$ divided by 30 is equal to 18. This indicates that the mobile service data within one RS frame are processed with either $\frac{1}{2}$ -rate encoding or $\frac{1}{4}$ -rate encoding. The encoded mobile service data are then allocated to 18 data groups.

FIG. 7 illustrates a process of dividing the RS frame according to the present invention. More specifically, the RS frame having the size of $(N+2) \times 235$ is divided into 30×235 byte blocks. Then, the divided blocks are mapped to a single group. In other words, the data of a block having the size of 30×235 bytes are processed with one of a $\frac{1}{2}$ -rate encoding process and a $\frac{1}{4}$ -rate encoding process and are, then, inserted in a data group. Thereafter, the data group having corresponding data and place holders inserted in each hierarchical region divided by the group formatter **304** passes through the data deinterleaver **305** and the packet formatter **306** so as to be inputted to the packet multiplexer **240**.

FIG. 8 illustrates exemplary operations of a packet multiplexer for transmitting the data group according to the present invention. More specifically, the packet multiplexer **240** multiplexes a field including a data group, in which the mobile service data and main service data are mixed with one another, and a field including only the main service data. Thereafter, the packet multiplexer **240** outputs the multiplexed fields to the data randomizer **251**. At this point, in order to transmit the RS frame having the size of 540×235 bytes, 18 data groups should be transmitted. Herein, each data group includes field synchronization data, as shown in FIG. 6A. Therefore, the 18 data groups are transmitted during 18 field sections, and the section during which the 18 data groups are being transmitted corresponds to the burst-on section.

In each field within the burst-on section, a data group including field synchronization data is multiplexed with main service data, which are then outputted. For example, in the embodiment of the present invention, in each field within the burst-on section, a data group having the size of 118 segments is multiplexed with a set of main service data having the size of 194 segments. Referring to FIG. 8, during the burst-on section (i.e., during the 18 field sections), a field including 18 data groups is transmitted. Then, during the burst-off section that follows (i.e., during the 12 field sections), a field consisting only of the main service data is transmitted. Subsequently, during a subsequent burst-on section, 18 fields including 18 data groups are transmitted. And, during the following burst-off section, 12 fields consisting only of the main service data are transmitted.

Furthermore, in the present invention, the same type of data service may be provided in the first burst-on section including the first 18 data groups and in the second burst-on section including the next 18 data groups. Alternatively, different types of data service may be provided in each burst-on section. For example, when it is assumed that different data service types are provided to each of the first burst-on section and the second burst-on section, and that the receiving system wishes to receive only one type of data service, the receiving system turns the power on only during the corresponding burst-on section including the desired data service type so as to receive the corresponding 18 data fields. Then, the receiving system turns the power off during the remaining 42 field sections so as to prevent other data service types from being received. Thus, the amount of power consumption of the receiving system may be reduced. In addition, the receiving system according to the present invention is advantageous in that one RS frame may be configured from the 18 data groups that are received during a single burst-on section.

According to the present invention, the number of data groups included in a burst-on section may vary based upon the size of the RS frame, and the size of the RS frame varies in accordance with the value N. More specifically, by adjusting the value N, the number of data groups within the burst section may be adjusted. Herein, in an example of the present invention, the $(235,187)$ -RS encoding process adjusts the value N during a fixed state. Furthermore, the size of the mobile service data that can be inserted in the data group may vary based upon the sizes of the trellis initialization data or known data, the MPEG header, and the RS parity, which are inserted in the corresponding data group.

Meanwhile, since a data group including mobile service data in-between the data bytes of the main service data during the packet multiplexing process, the shifting of the chronological position (or place) of the main service data packet becomes relative. Also, a system object decoder (i.e., MPEG decoder) for processing the main service data of the receiving system, receives and decodes only the main service data and recognizes the mobile service data packet as a null data packet. Therefore, when the system object decoder of the receiving system receives a main service data packet that is multiplexed with the data group, a packet jitter occurs.

At this point, since a multiple-level buffer for the video data exists in the system object decoder and the size of the buffer is relatively large, the packet jitter generated from the packet multiplexer **240** does not cause any serious problem in case of the video data. However, since the size of the buffer for the audio data is relatively small, the packet jitter may cause considerable problem. More specifically, due to the packet jitter, an overflow or underflow may occur in the buffer for the main service data of the receiving system (e.g.,

the buffer for the audio data). Therefore, the packet jitter mitigator **220** re-adjusts the relative position of the main service data packet so that the overflow or underflow does not occur in the system object decoder.

In the present invention, examples of repositioning places for the audio data packets within the main service data in order to minimize the influence on the operations of the audio buffer will be described in detail. The packet jitter mitigator **220** repositions the audio data packets in the main service data section so that the audio data packets of the main service data can be as equally and uniformly aligned and positioned as possible. The standard for repositioning the audio data packets in the main service data performed by the packet jitter mitigator **220** will now be described. Herein, it is assumed that the packet jitter mitigator **220** knows the same multiplexing information as that of the packet multiplexer **240**, which is placed further behind the packet jitter mitigator **220**.

Firstly, if one audio data packet exists in the main service data section (e.g., the main service data section positioned between two data groups) within the burst-on section, the audio data packet is positioned at the very beginning of the main service data section. Alternatively, if two audio data packets exist in the corresponding data section, one audio data packet is positioned at the very beginning and the other audio data packet is positioned at the very end of the main service data section. Further, if more than three audio data packets exist, one audio data packet is positioned at the very beginning of the main service data section, another is positioned at the very end of the main service data section, and the remaining audio data packets are equally positioned between the first and last audio data packets. Secondly, during the main service data section placed immediately before the beginning of a burst-on section (i.e., during a burst-off section), the audio data packet is placed at the very end of the corresponding section.

Thirdly, during a main service data section within the burst-off section after the burst-on section, the audio data packet is positioned at the very end of the main service data section. Finally, the data packets other than audio data packets are positioned in accordance with the inputted order in vacant spaces (i.e., spaces that are not designated for the audio data packets). Meanwhile, when the positions of the main service data packets are relatively re-adjusted, associated program clock reference (PCR) values may also be modified accordingly. The PCR value corresponds to a time reference value for synchronizing the time of the MPEG decoder. Herein, the PCR value is inserted in a specific region of a TS packet and then transmitted.

In the example of the present invention, the packet jitter mitigator **220** also performs the operation of modifying the PCR value. The output of the packet jitter mitigator **220** is inputted to the packet multiplexer **240**. As described above, the packet multiplexer **240** multiplexes the main service data packet outputted from the packet jitter mitigator **220** with the mobile service data packet outputted from the pre-processor **230** into a burst structure in accordance with a pre-determined multiplexing rule. Then, the packet multiplexer **240** outputs the multiplexed data packets to the data randomizer **251** of the post-processor **250**.

If the inputted data correspond to the main service data packet, the data randomizer **251** performs the same randomizing process as that of the conventional randomizer. More specifically, the synchronization byte within the main service data packet is deleted. Then, the remaining 187 data bytes are randomized by using a pseudo random byte

generated from the data randomizer **251**. Thereafter, the randomized data are outputted to the RS encoder/non-systematic RS encoder **252**.

On the other hand, if the inputted data correspond to the mobile service data packet, the data randomizer **251** may randomize only a portion of the data packet. For example, if it is assumed that a randomizing process has already been performed in advance on the mobile service data packet by the pre-processor **230**, the data randomizer **251** deletes the synchronization byte from the 4-byte MPEG header included in the mobile service data packet and, then, performs the randomizing process only on the remaining 3 data bytes of the MPEG header. Thereafter, the randomized data bytes are outputted to the RS encoder/non-systematic RS encoder **252**. More specifically, the randomizing process is not performed on the remaining portion of the mobile service data excluding the MPEG header. In other words, the remaining portion of the mobile service data packet is directly outputted to the RS encoder/non-systematic RS encoder **252** without being randomized. Also, the data randomizer **251** may or may not perform a randomizing process on the known data (or known data place holders) and the initialization data place holders included in the mobile service data packet.

The RS encoder/non-systematic RS encoder **252** performs an RS encoding process on the data being randomized by the data randomizer **251** or on the data bypassing the data randomizer **251**, so as to add 20 bytes of RS parity data. Thereafter, the processed data are outputted to the data interleaver **253**. Herein, if the inputted data correspond to the main service data packet, the RS encoder/non-systematic RS encoder **252** performs the same systematic RS encoding process as that of the conventional broadcasting system, thereby adding the 20-byte RS parity data at the end of the 187-byte data. Alternatively, if the inputted data correspond to the mobile service data packet, the RS encoder/non-systematic RS encoder **252** performs a non-systematic RS encoding process. At this point, the 20-byte RS parity data obtained from the non-systematic RS encoding process are inserted in a pre-decided parity byte place within the mobile service data packet.

The data interleaver **253** corresponds to a byte unit convolutional interleaver. The output of the data interleaver **253** is inputted to the parity replacer **254** and to the non-systematic RS encoder **255**. Meanwhile, a process of initializing a memory within the trellis encoding module **256** is primarily required in order to decide the output data of the trellis encoding module **256**, which is located after the parity replacer **254**, as the known data pre-defined according to an agreement between the receiving system and the transmitting system. More specifically, the memory of the trellis encoding module **256** should first be initialized before the received known data sequence is trellis-encoded. At this point, the beginning portion of the known data sequence that is received corresponds to the initialization data place holder and not to the actual known data. Herein, the initialization data place holder has been included in the data by the group formatter within the pre-processor **230** in an earlier process. Therefore, the process of generating initialization data and replacing the initialization data place holder of the corresponding memory with the generated initialization data are required to be performed immediately before the inputted known data sequence is trellis-encoded.

Additionally, a value of the trellis memory initialization data is decided and generated based upon a memory status of the trellis encoding module **256**. Further, due to the newly replaced initialization data, a process of newly calculating

the RS parity and replacing the RS parity, which is outputted from the data interleaver **253**, with the newly calculated RS parity is required. Therefore, the non-systematic RS encoder **255** receives the mobile service data packet including the initialization data place holders, which are to be replaced with the actual initialization data, from the data interleaver **253** and also receives the initialization data from the trellis encoding module **256**.

Among the inputted mobile service data packet, the initialization data place holders are replaced with the initialization data, and the RS parity data that are added to the mobile service data packet are removed and processed with non-systematic RS encoding. Thereafter, the new RS parity obtained by performing the non-systematic RS encoding process is outputted to the parity replacer **255**. Accordingly, the parity replacer **255** selects the output of the data interleaver **253** as the data within the mobile service data packet, and the parity replacer **255** selects the output of the non-systematic RS encoder **255** as the RS parity. The selected data are then outputted to the trellis encoding module **256**.

Meanwhile, if the main service data packet is inputted or if the mobile service data packet, which does not include any initialization data place holders that are to be replaced, is inputted, the parity replacer **254** selects the data and RS parity that are outputted from the data interleaver **253**. Then, the parity replacer **254** directly outputs the selected data to the trellis encoding module **256** without any modification. The trellis encoding module **256** converts the byte-unit data to symbol units and performs a 12-way interleaving process so as to trellis-encode the received data. Thereafter, the processed data are outputted to the synchronization multiplexer **260**.

The synchronization multiplexer **260** inserts a field synchronization signal and a segment synchronization signal to the data outputted from the trellis encoding module **256** and, then, outputs the processed data to the pilot inserter **271** of the transmission unit **270**. Herein, the data having a pilot inserted therein by the pilot inserter **271** are modulated by the modulator **272** in accordance with a pre-determined modulating method (e.g., a VSB method). Thereafter, the modulated data are transmitted to each receiving system through the radio frequency (RF) up-converter **273**.

Block Processor

FIG. 9 illustrates a block diagram showing a structure of a block processor according to the present invention. Herein, the block processor includes a byte-bit converter **401**, a symbol encoder **402**, a symbol interleaver **403**, and a symbol-byte converter **404**. The byte-bit converter **401** divides the mobile service data bytes that are inputted from the RS frame encoder **112** into bits, which are then outputted to the symbol encoder **402**. The byte-bit converter **401** may also receive signaling information including transmission parameters. The signaling information data bytes are also divided into bits so as to be outputted to the symbol encoder **402**. Herein, the signaling information including transmission parameters may be processed with the same data processing step as that of the mobile service data. More specifically, the signaling information may be inputted to the block processor **303** by passing through the data randomizer **301** and the RS frame encoder **302**. Alternatively, the signaling information may also be directly outputted to the block processor **303** without passing through the data randomizer **301** and the RS frame encoder **302**.

The symbol encoder **402** corresponds to a G/H-rate encoder encoding the inputted data from G bits to H bits and outputting the data encoded at the coding rate of G/H. According to the embodiment of the present invention, it is

assumed that the symbol encoder **402** performs either a coding rate of $\frac{1}{2}$ (also referred to as a $\frac{1}{2}$ -rate encoding process) or an encoding process at a coding rate of $\frac{1}{4}$ (also referred to as $\frac{1}{4}$ -rate encoding process). The symbol encoder **402** performs one of $\frac{1}{2}$ -rate encoding and $\frac{1}{4}$ -rate encoding on the inputted mobile service data and signaling information. Thereafter, the signaling information is also recognized as the mobile service data and processed accordingly.

In case of performing the $\frac{1}{2}$ -rate coding process, the symbol encoder **402** receives 1 bit and encodes the received 1 bit to 2 bits (i.e., 1 symbol). Then, the symbol encoder **402** outputs the processed 2 bits (or 1 symbol). On the other hand, in case of performing the $\frac{1}{4}$ -rate encoding process, the symbol encoder **402** receives 1 bit and encodes the received 1 bit to 4 bits (i.e., 2 symbols). Then, the symbol encoder **402** outputs the processed 4 bits (or 2 symbols).

FIG. 10 illustrates a detailed block diagram of the symbol encoder **402** shown in FIG. 9. The symbol encoder **402** includes two delay units **501** and **503** and three adders **502**, **504**, and **505**. Herein, the symbol encoder **402** encodes an input data bit U and outputs the coded bit U to 4 bits (u0 to u4). At this point, the data bit U is directly outputted as uppermost bit u0 and simultaneously encoded as lower bit u1u2u3 and then outputted. More specifically, the input data bit U is directly outputted as the uppermost bit u0 and simultaneously outputted to the first and third adders **502** and **505**. The first adder **502** adds the input data bit U and the output bit of the first delay unit **501** and, then, outputs the added bit to the second delay unit **503**. Then, the data bit delayed by a predetermined time (e.g., by 1 clock) in the second delay unit **503** is outputted as lower bit u1 and simultaneously fed-back to the first delay unit **501**. The first delay unit **501** delays the data bit fed-back from the second delay unit **503** by a pre-determined time (e.g., by 1 clock). Then, the first delay unit **501** outputs the delayed data bit to the first adder **502** and the second adder **504**. The second adder **504** adds the data bits outputted from the first and second delay units **501** and **503** as a lower bit u2. The third adder **505** adds the input data bit U and the output of the second delay unit **503** and outputs the added data bit as a lower bit u3.

At this point, if the input data bit U corresponds to data encoded at a $\frac{1}{2}$ -coding rate, the symbol encoder **402** configures a symbol with ulu0 bits from the 4 output bits u0u1u2u3. Then, the symbol encoder **402** outputs the newly configured symbol. Alternatively, if the input data bit U corresponds to data encoded at a $\frac{1}{4}$ -coding rate, the symbol encoder **402** configures and outputs a symbol with bits ulu0 and, then, configures and outputs another symbol with bits u2u3. According to another embodiment of the present invention, if the input data bit U corresponds to data encoded at a $\frac{1}{4}$ -coding rate, the symbol encoder **402** may also configure and output a symbol with bits ulu0, and then repeat the process once again and output the corresponding bits. According to yet another embodiment of the present invention, the symbol encoder outputs all four output bits U u0u1u2u3. Then, when using the $\frac{1}{2}$ -coding rate, the symbol interleaver **403** located behind the symbol encoder **402** selects only the symbol configured of bits ulu0 from the four output bits u0u1u2u3. Alternatively, when using the $\frac{1}{4}$ -coding rate, the symbol interleaver **403** may select the symbol configured of bits ulu0 and then select another symbol configured of bits u2u3. According to another embodiment, when using the $\frac{1}{4}$ -coding rate, the symbol interleaver **403** may repeatedly select the symbol configured of bits u1u0.

The output of the symbol encoder 402 is inputted to the symbol interleaver 403. Then, the symbol interleaver 403 performs block interleaving in symbol units on the data outputted from the symbol encoder 402. Any interleaver performing structural rearrangement (or realignment) may be applied as the symbol interleaver 403 of the block processor.

However, in the present invention, a variable length symbol interleaver that can be applied even when a plurality of lengths is provided for the symbol, so that its order may be rearranged, may also be used.

FIG. 11 illustrates a symbol interleaver according to an embodiment of the present invention. Herein, the symbol interleaver according to the embodiment of the present invention corresponds to a variable length symbol interleaver that may be applied even when a plurality of lengths is provided for the symbol, so that its order may be rearranged. Particularly, FIG. 11 illustrates an example of the symbol interleaver when $K=6$ and $L=8$. Herein, K indicates a number of symbols that are outputted for symbol interleaving from the symbol encoder 402. And, L represents a number of symbols that are actually interleaved by the symbol interleaver 403.

In the present invention, the symbol interleaver 403 should satisfy the conditions of (wherein n is an integer) and of If there is a difference in value between K and L , (LK) number of null (or dummy) symbols is added, thereby creating an interleaving pattern. Therefore, K becomes a block size of the actual symbols that are inputted to the symbol interleaver 403 in order to be interleaved. L becomes an interleaving unit when the interleaving process is performed by an interleaving pattern created from the symbol interleaver 403. The example of what is described above is illustrated in FIG. 11.

More specifically, FIG. 11(a) to FIG. 11(c) illustrate a variable length interleaving process of a symbol interleaver shown in FIG. 9. The number of symbols outputted from the symbol encoder 402 in order to be interleaved is equal to 6 (i.e., $K=6$). In other words, 6 symbols are outputted from the symbol encoder 402 in order to be interleaved. And, the actual interleaving unit (L) is equal to 8 symbols. Therefore, as shown in FIG. 11(a), 2 symbols are added to the null (or dummy) symbol, thereby creating the interleaving pattern. Equation 2 shown below described the process of sequentially receiving K number of symbols, the order of which is to be rearranged, and obtaining an L value satisfying the conditions of (wherein n is an integer) and of, thereby creating the interleaving so as to realign (or rearrange) the symbol order.

In relation to all places, wherein $0 \leq i \leq L-1$.

$$P(i) = \{S \times i \times (i+1) / 2\} \bmod L \quad \text{Equation 2}$$

Herein, $L \geq k$, $L=2^n$, and n and S are integers. Referring to FIG. 11, it is assumed that S is equal to 89. and that L is equal to 8, and FIG. 11 illustrates the created interleaving pattern and an example of the interleaving process. As shown in FIG. 11(b), the order of K number of input symbols and $(L-K)$ number of null symbols is rearranged by using the above-mentioned Equation 2. Then, as shown in FIG. 11(c), the null byte places are removed, so as to rearrange the order, by using Equation 3 shown below. Thereafter, the symbol that is interleaved by the rearranged order is then outputted to the symbol-byte converter.

$$\text{if } P(i) > K-1, \text{ then } P(i) \text{ place is removed and rearranged} \quad \text{Equation 3}$$

Subsequently, the symbol-byte converter 404 converts to bytes the mobile service data symbols, having the rearrang-

ing of the symbol order completed and then outputted in accordance with the rearranged order, and thereafter outputs the converted bytes to the group formatter 304.

FIG. 12A illustrates a block diagram showing the structure of a block processor according to another embodiment of the present invention. Herein, the block processor includes an interleaving unit 610 and a block formatter 620. The interleaving unit 610 may include a byte-symbol converter 611, a symbol-byte converter 612, a symbol interleaver 613, and a symbol-byte converter 614. Herein, the symbol interleaver 613 may also be referred to as a block interleaver.

The byte-symbol converter 611 of the interleaving unit 610 converts the mobile service data X outputted in byte units from the RS frame encoder 302 to symbol units. Then, the byte-symbol converter 611 outputs the converted mobile service data symbols to the symbol-byte converter 612 and the symbol interleaver 613. More specifically, the byte-symbol converter 611 converts each 2 bits of the inputted mobile service data byte (=8 bits) to 1 symbol and outputs the converted symbols. This is because the input data of the trellis encoding module 256 consist of symbol units configured of 2 bits. The relationship between the block processor 303 and the trellis encoding module 256 will be described in detail in a later process. At this point, the byte-symbol converter 611 may also receive signaling information including transmission parameters. Furthermore, the signaling information bytes may also be divided into symbol units and then outputted to the symbol-byte converter 612 and the symbol interleaver 613.

The symbol-byte converter 612 groups 4 symbols outputted from the byte-symbol converter 611 so as to configure a byte. Thereafter, the converted data bytes are outputted to the block formatter 620. Herein, each of the symbol-byte converter 612 and the byte-symbol converter 611 respectively performs an inverse process on one another. Therefore, the yield of these two blocks is offset. Accordingly, as shown in FIG. 12B, the input data X bypass the byte-symbol converter 611 and the symbol-byte converter 612 and are directly inputted to the block formatter 620. More specifically, the interleaving unit 610 of FIG. 12B has a structure equivalent to that of the interleaving unit shown in FIG. 12A. Therefore, the same reference numerals will be used in FIG. 12A and FIG. 12B.

The symbol interleaver 613 performs block interleaving in symbol units on the data that are outputted from the byte-symbol converter 611. Subsequently, the symbol interleaver 613 outputs the interleaved data to the symbol-byte converter 614. Herein, any type of interleaver that can rearrange the structural order may be used as the symbol interleaver 613 of the present invention. In the example given in the present invention, a variable length interleaver that may be applied for symbols having a wide range of lengths, the order of which is to be rearranged. For example, the symbol interleaver of FIG. 11 may also be used in the block processor shown in FIG. 12A and FIG. 12B.

The symbol-byte converter 614 outputs the symbols having the rearranging of the symbol order completed, in accordance with the rearranged order. Thereafter, the symbols are grouped to be configured in byte units, which are then outputted to the block formatter 620. More specifically, the symbol-byte converter 614 groups 4 symbols outputted from the symbol interleaver 613 so as to configure a data byte. As shown in FIG. 13, the block formatter 620 performs the process of aligning the output of each symbol-byte converter 612 and 614 within the block in accordance

with a set standard. Herein, the block formatter **620** operates in association with the trellis encoding module **256**.

More specifically, the block formatter **620** decides the output order of the mobile service data outputted from each symbol-byte converter **612** and **614** while taking into consideration the place (or order) of the data excluding the mobile service data that are being inputted, wherein the mobile service data include main service data, known data, RS parity data, and MPEG header data.

According to the embodiment of the present invention, the trellis encoding module **256** is provided with 12 trellis encoders. FIG. **14** illustrates a block diagram showing the trellis encoding module **256** according to the present invention. In the example shown in FIG. **14**, 12 identical trellis encoders are combined to the interleaver in order to disperse noise. Herein, each trellis encoder may be provided with a precoder.

FIG. **15A** illustrates the block processor **303** being concatenated with the trellis encoding module **256**. In the transmitting system, a plurality of blocks actually exists between the pre-processor **230** including the block processor **303** and the trellis encoding module **256**, as shown in FIG. **3**. Conversely, the receiving system considers the pre-processor **230** to be concatenated with the trellis encoding module **256**, thereby performing the decoding process accordingly. However, the data excluding the mobile service data that are being inputted to the trellis encoding module **256**, wherein the mobile service data include main service data, known data, RS parity data, and MPEG header data, correspond to data that are added to the blocks existing between the block processor **303** and the trellis encoding module **256**. FIG. **15B** illustrates an example of a data processor **650** being positioned between the block processor **303** and the trellis encoding module **256**, while taking the above-described instance into consideration.

Herein, when the interleaving unit **610** of the block processor **303** performs a $\frac{1}{2}$ -rate encoding process, the interleaving unit **610** may be configured as shown in FIG. **12A** (or FIG. **12B**). Referring to FIG. **3**, for example, the data processor **650** may include a group formatter **304**, a data deinterleaver **305**, a packet formatter **306**, a packet multiplexer **240**, and a post-processor **250**, wherein the post-processor **250** includes a data randomizer **251**, a RS encoder/non-systematic RS encoder **252**, a data interleaver **253**, a parity replacer **254**, and a non-systematic RS encoder **255**.

At this point, the trellis encoding module **256** symbolizes the data that are being inputted so as to divide the symbolized data and to send the divided data to each trellis encoder in accordance with a pre-defined method. Herein, one byte is converted into 4 symbols, each being configured of 2 bits. Also, the symbols created from the single data byte are all transmitted to the same trellis encoder. Accordingly, each trellis encoder pre-codes an upper bit of the input symbol, which is then outputted as the uppermost output bit **C2**. Alternatively, each trellis encoder trellis-encodes a lower bit of the input symbol, which is then outputted as two output bits **C1** and **C0**. The block formatter **620** is controlled so that the data byte outputted from each symbol-byte converter can be transmitted to different trellis encoders.

Hereinafter, the operation of the block formatter **620** will now be described in detail with reference to FIG. **9** to FIG. **12**. Referring to FIG. **12A**, for example, the data byte outputted from the symbol-byte converter **612** and the data byte outputted from the symbol-byte converter **614** are inputted to different trellis encoders of the trellis encoding module **256** in accordance with the control of the block

formatter **620**. Hereinafter, the data byte outputted from the symbol-byte converter **612** will be referred to as X, and the data byte outputted from the symbol-byte converter **614** will be referred to as Y, for simplicity. Referring to FIG. **13(a)**, each number (i.e., 0 to 11) indicates the first to twelfth trellis encoders of the trellis encoding module **256**, respectively.

In addition, the output order of both symbol-byte converters are arranged (or aligned) so that the data bytes outputted from the symbol-byte converter **612** are respectively inputted to the 0th to 5th trellis encoders (0 to 5) of the trellis encoding module **256**, and that the data bytes outputted from the symbol-byte converter **614** are respectively inputted to the 6th to 11th trellis encoders (6 to 11) of the trellis encoding module **256**. Herein, the trellis encoders having the data bytes outputted from the symbol-byte converter **612** allocated therein, and the trellis encoders having the data bytes outputted from the symbol-byte converter **614** allocated therein are merely examples given to simplify the understanding of the present invention. Furthermore, according to an embodiment of the present invention, and assuming that the input data of the block processor **303** correspond to a block configured of 12 bytes, the symbol-byte converter **612** outputs 12 data bytes from **X0** to **X11**, and the symbol-byte converter **614** outputs 12 data bytes from **Y0** to **Y11**.

FIG. **13(b)** illustrates an example of data being inputted to the trellis encoding module **256**. Particularly, FIG. **13(b)** illustrates an example of not only the mobile service data but also the main service data and RS parity data being inputted to the trellis encoding module **256**, so as to be distributed to each trellis encoder. More specifically, the mobile service data outputted from the block processor **303** pass through the group formatter **304**, from which the mobile service data are mixed with the main service data and RS parity data and then outputted, as shown in FIG. **13(a)**. Accordingly, each data byte is respectively inputted to the 12 trellis encoders in accordance with the positions (or places) within the data group after being data-interleaved.

Herein, when the output data bytes X and Y of the symbol-byte converters **612** and **614** are allocated to each respective trellis encoder, the input of each trellis encoder may be configured as shown in FIG. **13(b)**. More specifically, referring to FIG. **13(b)**, the six mobile service data bytes (**X0** to **X5**) outputted from the symbol-byte converter **612** are sequentially allocated (or distributed) to the first to sixth trellis encoders (0 to 5) of the trellis encoding module **256**. Also, the 2 mobile service data bytes **Y0** and **Y1** outputted from the symbol-byte converter **614** are sequentially allocated to the 7th and 8th trellis encoders (6 and 7) of the trellis encoding module **256**. Thereafter, among the 5 main service data bytes, 4 data bytes are sequentially allocated to the 9th and 12th trellis encoders (8 to 11) of the trellis encoding module **256**. Finally, the remaining 1 byte of the main service data byte is allocated once again to the first trellis encoder (0).

It is assumed that the mobile service data, the main service data, and the RS parity data are allocated to each trellis encoder, as shown in FIG. **13(b)**. It is also assumed that, as described above, the input of the block processor **303** is configured of 12 bytes, and that 12 bytes from **X0** to **X11** are outputted from the symbol-byte converter **612**, and that 12 bytes from **Y0** to **Y11** are outputted from the symbol-byte converter **614**. In this case, as shown in FIG. **13(c)**, the block formatter **620** arranges the data bytes that are to be outputted from the symbol-byte converters **612** and **614** by the order of **X0** to **X5**, **Y0**, **Y1**, **X6** to **X10**, **Y2** to **Y7**, **X11**, and **Y8** to **Y11**. More specifically, the trellis encoder that is to perform

the encoding process is decided based upon the position (or place) within the transmission frame in which each data byte is inserted. At this point, not only the mobile service data but also the main service data, the MPEG header data, and the RS parity data are also inputted to the trellis encoding module **256**. Herein, it is assumed that, in order to perform the above-described operation, the block formatter **620** is informed of (or knows) the information on the data group format after the data-interleaving process.

FIG. **16** illustrates a block diagram of the block processor performing an encoding process at a coding rate of $1/N$ according to an embodiment of the present invention. Herein, the block processor includes $(N-1)$ number of symbol interleavers **741** to **74N-1**, which are configured in a parallel structure. More specifically, the block processor having the coding rate of $1/N$ consists of a total of N number of branches (or paths) including a branch (or path), which is directly transmitted to the block formatter **730**. In addition, the symbol interleaver **741** to **74N-1** of each branch may each be configured of a different symbol interleaver. Furthermore, $(N-1)$ number of symbol-byte converter **751** to **75N-1** each corresponding to each $(N-1)$ number of symbol interleavers **741** to **74N-1** may be included at the end of each symbol interleaver, respectively. Herein, the output data of the $(N-1)$ number of symbol-byte converter **751** to **75N-1** are also inputted to the block formatter **730**.

In the example of the present invention, N is equal to or smaller than 12. If N is equal to 12, the block formatter **730** may align the output data so that the output byte of the 12th symbol-byte converter **75N-1** is inputted to the 12th trellis encoder. Alternatively, if N is equal to 3, the block formatter **730** may arranged the output order, so that the data bytes outputted from the symbol-byte converter **720** are inputted to the 1st to 4th trellis encoders of the trellis encoding module **256**, and that the data bytes outputted from the symbol-byte converter **751** are inputted to the 5th to 8th trellis encoders, and that the data bytes outputted from the symbol-byte converter **752** are inputted to the 9th to 12th trellis encoders. At this point, the order of the data bytes outputted from each symbol-byte converter may vary in accordance with the position within the data group of the data other than the mobile service data, which are mixed with the mobile service data that are outputted from each symbol-byte converter.

FIG. **17** illustrates a detailed block diagram showing the structure of a block processor according to another embodiment of the present invention. Herein, the block formatter is removed from the block processor so that the operation of the block formatter may be performed by a group formatter. More specifically, the block processor of FIG. **17** may include a byte-symbol converter **810**, symbol-byte converters **820** and **840**, and a symbol interleaver **830**. In this case, the output of each symbol-byte converter **820** and **840** is inputted to the group formatter **850**.

Also, the block processor may obtain a desired coding rate by adding symbol interleavers and symbol-byte converters. If the system designer wishes a coding rate of $1/N$, the block processor needs to be provided with a total of N number of branches (or paths) including a branch (or path), which is directly transmitted to the block formatter **850**, and $(N-1)$ number of symbol interleavers and symbol-byte converters configured in a parallel structure with $(N-1)$ number of branches. At this point, the group formatter **850** inserts place holders ensuring the positions (or places) for the MPEG header, the non-systematic RS parity, and the main service

data. And, at the same time, the group formatter **850** positions the data bytes outputted from each branch of the block processor.

The number of trellis encoders, the number of symbol-byte converters, and the number of symbol interleavers proposed in the present invention are merely exemplary. And, therefore, the corresponding numbers do not limit the spirit or scope of the present invention. It is apparent to those skilled in the art that the type and position of each data byte being allocated to each trellis encoder of the trellis encoding module **256** may vary in accordance with the data group format. Therefore, the present invention should not be understood merely by the examples given in the description set forth herein. The mobile service data that are encoded at a coding rate of $1/N$ and outputted from the block processor **303** are inputted to the group formatter **304**. Herein, in the example of the present invention, the order of the output data outputted from the block formatter of the block processor **303** are aligned and outputted in accordance with the position of the data bytes within the data group.

Signaling Information Processing

The transmitter **200** according to the present invention may insert transmission parameters by using a plurality of methods and in a plurality of positions (or places), which are then transmitted to the receiving system. For simplicity, the definition of a transmission parameter that is to be transmitted from the transmitter to the receiving system will now be described. The transmission parameter includes data group information, region information within a data group, the number of RS frames configuring a super frame (i.e., a super frame size (SFS)), the number of RS parity data bytes (P) for each column within the RS frame, whether or not a checksum, which is added to determine the presence of an error in a row direction within the RS frame, has been used, the type and size of the checksum if the checksum is used (presently, 2 bytes are added to the CRC), the number of data groups configuring one RS frame—since the RS frame is transmitted to one burst section, the number of data groups configuring the one RS frame is identical to the number of data groups within one burst (i.e., burst size (BS)), a turbo code mode, and a RS code mode.

Also, the transmission parameter required for receiving a burst includes a burst period—herein, one burst period corresponds to a value obtained by counting the number of fields starting from the beginning of a current burst until the beginning of a next burst, a positioning order of the RS frames that are currently being transmitted within a super frame (i.e., a permuted frame index (PFI)) or a positioning order of groups that are currently being transmitted within a RS frame (burst) (i.e., a group index (GI)), and a burst size. Depending upon the method of managing a burst, the transmission parameter also includes the number of fields remaining until the beginning of the next burst (i.e., time to next burst (TNB)). And, by transmitting such information as the transmission parameter, each data group being transmitted to the receiving system may indicate a relative distance (or number of fields) between a current position and the beginning of a next burst.

The information included in the transmission parameter corresponds to examples given to facilitate the understanding of the present invention. Therefore, the proposed examples do not limit the scope or spirit of the present invention and may be easily varied or modified by anyone skilled in the art. According to the first embodiment of the present invention, the transmission parameter may be inserted by allocating a predetermined region of the mobile service data packet or the data group. In this case, the

receiving system performs synchronization and equalization on a received signal, which is then decoded by symbol units. Thereafter, the packet deformatter may separate the mobile service data and the transmission parameter so as to detect the transmission parameter. According to the first embodiment, the transmission parameter may be inserted from the group formatter **304** and then transmitted.

According to the second embodiment of the present invention, the transmission parameter may be multiplexed with another type of data. For example, when known data are multiplexed with the mobile service data, a transmission parameter may be inserted, instead of the known data, in a place (or position) where a known data byte is to be inserted. Alternatively, the transmission parameter may be mixed with the known data and then inserted in the place where the known data byte is to be inserted. According to the second embodiment, the transmission parameter may be inserted from the group formatter **304** or from the packet formatter **306** and then transmitted.

According to a third embodiment of the present invention, the transmission parameter may be inserted by allocating a portion of a reserved region within a field synchronization segment of a transmission frame. In this case, since the receiving system may perform decoding on a receiving signal by symbol units before detecting the transmission parameter, the transmission parameter having information on the processing methods of the block processor **303** and the group formatter **304** may be inserted in a reserved field of a field synchronization signal. More specifically, the receiving system obtains field synchronization by using a field synchronization segment so as to detect the transmission parameter from a pre-decided position. According to the third embodiment, the transmission parameter may be inserted from the synchronization multiplexer **240** and then transmitted.

According to the fourth embodiment of the present invention, the transmission parameter may be inserted in a layer (or hierarchical region) higher than a transport stream (TS) packet. In this case, the receiving system should be able to receive a signal and process the received signal to a layer higher than the TS packet in advance. At this point, the transmission parameter may be used to certify the transmission parameter of a currently received signal and to provide the transmission parameter of a signal that is to be received in a later process.

In the present invention, the variety of transmission parameters associated with the transmission signal may be inserted and transmitted by using the above-described methods according to the first to fourth embodiment of the present invention. At this point, the transmission parameter may be inserted and transmitted by using only one of the four embodiments described above, or by using a selection of the above-described embodiments, or by using all of the above-described embodiments. Furthermore, the information included in the transmission parameter may be duplicated and inserted in each embodiment. Alternatively, only the required information may be inserted in the corresponding position of the corresponding embodiment and then transmitted. Furthermore, in order to ensure robustness of the transmission parameter, a block encoding process of a short cycle (or period) may be performed on the transmission parameter and, then, inserted in a corresponding region. The method for performing a short-period block encoding process on the transmission parameter may include, for example, Kerdock encoding, BCH encoding, RS encoding, and repetition encoding of the transmission parameter. Also,

a combination of a plurality of block encoding methods may also be performed on the transmission parameter.

The transmission parameters may be grouped to create a block code of a small size, so as to be inserted in a byte place allocated within the data group for signaling and then transmitted. However, in this case, the block code passes through the block decoded from the receiving end so as to obtain a transmission parameter value. Therefore, the transmission parameters of the turbo code mode and the RS code mode, which are required for block decoding, should first be obtained. Accordingly, the transmission parameters associated with a particular mode may be inserted in a specific section of a known data region. And, in this case, a correlation of with a symbol may be used for a faster decoding process. The receiving system refers to the correlation between each sequence and the currently received sequences, thereby determining the encoding mode and the combination mode.

Meanwhile, when the transmission parameter is inserted in the field synchronization segment region or the known data region and then transmitted, and when the transmission parameter has passed through the transmission channel, the reliability of the transmission parameter is deteriorated. Therefore, one of a plurality of pre-defined patterns may also be inserted in accordance with the corresponding transmission parameter. Herein, the receiving system performs a correlation calculation between the received signal and the predefined patterns so as to recognize the transmission parameter. For example, it is assumed that a burst including 5 data groups is pre-decided as pattern A based upon an agreement between the transmitting system and the receiving system. In this case, the transmitting system inserts and transmits pattern A, when the number of groups within the burst is equal to 5. Thereafter, the receiving system calculates a correlation between the received data and a plurality of reference patterns including pattern A, which was created in advance. At this point, if the correlation value between the received data and pattern A is the greatest, the received data indicates the corresponding parameter, and most particularly, the number of groups within the burst. At this point, the number of groups may be acknowledged as 5. Hereinafter, the process of inserting and transmitting the transmission parameter will now be described according to first, second, and third embodiments of the present invention.

First Embodiment

FIG. **18** illustrates a schematic diagram of the group formatter **304** receiving the transmission parameter and inserting the received transmission parameter in region A of the data group according to the present invention. Herein, the group formatter **304** receives mobile service data from the block processor **303**. Conversely, the transmission parameter is processed with at least one of a data randomizing process, a RS frame encoding process, and a block processing process, and may then be inputted to the group formatter **304**. Alternatively, the transmission parameter may be directly inputted to the group formatter **304** without being processed with any of the above-mentioned processes. In addition, the transmission parameter may be provided from the service multiplexer **100**. Alternatively, the transmission parameter may also be generated and provided from within the transmitter **200**. The transmission parameter may also include information required by the receiving system in order to receive and process the data included in the data group. For example, the transmission parameter may include data group information, and multiplexing information.

The group formatter **304** inserts the mobile service data and transmission parameter which are to be inputted to corresponding regions within the data group in accordance with a rule for configuring a data group. For example, the transmission parameter passes through a block encoding process of a short period and is, then, inserted in region A of the data group. Particularly, the transmission parameter may be inserted in a pre-arranged and arbitrary position (or place) within region A. If it is assumed that the transmission parameter has been block encoded by the block processor **303**, the block processor **303** performs the same data processing operation as the mobile service data, more specifically, either a $\frac{1}{2}$ -rate encoding or $\frac{1}{4}$ -rate encoding process on the signaling information including the transmission parameter. Thereafter, the block processor **303** outputs the processed transmission parameter to the group formatter **304**. Thereafter, the signaling information is also recognized as the mobile service data and processed accordingly.

FIG. **19** illustrates a block diagram showing an example of the block processor receiving the transmission parameter and processing the received transmission parameter with the same process as the mobile service data. Particularly, FIG. **19** illustrates an example showing the structure of FIG. **9** further including a signaling information provider **411** and multiplexer **412**. More specifically, the signaling information provider **411** outputs the signaling information including the transmission parameter to the multiplexer **412**. The multiplexer **412** multiplexes the signaling information and the output of the RS frame encoder **302**. Then, the multiplexer **412** outputs the multiplexed data to the byte-bit converter **401**.

The byte-bit converter **401** divides the mobile service data bytes or signaling information byte outputted from the multiplexer **412** into bits, which are then outputted to the symbol encoder **402**. The subsequent operations are identical to those described in FIG. **9**. Therefore, a detailed description of the same will be omitted for simplicity. If any of the detailed structures of the block processor **303** shown in FIG. **12**, FIG. **15**, FIG. **16**, and FIG. **17**, the signaling information provider **411** and the multiplexer **412** may be provided behind the byte-symbol converter.

Second Embodiment

Meanwhile, when known data generated from the group formatter in accordance with a pre-decided rule are inserted in a corresponding region within the data group, a transmission parameter may be inserted in at least a portion of a region, where known data may be inserted, instead of the known data. For example, when a long known data sequence is inserted at the beginning of region A within the data group, a transmission parameter may be inserted in at least a portion of the beginning of region A instead of the known data. A portion of the known data sequence that is inserted in the remaining portion of region A, excluding the portion in which the transmission parameter is inserted, may be used to detect a starting point of the data group by the receiving system. Alternatively, another portion of region A may be used for channel equalization by the receiving system.

In addition, when the transmission parameter is inserted in the known data region instead of the actual known data. The transmission parameter may be block encoded in short periods and then inserted. Also, as described above, the transmission parameter may also be inserted based upon a pre-defined pattern in accordance with the transmission parameter. If the group formatter **304** inserts known data place holders in a region within the data group, wherein

known data may be inserted, instead of the actual known data, the transmission parameter may be inserted by the packet formatter **306**. More specifically, when the group formatter **304** inserts the known data place holders, the packet formatter **306** may insert the known data instead of the known data place holders. Alternatively, when the group formatter **304** inserts the known data, the known data may be directly outputted without modification.

FIG. **20** illustrates a block diagram showing the structure of a packet formatter **306** being expanded so that the packet formatter **306** can insert the transmission parameter according to an embodiment of the present invention. More specifically, the structure of the packet formatter **306** further includes a known data generator **351** and a signaling multiplexer **352**. Herein, the transmission parameter that is inputted to the signaling multiplexer **352** may include information on the length of a current burst, information indicating a starting point of a next burst, positions in which the groups within the burst exist and the lengths of the groups, information on the time from the current group and the next group within the burst, and information on known data.

The signaling multiplexer **352** selects one of the transmission parameter and the known data generated from the known data generator **351** and, then, outputs the selected data to the packet formatter **306**. The packet formatter **306** inserts the known data or transmission parameter outputted from the signaling multiplexer **352** into the known data place holders outputted from the data interleaver **305**. Then, the packet formatter **306** outputs the processed data. More specifically, the packet formatter **306** inserts a transmission parameter in at least a portion of the known data region instead of the known data, which is then outputted. For example, when a known data place holder is inserted at a beginning portion of region A within the data group, a transmission parameter may be inserted in a portion of the known data place holder instead of the actual known data.

Also, when the transmission parameter is inserted in the known data place holder instead of the known data, the transmission parameter may be block encoded in short periods and inserted. Alternatively, a pre-defined pattern may be inserted in accordance with the transmission parameter. More specifically, the signaling multiplexer **352** multiplexes the known data and the transmission parameter (or the pattern defined by the transmission parameter) so as to configure a new known data sequence. Then, the signaling multiplexer **352** outputs the newly configured known data sequence to the packet formatter **306**. The packet formatter **306** deletes the main service data place holder and RS parity place holder from the output of the data interleaver **305**, and creates a mobile service data packet of 188 bytes by using the mobile service data, MPEG header, and the output of the signaling multiplexer. Then, the packet formatter **306** outputs the newly created mobile service data packet to the packet multiplexer **240**.

In this case, the region A of each data group has a different known data pattern. Therefore, the receiving system separates only the symbol in a pre-arranged section of the known data sequence and recognizes the separated symbol as the transmission parameter. Herein, depending upon the design of the transmitting system, the known data may be inserted in different blocks, such as the packet formatter **306**, the group formatter **304**, or the block processor **303**. Therefore, a transmission parameter may be inserted instead of the known data in the block wherein the known data are to be inserted.

According to the second embodiment of the present invention, a transmission parameter including information

on the processing method of the block processor **303** may be inserted in a portion of the known data region and then transmitted. In this case, a symbol processing method and position of the symbol for the actual transmission parameter symbol are already decided. Also, the position of the transmission parameter symbol should be positioned so as to be transmitted or received earlier than any other data symbols that are to be decoded. Accordingly, the receiving system may detect the transmission symbol before the data symbol decoding process, so as to use the detected transmission symbol for the decoding process.

Third Embodiment

Meanwhile, the transmission parameter may also be inserted in the field synchronization segment region and then transmitted. FIG. **21** illustrates a block diagram showing the synchronization multiplexer being expanded in order to allow the transmission parameter to be inserted in the field synchronization segment region. Herein, a signaling multiplexer **261** is further included in the synchronization multiplexer **260**. The transmission parameter of the general VSB method is configured of 2 fields. More specifically, each field is configured of one field synchronization segment and 312 data segments. Herein, the first symbols of a data segment correspond to the segment synchronization portion, and the first data segment of each field corresponds to the field synchronization portion.

One field synchronization signal is configured to have the length of one data segment. The data segment synchronization pattern exists in the first 4 symbols, which are then followed by pseudo random sequences PN **511**, PN **63**, PN **63**, and PN **63**. The next symbols include information associated with the VSB mode. Additionally, the 24 symbols that include information associated with the VSB mode are followed by the remaining 104 symbols, which are reserved symbols. Herein, the last 12 symbols of a previous segment are copied and positioned as the last 12 symbols in the reserved region. In other words, only the 92 symbols in the field synchronization segment are the symbols that correspond to the actual reserved region.

Therefore, the signaling multiplexer **261** multiplexes the transmission parameter with an already-existing field synchronization segment symbol, so that the transmission parameter can be inserted in the reserved region of the field synchronization segment. Then, the signaling multiplexer **261** outputs the multiplexed transmission parameter to the synchronization multiplexer **260**. The synchronization multiplexer **260** multiplexes the segment synchronization symbol, the data symbols, and the new field synchronization segment outputted from the signaling multiplexer **261**, thereby configuring a new transmission frame. The transmission frame including the field synchronization segment, wherein the transmission parameter is inserted, is outputted to the transmission unit **270**. At this point, the reserved region within the field synchronization segment for inserting the transmission parameter may correspond to a portion of or the entire 92 symbols of the reserved region. Herein, the transmission parameter being inserted in the reserved region may, for example, include information identifying the transmission parameter as the main service data, the mobile service data, or a different type of mobile service data.

If the information on the processing method of the block processor **303** is transmitted as a portion of the transmission parameter, and when the receiving system wishes to perform a decoding process corresponding to the block processor **303**, the receiving system should be informed of such

information on the block processing method in order to perform the decoding process. Therefore, the information on the processing method of the block processor **303** should already be known prior to the block decoding process. Accordingly, as described in the third embodiment of the present invention, when the transmission parameter having the information on the processing method of the block processor **303** (and/or the group formatter **304**) is inserted in the reserved region of the field synchronization signal and then transmitted, the receiving system is capable of detecting the transmission parameter prior to performing the block decoding process on the received signal.

Receiving System

FIG. **22** illustrates a block diagram showing a structure of a digital broadcast receiving system according to the present invention. The digital broadcast receiving system of FIG. **22** uses known data information, which is inserted in the mobile service data section and, then, transmitted by the transmitting system, so as to perform carrier synchronization recovery, frame synchronization recovery, and channel equalization, thereby enhancing the receiving performance. Referring to FIG. **22**, the digital broadcast receiving system includes a tuner **901**, a demodulator **902**, an equalizer **903**, a known data detector **904**, a block decoder **905**, a data deformatter **906**, a RS frame decoder **907**, a derandomizer **908**, a data deinterleaver **909**, a RS decoder **910**, and a data derandomizer **911**. Herein, for simplicity of the description of the present invention, the data deformatter **906**, the RS frame decoder **907**, and the derandomizer **908** will be collectively referred to as a mobile service data processing unit. And, the data deinterleaver **909**, the RS decoder **910**, and the data derandomizer **911** will be collectively referred to as a main service data processing unit.

More specifically, the tuner **901** tunes a frequency of a particular channel and down-converts the tuned frequency to an intermediate frequency (IF) signal. Then, the tuner **901** outputs the down-converted IF signal to the demodulator **902** and the known data detector **904**. The demodulator **902** performs self gain control, carrier recovery, and timing recovery processes on the inputted IF signal, thereby modifying the IF signal to a baseband signal. Then, the demodulator **902** outputs the newly created baseband signal to the equalizer **903** and the known data detector **904**. The equalizer **903** compensates the distortion of the channel included in the demodulated signal and then outputs the error-compensated signal to the block decoder **905**.

At this point, the known data detector **904** detects the known sequence place inserted by the transmitting end from the input/output data of the demodulator **902** (i.e., the data prior to the demodulation process or the data after the demodulation process). Thereafter, the place information along with the symbol sequence of the known data, which are generated from the detected place, is outputted to the demodulator **902** and the equalizer **903**. Also, the known data detector **904** outputs a set of information to the block decoder **905**. This set of information is used to allow the block decoder **905** of the receiving system to identify the mobile service data that are processed with additional encoding from the transmitting system and the main service data that are not processed with additional encoding. In addition, although the connection status is not shown in FIG. **22**, the information detected from the known data detector **904** may be used throughout the entire receiving system and may also be used in the data deformatter **906** and the RS frame decoder **907**. The demodulator **902** uses the known data symbol sequence during the timing and/or carrier recovery, thereby enhancing the demodulating performance.

Similarly, the equalizer **903** uses the known data so as to enhance the equalizing performance. Moreover, the decoding result of the block decoder **905** may be fed-back to the equalizer **903**, thereby enhancing the equalizing performance.

The equalizer **903** may perform channel equalization by using a plurality of methods. An example of estimating a channel impulse response (CIR) so as to perform channel equalization will be given in the description of the present invention. Most particularly, an example of estimating the CIR in accordance with each region within the data group, which is hierarchically divided and transmitted from the transmitting system, and applying each CIR differently will also be described herein. Furthermore, by using the known data, the place and contents of which is known in accordance with an agreement between the transmitting system and the receiving system, and the field synchronization data, so as to estimate the CIR, the present invention may be able to perform channel equalization with more stability.

Herein, the data group that is inputted for the equalization process is divided into regions A to C, as shown in FIG. 6A. More specifically, in the example of the present invention, each region A, B, and C are further divided into regions A1 to A5, regions B1 and B2, and regions C1 to C3, respectively. Referring to FIG. 6A, the CIR that is estimated from the field synchronization data in the data structure is referred to as CIR_FS. Alternatively, the CIRs that are estimated from each of the 5 known data sequences existing in region A are sequentially referred to as CIR_N0, CIR_N1, CIR_N2, CIR_N3, and CIR_N4.

As described above, the present invention uses the CIR estimated from the field synchronization data and the known data sequences in order to perform channel equalization on data within the data group. At this point, each of the estimated CIRs may be directly used in accordance with the characteristics of each region within the data group. Alternatively, a plurality of the estimated CIRs may also be either interpolated or extrapolated so as to create a new CIR, which is then used for the channel equalization process.

Herein, when a value $F(A)$ of a function $F(x)$ at a particular point A and a value $F(B)$ of the function $F(x)$ at another particular point B are known, interpolation refers to estimating a function value of a point within the section between points A and B. Linear interpolation corresponds to the simplest form among a wide range of interpolation operations. The linear interpolation described herein is merely exemplary among a wide range of possible interpolation methods. And, therefore, the present invention is not limited only to the examples set forth herein.

Alternatively, when a value $F(A)$ of a function $F(x)$ at a particular point A and a value $F(B)$ of the function $F(x)$ at another particular point B are known, extrapolation refers to estimating a function value of a point outside of the section between points A and B. Linear extrapolation is the simplest form among a wide range of extrapolation operations. Similarly, the linear extrapolation described herein is merely exemplary among a wide range of possible extrapolation methods. And, therefore, the present invention is not limited only to the examples set forth herein.

More specifically, in case of region C1, any one of the CIR_N4 estimated from a previous data group, the CIR_FS estimated from the current data group that is to be processed with channel equalization, and a new CIR generated by extrapolating the CIR_FS of the current data group and the CIR_N0 may be used to perform channel equalization. Alternatively, in case of region B1, a variety of methods may be applied as described in the case for region C1. For

example, a new CIR created by linearly extrapolating the CIR_FS estimated from the current data group and the CIR_N0 may be used to perform channel equalization. Also, the CIR_FS estimated from the current data group may also be used to perform channel equalization. Finally, in case of region A1, a new CIR may be created by interpolating the CIR_FS estimated from the current data group and CIR_N0, which is then used to perform channel equalization. Furthermore, any one of the CIR_FS estimated from the current data group and CIR_N0 may be used to perform channel equalization.

In case of regions A2 to A5, CIR_N(i-1) estimated from the current data group and CIR_N(i) may be interpolated to create a new CIR and use the newly created CIR to perform channel equalization. Also, any one of the CIR_N(i-1) estimated from the current data group and the CIR_N(i) may be used to perform channel equalization. Alternatively, in case of regions B2, C2, and C3, CIR_N3 and CIR_N4 both estimated from the current data group may be extrapolated to create a new CIR, which is then used to perform the channel equalization process. Furthermore, the CIR_N4 estimated from the current data group may be used to perform the channel equalization process. Accordingly, an optimum performance may be obtained when performing channel equalization on the data inserted in the data group. The methods of obtaining the CIRs required for performing the channel equalization process in each region within the data group, as described above, are merely examples given to facilitate the understanding of the present invention. A wider range of methods may also be used herein. And, therefore, the present invention will not only be limited to the examples given in the description set forth herein.

Meanwhile, if the data being inputted to the block decoder **905** after being channel equalized from the equalizer **903** correspond to the mobile service data having additional encoding and trellis encoding performed thereon by the transmitting system, trellis decoding and additional decoding processes are performed on the inputted data as inverse processes of the transmitting system. Alternatively, if the data being inputted to the block decoder **905** correspond to the main service data having only trellis encoding performed thereon, and not the additional encoding, only the trellis decoding process is performed on the inputted data as the inverse process of the transmitting system.

The data group decoded by the block decoder **905** is inputted to the data deformatter **906**, and the main service data are inputted to the data deinterleaver **909**. According to another embodiment, the main data may also bypass the block decoder **905** so as to be directly inputted to the data deinterleaver **909**. In this case, a trellis decoder for the main service data should be provided before the data deinterleaver **909**. When the block decoder **905** outputs the data group to the data deformatter **906**, the known data, trellis initialization data, and MPEG header, which are inserted in the data group, and the RS parity, which is added by the RS encoder/non-systematic RS encoder or non-systematic RS encoder of the transmitting system, are removed. Then, the processed data are outputted to the data deformatter **906**. Herein, the removal of the data may be performed before the block decoding process, or may be performed during or after the block decoding process. If the transmitting system includes signaling information in the data group upon transmission, the signaling information is outputted to the data deformatter **906**.

More specifically, if the inputted data correspond to the main service data, the block decoder **905** performs Viterbi decoding on the inputted data so as to output a hard decision

value or to perform a hard-decision on a soft decision value, thereby outputting the result. Meanwhile, if the inputted data correspond to the mobile service data, the block decoder **905** outputs a hard decision value or a soft decision value with respect to the inputted mobile service data. In other words, if the inputted data correspond to the mobile service data, the block decoder **905** performs a decoding process on the data encoded by the block processor and trellis encoding module of the transmitting system.

At this point, the RS frame encoder of the pre-processor included in the transmitting system may be viewed as an external code. And, the block processor and the trellis encoder may be viewed as an internal code. In order to maximize the performance of the external code when decoding such concatenated codes, the decoder of the internal code should output a soft decision value. Therefore, the block decoder **905** may output a hard decision value on the mobile service data. However, when required, it may be more preferable for the block decoder **905** to output a soft decision value.

Meanwhile, the data deinterleaver **909**, the RS decoder **910**, and the derandomizer **911** are blocks required for receiving the main service data. Therefore, the above-mentioned blocks may not be required in the structure of a digital broadcast receiving system that only receives the mobile service data. The data deinterleaver **909** performs an inverse process of the data interleaver included in the transmitting system. In other words, the data deinterleaver **909** deinterleaves the main service data outputted from the block decoder **905** and outputs the deinterleaved main service data to the RS decoder **910**. The RS decoder **910** performs a systematic RS decoding process on the deinterleaved data and outputs the processed data to the derandomizer **911**. The derandomizer **911** receives the output of the RS decoder **910** and generates a pseudo random data byte identical to that of the randomizer included in the digital broadcast transmitting system. Thereafter, the derandomizer **911** performs a bitwise exclusive OR (XOR) operation on the generated pseudo random data byte, thereby inserting the MPEG synchronization bytes to the beginning of each packet so as to output the data in 188-byte main service data packet units.

Meanwhile, the data being outputted from the block decoder **905** to the data deformatter **906** are inputted in the form of a data group. At this point, the data deformatter **906** already knows the structure of the data that are to be inputted and is, therefore, capable of identifying the signaling information, which includes the system information, and the mobile service data from the data group. Thereafter, the data deformatter **906** outputs the identified signaling information to a block for processing signaling information (not shown) and outputs the identified mobile service data to the RS frame decoder **907**. More specifically, the RS frame decoder **907** receives only the RS encoded and CRC encoded mobile service data that are transmitted from the data deformatter **906**.

The RS frame encoder **907** performs an inverse process of the RS frame encoder included in the transmitting system so as to correct the error within the RS frame. Then, the RS frame decoder **907** adds the 1-byte MPEG synchronization service data packet, which had been removed during the RS frame encoding process, to the error-corrected mobile service data packet. Thereafter, the processed data packet is outputted to the derandomizer **908**. The operation of the RS frame decoder **907** will be described in detail in a later process. The derandomizer **908** performs a derandomizing process, which corresponds to the inverse process of the randomizer included in the transmitting system, on the

received mobile service data. Thereafter, the derandomized data are outputted, thereby obtaining the mobile service data transmitted from the transmitting system. Hereinafter, detailed operations of the RS frame decoder **907** will now be described.

FIG. **23** illustrates a series of exemplary step of an error correction decoding process of the RS frame decoder **907** according to the present invention. More specifically, the RS frame decoder **907** groups mobile service data bytes received from the data deformatter **906** so as to configure an RS frame. The mobile service data correspond to data RS encoded and CRC encoded from the transmitting system. FIG. **23(a)** illustrates an example of configuring the RS frame. More specifically, the transmitting system divided the RS frame having the size of $(N+2)*235$ to $30*235$ byte blocks. When it is assumed that each of the divided mobile service data byte blocks is inserted in each data group and then transmitted, the receiving system also groups the $30*235$ mobile service data byte blocks respectively inserted in each data group, thereby configuring an RS frame having the size of $(N+2)*235$. For example, when it is assumed that an RS frame is divided into 18 $30*235$ byte blocks and transmitted from a burst section, the receiving system also groups the mobile service data bytes of 18 data groups within the corresponding burst section, so as to configure the RS frame. Furthermore, when it is assumed that N is equal to 538 (i.e., $N=538$), the RS frame decoder **907** may group the mobile service data bytes within the 18 data groups included in a burst so as to configure a RS frame having the size of $540*235$ bytes.

Herein, when it is assumed that the block decoder **905** outputs a soft decision value for the decoding result, the RS frame decoder **907** may decide the '0' and '1' of the corresponding bit by using the codes of the soft decision value. 8 bits that are each decided as described above are grouped to create 1 data byte. If the above-described process is performed on all soft decision values of the 18 data groups included in a single burst, the RS frame having the size of $540*235$ bytes may be configured. Additionally, the present invention uses the soft decision value not only to configure the RS frame but also to configure a reliability map. Herein, the reliability map indicates the reliability of the corresponding data byte, which is configured by grouping 8 bits, the 8 bits being decided by the codes of the soft decision value.

For example, when the absolute value of the soft decision value exceeds a pre-determined threshold value, the value of the corresponding bit, which is decided by the code of the corresponding soft decision value, is determined to be reliable. Conversely, when the absolute value of the soft decision value does not exceed the pre-determined threshold value, the value of the corresponding bit is determined to be unreliable. Thereafter, if even a single bit among the 8 bits, which are decided by the codes of the soft decision value and group to configure 1 data byte, is determined to be unreliable, the corresponding data byte is marked on the reliability map as an unreliable data byte.

Herein, determining the reliability of 1 data byte is only exemplary. More specifically, when a plurality of data bytes (e.g., at least 4 data bytes) are determined to be unreliable, the corresponding data bytes may also be marked as unreliable data bytes within the reliability map. Conversely, when all of the data bits within the 1 data byte are determined to be reliable (i.e., when the absolute value of the soft decision values of all 8 bits included in the 1 data byte exceed the predetermined threshold value), the corresponding data byte is marked to be a reliable data byte on the reliability map. Similarly, when a plurality of data bytes

(e.g., at least 4 data bytes) are determined to be reliable, the corresponding data bytes may also be marked as reliable data bytes within the reliability map. The numbers proposed in the above-described example are merely exemplary and, therefore, do not limit the scope or spirit of the present invention.

The process of configuring the RS frame and the process of configuring the reliability map both using the soft decision value may be performed at the same time. Herein, the reliability information within the reliability map is in a one-to-one correspondence with each byte within the RS frame. For example, if a RS frame has the size of 540×235 bytes, the reliability map is also configured to have the size of 540×235 bytes. FIG. 23(a') illustrates the process steps of configuring the reliability map according to the present invention. Meanwhile, if a RS frame is configured to have the size of $(N+2) \times 235$ bytes, the RS frame decoder 907 performs a CRC syndrome checking process on the corresponding RS frame, thereby verifying whether any error has occurred in each row. Subsequently, as shown in FIG. 23(b), a 2-byte checksum is removed to configure an RS frame having the size of $N \times 235$ bytes. Herein, the presence (or existence) of an error is indicated on an error flag corresponding to each row. Similarly, since the portion of the reliability map corresponding to the CRC checksum has hardly any applicability, this portion is removed so that only $N \times 235$ number of the reliability information bytes remain, as shown in FIG. 23(b').

After performing the CRC syndrome checking process, the RS frame decoder 907 performs RS decoding in a column direction. Herein, a RS erasure correction process may be performed in accordance with the number of CRC error flags. More specifically, as shown in FIG. 23(c), the CRC error flag corresponding to each row within the RS frame is verified. Thereafter, the RS frame decoder 907 determines whether the number of rows having a CRC error occurring therein is equal to or smaller than the maximum number of errors on which the RS erasure correction may be performed, when performing the RS decoding process in a column direction. The maximum number of errors corresponds to a number of parity bytes inserted when performing the RS encoding process. In the embodiment of the present invention, it is assumed that 48 parity bytes have been added to each column.

If the number of rows having the CRC errors occurring therein is smaller than or equal to the maximum number of errors (i.e., 48 errors according to this embodiment) that can be corrected by the RS erasure decoding process, a $(235, 187)$ -RS erasure decoding process is performed in a column direction on the RS frame having 235 N-byte rows, as shown in FIG. 23(d). Thereafter, as shown in FIG. 23(f), the 48-byte parity data that have been added at the end of each column are removed. Conversely, however, if the number of rows having the CRC errors occurring therein is greater than the maximum number of errors (i.e., 48 errors) that can be corrected by the RS erasure decoding process, the RS erasure decoding process cannot be performed. In this case, the error may be corrected by performing a general RS decoding process. In addition, the reliability map, which has been created based upon the soft decision value along with the RS frame, may be used to further enhance the error correction ability (or performance) of the present invention.

More specifically, the RS frame decoder 907 compares the absolute value of the soft decision value of the block decoder 905 with the pre-determined threshold value, so as to determine the reliability of the bit value decided by the code of the corresponding soft decision value. Also, 8 bits, each

being determined by the code of the soft decision value, are grouped to form 1 data byte. Accordingly, the reliability information on this 1 data byte is indicated on the reliability map. Therefore, as shown in FIG. 23(e), even though a particular row is determined to have an error occurring therein based upon a CRC syndrome checking process on the particular row, the present invention does not assume that all bytes included in the row have errors occurring therein. The present invention refers to the reliability information of the reliability map and sets only the bytes that have been determined to be unreliable as erroneous bytes. In other words, with disregard to whether or not a CRC error exists within the corresponding row, only the bytes that are determined to be unreliable based upon the reliability map are set as erasure points.

According to another method, when it is determined that CRC errors are included in the corresponding row, based upon the result of the CRC syndrome checking result, only the bytes that are determined by the reliability map to be unreliable are set as errors. More specifically, only the bytes corresponding to the row that is determined to have errors included therein and being determined to be unreliable based upon the reliability information, are set as the erasure points. Thereafter, if the number of error points for each column is smaller than or equal to the maximum number of errors (i.e., 48 errors) that can be corrected by the RS erasure decoding process, an RS erasure decoding process is performed on the corresponding column. Conversely, if the number of error points for each column is greater than the maximum number of errors (i.e., 48 errors) that can be corrected by the RS erasure decoding process, a general decoding process is performed on the corresponding column.

More specifically, if the number of rows having CRC errors included therein is greater than the maximum number of errors (i.e., 48 errors) that can be corrected by the RS erasure decoding process, either an RS erasure decoding process or a general RS decoding process is performed on a column that is decided based upon the reliability information of the reliability map, in accordance with the number of erasure points within the corresponding column. For example, it is assumed that the number of rows having CRC errors included therein within the RS frame is greater than 48. And, it is also assumed that the number of erasure points decided based upon the reliability information of the reliability map is indicated as 40 erasure points in the first column and as 50 erasure points in the second column. In this case, a $(235, 187)$ -RS erasure decoding process is performed on the first column. Alternatively, a $(235, 187)$ -RS decoding process is performed on the second column. When error correction decoding is performed on all column directions within the RS frame by using the above-described process, the 48-byte parity data which were added at the end of each column are removed, as shown in FIG. 23(f).

As described above, even though the total number of CRC errors corresponding to each row within the RS frame is greater than the maximum number of errors that can be corrected by the RS erasure decoding process, when the number of bytes determined to have a low reliability level, based upon the reliability information on the reliability map within a particular column, while performing error correction decoding on the particular column. Herein, the difference between the general RS decoding process and the RS erasure decoding process is the number of errors that can be corrected. More specifically, when performing the general RS decoding process, the number of errors corresponding to half of the number of parity bytes (i.e., $(\text{number of parity bytes})/2$) that are inserted during the RS encoding process

may be error corrected (e.g., 24 errors may be corrected). Alternatively, when performing the RS erasure decoding process, the number of errors corresponding to the number of parity bytes that are inserted during the RS encoding process may be error corrected (e.g., 48 errors may be corrected).

After performing the error correction decoding process, as described above, a RS frame configured of 187 N-byte rows (or packets) maybe obtained, as shown in FIG. 23(f). Furthermore, the RS frame having the size of N*187 bytes is sequentially outputted in N number of 187-byte units. Herein, as shown in FIG. 23(g), the 1-byte MPEG synchronization byte that was removed by the transmitting system is added at the end of each 187-byte packet, thereby outputting 188-byte mobile service data packets.

As described above, the digital broadcasting system and the data processing method according to the present invention have the following advantages. More specifically, the digital broadcasting receiving system and method according to the present invention is highly protected against (or resistant to) any error that may occur when transmitting mobile service data through a channel. And, the present invention is also highly compatible to the conventional receiving system. Moreover, the present invention may also receive the mobile service data without any error even in channels having severe ghost effect and noise.

Additionally, by inserting known data in a particular position (or place) within a data region and transmitting the processed data, the receiving performance of the receiving system may be enhanced even in a channel environment that is liable to frequent changes. Also, by multiplexing mobile service data with main service data into a burst structure, the power consumption of the receiving system may be reduced. Furthermore, the present invention is even more effective when applied to mobile and portable receivers, which are also liable to a frequent change in channel and which require protection (or resistance) against intense noise.

Hereinafter, an example of transmitting/receiving time information of main service data and mobile service data when the broadcast transmitting/receiving system multiplexes the main service data and the mobile service data and transmits the multiplexed data will be described. Here, the time information may be provided in the form of a table including at least one section and, hereinafter, will be referred to as program table information. For example, the program table information may become information according to program specific information (PSI)/program and system information protocol (PSIP). Hereinafter, a fixed reception channel indicates a channel which can allow the broadcasting system to transmit/receive the main service data and a mobile reception channel indicates a channel which can allow the broadcasting system to transmit/receive the mobile service data.

Hereinafter, a process of obtaining time information at the broadcast transmitting/receiving system will be described. The broadcast receiving system obtains the time information from the broadcast transmitting system. For example, as described above, a mobile broadcast transmitting/receiving system based on the ATSC system obtains the time information through the program table information such as a system time table (STT).

FIG. 24 is a view showing the STT which may be used in the ATSC system. The STT is used for transmitting current date and information. In the ATSC system, the PID of a transport stream for delivering the STT is 0x1FFB, and transport_scrambling_control indicating whether the payload of the packet is scrambled is "00". Since an adaptation

field is not set in the program table information, adaptation_field control has a value of "01".

As shown in FIG. 24, the table_id of the STT is an 8-bit field which is set to 0xCD. The section_syntax_indicator is a 1-bit field which is set to 1 and indicates MPEG long-form. The private_indicator is a 1-bit field which is set to 1 and section_length is a 12-bit field indicating the length of the section. The table_id_extension is set to 0 in the STT and the version number is a 5-bit field which indicates the version number of the section and is set to 0. The current_next_indicator is a 1-bit identifier which indicates application to the current section and is set to 1 in the STT section. The section_number is an 8-bit field which has a value of 1 because the STT has one section length. The last_section_number is an 8-bit field which is set to 0. The protocol version is an 8-bit field which is set to 0 in the STT.

The system_time is a 32-bit field which indicates the count of global positioning system (GPS) seconds that have occurred since 00:00:00 UTC time. Accordingly, the system_time becomes the time information based on universal time coordinated (UTC) (that is, time information relative to a standard time).

The GPS_UTC_offset indicates a difference between a GPS time and a UTC time in seconds. In order to convert the GPS time to the UTC time, GPS_UTC_offset is subtracted from the GPS time.

The daylight_saving is 2-byte data which is used for considering a period in which a time called a summer time is applied in Korea. The daylight_savings includes an identifier DS_status indicating whether a daylight saving time is applied or a standard time is applied, an identifier DS_day_of month indicating a day of a month when the daylight saving time is applied or canceled, and an identifier DS_hour indicating a time when the daylight saving time is applied or canceled.

The STT may have a descriptor having a variable length.

The broadcast receiving system includes a system clock managed by an operating system (OS). If the system clock is in a manual mode, a time which is manually set by the user is maintained. Alternatively, if the system clock is in an automatic mode and information considering a time zone which is automatically set (a region to which a local time is applied) and daylight saving is set by the user, the system clock maintains the system time using time information including a time transmitted from the broadcasting station using the set information, such as the UTC time. For example, the broadcast receiving system calculates the local time of the time zone from the time zone set by the user, calculates the local time of the broadcast receiving system using the UTC time received from the broadcasting signal, and sets the system time on the basis of the calculated times.

However, when the broadcast receiving system can receive the broadcasting signal while moving between the time zones, the time of the region is changed according to the time zone and thus the system time of the broadcast receiving system should be changed. Since the broadcast receiving system receives the time such as the UTC time from the broadcasting station of the region in which the broadcast receiving system is located and calculates the system time on the basis of the received time, the user should change the time of the broadcast receiving system or change the time zone information. If the system time maintained by the broadcast receiving system is changed, the broadcast receiving system cannot output the broadcast at an accurate time according to the region and cannot output broadcasting information such as EPG at an accurate time according to the region.

FIG. 25 is a view showing an example where the broadcast receiving system obtains time information. For example, it is assumed that the broadcast receiving system is located in New York. It is assumed that New York belongs to an Eastern time zone and an Eastern time is 10:30 AM. It is assumed that the time information received from the broadcasting station is the UTC time.

If the broadcast receiving system is located in the Eastern time zone, the user sets 10:30 AM, which is less than the UTC time by 5 hours, as the local time in the broadcast receiving system. If the broadcast receiving system moves to Los Angeles (LA), a time difference between the time which is set in the broadcast receiving system and the local time of LA is 3 hours. That is, the local time of Los Angeles is 7:30 AM which follows Pacific time zone and is less than the UTC time by 8 hours. Accordingly, if the broadcast receiving system receives and processes the broadcasting signal from the broadcasting station located in LA and the user does not reset the time of the broadcast receiving system, an error occurs by the time difference between the time which is originally set and the local time of LA, when the broadcasting signal is processed.

For example, it is assumed that two broadcasting events are present in the EIT at the current time in the broadcasting signals of LA. It is assumed that the two broadcasting events include a program entitled "Prison Break", which starts at 14:00 UTC of LA (6 AM in the local time), and a program entitled "Rome", which starts at 15:30 UTC (7:30 AM in the local time).

Since the EIT received by the broadcast receiving system includes the time information according to the UTC, the broadcast receiving system may generate a time error in program information. For example, if the broadcast receiving system extracts information related to the broadcasting program from the EIT information and outputs an electronic program guide (EPG), the broadcast receiving system outputs information that the program "Prison Break" starts at 9 AM and the program "Rome" starts at 10:30 AM, according to the time set by the Eastern time. Accordingly, when the broadcast receiving system moves to LA, since the time information included in the broadcasting signal received actually is not equal to the time information of the broadcast receiving system, an operation error may occur when the broadcasting information is output. That is, the start time of the program included in the broadcasting signal received by the broadcast receiving system is the UTC time. Accordingly, if the UTC time is changed to the local time according to the time of the time zone in the broadcast receiving system, the broadcast receiving system changes the start times of the programs to the Eastern time. Since the time difference between the changed time information and the time information of the region, in which the broadcast receiving system is currently located, is 3 hours, the information according to the accurate time cannot be provided to the user.

FIG. 26 is a view showing the time information of a broadcasting signal including the time information according to regions. If the broadcast transmitting/receiving system transmits/receives the broadcasting signal shown in the example of FIG. 26, although the broadcast receiving system receives the broadcasting signal while moving, an error does not occur when the broadcasting signal is processed. A broadcasting transmitter (broadcasting station) may transmit at least one of an identifier of the time zone, in which the transmitter is located, and time difference between the time according to the time zone information and the standard time. FIG. 26 shows an example of indicating information

for allowing the time information to be accurately processed although the region, in which the broadcast receiving system receives the broadcasting program, is changed, by a descriptor. The descriptor shown in FIG. 26 may be, for example, included in the descriptor of the STT shown in FIG. 24 (or may be included in another descriptor of the PSI/PSIP). The descriptor of FIG. 26 includes descriptor_tag for identifying the descriptor and descriptor_length indicating the length of the descriptor. FIG. 26 shows an example of including time_zone_name_length which is the variable length of the time_zone_name for setting the time zone name and the time_zone_name which is the time zone name time zone name.

As shown in FIG. 26, the broadcast receiving system may receive time zone identifier information time_zone_id from the broadcasting station. If the broadcast receiving system receives the time information according to the region from the broadcasting signal, time zone time information of the broadcast receiving region, time difference information time_zone_offset between the local time of the time zone and the standard time and polarity information time_zone_offset_polarity indicating whether the time difference is added to or subtracted from the standard time (that is, whether the local time is later or earlier than the standard time) may be received. The standard time may be the UTC time.

The broadcast transmitting/receiving system can transmit/receive only the time zone identifier time_zone_id from the broadcasting signal. In this case, the broadcast receiving system may store the time difference information with the standard time, for example, in the form of a table and calculate the local time using the received time zone identifier. As another example, the broadcast transmitting/receiving system may transmit/receive only the time difference time_zone_offset between the local time and the standard time and the polarity information time_zone_offset_polarity from the broadcasting signal. In this case, the broadcast receiving system may calculate the local time from the UTC received from the STT.

FIG. 27 is a view showing the time information shown in FIG. 26. The time zones distributed in United States, for example, include Eastern (EST), Central (CT), Mountain (MT), Pacific (PT), Alaska, and Hawaii. According to the example of FIG. 26, the time zone names are set to Eastern, Central, Mountain, Pacific, Alaska and Hawaii. In FIG. 27, the time zone identifiers are set to 0x00 (Eastern), 0x01 (Central), 0x02 (Mountain), 0x03 (Pacific), 0x04 (Alaska) and 0x05 (Hawaii). If the polarity information time_zone_offset_polarity indicating whether the time of the time zone is later or earlier than the standard time is "0", the time of the time zone is earlier than the standard time and, if the polarity information time_zone_offset_polarity is "1", the time of the time zone is later than the standard time. Accordingly, since the polarity information time_zone_offset_polarity of the time zones is 1 and all the times of the time zones are later than the standard time (UTC time), the times of the time zones can be calculated by subtracting the time zone information time_zone_offset from the standard time (UTC time). The time difference information time_zone_offset between the standard time and the time of the time zone is 5 hours with respect to EST, 6 hours with respect to CT, 7 hours with respect to MT, 8 hours with respect to PT, 9 hours with respect to Alaska, and 10 hours with respect to Hawaii.

FIG. 28 is a conceptual view showing an example in which the broadcast receiving system receives the broadcasting signal according to the example of FIG. 26. The example of FIG. 28 is similar to that of FIG. 25. It is

assumed that the time information shown in FIG. 26 is transmitted/received from/to the program table information such as the STT.

The broadcast receiving system in which the time of the Eastern time zone is set to 10:30AM moves to the Pacific time zone. The broadcast receiving system can receive the UTC time which is the standard time of the STT from the Pacific time zone. In addition, the broadcast receiving system can receive the time information according to time_zone_descriptor shown in FIG. 27. The broadcast receiving system obtains "Pacific Time" as the time zone name time_zone_name and "0x03" (PT) as the time zone identifier from the time_zone_descriptor of the STT. The broadcast receiving system obtains "1" as the polarity information time_zone_offset_polarity and "8" as the time difference between the time of the time zone and the standard time time_zone_offset. Accordingly, even when the broadcast receiving system moves to LA, the broadcast receiving system may set the current time to 7:30AM, which is later than the UTC time by 8 hours, from the broadcasting signal. The EPG information may be output according to the Pacific time zone.

FIG. 29 is a flowchart illustrating an example of receiving the time information from the broadcasting signal. The example of receiving the time information of the region from the broadcasting signal will be described with reference to FIG. 29. The broadcast receiving system which can receive the mobile service data is powered on (S11).

The program table information in which the time zone identifier or the time difference between the time of the time zone, in which the broadcast receiving system is located, and the standard time is set, is demultiplexed from the broadcasting time (S12). For example, the program table information may be the STT. The STT may be transmitted/received at an interval of 1 second, which may be changed according to the transmitting/receiving system.

The time zone identifier or the time difference between the time of the time zone, in which the broadcast receiving system is located, and the standard time is identified from the STT. According to the above-described example, the above-described information may be identified and parsed from the time_zone_descriptor included in the STT.

The time zone identifier or the time difference between the time of the time zone, in which the broadcast receiving system is located, and the standard time is extracted, the local time of the region in which the broadcast receiving system is located is calculated, and the broadcasting information is processed according to the calculated time (S16).

If the time for receiving the change of the channel selected by the user, the power reset of the broadcast receiving system and a time for receiving the STT defined by the broadcast transmitting/receiving system is elapsed, the process returns to the step S12 of receiving the STT (S18).

FIG. 30 is a view showing an example of receiving the time information according to the time zone from the broadcasting signal and outputting the current time.

The broadcast receiving system which can receive the mobile service data is powered on (S11).

The user makes a request for the output of the time to the broadcast receiving system (S22).

The time information of the time zone and the standard time are extracted from the broadcasting signal (S24). For example, the time zone identifier or the time difference between the time of the time zone, in which the broadcast receiving system is located, and the standard time may be extracted from the STT.

The local time of the region in which the broadcast receiving system is located is calculated from the extracted time information of the time zone and standard time (S26).

The calculated local time is output (S28). Accordingly, the local time of the time zone may be automatically calculated and output even when the broadcast receiving system moves between the time zones.

FIG. 31 is a view showing an example of receiving the time information of the time zone from the broadcasting signal and outputting the broadcasting information. Now, the example of outputting the EPG in the broadcasting information will be described with reference to FIG. 31.

The broadcast receiving system which can receive the mobile service data is powered on (S11).

The user makes a request for the output of the information related to the broadcasting program, such as the EPG (S32).

The EIT is obtained from the broadcasting signal, and the broadcasting information related to the program included in the EIT, such as the program name and the start time and the end time of the program, is extracted (S34).

The STT is obtained from the broadcasting signal, the standard time (UTC) and the time difference between the time of the time zone, in which the broadcast receiving system is located, and the standard time included in the STT is extracted, and the local time of the region in which the broadcast receiving system is located is calculated from the extracted information (S36). The detailed description of the step S36 was made with respect to FIG. 29. The steps S34 and S36 may be implemented simultaneously or in the sequence inverse to the sequence shown in FIG. 31. The step S36 may be omitted if the broadcast receiving system previously calculates the local time by the process of FIG. 29.

The program information included in the EPG is output using the calculated local time information (S38).

FIG. 32 is a view showing an example of the broadcast receiving system. Referring to FIG. 32, the example of the broadcast receiving system will be described. The example of the broadcast receiving system includes a tuner 1100, a demodulator 1200, a demultiplexer 1300, a program table information decoder 1400, a controller 1500, a decoder 1600, a memory 1700 and an output unit 1800.

The tuner 1100 can receive the broadcasting signal transmitted through at least one of the fixed reception channel or the mobile reception channel. That is, the broadcasting signal received by the tuner 1100 may include the main service data and the mobile service data therein. The tuner 1100 tunes the channel selected by the user and outputs the broadcasting signal of the channel. The broadcasting signal received from the fixed reception channel may include a terrestrial/cable broadcasting signal. The tuner 1100 may receive the program table information including the time zone identifier or the time difference between the time of the time zone and the standard time, such as the STT.

The demodulator 1200 demodulates the signal output from the tuner 1100 and outputs the demodulated signal. The demodulator 1200 may demodulate at least one of the broadcasting signal transmitted through the fixed reception channel or the broadcasting signal transmitted through the mobile reception channel. For example, the demodulator 1200 may demodulate the 64 VSB/256 VSB modulation signal or demodulate 64QAM/256QAM modulation signal. The demodulator 1200 may demodulate the broadcasting signal of the fixed reception channel and the broadcasting signal of the mobile reception channel. The example of demodulating the mobile service data and the main service data is shown in FIG. 22 (refer to the operation and the

description of FIG. 22 excluding the tuner) in detail. The demodulator 1200 may not demodulate the broadcasting signal according to the null packets, which are transmitted so as to be matched to the transmission rate, in the received signal.

The demultiplexer 1300 may demultiplex the signal output from the demodulator 1200 and output the demultiplexed signal. The demultiplexer 1300 may directly receive the mobile service data stream or the main service data stream from an external device. For example, when the broadcast receiving system can receive the broadcasting stream from the digital VCR, the demultiplexer 1300 may directly receive and demultiplex the broadcasting stream through a predetermined interface, for example, an interface having the IEEE 1394 format. The demultiplexer 1300 may demultiplex the video stream, the audio stream and the program table information in the received broadcasting stream. For example, if the program table information according to the examples of FIGS. 26 to 32 is included in the received signal, the demultiplexer 1300 outputs the program table information to the program table information decoder 1400 and outputs the video and audio signals in the broadcasting signal to the decoder 1600. That is, the demultiplexer 1300 may demultiplex the program table information of the main service data and the mobile service data and the broadcasting signal and output the demultiplexed data. The demultiplexer 1300 may demultiplex the time zone identifier or the time difference between the time of the time zone and the standard time.

When a channel selection command is received from the controller 1500, the demultiplexer 1300 may output the video/audio stream according to the video/audio PID of the channel selected by the user to the decoder 1400.

The program table information decoder 1400 may decode the demultiplexed program table information and output the decoded information to the controller 1500. The program table information decoder 1400 may decode the program table information of the mobile service data/main service data. In this case, the program table information of the mobile service data and the program table information of the main service data may include the respective identifiers for identifying the service data. For example, if the program table information of the mobile service data and the program table information of the main service data include respective PIDs, the respective packets may be demultiplexed according to their PIDs. Alternatively, if the program table information of the mobile service data and the program table information of the main service data have the same PID and have the identifiers for identifying the service, the identifiers may be recognized as the separated tables and may be decoded. The program table information decoder 1400 may separately store the program table information of the mobile service data and the program table information of the main service data. The program table information decoder 1400 may parse the program table information including the time zone identifier or the time difference between the time of the time zone and the standard time and store the parsed information in the controller 1500. The program table information decoder 1400 may parse the broadcasting program information such as the EIT and store the parsed broadcast-

ing program information. The controller 1500 may control the components shown in FIG. 32 and store the information about the channel using the received program table information. For example, the controller 1500 may store the information about the video/audio/data stream of the channel in the form of a channel map using the parsed program table information. For

example, the controller 1500 may separately store the channel map of the mobile service data and the channel map of the main service data according to the form of the channel map.

The controller 1500 may receive a user control signal so through a user interface. When the user transmits the control signal such as the channel change, the controller 1500 may output the signal of the channel desired by the user by referring to the channel map information. Although the channel information of the mobile service data and the channel information of the main service data are stored in the form of a channel map, the controller 1500 may control the broadcasting signal transmitted through each channel to be output according to the channel information of each service. That is, the controller 1500 may control the tuner 1100, the demodulator 1200 and the demultiplexer 1300 such that the broadcasting signal of the channel is output, if the channel change between the virtual channels for providing the main service and the mobile service or the channel change between the virtual channels for providing the mobile service is made. For example, if a channel change command is received, the controller 1500 may select the channel changed through the tuner 1100 by referring to the channel map. The controller 1500 may control the demodulator 1200 such that the signal of the channel selected by the user is demodulated. For example, if the user selects the mobile reception channel, the controller 1500 may control the demodulator 1200 such that only the mobile service data in the burst section in which the mobile service data of the mobile reception channel is multiplexed is demodulated (the demodulation operation of the demodulator may refer to FIG. 22). If the user selects the fixed reception channel, the controller 1500 may control the demodulator 1200 such that only the main service data is demodulated. The controller 1500 may control the demultiplexer 1300 such that the packet of the broadcasting signal of the channel selected by the user is demultiplexed according to the stored channel map.

The controller 1500 may control the power of the blocks shown in FIG. 32. For example, if the broadcast receiving system shown in FIG. 32 receives the mobile service data, the power of the broadcast receiving system may be controlled such that the signal is received only in the burst section including the mobile service data of the reception channel. Accordingly, although the broadcast receiving system receives the signal of the mobile reception channel, it is possible to reduce power consumption. The controller 1500 may obtain the identifier of the burst section from the descriptor of the program table information or the signaling information. Accordingly, the controller 1500 may control the demodulator 1200 to demodulate only the burst section through the burst information indicating in which burst section the broadcasting signal of the channel desired by the user is transmitted. The controller may control the demultiplexer 1300 such that the broadcasting signal according to the PID of the broadcasting stream of the channel desired by the user is demultiplexed.

Meanwhile, the controller 1500 may control the application or the user interface of the broadcast receiving system of FIG. 32. The controller 1500 may update and manage the channel map through the program table information, control the tuner 1100 and the program table information decoder 1400, and operate a channel manager according to the channel request of the viewer. The channel manager may update the channel map using the program table information

which is newly received and control the demultiplexer **1300** to select the PID of the video/audio stream of the channel desired by the user.

The controller **1500** may change and maintain the local time of the system according to the time zone of the region in which the broadcast receiving system is located. The controller **1500** may receive the time zone identifier or the time difference between the time of the time zone and the standard time decoded by the program table information decoder **1400** and calculate the local time of the region, in which the broadcast receiving system is located, according to the received information. If the controller **1500** executes the application for outputting the EPG according to the user's request, the controller **1500** control the broadcasting program information such as EPG to be generated by using the program information (for example, information about the program name and the program start time and end time) stored by the program table information decoder **1400**.

The application executed by the controller **1500** may output the broadcasting program information to the user using the received program information. In this case, the controller **1500** may process the broadcasting information related to the time output from the program table information decoder **1400** according to the local time and output the processed information as the EPG. Alternatively, if the controller **1500** receives the broadcasting information from the program table information decoder **1400**, the program information to which the local time calculated according to the time zone is applied may be received. In this case, the program table information decoder **1400** previously applies the local time calculated by the controller **1500** to the decoded program table information and stores the program table information to which the local time is applied. For example, the program table information decoder **1400** may parse the EIT, convert the time information such as the program start/end time into the local time, and store the local time. When the signal for outputting the information about the broadcasting program and the contents is received from the user, the controller **1500** may convert the information into the local signal and output the stored broadcasting program information.

The decoder **1600** decodes the video and/or audio stream output from the demultiplexer **1300** and outputs the decoded stream. For example, the decoder **1600** may decode the audio stream encoded according to an AC-3 method or the video stream encoded by an MPEG-2 method.

The output unit **1800** may output the video/audio signal output from the decoder **1600**. In the example of FIG. **32**, the output unit **1800** includes a display unit for outputting the video signal and a speaker for outputting the audio signal. The output unit **1800** may display a graphic signal generated by the controller **1500** and the video signal displayed on the screen by an on-screen display (OSD). The signal output from output unit **1800** by the graphic signal includes the EPG information such as a channel number, broadcasting program information, broadcasting station information, a broadcasting title, a broadcasting time, a caption, a broadcasting class, and a detailed plot of a broadcasting contents. When the controller **1500** calculates the local time using the time zone identifier or the time difference between the time of the time zone and the standard time, the output unit **1800** may output the local time information calculated by the controller **1500** on the screen according to the user's request.

The memory **1700** may store data, such as channel information according to the channel map, and application. For example, the memory **1700** may be a nonvolatile random access memory (NVRAM) or a flash memory.

The signal demodulated by the demodulator **1200** may IP datagram. For example, referring to FIGS. **22** to **23**, the packet output from the RS frame decoder of the demodulator **1200** may be the packet including the IP datagram. Alternatively, in the example of FIG. **32**, the digital broadcasting system may receive the IP stream including the mobile service data through a network interface (not shown). In this case, the controller **1500** operates an IP manager such that the IP stream can be transmitted/received according to the IP and the IP stream can be transmitted/received according to the source and the destination of the IP stream. The controller **1500** operates a service manager such that a service provided by the IP stream received through the IP manager can be output in real time, and the service manager may implement the service including the video/audio received by the IP stream. For example, the service manager may control the service received by the IP protocol in real time. For example, if the service manager controls the real-time streaming data, the service data can be controlled using the real-time transport protocol/RTP control protocol (RTP/RTCP). The IP stream may include the program table information describing the mobile service data and the main service data in addition to the video/audio or the STT including the time zone identifier or the time difference between the time of the time zone and the standard time. If the IP stream is decoded, the program table information is processed as described above. Meanwhile, the controller **1500** may decode the data in the received IP datagram and store the decoded data in the memory **1700**. The controller **1500** may execute the application such that the data stored in the memory **1700** can be output or provided to the user.

FIG. **33** is a flowchart showing an example of receiving the broadcasting signal. The example of receiving the broadcasting signal will be described with reference to FIG. **33**.

The user powers on the broadcast receiving system (**S105**).

The user selects a physical channel or changes a physical channel tuned previously (**S110**). The channel map is formed or, if the channel map of the channel included in the received signal is previously formed, the channel tunes to the frequency of the channel selected according to the channel map (**S120**). The tuner may output the best tuned result to the controller for storing the channel map.

The tuned broadcasting signal is demodulated (**S130**). If the broadcasting signal is demodulated, the broadcast receiving system which can receive only the main service data may not demodulate the mobile service data, that is, may discard the mobile service data as the null packets. In contrast, the broadcast receiving system which receives the mobile service data demodulates the signal according to the method for modulating the mobile service data. The detailed demodulating process may refer to the example of FIG. **22**.

The program table information is multiplexed and parsed from the demodulated signal (**S140**). For example, after the PAT is received and parsed, the PMT information of the program may be parsed. In the program table information in the broadcasting signal, the program table information of the mobile service data and the program table information of the main service data are separately present. In this case, the same type of program table information of the main service data/mobile service data may have different PIDs. Although the same type of program table information of the main service data/mobile service data includes the same PID, the identifiers for identifying the services may be included. If the program table information including the identifiers for identifying the main service/mobile service is parsed in the step **5140**, the parsed program table information may be

separately managed. In the step S140, the program table information including the time zone identifier or the time difference between the time of the time zone and the standard time may be demultiplexed and parsed.

The information about the channel is obtained from the parsed program table information and the PID information of the audio/video/data ES of the channel is detected (S150). For example, the VCT is received and parsed such that the information about the channels can be obtained. In this case, the VCT for the fixed reception channel and the VCT for the mobile reception channel may be parsed and the information about the channels may be obtained.

The channel information detected in the step S150 is stored as the channel map or the stored channel map is updated. It is determined whether the service such as the audio/video/data ES of the channel information received according to the channel selected by the user is valid in the receiving system (S160). If the channel is not valid (No in the step S160), for example, "no channel" or "no signal" may be displayed to the user according to the predetermined channel operation (S165). In order to obtain the channel information of the valid channel, the process may return to the step S140 such that new program table information is received (S167).

If the channel selected by the user from the output channel information is the valid channel (Yes in the step S160), the PID of the audio/video/data stream of the virtual channel is selected according to the channel map (S170). The demodulating process of the step S130 is controlled depending on whether the channel selected by the viewer is the fixed reception channel or the mobile reception channel according to the channel map.

If the main service for the fixed reception channel is provided, the broadcasting signal of the channel is successively subjected to the channel tuning, demodulating and demultiplexing processes such that the main service data is output. In contrast, if the mobile service according to the mobile reception channel is provided, the broadcasting signal may be processed such that only the signal of the burst section including the broadcasting signal of the mobile reception channel selected by the user is subjected to the channel tuning, demodulating and demultiplexing processes. When the broadcasting signal is output, the channel number or the channel information selected by the OSD may be selectively displayed on the screen (S175).

The broadcast of the channel selected by the user is output (S180). The video/audio/data stream of the broadcasting signal transmitted through the selected virtual channel is decoded and output. The user can view a normal broadcast and control the broadcast reception through the OSD. In contrast, as shown in FIGS. 29 to 31, when the user makes a request for the time information such as the local time information or the information about the broadcasting program, such as the EPG, the information requested by the user may be output using the time zone identifier or the time difference between the time of the time zone and the standard time parsed in the step S140.

While the broadcast is viewed, the physical channel or the virtual channel may be changed (S190). If the physical channel is changed, the step S110 is performed and, if the virtual channel is changed, the step S170 is performed. If the channel is changed between the mobile reception channels or the channel is changed from the fixed reception channel to the mobile reception channel in the case where both the main service data and the mobile service data can be received, the step S170 is performed such that the burst including the broadcasting signal of the changed channel is

searched for and the broadcasting signal is demodulated only in the burst section. In contrast, if the channel is changed between the fixed reception channels or the channel is changed from the mobile reception channel to the fixed reception channel, the data of the section including the main service data is demodulated (if the main service data is included in the burst section, the data of the main service data section including the burst section can be demodulated).

If the channel is not changed, it may be determined whether the version of the channel information is updated (S200). If the channel information is updated, the information about the channel map is updated and the step S140 is performed in order to receive the new program table information. If the channel information is not updated, the step S180 may be performed.

If the user makes a request for the output of the local time or the output of the EPG information while the broadcast is viewed, the time may be output according to the processes of FIGS. 30 and 31.

According to the present invention, it is possible to provide a digital broadcasting system and a data processing method, which are robust against channel change or noise. In addition, it is possible to improve reception capability of a reception system by performing additional encoding processes with respect to mobile service data and transmitting the encoded mobile service data to the reception system. In addition, it is possible to improve reception capability of a reception system by inserting known data into a predetermined region of a data region and transmitting the data by an appointment of a transmitter and a receiver. Furthermore, it is possible to transmit program table information for mobile service data and main service data. In addition, it is possible to output time information and broadcasting information on the basis of the time change according to the mobile reception.

It will be apparent to those skilled in the art that various modifications and variations can be made in the present invention without departing from the spirit or scope of the invention. Thus, it is intended that the present invention covers the modifications and variations of this invention provided they come within the scope of the appended claims and their equivalents.

What is claimed is:

[1. A method of transmitting a broadcast signal in a transmitter, the method comprising:

pre-processing, by a preprocessor, first service data comprising audio or video data for a mobile service, the first service data capable of being transmitted via a same channel as second service data comprising audio or video data for a main service, wherein pre-processing the first service data comprises:

randomizing the first service data,

generating a Reed-Solomon (RS) frame through which an RS frame payload including the randomized first service data is RS—Cyclic Redundancy Check (RS-CRC) encoded, wherein the RS frame is separated into a plurality of portions, wherein a size of the RS frame payload is 187 by N bytes, and wherein N is an integer corresponding to a length of each row of the RS frame payload,

forming data groups of the first service data, wherein each data group includes signaling information, a plurality of known data sequences that have predetermined values, one of the plurality of portions, second service data place holders, RS parity data place holders, and MPEG header data place holders,

55

and wherein the signaling information includes information indicating a number of the data groups to be transmitted during a transmission frame, and removing the second service data place holders and the RS parity data place holders and replacing the MPEG header data place holders with MPEG header data to output first service data packets;

5 multiplexing, by a multiplexer, the first service data packets and second service data packets, wherein the second service data packets include the second service data;

10 randomizing, by a randomizer, the multiplexed second service data packets and the MPEG header data in the multiplexed first service data packets; and

15 transmitting, by a transmission unit, a broadcast signal that includes:

the first service data packets including the randomized MPEG header data, and

the randomized second service data packets,

20 wherein a parade of the formed data groups is transmitted during slots in the broadcast signal, the slots being basic time periods for multiplexing the first service data and the second service data.]

[2. The method of claim 1, wherein the first service data is mobile service data for display in mobile receivers and the second service data is main service data for display in legacy receivers.]

[3. The method of claim 1, wherein the signaling information further includes an RS code mode of the first service data.]

30 [4. A transmitter comprising:

a pre-processor for pre-processing first service data comprising audio or video data for a mobile service, the first service data is capable of being transmitted via a same channel as second service data comprising audio or video data for a main service, wherein pre-processing the first service data comprises:

35 randomizing the first service data,

generating a Reed-Solomon (RS) frame through which an RS frame payload including the randomized first service data is RS—Cyclic Redundancy Check (CRC) encoded, wherein the RS frame is separated to a plurality of portions, wherein a size of the RS frame payload is 187 by N bytes, and wherein N is an integer corresponding to a length of each row of the RS frame payload,

40 forming data groups of the first service data, wherein each data group includes signaling information, a plurality of known data sequences that have predetermined values, one of the plurality of portions, second service data place holders, RS parity data place holders, and MPEG header data place holders, and wherein the signaling information includes information indicating a number of the data groups to be transmitted during a transmission frame, and removing the second service data place holders and the RS parity data place holders and replacing the MPEG header data place holders with MPEG header data to output first service data packets;

45 a multiplexer for multiplexing the first service data packets and second service data packets, wherein the second service data packets include the second service data;

a randomizer for randomizing the multiplexed second service data packets and the MPEG header data in the multiplexed first service data packets; and

50 a transmission unit for transmitting a broadcast signal including:

56

the first service data packets including the randomized MPEG header data, and

the randomized second service data packets,

wherein a parade of the formed data groups is transmitted during slots in the broadcast signal, the slots being basic time periods for multiplexing the first service data and the second service data.]

[5. The transmitter of claim 4, wherein the first service data is mobile service data for display in mobile receivers and the second service data is main service data for display in legacy receivers.]

[6. The transmitter of claim 4, wherein the signaling information further includes an RS code mode of the first service data.]

7. A method of processing broadcast data in a receiver, the method comprising:

receiving a broadcast signal including a frame, wherein the frame includes broadcast service data for a service, service signaling information for the service, and transmission parameter data for signaling the broadcast service data, wherein the broadcast service data and the service signaling information are encoded to add parity data, encoded at a first code rate, and then block interleaved in an interleaving unit based on an interleaving pattern by a transmitter, wherein, when a size of a block including the broadcast service data and the service signaling information is smaller than a size of the interleaving unit, the interleaving unit includes the broadcast service data, the service signaling information and dummy data, wherein the dummy data not included in the block-interleaved data and are not transmitted to the receiver, and wherein the transmission parameter data are encoded at a second code rate by the transmitter;

35 demodulating the received broadcast signal;

decoding the transmission parameter data in the demodulated broadcast signal, wherein the transmission parameter data include information to identify a number of the parity data;

40 decoding the broadcast service data and the service signaling information in the demodulated broadcast signal; and

derandomizing the decoded broadcast service data and the decoded service signaling information,

45 wherein the service signaling information includes system time information and wherein the system time information includes offset information for identifying an offset between a local time zone of an originating broadcast station and Universal Time Coordinated (UTC), and status information for identifying whether a Daylight Saving Time is in effect.

8. The method of claim 7, wherein the frame further includes known data and wherein the transmission parameter data further include information on the known data.

9. The method of claim 8, further comprising:

50 equalizing the demodulated broadcast signal by performing channel estimation based on the known data.

10. A receiver for processing broadcast data, the receiver comprising:

55 a tuner to receive a broadcast signal including a frame, wherein the frame includes broadcast service data for a service, service signaling information for the service, and transmission parameter data for signaling the broadcast service data, wherein the broadcast service data and the service signaling information are encoded to add parity data, encoded at a first code rate, and then block interleaved in an interleaving unit based on

57

an interleaving pattern by a transmitter, wherein, when a size of a block including the broadcast service data and the service signaling information is smaller than a size of the interleaving unit, the interleaving unit includes the broadcast service data, the service signaling information and dummy data, wherein the dummy data are not included in the block-interleaved data and are not transmitted to the receiver, and wherein the transmission parameter data are encoded at a second code rate by the transmitter;

a demodulator to demodulate the received broadcast signal;

a first decoder to decode the transmission parameter data in the demodulated broadcast signal, wherein the transmission parameter data include information to identify a number of the parity data;

a second decoder to decode the broadcast service data and the service signaling information in the demodulated broadcast signal; and

58

a derandomizer to derandomize the decoded broadcast service data and the decoded service signaling information,

wherein the service signaling information includes system time information and wherein the system time information includes offset information for identifying an offset between a local time zone of an originating broadcast station and Universal Time Coordinated (UTC), and status information for identifying whether a Daylight Saving Time is in effect.

11. The receiver of claim 10, wherein the frame further includes known data and wherein the transmission parameter data further include information on the known data.

12. The receiver of claim 11, further comprising:
an equalizer to equalize the demodulated broadcast signal by performing channel estimation based on the known data.

* * * * *

UNITED STATES PATENT AND TRADEMARK OFFICE
CERTIFICATE OF CORRECTION

PATENT NO. : RE47,958 E
APPLICATION NO. : 15/833841
DATED : April 21, 2020
INVENTOR(S) : Song et al.

Page 1 of 1

It is certified that error appears in the above-identified patent and that said Letters Patent is hereby corrected as shown below:

In the Specification

At Column 1, please replace Lines 13-22 (approx.), with the following:

--CROSS-REFERENCE TO RELATED APPLICATIONS

NOTICE: More than one reissue application has been filed for the reissue of U.S. Patent No. 8,443,412 B2. The reissue applications are U.S. Reissue Patent Application Serial No. 16/852,176, filed on April 17, 2020, which is a continuation reissue application of U.S. Reissue Patent Application Serial No. 15/833,841 (the present application), filed on December 6, 2017, now U.S. Reissue Patent No. RE47,958 E, issued April 21, 2020, which is a continuation reissue application of U.S. Reissue Patent Application Serial No. 14/711,531, filed on May 13, 2015, now U.S. Reissue Patent No. RE46,676 E, issued January 16, 2018, which is a reissue application of U.S. Patent Application Serial No. 13/051,743, filed on March 18, 2011, now U.S. Patent No. 8,443,412 B2, issued May 14, 2013, which is a continuation--

Signed and Sealed this
Nineteenth Day of January, 2021

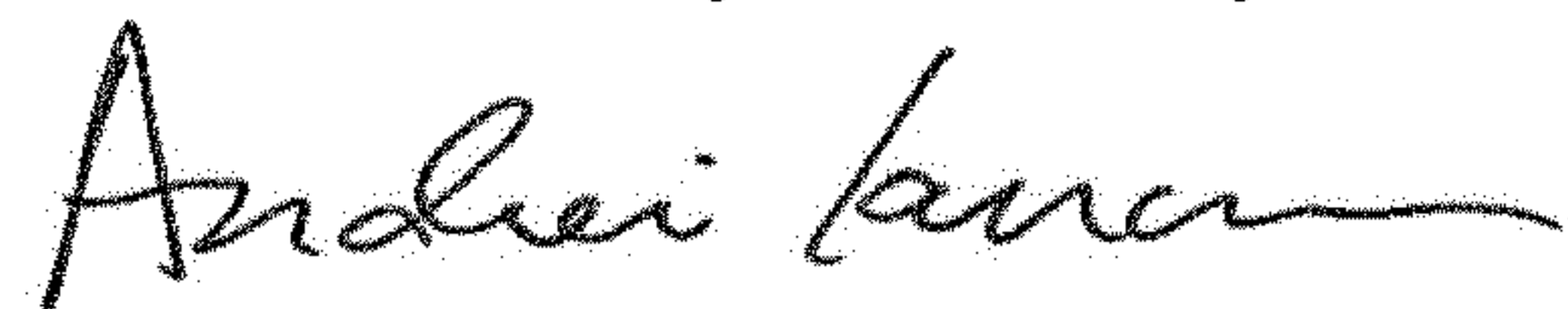

Andrei Iancu
Director of the United States Patent and Trademark Office

UNITED STATES PATENT AND TRADEMARK OFFICE
CERTIFICATE OF CORRECTION

PATENT NO. : RE47,958 E
APPLICATION NO. : 15/833841
DATED : April 21, 2020
INVENTOR(S) : Jae Hyung Song et al.

Page 1 of 1

It is certified that error appears in the above-identified patent and that said Letters Patent is hereby corrected as shown below:

In the Claims

Column 56, Lines 30-31, of Claim 7, replace “wherein the dummy data not included” with --wherein the dummy data are not included--.

Signed and Sealed this
Fourth Day of October, 2022

Katherine Kelly Vidal
Director of the United States Patent and Trademark Office