



US00RE47906E

(19) **United States**
(12) **Reissued Patent**
Wilde et al.

(10) **Patent Number:** **US RE47,906 E**
(45) **Date of Reissued Patent:** ***Mar. 17, 2020**

(54) **RECONFIGURABLE OPTICAL ADD-DROP MULTIPLEXERS WITH SERVO CONTROL AND DYNAMIC SPECTRAL POWER MANAGEMENT CAPABILITIES**

(71) Applicant: **CAPELLA PHOTONICS, INC.**, Mountain View, CA (US)

(72) Inventors: **Jeffrey P. Wilde**, Morgan Hill, CA (US); **Joseph E. Davis**, Morgan Hill, CA (US)

(73) Assignee: **Capella Photonics, Inc.**, Mountainview, CA (US)

(*) Notice: This patent is subject to a terminal disclaimer.

(21) Appl. No.: **16/023,183**

(22) Filed: **Jun. 29, 2018**

Related U.S. Patent Documents

Reissue of:

(64) Patent No.: **Re. 42,678**
Issued: **Sep. 6, 2011**
Appl. No.: **12/815,930**
Filed: **Jun. 15, 2010**

Which is a Reissue of:

(64) Patent No.: **Re. 39,397**
Issued: **Nov. 14, 2006**
Appl. No.: **11/027,586**
Filed: **Dec. 31, 2004**

Which is a Reissue of:

(64) Patent No.: **6,625,346**
Issued: **Sep. 23, 2003**
Appl. No.: **09/938,426**
Filed: **Aug. 23, 2001**

U.S. Applications:

(60) Provisional application No. 60/277,217, filed on Mar. 19, 2001.

(51) **Int. Cl.**

G02B 6/28 (2006.01)
G02B 6/293 (2006.01)

(Continued)

(52) **U.S. Cl.**
CPC **G02B 6/2931** (2013.01); **G02B 6/29313** (2013.01); **G02B 6/29383** (2013.01);
(Continued)

(58) **Field of Classification Search**
None
See application file for complete search history.

(56) **References Cited**

U.S. PATENT DOCUMENTS

4,367,040 A 1/1983 Goto
4,707,056 A 11/1987 Bittner
(Continued)

FOREIGN PATENT DOCUMENTS

JP H10-339825 A 12/1998
JP 2000-147247 A 5/2000
(Continued)

OTHER PUBLICATIONS

Riza et al. Digitally controlled fault-tolerant multiwavelength programmable fiber-optic attenuator using a 2-D digital micromirror device. Optics Letters. vol. 24, No. 5. Mar. 1, 1999. pp. 282-284. (Year: 1999).*

(Continued)

Primary Examiner — Deandra M Hughes
(74) *Attorney, Agent, or Firm* — Sterne, Kessler, Goldstein & Fox, P.L.L.C.

(57) **ABSTRACT**

This invention provides a novel wavelength-separating-routing (WSR) apparatus that uses a diffraction grating to separate a multi-wavelength optical signal by wavelength into multiple spectral characters, which are then focused onto an array of corresponding channel micromirrors. The channel micromirrors are individually controllable and continuously pivotable to reflect the spectral channels into selected output ports. As such, the inventive WSR apparatus is capable of routing the spectral channels on a channel-by-

(Continued)

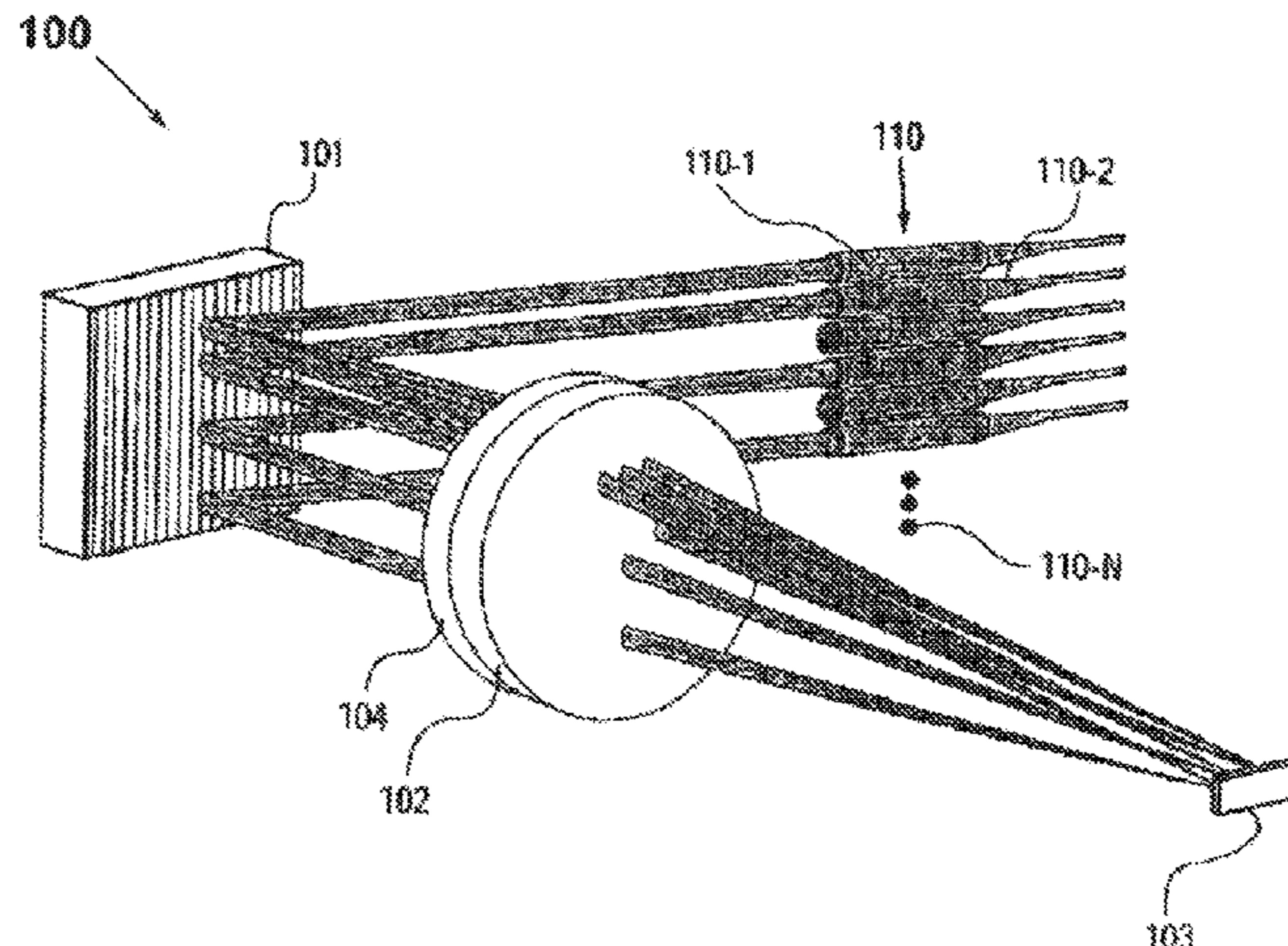

channel basis and coupling any spectral channel into any one of the output ports. The WSR apparatus of the present invention may be further equipped with servo-control and spectral power-management capabilities, thereby maintaining the coupling efficiencies of the spectral channels into the output ports at desired values. The WSR apparatus of the present invention can be used to construct a novel class of dynamically reconfigurable optical add-drop multiplexers (OADMs) for WDM optical networking applications.

72 Claims, 12 Drawing Sheets

(51) **Int. Cl.**

- G02B 6/35** (2006.01)
- G02B 26/08** (2006.01)
- G02B 6/34** (2006.01)
- G02B 6/32** (2006.01)

(52) **U.S. Cl.**

- CPC **G02B 6/29385** (2013.01); **G02B 6/29391** (2013.01); **G02B 6/29395** (2013.01); **G02B 6/3512** (2013.01); **G02B 6/3588** (2013.01); **G02B 6/32** (2013.01); **G02B 6/34** (2013.01); **G02B 6/356** (2013.01); **G02B 6/3556** (2013.01); **G02B 6/3586** (2013.01); **G02B 6/3592** (2013.01); **G02B 26/0833** (2013.01)

(56)

References Cited

U.S. PATENT DOCUMENTS

4,839,884	A	6/1989	Schloss	
5,233,405	A	8/1993	Wildnauer et al.	
5,311,606	A	5/1994	Asakura et al.	
5,414,540	A	5/1995	Patel et al.	359/39
5,477,350	A	12/1995	Riza et al.	
5,526,155	A	6/1996	Knox et al.	
5,600,851	A	2/1997	McLeod	
5,629,790	A *	5/1997	Neukermans et al.	359/198.1
5,661,591	A	8/1997	Lin et al.	
5,740,288	A	4/1998	Pan	
5,745,271	A	4/1998	Ford et al.	359/130
5,835,458	A *	11/1998	Bischel et al.	369/44.12
5,847,831	A	12/1998	Tomlinson et al.	
5,867,264	A	2/1999	Hinnrichs	
5,868,480	A	2/1999	Zeinali	
5,872,880	A	2/1999	Maynard	
5,875,272	A	2/1999	Kewitsch et al.	
5,881,199	A	3/1999	Li	
5,936,752	A	8/1999	Bishop et al.	
5,943,158	A	8/1999	Ford et al.	
5,960,133	A *	9/1999	Tomlinson	385/18
5,974,207	A *	10/1999	Aksyuk et al.	385/24
6,011,884	A	1/2000	Dueck et al.	
6,018,603	A	1/2000	Lundgren et al.	
6,028,689	A	2/2000	Michalicek et al.	359/224
6,069,719	A	5/2000	Mizrahi	
6,081,331	A	6/2000	Teichmann	
6,097,859	A	8/2000	Solgaard et al.	
6,134,359	A	10/2000	Keyworth et al.	
6,169,624	B1	1/2001	Godil et al.	
6,172,777	B1	1/2001	Flood et al.	
6,178,033	B1	1/2001	Ford et al.	
6,178,284	B1	1/2001	Bergmann et al.	
6,193,376	B1	2/2001	Hayashi et al.	
6,204,946	B1 *	3/2001	Aksyuk et al.	398/9
6,205,269	B1 *	3/2001	Morton	385/24
6,222,954	B1 *	4/2001	Riza	385/18
6,243,507	B1	6/2001	Goldstein et al.	
6,246,818	B1	6/2001	Fukushima	
6,253,001	B1 *	6/2001	Hoehn	G02B 6/3518 385/16

6,253,135	B1	7/2001	Wade	
6,256,430	B1	7/2001	Jin et al.	385/18
6,259,841	B1	7/2001	Bhagavatula	
6,263,127	B1	7/2001	Dragone et al.	
6,263,135	B1 *	7/2001	Wade	385/37
6,275,623	B1	8/2001	Brophy et al.	
6,285,500	B1	9/2001	Ranalli et al.	
6,289,155	B1 *	9/2001	Wade	385/37
6,307,657	B1	10/2001	Ford	359/130
6,343,862	B1	2/2002	Sawai et al.	
6,345,133	B1	2/2002	Morozov	
6,381,387	B1	4/2002	Wendland, Jr.	
6,415,070	B1	7/2002	Munoz-Bustamante et al.	
6,415,073	B1	7/2002	Cappiello et al.	
6,415,080	B1	7/2002	Sappey et al.	
6,418,250	B1 *	7/2002	Corbosiero et al.	385/24
6,439,728	B1	8/2002	Copeland	
6,442,307	B1	8/2002	Carr et al.	
6,453,087	B2	9/2002	Frish et al.	
6,498,872	B2	12/2002	Bouevitch et al.	709/318
6,507,421	B1	1/2003	Bishop et al.	
6,543,286	B2	4/2003	Garverick et al.	
6,549,699	B2	4/2003	Belser et al.	
6,567,574	B1	5/2003	Ma et al.	385/16
6,583,934	B2 *	6/2003	Kramer	G02B 5/1866 356/328
6,600,851	B2	7/2003	Aksyuk et al.	385/18
6,603,894	B1 *	8/2003	Pu	G02B 6/3582 359/223.1
6,625,340	B1	9/2003	Sparks et al.	
6,625,346	B2 *	9/2003	Wilde	385/24
6,631,222	B1	10/2003	Wagener et al.	385/16
6,634,810	B1	10/2003	Ford et al.	398/88
6,657,770	B2	12/2003	Marom et al.	
6,661,948	B2	12/2003	Wilde	
6,687,431	B2	2/2004	Chen et al.	
6,760,511	B2	7/2004	Garrett et al.	
6,768,571	B2	7/2004	Azarov et al.	
6,798,941	B2	9/2004	Smith et al.	
6,798,992	B1	9/2004	Bishop et al.	
6,810,169	B2	10/2004	Bouevitch	385/24
6,826,349	B2	11/2004	Weverka et al.	
6,842,549	B2	1/2005	So	
6,859,573	B2	2/2005	Bouevitch et al.	
6,879,750	B2	4/2005	Chen et al.	
6,898,348	B2	5/2005	Morozov et al.	385/37
6,928,244	B1	8/2005	Goldstein et al.	
6,950,609	B2	9/2005	Marom	
6,984,917	B2	1/2006	Greywall et al.	
6,989,921	B2	1/2006	Bernstein et al.	359/290
7,023,604	B2 *	4/2006	Behin	G02B 6/3556 359/226.1
RE39,331	E	10/2006	Chen et al.	
RE39,397	E *	11/2006	Wilde et al.	385/24
RE39,411	E	11/2006	Belser et al.	
7,183,633	B2	2/2007	Daneman et al.	257/678
RE39,515	E	3/2007	Garrett et al.	
RE39,525	E	3/2007	Wilde et al.	
7,676,126	B2	3/2010	McLaughlin et al.	
RE42,368	E	5/2011	Chen et al.	
RE42,521	E	7/2011	Garrett et al.	
RE42,678	E *	9/2011	Wilde	G02B 6/2931 385/24
8,233,794	B2	7/2012	Colbourne et al.	
2002/0081070	A1	6/2002	Tew	
2002/0097956	A1 *	7/2002	Kikuchi	G02B 6/327 385/33
2002/0105692	A1	8/2002	Lauder et al.	
2002/0131691	A1 *	9/2002	Garrett et al.	385/24
2003/0043471	A1 *	3/2003	Belser et al.	359/634

FOREIGN PATENT DOCUMENTS

JP	2002-519710	A	7/2002
JP	2003-504684	A	2/2003

(56)

References Cited

FOREIGN PATENT DOCUMENTS

JP 2003-506751 A 2/2003
 JP 2003-515187 A 4/2003

OTHER PUBLICATIONS

Lin et al. On the expandability of free-space micromachined optical cross-connects. *Journal of Lightwave Technology*. vol. 18, No. 4. Apr. 2000. pp. 482-489. (Year: 2000).*

Sumriddetchkajorn et al. Micromachine-based Fault-tolerant high resolution high-speed programmable fiber-optic attenuator. OSA-OFC 2000. ThQ1-1. 2000. (Year: 2000).*

File History of *Inter Partes* Review Proceeding No. IPR2014-01166, filed Jul. 15, 2014; 2822 pages.

File History of *Inter Partes* Review Proceeding No. IPR2014-01276, filed Aug. 12, 2014; 2971 pages.

File History of *Inter Partes* Review Proceeding No. IPR2015-00726, filed Feb. 12, 2015; 3879 pages.

File History of *Inter Partes* Review Proceeding No. IPR2015-00727, filed Feb. 12, 2015; 2683 pages.

File History of *Inter Partes* Review Proceeding No. IPR2015-00731, filed Feb. 13, 2015; 3544 pages.

File History of *Inter Partes* Review Proceeding No. IPR2015-00739, filed Feb. 14, 2015; 3750 pages.

File History of *Inter Partes* Review Proceeding No. IPR2015-00816, filed Feb. 26, 2015; 1719 pages.

File History of *Inter Partes* Review Proceeding No. IPR2015-00894, filed Mar. 17, 2015; 1980 pages.

File History of *Inter Partes* Review Proceeding No. IPR2015-01958, filed Sep. 24, 2015; 1778 pages.

File History of *Inter Partes* Review Proceeding No. IPR2015-01961, filed Sep. 24, 2015; 1895 pages.

File History of *Inter Partes* Review Proceeding No. IPR2015-01969, filed Sep. 25, 2015; 1069 pages.

File History of *Inter Partes* Review Proceeding No. IPR2015-01971, filed Sep. 25, 2015; 1275 pages.

File History for U.S. Court of Appeals Case No. 2016-2394, filed Jul. 27, 2016; 4283 pages.

File History for U.S. Supreme Court Case No. 18-314 (appeal of Federal Circuit Case Nos. 2016-2394, 2016-2395, 2017-1105, 2017-1106, 2017-1107, 2017-1108), filed Sep. 6, 2018; 508 pages.

Kurt E. Petersen, Silicon as a Mechanical Material, *Proceedings of the IEEE*, vol. 70, No. 5, 1982; pp. 420-457.

Docket from U.S. District Court Case No. 3-14-cv-03351, filed Jul. 25, 2014; 15 pages.

Docket from U.S. District Court Case No. 3-14-cv-03348, filed Jul. 24, 2014; 22 pages.

Docket from U.S. District Court Case No. 3-14-cv-03349, filed Jul. 24, 2014; 11 pages.

Docket from U.S. District Court Case No. 3-14-cv-03350, filed Jul. 24, 2014; 11 pages.

Docket from U.S. District Court Case No. 1-14-cv-22701, filed Jul. 21, 2014; 2 pages.

Docket from U.S. District Court Case No. 0-14-cv-61629, filed Jul. 15, 2014; 4 pages.

Docket from U.S. District Court Case No. 0-14-cv-60350, filed Feb. 12, 2014; 8 pages.

Docket from U.S. District Court Case No. 1-14-cv-20529, filed Feb. 12, 2014; 9 pages.

Docket from U.S. District Court Case No. 1-14-cv-20530, filed Feb. 12, 2014; 12 pages.

Docket from U.S. District Court Case No. 1-14-cv-20531, filed Feb. 12, 2014; 8 pages.

* cited by examiner

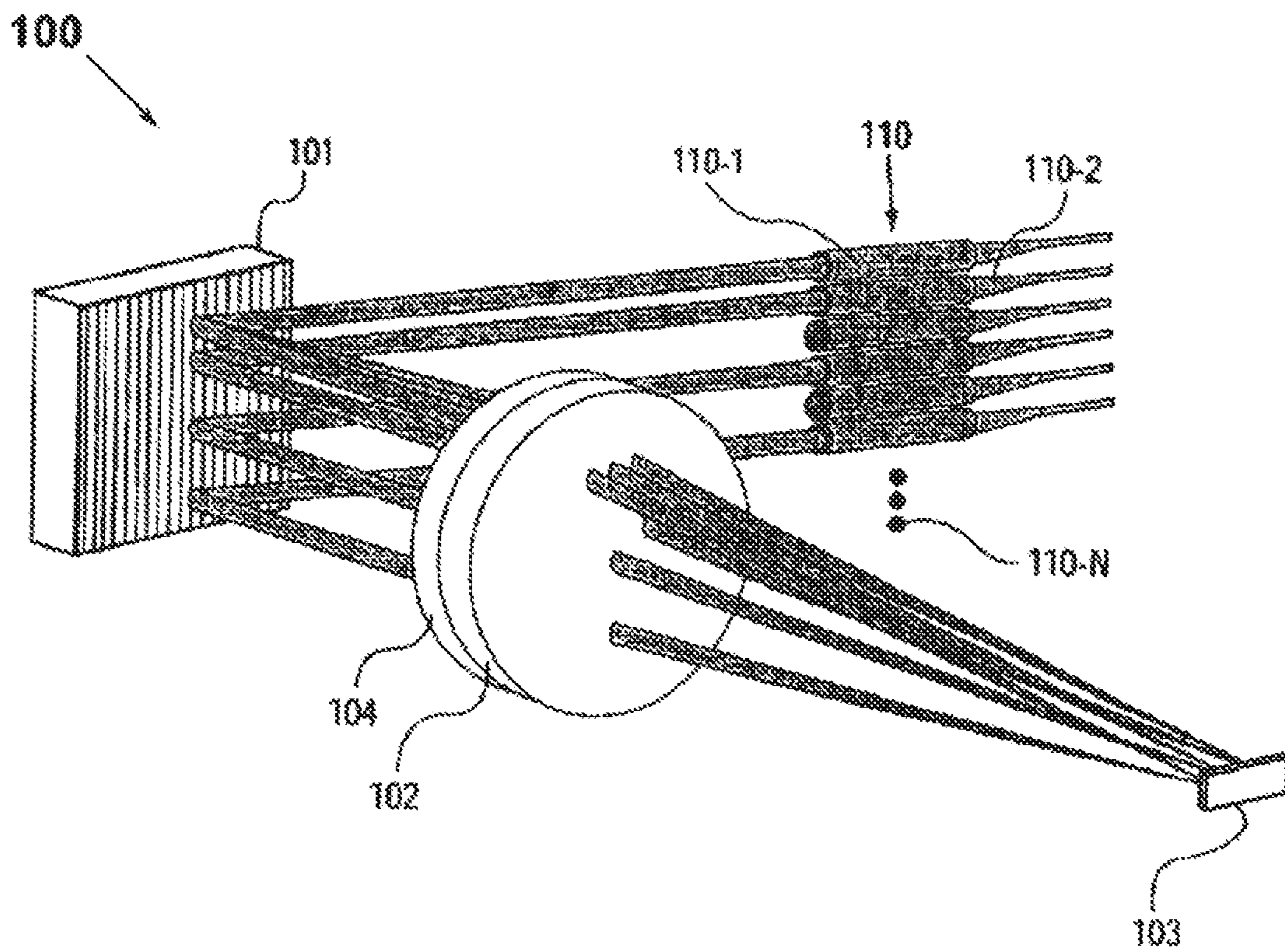

Fig. 1A

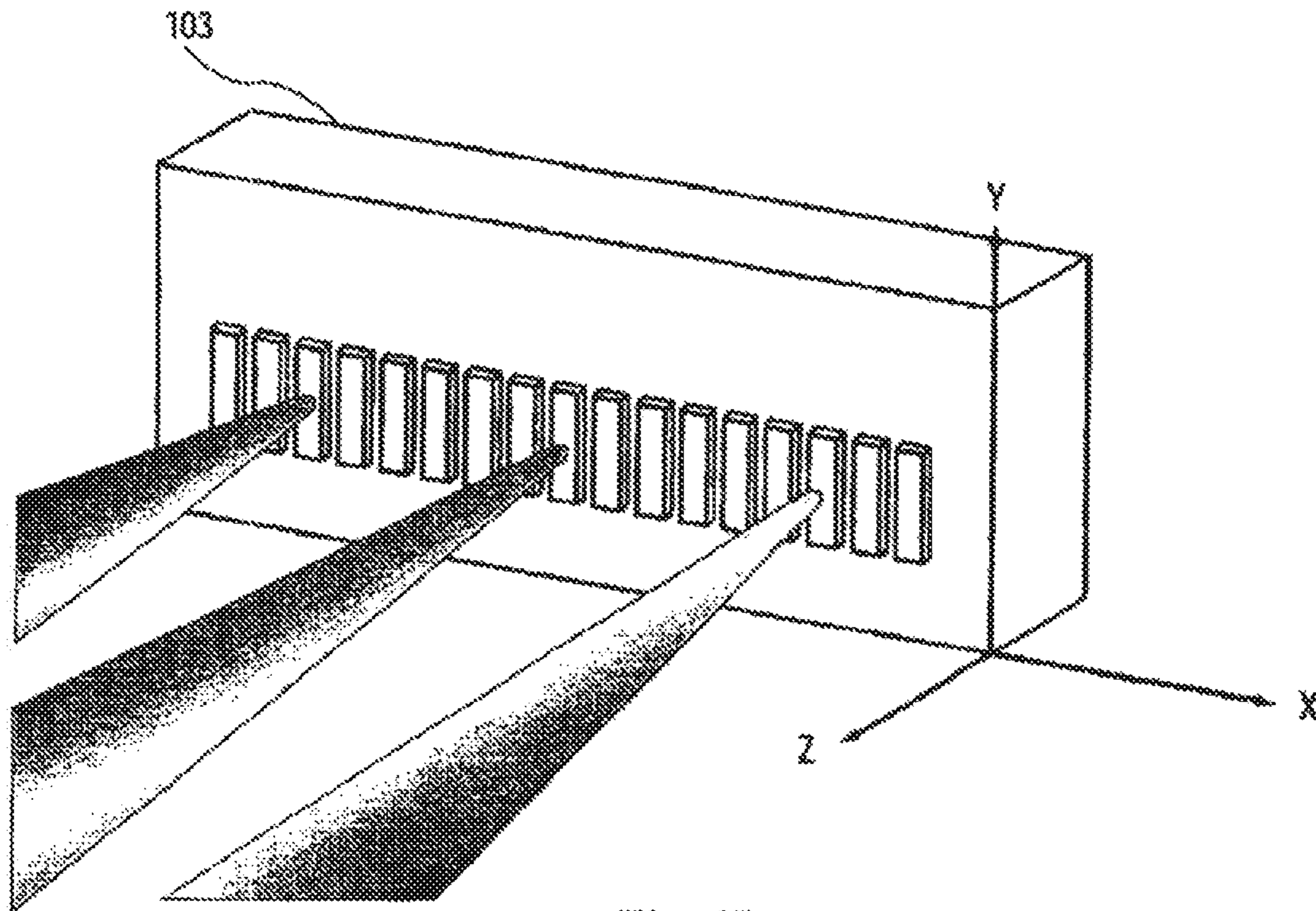
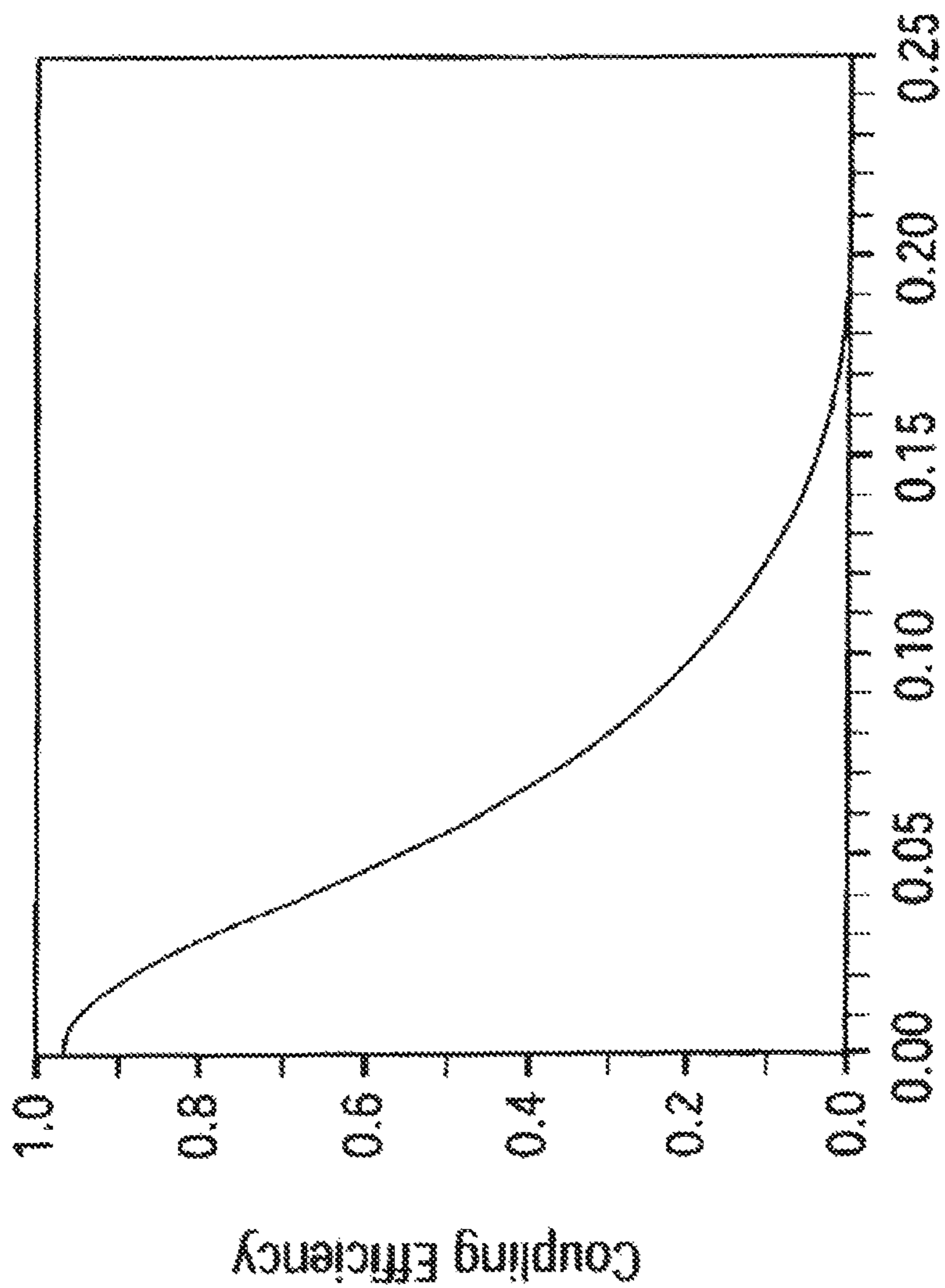

Fig. 1B



Micromirror's Pivoting Angle θ (degree)

Fig. 1C

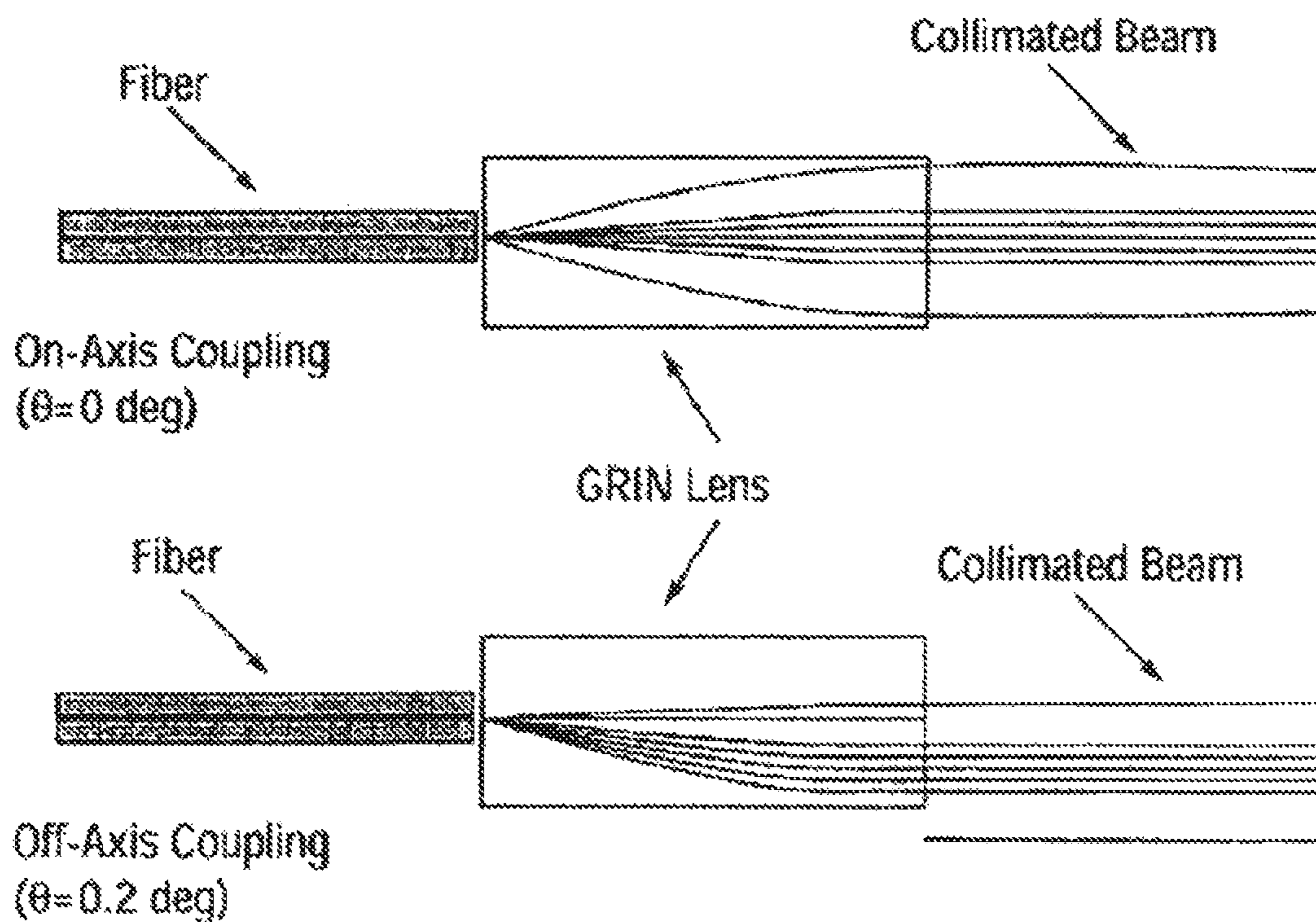

Fig. 1D

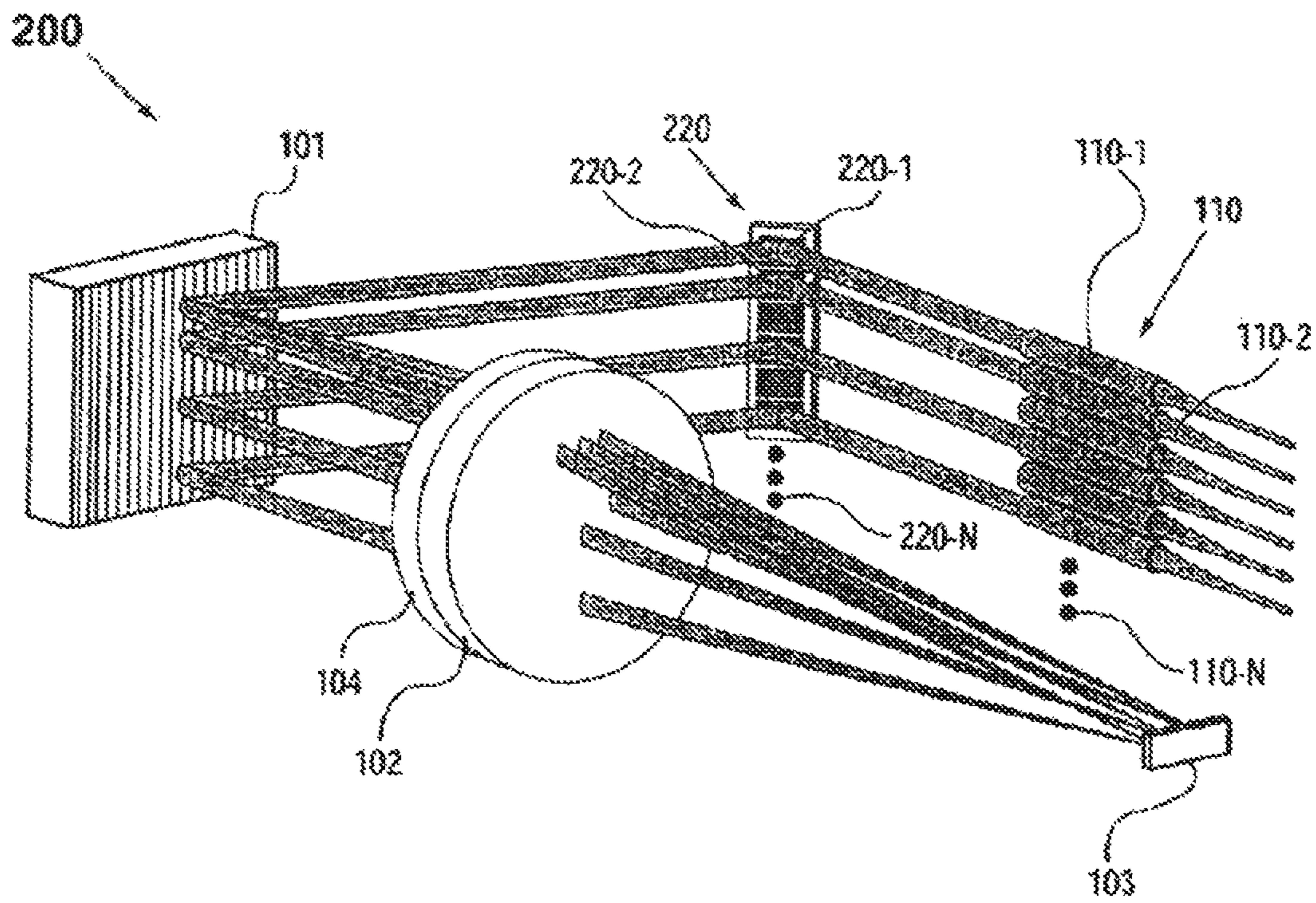

Fig. 2A

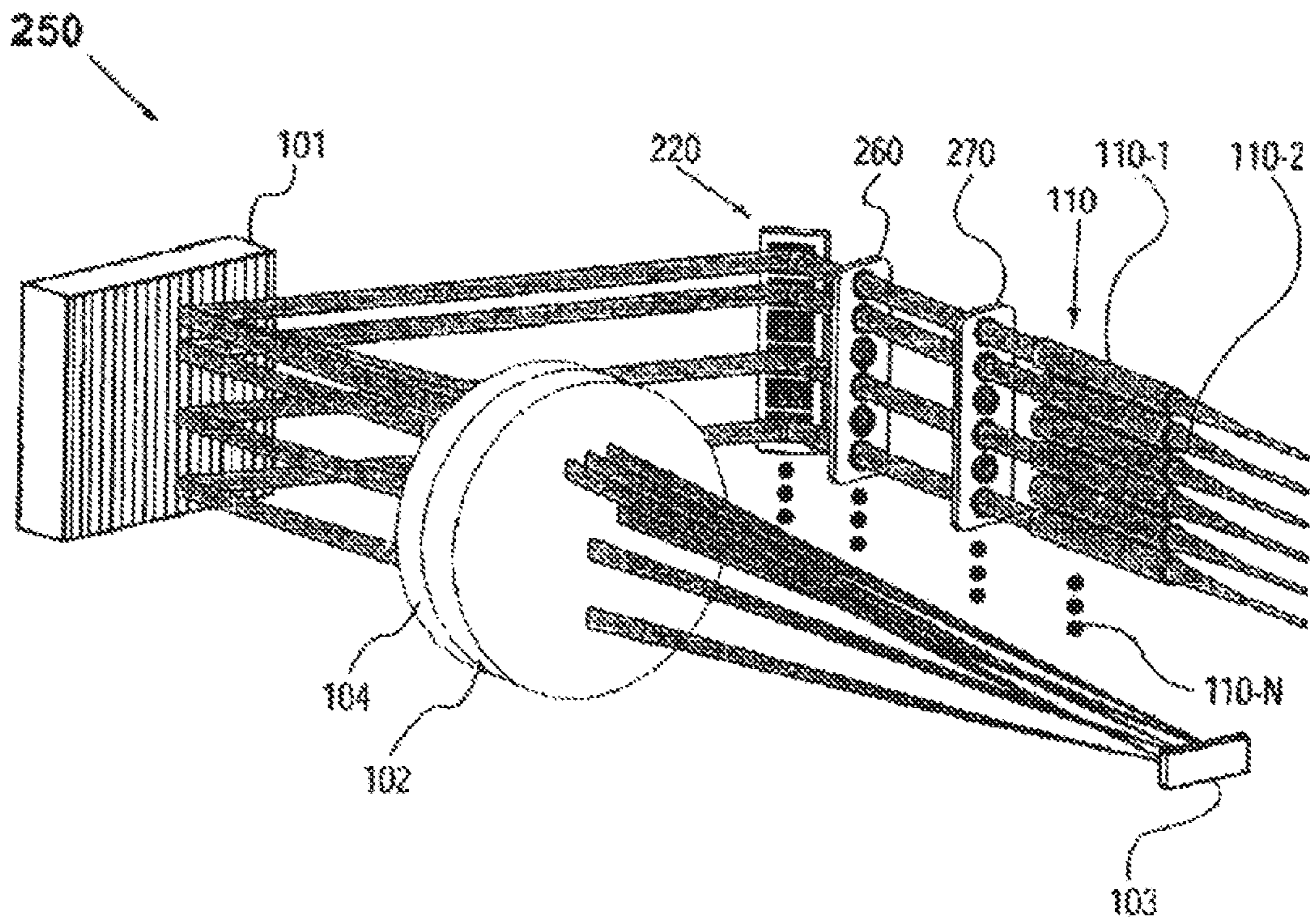

Fig. 2B

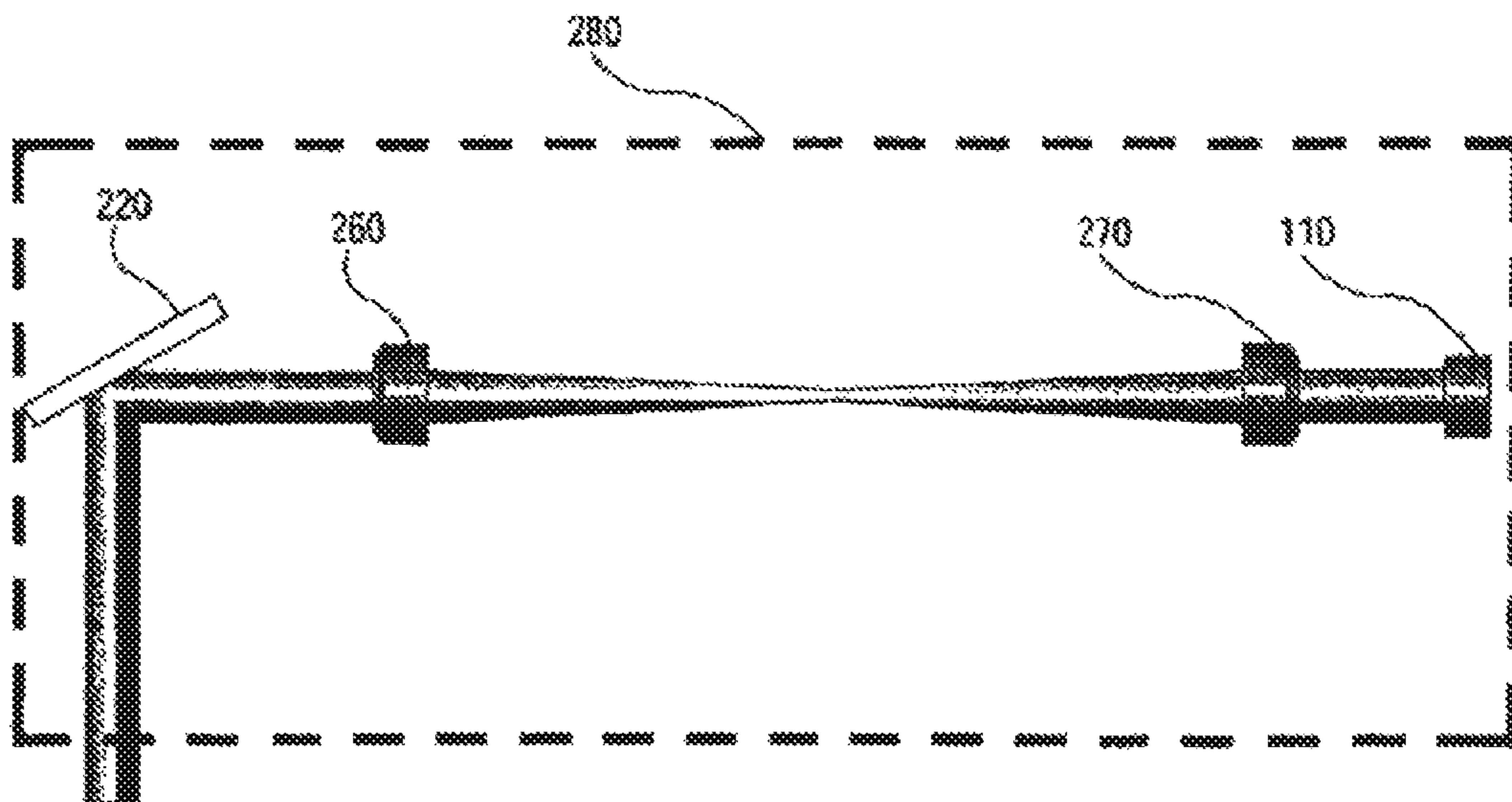

Fig. 2C

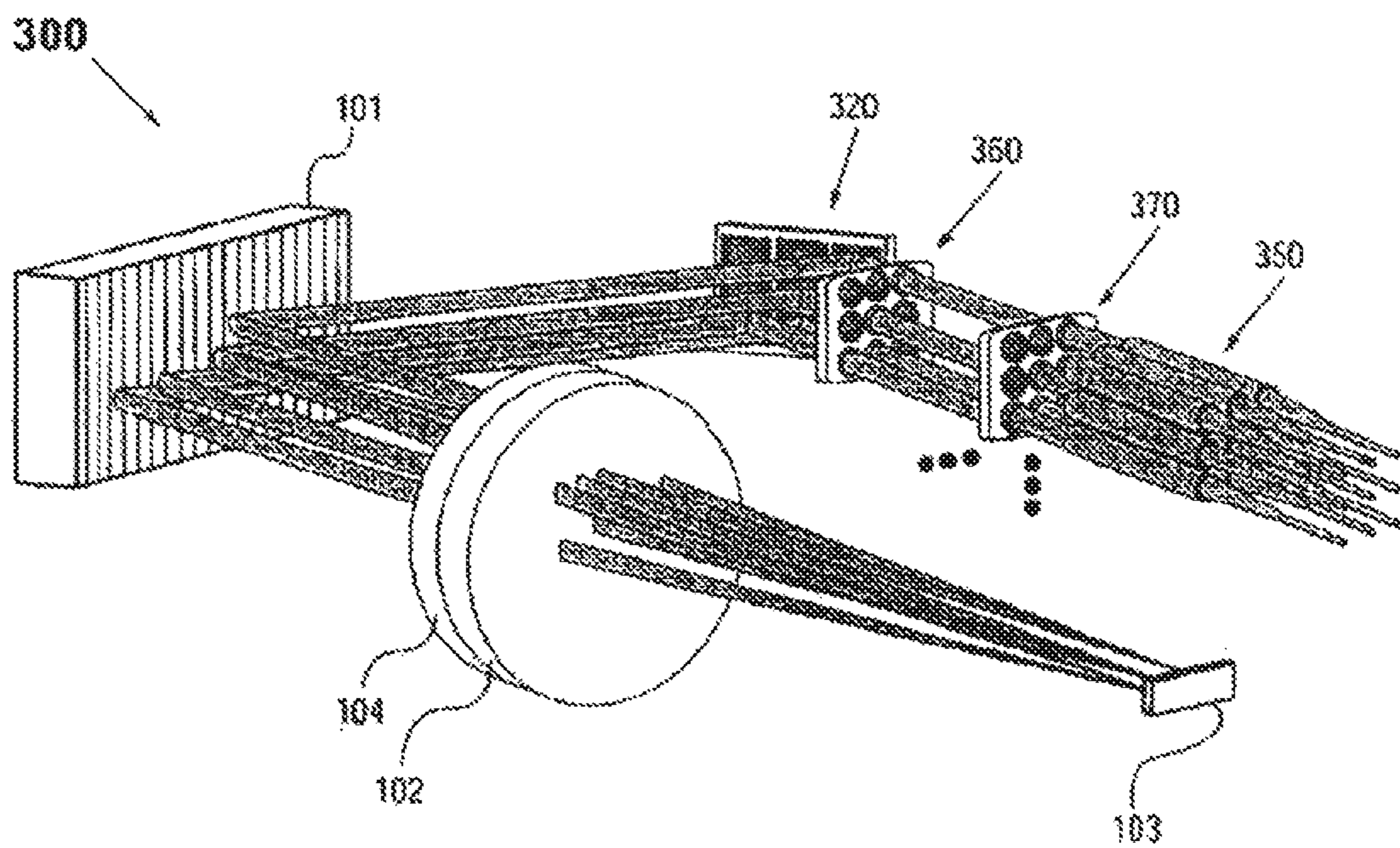

Fig. 3

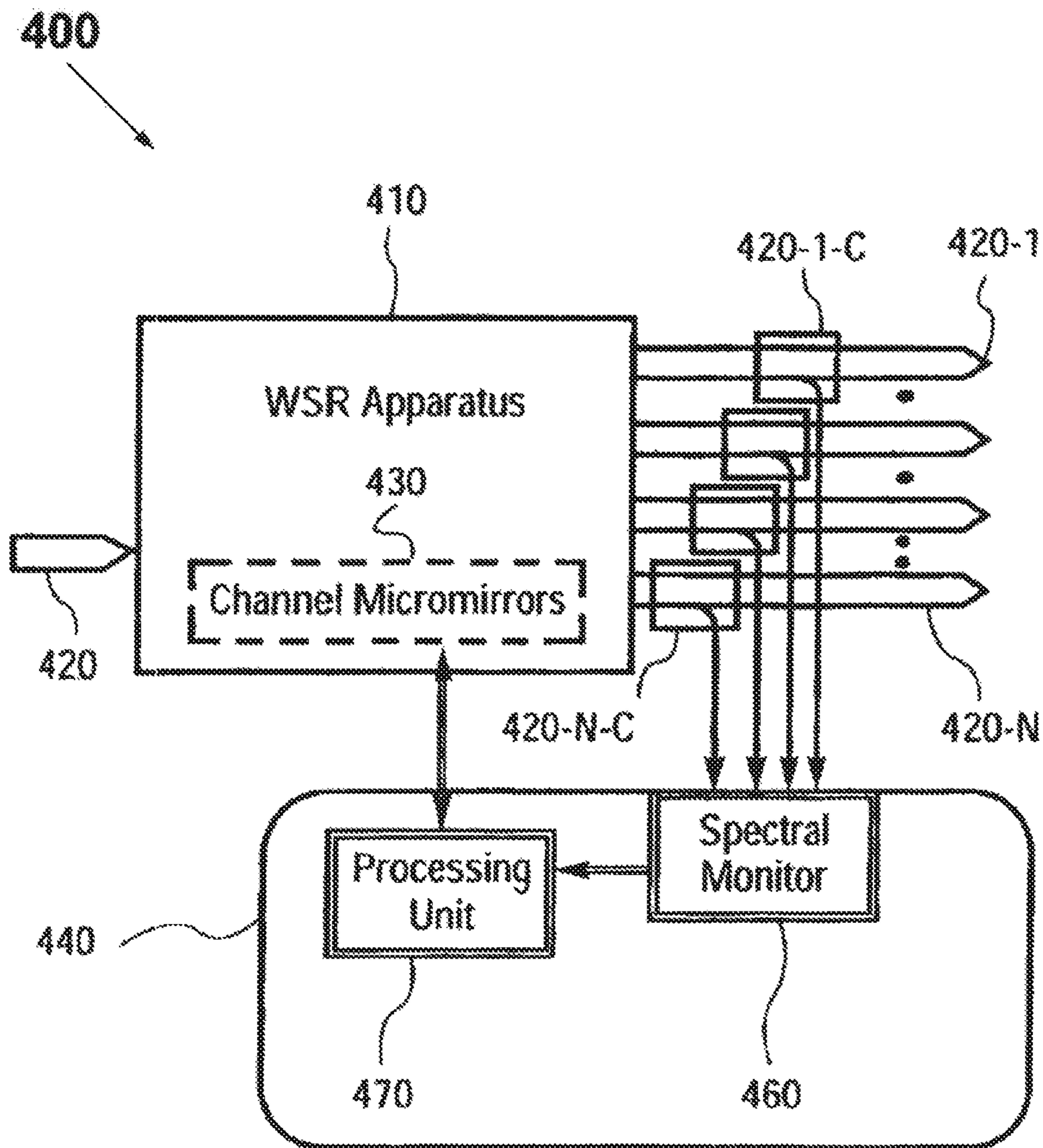

Fig. 4A

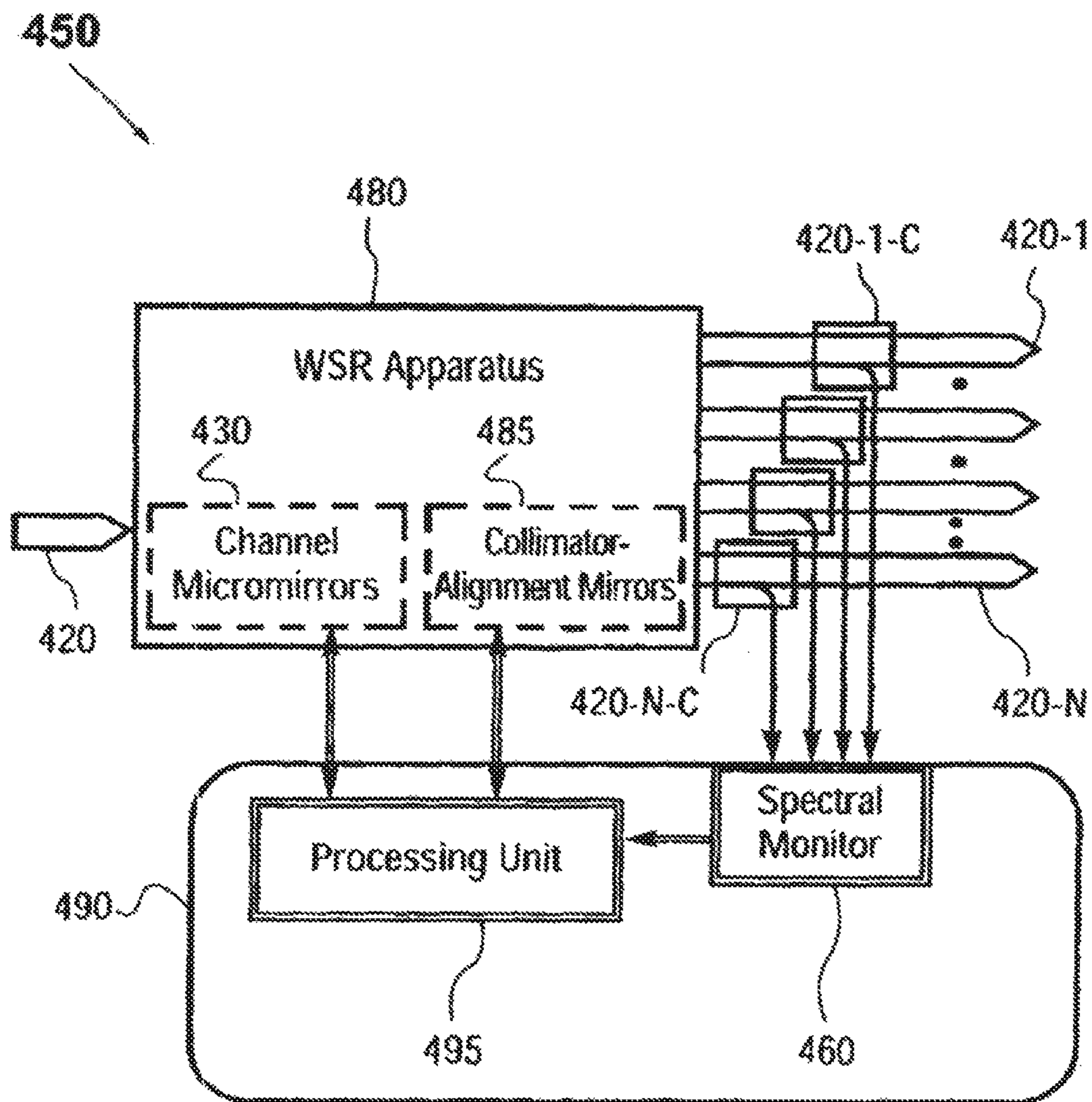

Fig. 4B

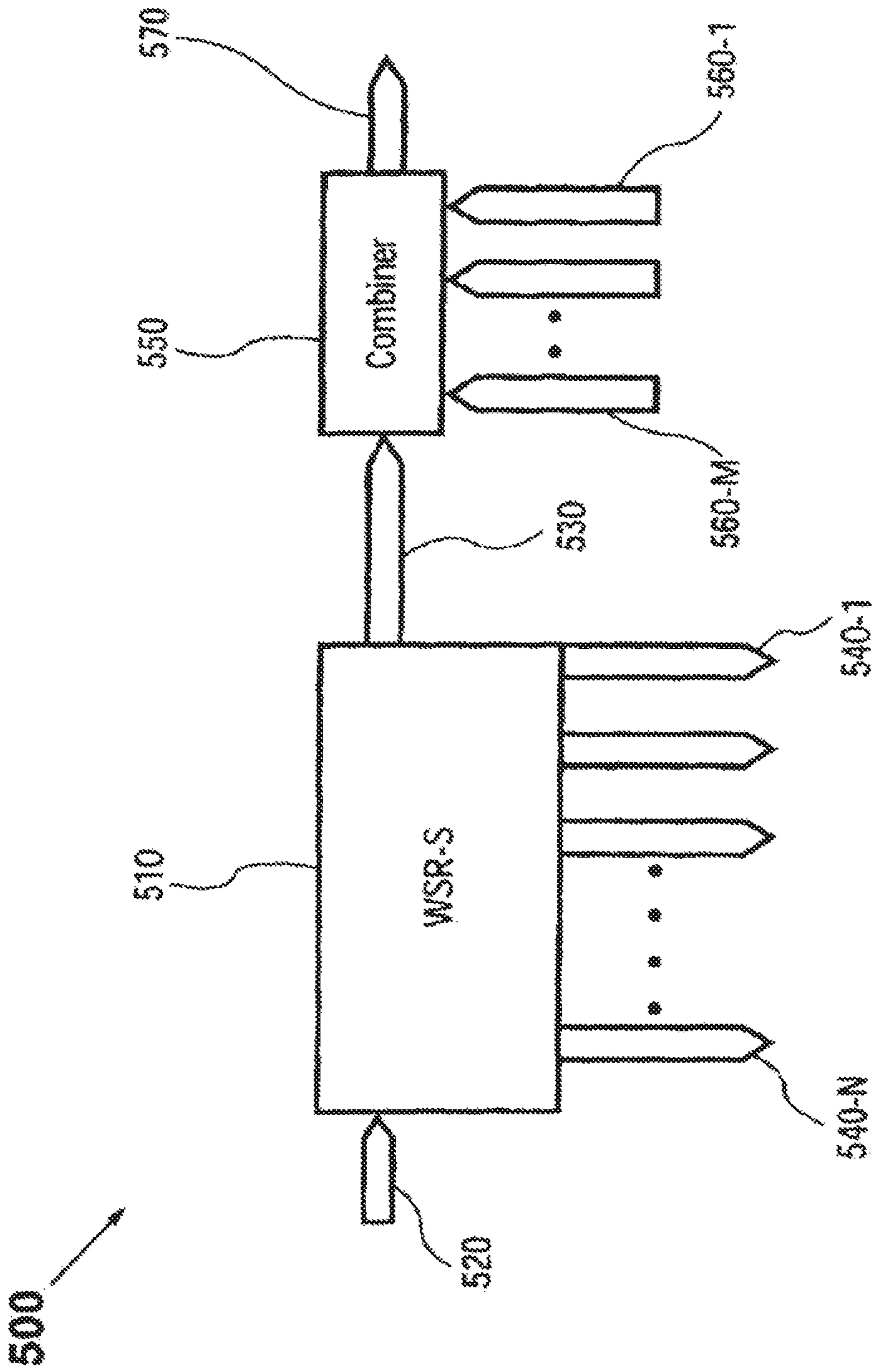

Fig. 5

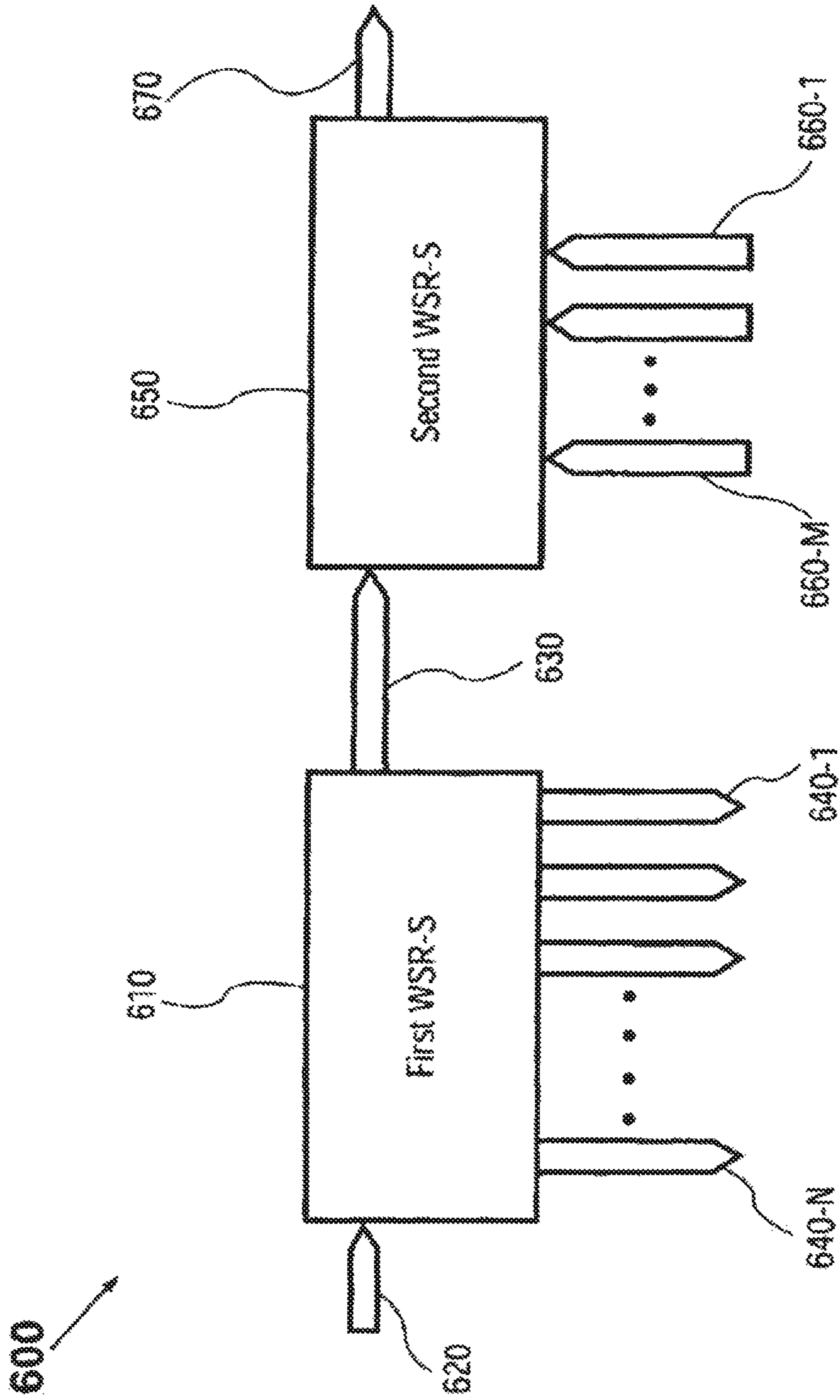

Fig. 6

**RECONFIGURABLE OPTICAL ADD-DROP
MULTIPLEXERS WITH SERVO CONTROL
AND DYNAMIC SPECTRAL POWER
MANAGEMENT CAPABILITIES**

Matter enclosed in heavy brackets [] appears in the original patent but forms no part of the first, second and this reissue specification. Matter enclosed in double heavy brackets [[]] appears in the first reissue patent but forms no part of the second and this third reissue specification. Matter enclosed in triple heavy brackets [[[]]] appears in the second reissue patent but forms no part of this third reissue specification. Matter printed in italics indicates the additions made by the first reissue; matter printed in bold face indicates the additions made by the second reissue; matter printed in bold face italics indicates the additions made by this third reissue; a claim printed with strikethrough indicates that the claim was canceled, disclaimed, or held invalid by a prior post-patent action or proceeding.

This is a reissue of U.S. Reissue Pat. No. RE42,678 (U.S. application Ser. No. 12/815,930 filed Jun. 15, 2010), which is a reissue of U.S. Reissue Pat. No. RE39,397 (U.S. application Ser. No. 11/027,586 filed on Dec. 31, 2004), which is a reissue of U.S. Pat. No. 6,625,346 (U.S. application Ser. No. 09/938,426 filed Sep. 23, 2003).

CROSS-REFERENCE TO RELATED
APPLICATIONS

This application claims priority of U.S. Provisional Patent Application No. 60/277,217, filed Mar. 19, 2001 which is incorporated herein by reference.

FIELD OF THE INVENTION

This invention relates generally to optical communication systems. More specifically, it relates to a novel class of dynamically reconfigurable optical add-drop multiplexers (OADMs) for wavelength division multiplexed optical networking applications.

BACKGROUND

As fiber-optic communication networks rapidly spread into every walk of modern life, there is a growing demand for optical components and subsystems that enable the fiber-optic communications networks to be increasingly scalable, versatile, robust, and cost-effective.

Contemporary fiber-optic communications networks commonly employ wavelength division multiplexing (WDM), for it allows multiple information (or data) channels to be simultaneously transmitted on a single optical fiber by using different wavelengths and thereby significantly enhances the information-bandwidth of the fiber. The prevalence of WDM technology has made optical add-drop multiplexers indispensable building blocks of modern fiber-optic communication networks. An optical add-drop multiplexer (OADM) serves to selectively remove (or drop) one or more wavelengths from a multiplicity of wavelengths on an optical fiber, hence taking away one or more data channels from the traffic stream on the fiber. It further adds one or more wavelength back onto the fiber, thereby inserting new data channels in the same stream of traffic. As such,

an OADM makes it possible to launch and retrieve multiple data channels (each characterized by a distinct wavelength) onto and from an optical fiber respectively, without disrupting the overall traffic flow along the fiber. Indeed, careful placement of the OADMs can dramatically improve an optical communication network's flexibility and robustness, while providing significant cost advantages.

Conventional OADMs in the art typically employ multiplexers/demultiplexers (e.g. waveguide grating routers or arrayed-waveguide gratings), tunable filters, optical switches, and optical circulators in a parallel or serial architecture to accomplish the add and drop functions. In the parallel architecture, as exemplified in U.S. Pat. No. 5,974,207, a demultiplexer (e.g., a waveguide grating router) first separates a multi-wavelength signal into its constituent spectral components. A wavelength switching/routing means (e.g., a combination of optical switches and optical circulators) then serves to drop selective wavelengths and add others. Finally, a multiplexer combines the remaining (i.e., the pass-through) wavelengths into an output multi-wavelength optical signal. In the serial architecture, as exemplified in U.S. Pat. No. 6,205,269, tunable filters (e.g., Bragg fiber gratings) in combination with optical circulators are used to separate the drop wavelength from the pass-through wavelengths and subsequently launch the add channels into the pass-through path. And if multiple wavelengths are to be added and dropped, additional multiplexers and demultiplexers are required to demultiplex the drop wavelengths and multiplex the add wavelengths, respectively. Irrespective of the underlying architecture, the OADMs currently in the art are characteristically high in cost, and prone to significant optical loss accumulation. Moreover, the designs of these OADMs are such that it is inherently difficult to reconfigure them in a dynamic fashion.

U.S. Pat. No. 6,204,946 to Askyuk et al. discloses an OADM that makes use of free-space optics in a parallel construction. In this case, a multi-wavelength optical signal emerging from an input port is incident onto a ruled diffraction grating. The constituent spectral channels thus separated are then focused by a focusing lens onto a linear array of binary micromachined mirrors. Each micromirror is configured to operate between two discrete states, such that it either retrofits its corresponding spectral channel back into the input port as a pass-through channel, or directs its spectral channel to an output port as a drop channel. As such, the pass-through signal (i.e., the combined pass-through channels) shares the same input port as the input signal. An optical circulator is therefore coupled to the input port, to provide necessary routing of these two signals. Likewise, the drop channels share the output port with the add channels. An additional optical circulator is thereby coupled to the output port, from which the drop channels exit and the add channels are introduced into the output ports. The add channels are subsequently combined with the pass-through signal by way of the diffraction grating and the binary micromirrors.

Although the aforementioned OADM disclosed by Askyuk et al. has the advantage of performing wavelength separating and routing in free space and thereby incurring less optical loss, it suffers a number of limitations. First, it requires that the pass-through signal share the same port/fiber as the input signal. An optical circulator therefore has to be implemented, to provide necessary routing of these two signals. Likewise, all the add and drop channels enter and leave the OADM through the same output port, hence the need for another optical circulator. Moreover, additional means must be provided to multiplex the add channels

before entering the system and to demultiplex the drop channels after exiting the system. This additional multiplexing/demultiplexing requirement adds more cost and complexity that can restrict the versatility of the OADM thus-constructed. Second, the optical circulators implemented in this OADM for various routing purposes introduce additional optical losses, which can accumulate to a substantial amount. Third, the constituent optical components must be in a precise alignment, in order for the system to achieve its intended purpose. There are, however, no provisions provided for maintaining the requisite alignment; and no mechanisms implemented for overcoming degradation in the alignment owing to environmental effects such as thermal and mechanical disturbances over the course of operation.

U.S. Pat. No. 5,906,133 to Tomlinson discloses an OADM that makes use of a design similar to that of Aksyuk et al. There are input, output, drop and add ports implemented in this case. By positioning the four ports in a specific arrangement, each micromirror, notwithstanding switchable between two discrete positions, either reflects its corresponding channel (coming from the input port) to the output port, or concomitantly reflects its channel to the drop port and an incident add channel to the output port. As such, this OADM is able to perform both the add and drop functions without involving additional optical components (such as optical circulators and in the system of the Aksyuk et al.). However, because a single drop port is designated for all the drop channels and a single add port is designated for all the add channels, the add channels would have to be multiplexed before entering the add port and the drop channels likewise need to be demultiplexed upon exiting from the drop port. Moreover, as in the case of Aksyuk et al., there are no provisions provided for maintaining requisite optical alignment in the system, and no mechanisms implemented for combating degradation in the alignment due to environmental effects over the course of operation.

As such, the prevailing drawbacks suffered by the OADMs currently in the art are summarized as follows:

- 1) The wavelength routing is intrinsically static, rendering it difficult to dynamically reconfigure these OADMs.
- 2) Add and/or drop channels often need to be multiplexed and/or demultiplexed, thereby imposing additional complexity and cost.
- 3) Stringent fabrication tolerance and painstaking optical alignments are required. Moreover, the optical alignment is not actively maintained, rendering it susceptible to environmental effects such as thermal and mechanical disturbances over the course of operation.
- 4) In an optical communication network, OADMs are typically in a ring or cascaded configuration. In order to mitigate the interference amongst OADMs, which often adversely affects the overall performance of the network, it is essential that the power levels of spectral channels entering and exiting each OADM be managed in a systematic way, for instance, by introducing power (or gain) equalization at each stage. Such a power equalization capability is also needed for compensating for nonuniform gain caused by optical amplifiers (e.g., erbium doped fiber amplifiers) in the network. There lacks, however, a systematic and dynamic management of the power levels of various spectral channels in these OADMs.
- 5) The inherent high cost and heavy optical loss further impede the wide application of these OADMs.

In view of the foregoing, there is an urgent need in the art for optical add-drop multiplexers that overcome the aforementioned shortcomings, in a simple, effective, and economical construction.

SUMMARY

The present invention provides a wavelength-separating-routing (WSR) apparatus and method which employ an array of fiber collimators serving as an input port and a plurality of output ports; a wavelength-separator; a beam-focuser; and an array of channel micromirrors.

In operation, a multi-wavelength optical signal emerges from the input port. The wavelength-separator separates the multi-wavelength optical signal into multiple spectral channels, each characterized by a distinct center wavelength and associated bandwidth. The beam-focuser focuses the spectral channels into corresponding spectral spots. The channel micromirrors are positioned such that each channel micromirror receives one of the spectral channels. The channel micromirrors are individually controllable and movable, e.g., continuously pivotable (or rotatable), so as to reflect the spectral channels into selected ones of the output ports. As such, each channel micromirror is assigned to a specific spectral channel, hence the name "channel micromirror". And each output port may receive any number of the reflected spectral channels.

A distinct feature of the channel micromirrors in the present invention, in contrast to those used in the prior art, is that the motion, e.g., pivoting (or rotation), of each channel micromirror is under analog control such that its pivoting angle can be continuously adjusted. This enables each channel micromirror to scan its corresponding spectral channel across all possible output ports and thereby direct the spectral channel to any desired output ports.

In the WSR apparatus of the present invention, the wavelength-separator may be provided by a ruled diffraction grating, a holographic diffraction grating, an echelle grating, a curved diffraction grating, a dispersing prism, or other wavelength-separating means known in the art. The beam-focuser may be a single lens, an assembly of lenses, or other beam-focusing means known in the art. The channel micromirrors may be provided by silicon micromachined mirrors, reflective ribbons (or membranes), or other types of beam-deflecting means known in the art. And each channel micromirror may be pivotable about one or two axes. The fiber collimators serving as the input and output ports may be arranged in a one-dimensional or two-dimensional array. In the latter case, the channel micromirrors must be pivotable biaxially.

The WSR apparatus of the present invention may further comprise an array of collimator-alignment mirrors, in optical communication with the wavelength-separator and the fiber collimators, for adjusting the alignment of the input multi-wavelength signal and directing the spectral channels into the selected output ports by way of angular control of the collimated beams. Each collimator-alignment mirror may be rotatable about one or two axes. The collimator-alignment mirrors may be arranged in a one-dimensional or two-dimensional array. First and second arrays of imaging lenses may additionally be optically interposed between the collimator-alignment mirrors and the fiber collimators in a telecentric arrangement, thereby "imaging" the collimator-alignment mirrors onto the corresponding fiber collimators to ensure an optimal alignment.

The WSR apparatus of the present invention may further include a servo-control assembly, in communication with

the channel micromirrors and the output ports. The servo-control assembly serves to monitor the power levels of the spectral channels coupled into the output ports and further provide control of the channel micromirrors on an individual basis, so as to maintain a predetermined coupling efficiency of each spectral channel in one of the output ports. As such, the servo-control assembly provides dynamic control of the coupling of the spectral channels into the respective output ports and actively manages the power levels of the spectral channels coupling into the output ports. (If the WSR apparatus includes an array of collimator-alignment mirrors as described above, the servo-control assembly may additionally provide dynamic control of the collimator-alignment mirrors.) Moreover, the utilization of such a servo-control assembly effectively relaxes the requisite fabrication tolerances and the precision of optical alignment during assembly of a WSR apparatus of the present invention, and further enables the system to correct for shift in optical alignment over the course of operation. A WSR apparatus incorporating a servo-control assembly thus described is termed a WSR-S apparatus, hereinafter in the present invention.

Accordingly, the WSR-S (or WSR) apparatus of the present invention may be used to construct a variety of optical devices, including a novel class of dynamically reconfigurable optical add-drop multiplexers (OADMs), as exemplified in the following embodiments.

One embodiment of an OADM of the present invention comprises an aforementioned WSR-S (or WSR) apparatus and an optical combiner. The output ports of the WSR-S apparatus include a pass-through port and one or more drop ports, each carrying any number of the spectral channels. The optical combiner is coupled to the pass-through port, serving to combine the pass-through channels with one or more add spectral channels. The combined optical signal constitutes an output signal of the system. The optical combiner may be an $N \times 1$ ($N \leq 2$) broadband fiber-optic coupler, for instance, which also serves the purpose of multiplexing a multiplicity of add spectral channels to be coupled into the system.

In another embodiment of an OADM of the present invention, a first WSR-S (or WSR) apparatus is cascaded with a second WSR-S (or WSR) apparatus. The output ports of the first WSR-S (or WSR) apparatus include a pass-through port and one or more drop ports. The second WSR-S (or WSR) apparatus includes a plurality of input ports and an exiting port. The configuration is such that the pass-through channels from the first WSR-S apparatus and one or more add channels are directed into the input ports of the second WSR-S apparatus, and consequently multiplexed into an output multi-wavelength optical signal directed into the exiting port of the second WSR-S apparatus. That is to say that in this embodiment, one WSR-S apparatus (e.g., the first one) effectively performs a dynamic drop function, whereas the other WSR-S apparatus (e.g., the second one) carries out a dynamic add function. And there are essentially no fundamental restrictions on the wavelengths that can be added or dropped, other than those imposed by the overall communication system. Moreover, the underlying OADM architecture thus presented is intrinsically scalable and can be readily extended to any number of the WSR-S (or WSR) systems, if so desired for performing intricate add and drop functions in a network environment.

Those skilled in the art will recognize that the aforementioned embodiments provide only two of many embodiments of a dynamically reconfigurable OADM according to the present invention. Various changes, substitutions, and alternations can be made herein, without departing from the

principles and the scope of the invention. Accordingly, a skilled artisan can design an OADM in accordance with the present invention, to best suit a given application.

All in all, the OADMs of the present invention provide many advantages over the prior art devices, notably:

- 1) By advantageously employing an array of channel micromirrors that are individually and continuously controllable, an OADM of the present invention is capable of routing the spectral channels on a channel-by-channel basis and directing any spectral channel into any one of the output ports. As such, its underlying operation is dynamically reconfigurable, and its underlying architecture is intrinsically scalable to a large number of channel counts.
- 2) The add and drop spectral channels need not be multiplexed and demultiplexed before entering and after leaving the OADM respectively. And there are not fundamental restrictions on the wavelengths to be added or dropped.
- 3) The coupling of the spectral channels into the output ports is dynamically controlled by a servo-control assembly, rendering the OADM less susceptible to environmental effects (such as thermal and mechanical disturbances) and therefore more robust in performance. By maintaining an optimal optical alignment, the optical losses incurred by the spectral channels are also significantly reduced.
- 4) The power levels of the spectral channels coupled into the output ports can be dynamically managed according to demand, or maintained at desired values (e.g., equalized at a predetermined value) by way of the servo-control assembly. This spectral power-management capability as an integral part of the OADM will be particularly desirable in WDM optical networking applications.
- 5) The use of free-space optics provides a simple, low loss, and cost-effective construction. Moreover, the utilization of the servo-control assembly effectively relaxes the requisite fabrication tolerances and the precision of optical alignment during initial assembly, enabling the OADM to be simpler and more adaptable in structure, lower in cost and optical loss.
- 6) The underlying OADM architecture allows a multiplicity of the OADMs according to the present invention to be readily assembled (e.g., cascaded) for WDM optical networking applications.

The novel features of this invention, as well as the invention itself, will be best understood from the following drawings and detailed description.

BRIEF DESCRIPTION OF THE FIGURES

FIGS. 1A-1D show a first embodiment of a wavelength-separating-routing (WSR) apparatus according to the present invention, and the modeling results demonstrating the performance of the WSR apparatus;

FIGS. 2A-2C depict second and third embodiments of a WSR apparatus according to the present invention;

FIG. 3 shows a fourth embodiment of a WSR apparatus according to the present invention;

FIGS. 4A-4B show schematic illustration of two embodiments of a WSR-S apparatus comprising a WSR apparatus and a servo-control assembly, according to the present invention;

FIG. 5 depicts an exemplary embodiment of an optical add-drop multiplexer (OADM) according to the present invention; and

FIG. 6 shows an alternative embodiment of an OADM according to the present invention.

DETAILED DESCRIPTION

In this specification and appending claims, a “spectral channel” is characterized by a distinct center wavelength and associated bandwidth. Each spectral channel may carry a unique information signal, as in WDM optical networking applications.

FIG. 1A depicts a first embodiment of a wavelength-separating-routing (WSR) apparatus according to the present invention. By way of example to illustrate the general principles and the topological structure of a wavelength-separating-routing (WSR) apparatus of the present invention, the WSR apparatus 100 comprises multiple input/output ports which may be in the form of an array of fiber collimators 110, providing an input port 110-1 and a plurality of output ports 110-2 through 110-N ($N \leq 3$); a wavelength-separator which in one form may be a diffraction grating 101; a beam-focuser in the form of a focusing lens 102; and an array of channel micromirrors 103.

In operation, a multi-wavelength optical signal emerges from the input port 110-1. The diffraction grating 101 angularly separates the multi-wavelength optical signal into multiple spectral channels, which are in turn focused by the focusing lens 102 into a spatial array of distinct spectral spots (not shown in FIG. 1A) in a one-to-one correspondence. The channel micromirrors 103 are positioned in accordance with the spatial array formed by the spectral spots, such that each channel micromirror receives one of the spectral channels. The channel micromirrors 103 are individually controllable and movable, e.g., pivotable (or rotatable) under analog (or continuous) control, such that, upon reflection, the spectral channels are directed into selected ones of the output ports 110-2 through 110-N by way of the focusing lens 102 and the diffraction grating 101. As such, each channel micromirror is assigned to a specific spectral channel, hence the name “channel micromirror”. Each output port may receive any number of the reflected spectral channels.

For purposes of illustration and clarity, only a selective few (e.g., three) of the spectral channels, along with the input multi-wavelength optical signal, are graphically illustrated in FIG. 1A and the following figures. It should be noted, however, that there can be any number of the spectral channels in a WSR apparatus of the present invention (so long as the number of spectral channels does not exceed the number of channel mirrors employed in the system). It should also be noted that the optical beams representing the spectral channels shown in FIG. 1A and the following figures are provided for illustrative purpose only. That is, their sizes and shapes may not be drawn according to scale. For instance, the input beam and the corresponding diffracted beams generally have different cross-sectional shapes, so long as the angle of incidence upon the diffraction grating is not equal to the angle of diffraction, as is known to those skilled in the art.

In the embodiment of FIG. 1A, it is preferable that the diffracting grating 101 and the channel micromirrors 103 are placed respectively at the first and second (i.e., the front and back) focal points (on the opposing sides) of the focusing lens 102. Such a telecentric arrangement allows the chief rays of the focused beams to be parallel to each other and generally parallel to the optical axis. In this application, the telecentric configuration further allows the reflected spectral channels to be efficiently coupled into the respective output

ports, thereby minimizing various translational walk-off effects that may otherwise arise. Moreover, the input multi-wavelength optical signal is preferably collimated and circular in cross-section. The corresponding spectral channels diffracted from the diffraction grating 101 are generally elliptical in cross-section; they may be of the same size as the input beam in one dimension and elongated in the other dimension.

It is known that the diffraction efficiency of a diffraction grating is generally polarization-dependent. That is, the diffraction efficiency of a grating in a standard mounting configuration may be considerably higher for P-polarization that is perpendicular to the groove lines on the grating than for S-polarization that is orthogonal to P-polarization, especially as the number of groove lines (per unit length) increases. To mitigate such polarization-sensitive effects, a quarter-wave plate 104 may be optically interposed between the diffraction grating 101 and the channel micromirrors 103, and preferably placed between the diffraction grating 101 and the focusing lens 102 as is shown in FIG. 1A. In this way, each spectral channel experiences a total of approximately 90-degree rotation in polarization upon traversing the quarter-wave plate 104 twice. (That is, if a beam of light has P-polarization with first encountering the diffraction grating, it would have predominantly (if not all) S-polarization upon the second encountering, and vice versa.) This ensures that all the spectral channels incur nearly the same amount of round-trip polarization dependent loss.

In the WSR apparatus 100 of FIG. 1A, the diffraction grating 101, by way of example, is oriented such that the focused spots of the spectral channels fall onto the channel micromirrors 103 in a horizontal array, as illustrated in FIG. 1B.

Depicted in FIG. 1B is a close-up view of the channel micromirrors 103 shown in the embodiment of FIG. 1A. By way of example, the channel micromirrors 103 are arranged in a one-dimensional array along the x-axis (i.e., the horizontal direction in the figure), so as to receive the focused spots of the spatially separated spectral channels in a one-to-one correspondence. (As in the case of FIG. 1A, only three spectral channels are illustrated, each represented by a converging beam.) Let the reflective surface of each channel micromirror lie in the x-y plane as defined in the figure and be movable, e.g., pivotable (or deflectable) about the x-axis in an analog (or continuous) manner. Each spectral channel, upon reflection, is deflected in the y-direction (e.g., downward) relative to its incident direction, so to be directed into one of the output ports 110-2 through 110-N shown in FIG. 1A.

As described above, a unique feature of the present invention is that the motion of each channel micromirror is individually and continuously controllable, such that its position, e.g., pivoting angle, can be continuously adjusted. This enables each channel micromirror to scan its corresponding spectral channel across all possible output ports and thereby direct the spectral channel to any desired output port. To illustrate this capability, FIG. 1C shows a plot of coupling efficiency as a function of a channel micromirror’s pivoting angle θ , provided by a ray-tracing model of a WSR apparatus in the embodiment of FIG. 1A. As used herein, the coupling efficiency for a spectral channel is defined as the ratio of the amount of optical power coupled into the fiber core in an output port to the total amount of optical power incident upon the entrance surface of the fiber (associated with the fiber collimator grating serving as the output port). In the ray-tracing model, the input optical signal is incident upon a diffraction grating with 700 lines per millimeter at a

grazing angle of 85 degrees, where the grating is blazed to optimize the diffraction efficiency for the “-1” order. The focusing lens has a focal length of 100 mm. Each output port is provided by a quarter-pitch GRIN lens (2 mm in diameter) coupled to an optical fiber (see FIG. 1D). As displayed in FIG. 1C, the coupling efficiency varies with the pivoting angle θ , and it requires about a 0.2-degree change in θ for the coupling efficiency to become practically negligible in this exemplary case. As such, each spectral channel may practically acquire any coupling efficiency value by way of controlling the pivoting angle of its corresponding channel micromirror. This is also to say that variable optical attenuation at the granularity of a single wavelength can be obtained in a WSR apparatus of the present invention. FIG. 1D provides ray-tracing illustrations of two extreme points on the coupling efficiency vs. θ curve of FIG. 1C; on-axis coupling corresponding to $\theta=0$, where the coupling efficiency is maximum; and off-axis coupling corresponding to $\theta=0.2$ degrees, where the representative collimated beam (representing an exemplary spectral channel) undergoes a significant translational walk-off and renders the coupling efficiency practically negligible. All in all, the exemplary modeling results thus described demonstrate the unique capabilities of the WSR apparatus of the present invention.

FIG. 1A provides one of many embodiments of a WSR apparatus according to the present invention. In general, the wavelength-separator is a wavelength-separating means that may be a ruled diffraction grating, a holographic diffraction grating, an echelle grating, a dispersing prism, or other types of spectral-separating means known in the art. The beam-focuser may be a focusing lens, an assembly of lenses, or other beam-focusing means known in the art. The focusing function may also be accomplished by using a curved diffraction grating as the wavelength-separator. The channel micromirrors may be provided by silicon micromachined mirrors, reflective ribbons (or membranes), or other types of beam-deflecting elements known in the art. And each micromirror may be pivoted about one or two axes. What is important is that the pivoting (or rotational) motion of each channel micromirror be individually controllable in an analog manner, whereby the pivoting angle can be continuously adjusted so as to enable the channel micromirror to scan a spectral channel across all possible output ports. The underlying fabrication techniques for micromachined mirrors and associated actuation mechanism are well documented in the art, see U.S. Pat. No. 5,629,790 for example. Moreover, a fiber collimator is typically in the form of a collimating lens (such as a GRIN lens) and a ferrule-mounted fiber packaged together in a mechanically rigid stainless steel (or glass) tube. The fiber collimators serving as the input and output ports may be arranged in a one-dimensional array, a two-dimensional array, or other desired spatial pattern. For instance, they may be conveniently mounted in a linear array along a V-groove fabricated on a substrate made of silicon, plastic, or ceramic, as commonly practiced in the art. It should be noted, however, that the input port and the output ports need not necessarily be in close spatial proximity with each other, such as in an array configuration (although a close packing would reduce the rotational range required for each channel micromirror). Those skilled in the art will know how to design a WSR apparatus according to the present invention, to best suit a given application.

A WSR apparatus of the present invention may further comprise an array of collimator-alignment mirrors, for adjusting the alignment of the input multi-wavelength opti-

cal signal and facilitating the coupling of the spectral channels into the respective output ports, as shown in FIGS. 2A-2B and 3.

Depicted in FIG. 2A is a second embodiment of a WSR apparatus according to the present invention. By way of example, WSR apparatus 200 is built upon and hence shares a number of the elements used in the embodiment of FIG. 1A, as identified by those labeled with identical numerals. Moreover, a one-dimensional array 220 of collimator-alignment mirrors 220-1 through 220-N is optically interposed between the diffraction grating 101 and the fiber collimator array 110. The collimator-alignment mirror 220-1 is designated to correspond with the input port 110-1, for adjusting the alignment of the input multi-wavelength optical signal and therefore ensuring that the spectral channels impinge onto the corresponding channel micromirrors. The collimator-alignment mirrors 220-2 through 220-N are designated to the output ports 110-2 through 110-N in a one-to-one correspondence, serving to provide angular control of the collimator beams of the reflected spectral channels and thereby facilitating the coupling of the spectral channels into the respective output ports according to desired coupling efficiencies. Each collimator-alignment mirror may be rotatable about one axis, or two axes.

The embodiment of FIG. 2A is attractive in applications where the fiber collimators (serving as the input and output ports) are desired to be placed in close proximity to the collimator-alignment mirror array 220. To best facilitate the coupling of the spectral channels into the output ports, arrays of imaging lenses may be implemented between the collimator-alignment mirror array 220 and the fiber collimator array 110, as depicted in FIG. 2B. By way of example, WSR apparatus 250 of FIG. 2B is built upon and hence shares many of the elements used in the embodiment of FIG. 2A, as identified by those labeled with identical numerals. Additionally, first and second arrays 260, 270 of imaging lenses are placed in a 4-f telecentric arrangement with respect to the collimator-alignment mirror array 220 and the fiber collimator array 110. The dashed box 280 shown in FIG. 2C provides a top view of such a telecentric arrangement. In this case, the imaging lenses in the first and second arrays 260, 270 all have the same focal length f . The collimator-alignment mirrors 220-1 through 220-N are placed at the respective first (or front) focal points of the imaging lenses in the first array 260. Likewise, the fiber collimators 110-1 through 110-N are placed at the respective second (or back) focal points of the imaging lenses in the second array 270. And the separation between the first and second arrays 260, 270 of imaging lenses is $2f$. In this way, the collimator-alignment mirrors 220-1 through 220-N are effectively imaged onto the respective entrance surfaces (i.e., the front focal planes) of the GRIN lenses in the corresponding fiber collimators 110-1 through 110-N. Such a telecentric imaging system substantially eliminates translational walk-off of the collimated beams at the output ports that may otherwise occur as the mirror angles change.

FIG. 3 shows a fourth embodiment of a WSR apparatus according to the present invention. By way of example, WSR apparatus 300 is built upon and hence shares a number of the elements used in the embodiment of FIG. 2B, as identified by those labeled with identical numerals. In this case, the one-dimensional fiber collimator array 110 of FIG. 2B is replaced by a two-dimensional array 350 of fiber collimators, providing for an input-port and a plurality of output ports. Accordingly, the one-dimensional collimator-alignment mirror array 220 of FIG. 2B is replaced by a two-dimensional array 320 of collimator-alignment mirrors,

and first and second one-dimensional arrays 260, 270 of imaging lenses of FIG. 2B are likewise replaced by first and second two-dimensional arrays 360, 370 of imaging lenses respectively. As in the case of the embodiment of FIG. 2B, the first and second two-dimensional arrays 360, 370 of imaging lenses are placed in a 4-f telecentric arrangement with respect to the two-dimensional collimator-alignment mirror array 320 and the two-dimensional fiber collimator array 350. The channel micromirror 103 must be pivotable biaxially in this case (in order to direct its corresponding spectral channel to any one of the output ports). As such, the WSR apparatus 300 is equipped to support a greater number of the output ports.

In addition to facilitating the coupling of the spectral channels into the respective output ports as described above, the collimator-alignment mirrors in the above embodiments also serve to compensate for misalignment (e.g., due to fabricated and assembly errors) in the fiber collimators that provide for the input and output ports. For instance, relative misalignment between the fiber cores and their respective collimating lenses in the fiber collimators can lead to pointing errors in the collimated beams, which may be corrected for by the collimator-alignment mirrors. For these reasons, the collimator-alignment mirrors are preferably rotatable about two axes. They may be silicon micromachined mirrors, for fast rotational speeds. They may also be other types of mirrors or beam-deflecting elements known in the art.

To optimize the coupling of the spectral channels into the output ports and further maintain the optimal optical alignment against environment effects such as temperature variations and mechanical instabilities over the course of operation, a WSR apparatus of the present invention may incorporate a servo-control assembly, for providing dynamic control of the coupling of the spectral channels into the respective output ports on a channel-by-channel basis. A WSR apparatus incorporating a servo-control assembly is termed a WSR-S apparatus, hereinafter in this specification.

FIG. 4A depicts a schematic illustration of a first embodiment of a WSR-S apparatus according to the present invention. The WSR-S apparatus 400 comprises a WSR apparatus 410 and a servo-control assembly 440. The WSR 410 may be in the embodiment of FIG. 1A, or any other embodiment in accordance with the present invention. The servo-control assembly 440 includes a spectral monitor 460, for monitoring the power levels of the spectral channels coupled into the output ports 420-1 through 420-N of the WSR apparatus 410. By way of example, the spectral monitor 460 is coupled to the output ports 420-1 through 420-N by way of fiber-optic couplers 420-1 through 420-N-C, wherein each fiber-optic coupler serves to tap off a predetermined fraction of the optical signal in the corresponding output port. The servo-control assembly 440 further includes a processing unit 470, in communication with the spectral monitor 460 and the channel micromirrors 430 of the WSR apparatus 410. The processing unit 470 uses the power measurements from the spectral monitor 460 to provide feedback control of the channel micromirrors 430 on an individual basis, so as to maintain a desired coupling efficiency for each spectral channel into a selected output port. As such, the servo-control assembly 440 provides dynamic control of the coupling of the spectral channels into the respective output ports on a channel-by-channel basis and thereby manages the power levels of the spectral channels coupled into the output ports. The power levels of the spectral channels in the output ports may be dynamically managed according to demand, or maintained at desired values (e.g., equalized at a predetermined value) in the present invention. Such a

spectral power-management capability is essential in WDM optical networking applications, as discussed above.

FIG. 4B depicts a schematic illustration of a second embodiment of a WSR-S apparatus according to the present invention. The WSR-S apparatus 450 comprises a WSR apparatus 480 and a servo-control assembly 490. In addition to the channel micromirrors 430 (and other elements identified by the same numerals as those used in FIG. 4A), the WSR apparatus 480 further includes a plurality of collimator-alignment mirrors 485, and may be configured according to the embodiments of FIGS. 2A, 2B, 3, or any other embodiment in accordance with the present invention. By way of example, the servo-control assembly 490 includes the spectral monitor 460 as described in the embodiment of FIG. 4A, and a processing unit 495. In this case, the processing unit 495 is in communication with the channel micromirrors 430 and the collimator-alignment mirrors 485 of the WSR apparatus 480, as well as the spectral monitor 460. The processing unit 495 uses the power measurements from the spectral monitor 460 to provide dynamic control of the channel micromirrors 430 along with the collimator-alignment mirrors 485, so to maintain the coupling efficiencies of the spectral channels into the output ports at desired values.

In the embodiment of FIG. 4A or 4B, the spectral monitor 460 may be one of spectral power monitoring devices known in the art that is capable of detecting the power levels of spectral components in a multi-wavelength optical signal. Such devices are typically in the form of a wavelength-separating means (e.g., a diffraction grating) that spatially separates a multi-wavelength optical signal by wavelength into constituent spectral components, and one or more optical sensors (e.g., an array of photodiodes) that are configured such to detect the power levels of these spectral components. The processing unit 470 in FIG. 4A (or the processing unit 495 in FIG. 4B) typically includes electrical circuits and signal processing programs for processing the power measurements received from the spectral monitor 460 and generating appropriate control signals to be applied to the channel micromirrors 430 (and the collimator-alignment mirrors 485 in the case of FIG. 4B), so to maintain the coupling efficiencies of the spectral channels into the output ports at desired values. The electronic circuitry and the associated signal processing algorithm/software for such processing unit in a servo-control system are known in the art. A skilled artisan will know how to implement a suitable spectral monitor along with an appropriate processing unit to provide a servo-control assembly in a WSR-S apparatus according to the present invention, for a given application.

The incorporation of a servo-control assembly provides additional advantages of effectively relaxing the requisite fabrication tolerances and the precision of optical alignment during initial assembly of a WSR apparatus of the present invention, and further enabling the system to correct for shift in the alignment over the course of operation. By maintaining an optimal optical alignment, the optical losses incurred by the spectral channels are also significantly reduced. As such, the WSR-S apparatus thus constructed is simpler and more adaptable in structure, more robust in performance, and lower in cost and optical loss. Accordingly, the WSR-S (or WSR) apparatus of the present invention may be used to construct a variety of operable devices and utilized in many applications.

For instance, by directing the spectral channels into the output ports in a one-channel-per-port fashion and coupling the output ports of a WSR-S (or WSR) apparatus to an array of optical sensors (e.g., photodiodes), or a single optical

sensor that is capable of scanning across the output ports, a dynamic and versatile spectral power monitor (or channel analyzer) is provided, which would be highly desired in WDM optical networking applications. Moreover, a novel class of optical add-drop multiplexers (OADMs) may be built upon the WSR-S (or WSR) apparatus of the present invention, as exemplified in the following embodiments.

FIG. 5 depicts an exemplary embodiment of an optical add-drop multiplexer (OADM) according to the present invention. By way of example, OADM 500 comprises a WSR-S (or WSR) apparatus 510 and an optical combiner 550. An input port 520 of the WSR-S apparatus 510 transmits a multi-wavelength optical signal. The constituent spectral channels are subsequently separated and routed into a plurality of output ports, including a pass-through port 530 and one or more drop ports 540-1 through 540-N ($N \geq 1$). The pass-through port 530 may receive any number of the spectral channels (i.e., the pass-through spectral channels). Each drop port may also receive any number of the spectral channels (i.e., the drop spectral channels). The pass-through port 530 is optically coupled to the optical combiner 550, which serves to combine the pass-through spectral channels with one or more add spectral channels provided by one or more add ports 560-1 through 560-M ($M \geq 1$). The combined optical signal is then routed into an existing port 570, providing an output multi-wavelength optical signal.

In the above embodiment, the optical combiner 550 may be a $K \times 1$ ($K \geq 2$) broadband fiber-optic coupler, wherein there are K input-ends and one output-end. The pass-through spectral channels and the add spectral channels are fed into the K input-ends (e.g., in a one-to-one correspondence) and the combined optical signal exits from the output-end of the $K \times 1$ fiber-optic coupler as the output multi-wavelength optical signal of the system. Such a multiple-input coupler also serves the purpose of multiplexing a multiplicity of add spectral channels to be coupled into the OADM 500. If the power levels of the spectral channels in the output multi-wavelength optical signal are desired to be actively managed, such as being equalized at a predetermined value, two spectral monitors may be utilized. As a way of example, the first spectral monitor may receive optical signals tapped off from the pass-through port 530 and the drop ports 540-1 through 540-N (e.g., by way of fiber-optic couplers as depicted in FIG. 4A or 4B). The second spectral monitor receives optical signals tapped off from the exiting port 570. A servo-control system may be constructed accordingly for monitoring and controlling the pass-through, drop and add spectral channels. As such, the embodiment of FIG. 5 provides a versatile optical add-drop multiplexer in a simple and low-cost assembly, while providing multiple physically separate drop/add ports in a dynamically reconfigurable fashion.

FIG. 6 depicts an alternative embodiment of an optical add-drop multiplexer (OADM) according to the present invention. By way of example, OADM 600 comprises a first WSR-S apparatus 610 optically coupled to a second WSR-S apparatus 650. Each WSR-S apparatus may be in the embodiment of FIG. 4A or 4B. (A WSR apparatus of the embodiment of FIG. 1A, 2A, 2B, or 3 may be alternatively implemented.) The first WSR-S apparatus 610 includes an input port 620, a pass-through port 630, and one or more drop ports 640-1 through 640-N ($N \geq 1$). The pass-through spectral channels from the pass-through port 630 are further coupled to the second WSR-S apparatus 650, along with one or more add spectral channels emerging from add ports 660-1 through 660-M ($M \geq 1$). In this exemplary case, the pass-through port 630 and the add ports 660-1 through

660-M constitute the input ports for the second WSR-S apparatus 650. By way of its constituent wavelength-separator (e.g., a diffraction grating) and channel micromirrors (not shown in FIG. 6), the second WSR-S apparatus 650 serves to multiplex the pass-through spectral channels and the add spectral channels, and route the multiplexed optical signal into an exiting port 770 to provide an output signal of the system.

In the embodiment of FIG. 6, one WSR-S apparatus (e.g., the first WSR-S apparatus 610) effectively performs dynamic drop function, whereas the other WSR-S apparatus (e.g., the second WSR-S apparatus 650) carries out dynamic add function. And there are essentially no fundamental restrictions on the wavelengths that can be added or dropped (other than those imposed by the overall communication system). Moreover, the underlying OADM architecture thus presented is intrinsically scalable and can be readily extended to any number of cascaded WSR-S (or WSR) systems, if so desired for performing intricate add and drop functions. Additionally, the OADM of FIG. 6 may be operated in reverse direction, by using the input ports as the output ports, the drop ports as the add ports, and vice versa.

Those skilled in the art will recognize that the aforementioned embodiments provide only two of many embodiments of a dynamically reconfigurable OADM according to the present invention. Those skilled in the art will also appreciate that various changes, substitutions, and alternations can be made herein without departing from the principles and the scope of the invention as defined in the appended claims. Accordingly, a skilled artisan can design an OADM in accordance with the principles of the present invention, to best suit a given application.

Although the present invention and its advantages have been described in detail, it should be understood that various changes, substitutions, and alternations can be made herein without departing from the principles and the scope of the invention. Accordingly, the scope of the present invention should be determined by the following claims and their legal equivalents.

What is claimed is:

- ~~1. A wavelength separating routing apparatus, comprising:

 - a) multiple fiber collimators, providing an input port for a multi-wavelength optical signal and a plurality of output ports;
 - b) a wavelength separator, for separating said multi-wavelength optical signal from said input port into multiple spectral channels;
 - c) a beam focuser, for focusing said spectral channels into corresponding spectral spots; and
 - d) a spatial array of channel micromirrors positioned such that each channel micromirror receives one of said spectral channels, said channel micromirrors being pivotal about two axes and being individually and continuously controllable to reflect [said] corresponding received spectral channels into any selected ones of said output ports and to control the power of said received spectral channels coupled into said output ports.~~
- ~~2. The wavelength separating routing apparatus of claim 1 further comprising a servo control assembly, in communication with said channel micromirrors and said output ports, for providing control of said channel micromirrors and thereby maintaining a predetermined coupling of each reflected spectral channel into one of said output ports.~~
- ~~3. The wavelength separating routing apparatus of claim 2 wherein said servo control assembly comprises a spectral~~

15

~~monitor for monitoring power levels of said spectral channels coupled into said output ports, and a processing unit responsive to said power levels for providing control of said channel micromirrors.~~

~~4. The wavelength-separating-routing apparatus of claim 3 wherein said servo control assembly maintains said power levels at a predetermined value.~~

[[5. The wavelength-separating-routing apparatus of claim 1 further comprising an array of collimator-alignment mirrors, in optical communication with said wavelength-separator and said fiber collimators, for adjusting an alignment of said multi-wavelength optical signal from said input port and directing said reflected spectral channels into said output ports.]]

[[6. The wavelength-separating-routing apparatus of claim 5 wherein each collimator-alignment mirror is rotatable about one axis.]]

[[7. The wavelength-separating-routing apparatus of claim 5 wherein each collimator-alignment mirror is rotatable about two axes.]]

[[8. The wavelength-separating-routing apparatus of claim 5 further comprising first and second arrays of imaging lenses, in a telecentric arrangement with said collimator-alignment mirrors and said fiber collimators.]]

~~9. The wavelength-separating-routing apparatus of claim 1 wherein each channel micromirror is continuously pivotable about one axis.~~

~~10. The wavelength-separating-routing apparatus of claim 1 wherein each channel micromirror is pivotable about two axes.~~

[[11. The wavelength-separating-routing apparatus of claim 10 wherein said fiber collimators are arranged in a two-dimensional array.]]

[[12. The wavelength-separating-routing apparatus of claim 1 wherein each channel micromirror is a silicon micromachined mirror.]]

~~13. The wavelength-separating-routing apparatus of claim 1 wherein said fiber collimators are arranged in a one-dimensional array.~~

[[14. The wavelength-separating-routing apparatus of claim 1 wherein said beam-focuser comprises a focusing lens having first and second focal points.]]

[[15. The wavelength-separating-routing apparatus of claim 14 wherein said wavelength-separator and said channel micromirrors are placed respectively at said first and second focal points of said focusing lens.]]

[[16. The wavelength-separating-routing apparatus of claim 1 wherein said beam-focuser comprises an assembly of lenses.]]

~~17. The wavelength-separating-routing apparatus of claim 1 wherein said wavelength separator comprises an element selected from the group consisting of ruled diffraction gratings, holographic diffraction gratings, echelle gratings, curved diffraction gratings, and dispersing gratings.~~

[[18. The wavelength-separating-routing apparatus of claim 1 further comprising a quarter-wave plate optically interposed between said wavelength-separator and said channel micromirrors.]]

~~19. The wavelength-separating-routing apparatus of claim 1 wherein each output port carries a single one of said spectral channels.~~

~~20. The wavelength-separating-routing apparatus of claim 19 further comprising one or more optical sensors, optically coupled to said output ports.~~

16

~~21. A servo-based optical apparatus comprising:~~

~~a) multiple fiber collimators, providing an input port for a multi-wavelength optical signal and a plurality of output ports;~~

~~b) a wavelength separator, for separating said multi-wavelength optical signal from said input port into multiple spectral channels;~~

~~c) a beam-focuser, for focusing said spectral channels into corresponding spectral spots; and~~

~~d) a spatial array of channel micromirrors positioned such that each channel micromirror receives one of said spectral channels, said channel micromirrors being individually controllable to reflect said spectral channels into selected ones of said output ports; and~~

~~e) a servo control assembly, in communication with said channel micromirrors and said output ports, for maintaining a predetermined coupling of each reflected spectral channel into one of said output ports.~~

~~22. The servo-based optical apparatus of claim 21 wherein said servo control assembly comprises a spectral monitor for monitoring power levels of said spectral channels coupled into said output ports, and a processing unit responsive to said power levels for providing control of said channel micromirrors.~~

~~23. The servo-based optical apparatus of claim 22 wherein said servo control assembly maintains said power levels at a predetermined value.~~

[[24. The servo-based optical apparatus of claim 21 further comprising an array of collimator-alignment mirrors, in optical communication with said wavelength-separator and said fiber collimators, for adjusting an alignment of said multi-wavelength optical signal from said input port and directing said reflected spectral channels into said output ports.]]

[[25. The servo-based optical apparatus of claim 24 further comprising first and second arrays of imaging lenses, in a telecentric arrangement with said collimator-alignment mirrors and said fiber collimators.]]

[[26. The servo-based optical apparatus of claim 24 wherein each collimator-alignment mirror is rotatable about at least one axis.]]

~~27. The servo-based optical apparatus of claim 21 wherein each channel micromirror is continuously pivotable about at least one axis.~~

[[28. The servo-based optical apparatus of claim 21 wherein each channel micromirror is a silicon micromachined mirror.]]

~~29. The servo-based optical apparatus of claim 21 wherein said wavelength separator comprises an element selected from the group consisting of ruled diffraction gratings, holographic diffraction gratings, echelle gratings, curved diffraction gratings, and dispersing prisms.~~

[[30. The servo-based optical apparatus of claim 21 wherein said beam-focuser comprises one or more lenses.]]

[[31. An optical apparatus comprising:

a) an array of fiber collimators, providing an input port for a multi-wavelength optical signal and a plurality of output ports;

b) a wavelength-separator, for separating said multi-wavelength optical signal from said input port into multiple spectral channels;

c) a beam-focuser, for focusing said spectral channels into corresponding spectral spots;

d) a spatial array of channel micromirrors positioned such that each channel micromirror receives one of said spectral channels, said channel micromirrors being

individually and continuously controllable to reflect said spectral channels into selected ones of said output ports; and

- e) a one-dimensional array of collimator-alignment mirrors, for adjusting an alignment of said multi-wavelength optical signal from said input port and directing said reflected spectral channels into said output ports.]]]

[[[32. The optical apparatus of claim 31 further comprising a servo-control assembly, in communication with said channel micromirrors, said collimator-alignment mirrors, and said output ports, for providing control of said channel micromirrors along with said collimator-alignment mirrors and thereby maintaining a predetermined coupling of each reflected spectral channel into one of said output ports.]]]

[[[33. The optical apparatus of claim 32 wherein said servo-control assembly comprises a spectral monitor for monitoring power levels of said spectral channels coupled into said output ports, and a processing unit responsive to said power levels for providing control of said channel micromirrors and said collimator-alignment mirrors.]]]

[[[34. The optical apparatus of claim 31 wherein each channel micromirror is continuously pivotable about at least one axis.]]]

[[[35. The optical apparatus of claim 31 wherein each collimator-alignment mirror is rotatable about at least one axis.]]]

[[[36. The optical apparatus of claim 31 further comprising first and second arrays of imaging lenses, in a telecentric arrangement with said collimator-alignment mirrors and said fiber collimators.]]]

[[[37. An optical apparatus comprising:

- a) an array of fiber collimators, providing an input port for a multi-wavelength optical signal and a plurality of output ports;
- b) a wavelength-separator, for separating said multi-wavelength optical signal from said input port into multiple spectral channels;
- c) a beam-focuser, for focusing said spectral channels into corresponding spectral spots;
- d) a spatial array of channel micromirrors positioned such that each channel micromirror receives one of said spectral channels, said channel micromirrors being individually and continuously controllable to reflect said spectral channels into selected ones of said output ports; and
- e) a two-dimensional array of collimator-alignment mirrors, for adjusting an alignment of said multi-wavelength optical signal from said input port and directing said reflected spectral channels into said output ports.]]]

[[[38. The optical apparatus of claim 37 further comprising a servo-control assembly, in communication with said channel micromirrors, and collimator-alignment mirrors, and said output ports, for providing control of said channel micromirrors along with said collimator-alignment mirrors and thereby maintaining a predetermined coupling of each reflected spectral channel into one of said output ports.]]]

[[[39. The optical apparatus of claim 38 wherein said servo-control assembly comprises a spectral monitor for monitoring power levels of said spectral channels coupled into said output ports, and a processing unit responsive to said power levels for providing control of said channel micromirrors and said collimator-alignment mirrors.]]]

[[[40. The optical apparatus of claim 37 wherein each collimator-alignment mirror is rotatable about at least one axis.]]]

[[[41. The optical apparatus of claim 37 wherein each channel micromirror is continuously pivotable about at least one axis.]]]

[[[42. The optical apparatus of claim 41 wherein each channel micromirrors is pivotable about two axes, and wherein said fiber collimators are arranged in a two-dimensional array.]]]

[[[43. The optical apparatus of claim 37 further comprising first and second arrays of imaging lenses, in a telecentric arrangement with said collimator-alignment mirrors and said fiber collimators.]]]

~~44. An optical system comprising a wavelength separating routing apparatus, wherein said wavelength separating routing apparatus includes:~~

- ~~a) an array of fiber collimators, providing an input port for a multi-wavelength optical signal and a plurality of output ports including a pass-through port and one or more drop ports;~~
- ~~b) a wavelength separator, for separating said multi-wavelength optical signal from said input port into multiple spectral channels;~~
- ~~e) a beam-focuser, for focusing said spectral channels into corresponding spectral spots; and~~
- ~~d) a spatial array of channel micromirrors positioned such that each channel micromirror receives one of said spectral channels, said channel micromirrors being pivotal about two axes and being individually and continuously [pivotable] controllable to reflect [said] corresponding received spectral channels into any selected ones of said output ports and to control the power of said received spectral channels coupled into said output ports, whereby said pass through port receives a subset of said spectral channels.~~

~~45. The optical system of claim 44 further comprising a servo-control assembly, in communication with said channel micromirrors and said output ports, for providing control of said channel micromirrors and thereby maintaining a predetermined coupling of each reflected spectral channel into one of said output ports.~~

~~46. The optical system of claim 45 wherein said servo-control assembly comprises a spectral monitor for monitoring power levels of said spectral channels coupled into said output ports, and a processing unit responsive to said power levels for providing control of said channel micromirrors.~~

[[[47. The optical system of claim 44 further comprising an array of collimator-alignment mirrors, in optical communication with said wavelength-separator and said fiber collimators, for adjusting an alignment of said multi-wavelength optical signal from said input port and directing said reflected spectral channels into said output ports.]]]

[[[48. The optical system of claim 47 further comprising first and second arrays of imaging lenses, in a telecentric arrangement with said collimator-alignment mirrors and said fiber collimators.]]]

[[[49. The optical system of claim 47 wherein each collimator-alignment mirror is rotatable about at least one axis.]]]

[[[50. The optical system of claim 44 wherein each channel micromirror is pivotable about at least one axis.]]]

[[[51. The optical system of claim 44 wherein each channel micromirror is a silicon micromachined mirror.]]]

[[[52. The optical system of claim 44 wherein said beam-focuser comprises a focusing lens having first and second focal points, and wherein said wavelength-separator

and said channel micromirrors are placed respectively at said first and second focal points.]]]

~~53. The optical system of claim 44 wherein said wavelength separator comprises an element selected from the group consisting of ruled diffraction gratings, holographic diffraction gratings, echelle gratings, curved diffraction gratings, and dispersing prisms.~~

[[[54. The optical system of claim 44 further comprising a quarter-wave plate optically interposed between said wavelength-separator and said channel micromirrors.]]]

[[[55. The optical system of claim 44 further comprising an auxiliary wavelength-separating-routing apparatus, including:

- a) multiple auxiliary fiber collimators, providing a plurality of auxiliary input ports and an exiting port;
- b) an auxiliary wavelength-separator;
- c) an auxiliary beam-focuser; and
- d) a spatial array of auxiliary channel micromirrors;

wherein said subset of said spectral channels in said pass-through port and one or more add spectral channels are directed into said auxiliary input ports, and multiplexed into an output optical signal directed into said exiting port by way of said auxiliary wavelength-separator, said auxiliary beam-focuser and said auxiliary channel micromirrors.]]]

[[[56. The optical system of claim 55 wherein said auxiliary channel micromirrors are individually pivotable.]]]

[[[57. The optical system of claim 55 wherein each auxiliary channel micromirror is pivotable continuously about at least one axis.]]]

[[[58. The optical system of claim 55 wherein each auxiliary channel micromirror is a silicon micromachined mirror.]]]

[[[59. The optical system of claim 55 wherein said auxiliary wavelength-separator comprises an element selected from the group consisting of ruled diffraction gratings, holographic diffraction gratings, echelle gratings, curved diffraction gratings, and dispersing prisms.]]]

[[[60. The optical system of claim 55 wherein said pass-through port constitutes one of said auxiliary input ports.]]]

~~61. A method of performing dynamic wavelength separating and routing, comprising:~~

- a) ~~receiving a multi wavelength optical signal from an input port;~~
- b) ~~separating said multi wavelength optical signal into multiple spectral channels;~~
- c) ~~focusing said spectral channels onto a spatial array of corresponding beam deflecting elements, whereby each beam deflecting element receives one of said spectral channels; and~~
- d) ~~dynamically and continuously controlling said beam deflecting elements, thereby directing] in two dimensions to direct said spectral channels into [a plurality] any selected ones of said output ports and to control the power of the spectral channels coupled into said selected output ports.~~

~~62. The method of claim 61 further comprising the step of providing feedback control of said beam deflecting elements, thereby maintaining] to maintain a predetermined coupling of each spectral channel directed into one of said output ports.~~

~~63. The method of claim 62 further comprising the step of maintaining power levels of said spectral channels directed into said output ports at a predetermined value.~~

~~64. The method of claim 61 wherein each spectral channel is directed into a separate output port.~~

~~65. The method of claim 61 wherein a subset of said spectral channels is directed into one of said output ports, thereby providing one or more pass-through spectral channels.~~

[[[66. The method of claim 65 further comprising the step of multiplexing said pass-through spectral channels with one or more add spectral channels, so as to provide an output optical signal.]]]

[[[67. The method of claim 61 wherein said beam-deflecting elements comprise an array of silicon micromachined mirrors.]]]

68. A wavelength-separating-routing apparatus, comprising:

- a) **multiple fiber collimators, providing and serving as an input port for a multi-wavelength optical signal and a plurality of output ports;**
- b) **a wavelength-separator, for separating said multi-wavelength optical signal from said fiber collimator input port into multiple spectral channels;**
- c) **a beam-focuser, for focusing said spectral channels into corresponding spectral spots; and**
- d) **a spatial array of channel micromirrors positioned such that each channel micromirror receives one of said spectral channels, said channel micromirrors being pivotal about two axes and being individually and continuously controllable to reflect corresponding received spectral channels into any selected ones of said fiber collimator output ports and to control the power of said received spectral channels coupled into said fiber collimator output ports.**

69. The wavelength-separating-routing apparatus of claim 68 further comprising a servo-control assembly, in communication with said channel micromirrors and said fiber collimator output ports, for providing control of said channel micromirrors and thereby maintaining a predetermined coupling of each reflected spectral channel into one of said fiber collimator output ports.

70. The wavelength-separating-routing apparatus of claim 69 wherein said servo-control assembly comprises a spectral monitor for monitoring power levels of said spectral channels coupled into said fiber collimator output ports, and a processing unit responsive to said power levels for providing control of said channel micromirrors.

71. The wavelength-separating-routing apparatus of claim 70 wherein said servo-control assembly maintains said power levels at a predetermined value.

72. The wavelength-separating-routing apparatus of claim 68 further comprising an array of collimator-alignment mirrors, in optical communication with said wavelength-separator and said fiber collimator input and output ports, for adjusting an alignment of said multi-wavelength optical signal from said fiber collimator input port and directing said reflected spectral channels into said fiber collimator output ports.

73. The wavelength-separating-routing apparatus of claim 72 wherein each collimator-alignment mirror is rotatable about one axis.

74. The wavelength-separating-routing apparatus of claim 72 wherein each collimator-alignment mirror is rotatable about two axes.

75. The wavelength-separating-routing apparatus of claim 72 further comprising first and second arrays of imaging lenses, in a telecentric arrangement with said collimator-alignment mirrors and said fiber collimator input and output ports.

76. The wavelength-separating-routing apparatus of claim 68 wherein each channel micromirror is continuously pivotable about one axis.

77. The wavelength-separating-routing apparatus of claim 68 wherein each channel micromirror is pivotable about two axes.

78. The wavelength-separating-routing apparatus of claim 77 wherein said fiber collimator input and output ports are arranged in a two-dimensional array.

79. The wavelength-separating-routing apparatus of claim 68 wherein each channel micromirror is a silicon micromachined mirror.

80. The wavelength-separating-routing apparatus of claim 68 wherein said fiber collimator input and output ports are arranged in a one-dimensional array.

81. The wavelength-separating-routing apparatus of claim 68 wherein said beam-focuser comprises a focusing lens having first and second focal points.

82. The wavelength-separating-routing apparatus of claim 81 wherein said wavelength-separator and said channel micromirrors are placed respectively at said first and second focal points of said focusing lens.

83. The wavelength-separating-routing apparatus of claim 68 wherein said beam-focuser comprises an assembly of lenses.

84. The wavelength-separating-routing apparatus of claim 68 wherein said wavelength-separator comprises an element selected from the group consisting of ruled diffraction gratings, holographic diffraction gratings, echelle gratings, curved diffraction gratings, and dispersing gratings.

85. The wavelength-separating-routing apparatus of claim 68 further comprising a quarter-wave plate optically interposed between said wavelength-separator and said channel micromirrors.

86. The wavelength-separating-routing apparatus of claim 68 wherein each fiber collimator output port carries a single one of said spectral channels.

87. The wavelength-separating-routing apparatus of claim 86 further comprising one or more optical sensors, optically coupled to said fiber collimator output ports.

88. The wavelength-separating-routing apparatus of claim 68, wherein neither said multi-wavelength optical signal nor said spectral channels are transmitted through a circulator.

89. A servo-based optical apparatus comprising:

a) multiple fiber collimators, providing an input port for a multi-wavelength optical signal and a plurality of output ports;

b) a wavelength-separator, for separating said multi-wavelength optical signal from said fiber collimator input port into multiple spectral channels;

c) a beam-focuser, for focusing said spectral channels into corresponding spectral spots; and

d) a spatial array of channel micromirrors positioned such that each channel micromirror receives one of said spectral channels, said channel micromirrors being individually controllable to reflect said spectral channels into selected ones of said fiber collimator output ports; and

e) a servo-control assembly, in communication with said channel micromirrors and said fiber collimator output ports, for maintaining a predetermined coupling of each reflected spectral channel into one of said fiber collimator output ports.

90. The servo-based optical apparatus of claim 89 wherein said servo-control assembly comprises a spectral

monitor for monitoring power levels of said spectral channels coupled into said fiber collimator output ports, and a processing unit responsive to said power levels for providing control of said channel micromirrors.

91. The servo-based optical apparatus of claim 90 wherein said servo-control assembly maintains said power levels at a predetermined value.

92. The servo-based optical apparatus of claim 89 further comprising an array of collimator-alignment mirrors, in optical communication with said wavelength-separator and said fiber collimator input and output ports, for adjusting an alignment of said multi-wavelength optical signal from said fiber collimator input port and directing said reflected spectral channels into said fiber collimator output ports.

93. The servo-based optical apparatus of claim 92 further comprising first and second arrays of imaging lenses, in a telecentric arrangement with said collimator-alignment mirrors and said fiber collimator input and output ports.

94. The servo-based optical apparatus of claim 92 wherein each collimator-alignment mirror is rotatable about at least one axis.

95. The servo-based optical apparatus of claim 89 wherein each channel micromirror is continuously pivotable about at least one axis.

96. The servo-based optical apparatus of claim 89 wherein each channel micromirror is a silicon micromachined mirror.

97. The servo-based optical apparatus of claim 89 wherein said wavelength-separator comprises an element selected from the group consisting of ruled diffraction gratings, holographic diffraction gratings, echelle gratings, curved diffraction gratings, and dispersing prisms.

98. The servo-based optical apparatus of claim 89 wherein said beam-focuser comprises one or more lenses.

99. The servo-based optical apparatus of claim 89, wherein neither said multi-wavelength optical signal nor said spectral channels are transmitted through a circulator.

100. An optical apparatus comprising:

a) an array of fiber collimators providing and serving as an input port for a multi-wavelength optical signal;

b) a plurality of output ports;

c) a wavelength-separator, for separating said multi-wavelength optical signal from said fiber collimator input port into multiple spectral channels;

d) a beam-focuser, for focusing said spectral channels into corresponding spectral spots;

e) a spatial array of channel micromirrors positioned such that each channel micromirror receives one of said spectral channels, said channel micromirrors being individually and continuously controllable to reflect said spectral channels into selected ones of said output ports; and

f) a one-dimensional array of collimator-alignment mirrors, for adjusting an alignment of said multi-wavelength optical signal from said fiber collimator input port and directing said reflected spectral channels into said output ports.

101. The optical apparatus of claim 100 further comprising a servo-control assembly, in communication with said channel micromirrors, said collimator-alignment mirrors, and said output ports, for providing control of said channel micromirrors along with said collimator-align-

ment mirrors and thereby maintaining a predetermined coupling of each reflected spectral channel into one of said output ports.

102. The optical apparatus of claim 101 wherein said servo-control assembly comprises a spectral monitor for monitoring power levels of said spectral channels coupled into said output ports, and a processing unit responsive to said power levels for providing control of said channel micromirrors and said collimator-alignment mirrors.

103. The optical apparatus of claim 100 wherein each channel micromirror is continuously pivotable about at least one axis.

104. The optical apparatus of claim 100 wherein each collimator-alignment mirror is rotatable about at least one axis.

105. The optical apparatus of claim 100 further comprising first and second arrays of imaging lenses, in a telecentric arrangement with said collimator-alignment mirrors and said fiber collimators.

106. The optical apparatus of claim 100, wherein neither said multi-wavelength optical signal nor said spectral channels are transmitted through a circulator.

107. An optical apparatus comprising:

- a) an array of fiber collimators, providing and serving as an input port for a multi-wavelength optical signal;
- b) a plurality of output ports;
- c) a wavelength-separator, for separating said multi-wavelength optical signal from said fiber collimator input port into multiple spectral channels;
- d) a beam-focuser, for focusing said spectral channels into corresponding spectral spots;
- e) a spatial array of channel micromirrors positioned such that each channel micromirror receives one of said spectral channels, said channel micromirrors being individually and continuously controllable to reflect said spectral channels into selected ones of said output ports; and
- f) a two-dimensional array of collimator-alignment mirrors, for adjusting an alignment of said multi-wavelength optical signal from said fiber collimator input port and directing said reflected spectral channels into said output ports.

108. The optical apparatus of claim 107 further comprising a servo-control assembly, in communication with said channel micromirrors, and collimator-alignment mirrors, and said output ports, for providing control of said channel micromirrors along with said collimator-alignment mirrors and thereby maintaining a predetermined coupling of each reflected spectral channel into one of said output ports.

109. The optical apparatus of claim 108 wherein said servo-control assembly comprises a spectral monitor for monitoring power levels of said spectral channels coupled into said output ports, and a processing unit responsive to said power levels for providing control of said channel micromirrors and said collimator-alignment mirrors.

110. The optical apparatus of claim 107 wherein each collimator-alignment mirror is rotatable about at least one axis.

111. The optical apparatus of claim 107 wherein each channel micromirror is continuously pivotable about at least one axis.

112. The optical apparatus of claim 111 wherein each channel micromirror is pivotable about two axes, and wherein said fiber collimators are arranged in a two-dimensional array.

113. The optical apparatus of claim 107 further comprising first and second arrays of imaging lenses, in a telecentric arrangement with said collimator-alignment mirrors and said fiber collimators.

114. The optical apparatus of claim 107, wherein neither said multi-wavelength optical signal nor said spectral channels are transmitted through a circulator.

115. An optical system comprising a wavelength-separating-routing apparatus, wherein said wavelength-separating-routing apparatus includes:

- a) an array of fiber collimators, providing and serving as an input port for a multi-wavelength optical signal;
- b) a plurality of output ports including a pass-through port and one or more drop ports;
- c) a wavelength-separator, for separating said multi-wavelength optical signal from said fiber collimator input port into multiple spectral channels;
- d) a beam-focuser, for focusing said spectral channels into corresponding spectral spots; and
- e) a spatial array of channel micromirrors positioned such that each channel micromirror receives one of said spectral channels, said channel micromirrors being pivotal about two axes and being individually and continuously controllable to reflect corresponding received spectral channels into any selected ones of said output ports and to control the power of said received spectral channels coupled into said output ports, whereby said fiber collimator pass-through port receives a subset of said spectral channels.

116. The optical system of claim 115 further comprising a servo-control assembly, in communication with said channel micromirrors and said output ports, for providing control of said channel micromirrors and thereby maintaining a predetermined coupling of each reflected spectral channel into one of said output ports.

117. The optical system of claim 116 wherein said servo-control assembly comprises a spectral monitor for monitoring power levels of said spectral channels coupled into said output ports, and a processing unit responsive to said power levels for providing control of said channel micromirrors.

118. The optical system of claim 115 further comprising an array of collimator-alignment mirrors, in optical communication with said wavelength-separator and said fiber collimators, for adjusting an alignment of said multi-wavelength optical signal from said fiber collimator input port and directing said reflected spectral channels into said output ports.

119. The optical system of claim 118 further comprising first and second arrays of imaging lenses, in a telecentric arrangement with said collimator-alignment mirrors and said fiber collimators.

120. The optical system of claim 118 wherein each collimator-alignment mirror is rotatable about at least one axis.

121. The optical system of claim 115 wherein each channel micromirror is pivotable about at least one axis.

122. The optical system of claim 115 wherein each channel micromirror is a silicon micromachined mirror.

123. The optical system of claim 115 wherein said beam-focuser comprises a focusing lens having first and second focal points, and wherein said wavelength-separator and said channel micromirrors are placed respectively at said first and second focal points.

124. The optical system of claim 115 wherein said wavelength-separator comprises an element selected from the group consisting of ruled diffraction gratings, holo-

25

graphic diffraction gratings, echelle gratings, curved diffraction gratings, and dispersing prisms.

125. *The optical system of claim 115 further comprising a quarter-wave plate optically interposed between said wavelength-separator and said channel micromirrors.*

126. *The optical system of claim 115 further comprising an auxiliary wavelength-separating-routing apparatus, including:*

- a) *multiple auxiliary fiber collimators, providing and serving as a plurality of auxiliary input ports;*
- b) *an exiting port;*
- c) *an auxiliary wavelength-separator;*
- d) *an auxiliary beam-focuser; and*
- e) *a spatial array of auxiliary channel micromirrors;*

wherein

said subset of said spectral channels in said fiber collimator pass-through port and one or more add spectral channels are directed into said fiber collimator auxiliary input ports, and multiplexed into an output optical signal directed into said exiting port by way of said auxiliary wavelength-separator, said auxiliary beam-focuser and said auxiliary channel micromirrors.

127. *The optical system of claim 126 wherein said auxiliary channel micromirrors are individually pivotable.*

128. *The optical system of claim 126 wherein each auxiliary channel micromirror is pivotable continuously about at least one axis.*

129. *The optical system of claim 126 wherein each auxiliary channel micromirror is a silicon micromachined mirror.*

130. *The optical system of claim 126 wherein said auxiliary wavelength-separator comprises an element selected from the group consisting of ruled diffraction gratings, holographic diffraction gratings, echelle gratings, curved diffraction gratings, and dispersing prisms.*

131. *The optical system of claim 126 wherein said fiber collimator pass-through port constitutes one of said fiber collimator auxiliary input ports.*

26

132. *The optical system of claim 115, wherein neither said multi-wavelength optical signal nor said spectral channels are transmitted through a circulator.*

133. *A method of performing dynamic wavelength separating and routing, comprising:*

- a) *receiving a multi-wavelength optical signal from a fiber collimator input port;*
- b) *separating said multi-wavelength optical signal into multiple spectral channels;*
- c) *focusing said spectral channels onto a spatial array of corresponding beam-deflecting elements, whereby each beam-deflecting element receives one of said spectral channels; and*
- d) *dynamically and continuously controlling said beam-deflecting elements in two dimensions to direct said spectral channels into any selected ones of output ports and to control the power of the spectral channels coupled into said selected output ports.*

134. *The method of claim 133 further comprising the step of providing feedback control of said beam-deflecting elements to maintain a predetermining coupling of each spectral channel directed into one of said output ports.*

135. *The method of claim 134 further comprising the step of maintaining power levels of said spectral channels directed into said output ports at a predetermining value.*

136. *The method of claim 133 wherein each spectral channel is directed into a separate output port.*

137. *The method of claim 133 wherein a subset of said spectral channels is directed into one of said output ports, thereby providing one or more pass-through spectral channels.*

138. *The method of claim 137 further comprising the step of multiplexing said pass-through spectral channels with one or more add spectral channels, so as to provide an output optical signal.*

139. *The method of claim 133 wherein said beam-deflecting elements comprise an array of silicon micromachined mirrors.*

* * * * *