



US00RE47789E

(19) **United States**
(12) **Reissued Patent**
Ball et al.

(10) **Patent Number:** **US RE47,789 E**
(45) **Date of Reissued Patent:** ***Dec. 31, 2019**

(54) **SANITARY HYDRANT**

(71) Applicant: **WCM Industries, Inc.**, Colorado Springs, CO (US)

(72) Inventors: **William T. Ball**, Colorado Springs, CO (US); **Eric Pilarczyk**, Colorado Springs, CO (US); **Cody Jackson**, Colorado Springs, CO (US)

(73) Assignee: **WCM Industries, Inc.**, Colorado Springs, CO (US)

(*) Notice: This patent is subject to a terminal disclaimer.

(21) Appl. No.: **15/958,901**

(22) Filed: **Apr. 20, 2018**

Related U.S. Patent Documents

Reissue of:

(64) Patent No.: **9,593,471**
Issued: **Mar. 14, 2017**
Appl. No.: **14/988,600**
Filed: **Jan. 5, 2016**

U.S. Applications:

(63) Continuation of application No. 14/623,730, filed on Feb. 17, 2015, now Pat. No. 9,228,327, which is a continuation of application No. 13/933,264, filed on Jul. 2, 2013, now Pat. No. 8,955,538, which is a continuation of application No. 13/048,445, filed on Mar. 15, 2011, now Pat. No. 8,474,476.

(60) Provisional application No. 61/313,918, filed on Mar. 15, 2010, provisional application No. 61/313,902, filed on Mar. 15, 2010.

(51) **Int. Cl.**
E03B 9/14 (2006.01)
E03B 9/02 (2006.01)

(52) **U.S. Cl.**

CPC **E03B 9/14** (2013.01); **E03B 9/027** (2013.01); **Y10T 137/0318** (2015.04); **Y10T 137/5327** (2015.04); **Y10T 137/5444** (2015.04); **Y10T 137/5497** (2015.04); **Y10T 137/87338** (2015.04)

(58) **Field of Classification Search**

CPC **E03B 9/14**; **E03B 9/027**; **Y10T 137/0318**; **Y10T 137/5327**; **Y10T 137/87338**; **Y10T 137/5497**; **Y10T 137/5444**

See application file for complete search history.

(56) **References Cited**

U.S. PATENT DOCUMENTS

21,858 A	10/1858	Swan
53,944 A	4/1866	Biggs et al.
244,804 A	7/1881	Gillespie
556,500 A	3/1896	Fox
609,805 A	8/1898	Hardy
610,470 A	9/1898	Buehler
616,542 A	12/1898	Koehne
695,147 A	3/1902	Denney
695,311 A	3/1902	Hickey

(Continued)

OTHER PUBLICATIONS

U.S. Appl. No. 15/416,175, Notice of Allowance dated Jul. 13, 2018, 8 pages. (WMC-43-CON-4).

(Continued)

Primary Examiner — William C Doerrler

(57) **ABSTRACT**

A freeze resistant sanitary hydrant is provided that employs a reservoir for storage of fluid under the frost line or in an area not prone to freezing. To evacuate this reservoir, a means for altering pressure is provided that is able to function in hydrant systems that employ a vacuum breaker.

10 Claims, 19 Drawing Sheets

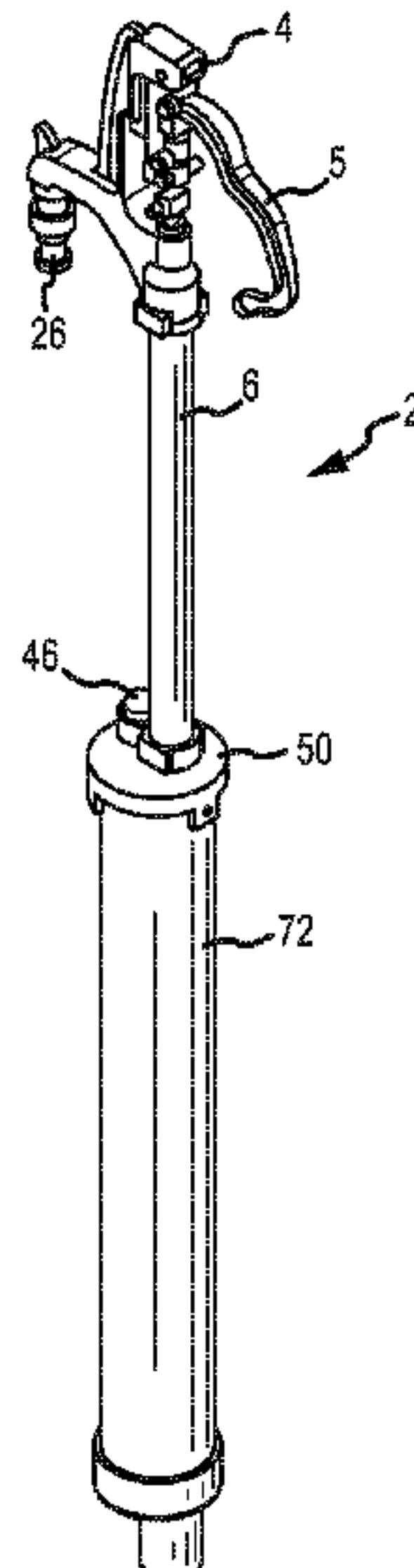

(56)

References Cited

U.S. PATENT DOCUMENTS

926,185 A	9/1909	Hayes	3,818,874 A	6/1974	Tria
934,188 A	9/1909	Kirby	3,885,585 A	5/1975	Carpentier
962,294 A	6/1910	Armington	D236,892 S	9/1975	Carlson
1,021,537 A	3/1912	Lawnin	3,905,382 A	9/1975	Waterston
1,069,003 A	7/1913	Haennig	3,913,602 A	10/1975	Yoon
1,310,521 A	7/1919	Crall	3,926,206 A	12/1975	Anderson et al.
1,426,407 A	8/1922	Pennington	3,926,207 A	12/1975	Anderson et al.
1,433,110 A	10/1922	Buckler	3,952,770 A	4/1976	Botnick
1,556,241 A	10/1925	Mueller	3,983,896 A	10/1976	Harrington
1,570,180 A	1/1926	Pulliam	4,008,732 A	2/1977	Fichter et al.
1,621,905 A	3/1927	Russell	4,013,088 A	3/1977	Gocke et al.
1,774,307 A	8/1930	Willig	D244,605 S	6/1977	Ratnik
1,828,763 A	10/1931	Carnes	4,034,174 A	7/1977	McCord
1,936,669 A	11/1933	Heeter	4,093,280 A	6/1978	Yoshizawa et al.
1,937,667 A	12/1933	Parsley et al.	4,096,877 A	6/1978	Arledge, II
2,025,067 A	12/1935	Miller	4,103,941 A	8/1978	Stoll
2,072,427 A	3/1937	O'Brien	4,109,671 A	8/1978	Hughes et al.
2,077,021 A	4/1937	Sites	4,112,966 A	9/1978	Carlson
2,097,733 A	11/1937	Miller	4,117,856 A	10/1978	Carlson
2,140,829 A	12/1938	Child	4,134,424 A	1/1979	Zeyra et al.
2,306,012 A	12/1942	Campbell	4,158,366 A	6/1979	Van Meter
2,329,960 A	9/1943	Verheul	4,178,956 A	12/1979	Fillman
2,429,940 A	10/1947	McDaniel	4,182,356 A	1/1980	Woodford, Sr.
2,484,063 A	10/1949	Ackley	4,209,033 A	6/1980	Hirsch et al.
2,498,395 A	2/1950	Coss	4,212,319 A	7/1980	Krablin
2,574,625 A	11/1951	Coss	4,266,813 A	5/1981	Oliver
2,580,199 A	12/1951	Schmid	4,281,857 A	8/1981	Randall
2,583,956 A	1/1952	Lindsay et al.	4,282,895 A	8/1981	Young
2,598,488 A	5/1952	Bart	4,286,616 A	9/1981	Botnick
2,598,968 A *	6/1952	Boosey E03B 9/14 137/282	4,300,593 A	11/1981	Ritter
2,599,325 A	6/1952	Fritzberg	4,316,481 A	2/1982	Fillman
2,605,781 A	8/1952	Schmid et al.	4,429,422 A	2/1984	Wareham
2,629,402 A	2/1953	Cook	D275,512 S	9/1984	Shaw
2,652,224 A	9/1953	Noland	4,475,570 A	10/1984	Pike et al.
2,664,096 A	12/1953	Murdock et al.	4,483,361 A	11/1984	Jungbert, Sr.
2,675,825 A	4/1954	Hobbs et al.	4,503,877 A	3/1985	Ward et al.
2,688,976 A	9/1954	Baker	4,577,653 A	3/1986	Marty
2,708,449 A	5/1955	Keithley	D284,302 S	6/1986	Hammarstedt
2,730,326 A	1/1956	Staben	4,609,006 A	9/1986	Parkison et al.
2,893,418 A	7/1959	Leventhal	4,619,287 A	10/1986	Hama et al.
2,949,933 A	8/1960	Moen	4,649,959 A	3/1987	Wadleigh
2,986,341 A	5/1961	Goodrie	4,653,521 A	3/1987	Fillman et al.
2,997,054 A	8/1961	Woodford	4,653,522 A	3/1987	Fillman et al.
3,014,667 A	12/1961	McLean et al.	4,655,486 A	4/1987	Tarnay et al.
3,017,896 A	1/1962	Papacek	4,700,732 A	10/1987	Francisco
3,023,767 A	3/1962	Woodford	4,703,956 A	11/1987	Keech
3,029,603 A	4/1962	Ackroyd	4,712,575 A	12/1987	Lair
3,056,418 A	10/1962	Adams et al.	4,712,812 A	12/1987	Weir, III
3,070,116 A	12/1962	Noland et al.	D297,971 S	10/1988	Kiyota et al.
3,146,142 A	8/1964	Maly	4,776,362 A	10/1988	Domingue et al.
3,150,383 A	9/1964	Reich	4,784,303 A	11/1988	Ahad et al.
3,155,107 A	11/1964	Woodford	4,790,573 A	12/1988	Cardozo
3,162,407 A	12/1964	Yax	4,798,221 A	1/1989	Crawford et al.
3,244,192 A	4/1966	Noland	4,821,762 A	4/1989	Breneman
3,283,093 A	11/1966	Bishop	4,821,763 A	4/1989	Ackroyd et al.
3,348,862 A	10/1967	Leopold, Jr. et al.	4,854,339 A	8/1989	Hoepfner, III
3,380,464 A	4/1968	Arterbury	4,884,725 A	12/1989	Ahad et al.
3,384,113 A	5/1968	Pennisi	4,909,270 A	3/1990	Enterante, Sr. et al.
3,390,898 A	7/1968	Sumida	4,937,559 A	6/1990	Meacham et al.
3,392,745 A	7/1968	Noland	4,946,434 A	8/1990	Plaisted et al.
3,407,837 A	10/1968	Fulton et al.	4,964,657 A	10/1990	Gonzales
3,414,001 A	12/1968	Woodford	4,976,279 A	12/1990	King, Sr. et al.
3,416,555 A	12/1968	Chapou	4,984,306 A	1/1991	Sumerix
3,424,189 A	1/1969	Woodford	5,024,419 A	6/1991	Mulvey
3,429,596 A	2/1969	Marshall	5,029,603 A	7/1991	Ackroyd
3,480,027 A	11/1969	Noland	5,033,500 A	7/1991	Hoepfner, III
3,543,786 A	12/1970	Woodford	5,045,836 A	9/1991	Nobles, Jr.
3,566,905 A	3/1971	Noland	5,050,632 A	9/1991	Means, Jr.
3,612,584 A	10/1971	Taylor	5,054,517 A	10/1991	Liesenhoff et al.
3,638,680 A	2/1972	Kopp	5,058,627 A	10/1991	Brannen
3,679,241 A	7/1972	Hoffmann	5,109,929 A	5/1992	Spears
D227,365 S	6/1973	Woodford	5,129,416 A	7/1992	Ackroyd
D227,366 S	6/1973	Woodford	5,135,028 A	8/1992	Rickenbach et al.
3,770,003 A	11/1973	Uroshevich	5,160,179 A	11/1992	Takagi
			5,195,785 A	3/1993	Jellison
			5,205,325 A	4/1993	Piper
			5,217,040 A	6/1993	Hochstrasser
			5,226,629 A	7/1993	Millman et al.
			5,228,470 A	7/1993	Lair et al.

(56)

References Cited

U.S. PATENT DOCUMENTS

5,241,981 A 9/1993 Ahern
 5,246,028 A 9/1993 Vandepas
 5,261,441 A 11/1993 Anderson
 5,284,582 A 2/1994 Yang
 5,366,257 A 11/1994 McPherson et al.
 5,392,805 A 2/1995 Chrysler
 5,394,572 A 3/1995 Humphreys
 5,399,173 A 3/1995 Parks et al.
 5,402,815 A 4/1995 Hoch, Jr. et al.
 5,437,481 A 8/1995 Spears et al.
 5,482,329 A 1/1996 McCall et al.
 5,496,076 A 3/1996 Lin
 5,551,473 A 9/1996 Lin et al.
 5,555,907 A 9/1996 Philipp
 5,590,679 A 1/1997 Almasy et al.
 5,603,347 A 2/1997 Eaton
 5,632,303 A 5/1997 Almasy et al.
 5,649,723 A 7/1997 Larsson
 5,653,254 A 8/1997 Condon et al.
 5,690,141 A 11/1997 Creaghe
 5,701,925 A 12/1997 Mulligan et al.
 5,740,831 A 4/1998 DeNardo et al.
 5,752,542 A 5/1998 Hoeptner, III
 5,788,443 A 8/1998 Cabahug
 5,813,428 A 9/1998 Almasy et al.
 5,890,241 A 4/1999 Ball
 5,906,341 A 5/1999 Brown
 5,911,240 A 6/1999 Kolar et al.
 5,961,095 A 10/1999 Schroff
 5,964,246 A 10/1999 Meeker
 D421,092 S 2/2000 Martin
 6,041,611 A 3/2000 Palmer
 6,047,723 A 4/2000 Hoeptner, III
 6,132,138 A 10/2000 Haese
 6,135,359 A 10/2000 Almasy et al.
 6,142,172 A 11/2000 Shuler et al.
 6,178,988 B1 1/2001 Royle
 6,186,558 B1 2/2001 Komolrochanaporn
 D439,311 S 3/2001 Martin
 6,206,039 B1 3/2001 Shuler et al.
 6,247,491 B1 6/2001 Petryna
 6,338,364 B1 1/2002 Mendenhall
 6,363,960 B1 4/2002 Gauss
 6,427,716 B1 8/2002 Hoeptner, III
 6,431,204 B1 8/2002 Ball
 6,447,017 B1 9/2002 Gilbreath et al.
 6,464,266 B1 10/2002 O'Neill et al.
 6,467,752 B2 10/2002 Woods
 D470,915 S 2/2003 Ball
 6,513,543 B1 2/2003 Noll et al.
 6,517,124 B1 2/2003 Le Quere
 6,526,701 B2 3/2003 Stearns et al.
 6,532,986 B1 3/2003 Dickey et al.
 D473,631 S 4/2003 Lai
 6,550,495 B1 4/2003 Schulze
 6,631,623 B1 10/2003 Ball
 D482,431 S 11/2003 Ball
 6,678,903 B1 1/2004 Rhodes
 6,679,473 B1 1/2004 Ball
 6,769,446 B1 8/2004 Ball et al.
 6,805,154 B1 10/2004 Dickey et al.
 6,816,072 B2 11/2004 Zoratti
 6,830,063 B1 12/2004 Ball
 6,857,442 B1 2/2005 Ball et al.
 6,860,523 B2 3/2005 O'Neill et al.
 6,880,573 B2 4/2005 Berkman et al.
 6,883,534 B2 4/2005 Ball et al.
 6,899,120 B1 5/2005 Motley
 6,948,509 B1 9/2005 Ball et al.
 6,948,518 B1 9/2005 Ball
 7,013,910 B2 3/2006 Tripp
 D521,113 S 5/2006 Ball
 7,059,937 B2 6/2006 Brown
 RE39,235 E 8/2006 Shuler et al.
 7,100,637 B1 9/2006 Ball

7,111,875 B2 9/2006 Ball
 7,143,779 B2 12/2006 Parker
 7,234,479 B2 6/2007 Murdock
 7,234,732 B2 6/2007 Ball
 7,258,128 B2 8/2007 Gomo et al.
 7,314,057 B2 1/2008 Parker
 D574,065 S 7/2008 Ball
 7,434,593 B2 10/2008 Noll et al.
 7,472,718 B2 1/2009 Ball
 7,730,901 B2 6/2010 Ball
 8,042,565 B2 10/2011 Ball et al.
 8,408,238 B1 4/2013 Anderson
 8,474,476 B2 7/2013 Ball et al. E03B 9/14
 137/301
 8,955,538 B2 2/2015 Ball et al. E03B 9/14
 137/301
 9,228,327 B2 1/2016 Ball et al. E03B 9/14
 9,593,471 B2 * 3/2017 Ball E03B 9/14
 9,890,867 B2 2/2018 Ball et al.
 2001/0003350 A1 6/2001 Gandy et al.
 2002/0189674 A1 12/2002 Meeder
 2005/0173001 A1 8/2005 Murdock
 2006/0117734 A1 6/2006 Larkin et al.
 2006/0254647 A1 11/2006 Ball
 2007/0039649 A1 2/2007 Ball
 2007/0044838 A1 3/2007 Ball
 2007/0044840 A1 3/2007 Ball et al.
 2007/0163653 A1 7/2007 Gomo et al.
 2007/0240765 A1 10/2007 Katzman et al.
 2008/0047612 A1 2/2008 Ball
 2009/0288722 A1 * 11/2009 Ball E03C 1/106
 137/614.2
 2017/0218602 A1 8/2017 Ball et al.

OTHER PUBLICATIONS

U.S. Appl. No. 15/416,175, Notice of Allowance dated Nov. 21, 2018, 8 pages. (WMC-43-CON-4).
 Canadian Official Action for Canada Patent Application No. 2,734,529, dated Jul. 20, 2012 2 pages.
 Final Action for U.S. Appl. No. 13/933,264 dated Jul. 25, 2014, 10 pages.
 Notice of Allowance for U.S. Appl. No. 12/126,476, dated Aug. 18, 2011.
 Notice of Allowance for U.S. Appl. No. 13/048,445 dated Mar. 6, 2013, 8 pages.
 Notice of Allowance for U.S. Appl. No. 13/933,264 dated Oct. 16, 2014, 5 pages.
 Notice of Allowance for U.S. Appl. No. 14/623,730, dated Sep. 22, 2015, 5 pages.
 Official Action for US. Appl. No. 12/126,476, dated Feb. 9, 2011.
 Official Action for U.S. Appl. No. 12/126,476, dated Jun. 14, 2011.
 Official Action for U.S. Appl. No. 13/933,264 dated Apr. 11, 2014, 17 pages.
 Official Action for U.S. Appl. No. 14/623,730 dated Aug. 25, 2015 9 pages.
 Official Action for U.S. Appl. No. 14/988,600 dated Sep. 21, 2016 9 pages.
 U.S. Appl. No. 14/988,600, Notice of Allowance dated Jan. 5, 2017, 7 pages. (WMC-43-CON-3).
 U.S. Appl. No. 15/416,175, Office Action dated Oct. 2, 2017, 8 pages (WMC-43-CON-4).
 U.S. Appl. No. 15/416,175, Notice of Allowance dated Jan. 25, 2018, 7 pages. (WMC-43-CON-4).
 U.S. Appl. No. 15/416,175, Office Action dated Aug. 28, 2019, 6 pages.
 MPH-24 Pedestal Hydrant, MAPA Products, May 2002, 2 pages.
 MPH-24D Pedestal Hydrant, MAPA Products, Apr. 2007, 1 page.
 MPH-24FP Pedestal Hydrant, MAPA Products, Jan. 2004, 1 page.
 MPH-24 Pedestal Hydrant, MAPA Products, Jan. 2004, 1 page.
 "VB-222 Self-Draining Hose Connection Vacuum Breaker," A.W. Cash Value Company Model VB-222, Mar. 12, 2008, pp. 1-2.
 Notice of Allowance for U.S. Appl. No. 13/048,445 mailed Mar. 6, 2013, 8 pages.

(56)

References Cited

OTHER PUBLICATIONS

Official Action for U.S. Appl. No. 13/933,264 mailed Apr. 11, 2014, 17 pages.

Final Action for U.S. Appl. No. 13/933,264 mailed Jul. 25, 2014, 10 pages.

Notice of Allowance for U.S. Appl. No. 13/933,264 mailed Oct. 16, 2014, 5 pages.

Official Action for U.S. Appl. No. 14/623,730 mailed Aug. 25, 2015 9 pages.

Notice of Allowance for U.S. Appl. No. 14/623,730, mailed Sep. 22, 2015, 5 pages.

U.S. Appl. No. 15/238,914, filed Aug. 17, 2016, Ball et al.

* cited by examiner

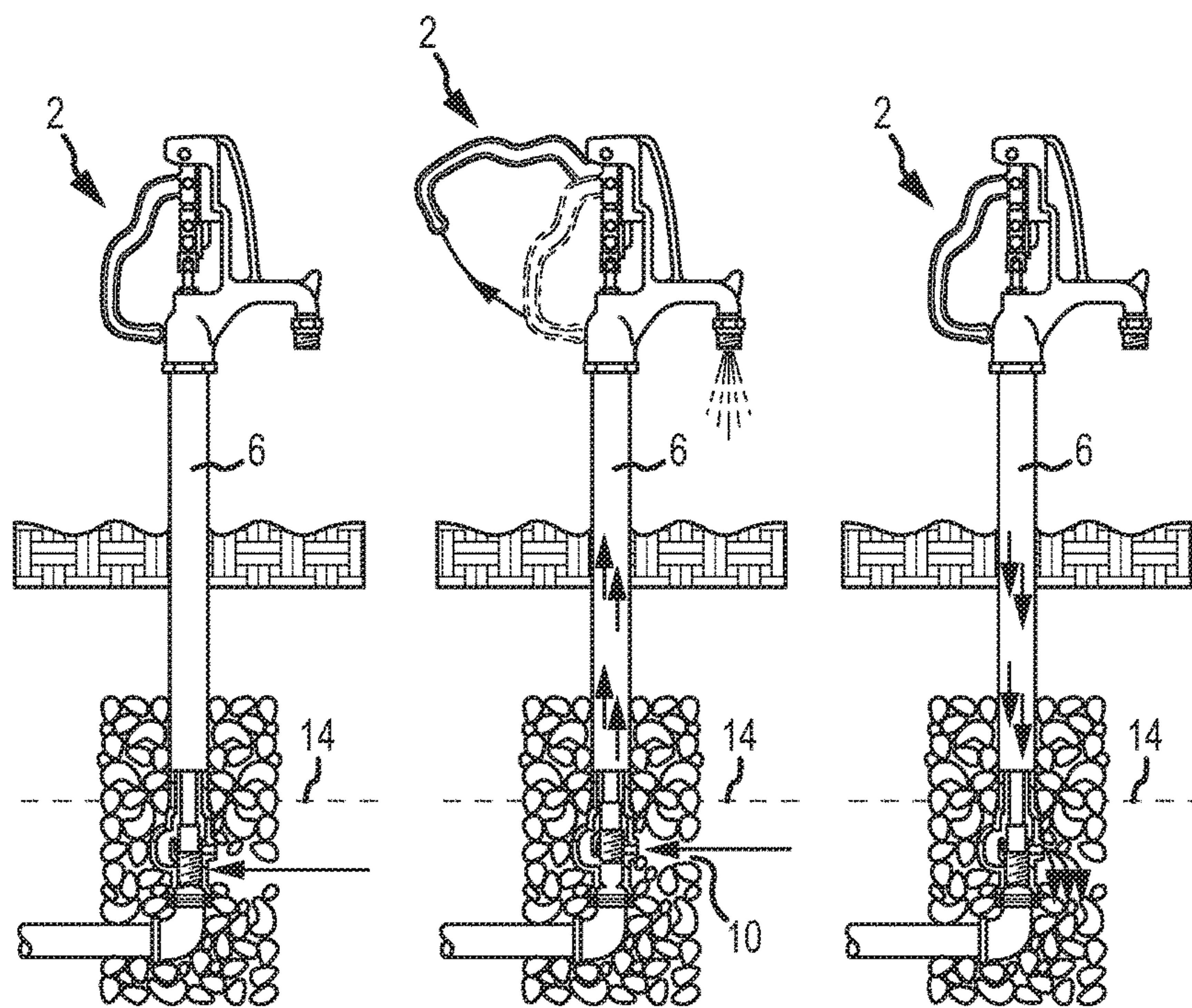
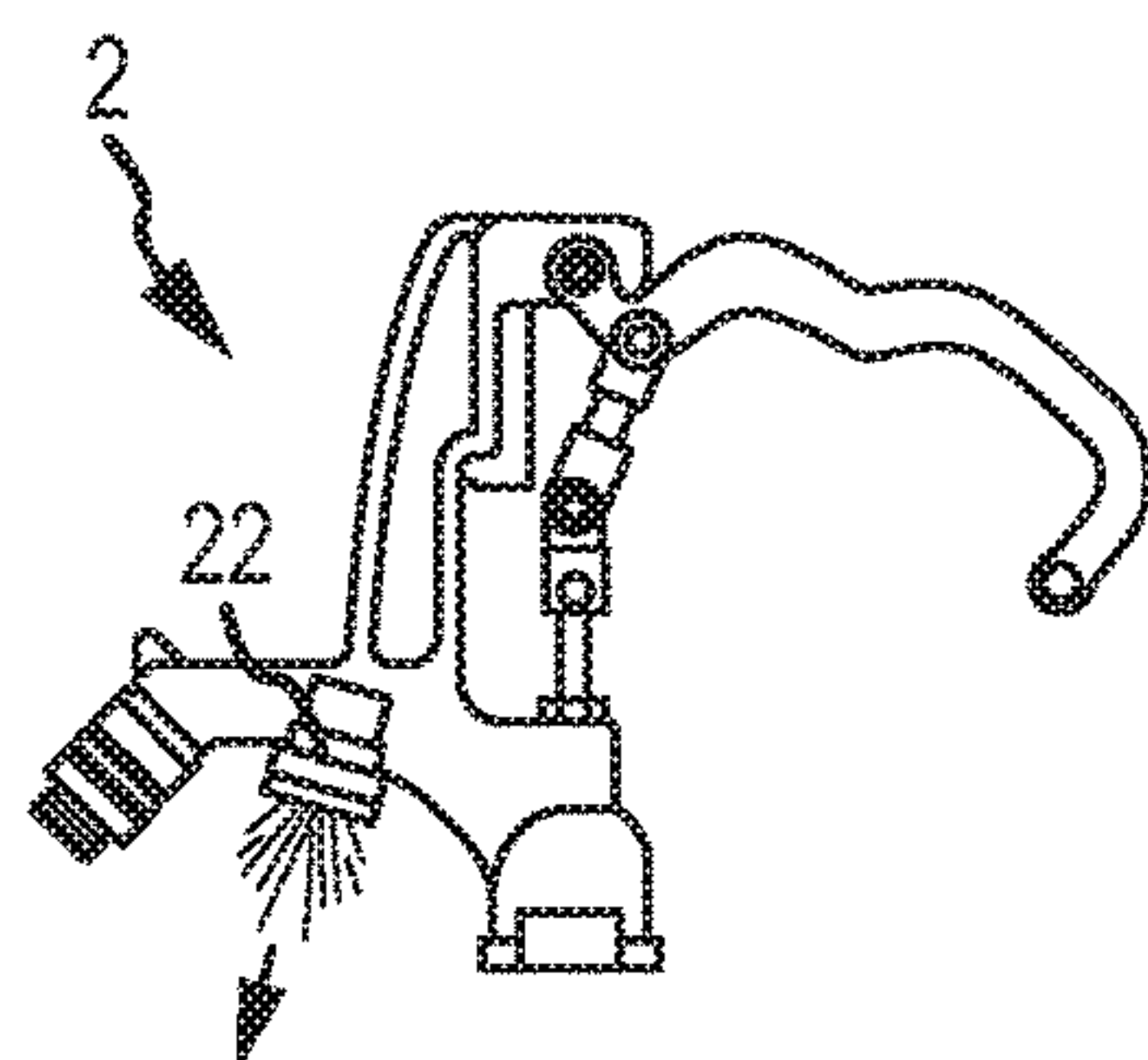

FIG. 1A
(PRIOR ART)
AMENDED

FIG. 1B
(PRIOR ART)
AMENDED

FIG. 1C
(PRIOR ART)
AMENDED



HYDRANT ON.
FLOW THROUGH DIVERTER.

FIG.2A
(PRIOR ART) AMENDED

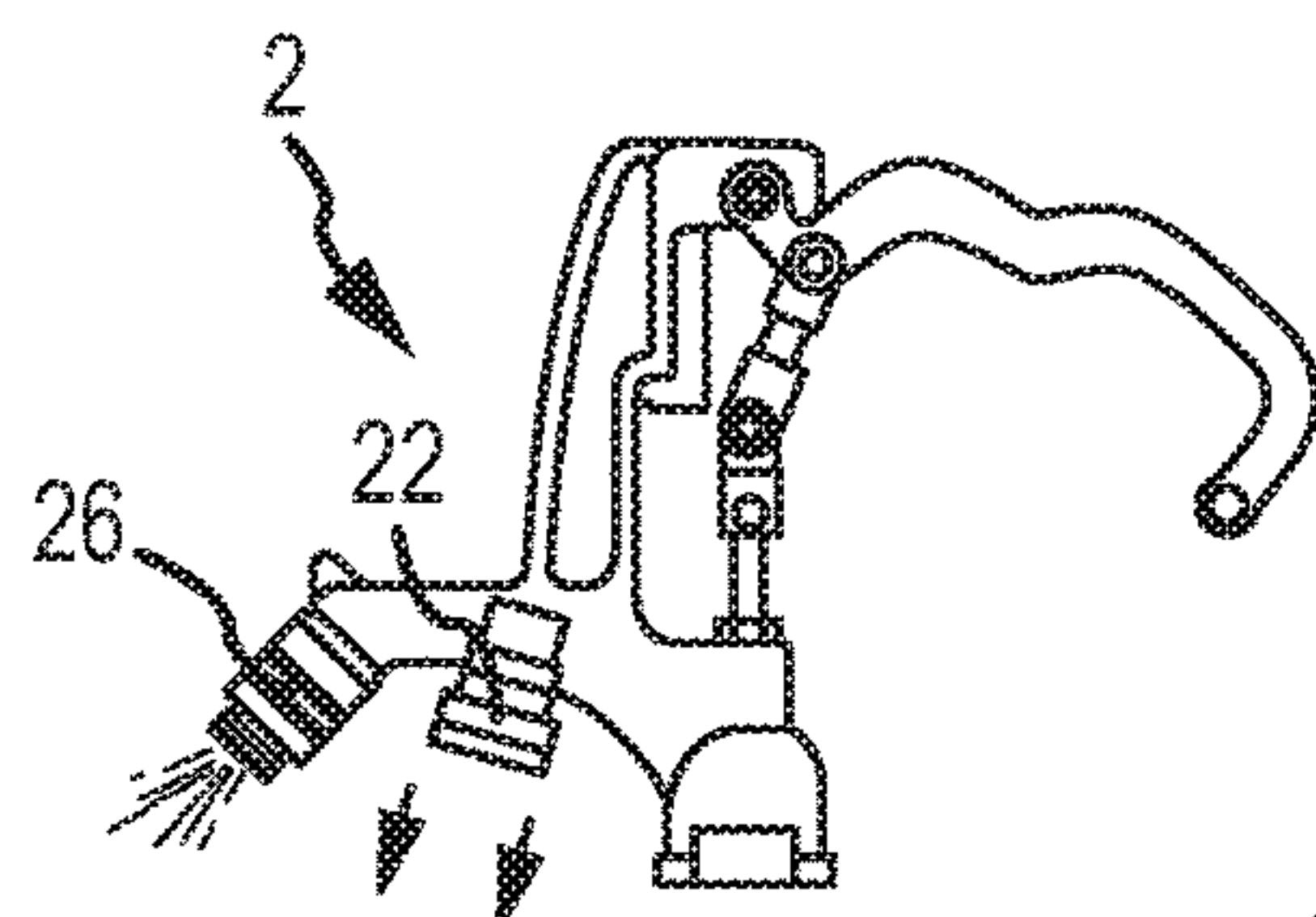

PULL DOWN

WATER DIVERTED THROUGH BACKFLOW PREVENTER

FIG.2B
(PRIOR ART) AMENDED

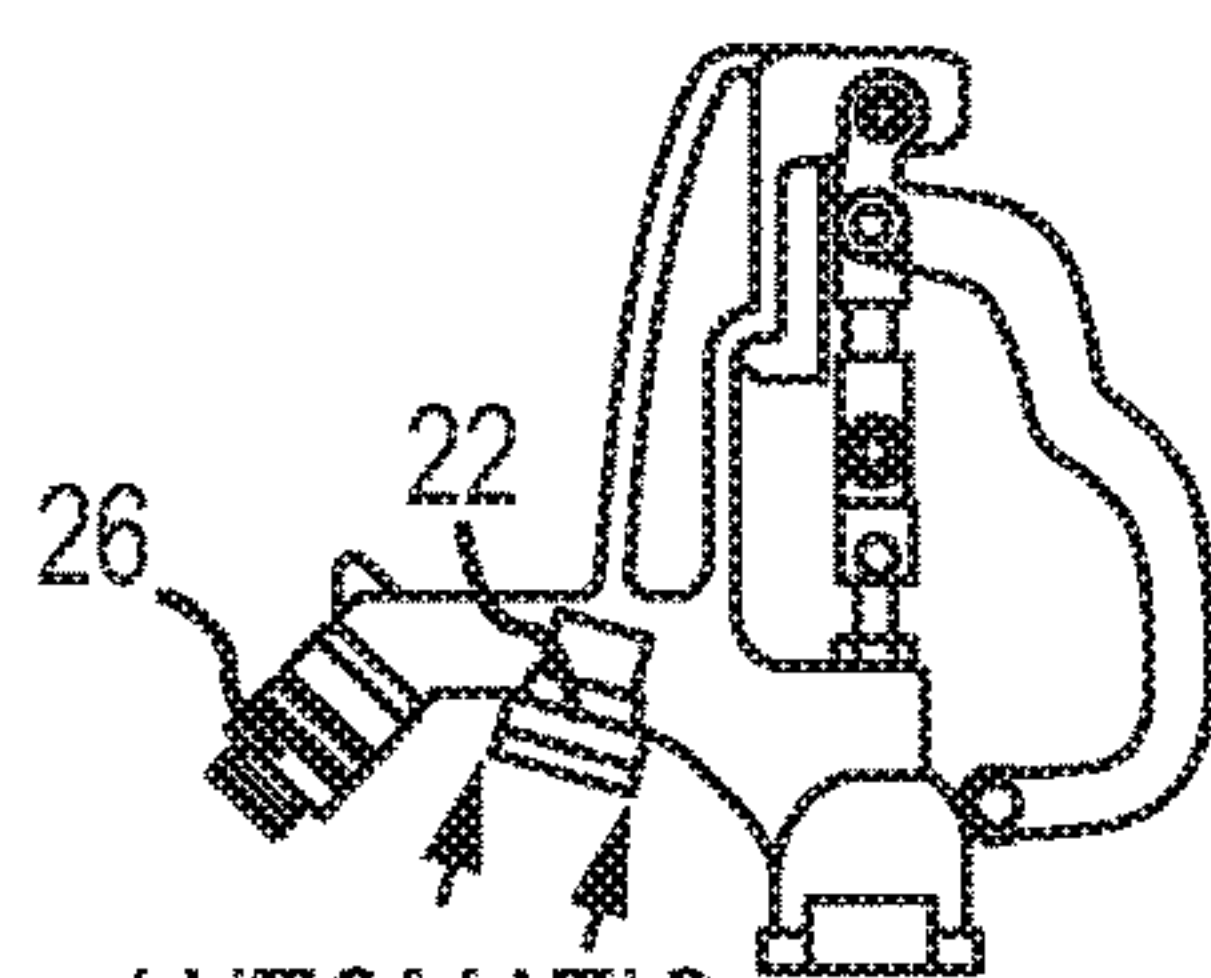

AUTOMATIC
RELEASE

HYDRANT OFF.
HYDRANT DRAINING INTO RESERVOIR

FIG.2C
(PRIOR ART) AMENDED

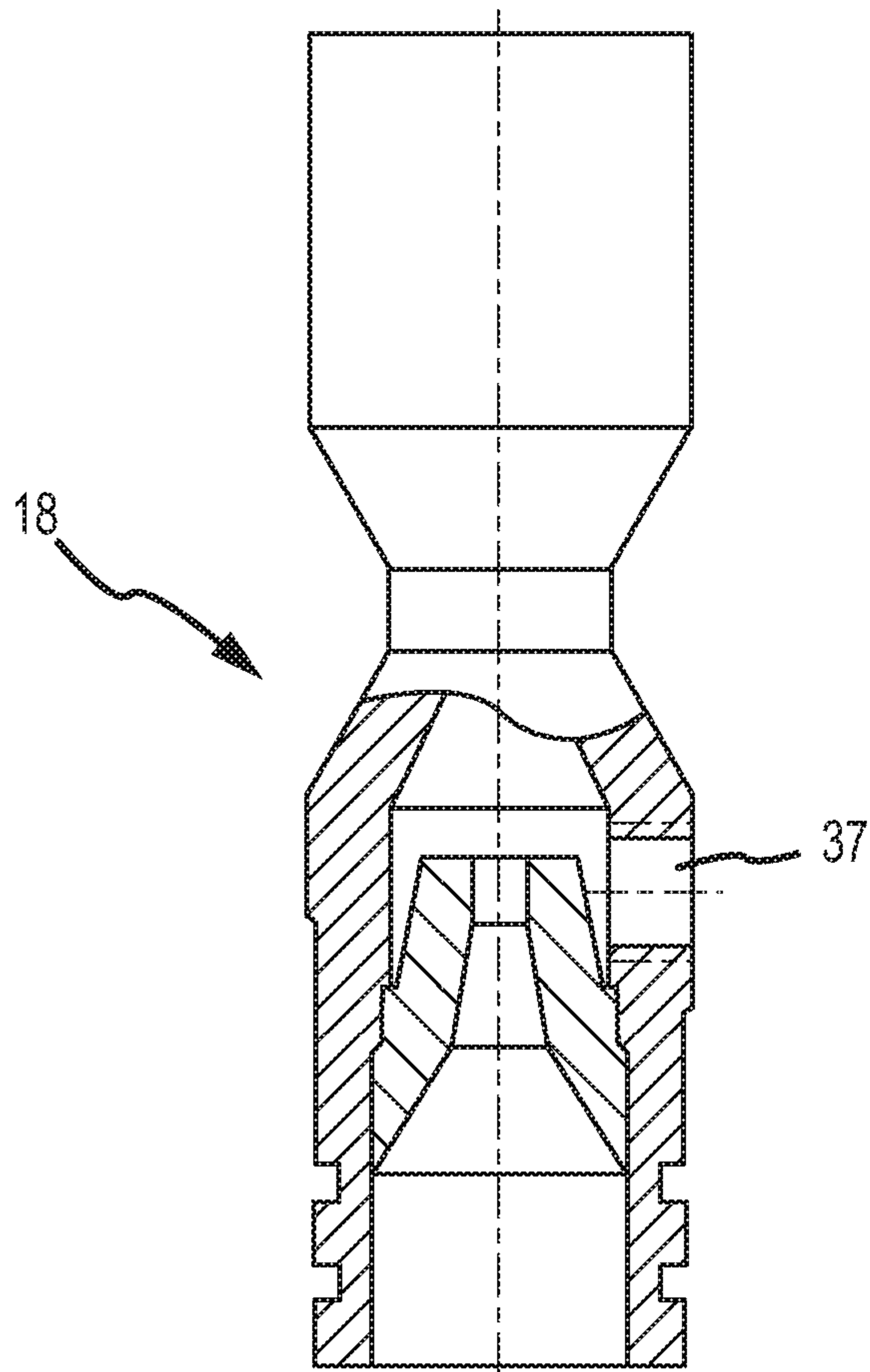

FIG.3
(PRIOR ART)

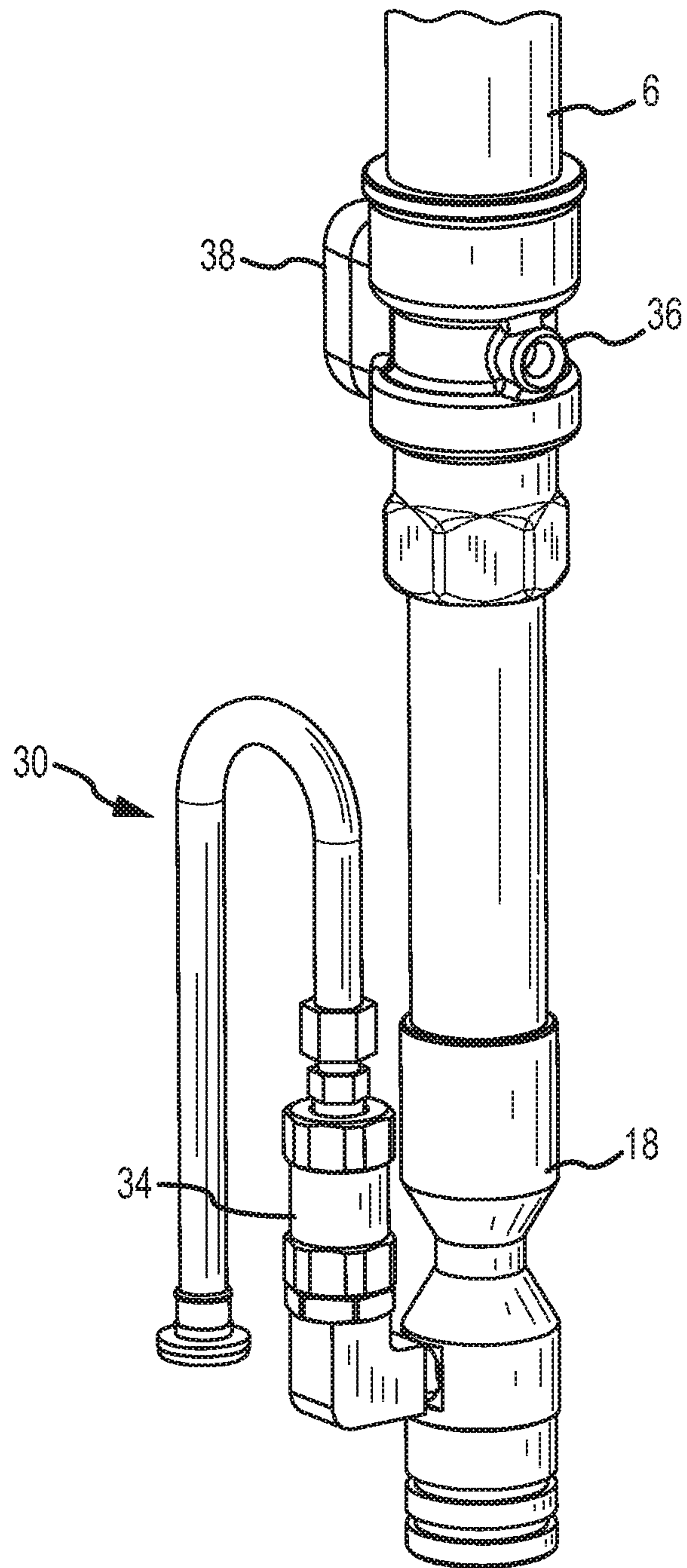

FIG. 4
(PRIOR ART)

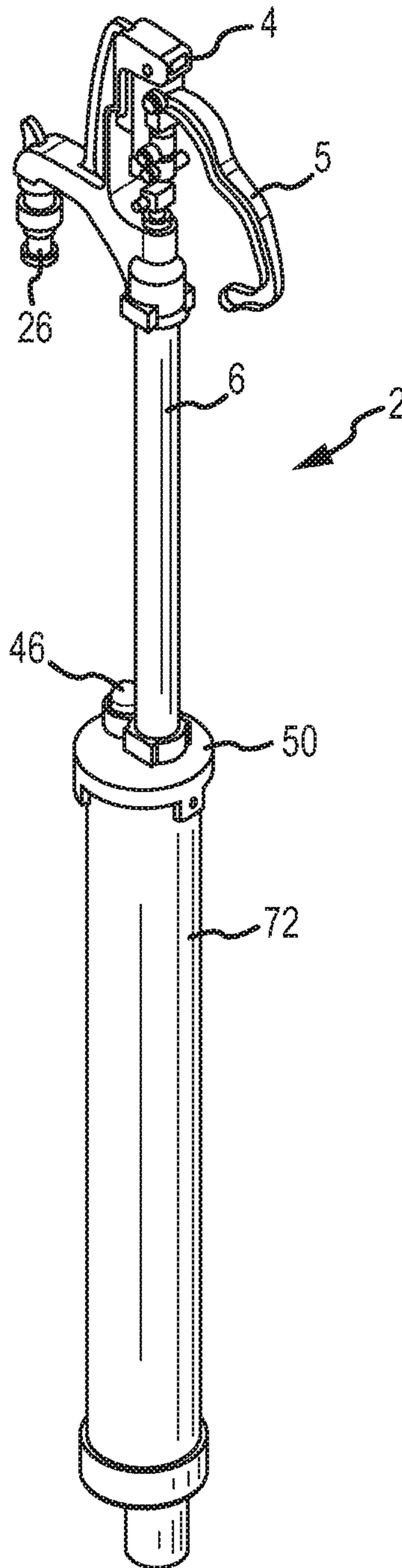

FIG. 5

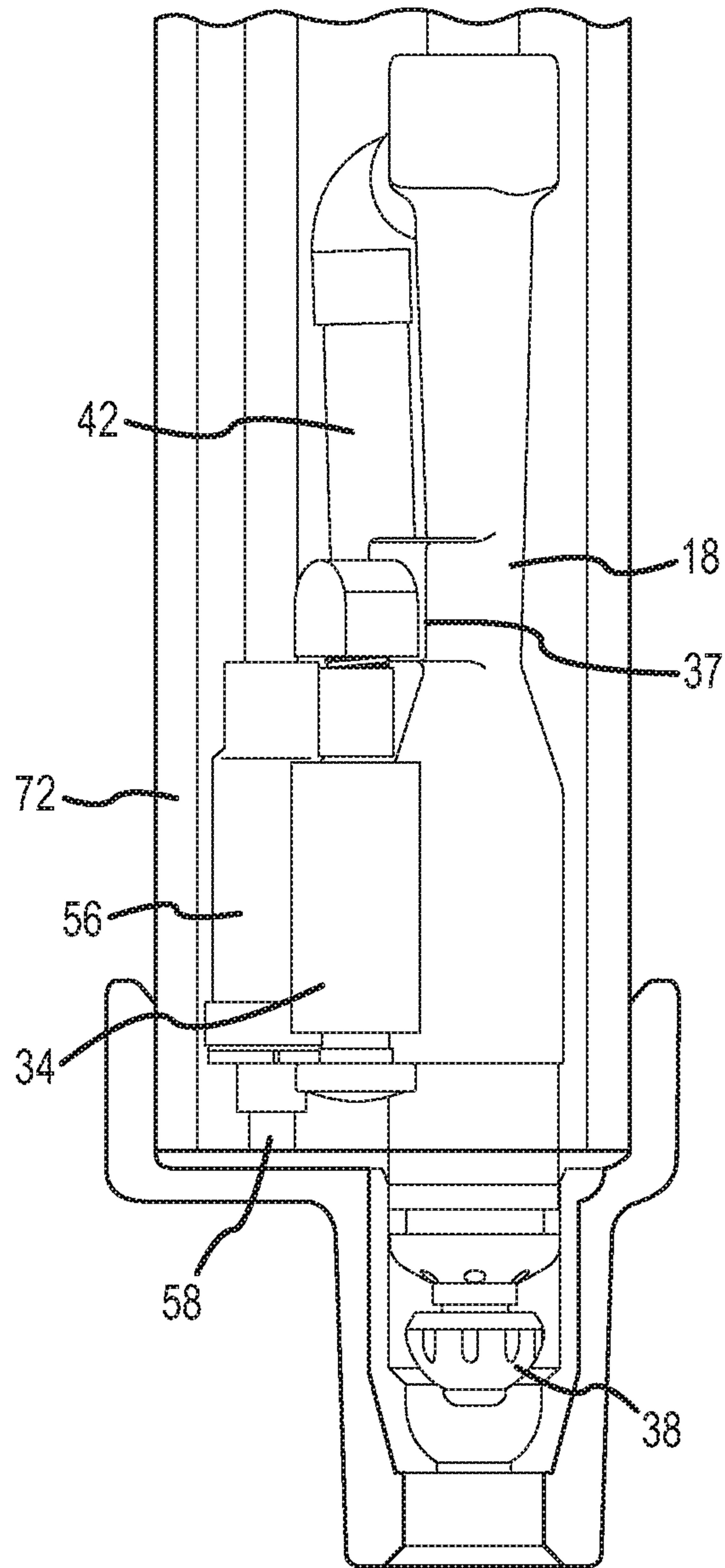

FIG. 6

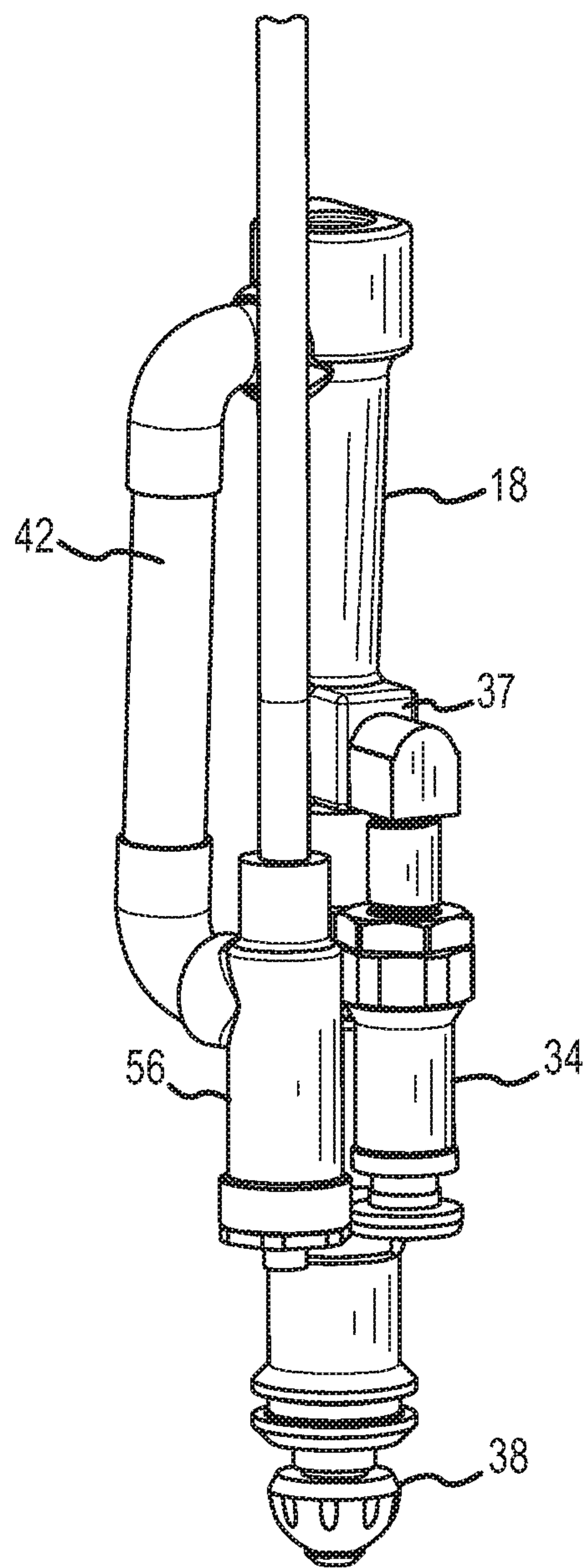

FIG. 7

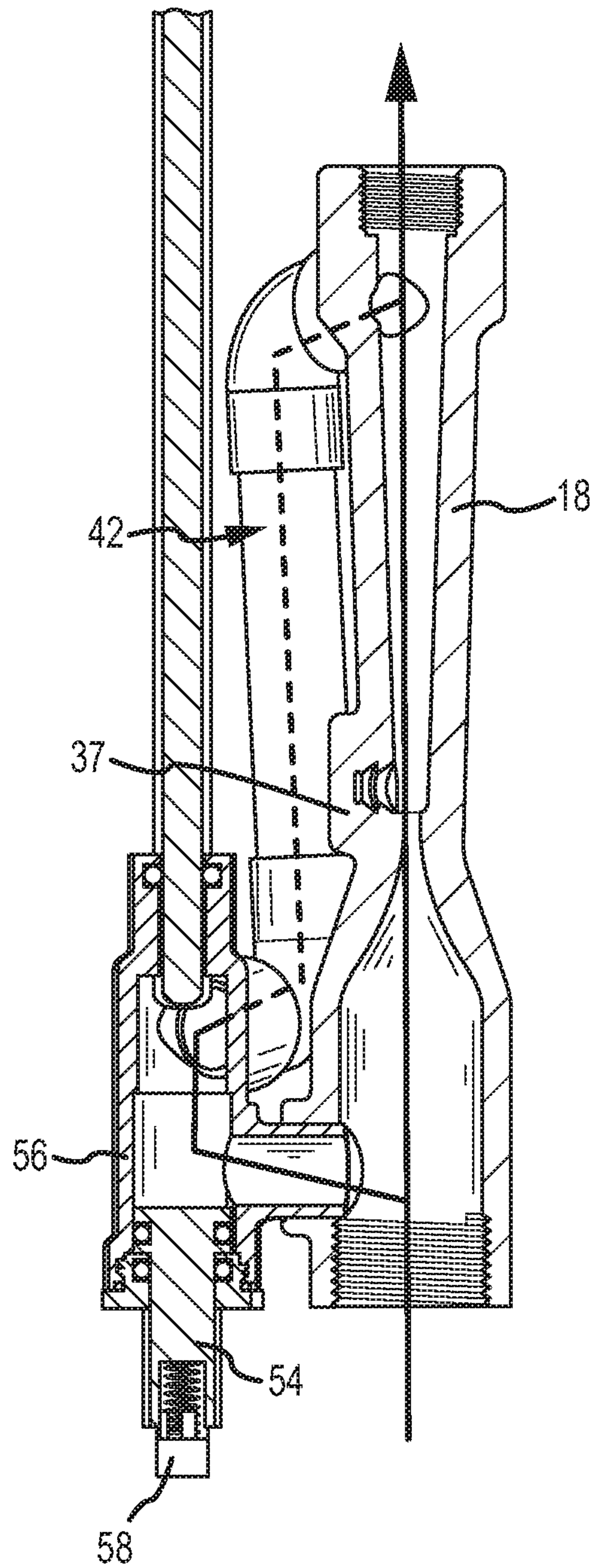

FIG. 8

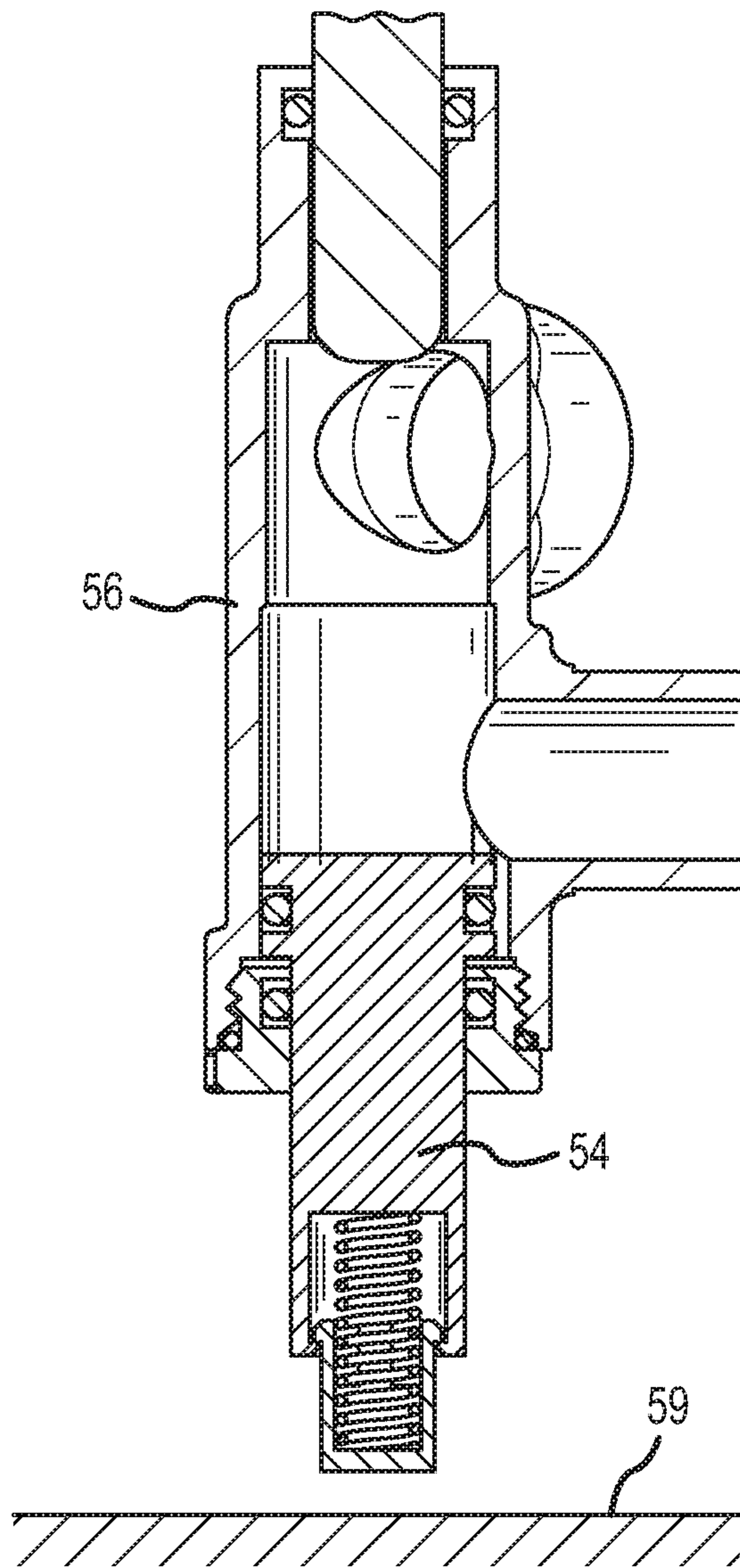

FIG. 9

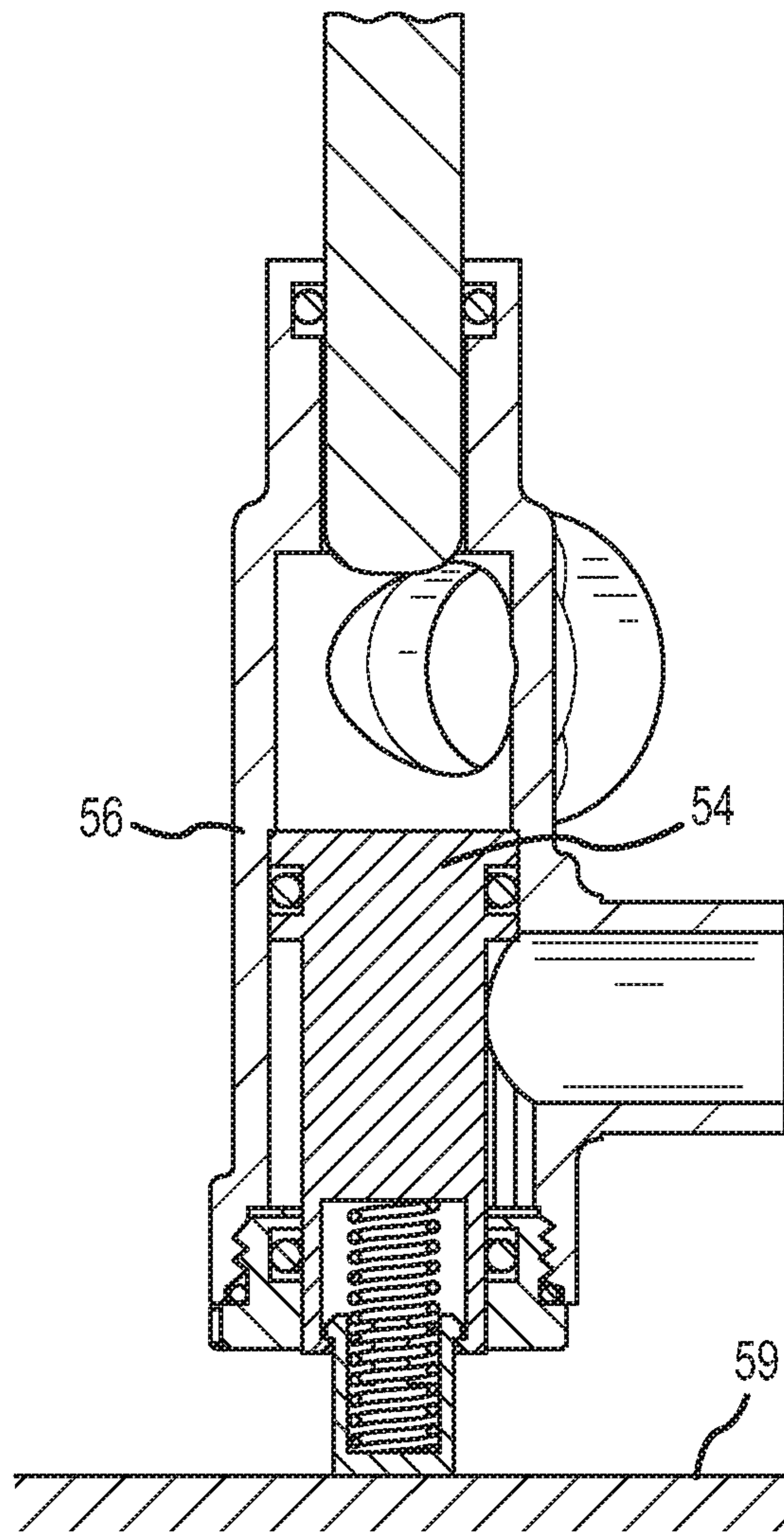

FIG. 10

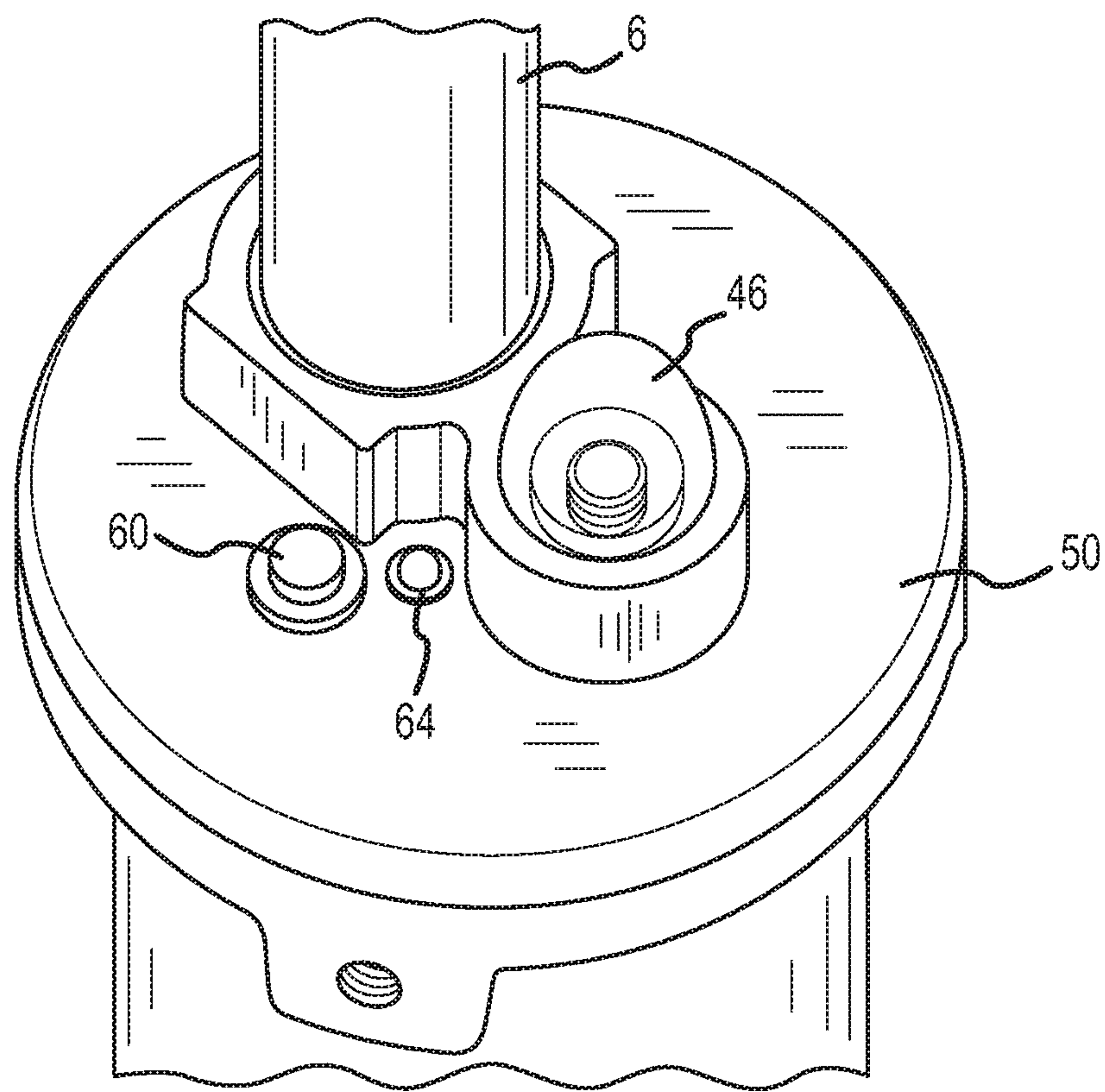

FIG. 11

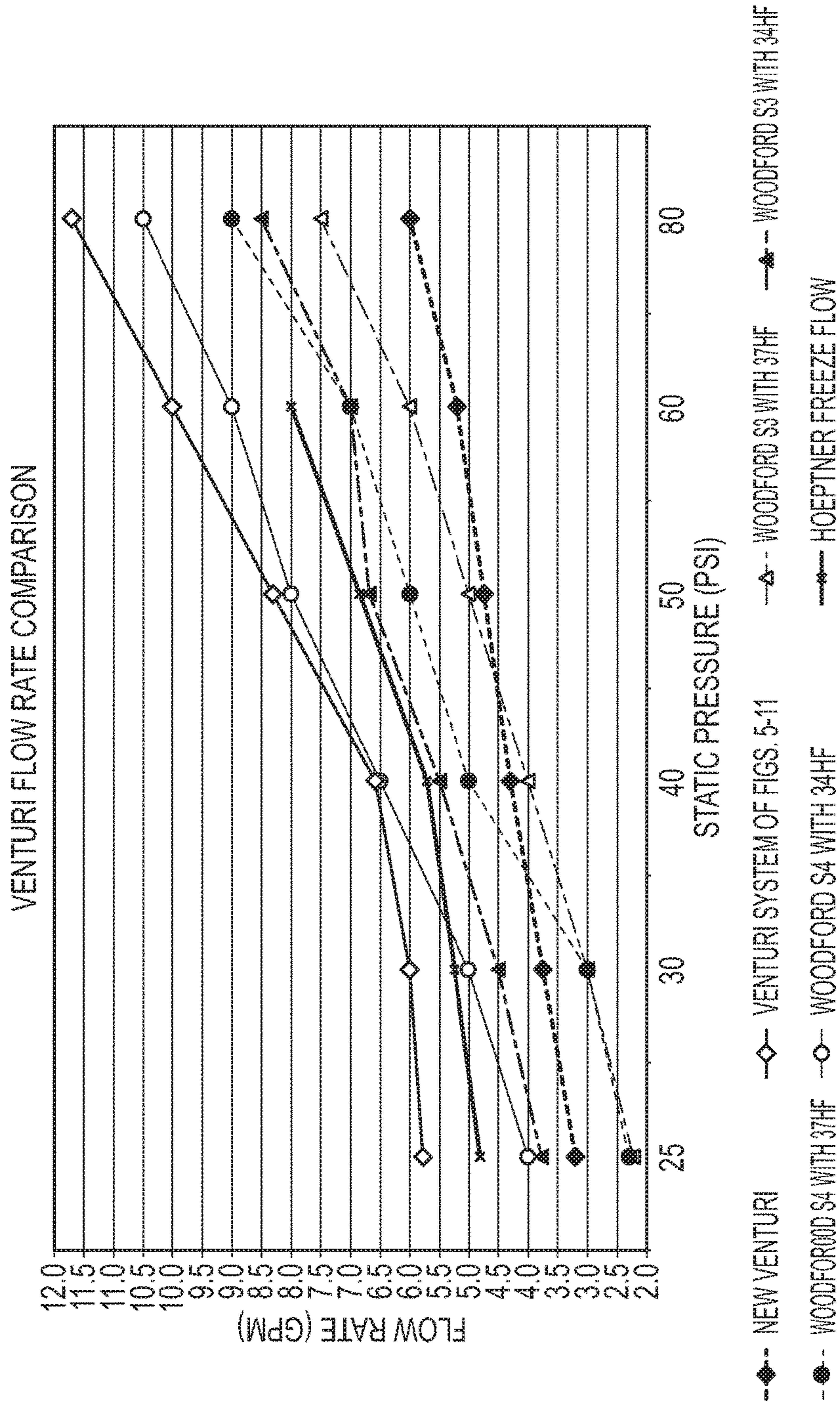

FIG.12

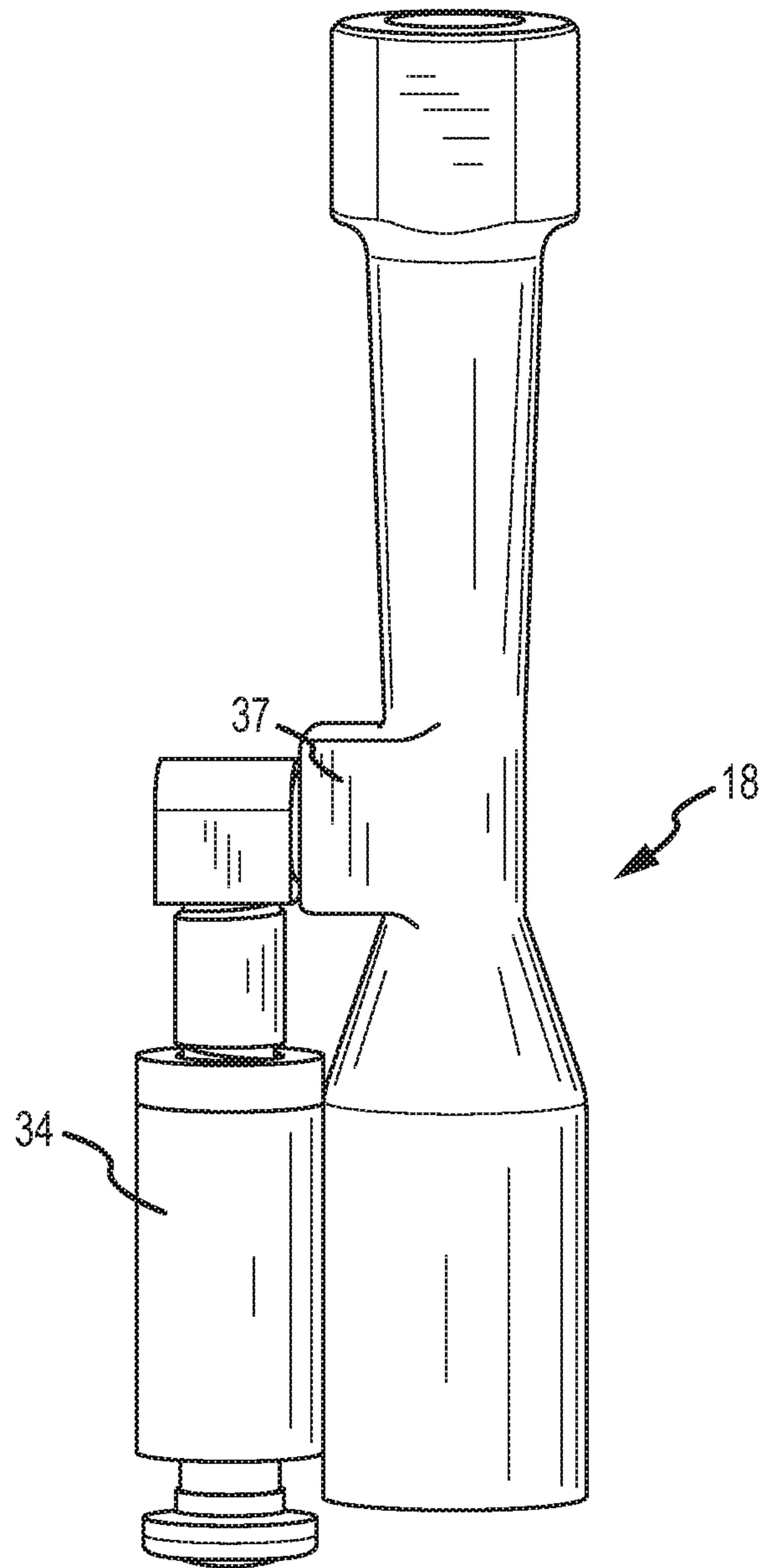

FIG. 13

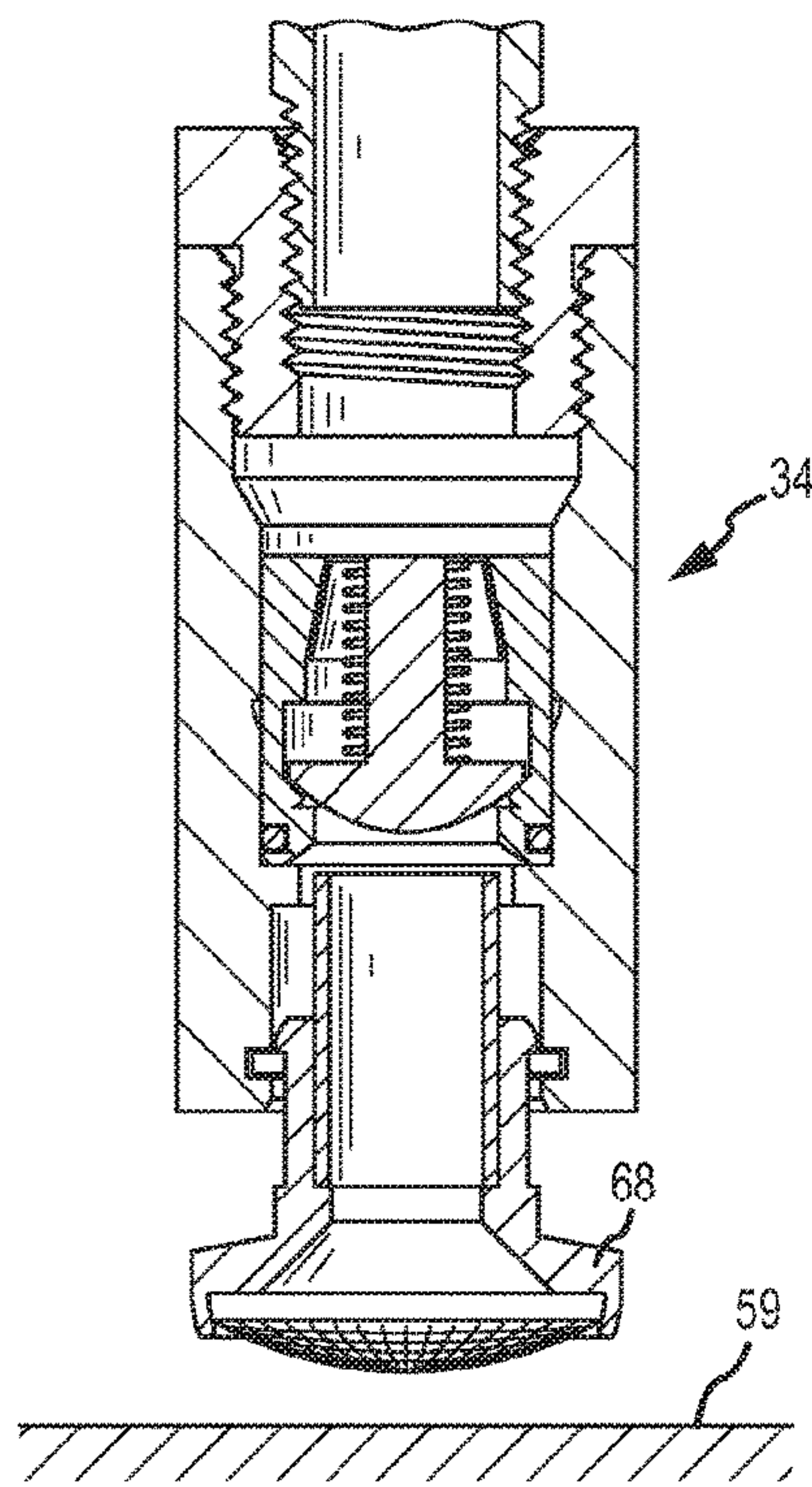

FIG. 14

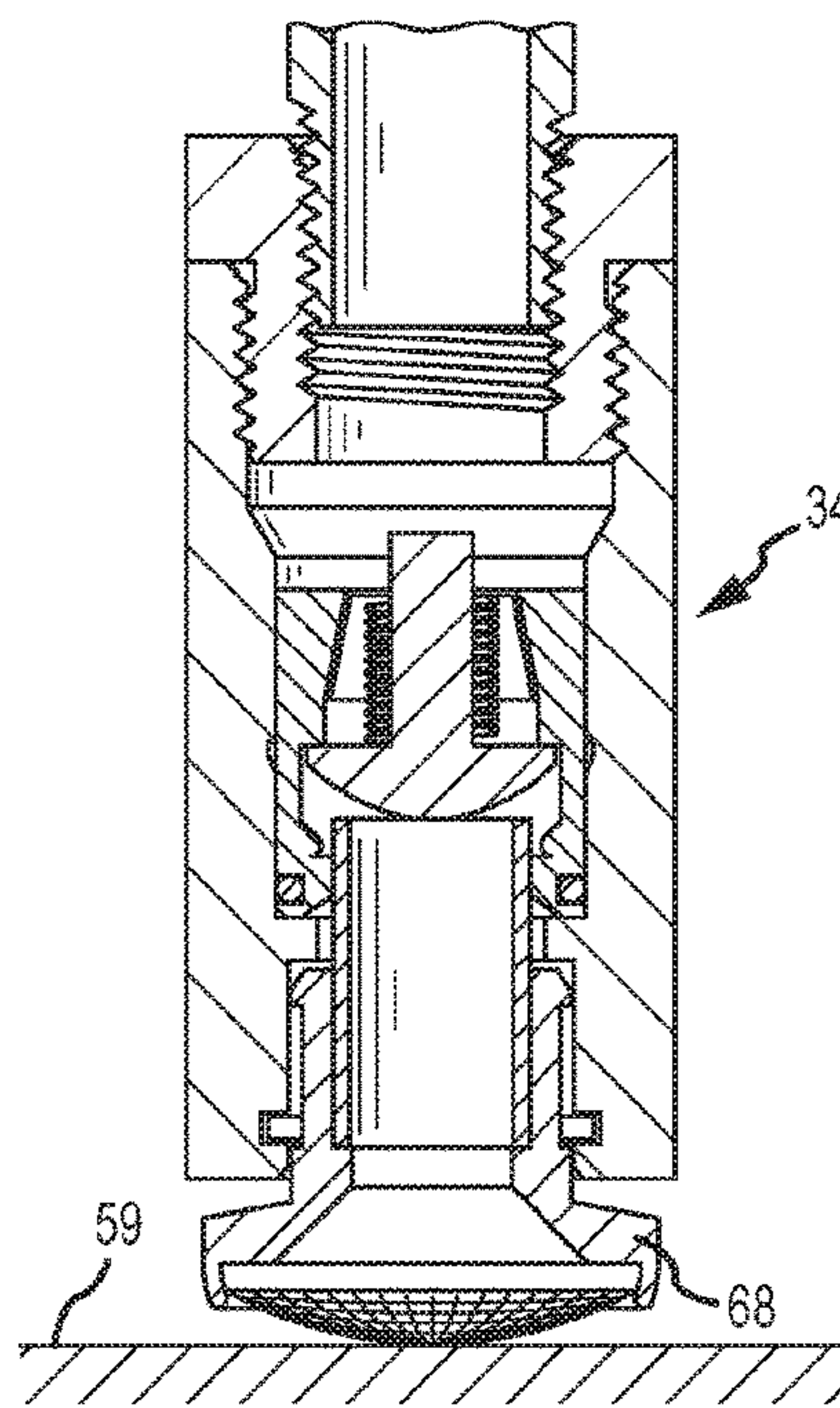

FIG. 15

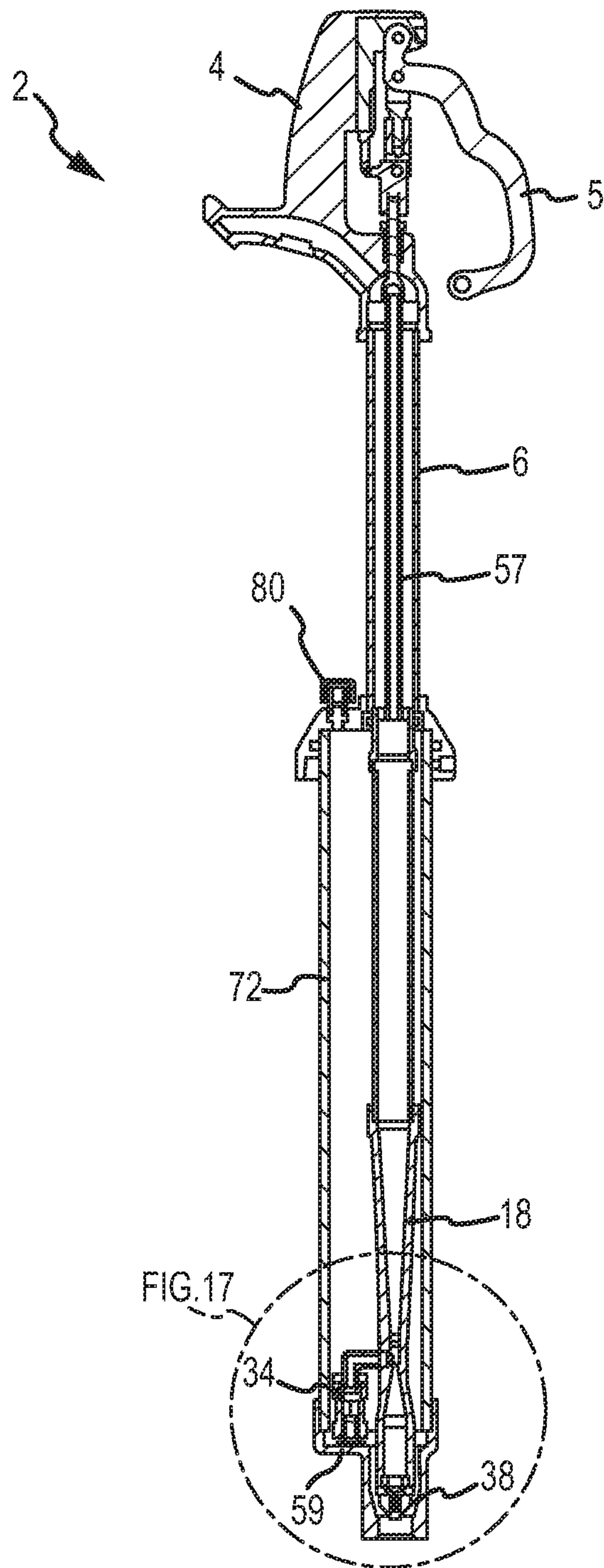

FIG. 16

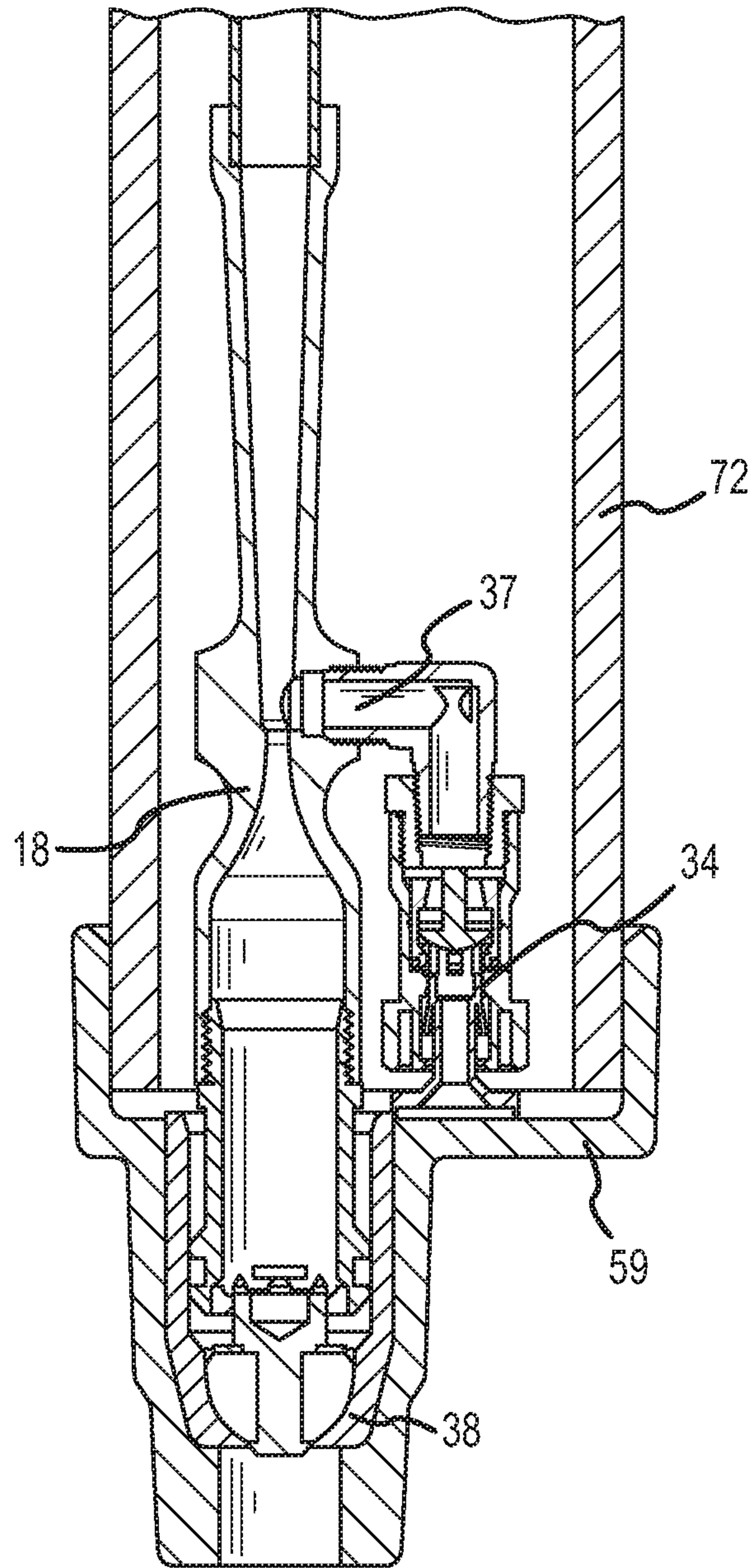

FIG. 17

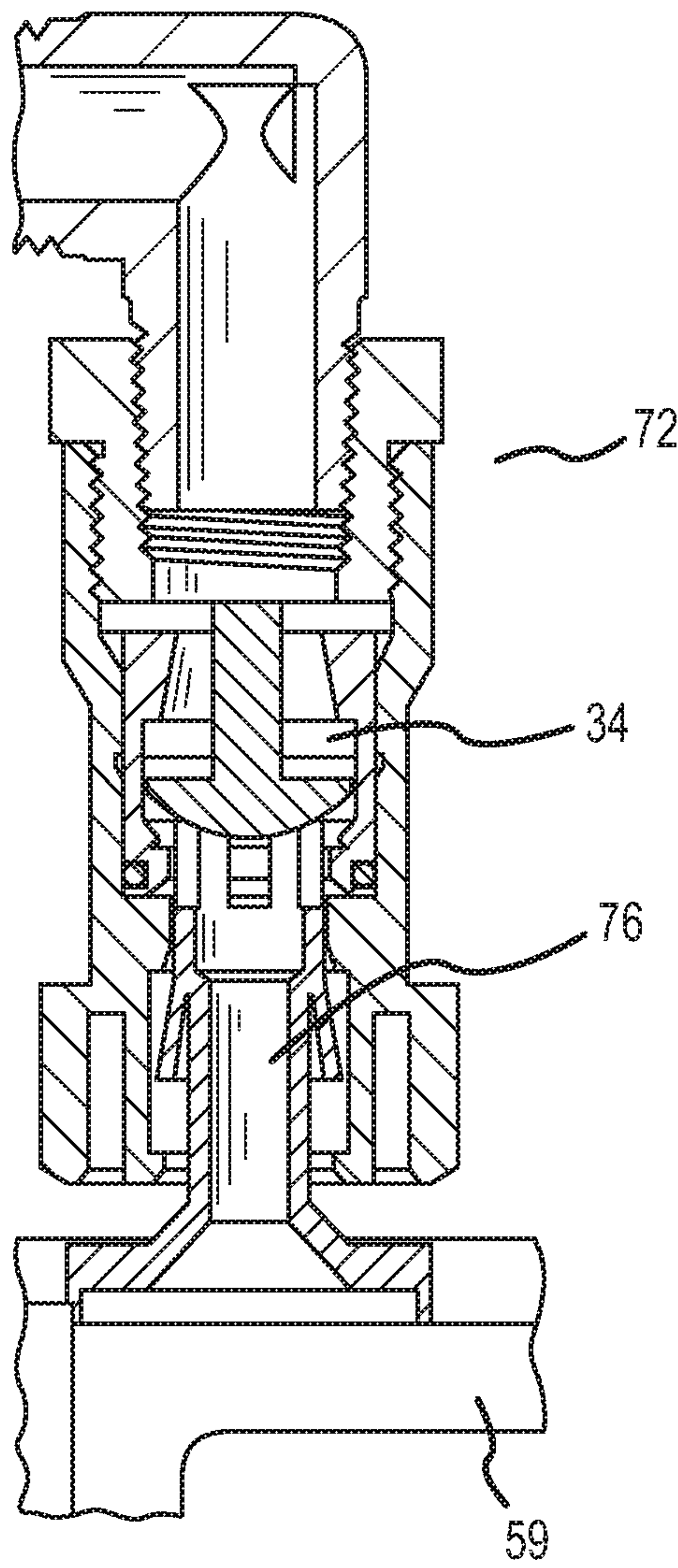

FIG. 18

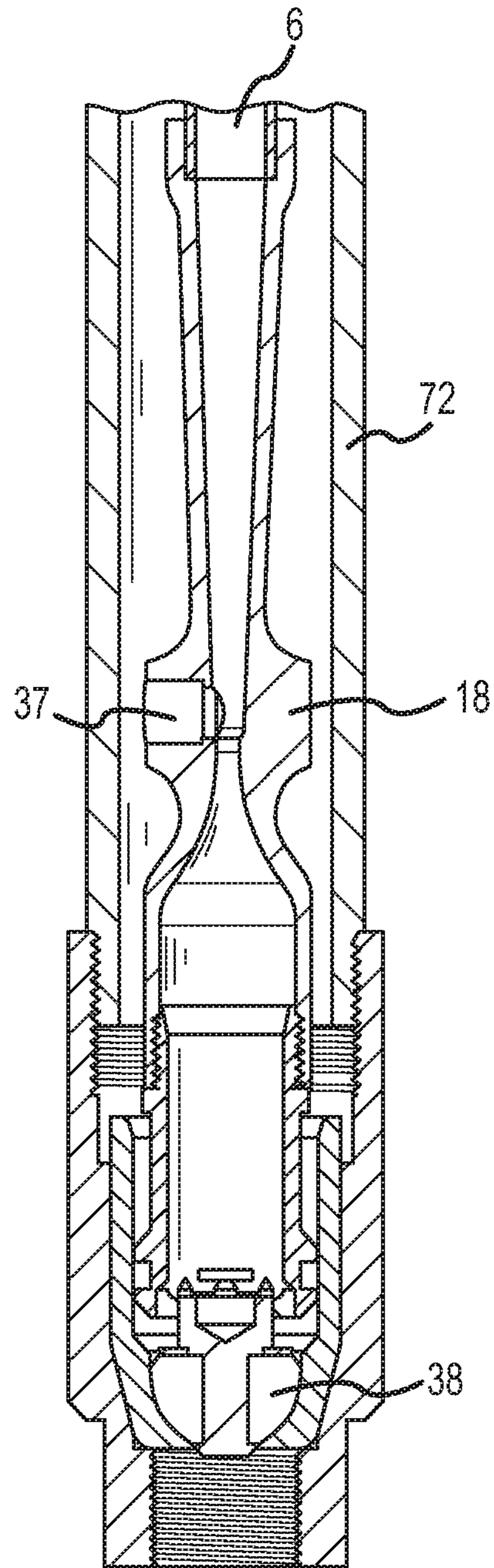

FIG. 19

	WOODFORD S3	WOODFORD S4H	FIGS.5-11	FIGS.16-18	FIG.19
VACUUM BREAKER USED TO PASS ASSE 1057	34HF	34HF	DC 50 HF	DC 50 HF	DC 50 HF
OPERATION CYCLE	1) TURN ON AND EVACUATE 30 SECONDS 2) RUN THOROUGH HOSE 3) SHUT OFF	1) TURN ON RUN THROUGH HOSE 2) SHUT OFF 3) TURN ON AND EVACUATE 30 SECONDS 4) SHUT OFF	1) TURN ON RUN THROUGH HOSE 2) SHUT OFF AND REMOVE HOSE 3) TURN ON AND EVACUATE 30 SECONDS 4) SHUT OFF	1) TURN ON RUN THROUGH HOSE 2) SHUT OFF AND REMOVE HOSE 3) TURN ON AND EVACUATE 15 SECONDS 4) SHUT OFF	1) TURN ON RUN THROUGH HOSE 2) SHUT OFF AND REMOVE HOSE 3) TURN ON AND EVACUATE 30 SECONDS 4) SHUT OFF
DRAIN TO RESERVOIR WITH HOSE ATTACHED	YES	YES	NO	NO	NO
WORK WITH SPRAY NOZZLE ATTACHED	YES	YES	YES	YES	YES
OPERATIONAL STEP OF WHEN TO EVACUATE RESERVOIR, WITH HOSE ATTACHED	FIRST OR LAST	LAST	LAST	LAST	LAST
SPECIAL INSTRUCTIONS	EVACUATE RESERVOIR ONLY THROUGH DIVERTER	EVACUATE RESERVOIR ONLY THROUGH DIVERTER	EVACUATE WITHOUT HIGH FLOW BUT ON PUSHED OR HOSE ATTACHED	EVACUATE WITHOUT HOSE ATTACHED	EVACUATE WITHOUT HOSE ATTACHED
PVC RISER	4"	3"	3"	3"	1 1/2"
FLOW RATE @ 60 PSI (1057 APPROVED HYDRANT)	7	7	8.4	6.2	6
HEAD USED	WOODFORD Y2	WOODFORD S4H	WOODFORD Y34	WOODFORD W34	WOODFORD Y34
# OF O-RINGS IN DESIGN	3	2	5	3	2
# OF STATIC SEAL O-RINGS IN DESIGN	2	2	1	0	0
MAXIMUM BURY DEPTH	7'	7'	7'	5'	2'
MINIMUM OPERATION PRESSURE	20 PSI	20 PSI	20 PSI	40 PSI	25 PSI
ADA COMPLAINT	NO	YES	NO	NO	NO
INLET SIZE	1"	1"	3/4"	1/2"	1/2"
TIME TO EVACUATE RESERVOIR @MAX BURY AND MIN PSI	45	45	30	15	30

FIG.20

SANITARY HYDRANT

Matter enclosed in heavy brackets [] appears in the original patent but forms no part of this reissue specification; matter printed in italics indicates the additions made by reissue; a claim printed with strikethrough indicates that the claim was canceled, disclaimed, or held invalid by a prior post-patent action or proceeding.

This application is a reissue of U.S. patent application Ser. No. 14/988,600, filed Jan. 5, 2016, issued as U.S. Pat. No. 9,593,471, which is a continuation of U.S. patent application Ser. No. 14/623,730, filed Feb. 17, 2015, now U.S. Pat. No. 9,228,327, which is a continuation of U.S. patent application Ser. No. 13/933,264, filed Jul. 2, 2013, now U.S. Pat. No. 8,955,538, which is a continuation of U.S. patent application Ser. No. 13/048,445, filed Mar. 15, 2011, now U.S. Pat. No. 8,474,476, which claims the benefit of U.S. Provisional Patent Application Ser. No. 61/313,902, filed Mar. 15, 2010, and U.S. Provisional Patent Application Ser. No. 61/313,918, filed Mar. 15, 2010, the entire disclosures of which are incorporated by reference herein. To the extent appropriate, a claim for priority is made to each of the above-recited applications.

This application is also related to U.S. Pat. No. 8,042,565, U.S. Pat. No. 7,472,718, and U.S. Pat. No. 7,730,901, the entire disclosures of which are incorporated by reference herein.

The owner, WCM Industries, Inc., with a 100% percent interest in the instant application hereby disclaims, except as provided below, the terminal part of the statutory term of any patent granted on the instant application which would extend beyond the expiration date of the full statutory term of the prior U.S. Pat. No. 8,474,476 as the term of said prior patent is presently shortened by any terminal disclaimer. The owner hereby agrees that any patent so granted on the instant application shall be enforceable only for and during such period that it and the prior patent are commonly owned. This agreement runs with any patent granted on the instant application and is binding upon the grantee, its successors or assigns.

In making the above disclaimer, the owner does not disclaim the terminal part of the term of any patent granted on the instant application that would extend to the expiration date of the full statutory term of the prior patent, "as the term of said prior patent is presently shortened by any terminal disclaimer," in the event that said prior patent later:

*expires for failure to pay a maintenance fee;
is held unenforceable;
is found invalid by a court of competent jurisdiction;
is statutorily disclaimed in whole or terminally disclaimed under 37 CFR 1.321;
has all claims canceled by a reexamination certificate;
is reissued; or
is in any manner terminated prior to the expiration of its full statutory term as presently shortened by any terminal disclaimer.*

FIELD OF THE INVENTION

Embodiments of the present invention are generally related to contamination proof hydrants that employ a venturi that facilitates transfer of fluid from a self-contained water storage reservoir.

BACKGROUND OF THE INVENTION

Hydrants typically comprise a head interconnected to a water source by way of a vertically oriented standpipe that is buried in the ground or interconnected to a fixed structure, such as a roof. To be considered "freeze proof" hydrant water previously flowing through the standpipe must be directed away from the hydrant after shut off. Thus many ground hydrants currently in use allow water to escape from the standpipe from a drain port located below the "frost line" as shown in FIG. 1.

Hydrants are commonly used to supply water to livestock that will urinate and defecate in areas adjacent to the hydrant. It follows that the animal waste will leach into the ground. Thus a concern with freeze proof hydrants is that they may allow contaminated ground water to penetrate the hydrant through the drain port when the hydrant is shut off. More specifically, if a vacuum, i.e., negative pressure, is present in the water supply, contaminated ground water could be drawn into the standpipe and the associated water supply line. Contaminants could also enter the system if pressure of the ground water increases. To address the potential contamination issue, "sanitary" yard hydrants have been developed that employ a reservoir that receives water from the standpipe after hydrant shut off.

There is a balance between providing a freeze proof hydrant and a sanitary hydrant that is often difficult to address. More specifically, the water stored in the reservoir of a sanitary hydrant could freeze which can result in hydrant damage or malfunction. To address this issue, attempts have been made to ensure that the reservoir is positioned below the frost line or located in an area that is not susceptible to freezing. These measures do not address the freezing issue when water is not completely evacuated from the standpipe. That is, if the reservoir is not adequately evacuated when the hydrant is turned on, the water remaining in the reservoir will effectively prevent standpipe water evacuation when the hydrant is shut off, which will leave water above the frost line.

To help ensure that all water is evacuated from the reservoir, some hydrants employ a venturi system. A venturi comprises a nozzle and a decreased diameter throat. When fluid flows through the venturi a pressure drop occurs at the throat that is used to suction water from the reservoir. That is, the venturi is used to create an area of low pressure in the fluid inlet line of the hydrant that pulls the fluid from the reservoir when fluid flow is initiated. Sanitary hydrants that employ venturis must comply with ASSE-1057, ASSE-0100, and ASSE-0152 that require that a vacuum breaker or a backflow preventer be associated with the hydrant outlet to counteract negative pressure in the hydrant that may occur when the water supply pressure drops from time-to-time which could draw potentially contaminated fluid into the hydrant after shut off. Internal flow obstructions associated with the vacuum breakers and backflow preventers will create a back pressure that will affect fluid flow through the hydrant. More specifically, common vacuum breakers and backflow preventers employ at least one spring-biased check valve. When the hydrant is turned on spring forces are counteracted and the valve is opened by the pressure of the fluid supply, which negatively influences fluid flow through the hydrant. In addition an elongated standpipe will affect fluid flow. These sources of back pressure influence flow through the venturi to such a degree that a pressure drop sufficient to remove the stored water from the reservoir will not be created. Thus to provide fluid flow at a velocity required for proper functioning of the venturi, fluid diverters

or selectively detachable backflow preventers, i.e., those having a quick disconnect capability, have been used to avoid the back pressure associated with the vacuum breakers of backflow preventers. In operation, as shown in FIG. 2, the diverter is used initially for about 45 seconds to ensure reservoir evacuation. Then, the diverter is disengaged so that the water will flow through the backflow preventer or vacuum breaker. The obvious drawback of this solution is that the diverter must be manually actuated and the user must allow water to flow for a given amount of time, which is wasteful.

Further, as the standpipe gets longer it will create more backpressure, i.e., head pressure, that reduces the flow of water through the venturi, and at some point a venturi of any design will be unable to evacuate the water in the reservoir. That is, the amount of time it takes for a hydrant to evacuate the water into the reservoir depends on the height/length of the standpipe as well as the water pressure. The evacuation time of roof hydrants of embodiments of the present invention, which has a 42" standpipe, is 5 seconds at 60 psi. The evacuation time will increase with a lower supply pressure or increased standpipe length or diameter. Currently existing hydrants have evacuation times in the 30 second range.

Another way to address the fluid flow problem caused by vacuum breakers is to provide a reservoir with a "pressure system" that is capable of holding a pressure vacuum that is used to suction water from the standpipe after hydrant shut off. During normal use the venturi will evacuate at least a portion of the fluid from the reservoir. Supply water is also allowed to enter the reservoir which will pressurize any air in the reservoir that entered the reservoir when the reservoir was at least partially evacuated. When flow through the hydrant is stopped, the supply pressure is cut off and the air in the reservoir expands to create a pressure drop that suctions water from the standpipe into the reservoir. If the vacuum produced is insufficient, which would be attributed to incomplete evacuation of the reservoir, water from the standpipe will not drain into the reservoir and water will be left above the frost line.

Other hydrants employ a series of check valves to prevent water from entering the reservoir during normal operations. Hydrants that employ a "check system" uses a check valve to allow water into or out of the reservoir. When the hydrant is turned on, the check valve opens to allow the water to be suctioned from the reservoir. The check also prevents supply water from flowing into the reservoir during normal operations, which occurs during the operation of the pressure vacuum system. When the hydrant is shut off, the check valve opens to allow the standpipe water to drain into the reservoir. One disadvantage of a check system is that it requires a large diameter reservoir to accommodate the check valve. Thus a roof hydrant would require a larger roof penetration and a larger hydrant mounting system, which may not be desirable.

Another issue associated with both the pressure vacuum and check systems is that there must be a passageway or vent that allows air into the reservoir so that when a hydrant is turned on, the water stored in the reservoir can be evacuated. If the reservoir was not exposed to atmosphere, the venturi would not create sufficient suction to overcome the vacuum that is created in the reservoir.

SUMMARY OF THE INVENTION

It is one aspect of embodiments of the present invention to provide a sanitary and freeze proof hydrant that employs a venturi for suctioning fluid from a fluid storage reservoir.

As one of skill in the art will appreciate, the amount of suction produced by the venturi is a function of geometry. More specifically, the contemplated venturi is comprised of a nozzle with an associated throat. Water traveling through the nozzle creates an area of low pressure at or near the throat that is in fluid communication with the reservoir. In one embodiment, the configuration of the nozzle and throat differs from existing products. That is, the contemplated nozzle is configured such that the venturi will operate in conjunction with a vacuum breaker, a double check backflow preventer, or a double check backflow prevention device as disclosed in U.S. Patent Application Publication No. 2009/0288722, which is incorporated by reference in its entirety herein, without the need for a diverter. Preferably, embodiments of the present invention are used in conjunction with the double check backflow prevention device of the '722 publication as it is less disruptive to fluid flow than the backflow preventers and vacuum breakers of the prior art.

While the use of a venturi is not new to the sanitary yard hydrant industry, the design features of the venturi employed by embodiments of the present invention are unique in the way freeze protection is provided. More specifically, current hydrants employ a system that allows water to bypass a required vacuum breaker. For example, the Hoepfner Freeze Flow Hydrant employs a detachable vacuum breaker and the Woodford Model S3 employs a diverter. Again, fluid diversion is needed so that sufficient fluid flow is achieved for proper venturi functions. The venturi design of sanitary hydrants of the present invention is unique in that the venturi will function properly when water flows through the vacuum breaker or double check backflow preventer—no fluid diversion at the hydrant head is required. This allows the hydrant to work in a way that is far more user friendly, because the hydrant is able to maintain its freeze resistant functionality without requiring the user to open a diverter, for example. Embodiments of the present invention are also environmentally friendly as resources are conserved by avoiding flowing water out of a diverter.

It is another aspect of the embodiments of the invention is to provide a hydrant that operates at pressures from about 20 psi to 125 psi and achieves a mass flow rate above 3 gallons per minute (GPM) at 25 psi, which is required by code. One difficult part of optimizing the flow characteristics to achieve these results is determining the nozzle diameter. It was found that a throat diameter change of about 0.040 inches would increase the mass flow rate by 2 GPM. That same change, however, affects the operation of the venturi. For example, hydrants with a nozzle diameter of 0.125 inches will provide acceptable reservoir evacuation but would not have the desired mass flow rate. A 0.147 inch diameter nozzle will provide an acceptable mass flow rate, but reservoir evacuation time was sacrificed. In one embodiment of the present invention a venturi having a nozzle diameter of about 0.160 inches is employed.

It is another aspect of the present invention to provide a nozzle having an exit angle that facilitates fluid flow through the venturi. More specifically, the nozzle exit of one embodiment possesses a gradual angle so that fluid flowing through the venturi maintains fluid contact with the surface of the nozzle and laminar flow is generally achieved. In one embodiment the exit angle is between about 4 to about 5.6 degrees. For example, nozzle exit having very gradual surface angle, e.g. 1-2 degrees, will evacuate the reservoir more quickly, but would require an elongated venturi. Thus, an elongated venturi may be used to reduce back pressure associated with the venturi, but doing so will add cost. The

nozzle inlet may have an angle that is distinct from that of the exit to facilitate construction of the venturi by improving the machining process.

It is thus one aspect of the present invention to provide a sanitary hydrant, comprising: a standpipe having a first end and a second end; a head for delivering fluid interconnected to said first end of said standpipe; a fluid reservoir associated with said second end of said standpipe; a venturi positioned within said reservoir and interconnected to said second end of said standpipe, said venturi comprised of a first end, which is interconnected to said standpipe, and a second end associated with a fluid inlet valve with a throat between said first end and said second end of said venturi; a bypass tube having a first end interconnected to a location adjacent to said first end of said venturi and a second end interconnected to a bypass valve, said bypass valve also associated with said second end of said venturi, wherein when said bypass valve is opened, fluid flows from said inlet valve, through said bypass tube, through said standpipe, and out said hydrant head; and wherein when said bypass valve is closed, fluid flows through said venturi, thereby creating a pressure drop adjacent to said throat that communicates with said reservoir to draw fluid therefrom.

It is another aspect to provide a method of evacuating a sanitary hydrant, comprising: providing a standpipe having a first end and a second end; providing a head for delivering fluid interconnected to said first end of said standpipe; providing a fluid reservoir associated with said second end of said standpipe; providing a venturi positioned within said reservoir and interconnected to said second end of said standpipe, said venturi comprised of a first end, which is interconnected to said standpipe, and a second end associated with a fluid inlet valve with a throat between said first end and said second end of said venturi; providing a bypass tube having a first end interconnected to a location adjacent to said first end of said venturi and a second end interconnected to a bypass valve, said bypass valve also associated with said second end of said venturi, wherein when said bypass valve is opened, fluid flows from said inlet valve, through said bypass tube, through said standpipe, and out said hydrant head; and wherein when said bypass valve is closed, fluid flows through said venturi, thereby creating a pressure drop adjacent to said throat that communicates with said reservoir to draw fluid therefrom initiating fluid flow through said head by actuating a handle associated therewith; actuating a bypass button that opens the bypass valve such that fluid is precluded from entering said venturi; actuating said bypass button to close said bypass valve; flowing fluid through said venturi; evacuating said reservoir; ceasing fluid flow through said hydrant; and draining fluid into said reservoir.

The Summary of the Invention is neither intended nor should it be construed as being representative of the full extent and scope of the present invention. Moreover, references made herein to "the present invention" or aspects thereof should be understood to mean certain embodiments of the present invention and should not necessarily be construed as limiting all embodiments to a particular description. The present invention is set forth in various levels of detail in the Summary of the Invention as well as in the attached drawings and the Detailed Description of the Invention and no limitation as to the scope of the present invention is intended by either the inclusion or non-inclusion of elements, components, etc. in this Summary of the Invention. Additional aspects of the present invention will become more readily apparent from the Detail Description, particularly when taken together with the drawings.

BRIEF DESCRIPTION OF THE DRAWINGS

The accompanying drawings, which are incorporated in and constitute a part of the specification, illustrate embodiments of the invention and together with the general description of the invention given above and the detailed description of the drawings given below, serve to explain the principles of these inventions.

FIGS. 1A-1C are a depiction of the operation of a hydrant of the prior art;

FIGS. 2A-2C are a series of figures depicting the use of a flow diverter of the prior art;

FIG. 3 is a cross section of a venturi of the prior art;

FIG. 4 is a perspective view of a venturi system employed by the prior art;

FIG. 5 is a perspective view of one embodiment of the present invention;

FIG. 6 is a detailed view of the venturi system of the embodiment of FIG. 5;

FIG. 7 is a perspective view similar to that of FIG. 6 wherein the reservoir has been omitted for clarity;

FIG. 8 is a cross sectional view of a venturi system that employs a bypass tube of one embodiment of the present invention;

FIG. 9 is a cross sectional view of a bypass valve used in conjunction with the embodiment of FIG. 5 shown in an open position;

FIG. 10 shows the bypass valve of FIG. 9 in a closed position;

FIG. 11 is a top perspective view of one embodiment of the present invention showing a bypass button and an electronic reservoir evacuation button;

FIG. 12 is a graph showing sanitary hydrant comparisons;

FIG. 13 is a perspective view of a venturi system of another embodiment of the present invention;

FIG. 14 is a detailed cross sectional view of FIG. 13 showing the check valve in a closed position when the hydrant is on;

FIG. 15 is a detailed cross sectional view of FIG. 13 showing the check valve in an open position when the hydrant is off;

FIG. 16 is a cross sectional view showing a hydrant of another embodiment of the present invention;

FIG. 17 is a detail view of FIG. 16;

FIG. 18 is a detail view of FIG. 17

FIG. 19 is a cross section of another embodiment of the present invention; and

FIG. 20 is a table showing a comparison of various hydrant assemblies and the operation cycle of each.

It should be understood that the drawings are not necessarily to scale, but that relative dimensions nevertheless can be determined thereby. In certain instances, details that are not necessary for an understanding of the invention or that render other details difficult to perceive may have been omitted. It should be understood, of course, that the invention is not necessarily limited to the particular embodiments illustrated herein.

To assist in the understanding of one embodiment of the present invention the following list of components and associated numbering found in the drawings is provided herein:

#	Component
2	Hydrant
4	Head
5	Handle
6	Standpipe
10	Drain port
14	Frost line
18	Venturi
22	Diverter
26	Vacuum breaker
30	Siphon tube
34	Check valve
36	Outlet
37	Venturi vacuum inlet and drain port
38	Hydrant inlet valve
42	Bypass
46	Bypass button
50	Casing cover
54	Piston
56	Bypass valve
57	Control rod
58	Secondary spring operated piston
59	Bottom surface
60	EFR button
64	LED
68	Screen piston
72	Reservoir
76	Check valve piston
80	Vent

DETAILED DESCRIPTION

The venturi **18** and related components used in the hydrants of the prior art is shown in FIGS. **3** and **4** and functions when the hydrant issued in conjunction with a vacuum breaker and a diverter. The diverter is needed to allow the venturi to work properly in light of the flow obstructions associated with the vacuum breaker. A typical on/off cycle for this hydrant (see also FIG. **2**) requires that the user open the hydrant to cause water to exit the diverter **22** and not the vacuum breaker **26**. As the water flows out of the diverter **22**, a vacuum is created that draws water through a siphon tube **30** and check valve **34**, which evacuates the reservoir (not shown). Flowing water through the diverter **22** for about 30 to 45 seconds will generally evacuate the reservoir. Next, as shown in FIG. **2**, the diverter **22** is pulled down to redirect the water out of the vacuum breaker **26**. The vacuum breaker **26** allows the hydrant **2** to be used with an attached hose and/or a spray nozzle as the vacuum breaker **26** will evacuate the head when the hydrant **2** is shut off, thereby making it frost proof. When the water is flowing out of the vacuum breaker **26** the venturi **18** will stop working and the one-way check valve **34** will prevent water from entering the reservoir. Once the hydrant is shut off, the water in the standpipe **6** will drain through a venturi vacuum inlet and drain port **37** that is in fluid communication with the reservoir similar to that disclosed in U.S. Pat. No. 5,246,028 to Vandepas, which is incorporated by reference herein. The check valve **34** is also pressurized when the hydrant is turned off because the shut off valve **38** is located above the check valve **34**.

A venturi assembly used in other hydrants that employ a pressurized reservoir also provides a vacuum only when water flows through a diverter. A typical on/off cycle for a hydrant that uses this venturi configuration is similar to that described above, the exception being that a check valve that prevents water from entering the reservoir is not used. When the diverter is transitioned so water flows through the vacuum breaker, the backpressure created thereby will cause

water to fill and pressurize the reservoir, which prevents water ingress after hydrant shut off. As the reservoir is at least partially filled with water during normal use, the user needs to evacuate the hydrant after shut off by removing any interconnected hose and diverting fluid for about 30 seconds, which will allow the venturi to evacuate the water from the reservoir.

A hydrant of embodiments of the present invention shown in FIGS. **5-11** which may employ a venturi with an about $\frac{1}{8}$ " diameter nozzle. To account for the decrease in mass flow and associated back pressure that affects the functionality of the venturi described above, a bypass **42** is employed. More specifically, the bypass **42** maintains the flow rate out of the hydrant head **4** and allows for water to be expelled from the head **4** at the expected velocity. Fluid bypass is triggered by actuating a button **46** located on the casing cover **50** as shown in FIG. **11**. When the hydrant is turned on the user pushes the bypass button **46** that will in turn move a bypass piston **54** of a bypass valve **56** into the open position as shown in FIG. **9**. This will allow water to bypass the venturi **2** and re-enter the standpipe above the restriction caused by the venturi. The increased flow rate is greater than could be achieved with a venturi alone, even if the diameter of the venturi nozzle was increased.

While the bypass allows the mass flow rate to increase greatly, it also causes the venturi to stop creating a vacuum that is needed to evacuate the reservoir. Before normal use, the bypass piston **54** is closed as shown in FIG. **10**. Similar to the system described in FIG. **16** below, the venturi **18** and associated bypass **42** are associated with a control rod **57** that is associated with the hydrant handle **5**. Opening of the hydrant transitions the control rod **57** upwardly, which pulls the venturi **18** and associated bypass **42** upwardly and opens the hydrant inlet valve **38** to initiate fluid flow. Conversely, transitioning the hydrant handle **5** to a closed position will move the venturi **18** and associated bypass **42** downwardly such that a secondary spring operated piston **58** of the bypass valve **56** well contact a bottom surface **59** of the reservoir. As the secondary spring piston **58** contacts the bottom surface **59**, the bypass valve **54** moves to a closed position as shown in FIG. **10**. Moving the handle **5** to an open position to initiate fluid flow through the hydrant head will separate the secondary spring operated piston **58** from the bottom surface **59** of the reservoir which allows the bypass piston **54** to move to an open position as shown in FIG. **9** when the bypass button **46** is actuated. When the bypass **42** is in the closed position, water is forced to flow through the venturi causing a vacuum to occur, thereby causing the reservoir to be evacuated each time the hydrant is used. After water flows from the vacuum breaker for a predetermined time, the user will actuate the bypass button **46** which opens the bypass valve **56** to divert fluid around the venturi **2**. The secondary spring operated piston **58**, which is designed to account for tolerances making assembly of the hydrant easier. The secondary spring operated piston **58** also makes sure the hydrant will operate properly if there are any rocks or debris present in the hydrant reservoir.

The venturi **18** of this embodiment can be operated in a 7' bury hydrant with a minimum operating pressure of 25 psi. The other major exception is the addition of the aforementioned bypass valve **56** that allows the hydrant to achieve higher flow rates.

In operation with a hose, initially the hose is attached to the backflow preventer **26** or the bypass button is pushed to that the venturi will not operate correctly and the one way check valve **34** will be pressurized in such a way to prevent flow of fluid from the reservoir. After the hydrant is shut off,

the hose is removed from vacuum breaker 26. Next the hydrant 2 is turned on and water flows through the vacuum breaker 26 for about 30 seconds. When there is no hose attached, and the bypass has not been activated, the venturi 18 will create a vacuum that suctions water from the reservoir 72 and making the hydrant frost proof. Thus when the hydrant is later shut off, the check valve piston will move up and force open the one way check valve 37 to allow water in the hydrant to drain into the reservoir. This operation will also reset the bypass valve 56 into the closed position.

Some embodiments of the present invention will also be equipped with an Electronic Freeze Recognition (EFR) device as shown in FIG. 11. The EFR includes a button 60 that allows the user to ascertain if the water has been evacuated from the standpipe 6 properly and if the hydrant is ready for freezing weather. The device uses a circuit board in concert with a dual color LED 64 as shown in FIG. 11 to warn the operator of a potential freezing problem. When the EFR button 60 is pushed and the LED 64 glows red it indicates that the hydrant has not been evacuated properly. This informs the operator that the water in the reservoir is above the frost line, and the hydrant needs to be evacuated by the method described above. A green LED 64 indicates the hydrant has been operated properly and the hydrant is ready for freezing weather.

Flow rates for hydrants of embodiments of the present invention compare favorably with existing sanitary hydrants on the market, see FIG. 12. The prior art models are compared with hydrants that use a vacuum breaker and hydrants that use a double check backflow preventer. The venturi and related bypass system will meet ASSE 1057 specifications.

Another embodiment of the present invention is shown in FIGS. 13-15 that does not employ a bypass. Variations of this embodiment employ an about 0.147 to an about 0.160 diameter nozzle, which allows for a flow rate of 3 gallons per minute at 25 psi and evacuation of the reservoir at 20 psi. As this configuration meets the desired mass flow characteristics, a bypass is not required to obtain the mass flow rate, and therefore this hydrant can be produced at a lower cost. This embodiment also employs a dual-use check valve. The check valve is closed by a spring when the hydrant is turned on as shown in FIG. 14 to prevent water from filling the reservoir. Again, when water is flowing through the double check backflow preventer a suction can still be produced to pull water from the reservoir through this check valve. When the hydrant is turned off, a screen piston 68 moves up when it contacts the bottom surface 59 of the reservoir which forces the check valve 34 into the open position as shown in FIG. 15. This allows the water in the hydrant to drain into the reservoir, thereby making the hydrant freeze resistant. Other embodiments of the present invention employ a venturi to evacuate a reservoir, but do not need a diverter to operate correctly. More specifically, a venturi is provided that will evacuate a reservoir through a double check backflow preventer.

FIGS. 16-18 show a hydrant of another embodiment of the present invention that is simpler and more user friendly than sanitary hydrants currently in use. This hydrant is limited to a 5' bury depth and a minimum working pressure of about 40 psi, which maximizes the venturi flow rate potential, while still being able to evacuate the reservoir as water flows through a double check. A one-way check valve 34 is provided that is forced open when the hydrant is shut off as shown in FIG. 17.

In operation, this venturi system operates similar to those described above with respect to FIGS. 5-11. More specifi-

cally, the venturi is interconnected to a movable control rod 57 that is located within the standpipe 6. The handle 5 of the hydrant is thus ultimately interconnected to the venturi 18 and by way of the control rod 57. To turn on the hydrant, the user moves the handle 5 to an open position, which pulls the control rod 57 upwardly and opens the inlet valve 38 such that water can enter the venturi 18. Pulling the venturi upward also removes the check valve 34 upwardly such that the screen piston 68 moves away from the bottom surface 59 of the hydrant 2. To turn the hydrant off, the handle 5 is moved to a closed position which moves the control rod 57 downwardly to move the venturi 18 downwardly to close the inlet valve 38. Moving the venturi downwardly also transitions the screen piston 68 which opens the check valve 34. To allow for evacuation reservoir a vent 80 may be provided on an upper surface of the hydrant.

Generally, this hydrant functions when a hose is attached to the backflow preventer. When the hose is attached, the venturi will not operate correctly and the pressure acting on the one way check valve 34 will prevent water ingress into the reservoir 72. After the hydrant is shut off, the hose is removed from vacuum breaker, the hydrant must be turned on so that the water can flow through the double check vacuum preventer for about 15 seconds. That is, when there is no hose attached, the venturi will create a vacuum sufficient enough to suction water from the reservoir 72, and making the hydrant frost proof. When the hydrant is later shut off, the check valve piston 26 will move up and force the one way check valve to an open position which allows the water in the hydrant to drain into the reservoir 72.

FIG. 19 shows yet another hydrant of embodiments of the present invention that is designed specifically for mild climate use (under 2' bury) and roof hydrants. The outer pipe of the roof hydrant is a smaller 1½ diameter PVC, instead of the 3" used in some of the embodiments described above. This hydrant uses a venturi without a check valve in concert with a pressurized reservoir, a diverter is not used. The operation is the same as described above with respect to hydrant with a pressurized reservoir, with the evacuation of the reservoir being completed after the user detaches the hose.

FIG. 20 is a table comparing the embodiments of the present invention, which employ an improved venturi of that employ a bypass system, with hydrants of the prior art manufactured by the Assignee of the instant application. The embodiment shown in FIG. 7, for example, provides an increased flow rate, has an increased bury depth, and can operate at lower fluid inlet pressures. The evacuation time is discussed over the prior art.

While various embodiments of the present invention have been described in detail, it is apparent that modifications and alterations of those embodiments will occur to those skilled in the art. However, it is to be expressly understood that such modifications and alterations are within the scope and spirit of the present invention, as set forth in the following claims. Further, the invention(s) described herein is capable of other embodiments and of being practiced or of being carried out in various ways. In addition, it is to be understood that the phraseology and terminology used herein is for the purpose of description and should not be regarded as limiting. The use of "including," "comprising," or "having" and variations thereof herein is meant to encompass the items listed thereafter and equivalents thereof as well as additional items. For example, aspects of inventions disclosed in U.S. Pat. Nos. 5,632,303, 5,590,679, 7,100,637, 5,813,428, and 20060196561, all of which are incorporated herein by this reference, which generally concern backflow prevention,

11

may be incorporated into embodiments of the present invention. Aspects of inventions disclosed in U.S. Pat. Nos. 5,701,925 and 5,246,028, all of which are incorporated herein by this reference, which generally concern sanitary hydrants, may be incorporated into embodiments of the present invention. Aspects of inventions disclosed in U.S. Pat. Nos. 6,532,986, 6,805,154, 6,135,359, 6,769,446, 6,830,063, RE39235, 6,206,039, 6,883,534, 6,857,442 and 6,142,172, all of which are incorporated herein by this reference, which generally concern freeze-proof hydrants, may be incorporated into embodiments of the present invention. Aspects of inventions disclosed in U.S. Patent and Published Patent Application Nos. D521113, D470915, 7,234,732, 7,059,937, 6,679,473, 6,431,204, 7,111,875, D482431, 6,631,623, 6,948,518, 6,948,509, 20070044840, 20070044838, 20070039649, 20060254647 and 20060108804, all of which are incorporated herein by this reference, which generally concern general hydrant technology, may be incorporated into embodiments of the present invention.

What is claimed is:

1. A sanitary hydrant, comprising:
 - a pipe having a first end and a second end;
 - a head interconnected to the first end of the pipe;
 - a fluid reservoir associated with the second end of the pipe
 - a venturi positioned within the reservoir and interconnected to the second end of the pipe, the venturi comprised of a first end, which is interconnected to the pipe, and a second end associated with a fluid inlet valve with a throat between the first end and the second end of the venturi;
 - a bypass tube having a first end interconnected to a location adjacent to the first end of the venturi and a second end interconnected to a bypass valve, the bypass valve also associated with the second end of the venturi;
 - wherein when the bypass valve is opened, fluid flows from the inlet valve, through the bypass tube, through the pipe, and out the head; and
 - wherein when the bypass valve is closed, fluid flows through the venturi.
2. The hydrant of claim 1, further comprising a check valve associated with the venturi that selectively allows access to the internal volume of the reservoir.
3. The hydrant of claim 1, wherein further comprising a freeze recognition button that allows the user to ascertain if the water has been evacuated from the pipe after flow of fluid from the hydrant is ceased.
4. The hydrant of claim 3, wherein the freeze recognition button is associated with a visual indicator.
5. The hydrant of claim 1, wherein a double check valve is associated with the head of the hydrant.
6. The hydrant of claim 5, wherein the double check valve is comprised of: a valve body with threads that are adapted to receive a hose, the valve body also having an inlet volume and an outlet volume separated by an internally-disposed wall, a lower surface of the wall defining a valve seat, the valve body further including a vent that provides a flow path between the outside of the valve body and the inlet volume;
 - a seal positioned within the valve body in a volume located adjacent to the inlet volume, the seal adapted to selectively block the vent;
 - a valve cap interconnected to the valve body that is positioned within the volume that maintains the seal

12

- against the valve body, the valve cap having threads for interconnection to a fluid outlet of the head;
 - an inlet check valve comprising: an inlet check spring positioned within the inlet volume, wherein the spring contacts an upper surface of the wall, an inlet check body positioned within the inlet check spring, an inlet check seal interconnected to the inlet check body that is adapted to selectively engage the seal, thereby opening and closing an aperture of the seal to control fluid flow from the valve cap into the inlet volume;
 - a drain spring positioned within the outlet volume that contacts the seat and a plunger that is adapted to engage a hose;
 - an outlet check valve comprising: an outlet check body positioned within the drain spring, an outlet check seal interconnected to the outlet check body that is adapted to selectively engage the seat to either open a flow path between the inlet volume and outlet volume, or isolate the outlet volume from the inlet volume, thereby preventing fluid from flowing from an interconnected hose into the fluid outlet of the head; and
 - an outlet check spring positioned about the outlet check body that contacts a portion of the outlet check body and a hub of the plunger.
7. A method of evacuating a sanitary hydrant, comprising:
 - providing a pipe having a first end and a second end;
 - providing a head for delivering fluid interconnected to the first end of the pipe;
 - providing a fluid reservoir associated with the second end of the pipe;
 - providing a venturi positioned within the reservoir and interconnected to the second end of the pipe, the venturi comprised of a first end, which is interconnected to the pipe, and a second end associated with a fluid inlet valve with a throat between the first end and the second end of the venturi;
 - providing a bypass tube having a first end interconnected to a location adjacent to the first end of the venturi and a second end interconnected to a bypass valve, the bypass valve also associated with the second end of the venturi, wherein when the bypass valve is opened, fluid flows from the inlet valve, through the bypass tube, through the pipe, and out the head; and wherein when the bypass valve is closed, fluid flows through the venturi;
 - initiating fluid flow through the head by actuating a handle associated therewith;
 - actuating a bypass button that opens the bypass valve such that fluid is precluded from entering the venturi;
 - actuating the bypass button to close the bypass valve;
 - flowing fluid through the venturi;
 - evacuating the reservoir;
 - ceasing fluid flow through the hydrant; and
 - draining fluid into the reservoir.
 8. The method of claim 7, further comprising interconnecting a hose to the head with a backflow preventer therebetween.
 9. The method of claim 7, further comprising a check valve associated with the venturi that selectively allows access to the internal volume of the reservoir.
 10. The method of claim 7, further comprising actuating a freeze recognition button; and ascertaining if the water has been evacuated from the pipe after flow of fluid from the hydrant is ceased.