



US00RE47752E

(19) **United States**
(12) **Reissued Patent**
Hughes

(10) **Patent Number: US RE47,752 E**
(45) **Date of Reissued Patent: *Dec. 3, 2019**

(54) **CLOSET FLANGE SYSTEM FOR EXISTING INSTALLATION**

- (71) Applicant: **OATEY CO.**, Cleveland, OH (US)
- (72) Inventor: **Alan Hughes**, Wayne, NJ (US)
- (73) Assignee: **OATEY CO.**, Cleveland, OH (US)
- (*) Notice: This patent is subject to a terminal disclaimer.
- (21) Appl. No.: **14/510,620**
- (22) Filed: **Oct. 9, 2014**

Related U.S. Patent Documents

Reissue of:

- (64) Patent No.: **8,281,421**
- Issued: **Oct. 9, 2012**
- Appl. No.: **13/325,343**
- Filed: **Dec. 14, 2011**

U.S. Applications:

- (63) Continuation of application No. 12/442,127, filed as application No. PCT/US2007/020392 on Sep. 20, 2007, now Pat. No. 8,099,801.
- (60) Provisional application No. 60/845,851, filed on Sep. 20, 2006.
- (51) **Int. Cl.**
E03D 11/16 (2006.01)
- (52) **U.S. Cl.**
CPC *E03D 11/16* (2013.01); *Y10T 29/49826* (2015.01)
- (58) **Field of Classification Search**
CPC E03D 11/16; E03D 11/17
USPC 4/252.1, 252.4, 252.5, 252.6; 285/56, 58
See application file for complete search history.

(56) **References Cited**

U.S. PATENT DOCUMENTS

D29,291 S	8/1898	Rice	
D34,101 S	2/1901	Griffiths	
812,543 A	2/1906	Buchanan, Jr.	
858,865 A	7/1907	Forster et al.	
870,085 A	11/1907	Cosgrove	
1,061,632 A *	5/1913	Podolsky	285/58
1,333,368 A *	3/1920	Auer	E03D 11/16 285/363
1,648,665 A	11/1927	Swanson et al.	
2,479,837 A *	8/1949	Hollaender	285/60
2,673,985 A	4/1954	Gay	

(Continued)

OTHER PUBLICATIONS

Flier for J-tec Products Company, "Closet Flange Extension", undated, 1 page.

(Continued)

Primary Examiner — Russell D Stormer

(57) **ABSTRACT**

A system is provided herein which includes a closet flange insert and at least one spacer to be positioned between the closet flange insert and an installed closet flange. The closet flange insert includes a toilet connecting flange which extends radially outwardly from a through pipe. The through pipe is sized to be inserted into a pipe section of a closet flange. Each spacer includes spaced apart first and second faces, and spaced apart inner and outer edges extending between the first and second faces. The inner edge defines an opening extending through the body, the opening sized to permit passage therethrough of the through pipe of the closet flange insert but not the toilet connecting flange of the closet flange insert. With the subject invention, a system is provided which allows the closet flange insert to be mounted atop an installed closet flange flush with surrounding finished flooring.

7 Claims, 4 Drawing Sheets

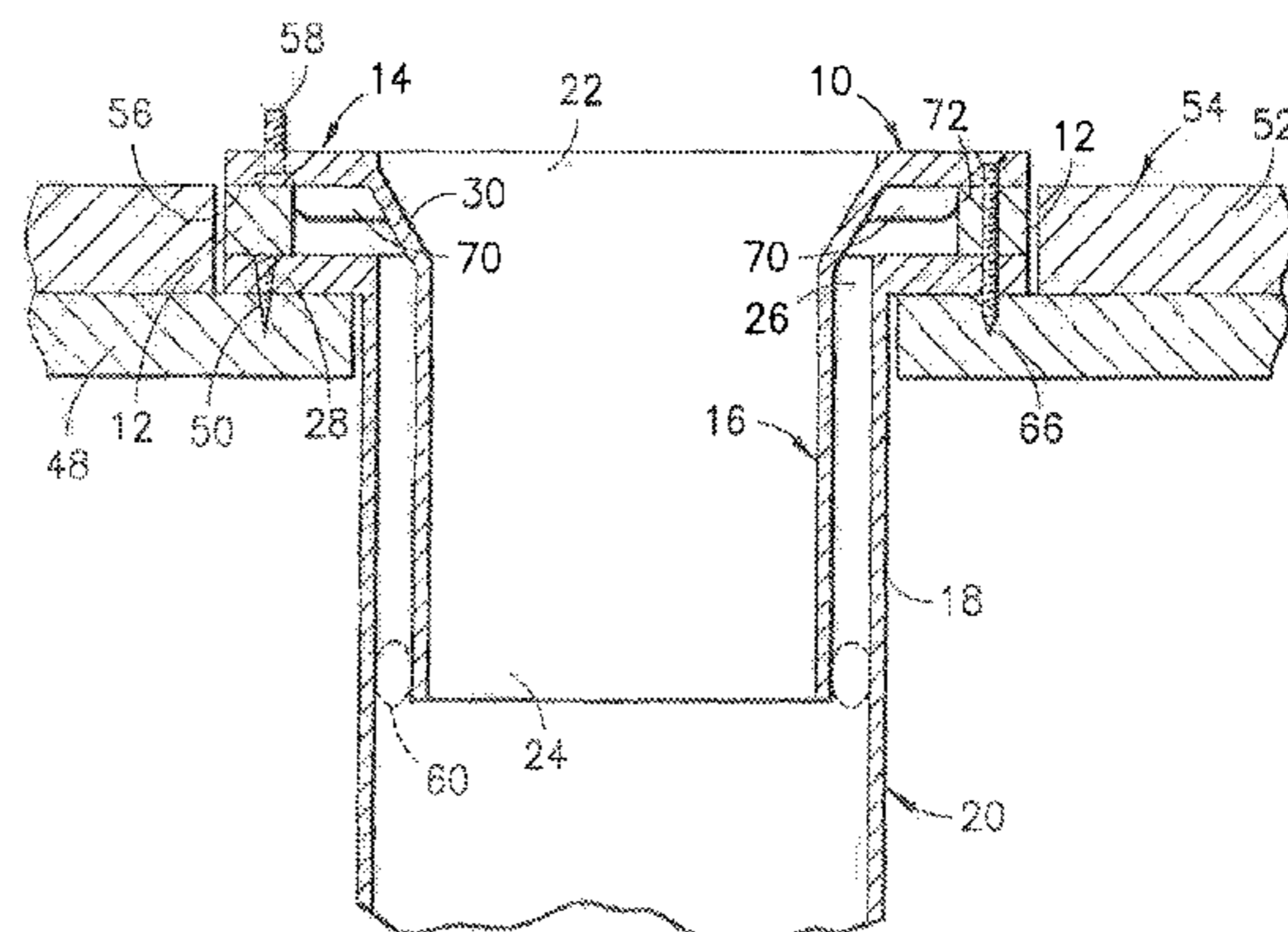
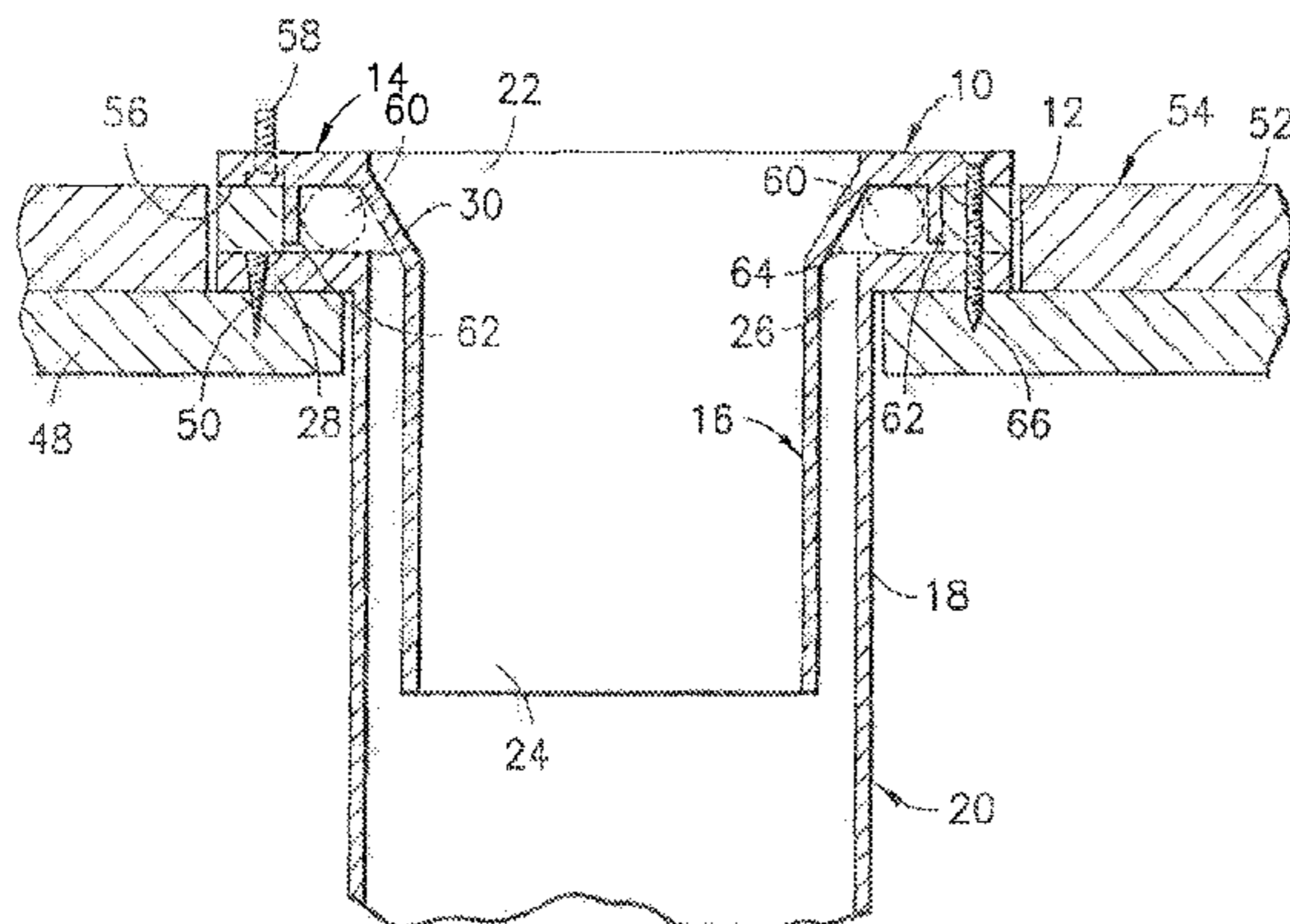

(56)

References Cited

U.S. PATENT DOCUMENTS

2,750,216 A * 6/1956 Thies 4/252.6
 2,908,513 A 10/1959 Karlinski
 3,012,252 A * 12/1961 Roy Gaddy 4/252.5
 3,311,391 A * 3/1967 Harrell 285/58
 3,501,172 A 3/1970 Pickard
 3,846,851 A 11/1974 Pepper
 3,896,510 A 7/1975 O'Connell
 3,967,326 A 7/1976 Tammen
 4,090,267 A 5/1978 Cuschera
 4,207,630 A 6/1980 Bressler
 4,233,697 A 11/1980 Cornwall
 4,384,910 A 5/1983 Prodyrna
 4,406,480 A 9/1983 Izzzi
 4,482,161 A 11/1984 Izzzi, Sr.
 4,502,166 A 3/1985 Brown, Sr.
 4,515,398 A 5/1985 Machon, Sr.
 4,562,602 A 1/1986 Cuschera
 4,827,539 A 5/1989 Kiziah
 4,984,308 A 1/1991 Handal
 5,018,224 A 5/1991 Hodges 4/252.6
 5,115,554 A 5/1992 Fell, Sr.
 5,185,890 A 2/1993 Dismore et al.
 D334,051 S 3/1993 Fell, Sr.
 5,190,320 A 3/1993 Hodges
 5,232,250 A 8/1993 Bonacci
 5,297,817 A 3/1994 Hodges
 5,377,361 A 1/1995 Piskula
 5,421,036 A 6/1995 Stevens et al.
 5,432,957 A 7/1995 Fernie et al.
 5,492,372 A 2/1996 Dranberg
 5,937,450 A 8/1999 Jones
 5,996,134 A 12/1999 Senninger
 6,065,160 A 5/2000 Winn
 6,070,910 A 6/2000 Hodges
 6,085,362 A 7/2000 Huber
 6,128,947 A 10/2000 Anderson, Sr.

6,223,356 B1 5/2001 Corbin
 6,332,632 B1 12/2001 Hodges
 6,381,775 B1 5/2002 Sondrup
 6,443,495 B1 9/2002 Harmeling
 6,519,784 B2 2/2003 Carwile
 6,581,214 B1 6/2003 Love et al.
 6,598,241 B1 7/2003 Williams
 6,691,331 B2 * 2/2004 Gallacher et al. 4/252.5
 6,745,408 B2 6/2004 Spells, Sr.
 6,751,812 B2 6/2004 Malloy
 7,069,603 B2 7/2006 Flushing
 D574,931 S 8/2008 Hughes
 7,805,777 B2 10/2010 Hughes
 8,099,801 B2 1/2012 Hughes
 2001/0045710 A1 * 11/2001 Nguyen et al. 277/604
 2004/0034907 A1 2/2004 Malloy
 2005/0050623 A1 3/2005 Greene
 2005/0060795 A1 3/2005 Long et al.
 2005/0278841 A1 12/2005 Coronado et al.
 2006/0213003 A1 9/2006 Hughes
 2008/0148469 A1 6/2008 Dipzinski et al.
 2010/0123307 A1 5/2010 Coronado

OTHER PUBLICATIONS

Web page, <http://jtecprod.com/products2.html>, untitled document, dated Mar. 12, 2005, 1 page.
 Quik-Fix, "closet ring extenders, flange support kit, metal ring replacement flange, Quik Fix, Span-A-B . . ." <http://www.quickfixplumbingproducts.com/>, dated Mar. 23, 2005, 3 pages.
 Quik-Fix, "closet flange extender brochure", <http://www.quickfixplumbingproducts.com/extbroch.htm>, dated Mar. 23, 2005, 1 page.
 Web page, <http://www.bluechipdistributor.com/catalog/i203.html>, "New! Sioux Chief Stainless Steel Push-Tile Gasketed Toilet Flange", Mar. 23, 2005, 1 page.
 Web page, <http://www.wantasub.com/bayflange.html>, "Toilet Flange", Mar. 23, 2005, 1 page.

* cited by examiner

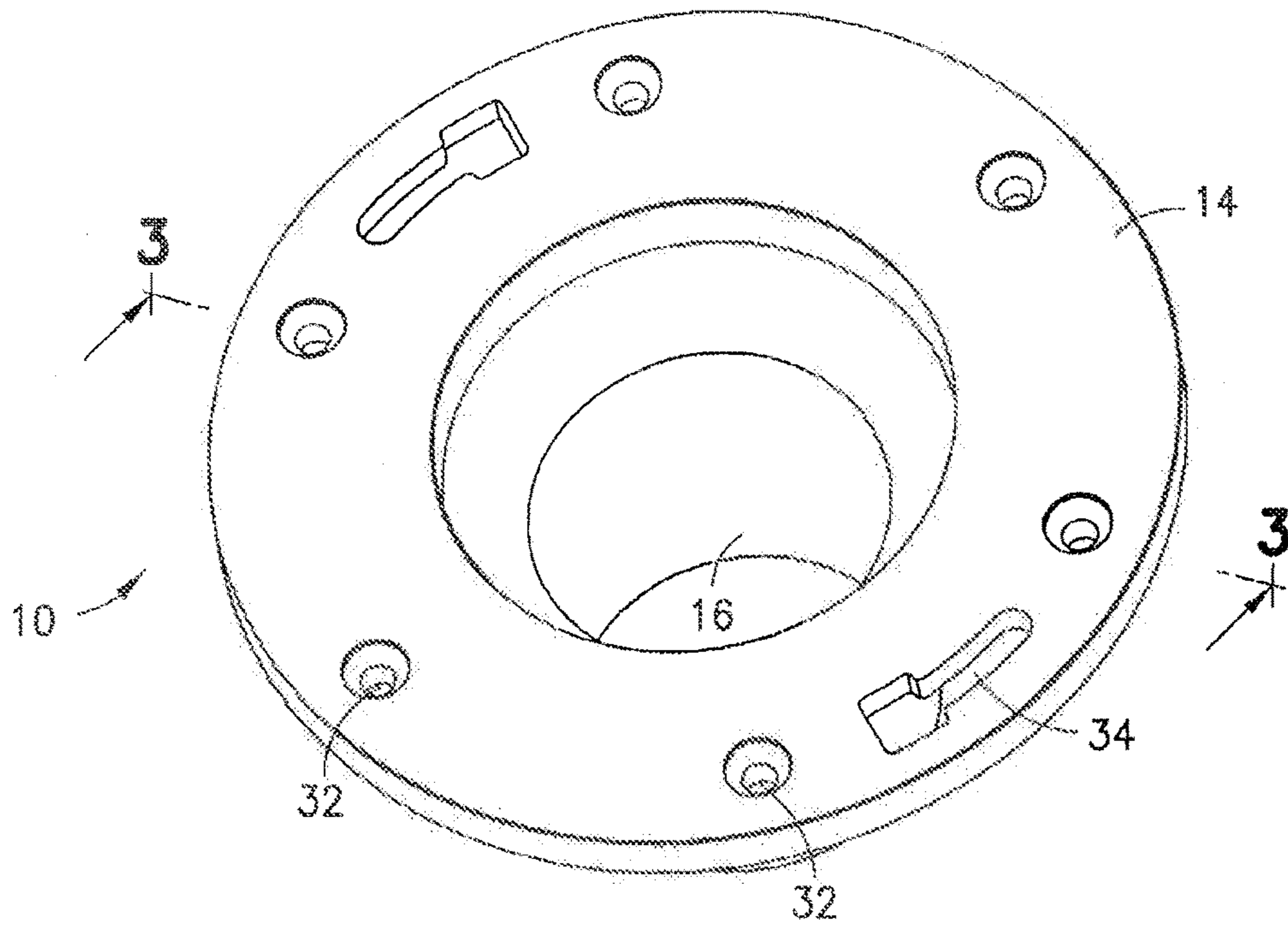

FIG. 1

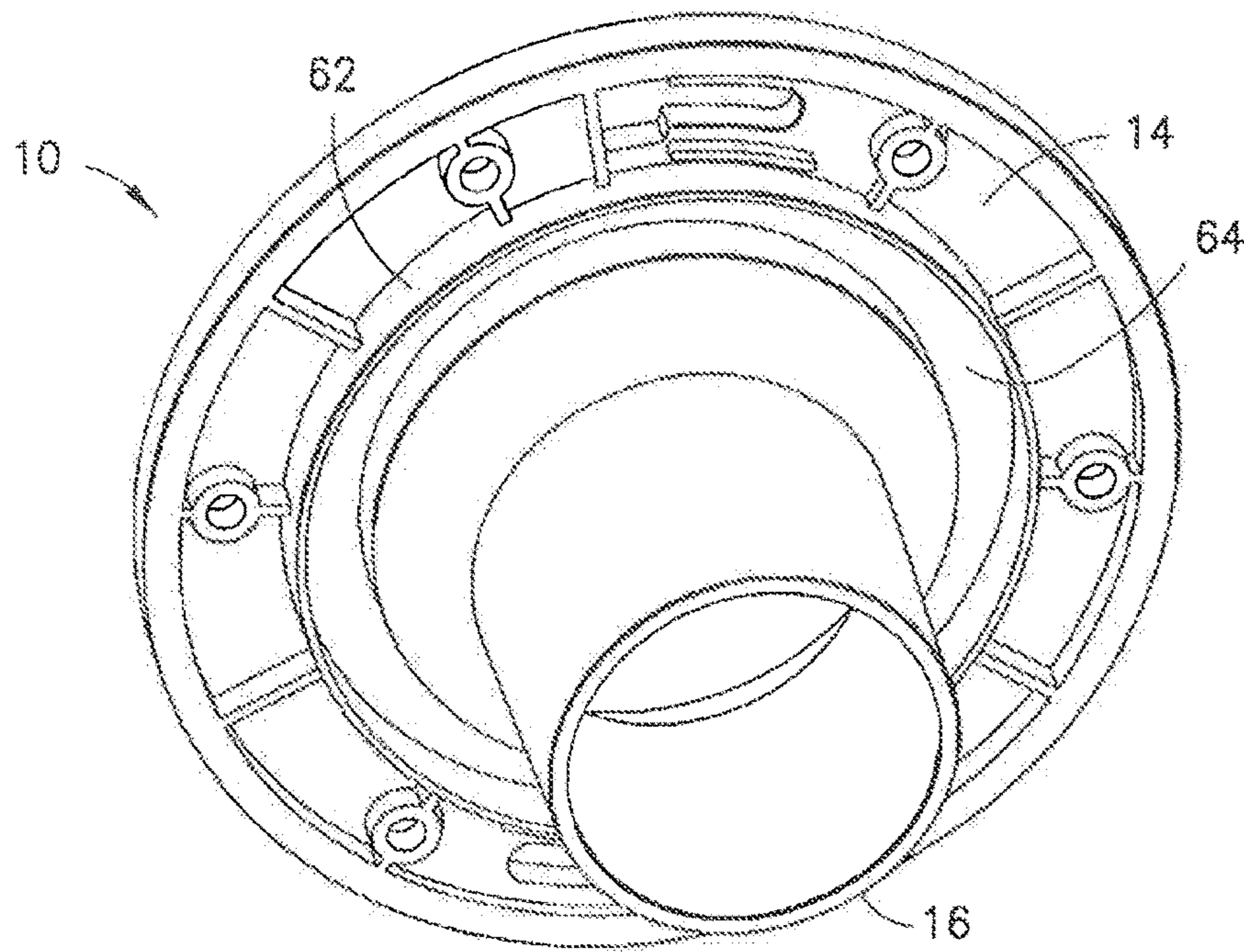

FIG. 2

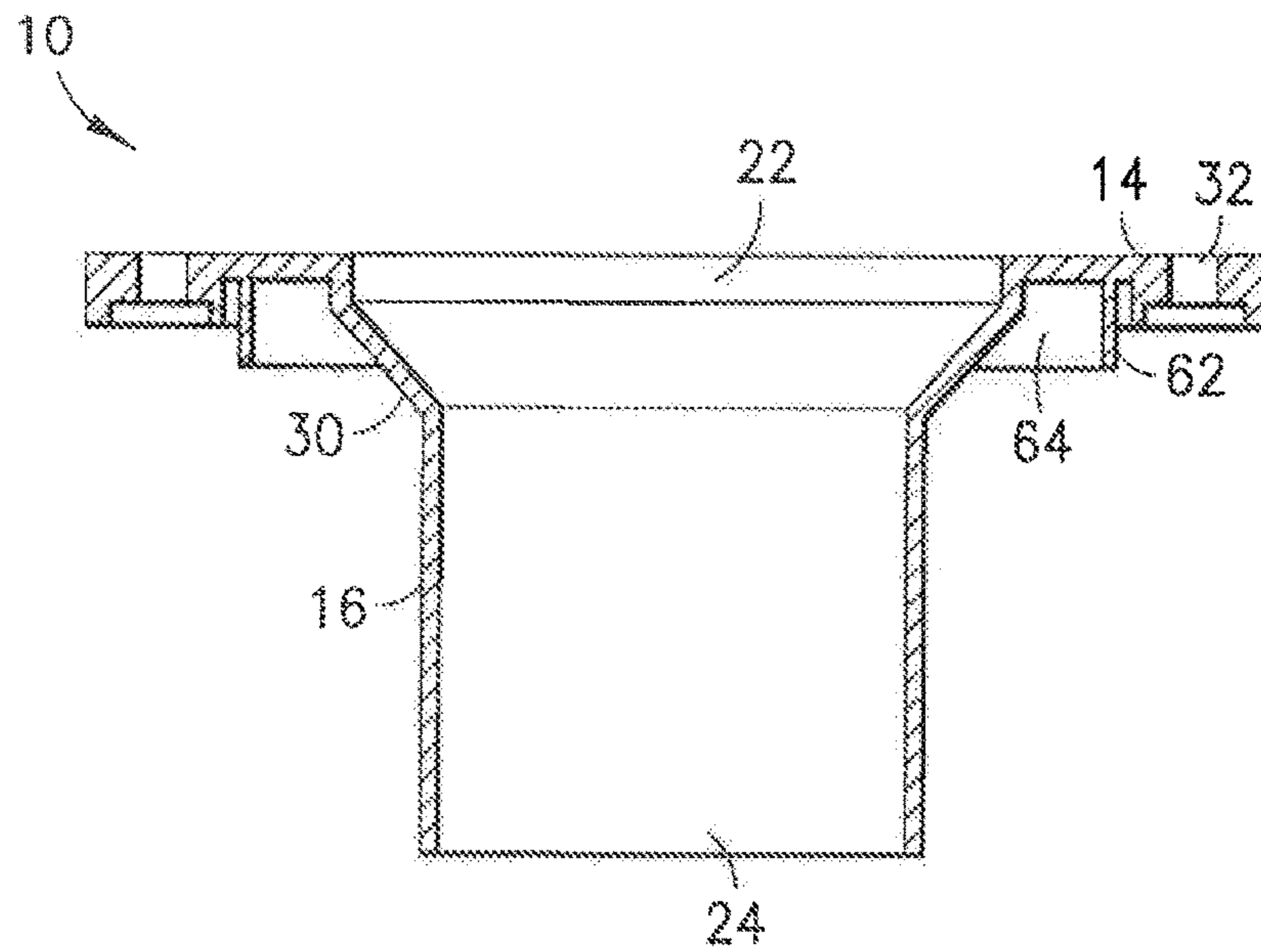

FIG. 3

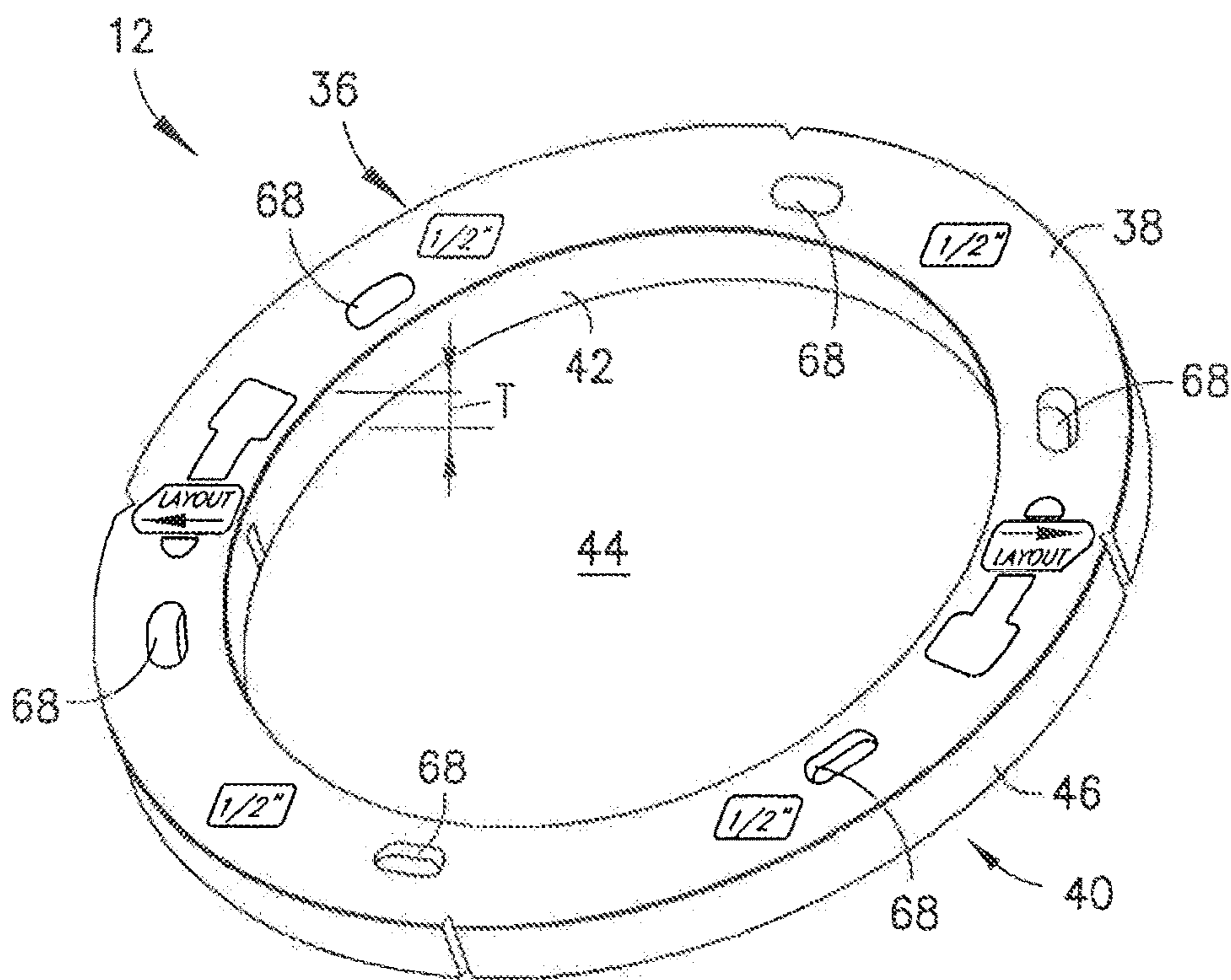

FIG. 4

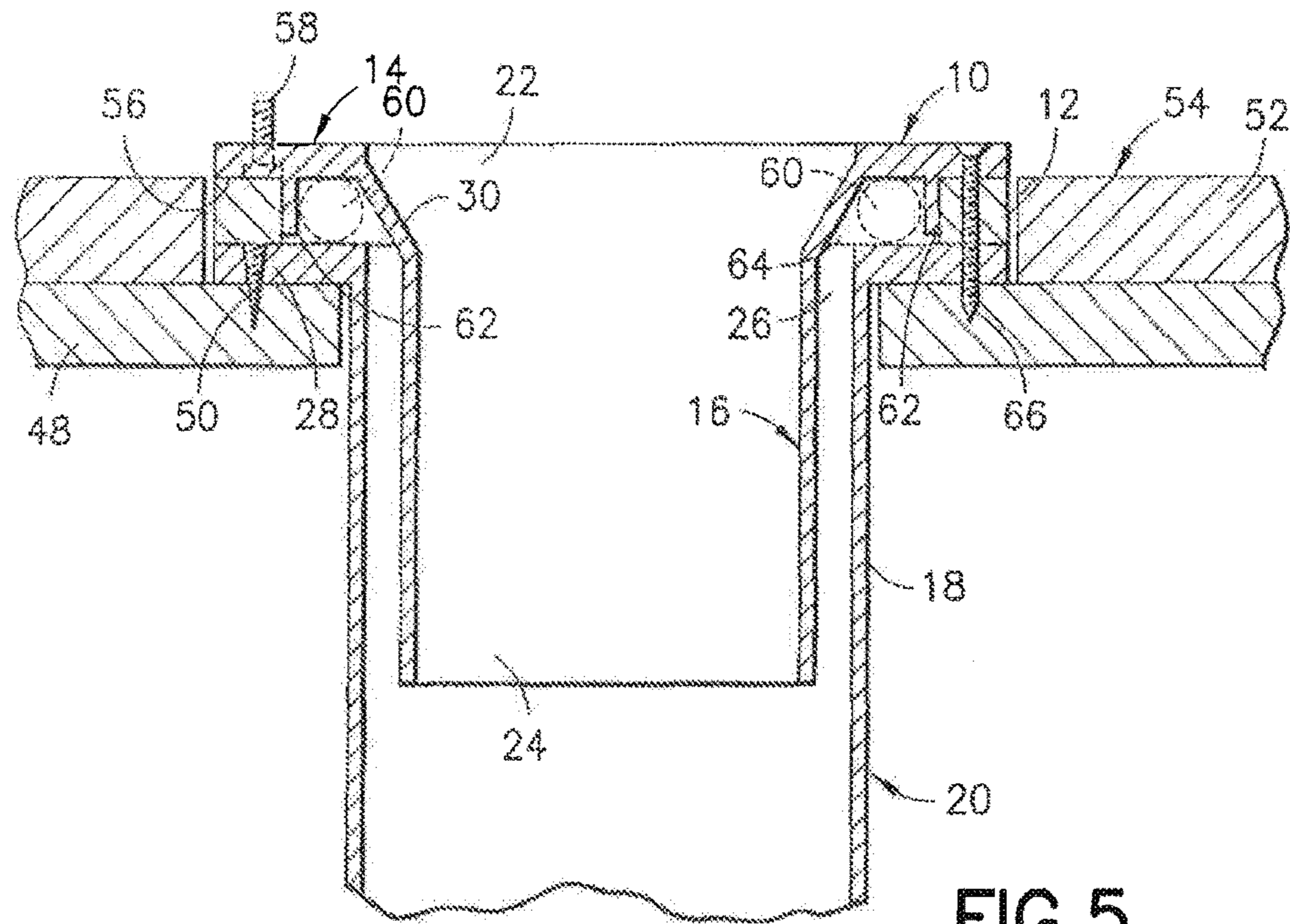

FIG. 5

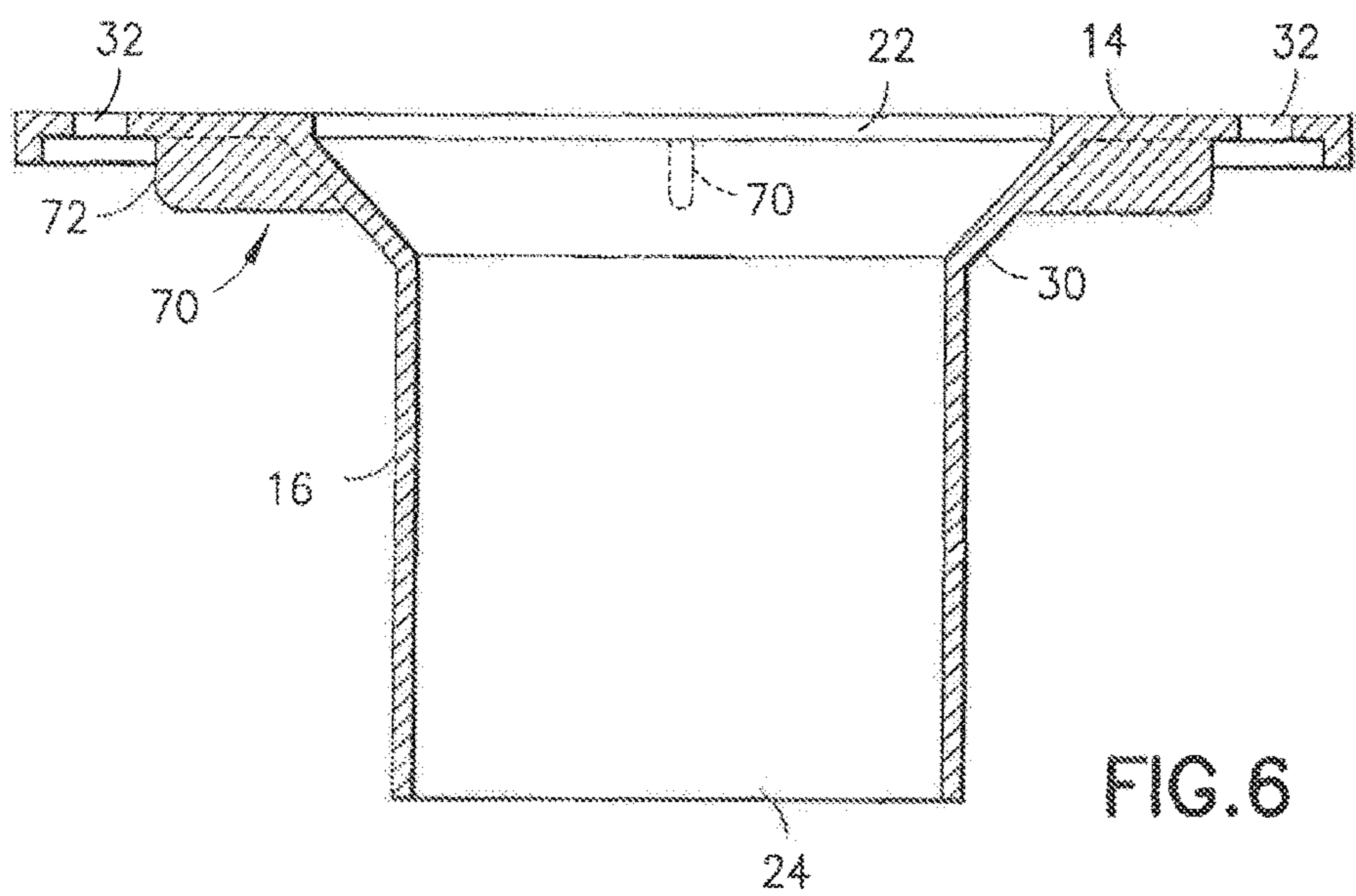

FIG. 6

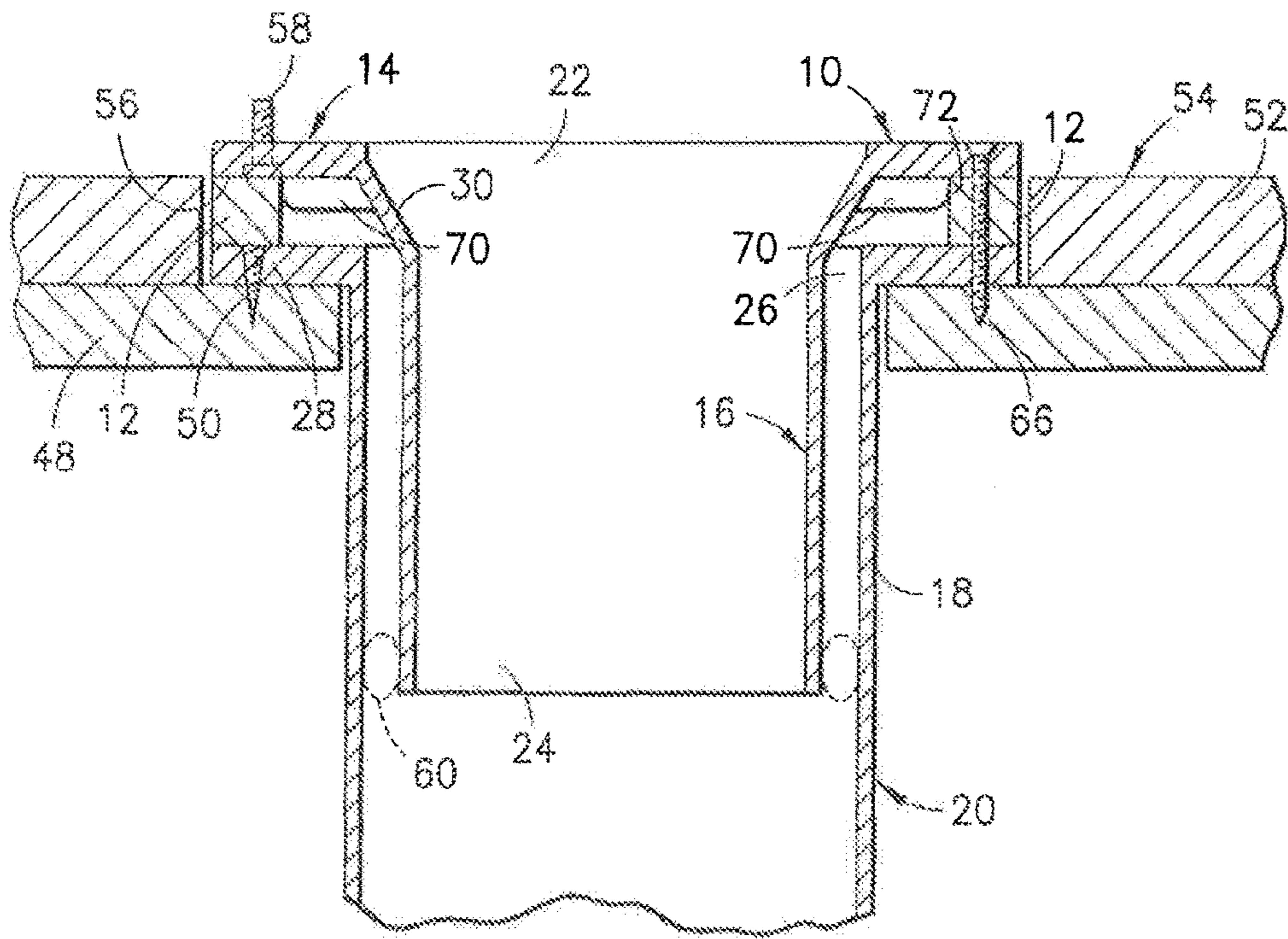

FIG. 7

CLOSET FLANGE SYSTEM FOR EXISTING INSTALLATION

Matter enclosed in heavy brackets [] appears in the original patent but forms no part of this reissue specification; matter printed in italics indicates the additions made by reissue; a claim printed with strikethrough indicates that the claim was canceled, disclaimed, or held invalid by a prior post-patent action or proceeding.

CROSS-REFERENCES TO RELATED APPLICATIONS

This application is a continuation of U.S. application Ser. No. 12/442,127, filed Mar. 20, 2009, now U.S. Pat. No. 8,099,801, which is a National Stage Application under 35 U.S.C. §371 of PCT Application No. PCT/US2007/020392, filed Sep. 20, 2007, which claims priority of U.S. Provisional Application No. 60/845,851, filed Sep. 20, 2006, the entire contents of which are hereby incorporated by reference.

BACKGROUND OF THE INVENTION

With new building construction or renovation, a closet flange is typically installed prior to installation of finished flooring. To do so, a hole is made through the sub-flooring at a desired location for a toilet. The hole is sized to accommodate a closet flange. There are, then, several options in the prior art to install a closet flange through the hole in the sub-flooring. In one option, a closet flange is directly fastened to the sub-flooring, and a finished flooring is installed about the closet flange. With the closet flange fixed to the sub-flooring, however, the finished flooring extends above the closet flange, thus not permitting a direct connection between a toilet and the closet flange. To allow for a proper sealed connection, closet flange extenders have been developed in the prior art to increase the height of the closet flange to that of the finished flooring, such as described in U.S. Pat. No. 4,384,910 to Prodyna, and U.S. Pat. No. 5,018,224 to Hodges. As can be appreciated by those skilled in the art, the closet flange extenders are in contact with any fluid flow from the toilet bowl and provide undesired additional leakage points.

To avoid closet flange extenders, closet flanges have been installed with spacers to elevate the closet flanges above the sub-flooring. Typically, materials available at a building site have been used as the spacers to elevate a closet flange. For example, pieces of copper tubing or wood have been wedged between a closet flange and a sub-flooring to elevate the closet flange. Ideally, the spacers allow finished flooring to be installed flush below the closet flange, thereby allowing a toilet to rest on the finished flooring and be directly connected to the closet flange without any closet flange extenders. However, the scrap material spacers often either do not provide sufficient elevation to accommodate the thickness of the finished flooring, thus not permitting a finished flooring to fit between the closet flange and the sub-flooring, or provide an elevation greater than the thickness of the finished flooring, thereby elevating the closet flange more than desired (the toilet may not rest flush on the finished flooring). In either scenario, undesired adjustment of the closet flange height is required.

The problem of coordinating a finished closet flange height and finished flooring has been recognized in the prior art and several solutions have been proposed. For example,

U.S. Pat. No. 6,065,160 to Winn proposes a threaded closet flange which may have its height adjusted by rotation. U.S. Pat. No. 6,751,812 to Malloy proposes a closet flange having a thickened flange portion which coincides with the thickness of a finished floor. The Malloy closet flange is a unitary piece. U.S. Pat. No. 6,443,495 to Harmeling proposes a closet flange having elevation structures located thereabout to provide spacing between the sub-flooring and the closet flange. As with the Malloy closet flange, the Harmeling closet flange is also a unitary structure. U.S. Pat. No. 5,996,134 to Senninger proposes the use of a spacer equivalent to the height of a poured concrete sub-flooring to raise the closet flange above the sub-flooring.

U.S. Pat. No. 6,581,214 to Love et al. discloses a spacer and shim assembly for raising a closet flange. Stackable spacers of equal thickness are provided. The spacers are stacked to achieve a required thickness and are provided with detents to prevent rotation therebetween. Once stacked, the spacers have tabs which are fastened to a sub-flooring, and a closet flange is fixed to the spacers, not to the sub-flooring.

U.S. patent application Ser. No. 11/269,022, filed Nov. 8, 2005 and PCT International Application No. PCT/US2006/10669, filed Mar. 23, 2006, disclose closet flange spacers for supporting a closet flange above a sub-flooring. The disclosed spacers are well-suited for new installations, where a closet flange has yet to be installed. However, in existing installations where closet flanges are already installed, such as in renovations, the closet flange would have to be detached from the sub-flooring and a closet flange re-installed to be used with the disclosed closet flange spacers. It is desired to provide a toilet connection flush with a finished flooring to avoid not only prior art closet flange extenders, but also disassembly of an installed closet flange.

SUMMARY OF THE INVENTION

A system is provided herein which includes a closet flange insert and at least one spacer to be positioned between the closet flange insert and an installed closet flange. The closet flange insert includes a toilet connecting flange which extends radially outwardly from a through pipe. The through pipe is sized to be inserted into a pipe section of a closet flange. Each spacer includes spaced apart first and second faces, and spaced apart inner and outer edges extending between the first and second faces. The inner edge defines an opening extending through the body, the opening sized to permit passage therethrough of the through pipe of the closet flange insert but not the toilet connecting flange of the closet flange insert. Advantageously, with the subject invention, a system is provided which allows the closet flange insert to be mounted atop an installed closet flange, with one or more spacers therebetween, and with the closet flange insert being flush with surrounding finished flooring.

BRIEF DESCRIPTION OF THE DRAWINGS

FIGS. 1 and 2 are perspective views of a closet flange insert of the subject invention;

FIG. 3 is a cross-sectional view of a closet flange insert of the subject invention taken along line 3-3 of FIG. 1;

FIG. 4 is a perspective view of a spacer usable with the subject invention;

FIG. 5 is a schematic cross-section of an installed closet flange spacer system in accordance with the subject invention;

3

FIG. 6 is a perspective view of an alternate configuration of a closet flange insert of the subject invention; and,

FIG. 7 is a schematic cross-section of an installed closet flange spacer system utilizing the closet flange insert shown in FIG. 6.

DETAILED DESCRIPTION OF THE INVENTION

A system is provided herein which includes a closet flange insert **10** and at least one spacer **12**. The spacer(s) **12** are formed in accordance with the disclosure of U.S. patent application Ser. No. 11/269,022, published as U.S. Published Patent Application No. 2006/0213003 A1, and PCT International Application No. PCT/US2006/10669, published as PCT Published Patent Application No. WO 2006/104861. The disclosures of these references are incorporated by reference herein.

The closet flange insert **10** includes an annular flange **14** extending from a through pipe **16**. The through pipe **16** is formed with an outer diameter sized to fit within, and telescope into, a pipe section **18** of a closet flange **20** (FIG. 5). Standard closet flanges typically come in 3 inch or 4 inch diameters. The subject invention may be sized to these standard sizes or to other sizes. The through pipe **16** extends between an inlet opening **22**, formed in the flange **14** and at least partially circumscribed thereby, and an outlet opening **24**. The inlet opening **22** is preferably sized to generally the diameter of an inlet opening **26** of the closet flange **20**. Likewise, the annular flange **14** is preferably sized generally the same as an annular flange **28** of the closet flange **20** so as to act as a toilet connecting flange. Preferably, the annular flange **14** is configured to at least partially overlie the annular flange **28** of the closet flange **20** with the closet flange insert **10** in use. In this manner, the closet flange insert **10**, particularly at the annular flange **14**, may be connected to a toilet in the same manner as the closet flange **20**. It is desired to have the annular flange **14** sized to not pass through the inlet opening **26**.

With reference to FIG. 5, the outlet opening **24** is sized to fit within the pipe section **18** of the closet flange **20** and thus, has a smaller diameter than the inlet opening **22**. To facilitate the change in diameter, a transition **30**, which may be a tapered or flared section of the closet flange insert **10**, such as located along the length of the through pipe **16**, may be provided.

One or more fastener holes **32** may be formed in the annular flange **14**. The fastener holes **32** are circumferentially spaced apart. The fastener holes **32** may be elongated slots to allow for radial adjustment of the closet flange insert **10** relative to any fastener(s) passing therethrough. The fastener holes **32** are sized to accommodate typical fastener diameters, e.g., typical screw diameters. In addition, one or more slots **34** may be provided in the flange **14** shaped to accommodate closet flange bolts.

With reference to FIG. 4, one or more of the spacers **12** may be utilized. Each of the spacers **12** includes a body **36**, which is preferably disc-shaped. The body **36** includes opposed first and second faces **38** and **40**, which are both preferably flat. In addition, the body **36** includes an inner edge **42**, defining an opening **44** through the body **36**, and an outer edge **46**. The opening **44** is sized to permit passage therethrough of the through pipe **16** of the closet flange insert **10** but not the flange **14**. Preferably, the body **36** has an annular shape with the inner and/or outer edges **42**, **46** being circular. The body **36** may be formed with a generally constant thickness **T** between the first and second faces **38**

4

and **40**. The thickness **T** may be generally 0.125 inches, 0.25 inches, 0.5 inches, or 0.75 inches.

With reference to FIG. 5, an installed closet flange spacer system prepared in accordance with the subject invention is shown. The system is used in conjunction with the closet flange **20** having been previously installed. Specifically, the closet flange **20** is fastened to sub-flooring **48** with one or more fasteners **50**. With the installation of new finished flooring **52**, the top surface **54** of the finished flooring **52** is above, and not flush with, the closet flange **20**. To install the subject invention, prior to, during and/or after installation of the finished flooring **52**, one or more of the spacers **12** is laid atop the closet flange **20**. As explained in U.S. patent application Ser. No. 11/269,022 and PCT International Application No. PCT/US2006/10669, one or more of the spacers **12** (of the same or varying thicknesses) may be used to accommodate the thickness of the finished flooring **52** (e.g., two or more of the spacers **12** may be stacked). With the proper selection and placement of the spacer(s) **12** to equal or approximately the thickness of the finished flooring **52**, the closet flange insert **10** is placed atop the uppermost spacer **12** with the through pipe **16** extending through the spacer(s) **12**, particularly the opening(s) **44**, and into the pipe section **18** of the closet flange **20**. The through pipe **16** must have sufficient length to extend into the pipe section **18** when placed into use.

As shown in FIG. 5, it is preferred that the stacked arrangement of the spacer(s) **12** have generally the equal height of the finished flooring **52**. In this manner, lower face **56** of the closet flange insert **10** may be generally flush with the top surface **54** of the finished flooring **52**. As shown in FIG. 5, closet flange bolts **58** may be attached to the closet flange insert **10**, such as to the slots **34**, as is known in the art, with the closet flange bolts **58** resting on the uppermost spacer **12**. With this arrangement, a toilet may rest flush on the finished flooring **52** and be directly connected to the closet flange insert **10**, particularly at the flange **14**, without extenders or other devices.

To prevent gases from escaping from the soil pipe through the spacing between the closet flange **20** and the closet flange insert **10**, one or more seals **60** may be provided therebetween. The seals **60** may be wax rings or elastomeric elements, such as rubber rings. The seals **60** may be located anywhere between the closet flange insert **10** and the standard closet flange **20** so as to provide sufficient sealing to prevent gas venting or escaping about the closet flange insert **10**.

With reference to FIGS. 2 and 3, the closet flange insert **10** may be provided with a downwardly depending wall **62** extending from the flange **14**. Preferably, the wall **62** is annular and continuous, although it may be discontinuous to at least partially circumscribe the through pipe **16**. The wall **62** may define a diameter generally equal to the diameter of the opening(s) **44** of the spacer(s) **12** such that an outer surface of the wall **62** may be shape matingly received within the opening(s) **44**. With this configuration, the wall **62** may provide a centering effect, to locate the insert **10** centrally relative to the spacer(s) **12**. In addition, the wall **62** defines a channel **64** with the through pipe **16**. The channel **64** may be shaped and positioned to receive one or more of the seals **60**. For example, a wax seal may be inserted into the channel **64** prior to assembly of the system. It is preferred that the wall **62** be formed such that any seal accommodated in the channel **64** may have a sufficient sealing effect beyond the wall **62** and in between the closet flange insert **10** and the

5

closet flange 20 (i.e., it is preferred that any accommodated seal extend sufficiently from the channel 64 to provide a sufficient sealing effect).

One or more fasteners 66 may be utilized to fasten the closet flange insert 10 to a surface in proximity to the closet flange 20, such as the sub-flooring 48. The fasteners 66 preferably pass through the annular flange 14, the spacer(s) 12, the closet flange 20 (particularly, the annular flange 28), and into the sub-flooring 48. Any known fasteners 66 may be used (e.g., screws, nails, rivets, etc.), and the fasteners 66 may be passed through the fastener holes 32 to limit stresses on the closet flange insert 10. The spacer(s) 12 may also be provided with fastener holes 68 (FIG. 4), as disclosed in U.S. patent application Ser. No. 11/269,022 and PCT International Application No. PCT/US2006/10669.

With reference to FIGS. 6 and 7, to ensure proper centering of the closet flange insert 10, and as an alternative to the wall 62, one or more ribs 70 may be provided to extend from the bottom of the annular flange 14 with end points 72 generally coinciding with the diameter of the opening(s) 44 of the spacer(s) 12. With this arrangement, the spacer(s) 12 may be evenly centered about the closet flange insert 10.

As shown in the Figures, it is preferred that the closet flange insert 10 be unitary. The insert 10 may be formed from any material, including polymeric material or metallic material (such as cast iron). The insert 10 may be formed from plastic, which is well-suited to be molded (e.g., injection molded). The insert 10 may be colored. With coloring, the insert 10 may be made visually easy to spot. Also, the insert 10 may be colored to be readily distinguishable from other building materials, particularly piping. Where standard polyvinyl chloride (PVC) piping, which is white, is being used, the insert may be colored red, and where standard acrylonitrile butadiene styrene (ABS) piping, which is black, is being used, the insert 10 may be made white and/or red.

What is claimed is:

1. A method of providing a flange for connecting to a toilet above an installed closet flange, the installed closet flange having a pipe section and an annular flange extending radially outwardly from the pipe section, said method comprising the steps of:

providing a closet flange insert having a body having a through pipe and an annular toilet connecting flange extending radially outwardly from said through pipe, said through pipe being sized to be inserted into the pipe section of the installed closet flange, said toilet connecting flange being sized to at least partially overlie the annular flange of the installed closet flange;

disposing at least one spacer atop the installed closet flange, each said spacer having a body defining an opening which permits passage therethrough of said through pipe of said closet flange insert but not said toilet connecting flange of said closet flange insert;

inserting said through pipe of said closet flange insert through said opening of each said spacer and into the pipe section of the installed closet flange; and,

fastening said closet flange insert to a surface in proximity to the installed closet flange,

wherein a lower face of said toilet connecting flange is generally flush with the top of finished flooring located about, and protruding above, the installed closet flange.

6

2. A method as in claim 1, further comprising the step of disposing at least one seal between said closet flange insert and the installed closet flange.

3. A method as in claim 1, wherein said toilet connecting flange is generally sized and shaped same as the annular flange of the installed closet flange.

4. A combination comprising:

a closet flange insert for defining a flange for connecting to a toilet located above an installed closet flange, the installed closet flange having a pipe section and an annular flange extending radially outwardly from the pipe section, said closet flange insert comprising:

a body having a through pipe and an annular toilet connecting flange extending radially outwardly from said through pipe, said through pipe being sized to be inserted into the pipe section of the installed closet flange, said toilet connecting flange being sized to at least partially overlie the annular flange of the installed closet flange, at least one fastener hole being formed to extend through said toilet connecting flange,

wherein an arcuate wall depends from said toilet connecting flange to at least partially circumscribe said through pipe, said arcuate wall being spaced radially inwardly of an outer edge of said toilet connecting flange, and

wherein, when said through pipe is inserted into the pipe section of the installed closet flange, a lower face of said toilet connecting flange is configured to be generally flush with a top of finished flooring located about, and protruding above, the installed closet flange; and

at least one wax ring seated at least partially between said arcuate wall and said through pipe.

5. A combination as in claim 4, wherein said arcuate wall fully circumscribes said through pipe.

6. A method of providing a flange for connecting to a toilet above an installed closet flange, the installed closet flange having a pipe section and an annular flange extending radially outwardly from the pipe section, said method comprising the steps of:

providing a closet flange insert having a body having a through pipe and an annular toilet connecting flange extending radially outwardly from said through pipe, said through pipe being sized to be inserted into the pipe section of the installed closet flange, said toilet connecting flange being sized to at least partially overlie the annular flange of the installed closet flange; inserting said through pipe of said closet flange insert through at least one wax ring;

inserting said through pipe of said closet flange insert into the pipe section of the installed closet flange; and, fastening said closet flange insert to flooring with fasteners passing through said closet flange insert and into the flooring,

wherein, with said closet flange insert fastened to the flooring, a lower face of said toilet connecting flange is generally flush with the top of finished flooring located about, and protruding above, the installed closet flange.

7. A method as in claim 6, wherein said fasteners are screws.

* * * * *