

US00RE47724E

(19) **United States**  
(12) **Reissued Patent**  
**Williams**

(10) **Patent Number: US RE47,724 E**  
(45) **Date of Reissued Patent: \*Nov. 12, 2019**

- (54) **EYEWEAR RETENTION DEVICE**
- (71) Applicant: **CABLZ, INC.**, Birmingham, AL (US)
- (72) Inventor: **Ronald Wade Williams**, Birmingham, AL (US)
- (73) Assignee: **CABLZ, INC.**, Birmingham, AL (US)
- (\* ) Notice: This patent is subject to a terminal disclaimer.
- (21) Appl. No.: **13/660,706**
- (22) Filed: **Oct. 25, 2012**

**Related U.S. Patent Documents**

Reissue of:

- (64) Patent No.: **7,845,795**  
Issued: **Dec. 7, 2010**  
Appl. No.: **12/647,307**  
Filed: **Dec. 24, 2009**

U.S. Applications:

- (63) Continuation-in-part of application No. PCT/US2009/043156, filed on May 7, 2009, and a continuation-in-part of application No. 29/336,725, filed on May 7, 2009, now Pat. No. Des. 607,919.
- (60) Provisional application No. 61/051,539, filed on May 8, 2008.

- (51) **Int. Cl.**  
**G02C 3/00** (2006.01)
- (52) **U.S. Cl.**  
CPC ..... **G02C 3/003** (2013.01)
- (58) **Field of Classification Search**  
CPC ..... **G02C 3/003**  
USPC ..... **351/156, 157, 158, 41; 2/452; D16/339, D16/329, 101, 300-324**  
See application file for complete search history.

(56) **References Cited**

U.S. PATENT DOCUMENTS

182,013 A	9/1876	Andross
1,026,272 A	5/1912	Leveque

(Continued)

FOREIGN PATENT DOCUMENTS

AU	680188	7/1997
DE	29908337 U1	11/1999

(Continued)

OTHER PUBLICATIONS

Monroe, B. "Outdoor folks don't use trendy glasses-holders." *The Oregonian*. (Jul. 4, 1991), p. E4.\*

(Continued)

*Primary Examiner* — Sara S Clarke

(74) *Attorney, Agent, or Firm* — C. Brandon Browning; Maynard, Cooper & Gale, PC

(57) **ABSTRACT**

An adjustable eyewear retention device [having two] comprising a resilient elongate member adjustable in length, such as a pair of cables, [two] and a pair of temple retainers connected to one another by the elongate member, [guiding means and grasping means which allow adjustment of the device to the dimensions of a user's head. In another embodiment, the guiding means is eliminated and the cables are connected by means of the grasping means] such that when the temple retainers are attached to the temples of a pair of eyeglasses and the eyeglasses are worn by a wearer, the resilient member forms an arc suspended off the wearer's neck.

**13 Claims, 9 Drawing Sheets**

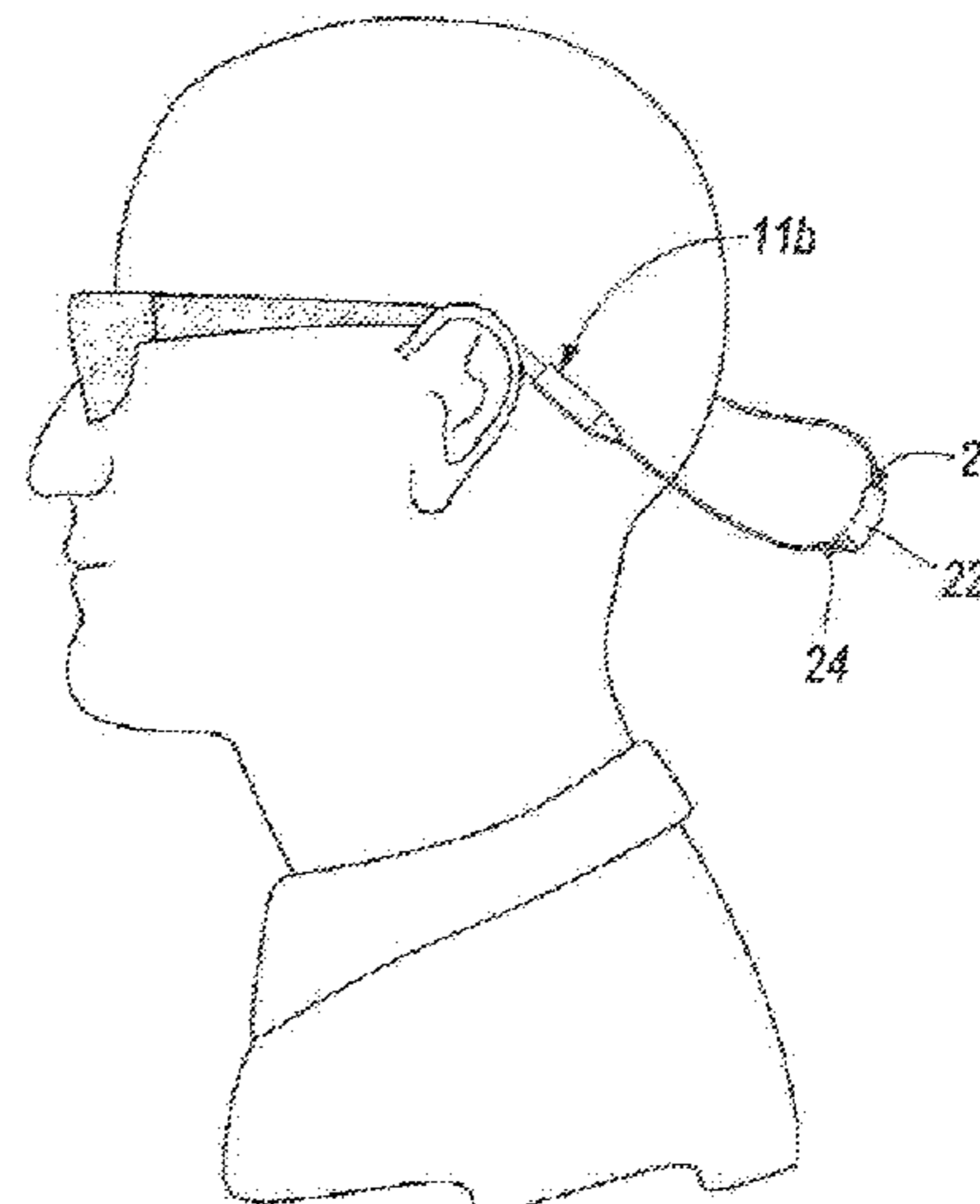
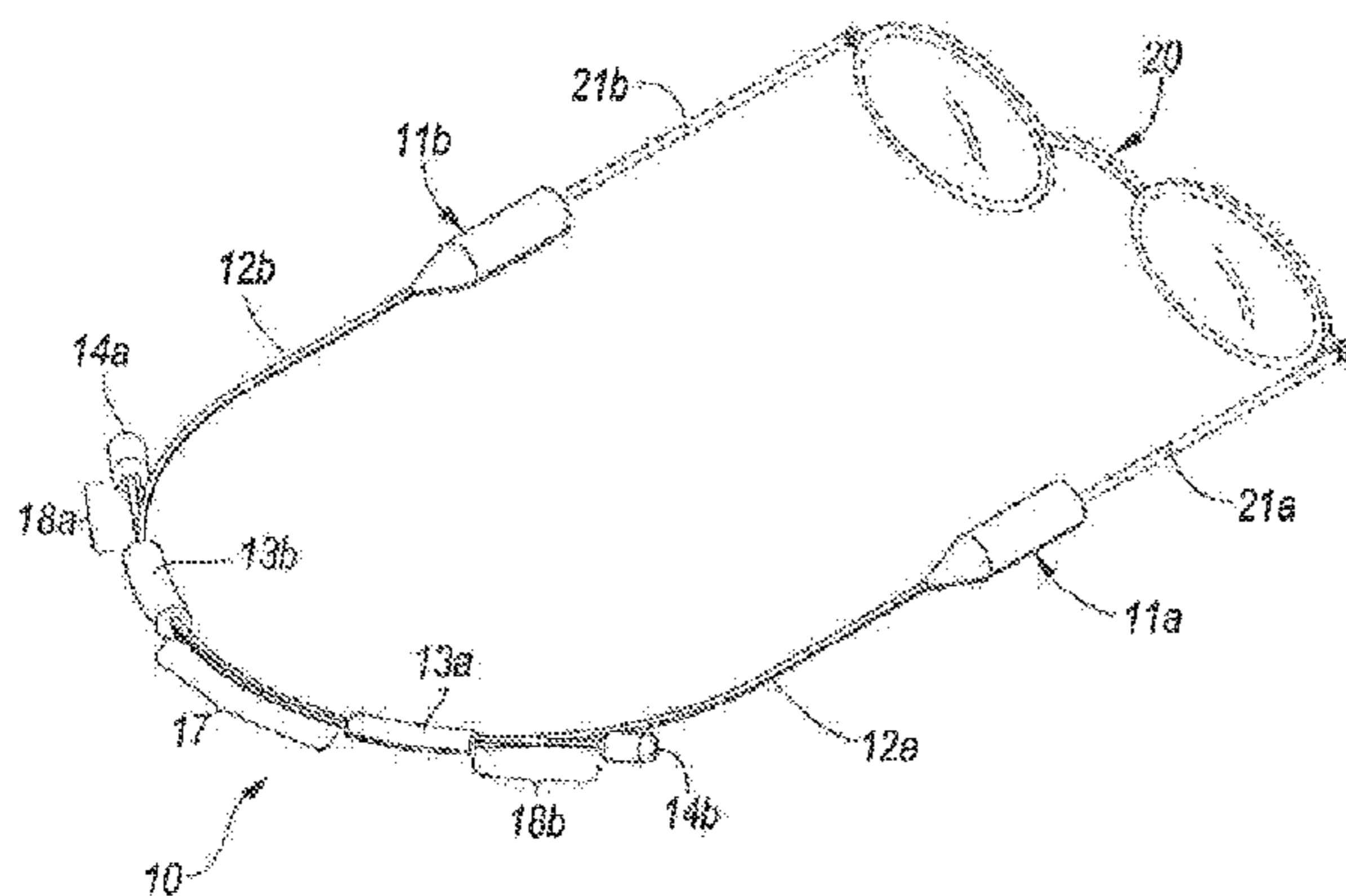

(56)

References Cited

U.S. PATENT DOCUMENTS

1,819,738	A *	8/1931	Daniels	.....	G02C 3/003 351/156
2,704,961	A	3/1955	Weil	.....	351/157
3,450,467	A *	6/1969	Phillips	.....	351/157
3,673,610	A	7/1972	Liautaud		
3,728,012	A	4/1973	Downey		
4,133,604	A	1/1979	Fuller	.....	351/123
4,541,696	A	9/1985	Winger		
4,692,002	A	9/1987	Meistrell		
4,696,556	A	9/1987	Perry		
4,793,702	A	12/1988	Ahrens		
4,820,036	A	4/1989	Seet		
4,922,581	A	5/1990	Wilson		
4,955,710	A	9/1990	Meistrell		
5,015,085	A	5/1991	May		
5,074,565	A	12/1991	Parrish		
5,092,668	A	3/1992	Welch	.....	351/156
D328,908	S	8/1992	Kalbach		
5,181,052	A	1/1993	McClellan		
5,191,363	A	3/1993	Smith		
5,247,814	A *	9/1993	McDonald	.....	63/3.2
5,369,542	A	11/1994	Leone et al.		
5,384,605	A	1/1995	Escobosa		
5,390,434	A	2/1995	Lockard		
5,575,042	A	11/1996	Kalbach	.....	24/3.3
5,664,291	A *	9/1997	Stoller	.....	24/3.3
5,735,393	A	4/1998	Hermansen		
D411,562	S	6/1999	Riley		
6,053,612	A	4/2000	MacIntosh		
D424,600	S	5/2000	Riley		
D432,556	S	10/2000	Lando		
6,182,334	B1	2/2001	Davancens		
6,233,345	B1	5/2001	Urwyler		
6,247,811	B1	6/2001	Rhoades		
6,478,419	B1	11/2002	McDaniel		
6,629,760	B1	10/2003	Razin		
6,644,803	B1	11/2003	Liu		
6,644,808	B1	11/2003	Liu	.....	351/156
D486,174	S	2/2004	Chisolm		
D486,511	S	2/2004	Kalbach		
6,690,808	B2	2/2004	Urwyler		
6,709,100	B2	3/2004	Kalbach		
6,736,504	B1	5/2004	Hermesen		
6,764,177	B1	7/2004	Chisolm		
6,817,069	B1	11/2004	Tillstrom		
6,941,619	B2	9/2005	MacKay	.....	24/3.3
D513,519	S	1/2006	Chisolm		
D536,364	S	2/2007	Kalbach		
7,284,855	B2	10/2007	Bent	.....	351/156
D567,279	S	4/2008	Chisolm		
7,467,867	B1	12/2008	Williams	.....	351/156
D588,184	S	3/2009	Lane		
D590,008	S	4/2009	Lane		
D590,009	S	4/2009	Lane		
D590,344	S	4/2009	Suematsu et al.		
D607,919	S *	1/2010	Williams	.....	D16/339
7,780,289	B2	8/2010	Pettingill		
7,828,429	B2	11/2010	Spinnato		
7,926,937	B2	4/2011	Spinnato		
8,092,009	B2	1/2012	Williams		
8,366,268	B2	2/2013	Williams		
2007/0046889	A1	3/2007	Miller		
2007/0248238	A1	10/2007	Abreu		

FOREIGN PATENT DOCUMENTS

EP	0537390	A1	10/1991
GB	2280042		1/1995
WO	0053269	A1	9/2000

OTHER PUBLICATIONS

Kalan, Administrative Patent Judge "Decision Institution of Inter Partes Review 37 C.F.R. 42.108" United States Patent and Trade-

mark Office/Before the Patent Trial and Appeal Board/*Chums, Inc., and Croakies, Inc.*, Petitioners v. *CABLZ, Inc.* Patent Owner/Case IPR 2014-01240 U.S. Pat. No. 8,366,268 B2; Paper 10; Issued Feb. 10, 2015; pp. 1-19.  
 John Krisik "Transmittal letter enclosing samples of the Croakies Braided Leather Sport Eyewear Retainer" Feb. 12, 2014; 1 page.  
 Expert Report of Beirne Chisolm in *Cablz, Inc. v. Chums, Inc.*, Aug. 21, 2014 (revised).  
 Expert Report of Lee Moradi in *Cablz, Inc. v. Chums, Inc.*, Jun. 30, 2014.  
 Expert Report of Joe Jernigan in *Cablz, Inc. v. Chums, Inc.*, Jun. 30, 2014.  
 Expert Report of Steven Visser in *Cablz, Inc. v. Chums, Inc.*, May 30, 2014.  
 Expert Report of Steven Visser in *Cablz, Inc. v. Chums, Inc.* Aug. 1, 2014.  
 Expert Report of Mark Sosin in *Cablz, Inc. v. Chums, Inc.* Aug. 1, 2014.  
 Expert Report of Kevin Banks in *Cablz, Inc. v. Chums, Inc.* Aug. 1, 2014.  
 Discovery Response of Cablz, Inc. in *Cablz, Inc. v. Chums, Inc.* Apr. 23, 2014.  
 Discovery Response of Cablz, Inc. in *Cablz, Inc. v. Chums, Inc.* Jul. 18, 2014.  
 Discovery Response of Chums Inc. in *Cablz, Inc. v. Chums, Inc.* Apr. 22, 2014.  
 Discovery Response of Chums Inc. in *Cablz, Inc. v. Chums, Inc.* Jul. 18, 2014.  
 Counterclaim of Croakies, Inc. in *Cablz, Inc. v. Croakies* May 30, 2014.  
 Cablz, Inc.'s Motion to Dismiss Counterclaim of Croakies, Inc. in *Cablz, Inc. v. Croakies* Jul. 11, 2014.  
 Petition for Inter Partes Review of Chums, Inc. and Croakies, Inc. #IPR2014-01240; Aug. 1, 2014.  
 Sunbelt Retainer.  
 Andres, Kenneth, Deposition of in *Cablz, Inc. v. Chums, Inc.* Jul. 17, 2014.  
 Banks, Kevin, Deposition of in *Cablz, Inc. v. Chums, Inc.* Aug. 21, 2014.  
 Chisolm, Beirne, Deposition of in *Cablz, Inc. v. Chums, Inc.* Aug. 22, 2014.  
 Ferries, Tom, Deposition of in *Cablz, Inc. v. Chums, Inc.* Aug. 19, 2014.  
 Jernigan, Joe, Deposition of in *Cablz, Inc. v. Chums, Inc.* Aug. 12, 2014.  
 Krisik, John, Deposition of in *Cablz, Inc. v. Chums, Inc.* Jun. 5, 2014.  
 Moradi, Lee, Deposition of in *Cablz, Inc. v. Chums, Inc.* Aug. 28, 2014.  
 Nussman, Michael, Deposition of in *Cablz, Inc. v. Chums, Inc.* Jul. 17, 2014.  
 Sosin, Mark, Deposition of in *Cablz, Inc. v. Chums, Inc.* Aug. 19, 2014.  
 Visser, Steven, Deposition of in *Cablz, Inc. v. Chums, Inc.* Aug. 15, 2014.  
 Williams, Holly, Deposition of in *Cablz, Inc. v. Chums, Inc.* Jul. 9, 2014.  
 Williams, Holly, Deposition of in *Cablz, Inc. v. Chums, Inc.* Aug. 29, 2014.  
 Williams, Ron, Deposition of in *Cablz, Inc. v. Chums, Inc.* Aug. 1, 2014.  
 Proposed Amended Counterclaim of Chums in *Cablz, Inc. v. Chums, Inc.* Jul. 23, 2014.  
 First Package Jul. 2008.  
 Yellow Mannequin Jul. 2008.  
 Product Flyer Jul. 2008.  
 Second Package Dec. 2008.  
 Jan. 2009 Show Literature.  
 First Brochure Apr. 2009.  
 Third Package Apr. 2009.

\* cited by examiner



FIG. 1

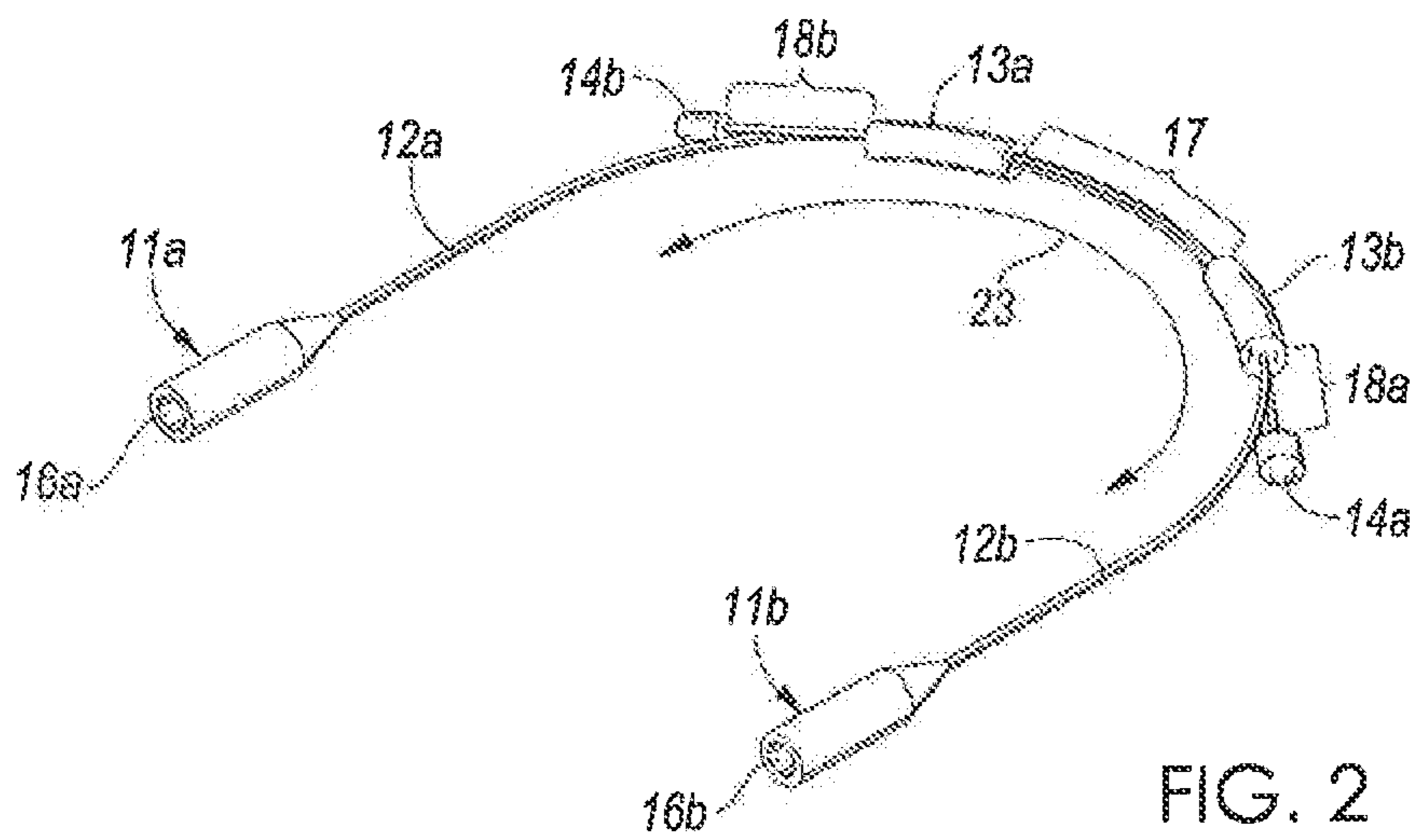
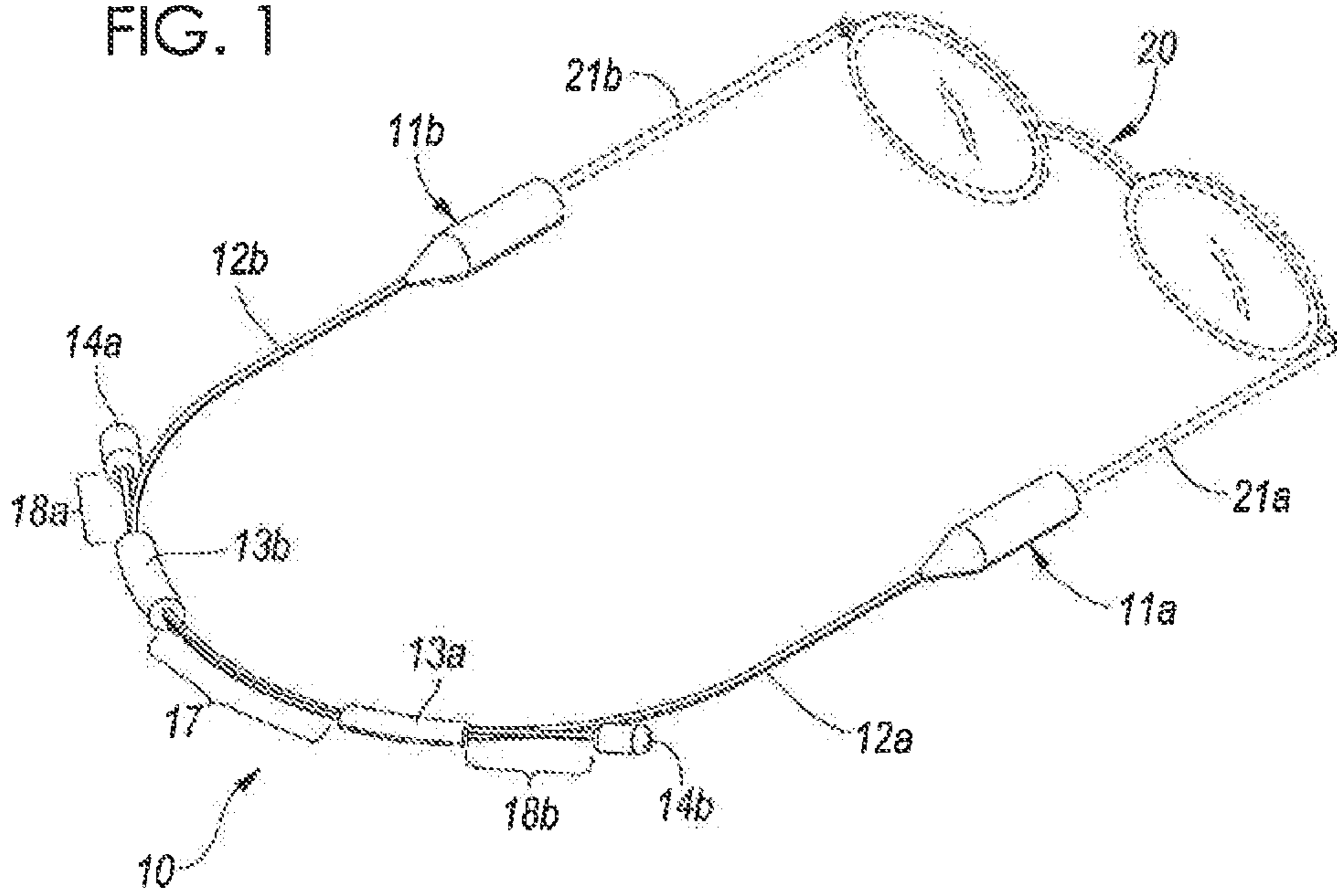

FIG. 2

FIG. 3

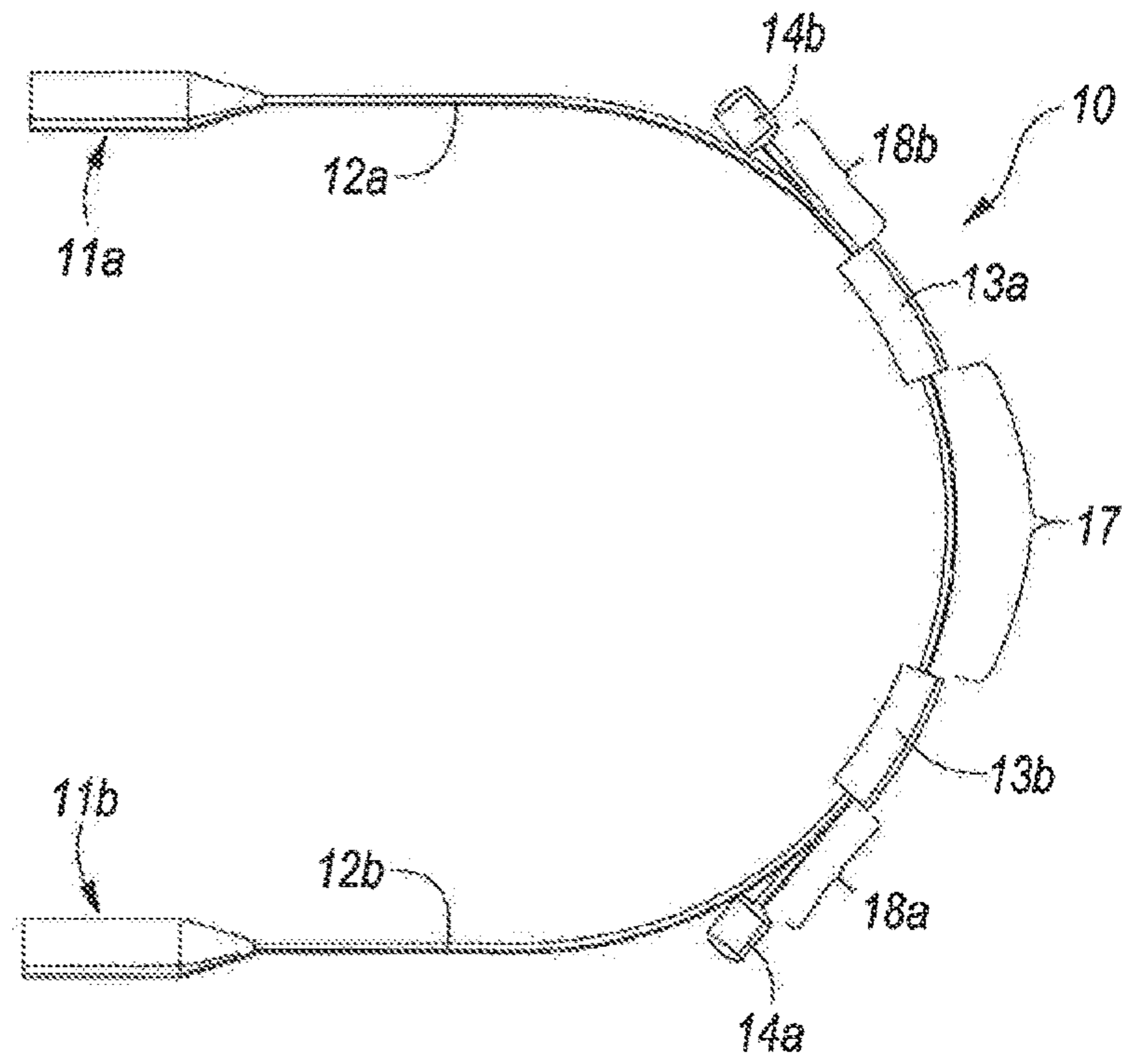
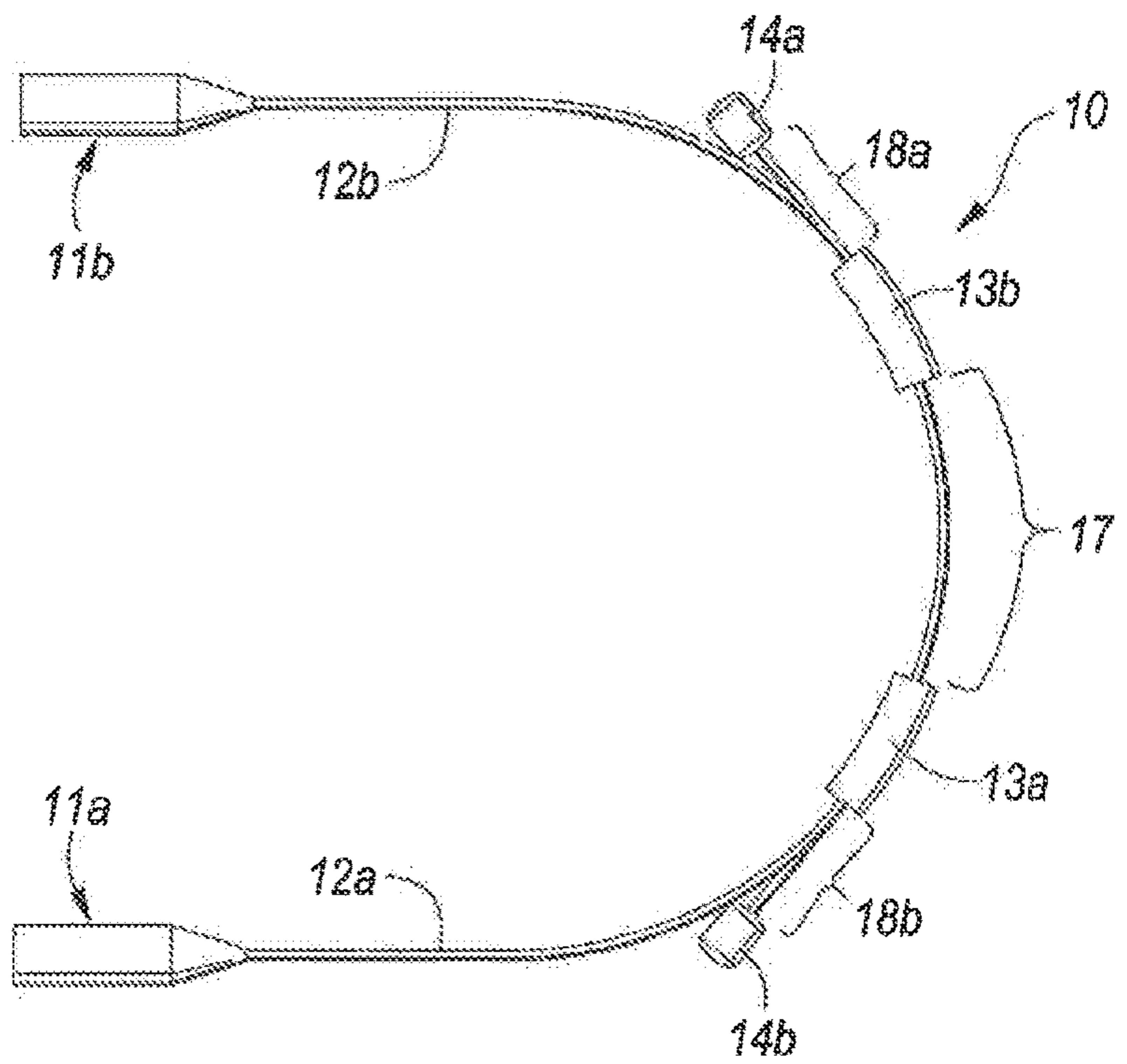

FIG. 4



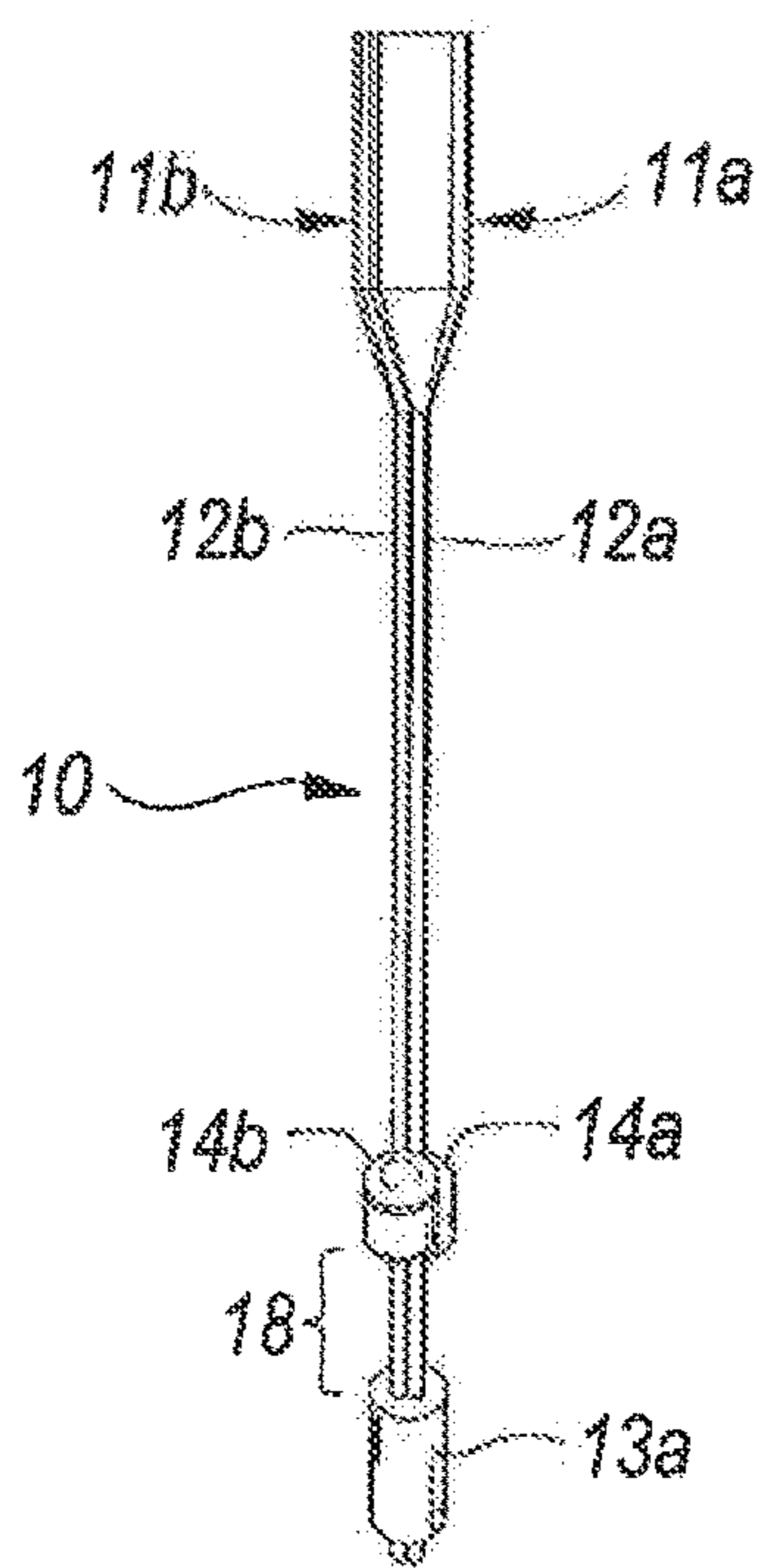

FIG. 5

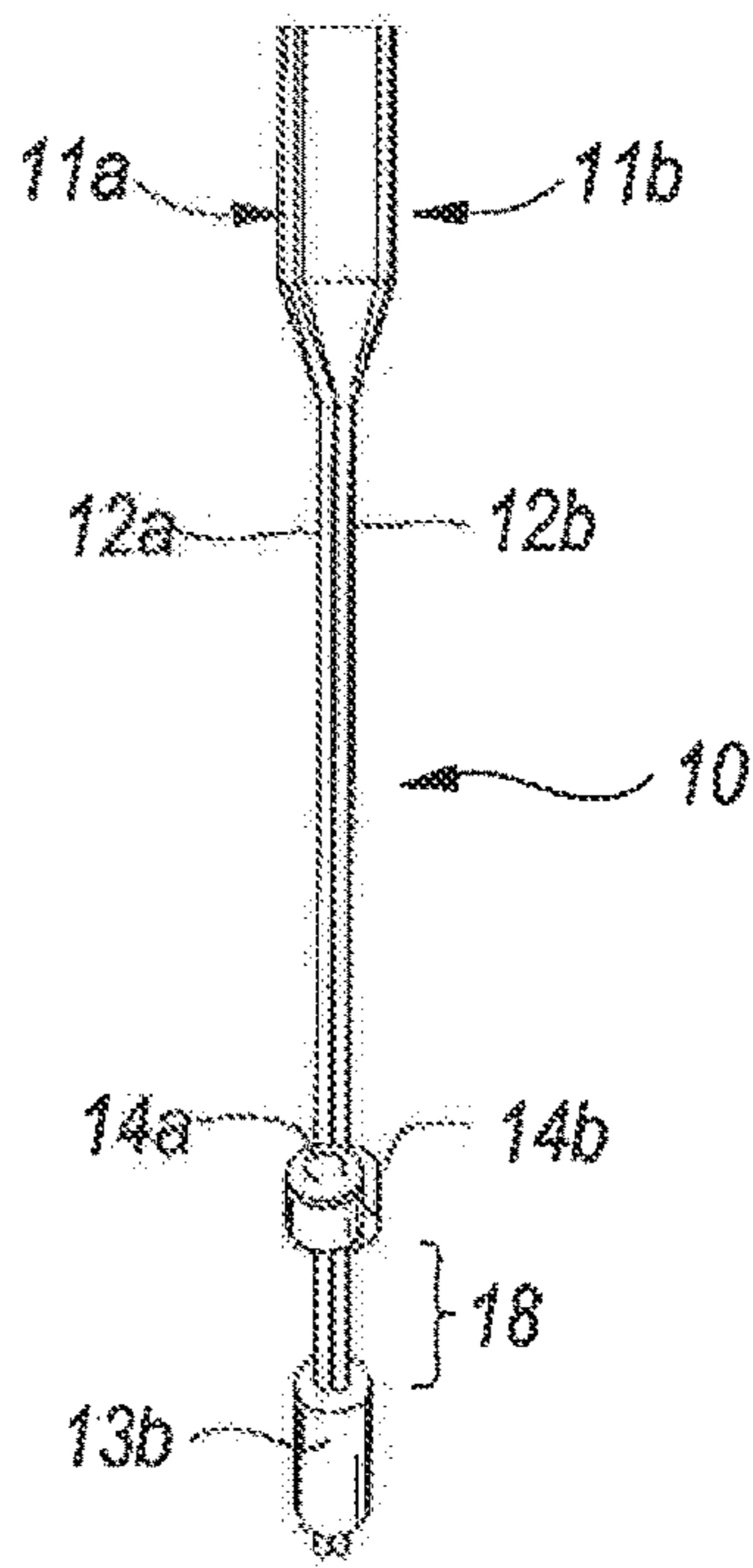

FIG. 6

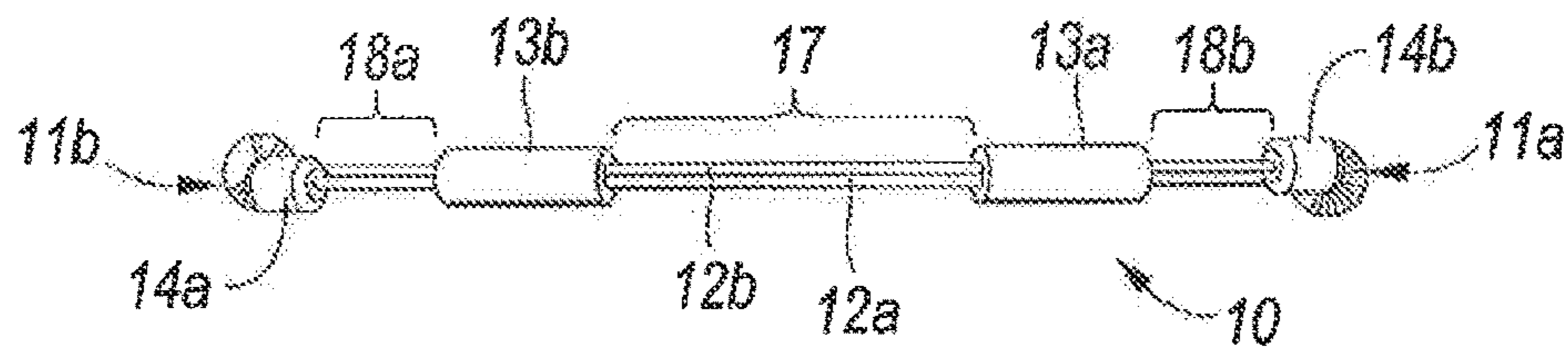

FIG. 7

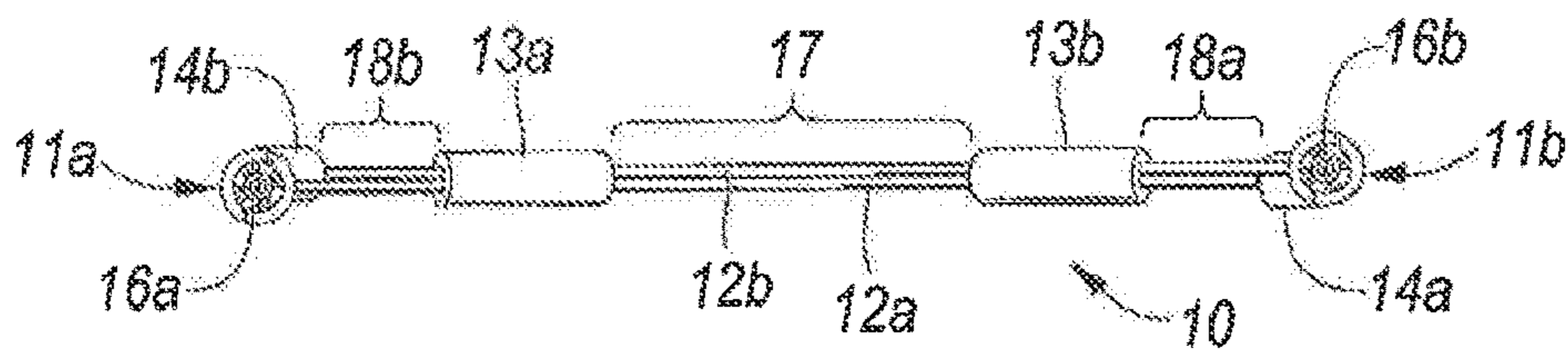

FIG. 8

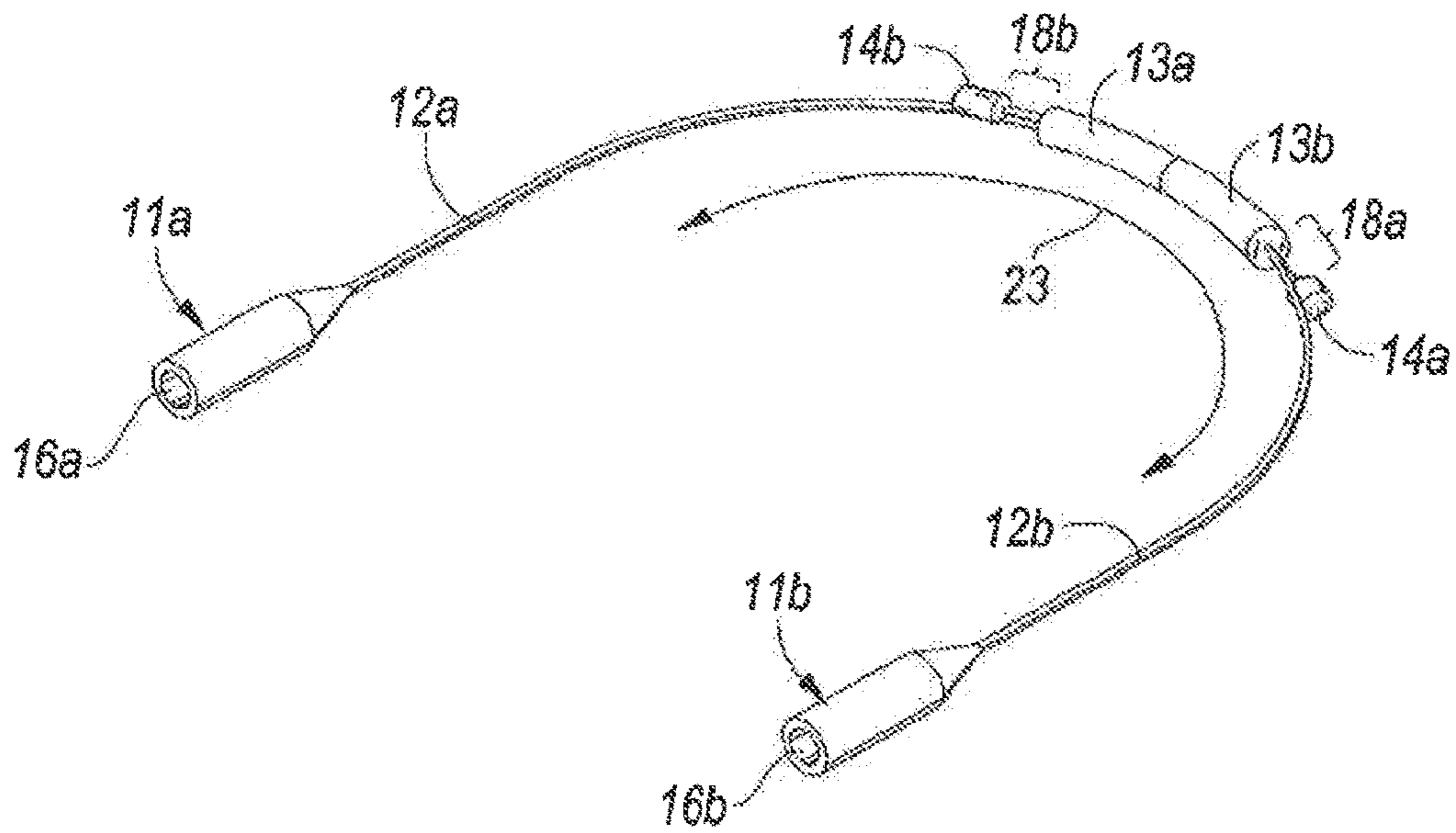

FIG. 9

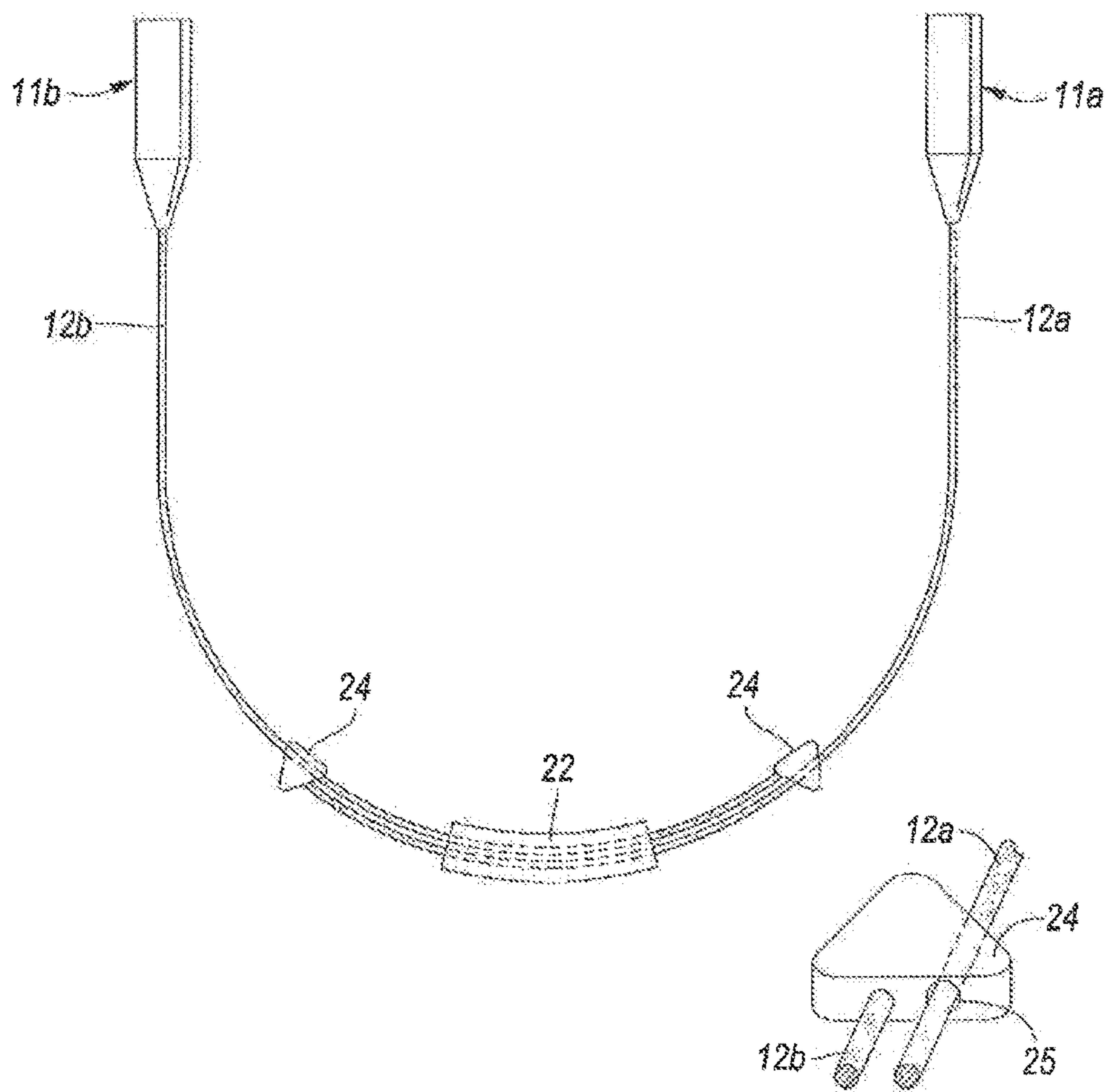

FIG. 10

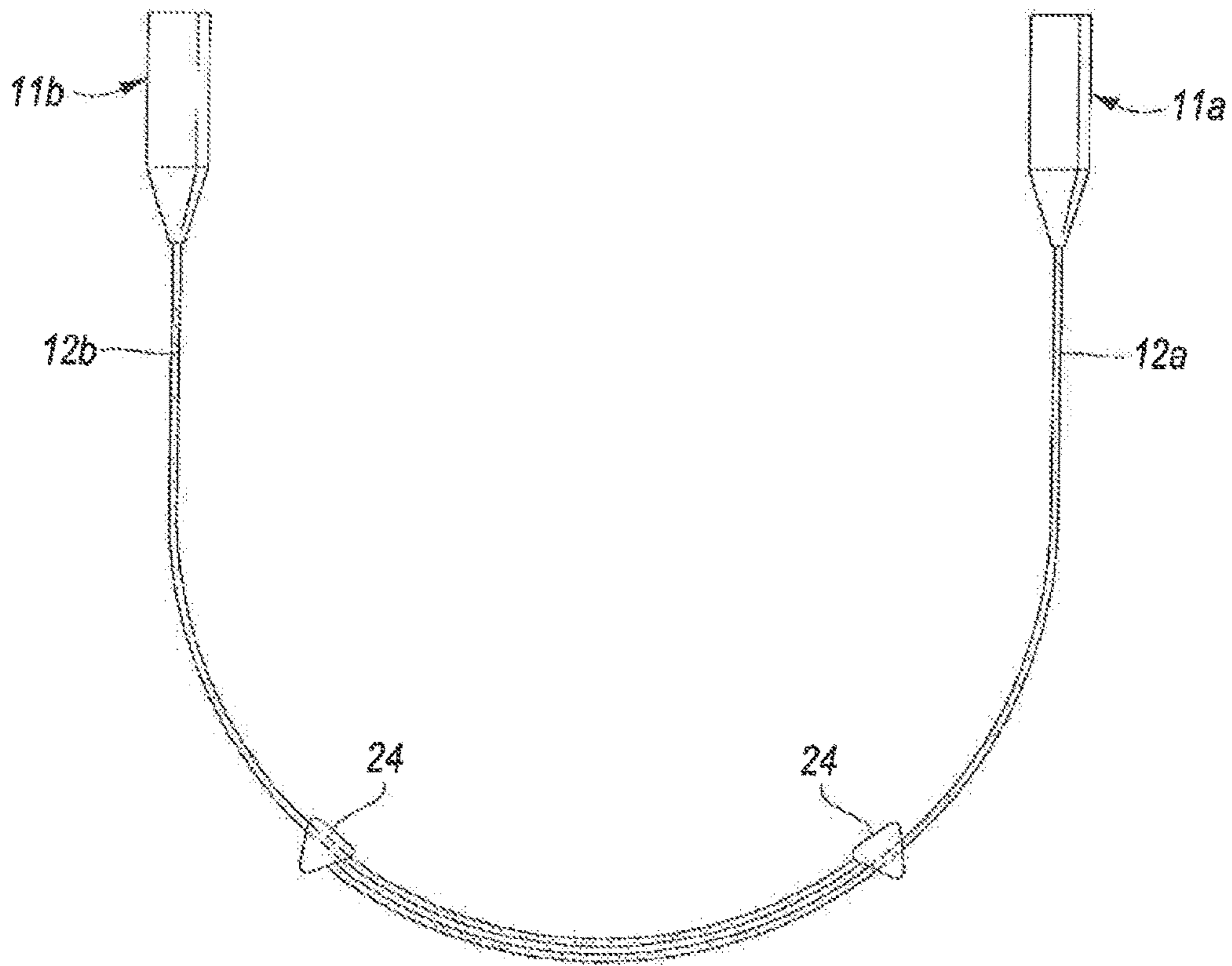

FIG. 11



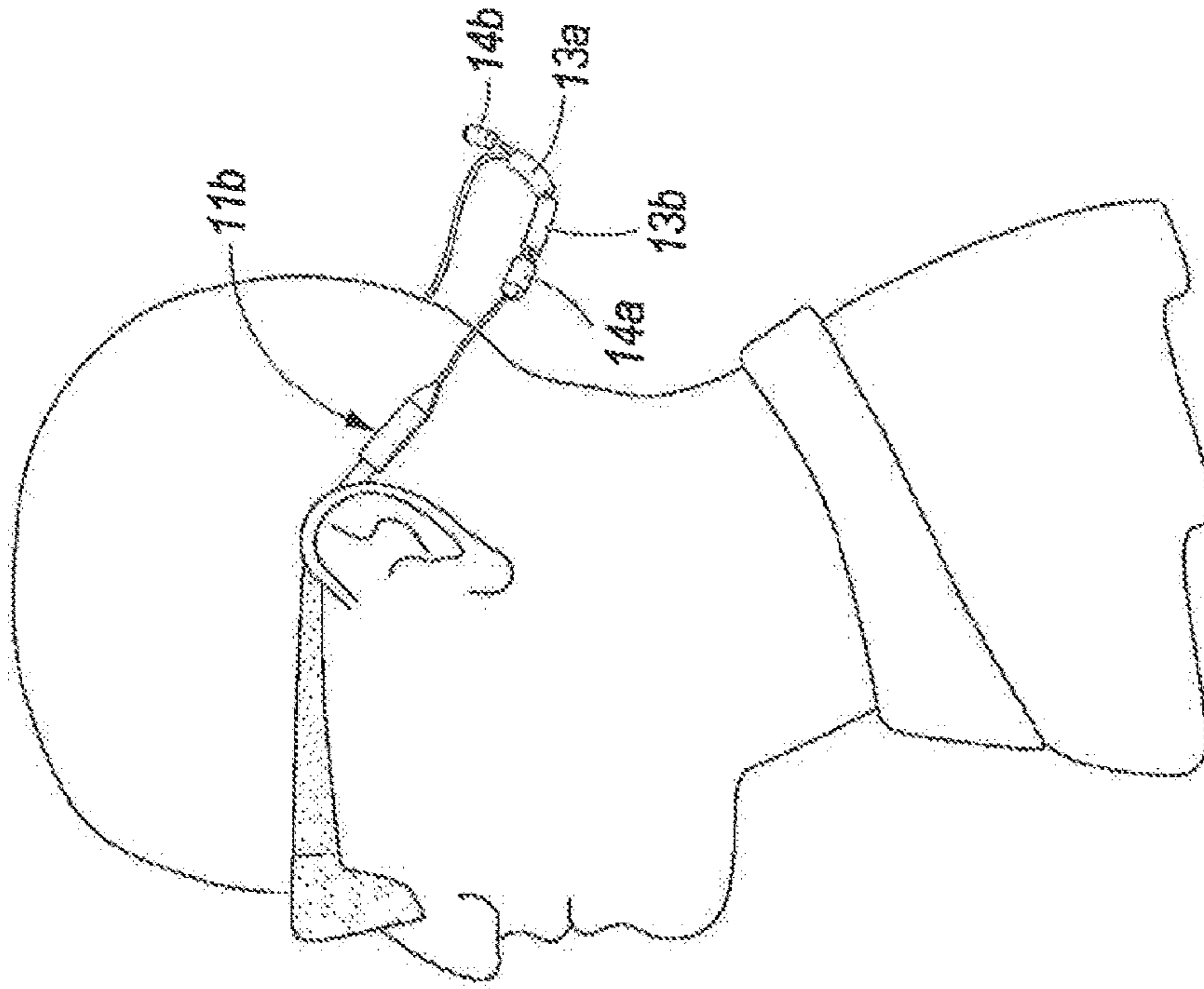

FIG. 12A

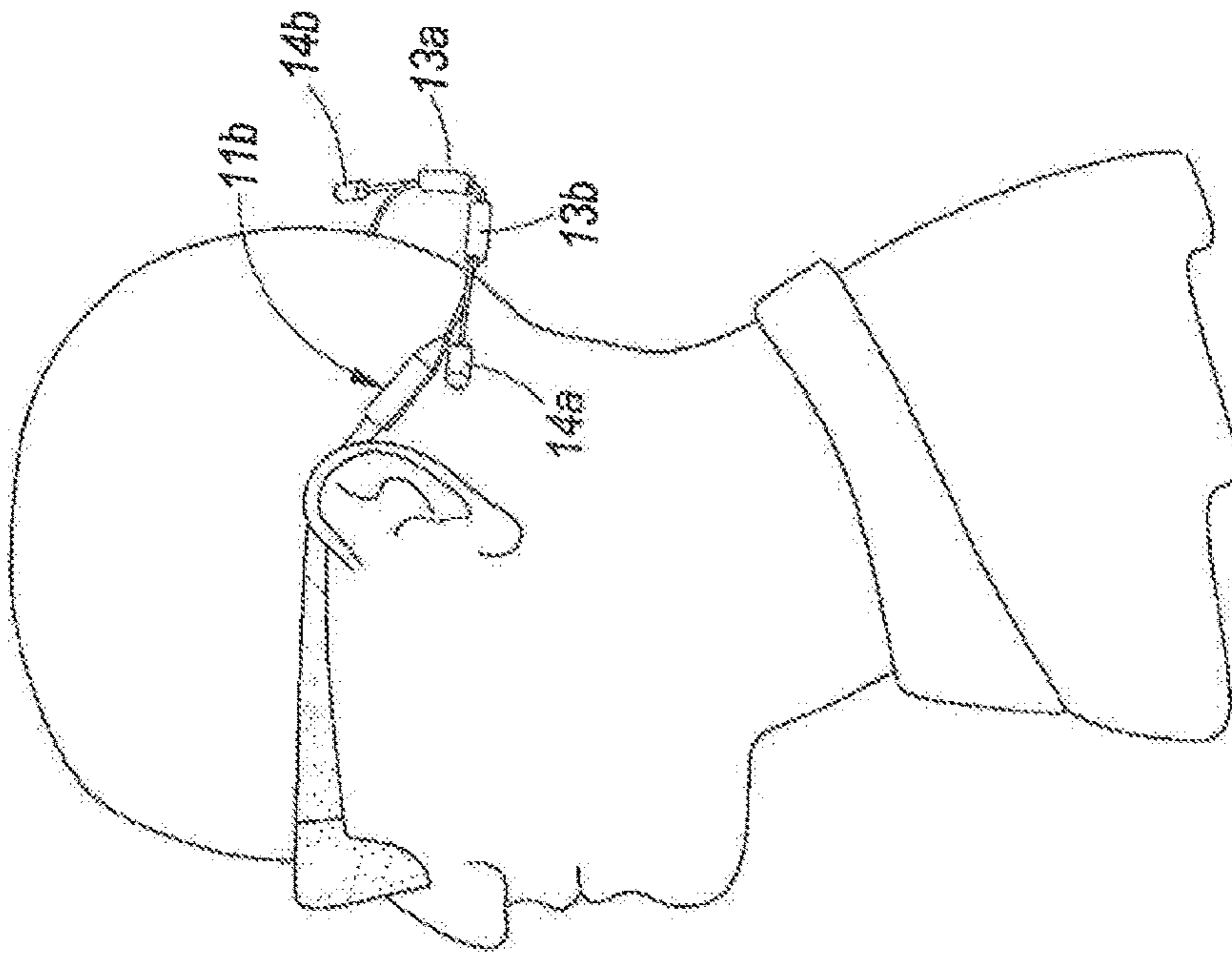

FIG. 12B

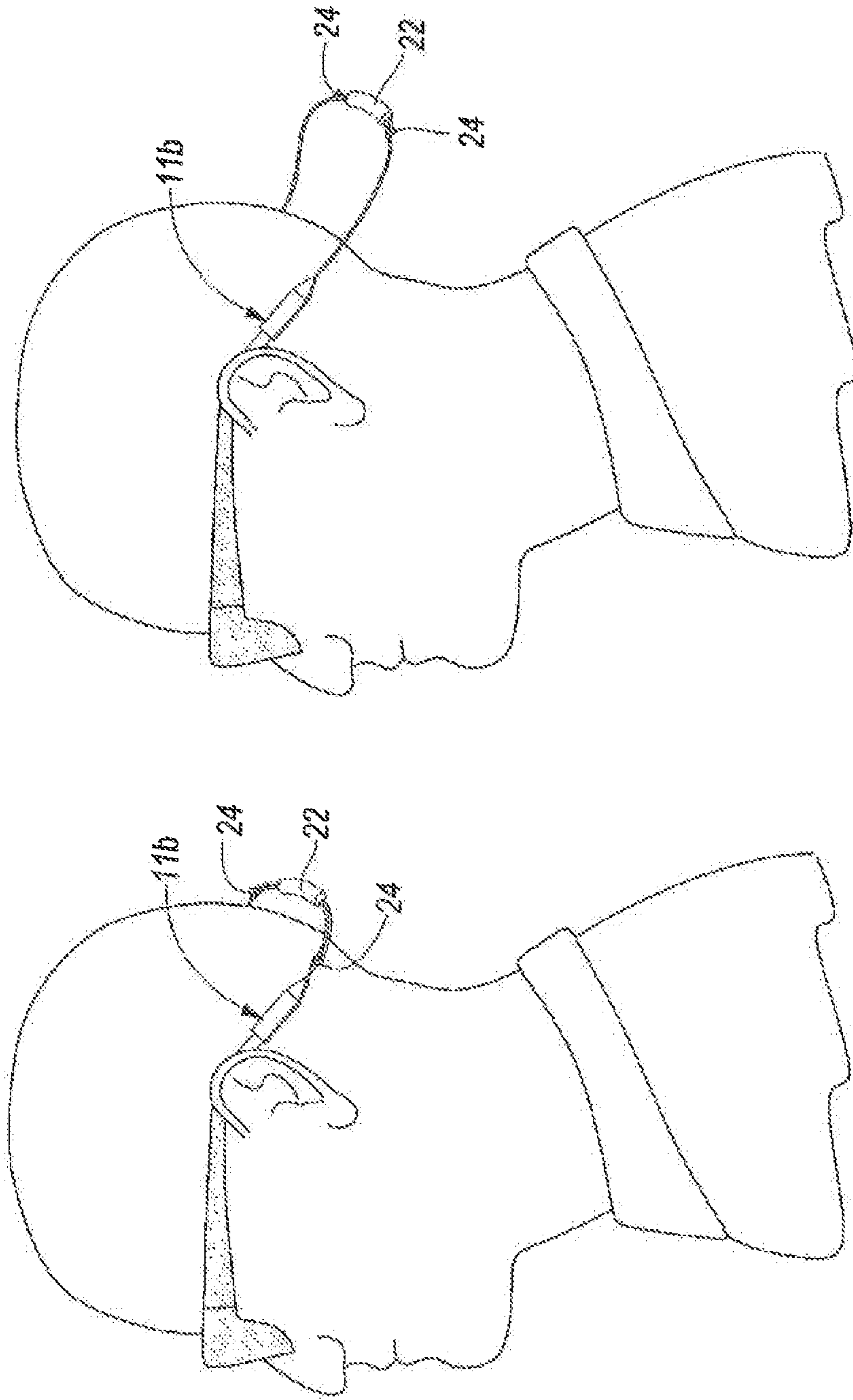

FIG. 13B

FIG. 13A

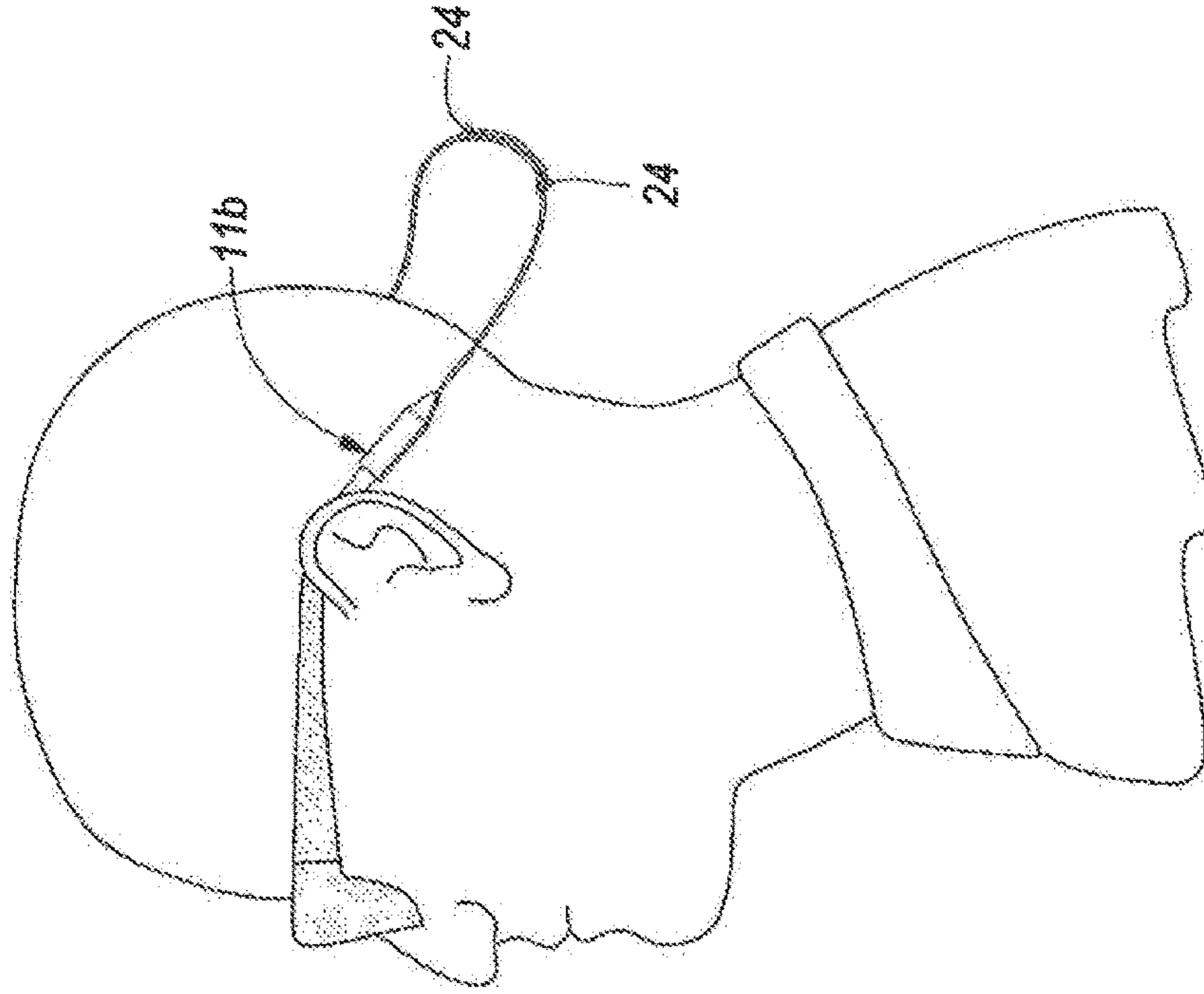

FIG. 14A

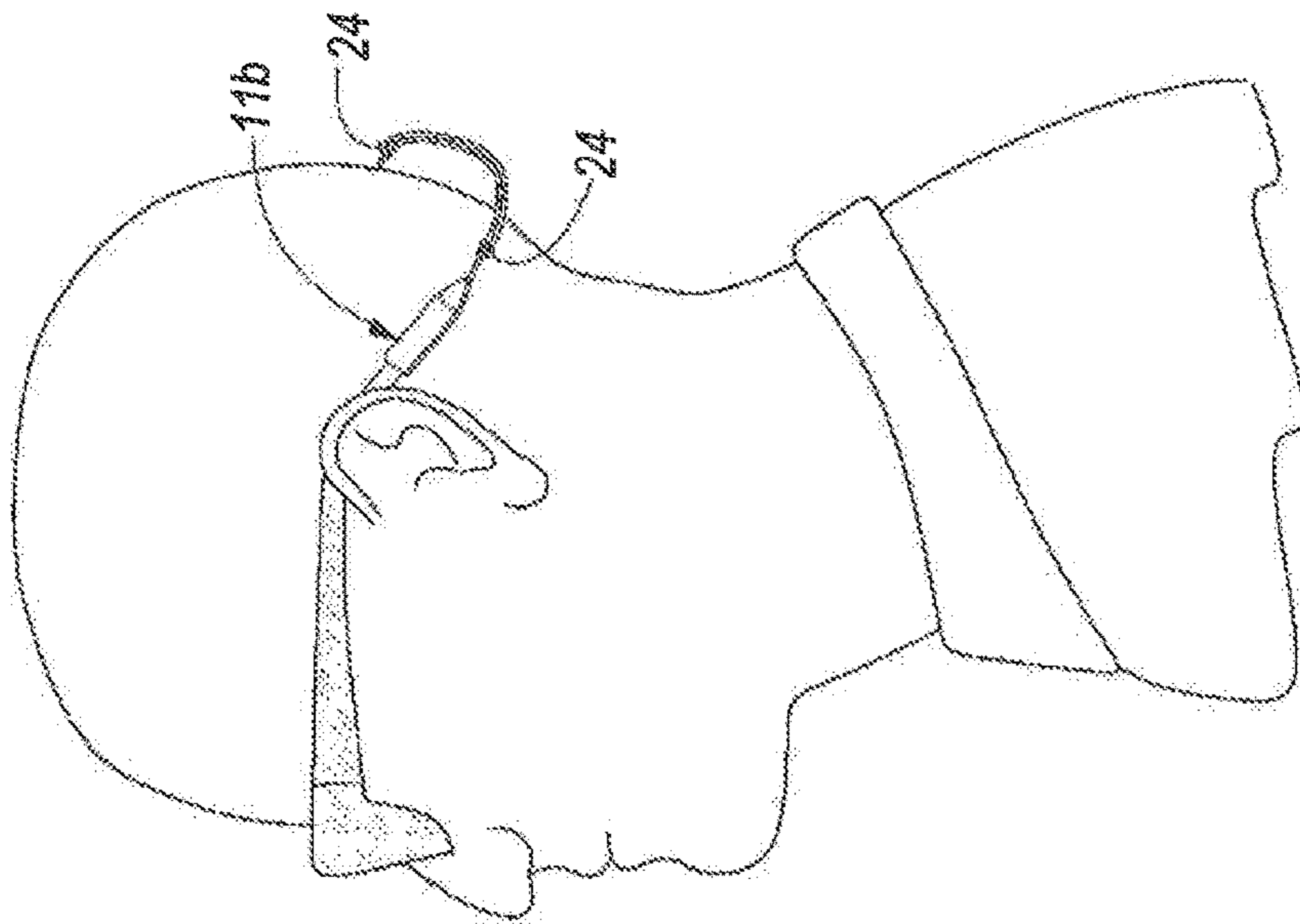

FIG. 14B



## EYEWEAR RETENTION DEVICE

**Matter enclosed in heavy brackets [ ] appears in the original patent but forms no part of this reissue specification; matter printed in italics indicates the additions made by reissue; a claim printed with strikethrough indicates that the claim was canceled, disclaimed, or held invalid by a prior post-patent action or proceeding.**

[This is a utility continuation of design patent application 29/336,725 entitled "Adjustable Eyewear Retention Device."] *This application is a continuation-in-part of PCT Application No. PCT/US09/43156 filed May 7, 2009 (now expired), which claims priority to U.S. Provisional Application No. 61/051,539, filed May 8, 2008 (now expired). This application is a continuation of U.S. patent application Ser. No. 29/336,725 filed May 7, 2009, now U.S. Pat. D607,919.*

## FIELD OF INVENTION

The present invention relates generally to devices that retain eyewear on a user.

## BACKGROUND OF THE INVENTION

U.S. Pat. No. 7,467,867 issued to Williams discloses an eyewear retention device having two temple retainers connected by a cable which, when attached to eyeglasses and worn over the ears by a user, maintains a suspended arc over the wearer's neck, shoulders or garments. Williams' design, however, does not specifically address the need for holding the eyewear securely against a user's face during rigorous activity.

What is needed is a superior eyewear retainer design that incorporates adjustability in its structure so that a wearer may easily disengage the retention device in an adjustable fashion and maintain the advantages of the suspended arc in Williams.

## SUMMARY OF INVENTION

An adjustable eyewear retention device is disclosed that includes two cables, two temple retainers (one at each end of the cable), and means for adjusting the cables at the back of a user's head. The two cables are the same length, partially overlap one another, and create an arc when the [invention] device is attached to eyeglasses. In one embodiment at least one guide for the two cables is provided. The guide contains at least one tunnel or hole which keeps the two cables in close proximity and also allows *at least one of* the two cables to pass through slideably. In one embodiment the guide has a tunnel for each of the two cables and, in another embodiment, the two cables pass through the same tunnel or hole in the guide. A tab for adjustment is secured to the end of each cable opposite the temple retainer. In one embodiment the tab also contains a tunnel or hole for allowing the other cable to pass through slideably, thus *acting as a guide and* keeping the other cable in a defined path in the arc. In another embodiment, the tab is secured only to the end of one cable and the other cable does not pass through the tab, so the cable with the tab in this embodiment is not in the defined path of the arc. In all embodiments of

the invention the tabs allow adjustment by increasing or decreasing the length of the arc.

## BRIEF DESCRIPTION OF THE DRAWINGS

An adjustable eyewear retention device incorporating the features of the invention is depicted in the attached figures:

FIG. 1 is a rear perspective view of *one embodiment* of the invention with two guides in combination with a pair of eyeglasses shown with broken lines appearing for illustrative purposes only.

FIG. 2 is a front perspective view of the [invention with two guides] *embodiment of FIG. 1.*

FIG. 3 is a top plan view of the [invention with two guides] *embodiment of FIG. 1.*

FIG. 4 is a bottom plan view of the [invention with two guides] *embodiment of FIG. 1.*

FIG. 5 is a left side elevational view of the [invention with two guides] *embodiment of FIG. 1.*

FIG. 6 is a right side elevational view of the [invention with two guides] *embodiment of FIG. 1.*

FIG. 7 is a rear elevational view of the [invention with two guides] *embodiment of FIG. 1.*

FIG. 8 is a front elevational view of the [invention with two guides] *embodiment of FIG. 1.*

FIG. 9 is a front perspective view of the [invention] *embodiment of FIG. 1* with [two] *the* guides adjusted to an ultimate closed position.

FIG. 10 is a top plan view of *another embodiment* of the invention, with [one guide and two tabs, each tab secured to the end of one cable and also having a tunnel for allowing the other cable to pass through slideably. Additionally, there is] an inset showing a close-up view of [the] *a* tab which secures the end of one of the cables and also has a tunnel to allow the other cable to pass slideably through the tab.

FIG. 11 is a top plan view of *another embodiment* of the invention [without a guide for the cables and two tabs, each tab secured to the end of one cable and also having a tunnel for allowing the other cable to pass through slideably].

FIG. 12 contains two left side views of the embodiment [with two guides as] *of FIG. 1* attached to eyeglass temples and worn over the ears, 12a showing the [invention] *device* adjusted inwardly toward the head, and 12b showing outward adjustment.

FIG. 13 contains two left side views of the embodiment [with one guide and tabs, each tab secured to the end of one cable and each tab disposed around the other cable and allowing the other cable to pass through slideably. The invention is shown] *of FIG. 10* attached to eyeglass temples and worn over the ears, 13a showing the [invention] *device* adjusted inwardly toward the head, and 13b showing outward adjustment.

FIG. 14 contains two left side views of the embodiment [without a guide and tabs each tab secured to the end of one cable and each tab disposed around the other cable and allowing the other cable to pass through slideably. The invention is shown] *of FIG. 11* attached to eyeglass temples and worn over the ears, 14a showing the [invention] *device* adjusted inwardly toward the head, and 14b showing outward adjustment.

## DESCRIPTION OF THE PREFERRED EMBODIMENT

Referring to the figures for a better understanding of the function and structure of [the] *various embodiments of the* invention, FIG. 1 shows *an embodiment* of the [invention]



*apparatus 10* connected with a pair of eyeglasses **20** in which temples **21** a,b are inserted into retainers **11** a,b and from which cables **12**a,b extend longitudinally away from retainers **11** a,b. The structure and functioning of retainers **11** and cables **12** is more fully described in U.S. Pat. No. 7,467,867 B1 and in U.S. patent application Ser. No. 12/640,872 which are hereby incorporated by reference in their entirety.

Referring now to FIG. 2, it may be seen that temples **21** of eyeglasses **20** are placed within apertures **16**a,b of retainers **11** and held fast within the temple retainers. Other means for retaining the temples to the [invention] *apparatus 10* are known to persons of ordinary skill in the art. Due to the resilient properties of cables **12**, the cables maintain an arcuate shape **23** around the rear of a wearer's head when attached to a pair of eyeglasses such that the cables and intersecting structures permitting the adjustability of [invention] *apparatus 10* will be suspended in an arc above the wearer's neck, shoulders or garments. This self-suspending positioning of the cables **12** prevents the [invention] *apparatus 10* generally, but especially the cables **12** from becoming soiled with debris from a wearer's skin or garments, and also prevents interference from the wearer's garments.

As shown, each cable **12** extends in an arc **23** around an overlapping portion of the other cable with one end of each cable secured to a tab **14**a,b. Preferably, cable **12** is composed of a resilient material, such as a plastic coated twisted metal cable, plastic monofilament line, or semi-solid plastic tubing. While the preferred embodiment utilizes plastic coated twisted metal cable, any of the other aforementioned resilient cables can be utilized with satisfactory results. Guides **13**a,b work cooperatively to hold cables **12**a,b together in close proximity to one another and, in one embodiment, are comprised of a hollow, relatively thick walled plastic material through which cables **12**a,b may pass simultaneously in parallel fashion. The guides may be constructed of any materials of sufficient strength. The guides **13**a,b each have a length sufficient to promote parallel positioning of cables **12**a,b such that each cable tracks the other around the arc **23**. Guides **13** may have a linear shape or may also, preferably, have a slightly arcuate shape to further promote arc **23**. Guides **13**a,b each may have a single tunnel providing sufficient space to allow the cables **12**a,b to pass through simultaneously, against one another, and in a parallel traversing configuration. However, in the preferred embodiment, the passage of cables **12** through guide **13** fit snugly within guide **13** in twin hollow longitudinal tunnels in the guide **13**, each tunnel in close proximity to the other, but separate. Each tunnel is sized such that the tunnel walls exert frictional forces on cables **12**a and **12**b to prevent spontaneous movement of each cable within the guide during strenuous physical activity or in response to relatively strong gravitational forces upon the [invention's] *apparatus's 10* orientation.

As those skilled in art will recognize, guides **13**a,b must allow for the free passage of cables **12**, although under a frictional loading, so that tabs **14**a and **14**b may be grasped, pulled, and the cables moved to allow for closure of cables **12**a,b through the progressive overlapping of each cable, thereby cinching the apparatus upon the rear portion of the user's head. As will also be noted, there are areas of overlap, namely **17** and **18**a,b, that will vary in dimensional length depending upon the position of tabs **14**. As tabs **14**a and **14**b are pulled apart from one another, guides **13**a and **13**b will move toward one other and toward a virtual center point of arc **23**, thereby decreasing the dimension space **17**.

Referring to FIGS. 3 and 4, tabs **14**a,b protrude slightly away from arc **23** so that a user may reach behind each her ears and grasp the tabs **14** on each side. Since tabs **14**a,b may encounter strong torsional forces from a user's tugging, these tabs must, preferably, be securely fused to the ends of cables **12**a and **12**b, and also preferably include such resiliency that cables **12**a and **12**b would separate from temple retainers **11**a and **11**b, respectively, before tabs **14**a,b detach from the end of each cable.

While the guides **13** and the tabs **14** have been shown in generic geometries, the inventor envisions variations of ornamental geometries and/or designs to be integrated with these structures in order to enhance the attractiveness to consumers and increase sales of apparatus **10**.

Referring to FIGS. 5 and 6, it may be seen that the positioning of guides **13**a,b are positioned along cables **12**a,b to allow adjustment into a snugly fitting position.

As more easily seen in FIGS. 7 and 8, the cables **12**a,b may be positioned one above the other (i.e., juxtapositioned) and almost touching, so the guides **13** cause a more secure orientation for each cable against the wearer's head, thereby increasing stability. Further, while the inventor has appropriately sized the internal diameter of the guides **13** to restrict the movement of cables **12**a,b relative to one another, the inventor has envisioned that one cable may be affixed within guides **13**a,b so that only a cable having a tab closest to that guide may be permitted movement. For example, cable **12**a within guide **13**a may be fixed within guide **13**a, but cable **12**b may continue to slide within guide **13**a, and cable **12**b within guide **13**b may be fixed within guide **13**b. By affixing one cable within guide **13**, each guide would resist movement along the cable having a temple retainer closest to that guide, but would allow the cable having a tab closest to that guide to move freely. This type of configuration fixes the distance between the guide and its closest temple retainer, and helps to keep the positioning of the guides toward the rear area of a user's head.

Referring now to FIG. 9, it may be seen that tabs **14**a,b have been pulled such that guides **13**a,b have moved toward one another until they almost touch. This decreases the dimension **17**, until at its ultimate closed position, guides **13**a,b would contact and bear against one another. Upon guides **13** contacting one another, further pulling on tabs **14** causes lengthening of distances **18**a,b, further closing the diameter of arc **23** and tightening the apparatus **10** against the back of a wearer's head. This positioning would represent a cinched or closed position that apparatus **10** would permit on a wearer's head to snugly fit a pair of eyeglasses to the eyes. One will also notice that tabs **14**a,b may protrude slightly away from cables **12**a,b, respectively, when pulled to their tightest fitting extent. However, guides **13**a,b should be dimensioned such that tabs **14** would remain relatively close to cables **12** so as to remain out of the way of the user, and not droop down into other items that a wearer may have on her upper torso, such as jewelry or clothing.

In order for a wearer to reverse the maximum closed position, one would simply need to grasp guides **13**a and **13**b and separate them by pulling outward and around the back of the head, toward the front of the head until contacting tabs **14**. Upon contact with tabs **14** with guides **13**, the maximum expansion of apparatus **10** can be reached by continuing pressure on tabs **14**, thereby expanding dimension **17** (see FIG. 4). The aforesaid configuration and the actuation of tabs **14** relative to movement of guides **13** allows a wearer to easily and spontaneously adjust the dimensions of apparatus **10** to accomplish the rapid repositioning of eyeglasses **20**. By expanding the sizing of cables **12** relative to one



5

another, the wearer may easily detach the eyeglasses from their positions over the ears and rest the eyeglasses upon the upper front vestment of the wearer's clothes. This allows a wearer to remove eyeglasses quickly for activities with the unaided eye in situations where the optical properties of the eyeglasses are not appropriate for a wearer's environment. For example, a near-sighted individual may remove glasses after proper actuation of guides **13** and tabs **14** to allow the eyeglasses to rest on their upper chest vestment while the wearer does un-aided eye, close-up work. For another example, a nearsighted fisherman may wish to tie a knot onto a hook or other type of fishing tackle without his or her eyeglasses, and then when finished may wish to restore the eyeglasses, snugly against his face. This can easily be accomplished with the pulling of tabs **14** to secure the eyeglasses upon the rear of his head when wishing to resume vigorous fishing activities and to utilize his glasses to focus on objects farther away. Other anticipated actuations of the apparatus would be when a fisherman on a boat needs to go below deck to pursue navigation activities and the tinting properties of the eyeglasses are too extreme to permit the proper viewing of navigational charts in a darkened environment below a boat's deck. The apparatus **10** could be loosened for studying a chart, and then restored after returning to a sun-lit environment in accordance with the procedure described above. Hence, *embodiments* of the invention [allows] allow for rapid removal and repeated adjustment of eyeglasses and promotes their greater utility.

FIG. **10** depicts an embodiment with one guide **22** with the two cables passing through the guide **22**. This embodiment also shows cable **12a** being secured to a tab **24** and cable **12b** passing slideably through a tunnel **25** shown in the inset on in FIG. **10**. The tab **24** on the other side of FIG. **10**, not shown, would be reversed, with cable **12b** being secured to the tab **24** and cable **12a** passing slideably through a tunnel **25**. FIG. **11** is similar to FIG. **10**, but shows an embodiment of the invention [without a guide. The] *in which the tabs act as a guiding means. The tunnels in the tabs* **24** in FIG. **11**, the embodiment without the guide, keep the cables connected to one another slideably *as the tunnel(s) in the separate guide member(s) in other embodiments do.* The inset on FIG. **10** is equally applicable to FIG. **11**.

In the final three FIGS. the tightened and loosened positions of [the] *three embodiments* of invention with the suspended arc above the wearer's neck, shoulders and garments are shown [in three embodiments]: with two guides and tabs which do not contain a tunnel for one of the cables—**12A,B**; with one guide and tabs with a tunnel for one of the cables—**13A,B**; and without a *separate* guide member but with each tab containing a tunnel for one of the cables *and acting as a guide*—**14A,B**. The number of guides can be selected independently of whether one of the cables passes through a tunnel in the tab. However, if there is not at least one *separate* guide then each tab must have a tunnel through which one of the cables passes through slideably *to serve as a guiding means*, in order to keep the device together.

While the invention is shown in several forms, it will be obvious to those skilled in the art that it is not so limited, but is susceptible of various changes and modifications without departing from the spirit thereof.

Having set forth the nature of the invention, what is claimed is:

1. An adjustable eyewear retention device, comprising:
  - a. two cables,

6

- b. two temple retainers, each having an opening for receiving the end of an eyeglass temple and each secured to a first end of one of the two cables,
- c. two tabs, each of which is secured to a second end of one of the two cables, and
- d. at least one guide through which the two cables pass slideably;
- e. such that when each said opening is attached to the end of an eyeglass temple and the eyeglasses are worn over the ears of a wearer, the two cables partially overlap and form an arc suspended above the wearer's neck, shoulders or garments, and such that moving the tabs adjusts the length of the arc.

2. The invention as in claim **1**, further comprising a tunnel in each of the two tabs which allows one of the cables to pass through slideably.

3. The invention as in claim **2**, further comprising deleting the at least one guide through which the two cables pass slideably.

4. The invention as in claim **1**, in which the at least one guide allows the two cables to move by frictional loading.

5. The invention as in claim **1**, [further comprising] *wherein* pulling the tabs away from the at least one guide decreases the length of the arc, and pushing the tabs toward the at least one guide increases the length of the arc.

6. The invention in claim **1**, further comprising at least [two guides] *a second guide* through which the two cables pass slideably, there being a dimension between the [at least two] guides along the cables and a dimension between each said guide and one of the tabs along one of the cables, and wherein pulling either of the two tabs towards the ears causes the dimension between the [at least two] guides to decrease and pushing either of the two tabs away from the ears causes the dimension between the [at least two] guides to increase.

7. The invention in claim **1**, [further comprising] *wherein* the at least one guide [being] *is* positioned such that the two cables are in close proximity to one another and partially overlap one another, and each said tab extends outward away from the at least one guide.

8. The invention in claim **1**, [further comprising] *wherein* the at least one guide [being] *is* arcuate in shape.

9. The invention in claim **1**, [further comprising] *wherein* the two cables [being composed of] *comprise a* material selected from the group of monofilament fishing line, twisted metal cable, and plastic tubing.

10. The invention as recited in claim **1**, [further comprising] *wherein* one of the two cables [being] *is* fixed inside [each said] *the at least one* guide.

11. An adjustable eyewear retention device, comprising:

- a. two cables,
- b. means for retaining the temples of a pair of eyeglasses to the ends of said cables,
- c. means for grasping the terminus of each said cable at an end distal from said retention means,
- d. means for guiding said two cables such that each cable is positioned close to one another, and
- e. wherein the two cables form an arc suspended above the wearer's neck, shoulders or garments, and wherein the two cables are movable through said guiding means responsive to moving each grasping means to allow adjustment of the arc to or from the head of a user.

12. The invention as in claim **11**, in which the guiding means allow the two cables to move by frictional loading.

13. The invention in claim **11**, [further comprising] *wherein* the two cables [being composed of] *comprise*

7

material selected from the group of monofilament fishing line, twisted metal cable, and plastic tubing.

\* \* \* \* \*

8

UNITED STATES PATENT AND TRADEMARK OFFICE  
**CERTIFICATE OF CORRECTION**

PATENT NO. : RE47,724 E  
APPLICATION NO. : 13/660706  
DATED : November 12, 2019  
INVENTOR(S) : Williams

Page 1 of 1

It is certified that error appears in the above-identified patent and that said Letters Patent is hereby corrected as shown below:

In the Claims

At Column 6, Lines 18-20, please replace Claim 3 in its entirety with the following Claim 3:  
--3. The invention as in claim 2, [further comprising deleting] *wherein* the at least one guide [through which the two cables pass slideably] *is the tunnel in each of the two tabs.--*

Signed and Sealed this  
Fourth Day of February, 2020

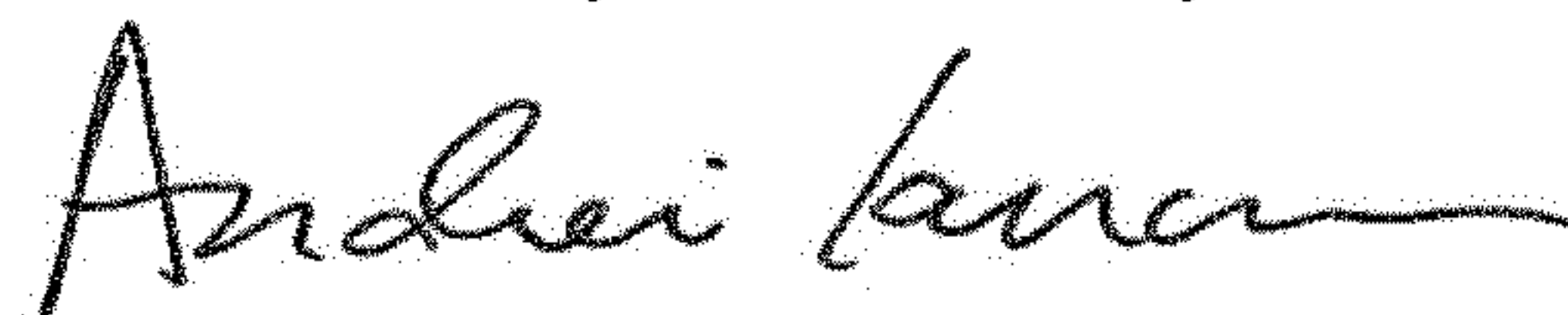

Andrei Iancu  
Director of the United States Patent and Trademark Office