



US00RE47702E

(19) **United States**
(12) **Reissued Patent**
Verschoor et al.

(10) **Patent Number: US RE47,702 E**
(45) **Date of Reissued Patent: Nov. 5, 2019**

(54) **DISPLAY DEVICE WITH FLEXIBLE DISPLAY**

(71) Applicant: **Samsung Electronics Co., Ltd.**,
Suwon-si, Gyeonggi-do (KR)

(72) Inventors: **Volker Barnhart Verschoor**,
Eindhoven (NL); **Johannes Cornelis**
Adriaan Hamers, Eindhoven (NL);
Hendrik Visser, Eindhoven (NL);
Michael Johannes Anna Maria
Walters, Eindhoven (NL)

(73) Assignee: **Samsung Electronics Co., Ltd.**,
Suwon-si (KR)

(21) Appl. No.: **14/965,207**

(22) Filed: **Dec. 10, 2015**

Related U.S. Patent Documents

Reissue of:

(64) Patent No.: **8,605,421**
Issued: **Dec. 10, 2013**
Appl. No.: **13/211,561**
Filed: **Aug. 17, 2011**

(51) **Int. Cl.**
G06F 1/16 (2006.01)
H05K 5/00 (2006.01)
H04M 1/00 (2006.01)
H05K 7/00 (2006.01)

(52) **U.S. Cl.**
CPC **G06F 1/1652** (2013.01)

(58) **Field of Classification Search**
CPC .. H05K 5/00; H05K 7/00; G06K 1/16; H04M
1/00
USPC 361/679.3, 679.21, 679.26, 679.55,
361/679.56; 455/575.1, 575.4
See application file for complete search history.

(56) **References Cited**

U.S. PATENT DOCUMENTS

6,016,176 A * 1/2000 Kim et al. 349/84
6,377,324 B1 * 4/2002 Katsura 349/58
(Continued)

FOREIGN PATENT DOCUMENTS

CN 1744803 A 3/2006
CN 1960612 A 5/2007
(Continued)

OTHER PUBLICATIONS

Netherlands Patent Office, Search Report, Patent Application Serial
No. NL 2007427, Apr. 26, 2012, Netherlands.

Primary Examiner — Linh M Nguyen

(74) *Attorney, Agent, or Firm* — Jefferson IP Law, LLP

(57) **ABSTRACT**

The invention relates to a display device comprising a device body with upper and lower body sides and having at least one surface support part for supporting the body on a surface, and a continuous flexible display. A support frame is configured to support at least a part of the flexible display, at least a portion of the support frame is connected with the device body and is movable with respect to the device body between a closed configuration for fixing the flexible display in a storage position and an open configuration for fixing the flexible display in an open position. There is at least one surface support part for supporting the support frame on a surface. In the open configuration the surface support parts of the support frame and of the lower body side are positioned in one plane, enabling a supporting of the surface support parts on a surface for a stable user interaction with the device in the open position of the display.

7 Claims, 5 Drawing Sheets

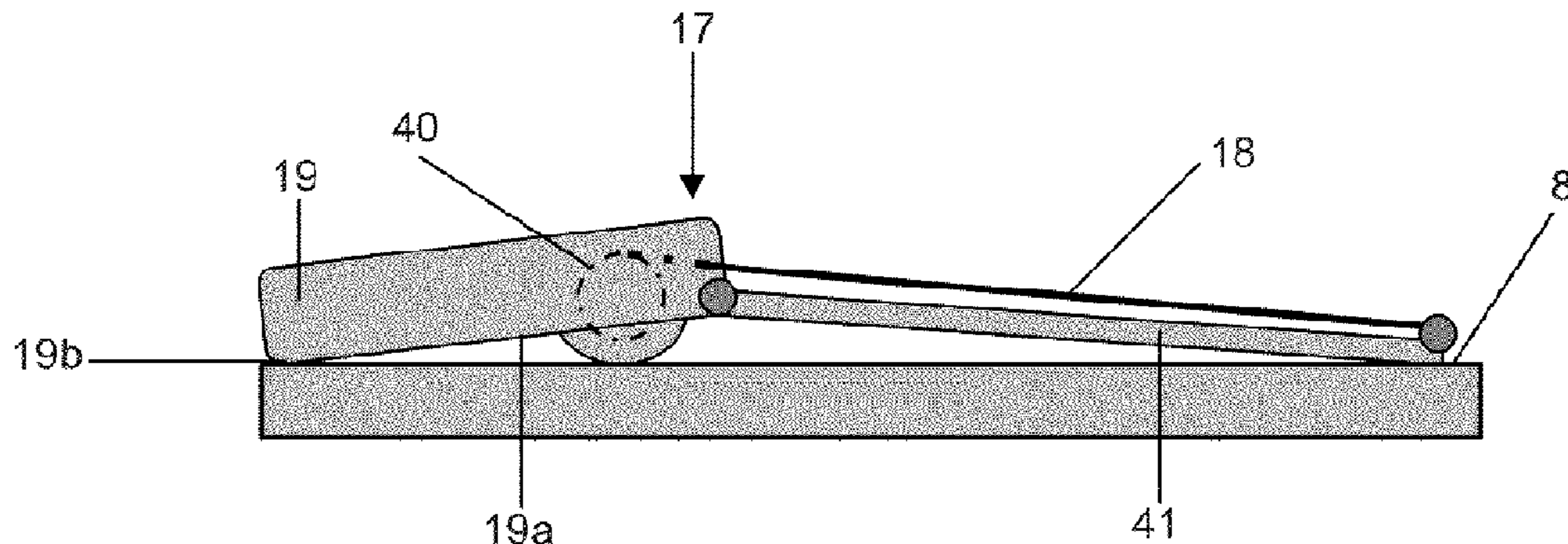

US RE47,702 E

(56)

References Cited

U.S. PATENT DOCUMENTS

6,577,496	B1 *	6/2003	Gioscia et al.	G06F 1/1616	
				345/156	
7,440,265	B2 *	10/2008	Ou Yang	361/679.27	
7,558,057	B1 *	7/2009	Naksen et al.	361/679.56	
7,667,962	B2 *	2/2010	Mullen	361/679.56	
8,035,577	B2 *	10/2011	Lafarre et al.	345/55	
8,369,075	B2 *	2/2013	Huang	361/679.21	
8,385,055	B2 *	2/2013	Kao et al.	361/679.06	
8,466,851	B2	6/2013	Huitema et al.		
8,477,464	B2 *	7/2013	Visser	G06F 1/1613	
				340/815.83	
8,493,726	B2	7/2013	Visser et al.		
8,564,551	B2 *	10/2013	Park	G06F 3/03545	
				345/173	
8,787,016	B2 *	7/2014	Rothkopf	H04M 1/0216	
				361/679.55	
8,803,816	B2 *	8/2014	Kilpatrick, II	G06F 1/1616	
				345/173	
8,804,324	B2 *	8/2014	Bohn	G06F 1/1616	
				345/1.1	
9,107,287	B2	8/2015	Ryu		
9,176,535	B2 *	11/2015	Bohn	G06F 1/1641	
9,557,588	B2 *	1/2017	Huitema	G02F 1/133305	
2006/0038745	A1	2/2006	Naksen et al.		
2006/0050169	A1	3/2006	Misawa		
2006/0061555	A1	3/2006	Mullen		
2006/0146488	A1 *	7/2006	Kimmel	361/681	
2007/0097014	A1	5/2007	Solomon et al.		
2007/0241002	A1	10/2007	Wu et al.		
2008/0204367	A1	8/2008	Lafarre et al.		
2009/0262079	A1	10/2009	Bury et al.		
2010/0064564	A1	3/2010	Bemelmans et al.		
2010/0164837	A1 *	7/2010	Kao et al.	345/1.3	
2010/0164973	A1	7/2010	Huitema et al.		

2010/0171683	A1	7/2010	Huitema et al.		
2010/0182738	A1	7/2010	Visser et al.		
2010/0194785	A1	8/2010	Huitema et al.		
2010/0208417	A1	8/2010	Visser et al.		
2010/0246113	A1	9/2010	Visser et al.		
2012/0033353	A1	2/2012	Huang		
2012/0314399	A1 *	12/2012	Bohn	G06F 1/1616	
				362/97.1	
2013/0010405	A1 *	1/2013	Rothkopf	H04M 1/0216	
				361/679.01	
2013/0141847	A1	6/2013	Ryu		
2015/0241927	A1	8/2015	Ryu		

FOREIGN PATENT DOCUMENTS

CN	101213500	A	7/2008
CN	101681038	A	3/2010
CN	101681074	A	3/2010
CN	101689065	A	3/2010
CN	101689066	A	3/2010
CN	101772943	A	7/2010
JP	2010-99122	A	5/2010
JP	2010-181899	A	8/2010
JP	3164598	U	11/2010
JP	2011-112891	A	6/2011
TW	M369468	U	11/2009
WO	2006/038171	A1	4/2006
WO	WO 2006/038171		4/2006
WO	2008/054206	A2	5/2008
WO	WO 2008/054206		5/2008
WO	2008/151686	A1	12/2008
WO	2008/153402	A2	12/2008
WO	2009/148313	A1	12/2009
WO	2010/019466	A1	2/2010
WO	2010/059018	A2	5/2010
WO	2011/067921	A1	6/2011

* cited by examiner

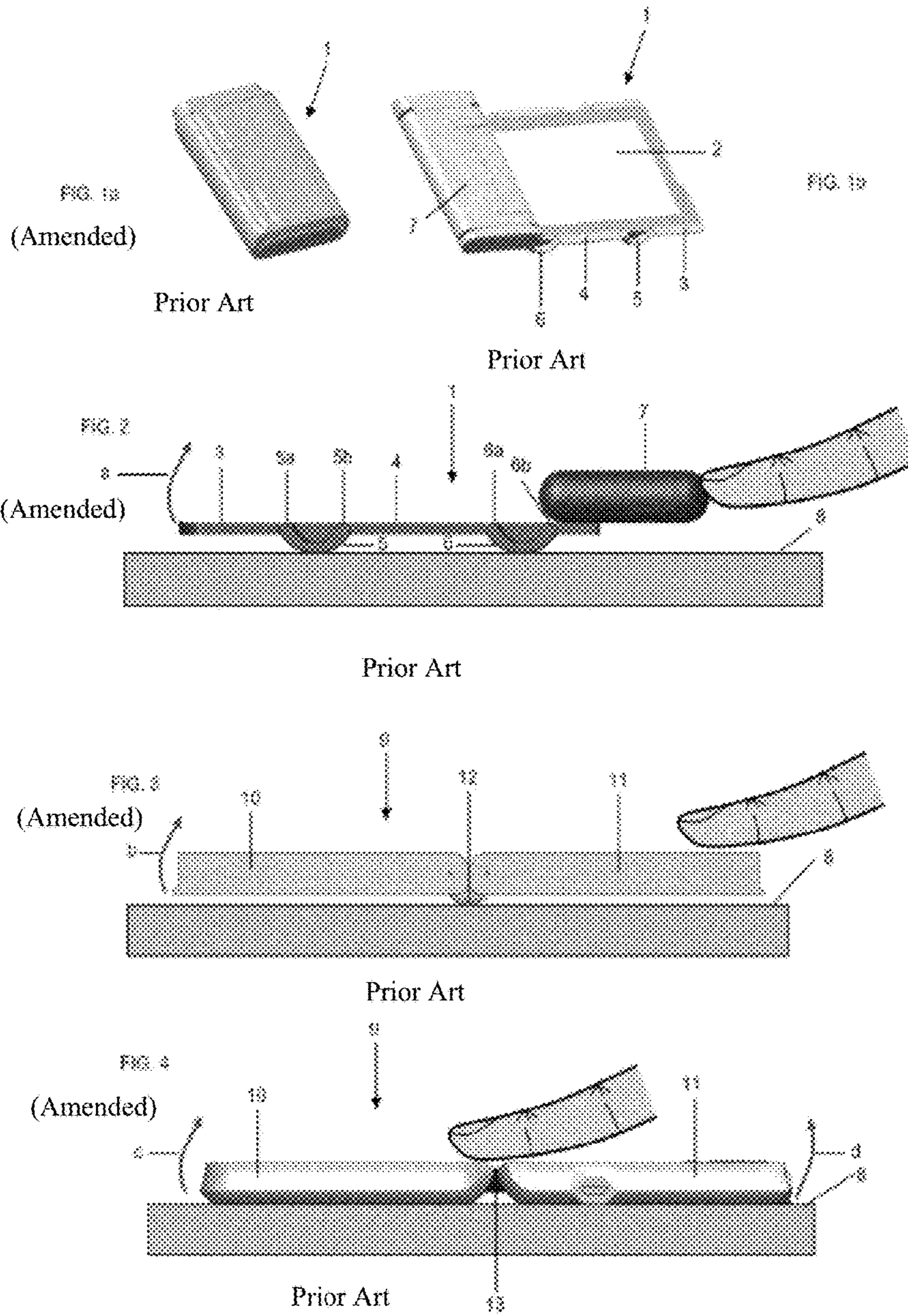

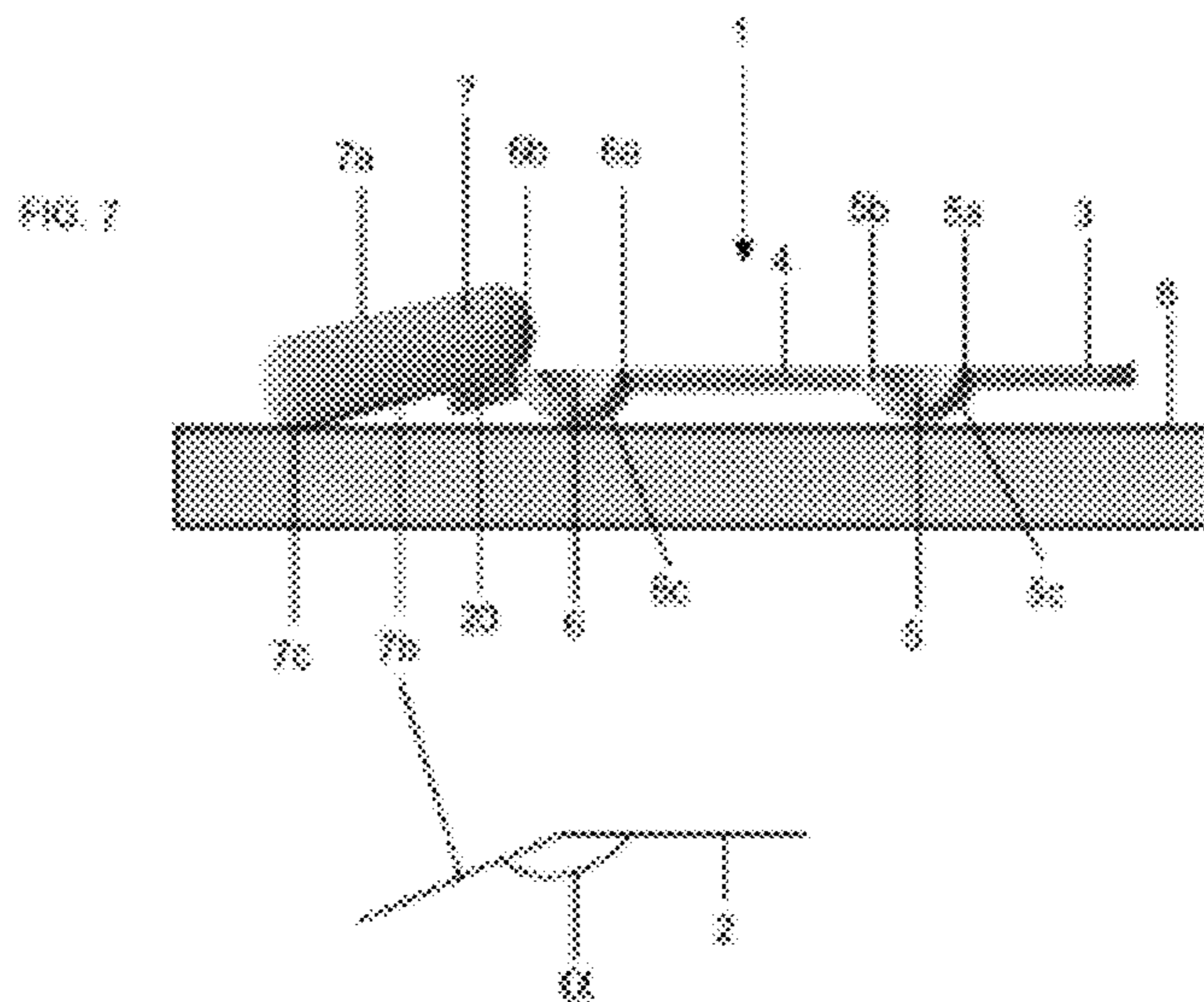
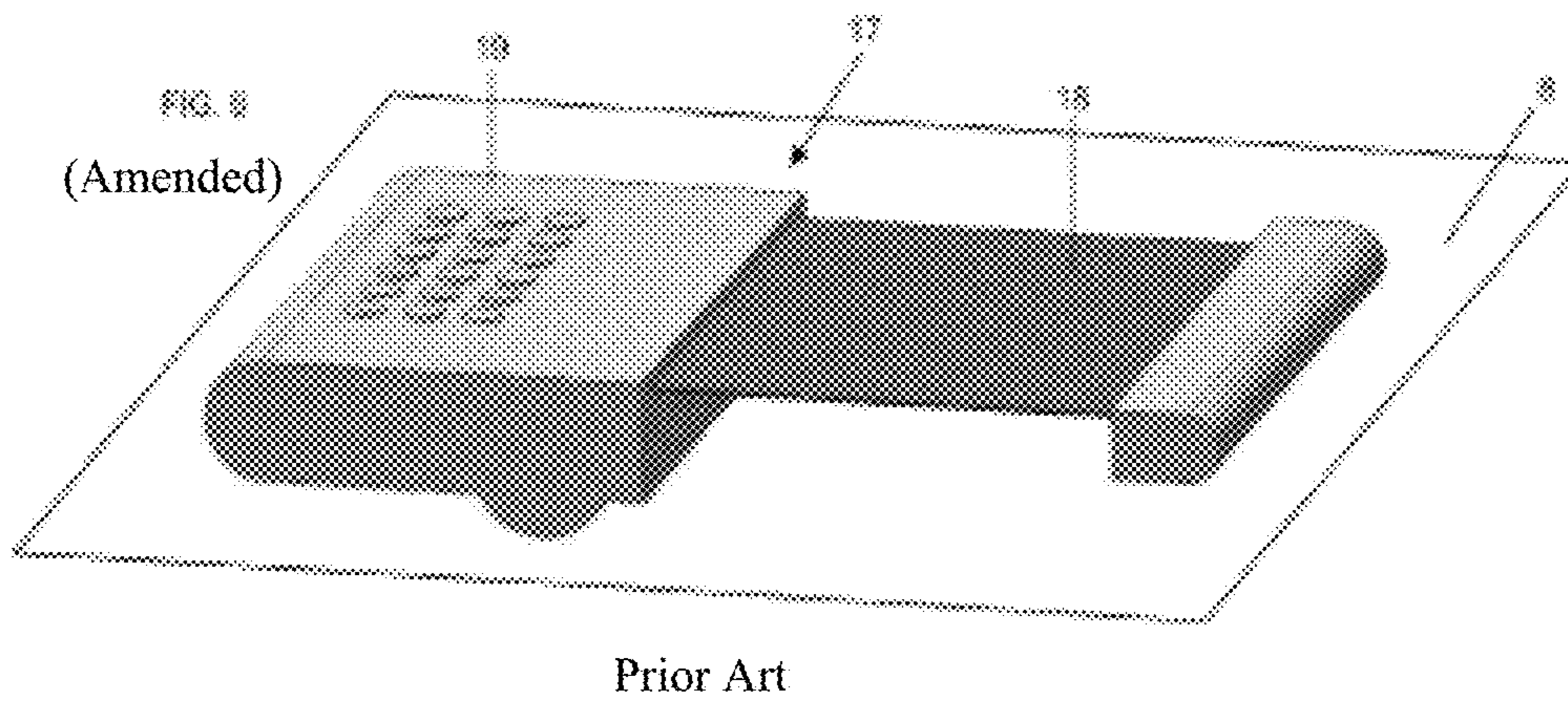
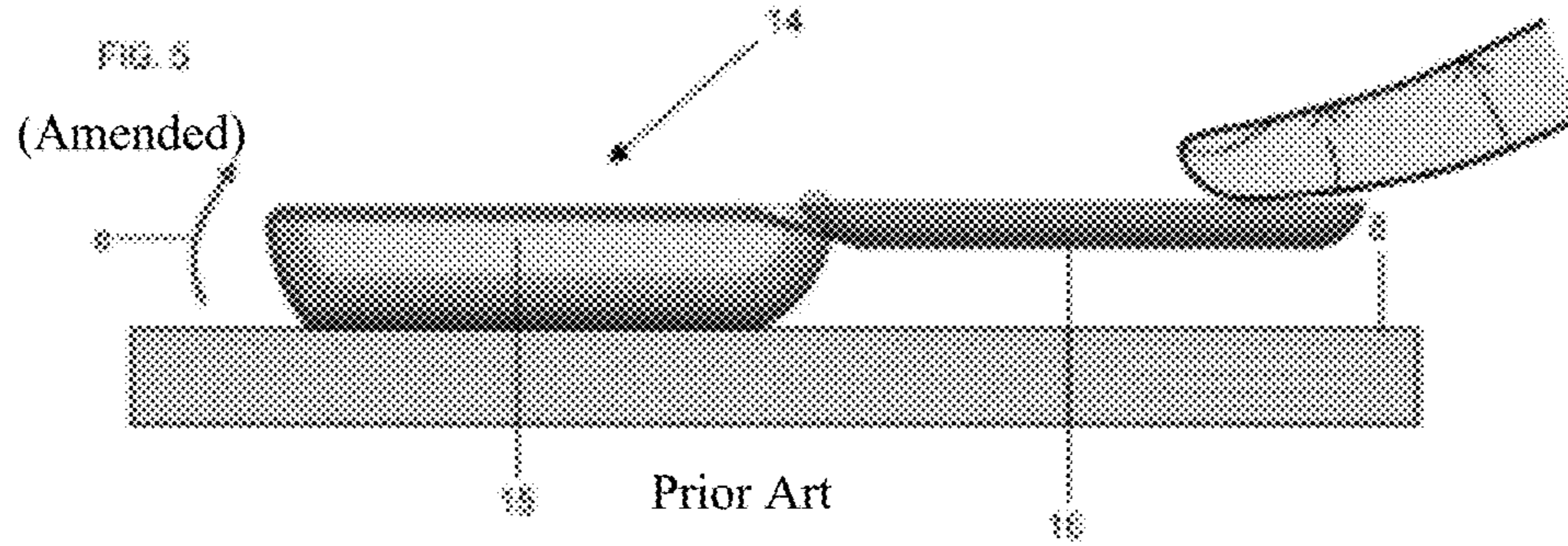

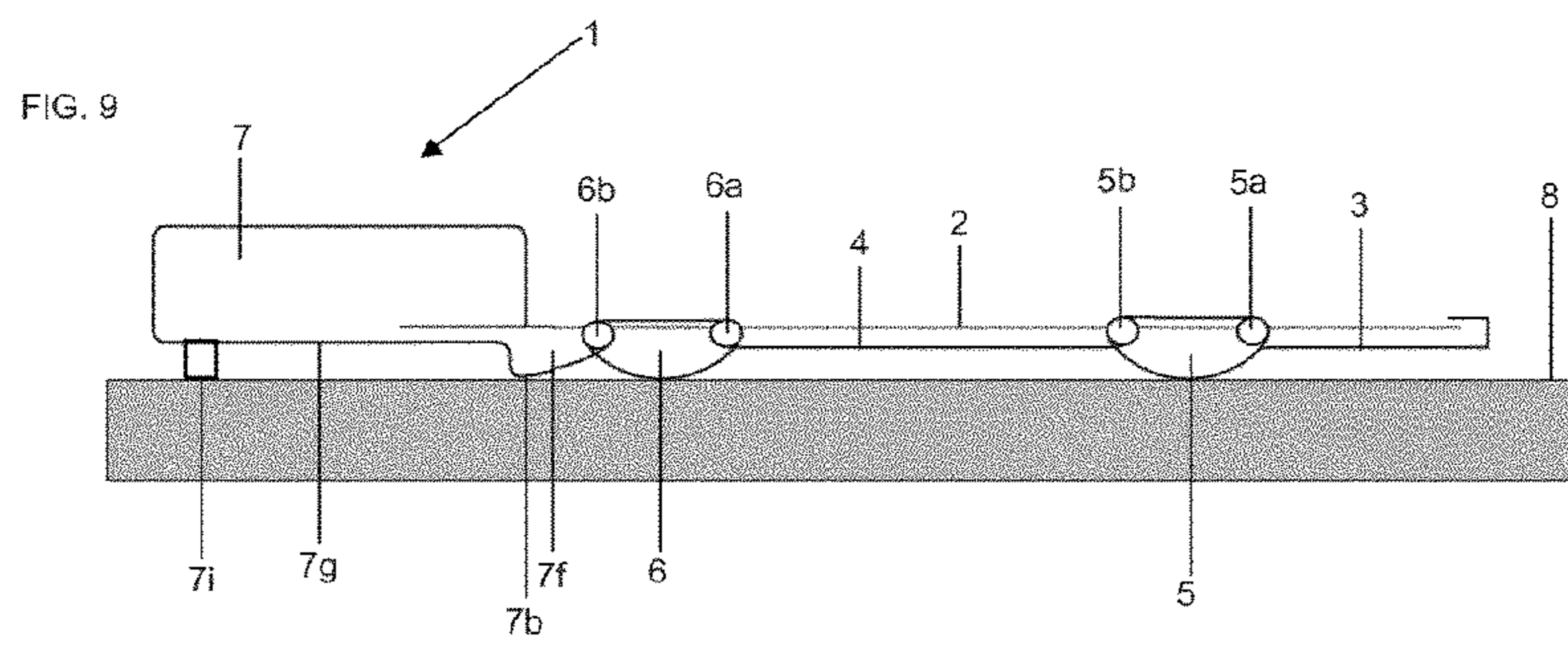
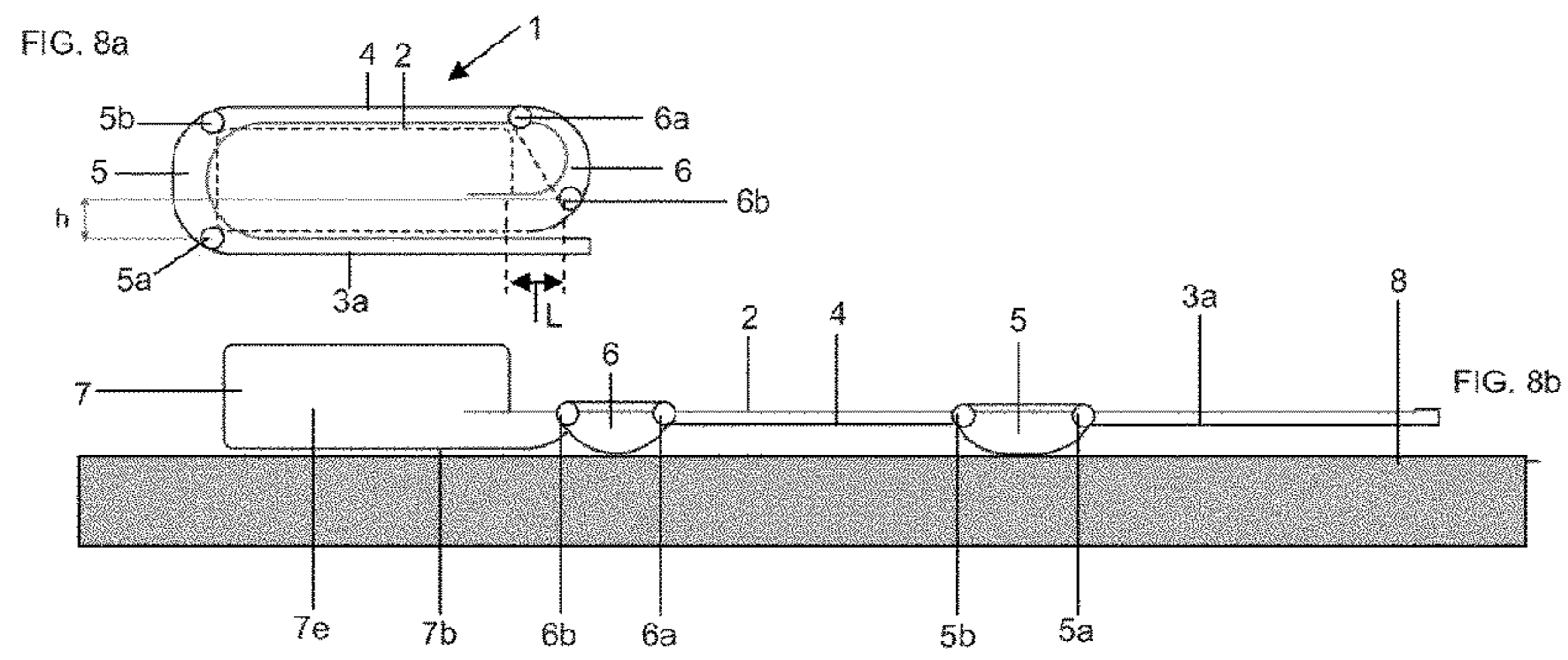

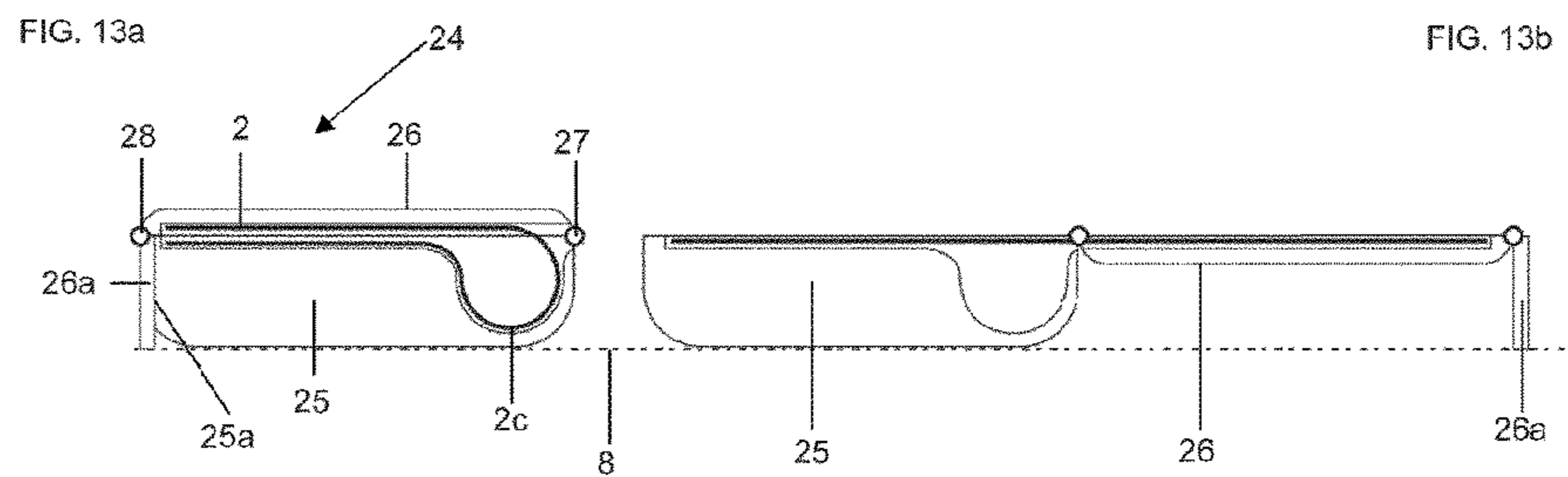
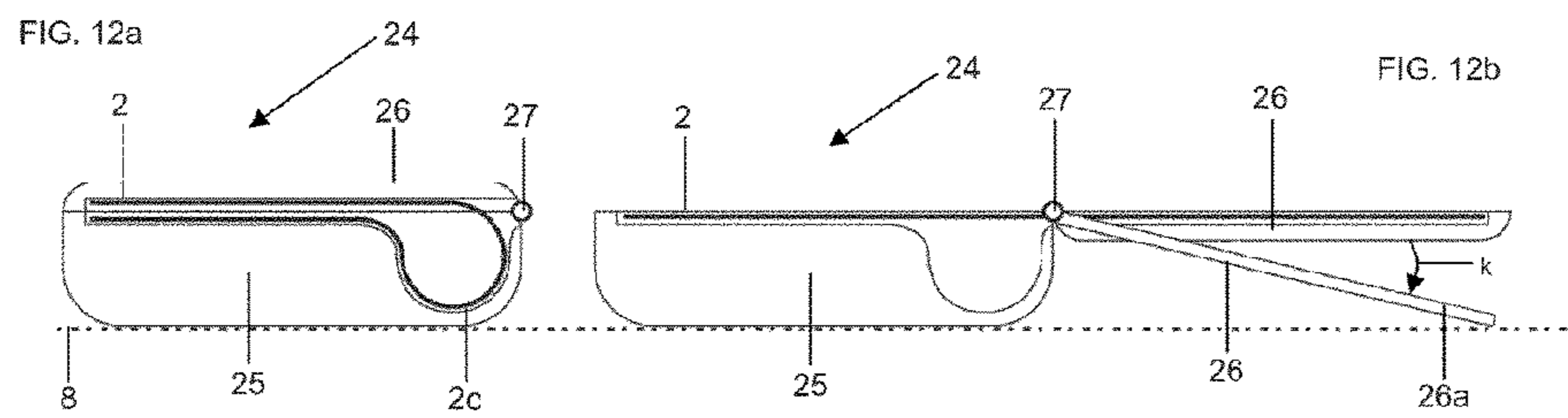
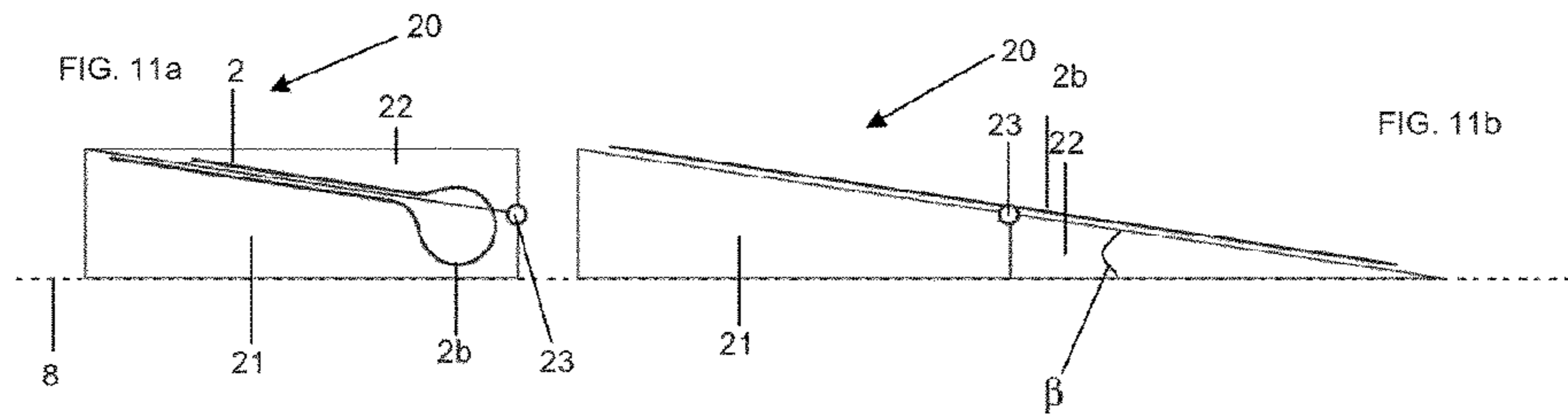
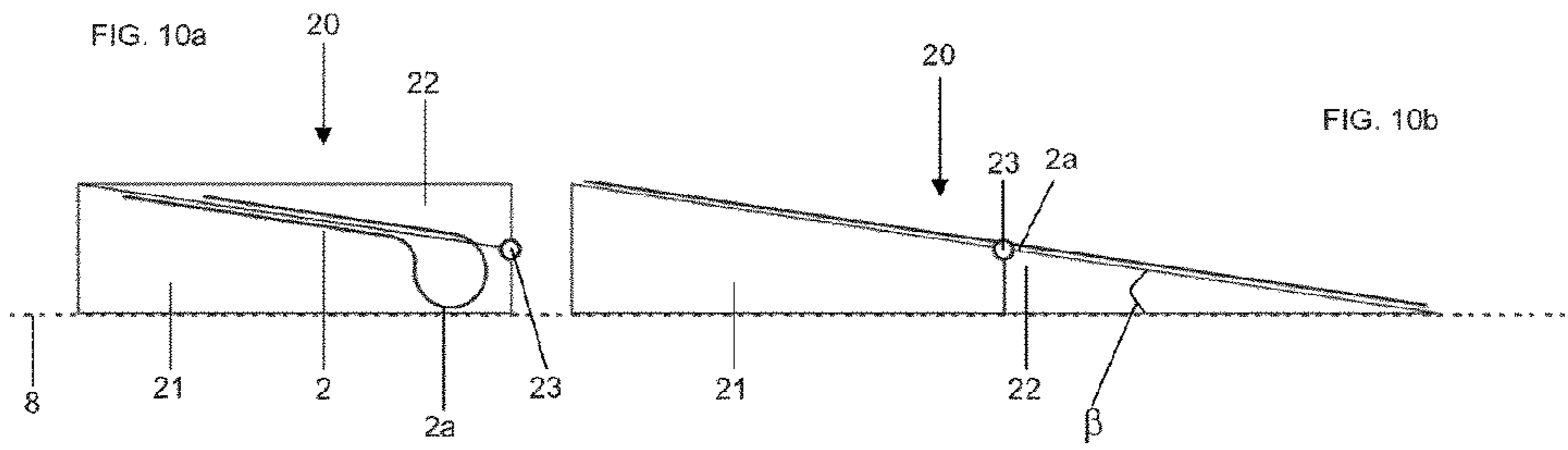

FIG. 14a

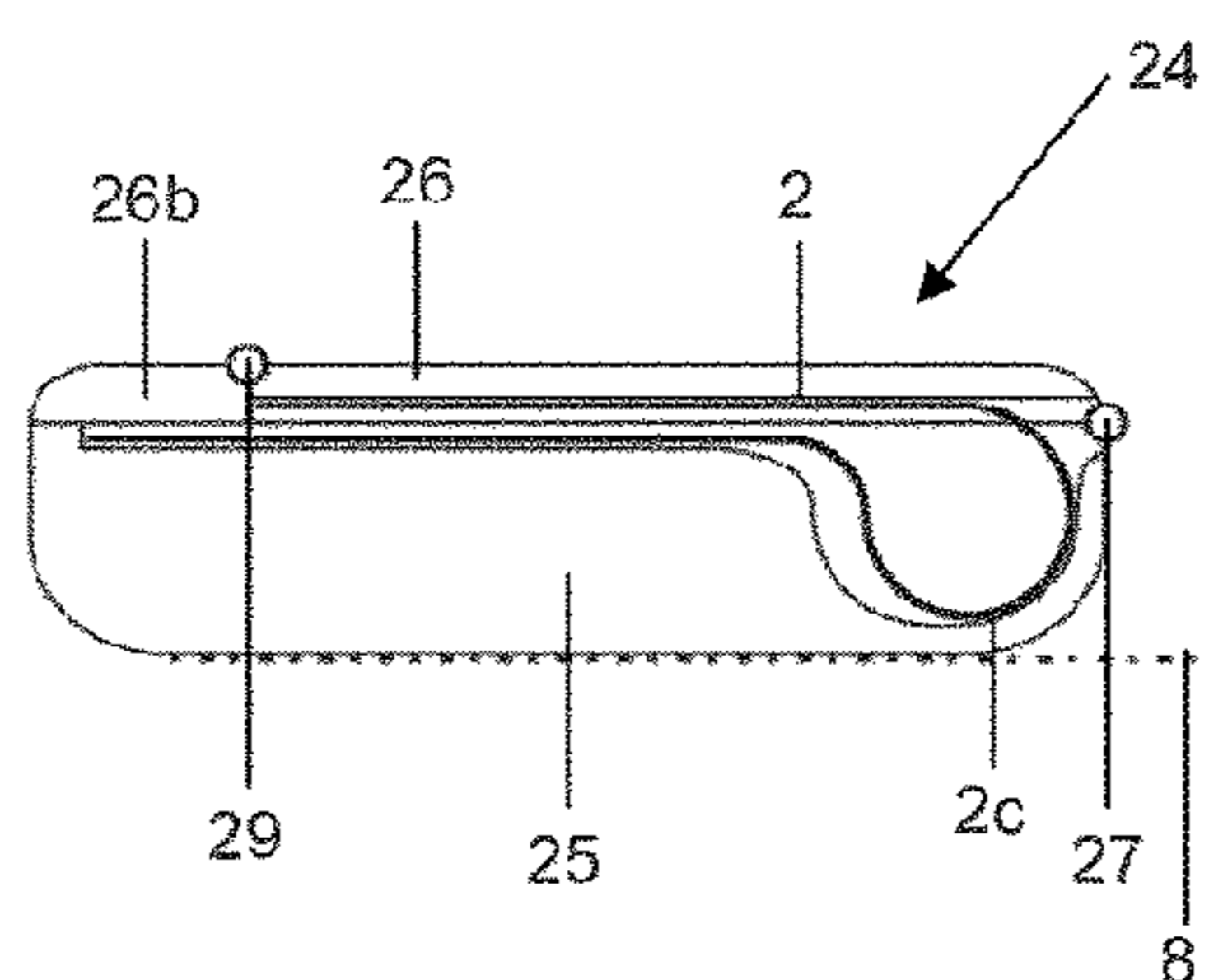

FIG. 14b

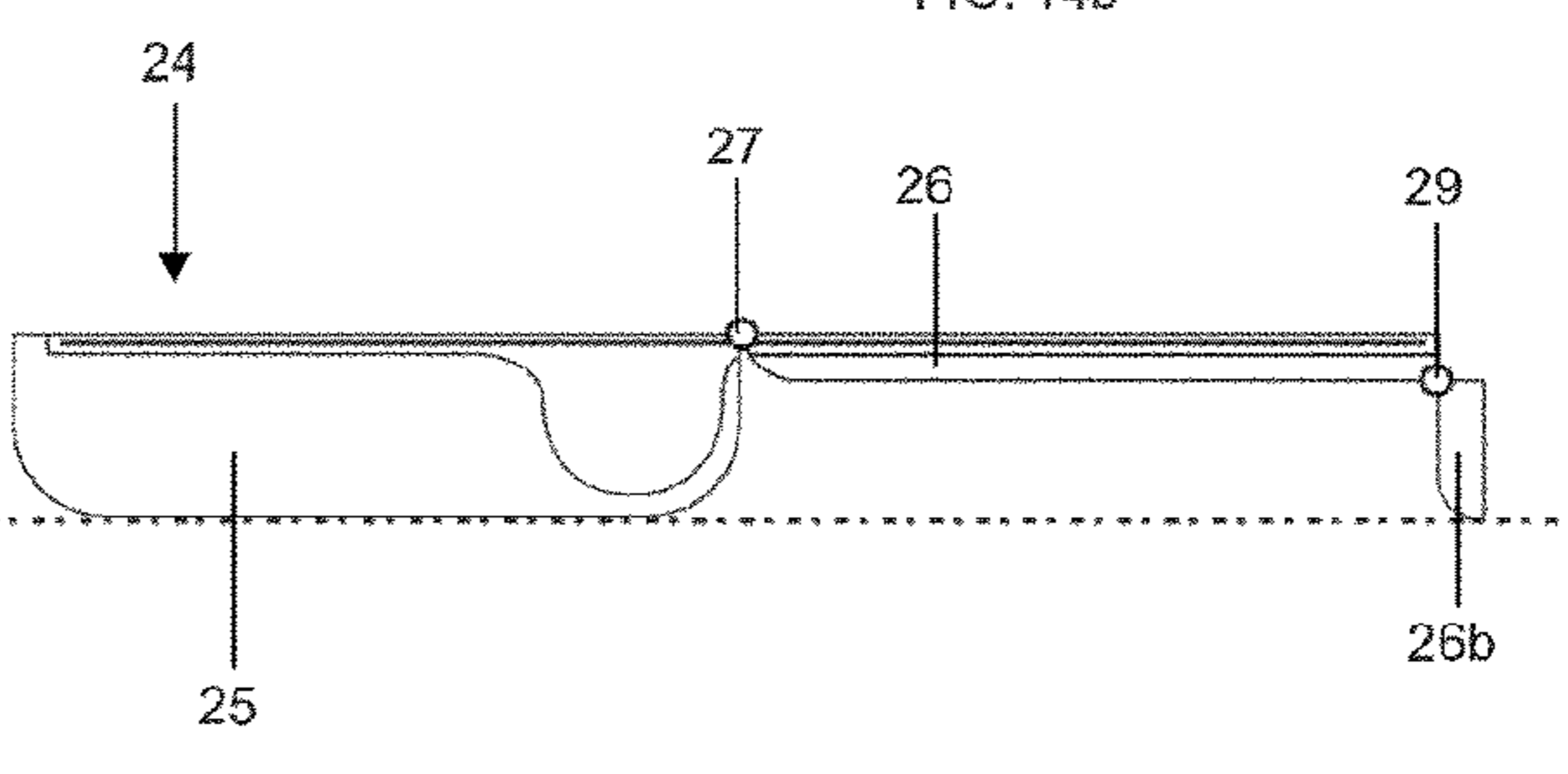

FIG. 15a

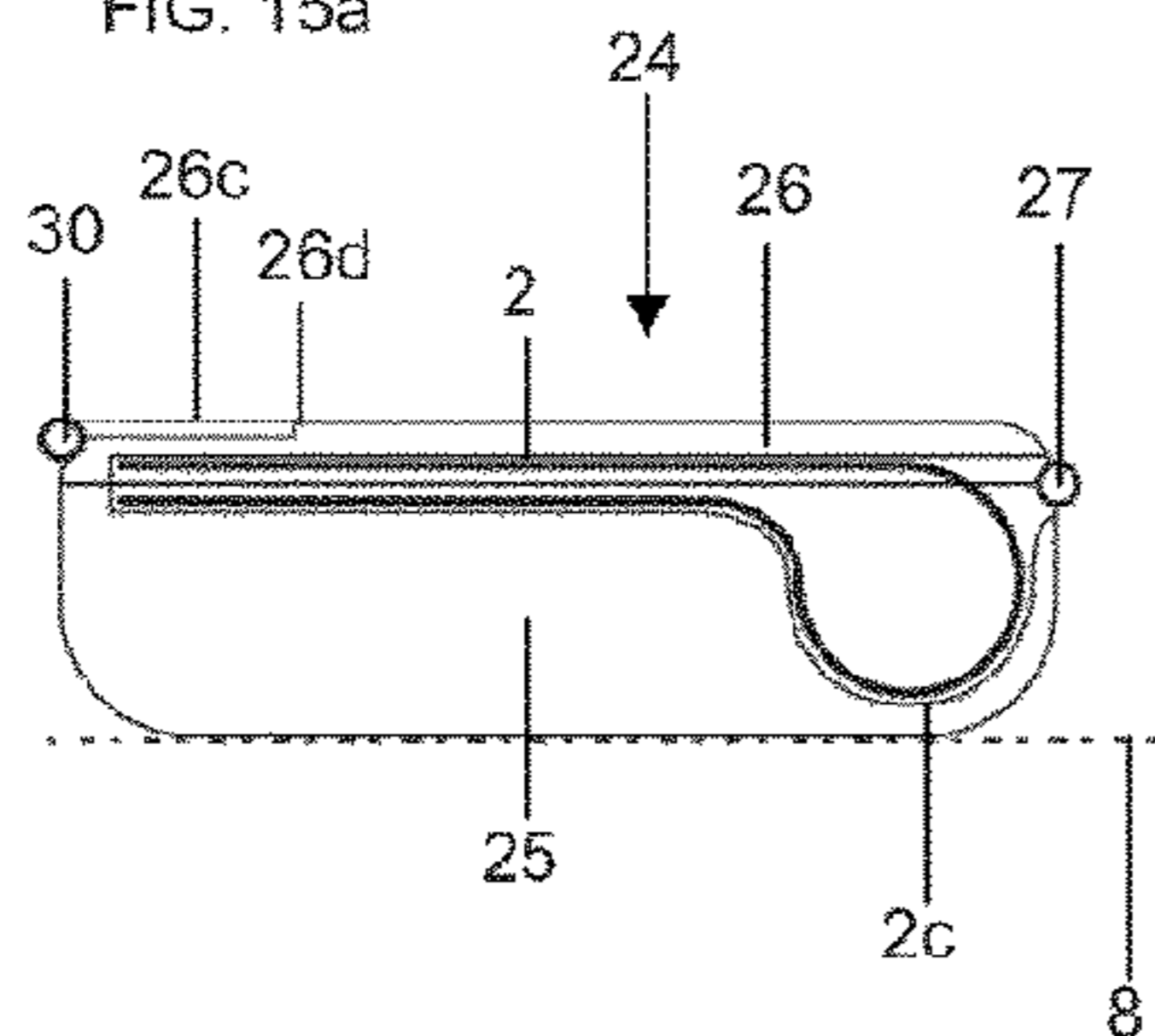

FIG. 15b

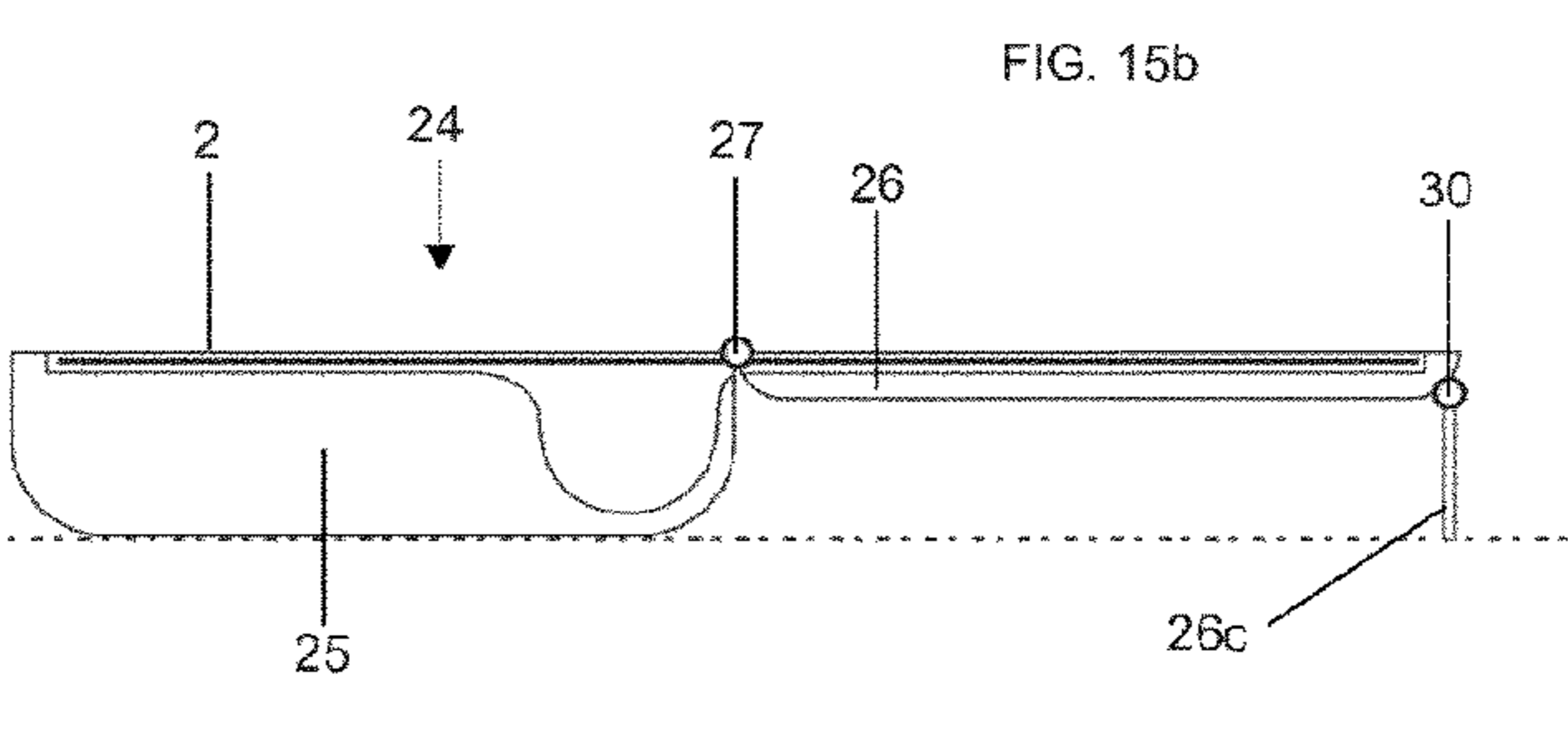

FIG. 16a

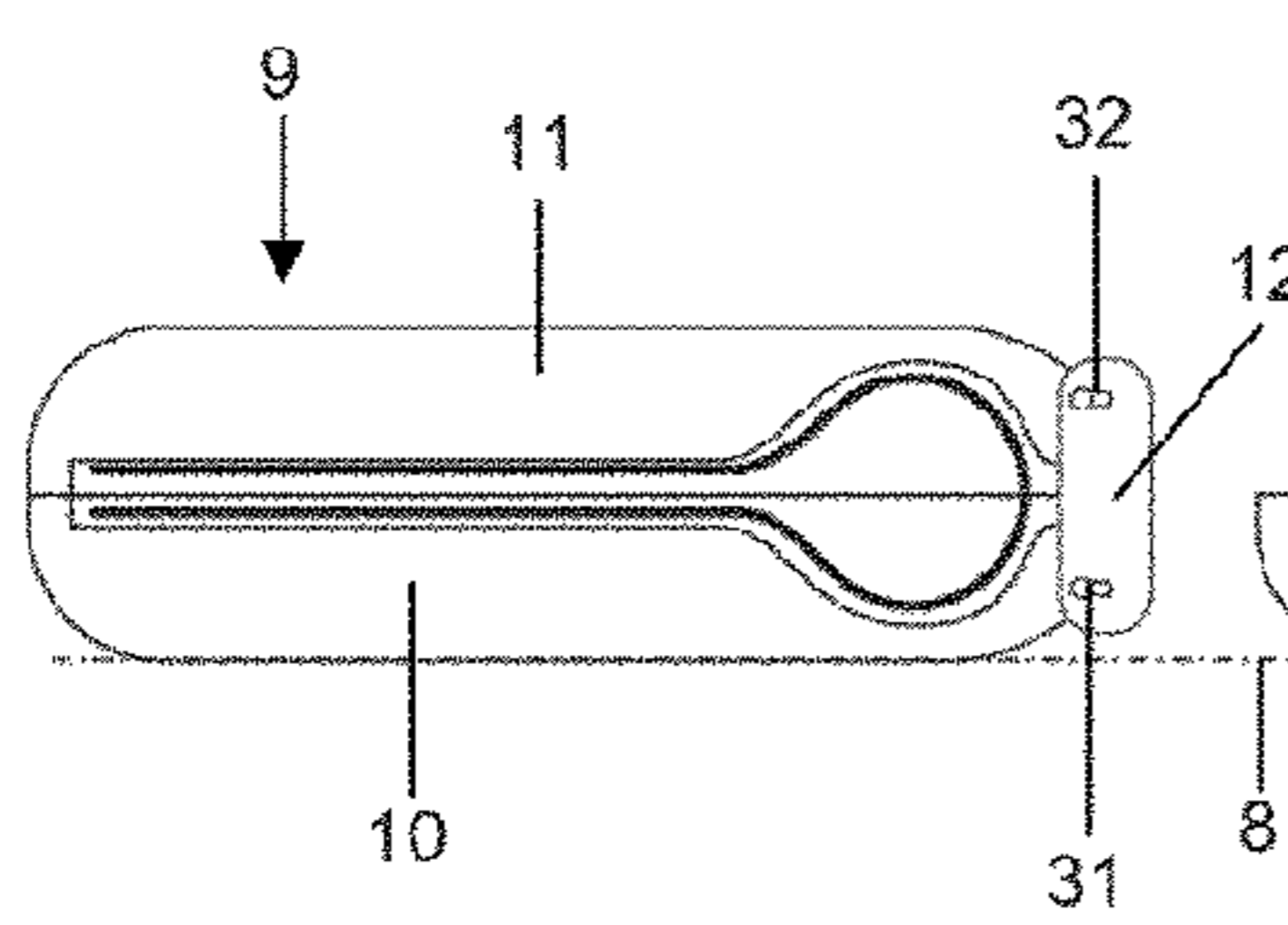

FIG. 16b

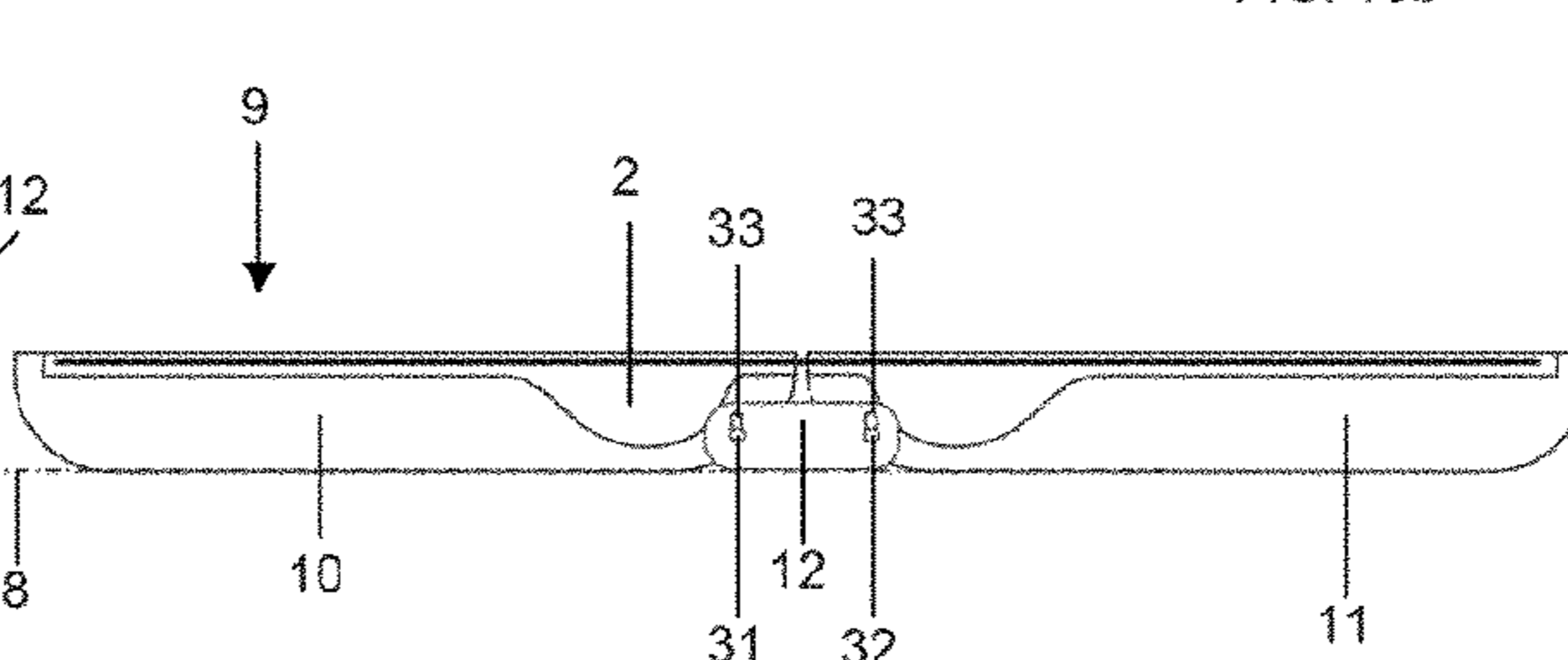
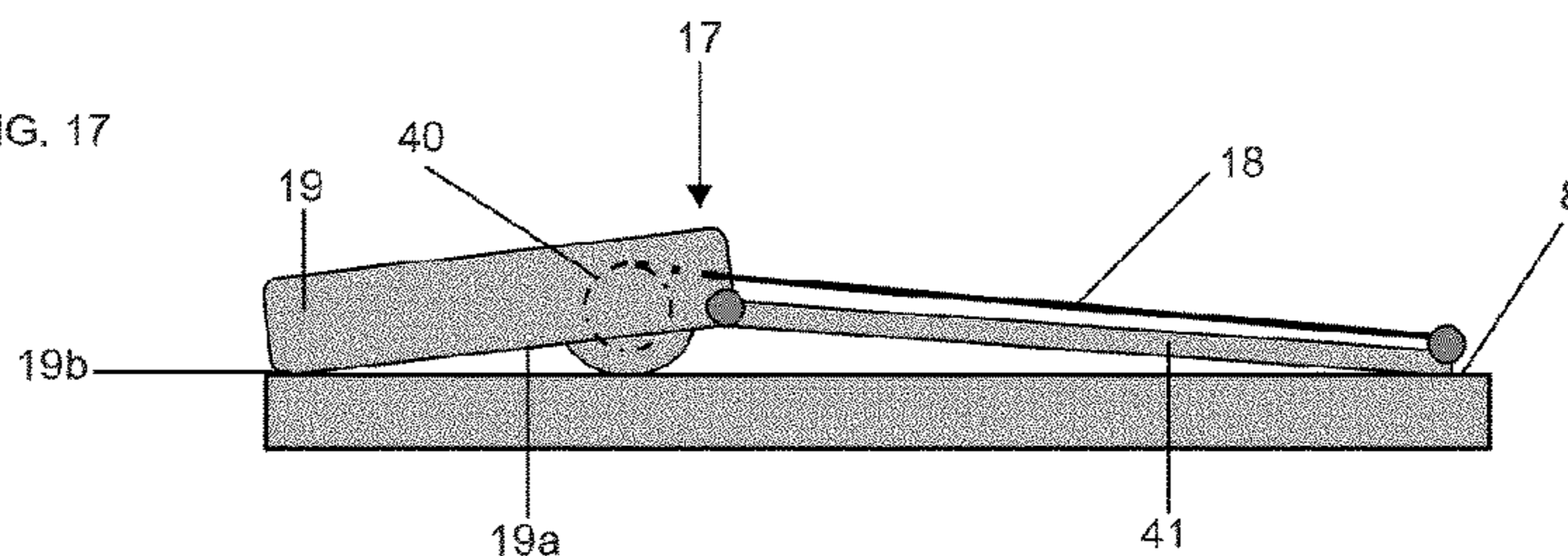

FIG. 17



DISPLAY DEVICE WITH FLEXIBLE DISPLAY

Matter enclosed in heavy brackets [] appears in the original patent but forms no part of this reissue specification; matter printed in italics indicates the additions made by reissue; a claim printed with strikethrough indicates that the claim was canceled, disclaimed, or held invalid by a prior post-patent action or proceeding.

TECHNICAL FIELD

The present invention generally relates to display devices with a flexible display. The present invention specifically relates to display devices with a flexible display, a supporting frame and a device body.

BACKGROUND

Mobile display devices, such as mobile phones or e-readers, which make use of flexible displays have in their storage position a compact state, for instance for transportation, previewing or phone calls. In the open position they are in a reading/viewing state with the flexible display in extended position supported by a support frame.

A display device that makes use of these two states will have a specific shape that is different from mobile products that do not use flexible displays. This specific shape can make the user interaction with the device mechanically instable or can make it difficult to handle by a user.

A number of product concepts have been developed for devices with flexible displays. The most important concepts are the 'wrap', the 'book' and the 'roll'. An example of a 'wrap' concept is shown in WO 2008/054206 A2, of a 'roll' concept in WO 2006/038171 A1.

One of the problems in user interaction with a mobile e-reader in the use of a prior art "wrap"-type e-reader, as shown in FIG. 1, is shown in FIG. 2. When such a device in the open position is put on a table, it is unstable and will rock or wiggle when a user is interacting with the device, e.g. touching buttons on the device to switch pages. The same problem will occur when the user holds the device in hand while pushing the buttons or touching the display in case it is a touch sensitive display.

In a 'book' type e-reader as shown in FIG. 3 for example provided with a dual hinge variant, the bridge between the book halves can be very big, and therefore stick out below the book halves in open position. This can result in the book wobbling when interacted with, while on a table.

On the other hand a problem as shown in FIG. 4 can also occur when the bridge between the book halves is very thin. Depending on the desired shape of the product if the user presses on the central part of the open book device the book halves can flip upwards.

A special form of the book device is the so-called asymmetric book as shown in FIG. 5. In this case one half of the book is thicker than the other. This has some advantages such as weight and volume distribution and touch support. However the wiggle problem is of course even larger in this concept.

Another type of e-reader with a flexible display is a "roll-type" e-reader as shown in FIG. 6. When such a device is put on a table or held by hand, it can also be unstable, similar to the wrap-type device.

It is an object of the invention to improve the physical user interaction with a mobile display device provided with a flexible display.

The present invention is directed toward overcoming one or more of the problems discussed above.

SUMMARY OF THE EMBODIMENTS

According to the invention the display device comprises a device body with upper and lower body sides and has at least one surface support part for supporting the body on a surface, a continuous flexible display, a support frame configured to support at least a part of the flexible display, at least a portion of the support frame being connected with the device body and being movable with respect to the device body between a closed configuration for fixing the flexible display in a storage position and an open configuration for fixing the flexible display in an open position, and having at least one surface support part for supporting the support frame on a surface, wherein in the open configuration the at least one surface support part of the support frame and the surface support part of the lower body side are positioned in one plane, enabling a supporting of the surface support parts of the support frame and of the device body on a surface for a stable user interaction with the device in the open position of the display.

In accordance with the invention, by positioning in the open position in one common plane the surface support parts of the device body and the support frame that supports the flexible display, the freedom of movement of the device is limited during user interaction with the display device.

By doing this the device is better supported when placed on a surface such as a table. The user can interact with buttons on the device body, without creating unwanted movements of the flexible display device.

According to one embodiment of the invention in the open configuration the flexible display is positioned in a plane located under an obtuse angle with respect to the lower body side. Preferably the device body comprises at the lower body side an extending portion, the lower end of which is configured as surface support part.

In accordance with this aspect of the invention, by positioning in the open position the device body and the support frame under an obtuse angle the device is stably supported on a surface.

According to a "wrap" embodiment of the invention the support frame comprises hinge portions to enable in the closed configuration a wrapped storage position of the flexible display, one of the hinge portions being hingeably connected with the device body, the hingeable connection with the body being located at some distance above a plane through the lower body side of the device body.

According to another "wrap" embodiment of the invention the support frame comprises hinge portions to enable in the closed configuration a wrapped storage position of the flexible display, one of the hinge portions being hingeably connected with the device body, the hingeable connection being located near the lateral end of the extending portion of the device body comprising the surface support part.

According to a "book" embodiment of the invention the support frame comprises two portions, each configured to support a part of the display, the device body at its upper body side being a first portion of the support frame, a second portion of the support frame being hingeably connected with the first portion of the support frame, wherein the hingeable connection in the support frame in the open configuration is being moved upwardly in the direction of the display,

enabling a stable positioning of the device in the open position of the display. This offers a special advantage for substantially symmetrical “book” concepts.

According to an asymmetrical “book” embodiment of the invention the support frame comprises two portions, each configured to support a part of the display, the device body at its upper body side being a first portion of the support frame, a second portion of the support frame being hingeably connected with the first portion of the support frame, in the open configuration the maximum height of the device being largest at the device body side, wherein in the open configuration of the support frame the flexible display is positioned in a plane located under an obtuse angle with respect to the lower sides of both frame portions. This enables a practical and stable open positioning of the display.

According to a “roll type” embodiment of the invention the display is a rollable display, the device body is housing a display roll element, said element extending partially below the lower body side and having a surface support part, in the open configuration the lower body side being positioned by the surface support part of said element under an angle with respect to the surface.

BRIEF DESCRIPTION OF THE DRAWINGS

FIG. 1 shows a perspective view of a ‘wrap’ type device in accordance with the prior art in a storage and an operational position respectively;

FIG. 2 shows a schematic side view of the prior art ‘wrap’ device of FIG. 1 in an operational position put on a surface;

FIG. 3 shows a schematic side view of a symmetrical ‘book’ type device in accordance with the prior art in an operational position put on a surface;

FIG. 4 shows a schematic side view of another symmetrical ‘book’ type device in accordance with the prior art in an operational position put on a surface;

FIG. 5 shows a schematic side view of an asymmetrical ‘book’ type device in accordance with the prior art in an operational position put on a surface;

FIG. 6 shows a perspective view of a ‘roll’ device in accordance with the prior art in an open position put on a surface;

FIG. 7 shows a schematic side view of a ‘wrap’ type device in accordance with the invention in an operational position put on a surface;

FIG. 8 shows a schematic side view of another “wrap” embodiment in a storage position (FIG. 8A) and an open position put on a surface (FIG. 8B), respectively, in accordance with the invention;

FIG. 9 shows a schematic side view of another “wrap” embodiment in an open position put on a surface, in accordance with the invention;

FIG. 10-15 show schematic side views of asymmetrical ‘book’ type embodiments, in accordance with the invention;

FIG. 16 shows a schematic side view of a symmetrical ‘book’ type embodiment in a storage position (FIG. 16A) put on a surface and an open position (FIG. 16B) put on a surface, respectively, in accordance with the invention;

FIG. 17 shows a schematic side view of a ‘roll’ type device in accordance with the invention in an operational position put on a surface.

DETAILED DESCRIPTION

Unless otherwise indicated, all numbers expressing quantities of ingredients, dimensions reaction conditions and so

forth used in the specification and claims are to be understood as being modified in all instances by the term “about”.

In this application and the claims, the use of the singular includes the plural unless specifically stated otherwise. In addition, use of “or” means “and/or” unless stated otherwise. Moreover, the use of the term “including”, as well as other forms, such as “includes” and “included”, is not limiting. Also, terms such as “element” or “component” encompass both elements and components comprising one unit and elements and components that comprise more than one unit unless specifically stated otherwise.

The prior art display device 1 schematically shown in FIGS. 1A and 1B is a ‘wrap’ embodiment as disclosed in WO 2008/054206 A2 (herewith incorporated by reference). It comprises a continuous flexible display 2 and a display support frame comprising two support frame portions 3, 4. These portions 3, 4 are connected via hinge parts 5, 6, each comprising two hinges 5a, 5b and 6a, 6b (shown in FIG. 2) respectively, with a body 7 and are each structurally configured to support a respective portion of the flexible display 2. The two support frame portions are movable between a configuration shown in FIG. 1a with the flexible display in a closed storage position and a planar configuration shown in FIG. 1b with the flexible display in an open position.

In the open position as shown in FIG. 2 when such a device is put on a substantially flat surface 8, the device is unstable when the user is interacting with the device, e.g. by touching buttons on the body 7 to switch pages or touching the display in case it is a touch sensitive display, and the device rotates around the hinge part 6 (arrow a).

In FIG. 3 is schematically shown a symmetrical “book” type prior art embodiment. This device 9 comprises a flexible display and a display support frame with two support frame portions 10, 11 connected via a bridge formed by a curved hinge part 12 provided with two hinges. In such a dual hinge variant of the book, the hinge part can be very big, and therefore sticks out below the frame portions 10, 11. When the device is put on a surface 8, due to this hinge part 12 the device is unstable when the user is interacting with the device, e.g. by touching the display, and the device rotates around the curved hinge part 12 (arrow b).

In FIG. 4 is schematically shown another symmetrical “book” type prior art embodiment. This device 9 comprises between the frame portions 10, 11 a hinge part 13 with an upper wall, offering an underground for the display section in the hinge area. Due to the nature of hinge part 13 the device is unstable when the user is touching the display section in the hinge area, resulting in an upward rotation of the frame portions 10, 11 according to arrow c, d respectively.

A special form of the “book” type prior art device, shown in FIG. 5 is an asymmetric book device 14 with frame portions 15, 16. In this case the frame portion 15 is thick and the other portion 16 thin. This has some advantages such as for weight and volume distribution and touch support. However due to the distance of the frame portion 16 to the surface 8 the wiggle problem might be even larger in this concept when the user is interacting with the device. E.g. by touching the display at the side of the thin portion 16 the device rotates according to arrow e.

Another type of prior art device with a flexible display is the roll type device 17 as shown in FIG. 6 with a rollable display 18 and a housing 19. When such a device in its rolled out display is put on a surface 8, it can also be unstable, similar to the wrap and book-type devices.

The display device 1 of FIG. 7 is an embodiment of the invention and is of the “wrap” type described before and

5

shown in FIGS. 1 and 2. Its device body 7 has upper and lower body sides 7a, 7b. The lower side 7b has near its end a support part 7c for supporting the body on the surface 8. The continuous flexible display 2 is supported by the support frame. The portion 4 of the support frame is hingeably connected by a connection part 20 at the device body 7 and is movable between a closed configuration for fixing the flexible display in a storage position and an open configuration for fixing the flexible display in an open position. The hinge parts 5, 6 are configured at their bottom side as surface support part 5c, 6c for supporting the support frame on the surface 8. In the open configuration shown in FIG. 7 both surface support parts 5c, 6c and the lower body side 7c are positioned in one plane (i.e. the flat surface), enabling a supporting of the surface support parts of the support frame and of the device body on the surface 8 for a stable user interaction with the device in the open position of the display. In this position the display 2 is positioned in a plane located under an obtuse angle 'a' with respect to the lower body side 7b. By this stable positioning the user can interact with buttons on the device body 7 and with the part of the display 2 above the portion 4, without creating unwanted movements of the display.

In another "wrap" type embodiment, shown in a storage position (FIG. 8a) and in an open position put on a surface 8 (FIG. 8b), the device body 7 comprises at the whole lower body side 7b a downwardly and in lateral direction outwardly extending portion 7e. The whole lower side of the portion 7e is configured as surface support part 7b. In this embodiment the hinge axis of hinge 6b is placed a distance h higher than the opposite hinge axis of hinge 5a and the hinge axis of hinge 6b is located at a distance L outwardly with respect to the axis of hinge 6a (see FIG. 8a). As shown in FIG. 8b this embodiment creates a flat shape for the device 1 when placed on a surface 8, i.e. both the support frame with the display 2 and the lower body side 7b are stable positioned substantially parallel to the surface 8. This embodiment enables to use a longer frame portion 3a and creates a longer display 2, whereas the positioning of the hinge part 6 in the storage position of FIG. 8a will not extend further outward than the device body 7 in the open position of FIG. 8b.

In an alternative "wrap" type embodiment, shown in an open position put on a surface 8 in FIG. 9, the device body 7 comprises at the lower side a downwardly and in lateral direction outwardly extending portion 7f with an lower wall configured as surface support part 7b. The portion 7f extends over only a minor part of the underside of the body 7 at the location of the corner of the body 7. The dimensions of a recess 7g at the underside of the body correspond with those of the frame portion 3. Due to the recess 7g and the dimensions of the portion 3 the thickness of the device in the storage position may be less than the thickness of the device shown in FIG. 8.

For stable positioning the device in the open position on a surface, under the body 7 downwardly extending portions, in this embodiment two protrusions 7i, are provided located at opposite sides of the display when the flexible display is in the storage position. Preferably the frame portion 3 comprises at the opposite sides recesses enabling positioning the protrusions 7i in the storage position of the display.

A variation of this solution would be to make these local protrusions 7i movable, preferably retractable from the open to the storage position. In open position of the device they move out of the device and become locked in their extended

6

state. In this way these protrusions 7i do not necessarily need to be located at the sides of the support frame, but can be below them.

A schematic side view of an asymmetrical 'book' device 20 of the type shown before in FIG. 5, is shown in FIG. 10a in the storage position and FIG. 10b in the open position. In this embodiment the support frame comprises two portions 21, 22 each configured to support a part of the display 2. The device body at its upper body side is the first portion 21 of the support frame, whereas the second portion 22 is connected via a hinge 23 with the first portion 21. In the open configuration of FIG. 10b with the lower sides of the portions 21, 22 positioned on the surface 8 the maximum height of the device is largest at the device body side remote from the hinge 23 and smallest at the end of the portion 22. Due to this configuration of the device the flexible display 2 is stably positioned in a plane located under a sharp angle ' β ' with respect to the lower sides of both frame portions. In the storage position of FIG. 10a is shown that the whole of a curved portion 2a of the display is located in the portion 21 of the device body near the hinge 23.

In the asymmetrical 'book' device shown in FIG. 11a alternatively a curved portion 2b of the display 2 may be located partly in the portion 21 of the device body and partly in the frame portion 22 near the hinge 23.

In the embodiments of FIGS. 10 and 11 in the open position shown in FIG. 10b, 11b the display 2 is positioned on the surface 8 in a comfortable reading position. It is noted that in the embodiment of FIG. 10 in the open position shown in FIG. 10b the supporting surface under the display of the portion 2a is larger than in the portion 2b in the open position of the embodiment of FIG. 11, shown in FIG. 11b. In the embodiment of FIG. 10 the recess in the supporting surface for the portion 2a is only configured in the portion 21, whereas in the embodiment of FIG. 11 the recess for the portion 2b is configured in both the portion 21 and the portion 22.

In FIG. 12 is shown a schematic side view of another asymmetrical 'book' device 24 of the type shown before in FIG. 5. In this embodiment the device 24 comprises two frame portions 25, 26 each configured to support a part of the display 2. The device body at its upper body side is a first portion 25 of the support frame, connected by a hinge 27 with a second portion 26 of the support frame. In the storage position of FIG. 12a is shown that the whole of a curved portion 2c of the display is located in the device body near the hinge 27.

In the open configuration of FIG. 12b the maximum height of the device is largest at the device body side. The second portion 26 comprises a surface support part 26a. In the open position of the display the surface support part 26a can be moved by further rotating around the axis of hinge 27 in the direction of arrow k to a locked operational position enabling to compensate the height difference of the device at both sides of the hingeable connection. Thus in the open position of the display a stable horizontal positioning of the display and the device on the surface 8 is ensured.

In FIG. 13 is shown a schematic side view of another asymmetrical 'book' device 24 of the type shown before in FIG. 5. In this embodiment at both lateral sides of the device a surface support part 26a is movable connected via a hinge 28 with the second portion 26 of the support frame. In the storage position shown in FIG. 13a these parts 26a are positioned in recesses 25a in the device body with the hinges 28 neighboring the recesses 25a. During movement to the operational position these surface support parts 26a move around the hinge 28 to the position shown in FIG. 13b,

These parts 26a enable to compensate the height difference of the device at both sides of the hinge 27 and thus enable a stable horizontal position of the display 2 on the surface 8. Alternatively only one support part 26a is applied extending over the whole width of the device,

In FIG. 14b is shown in the operational position an alternative embodiment of the device shown in FIG. 13 with means for enabling compensating the height difference of the device at both sides of the hinge 27. The means are in FIG. 14 configured as surface support parts 26b connected with the second portion 26 via hinges 29 located at the upper side of the device 24. In the storage position of FIG. 14a the surface support parts 26b are stored as a continuous part of the second portion 26. Alternatively only one support part 26b is applied extending over the whole width of the device,

In FIG. 15b is shown in the operational position another alternative embodiment of the device shown in FIG. 13 with means for enabling compensating the height difference of the device at both sides of the hinge 27, in this embodiment surface support parts 26c, connected with the second portion 26 via hinges 30 located at the end of the second portion 26 remote from the hinge 27. In the storage position of FIG. 15a the surface support parts 26c are stored in recesses 26d in the second portion 26. Alternatively only one support part 26c is applied extending over the whole width of the device,

In FIG. 16 is schematically shown in side view a symmetrical “book” type of the type shown in FIG. 3 in the storage position (FIG. 16a) and open position (FIG. 16b). This device 9 comprises a flexible display 2 and a display support frame with two support frame portions 10, 11 connected via a hinge part 12. Two hinges 31, 32 are guided in slots 33 located in the hinge part 12 and extending substantially parallel in the frame portions 10, 11. As shown in FIG. 16b the hinge part 12 is moved upwardly when the device is opened and put on the surface 8. Since the bottom side of part 12 is now in line with the bottom side of the frame portions 10, 11 the device is positioned stably on the surface 8.

It is noted that preferably at least one of the desk support parts 26a of the embodiment of FIG. 13, the desk support parts 26b of the embodiment of FIG. 14 and the desk support part 26c of the embodiment of FIG. 15 is operational in the closed position of the support frame for locking the flexible display in the storage position.

In FIG. 17 is schematically shown in side view a “roll” device 17 of the type of FIG. 3 in the open configuration. The device body 19 houses a display roll element 40 that extends partially below the lower body side 19a and is provided with a surface support part 19b. In the open configuration the display 18 is rolled outside the device body 19 and supported in a flat position by a support frame 41. In this configuration the lower body side 19a is positioned by the surface support part 19b under an angle with respect to the surface 8, whereas the display 18 is positioned in a plane located under an obtuse angle with respect to the lower body side 19a. By this stable positioning the user can interact with buttons on the device body 19 and with the display 18, without creating unwanted movements of the display. In this embodiment in the open position the display 18 is located on the surface 8 in a comfortable reading position.

Various embodiments of the disclosure could also include permutations of the various elements recited in the claims as if each dependent claim was a multiple dependent claim incorporating the limitations of each of the preceding dependent claims as well as the independent claims. Such permutations are expressly within the scope of this disclosure.

While the invention has been particularly shown and described with reference to a number of embodiments, it would be understood by those skilled in the art that changes in the form and details may be made to the various embodiments disclosed herein without departing from the spirit and scope of the invention and that the various embodiments disclosed herein are not intended to act as limitations on the scope of the claims. All references cited herein are incorporated in their entirety by reference.

What is claimed is:

1. A display device comprising:

a device body with upper and lower body sides and having at least one surface support part for supporting the device body on a surface;

a continuous flexible display; and

a support frame configured to support at least a part of the flexible display and comprising:

a hinge portion rotatably connected with the device body, wherein the support frame is movable with respect to the device body between a closed configuration for fixing the flexible display in a storage position and an open configuration for fixing the flexible display in an open position; and

at least one surface support part for supporting the support frame on a surface;

wherein in the open configuration the at least one surface support part of the support frame and the surface support part of the lower body side are positioned in one plane, enabling a supporting of the surface support parts of the support frame and of the device body on a surface for a stable user interaction with the device in the open position of the flexible display,

wherein in the closed configuration the device body is partially covered by a portion of the support frame, and the flexible display is sandwiched between the device body and the portion of the support frame, and

wherein the flexible display is a rollable display, the device body houses a display roll element, said element extending partially below the lower body side and having a surface support part, arranged such that in the open configuration the lower body side is positioned by the surface support part of said element at an angle with respect to the surface.

2. The display device in accordance with claim 1, wherein in the open configuration the rollable display is positioned at an obtuse angle with respect to the lower body side.

3. A device comprising:

a flexible display comprising a first portion, a second portion and a third portion located between the first portion and the second portion;

a display support frame including a first support frame portion supporting the first portion and a second support frame portion supporting the second portion; and

a hinge module connecting the first support frame portion and the second support frame portion,

wherein the hinge module is positioned in line with a side of the first support frame portion and a side of the second support frame portion when the device is opened, and

wherein the display support frame comprises a recess configured to accommodate the third portion of the flexible display and to confine a curvature of the third portion of the flexible display when the device is closed.

4. The device of claim 3, wherein the hinge module comprises at least one slot which extends substantially parallel in the frame portions when the device is closed.

5. The device of claim 4, wherein the hinge module comprises at least one hinge, and the at least one hinge is moved along with the at least one slot while the device is opened.

6. The device of claim 3, wherein the hinge module 5 comprises a first hinge and a second hinge, the first hinge is inserted in a first slot, and the second hinge is inserted in a second slot.

7. The device of claim 6, wherein the first hinge is moved along with the first slot and the second hinge is moved along 10 with the second slot while the device is opened.

* * * * *