



US00RE47694E

(19) **United States**
(12) **Reissued Patent**
Buoni et al.

(10) **Patent Number:** **US RE47,694 E**
(45) **Date of Reissued Patent:** **Nov. 5, 2019**

(54) **WALL PANEL**

(56) **References Cited**

(71) Applicant: **Boral Stone Products LLC**, Roswell, GA (US)

U.S. PATENT DOCUMENTS

(72) Inventors: **Wayne Joseph Buoni**, Johns Creek, GA (US); **Douglas Edward Lehman**, Angwin, CA (US); **Douglas M. McCaskey**, Sylvania, OH (US)

448,733 A	3/1891	Sagendorph
897,353 A	9/1908	Culley
1,276,894 A	8/1918	Flanders
1,592,591 A	7/1926	Amele
1,688,405 A	10/1928	Stoehr
1,853,822 A	4/1932	Krauss
1,853,824 A	4/1932	Krauss
1,859,539 A	5/1932	Slidell
1,872,522 A	8/1932	Stuckey
1,976,947 A	10/1934	Krauss
2,006,635 A	7/1935	Farr
2,030,556 A	2/1936	Veltung
2,031,680 A	2/1936	Tuthill

(73) Assignee: **Boral Stone Products LLC**, Roswell, GA (US)

(21) Appl. No.: **15/423,504**

(Continued)

(22) Filed: **Feb. 2, 2017**

FOREIGN PATENT DOCUMENTS

Related U.S. Patent Documents

Reissue of:

(64) Patent No.: **9,027,302**
Issued: **May 12, 2015**
Appl. No.: **13/569,762**
Filed: **Aug. 8, 2012**

EP	0182567	5/1986
FR	2461073	1/1981

(Continued)

OTHER PUBLICATIONS

Office Action received in related U.S. Appl. No. 14/299,250, dated Aug. 30, 2017.

(Continued)

(51) **Int. Cl.**

E04F 19/00 (2006.01)
E04F 13/073 (2006.01)
E04F 13/08 (2006.01)
E04F 13/18 (2006.01)

Primary Examiner — Cary E Wehner

(74) *Attorney, Agent, or Firm* — Bookoff McAndrews, PLLC

(52) **U.S. Cl.**

CPC **E04F 13/185** (2013.01); **E04F 13/0733** (2013.01); **E04F 13/0837** (2013.01)

(57) **ABSTRACT**

(58) **Field of Classification Search**

CPC **E04F 13/072**; **E04F 13/0733**; **E04F 13/185**
USPC **52/311.3**, **312-314**, **384**, **506.01**, **506.06**,
52/535, **588.1**, **554**, **302.6**, **536**, **543**, **546**,
52/511, **519**, **551**

A universal corner panel includes a first surface comprising a first portion and a second portion. The first portion has a first surface topography with a first delta and the second portion has a second surface topography with a second delta. The first delta is substantially different than the second delta.

See application file for complete search history.

12 Claims, 12 Drawing Sheets

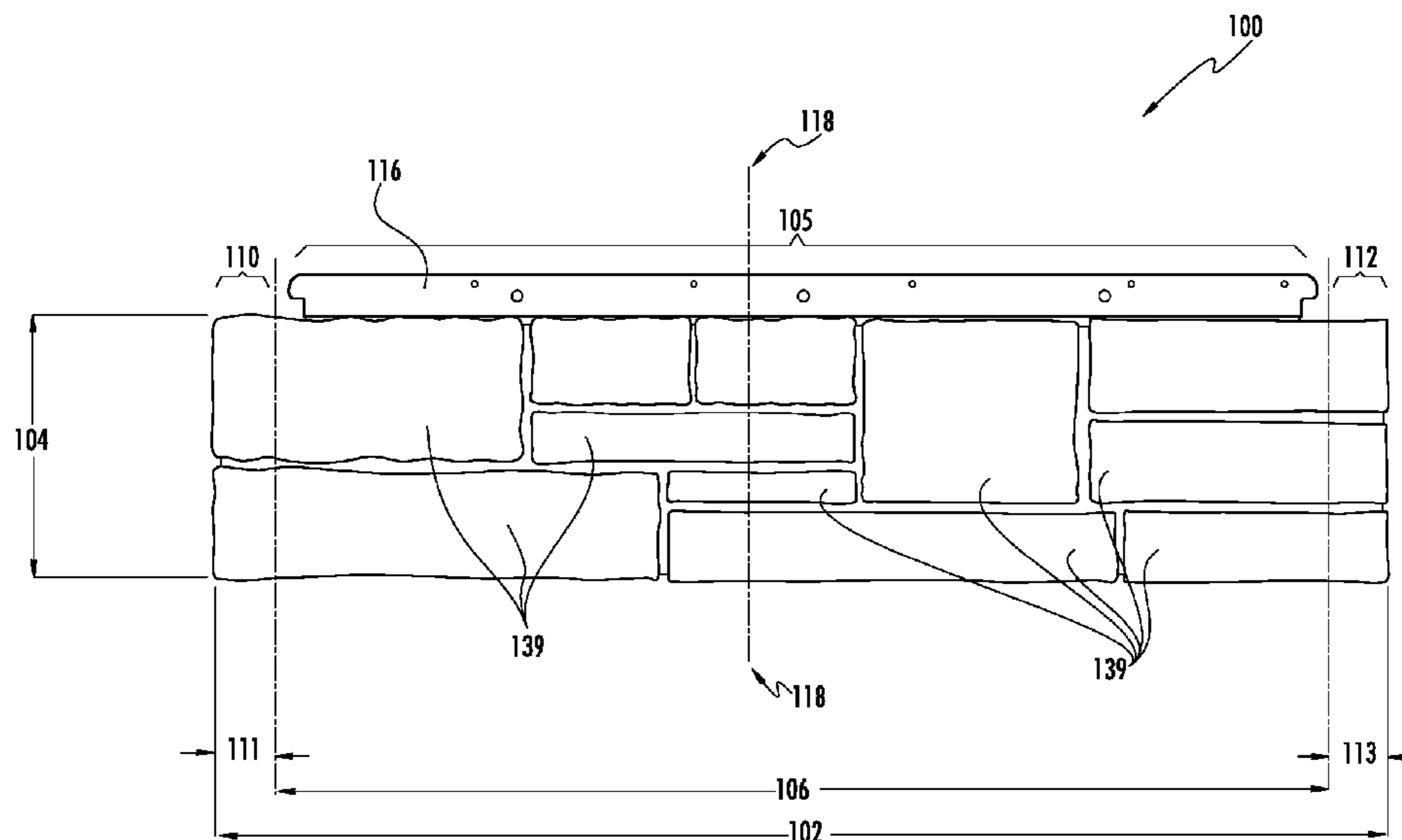

(56)

References Cited

U.S. PATENT DOCUMENTS

2,182,523 A	12/1939	Markowski et al.	4,689,931 A	9/1987	Hodges et al.
2,198,466 A	4/1940	Stolze	4,773,201 A	9/1988	Trezza
2,209,283 A	7/1940	Ronzzone	4,858,410 A	8/1989	Goldman
2,214,387 A	9/1940	Snyder	4,932,182 A	6/1990	Thomasson
2,300,258 A	10/1942	Kublanow	4,944,124 A *	7/1990	Armstrong 52/169.12
2,305,280 A *	12/1942	Strunk et al. 52/276	4,946,632 A	8/1990	Pollina et al.
D135,475 S	4/1943	Wright	5,042,215 A	8/1991	Cremer et al.
D135,476 S	4/1943	Wright	5,052,161 A	10/1991	Whitacre
2,317,428 A	4/1943	Anderson	5,072,562 A	12/1991	Crick et al.
2,329,610 A	9/1943	Harman	5,076,037 A	12/1991	Crick et al.
2,592,244 A	4/1952	Chamberlain	5,172,532 A	12/1992	Gibbar, Jr.
2,884,780 A	5/1959	Ramirez	5,228,249 A	7/1993	Campbell
2,991,592 A	7/1961	Rauen	5,228,937 A	7/1993	Passeno
3,004,369 A	10/1961	Findlay	5,232,646 A	8/1993	Nasvik et al.
3,131,514 A	5/1964	Siek	5,271,878 A	12/1993	Mizia et al.
3,142,938 A	8/1964	Eberhardt	5,311,714 A	5/1994	Passeno
3,177,279 A	4/1965	Bilodeau	5,347,784 A	9/1994	Crick et al.
3,217,453 A *	11/1965	Medow 52/314	5,373,676 A	12/1994	Francis et al.
3,232,017 A	2/1966	Prusinski et al.	5,379,561 A	1/1995	Saito
3,248,834 A	5/1966	Polis	5,398,473 A	3/1995	Chan
3,310,921 A	3/1967	Forcadell	5,515,659 A	5/1996	MacDonald et al.
3,332,187 A	7/1967	Arcari	5,537,792 A	7/1996	Moliere
3,335,048 A	8/1967	Morain	5,540,023 A	7/1996	Jaenson
3,344,011 A	9/1967	Goozner	5,557,897 A	9/1996	Kranz et al.
3,350,827 A	11/1967	Sugar et al.	5,634,305 A	6/1997	Erlanger
3,478,479 A	11/1969	Papalia et al.	5,637,236 A *	6/1997	Lowe 216/39
3,496,694 A	2/1970	Hicks et al.	5,673,529 A	10/1997	Treister et al.
3,521,418 A	7/1970	Bartoloni	5,715,637 A	2/1998	Hesterman et al.
3,524,790 A	8/1970	Mason	5,787,666 A	8/1998	Sherry
3,533,206 A	10/1970	Passeno, Jr.	5,819,486 A	10/1998	Goodings
3,613,326 A *	10/1971	Mollman 52/314	5,833,895 A	11/1998	Di Loreto
3,618,888 A	11/1971	Wise	5,836,123 A *	11/1998	Gulino 52/288.1
3,621,625 A *	11/1971	Medow 52/314	5,836,572 A	11/1998	Sugiyama
3,646,715 A	3/1972	Pope	5,857,303 A	1/1999	Beck et al.
3,683,579 A	8/1972	Beardsley	5,878,543 A	3/1999	Mowery
3,701,228 A	10/1972	Taylor	5,916,103 A	6/1999	Roberts
3,740,910 A	6/1973	Taylor et al.	5,956,914 A	9/1999	Williamson
3,750,998 A	8/1973	Shoe et al.	5,966,886 A	10/1999	Di Loreto
3,754,365 A	8/1973	Carrick et al.	6,029,418 A	2/2000	Wright
3,867,503 A	2/1975	Shoe et al.	6,050,037 A	4/2000	Gifford
3,868,801 A	3/1975	Weiner	6,134,855 A	10/2000	Beck
3,885,008 A	5/1975	Martin	6,151,854 A	11/2000	Gutjahr
3,899,344 A	8/1975	Jakel	6,164,029 A	12/2000	Lee
3,905,170 A	9/1975	Huettemann	6,237,288 B1	5/2001	Jenkins et al.
3,908,326 A	9/1975	Francis	6,237,294 B1	5/2001	Rygiel
3,968,610 A *	7/1976	Medow 52/314	6,240,691 B1	6/2001	Holzkaemper et al.
4,001,361 A *	1/1977	Unruh 264/51	6,244,009 B1	6/2001	Cerrato
4,011,702 A	3/1977	Matyas	6,253,511 B1	7/2001	Boyer
4,026,083 A	5/1977	Hoyt et al.	6,253,515 B1	7/2001	Kuelker
4,034,528 A	7/1977	Sanders	6,295,777 B1	10/2001	Hunter et al.
4,037,377 A	7/1977	Howell et al.	6,315,489 B1	11/2001	Watanabe
4,065,902 A	1/1978	Lindal	6,324,807 B1	12/2001	Ishiko
4,191,521 A	3/1980	Muldery et al.	6,336,303 B1	1/2002	Vandeman et al.
4,219,984 A	9/1980	De San	6,355,193 B1	3/2002	Stott
4,223,490 A *	9/1980	Medow 52/98	6,408,585 B1	6/2002	Tajima
4,241,554 A	12/1980	Infantino	6,460,301 B1	10/2002	McKee et al.
4,266,382 A *	5/1981	Tellman 52/316	6,467,229 B2	10/2002	Azar
4,271,111 A	6/1981	Sheber	6,516,578 B1	2/2003	Hunsaker
4,299,069 A	11/1981	Neumann	6,599,452 B1 *	7/2003	Ferguson 264/46.4
4,306,395 A	12/1981	Carpenter et al.	6,609,342 B2	8/2003	Hikai
4,349,588 A	9/1982	Schiffer	6,615,560 B2	9/2003	Ito
4,404,158 A	9/1983	Robinson et al.	6,634,617 B2	10/2003	Potvin
4,407,104 A	10/1983	Francis	6,701,683 B2	3/2004	Messenger et al.
4,453,359 A	6/1984	Robinson et al.	6,729,090 B2	5/2004	Messenger et al.
4,468,903 A	9/1984	Eaton et al.	6,792,727 B2	9/2004	Krieger
4,495,738 A	1/1985	Sheber	D497,013 S	10/2004	Hughes
4,522,002 A	6/1985	Davis et al.	6,802,165 B1	10/2004	Passeno
4,553,366 A	11/1985	Guerin	6,808,667 B2	10/2004	Nasvik et al.
4,589,241 A	5/1986	Volpenhein	6,820,383 B2 *	11/2004	Vos 52/311.1
4,638,617 A	1/1987	James	6,830,405 B2	12/2004	Watanabe
4,644,719 A	2/1987	Salazar	6,857,248 B2	2/2005	Ouellet et al.
4,655,719 A	4/1987	Sunray	6,898,908 B2	5/2005	Messenger et al.
4,656,722 A *	4/1987	Armstrong 29/527.2	6,904,780 B2	6/2005	Bullinger et al.
4,665,673 A	5/1987	Diana	D510,146 S	9/2005	Attebery, II et al.
4,669,238 A	6/1987	Kellis et al.	6,951,086 B2	10/2005	Passeno
			6,955,019 B2	10/2005	Donlin et al.
			6,968,659 B2	11/2005	Boyer
			6,973,756 B2	12/2005	Hatzinikolas
			6,990,778 B2	1/2006	Passeno

(56)

References Cited

U.S. PATENT DOCUMENTS

RE39,091 E 5/2006 Kuelker
 7,096,629 B1 8/2006 Cox
 7,240,461 B1 7/2007 Vandeman et al.
 7,587,871 B2 9/2009 Perry
 7,617,647 B2 11/2009 Turner et al.
 7,647,738 B2* 1/2010 Nasvik 52/389
 7,735,287 B2 6/2010 Gaudreau
 7,997,039 B2 8/2011 Wolf et al.
 8,042,309 B2* 10/2011 Wolf et al. 52/314
 8,151,530 B2* 4/2012 Schwarz et al. 52/314
 8,201,372 B2 6/2012 Holt et al.
 2003/0066259 A1 4/2003 Sudweeks
 2004/0006943 A1* 1/2004 Weick 52/315
 2004/0107663 A1 6/2004 Waggoner
 2005/0005556 A1 1/2005 Collier et al.
 2005/0102946 A1 5/2005 Stucky et al.
 2005/0188642 A1* 9/2005 Correia 52/506.1
 2005/0204666 A1 9/2005 Passeno
 2005/0210811 A1 9/2005 Nasvik
 2005/0229500 A1 10/2005 Howard
 2005/0252144 A1 11/2005 MacDonald et al.
 2005/0257475 A1 11/2005 Gong et al.
 2006/0053743 A1 3/2006 Hatzinikolas
 2006/0075712 A1 4/2006 Gilbert et al.
 2006/0107610 A1 5/2006 Boserio
 2006/0156668 A1 7/2006 Nasvik
 2006/0191228 A1* 8/2006 Perry 52/506.01
 2006/0191232 A1 8/2006 Salazar et al.
 2006/0260223 A1 11/2006 Wang
 2006/0265988 A1 11/2006 Fujito
 2007/0022687 A1* 2/2007 Correia 52/311.1
 2007/0044402 A1 3/2007 Hess
 2007/0137127 A1 6/2007 Lincoln
 2007/0137128 A1 6/2007 Viau et al.
 2007/0144087 A1 6/2007 Heath et al.
 2007/0151190 A1 7/2007 Huff et al.
 2007/0175159 A1 8/2007 Minitier
 2007/0209308 A1* 9/2007 Barrett 52/506.05
 2007/0227087 A1 10/2007 Nasr et al.
 2008/0005994 A1 1/2008 Harney
 2008/0028711 A1 2/2008 Logan et al.
 2008/0110116 A1 5/2008 Brown et al.
 2008/0115435 A1 5/2008 Riviere
 2008/0155921 A1 7/2008 Wolf et al.
 2008/0302050 A1 12/2008 Kalkanoglu

2008/0313988 A1 12/2008 MacDonald
 2009/0049765 A1 2/2009 Grant
 2009/0056257 A1* 3/2009 Mollinger et al. 52/314
 2009/0094914 A1 4/2009 Jambois et al.
 2009/0113837 A1 5/2009 Mickelson
 2009/0154676 A1 6/2009 Schwartz
 2009/0193742 A1* 8/2009 Wolf et al. 52/311.1
 2009/0235600 A1* 9/2009 Logan et al. 52/314
 2009/0249719 A1* 10/2009 Broehl et al. 52/250
 2009/0304459 A1 12/2009 MacDonald et al.
 2011/0175255 A1* 7/2011 Wernette et al. 264/271.1
 2011/0239578 A1 10/2011 Wolf et al.
 2014/0041331 A1 2/2014 Buoni et al.

FOREIGN PATENT DOCUMENTS

FR	2768452	3/1999
GB	444503	3/1936
JP	200226926	8/2000
JP	200297518	10/2000
WO	2006/042883	4/2006

OTHER PUBLICATIONS

Office Action dated Jun. 6, 2014 in U.S. Appl. No. 13/569,762.
 Office Action dated Aug. 26, 2013 in U.S. Appl. No. 13/569,762.
 Office Action dated Feb. 26, 2014 in U.S. Appl. No. 13/569,762.
 Notice of Allowance dated Oct. 21, 2014 in U.S. Appl. No. 13/569,762.
 Office Action dated Dec. 21, 2010 in U.S. Appl. No. 12/026,876.
 Office Action dated Jun. 19, 2012 in U.S. Appl. No. 12/026,876.
 Office Action dated Jan. 19, 2010 in U.S. Appl. No. 12/026,876.
 Office Action dated Oct. 15, 2012 in U.S. Appl. No. 12/026,876.
 Office Action dated May 25, 2011 in U.S. Appl. No. 12/026,876.
 Office Action dated Jun. 16, 2010 in U.S. Appl. No. 12/026,876.
 Office Action dated Jan. 19, 2017 in U.S. Appl. No. 14/299,250.
 Pulp Art Surfaces catalog, published on May 27, 2011.
 Written Opinion and Search Report of the International Searching Authority for PCT/US2007/025532, dated Apr. 21, 2008.
 Non-Final Office Action issued in U.S. Appl. No. 14/299,250, dated Dec. 1, 2017.
 Non-Final Office Action issued in U.S. Appl. No. 14/879,827, dated Jan. 26, 2018.
 Pulp Art Surfaces catalog, May 27, 2011.*
 Related U.S. Appl. No. 12/026,876, filed Feb. 6, 2008.

* cited by examiner

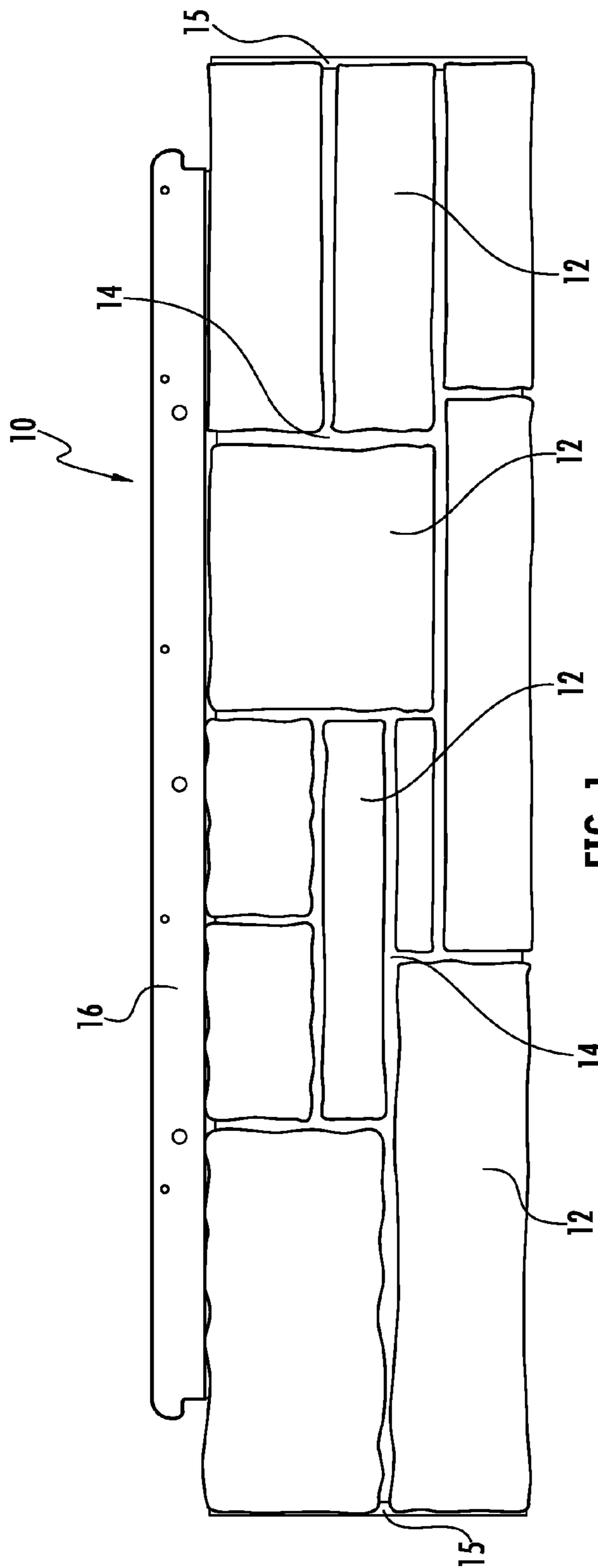

FIG. 1
(PRIOR ART)

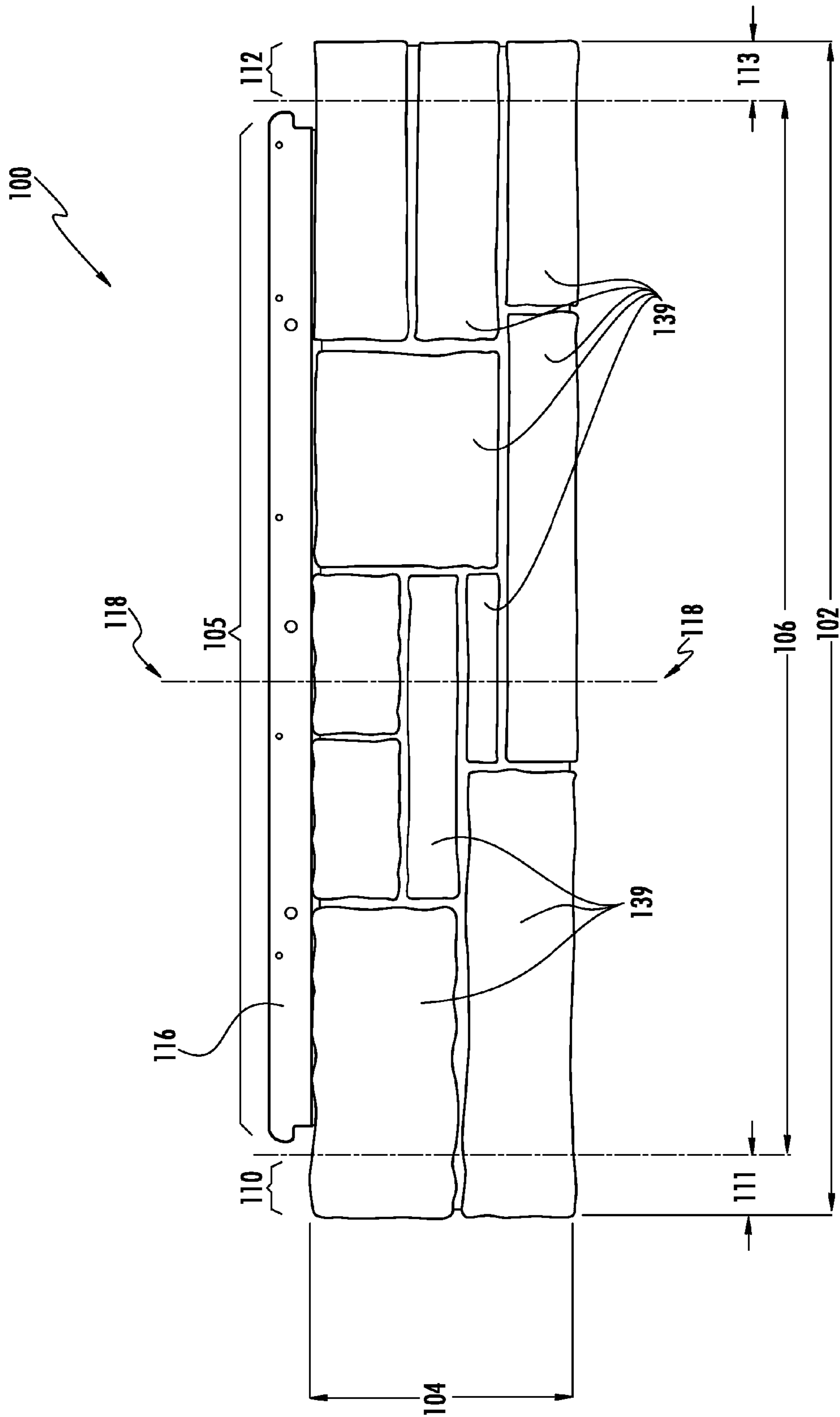

FIG. 2

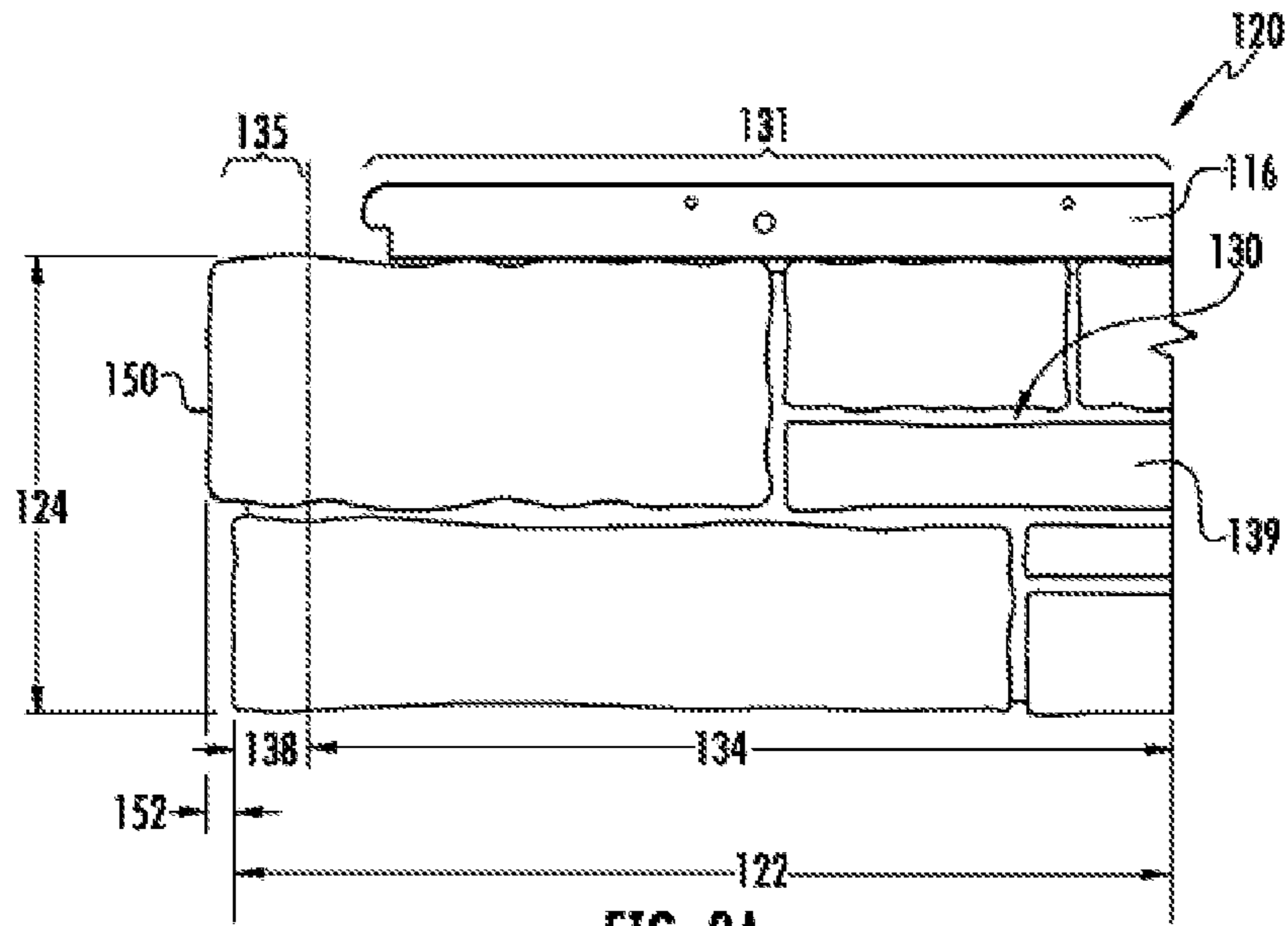

FIG. 3A

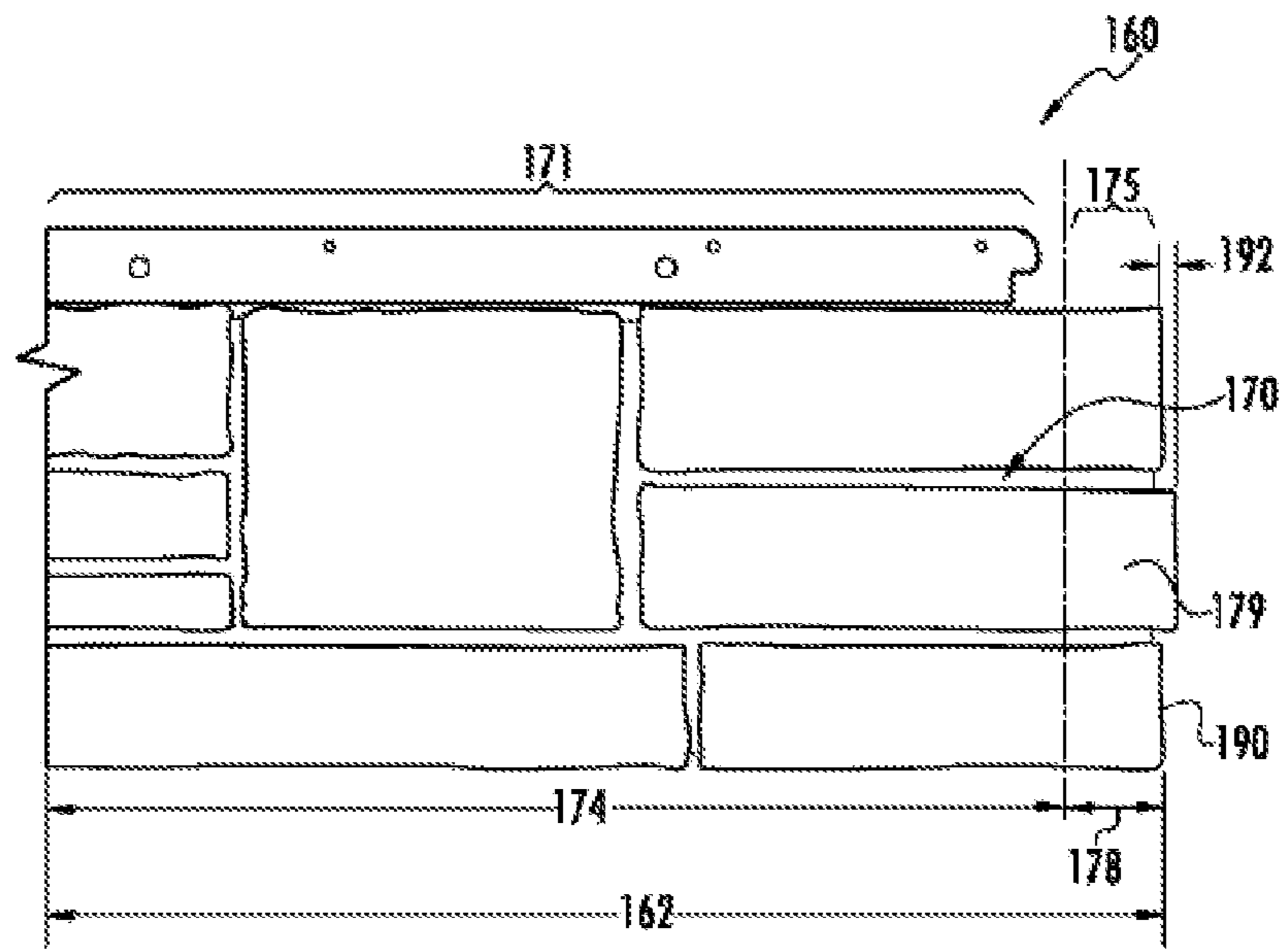

FIG. 3B (AMENDED)

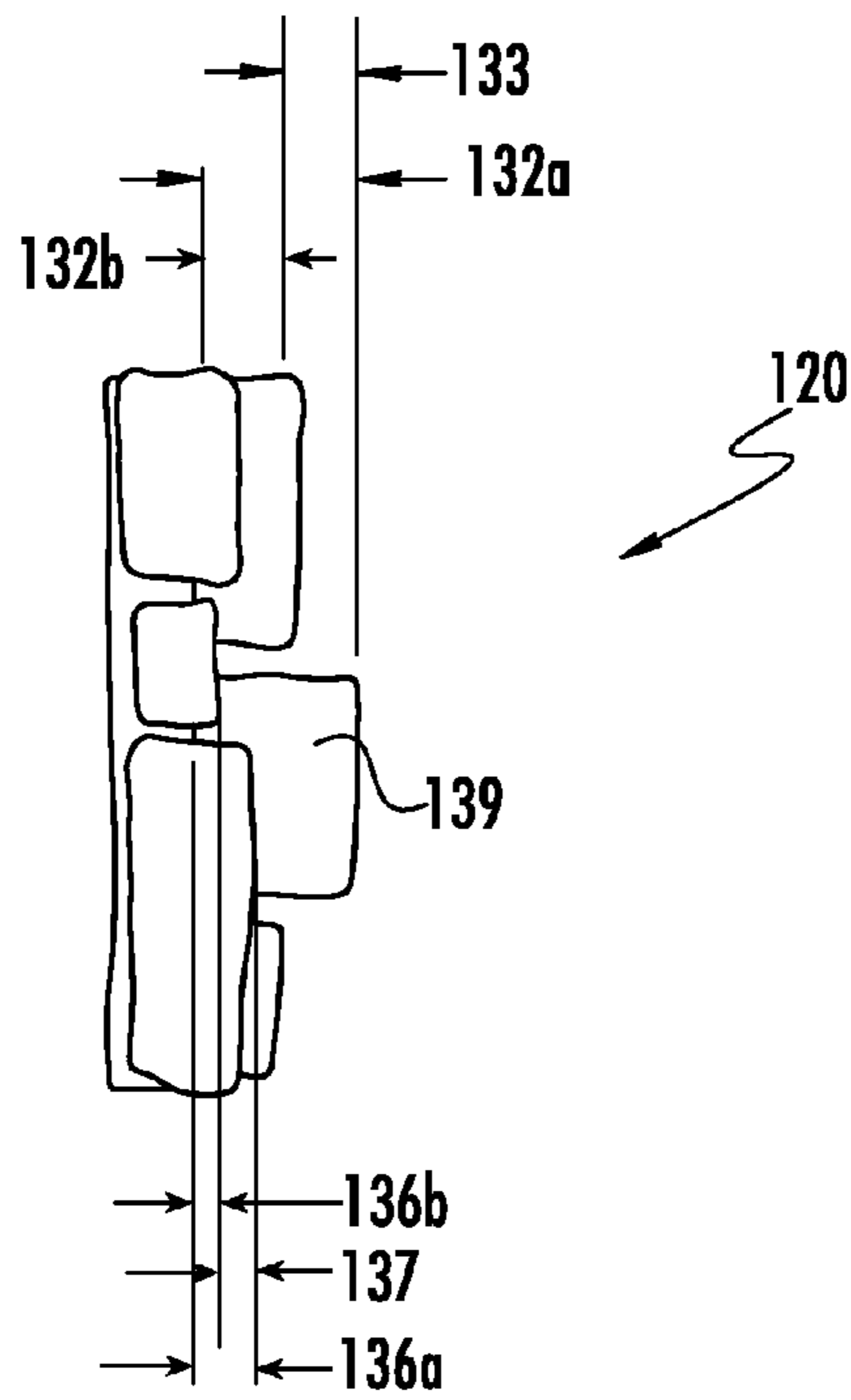

FIG. 3C

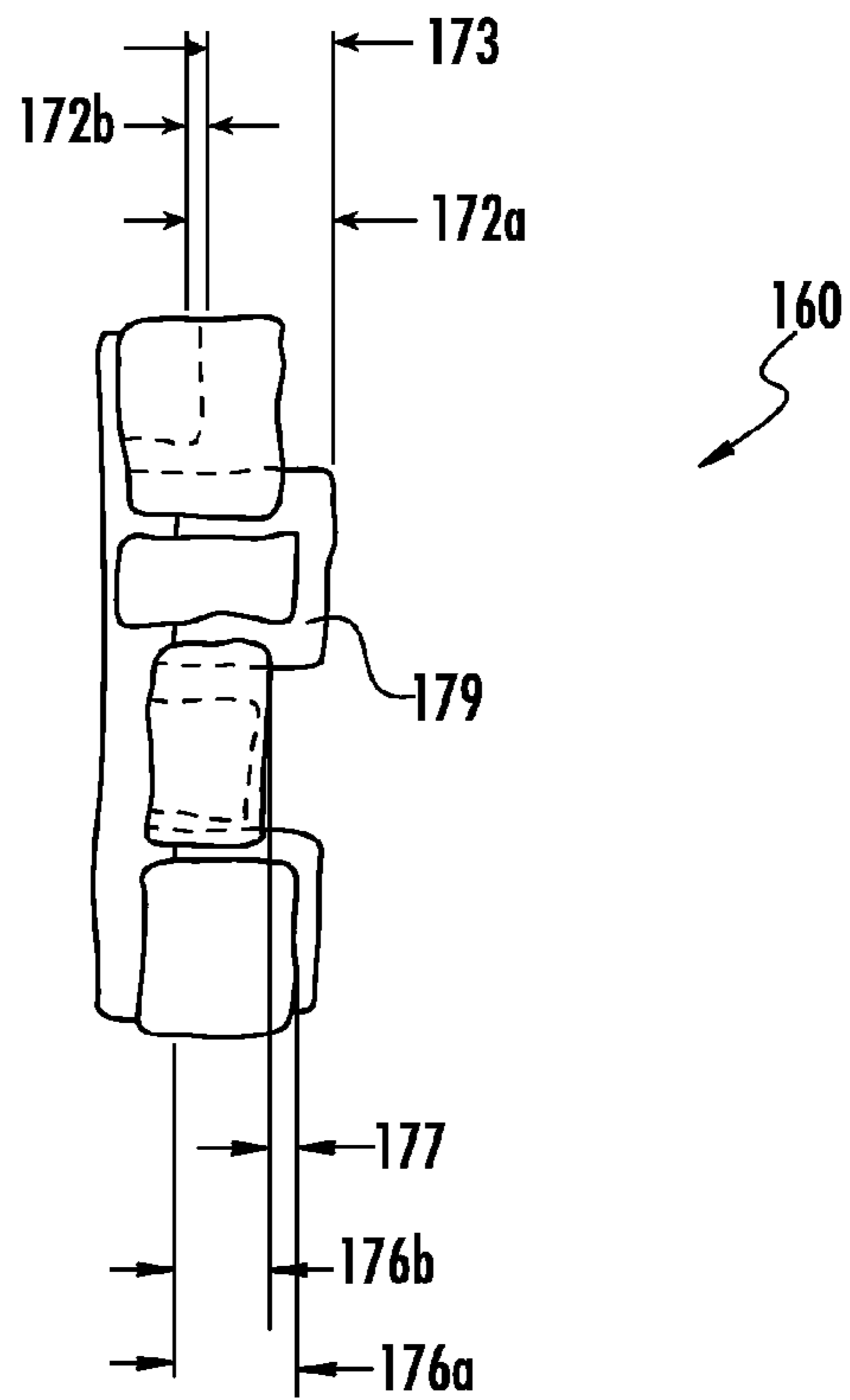

FIG. 3D

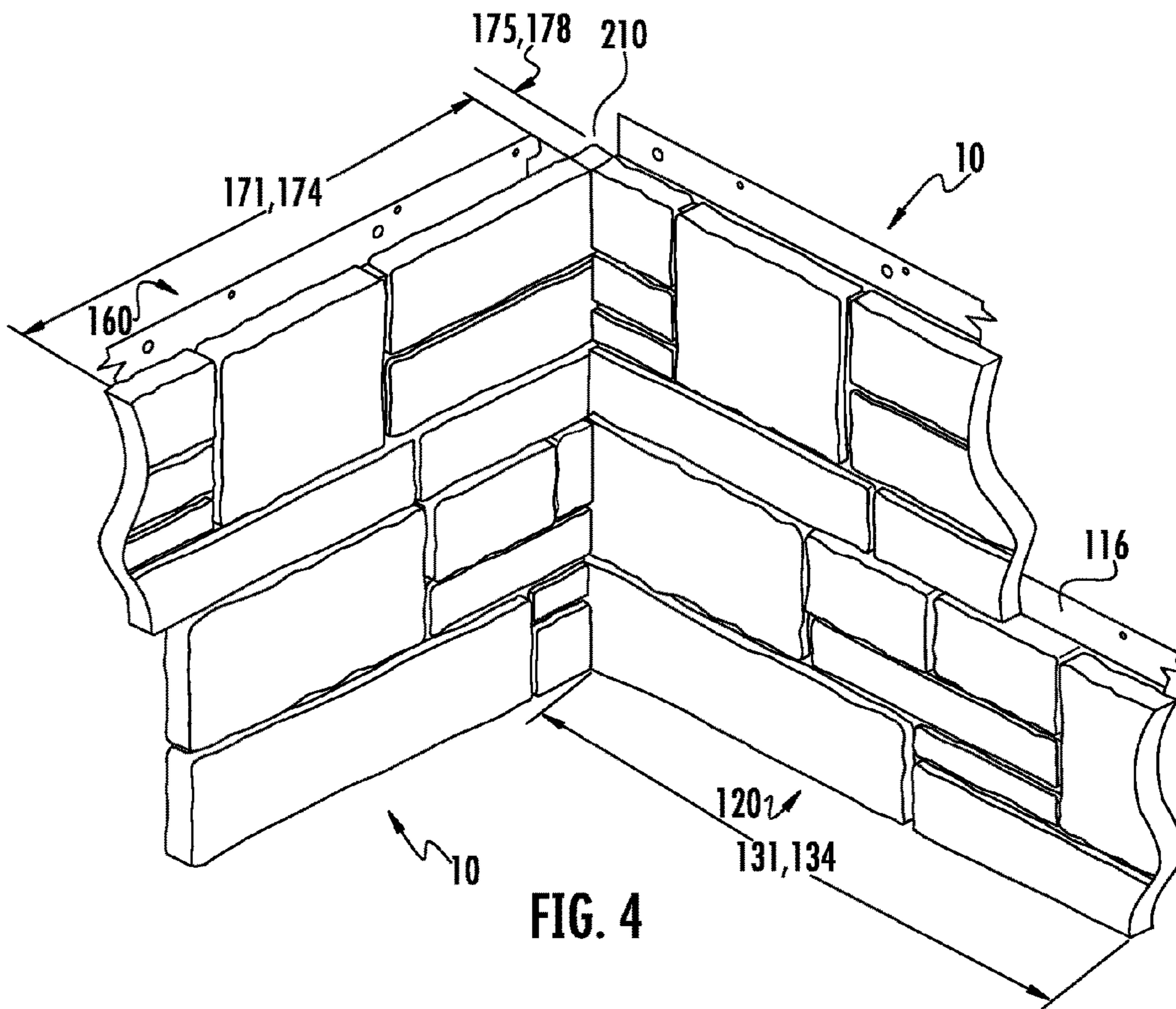

FIG. 4

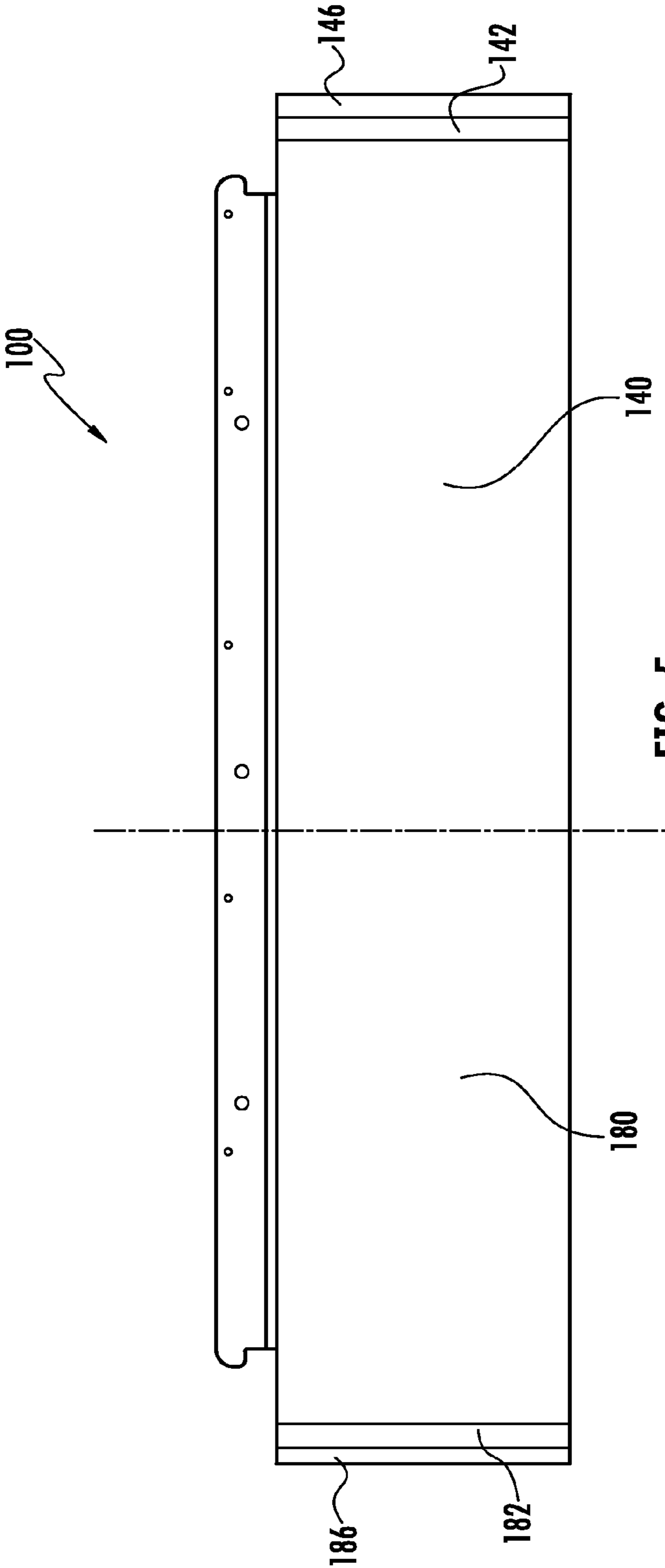

FIG. 5

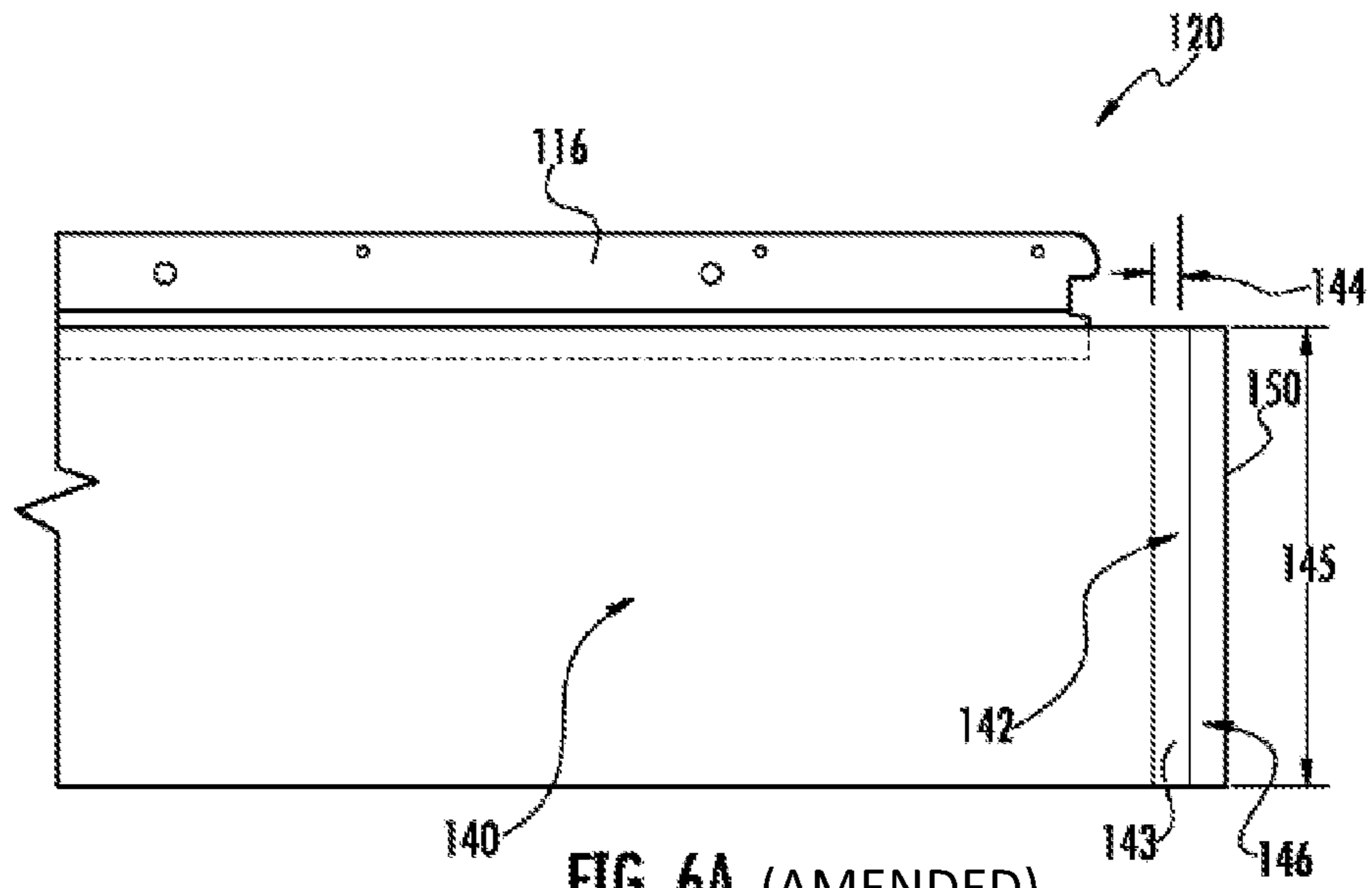

FIG. 6A (AMENDED)

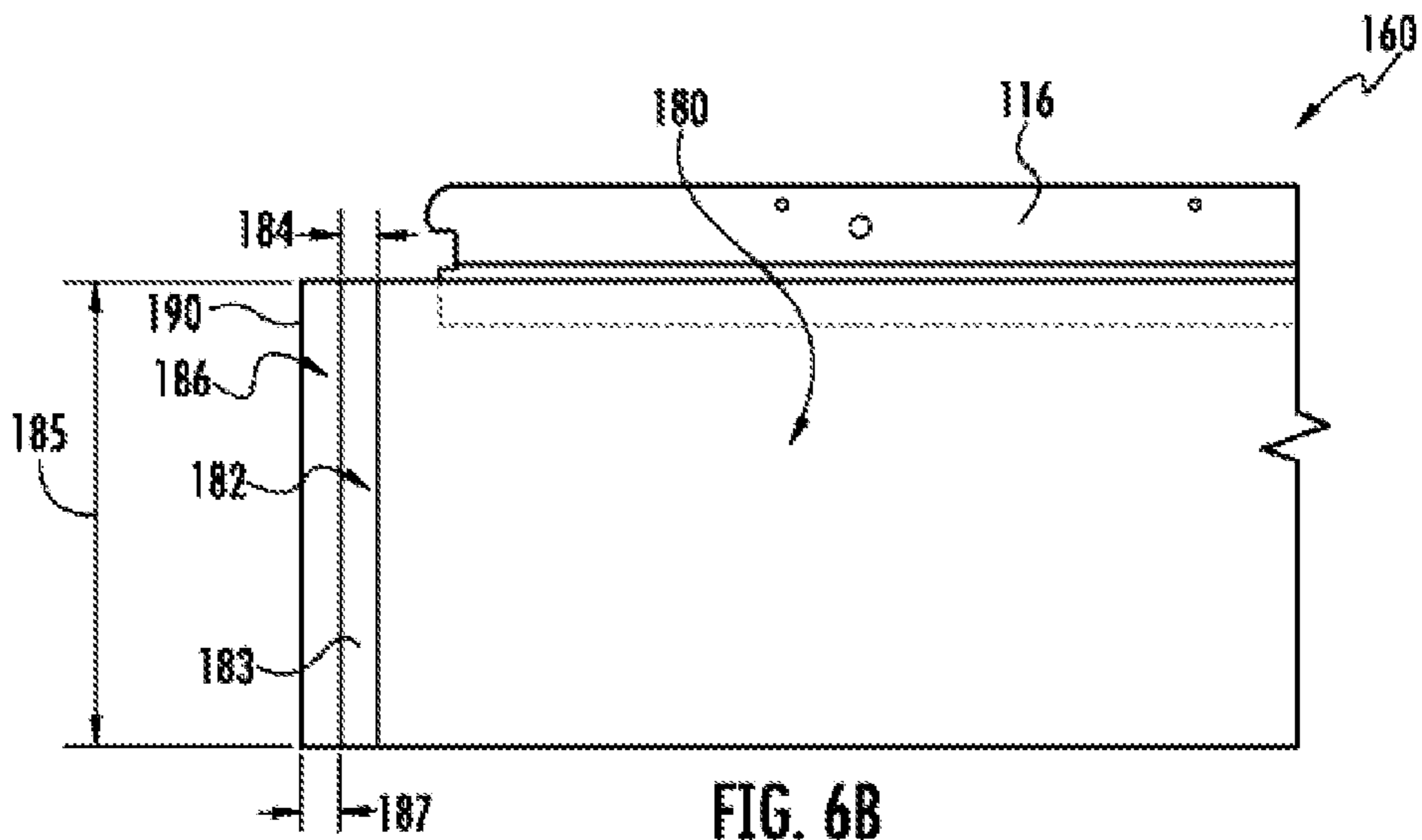
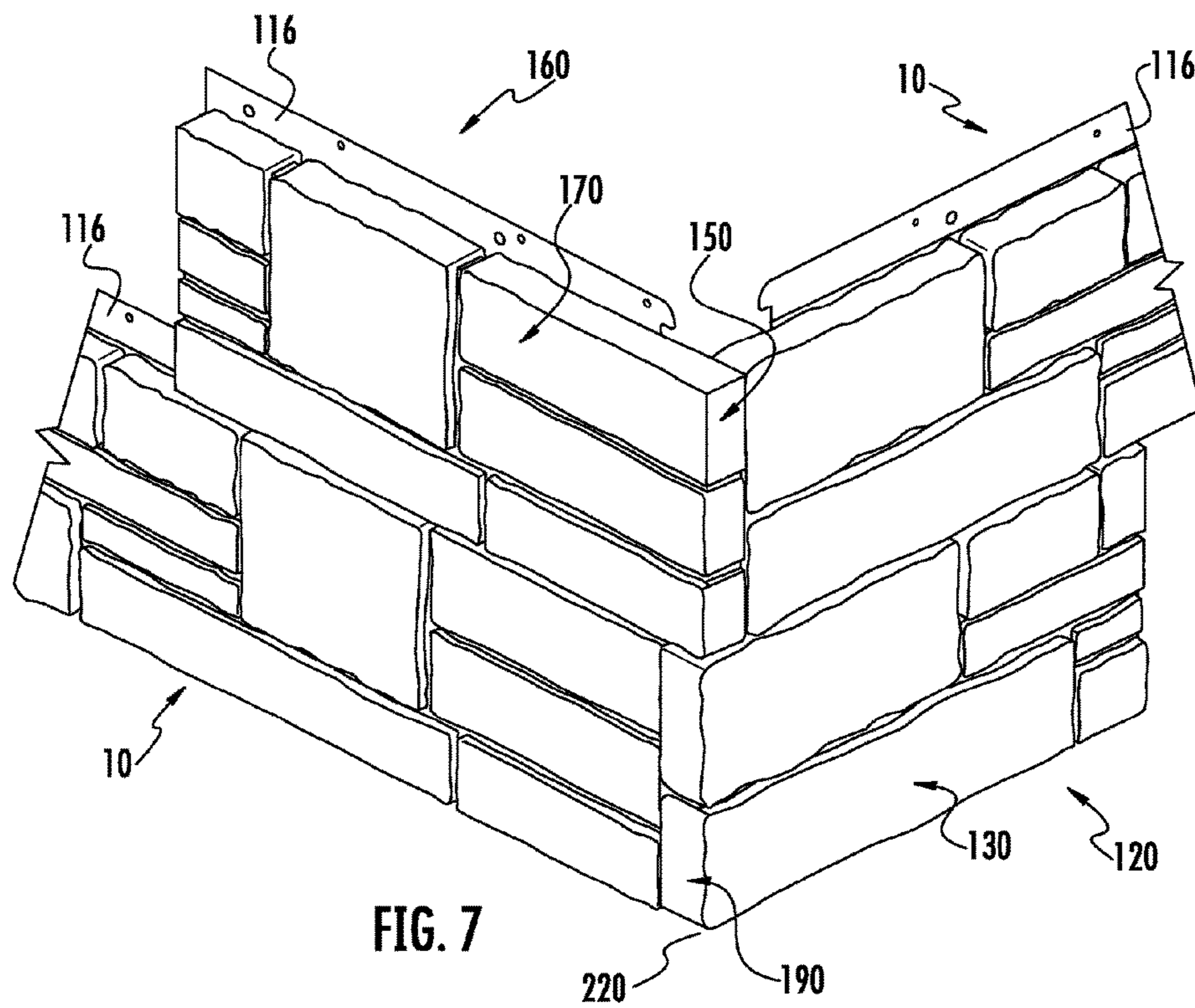

FIG. 6B



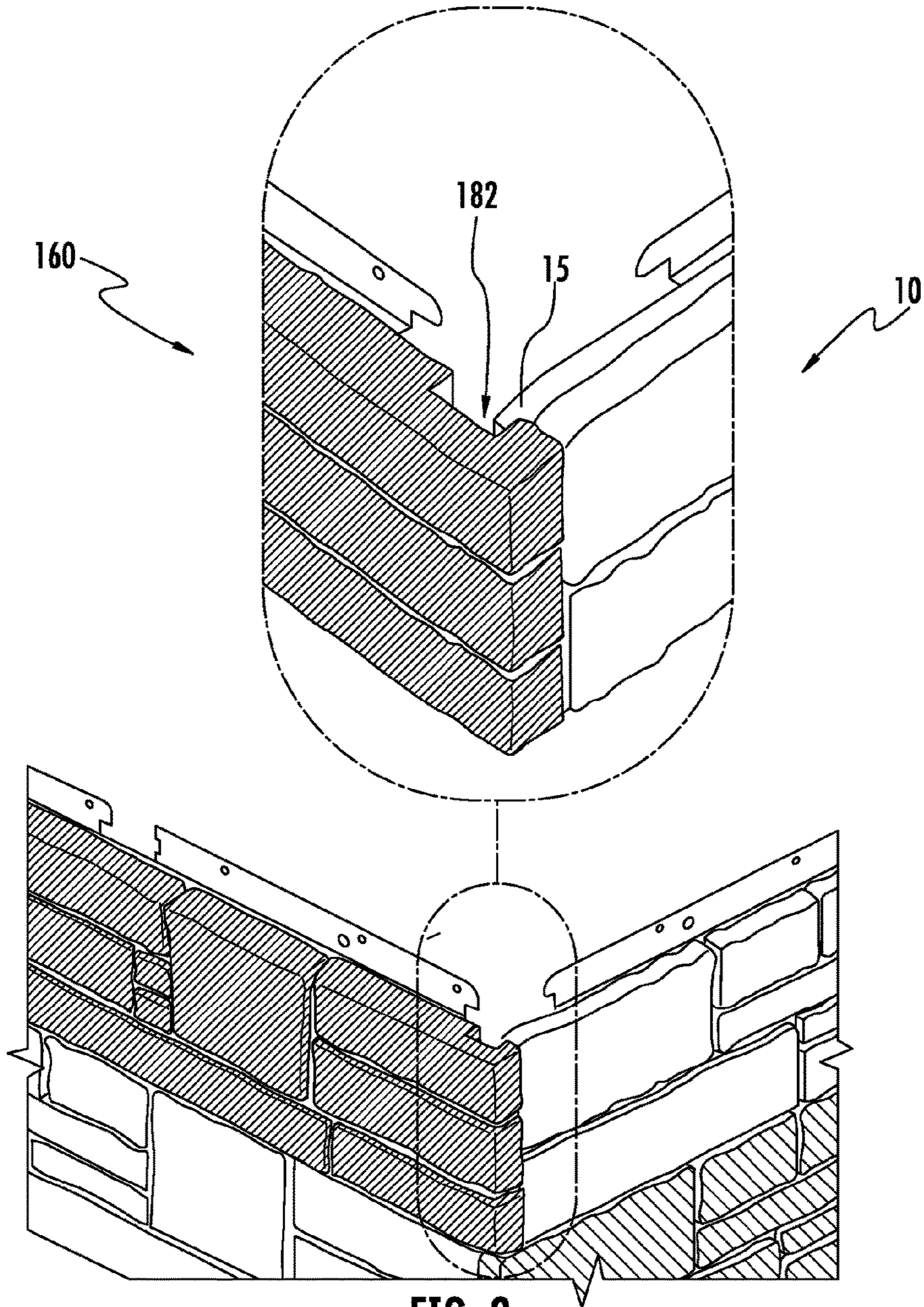
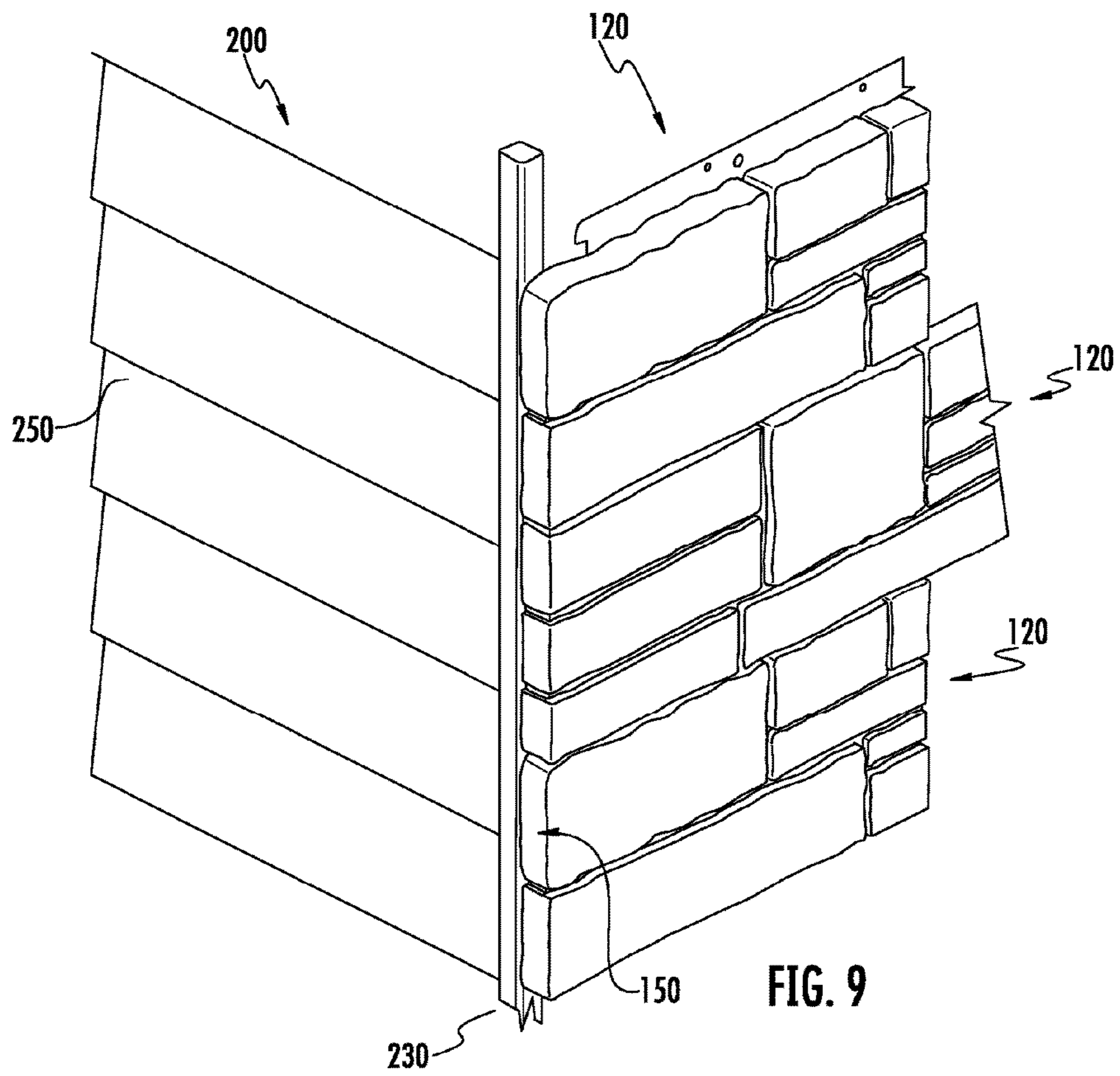
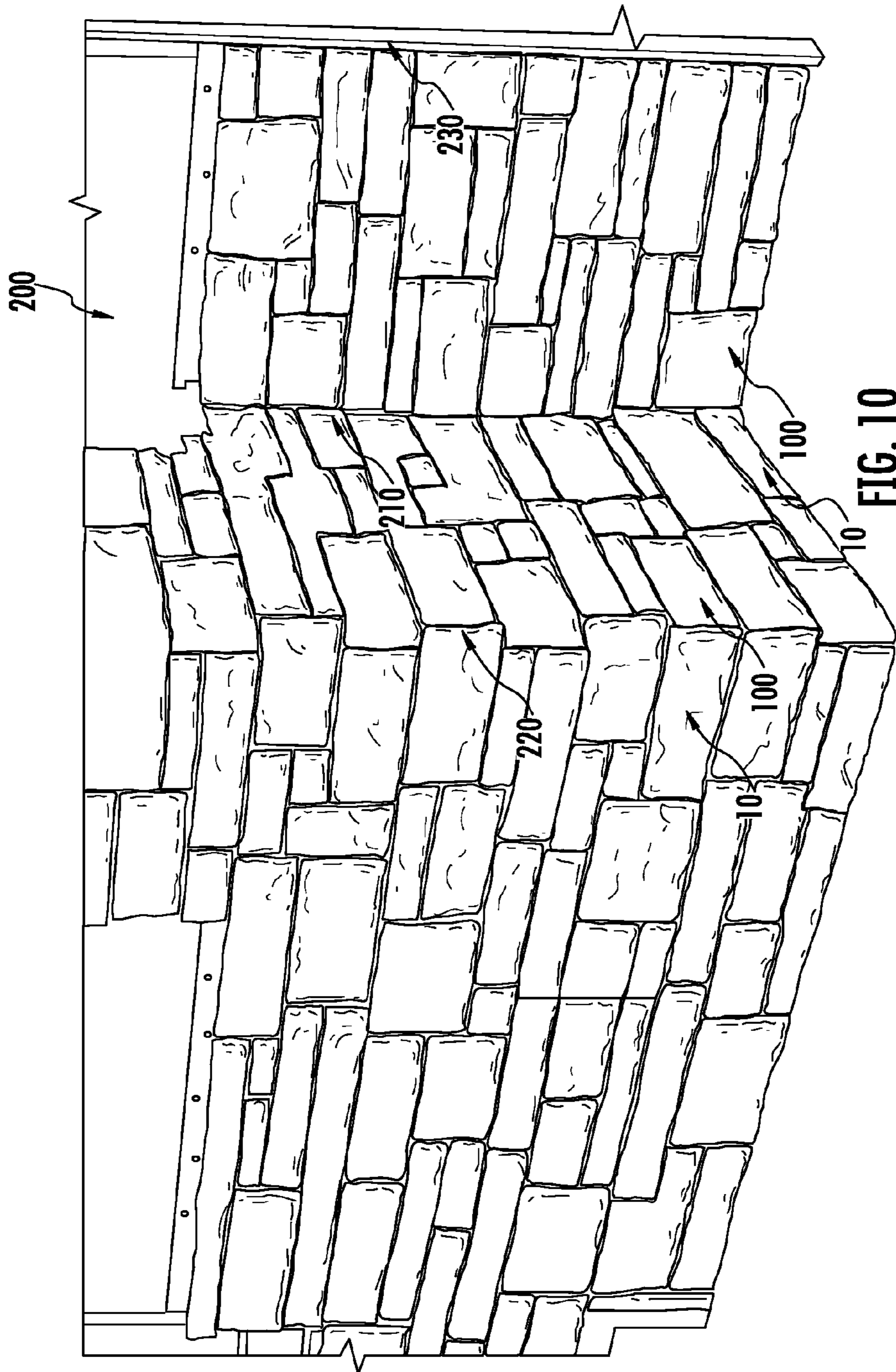

FIG. 8





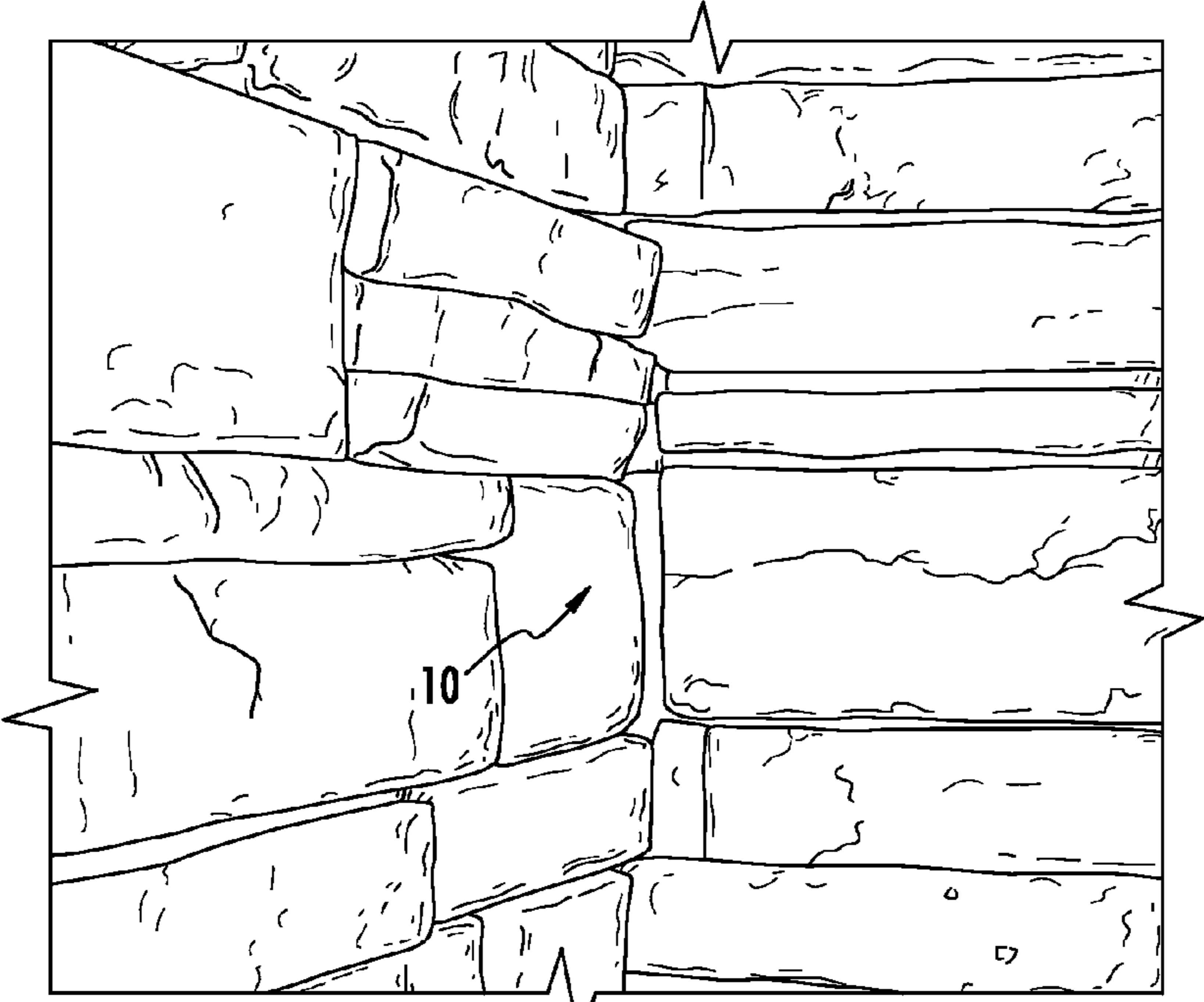

FIG. 11A

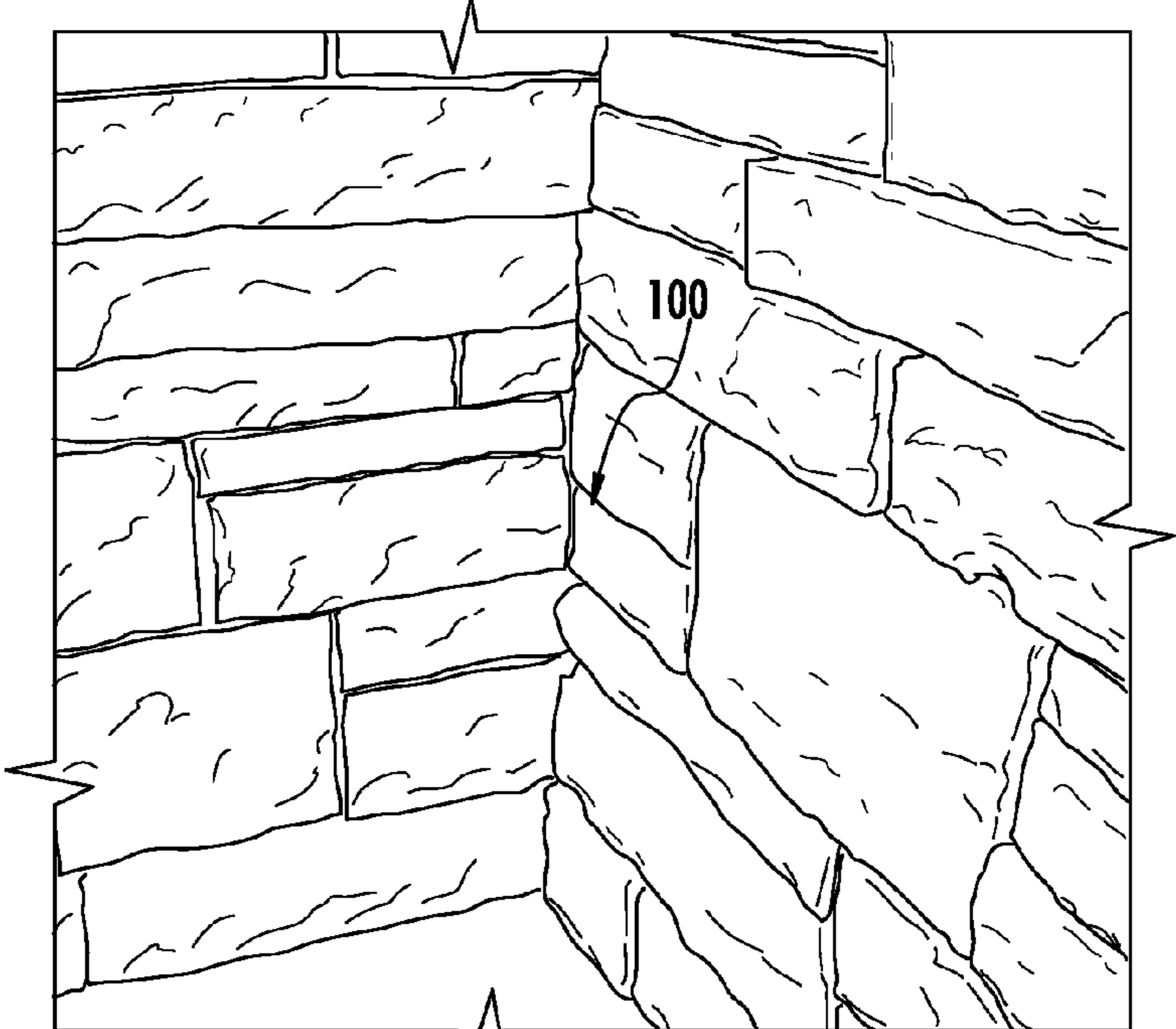

FIG. 11B

WALL PANEL

Matter enclosed in heavy brackets [] appears in the original patent but forms no part of this reissue specification; matter printed in italics indicates the additions made by reissue; a claim printed with strikethrough indicates that the claim was canceled, disclaimed, or held invalid by a prior post-patent action or proceeding.

BACKGROUND

In the construction of buildings, frequently used construction products include exterior cladding materials. Exterior cladding materials may be used to cover the exterior surfaces formed from various framing structures. Over the years, exterior cladding materials have been formed as prefabricated or cast veneer wall panels, which provide a quick and efficient way to provide a masonry appearance for a building while also simplifying construction and lowering cost. Non-limiting examples of exterior cladding materials that have been formed in this manner include stone veneer, brick veneer, aluminum siding, vinyl siding, wood siding, stucco, concrete, glass, and metal.

In certain applications, the exterior building cladding materials may be applied to more than one wall of various sub-structures, thereby necessitating materials or panels that are configured to efficiently and effectively turn the corners created between those walls, whether an outside or an inside oriented corner. Historically, designers and installers have solved problems associated with turning corners either by simply abutted various standard configured cladding materials or by using L-shaped corner panels. However, adapting standard configured cladding materials for corner use oftentimes resulted in undesirable imperfections and/or irregular gaps adjacent the intersection of such materials, due largely to their not being intended for such use. Similarly, while traditional L-shaped corner panels addressed such standard panel concerns, their use was oftentimes cumbersome and inefficient, particularly as many structural corners are not precisely and repeatedly L-shaped. Of course, traditional L-shaped corner panels only proved useful for outside-oriented corners, requiring continued adaptation of standard panels for inside-oriented corners.

Still further, in certain applications, it is oftentimes desirable to apply exterior building cladding materials along one or more walls of a sub-structure and, upon encountering an outside-oriented corner, switch to an alternate material (e.g., from stone veneer to vinyl siding). In such instances, an aesthetically pleasing termination of the exterior building cladding material is desirable. Traditionally, uniquely configured end pieces have been provided and used in such scenarios, in addition to the standard panels and/or L-shaped corner panels. As a result, installation of many cladding material systems becomes not only complex and cumbersome, but inefficient and costly, due in large part to the high level of manual labor and material waste inherently involved.

Thus, a need exists for an exterior cladding material corner panel that may be interchangeably used to address an outside-oriented corner, an inside-oriented corner, and an end wall termination. A need also exists for such a universal corner panel that eliminates the undesirable imperfections and/or irregular gaps created by using traditional panels and produce a wall having an enhanced aesthetic appearance.

BRIEF SUMMARY

In one embodiment, a universal corner panel comprises a first surface comprising a first portion and a second portion,

the first portion having a first surface topography with a first delta, the second portion having second surface topography with a second delta, the first delta being substantially different than the second delta.

In one embodiment, a universal corner panel comprises a first surface; a first portion located on the first surface, the first portion comprising at least one design portion defining a maximum thickness of the first portion and at least one design portion defining a minimum thickness of the first portion; and a second portion located on the first surface, the second portion comprising at least one design portion defining a maximum thickness of the second portion and at least one design portion defining a minimum thickness of the second portion, wherein a first difference between the maximum and the minimum thicknesses of the first portion is substantially greater than a second difference between the maximum and the minimum thicknesses of the second portion.

In one embodiment, a universal corner panel comprises a first surface; a central portion of the first surface, the central portion having a first surface topography; and two peripheral portions of the first surface, each of the two peripheral portions having a second surface topography, wherein the first surface topography is substantially different from the second surface topography.

Various advantages of this invention will become apparent to those skilled in the art from the following detailed description of the invention, when read in light of the accompanying drawings.

BRIEF DESCRIPTION OF THE DRAWINGS

The accompanying drawings incorporated herein and forming a part of the specification, illustrate several aspects of the present invention and together with the description serve to explain certain principles of the invention. In the drawings:

FIG. 1 is a front elevation view of a standard flat panel 10 for use in conjunction with various embodiments of the universal corner panel disclosed herein;

FIG. 2 is a front elevation view of a universal corner panel 100 according to various embodiments according to various embodiments;

FIG. 3A is a front elevation view of a first portion 120 of the universal corner panel 100 of FIG. 2 according to various embodiments;

FIG. 3B is a front elevation view of a second portion 160 of the universal corner panel 100 of FIG. 2 according to various embodiments;

FIG. 3C is a side elevation view of a side edge of a universal corner panel 100 analogous to that illustrated in FIG. 3A according to various embodiments;

FIG. 3D is a side elevation view of a side edge of a universal corner panel 100 analogous to that illustrated in FIG. 3A according to various embodiments;

FIG. 4 is a perspective view of the first portion 120 and the second portion 130 of the universal corner panel 100 of FIG. 2, as positioned relative to two standard flat panels 10 of FIG. 1, so as to form an exemplary inside corner 210 according to various embodiments;

FIG. 5 is rear elevation view of the universal corner panel 100 of FIG. 2 according to various embodiments;

FIG. 6A is a rear elevation view of the first portion 120 of the universal corner panel 100 of FIG. 2 according to various embodiments;

FIG. 6B is a rear elevation view of the second portion 130 of the universal corner panel 100 of FIG. 2 according to various embodiments;

FIG. 7 is a perspective view of the first portion 120 and the second portion 130 of the universal corner panel 100 of FIG. 2, as positioned relative to two standard flat panels 10 of FIG. 1, so as to form an exemplary outside corner 220 according to various embodiments;

FIG. 8 is an exploded perspective view of the second portion 130 of the universal corner panel 100 and one of the standard flat panels 10 of FIG. 7, further illustrating the positioning of a tongue 50 of the standard flat panel within a channel 150 of the universal corner panel according to various embodiments;

FIG. 9 is a perspective view of a plurality of first portions 120 of the universal corner panel 100 of FIG. 2, as positioned relative to a wall having an alternative cladding material 250, so as to form an exemplary end wall termination 230 according to various embodiments;

FIG. 10 is a perspective view of a plurality of standard flat panels 10 and universal corner panels 100 according to various embodiments, being used to form still further exemplary inside corners 210, outside corners 220, and end wall terminations 230;

FIG. 11A is a perspective view of an installation of the standard flat panel 10 in an exemplary inside corner 210 configuration; and

FIG. 11B is a perspective view of an installation of the universal corner panel 100 in an inside corner 210 substantially analogous to that of FIG. 11A.

Reference will now be made in detail to the various embodiments of the invention, examples of which are illustrated in the accompanying drawings.

DETAILED DESCRIPTION OF VARIOUS EMBODIMENTS

Referring now to FIG. 2, an exemplary embodiment of a universal corner panel is shown generally as 100. Generally, the universal corner panel 100 according to various embodiments is attached to an exterior framework of a building and configured to interface with one or more standard panels (see e.g., FIG. 1). Together, the universal corner panel 100 and the one or more standard panels provide a wall panel system of the type used as a wall cladding for a building. Further applications include, but are not limited to the construction of a fireplace surround or an outdoor living component, such as a decorative wall or grill surround. Embodiments of the universal corner panel may advantageously be used for inside corners, outside corners, and an end wall termination to provide an aesthetically pleasing corner.

Reference is now made to FIG. 2 illustrating a universal corner panel 100 according to various embodiments. As may be seen from this figure, the panel 100 according to various embodiments may be made from a cast material, such as concrete, reinforced concrete, gypsum, reinforced cementitious materials, geopolymers, pozzolanic materials and/or combinations thereof. Other embodiments are envisioned where the panel is made from polymeric materials, which may or may not be filled with inorganic materials. Further, as illustrated, the universal corner panel 100 may, in any of a variety of embodiments, include a grout field, sometimes also referred to as a mortar joint, (shown but not numbered), and/or a mounting flange 116, either of which may be configured in substantially the same manner, shape, and size to the standard panel 10 of FIG. 1. It should be understood,

of course, that each of these features are illustrated in an exemplary fashion and, as such, they may be alternatively configured or sized, as may be desirable for particular applications, without departing from the scope of the present invention.

The universal corner panel 100 according to various embodiments may further comprise a central portion 105, two peripheral portions 110, 112, and a plurality of design portions 139. As illustrated, the universal corner panel 100 may, in certain embodiments, be substantially rectangular in shape, although in other embodiments, the panel may be square or still otherwise shaped, as may be desirable for particular applications. Indeed, it should be understood that the length 102 and the height 104 of the panel 100 may be any of a variety of dimensions, as may be desirable for particular applications. In one embodiment, the mounting flange 116 is less than the length 102 of the panel, which advantageously allows the panel to be used to make an outside corner without the mounting flange 116 being visible.

The central portion 105 of the universal corner panel 100 according to various embodiments may have a length 106 that is to some degree less than the length 102 of the panel 100 in its entirety. Of course, it should be understood that in still other embodiments, the length 106 of the central portion 105 of the universal corner panel 100 may be any of a variety of lengths, as may be desirable for a particular application, provided such is to some degree less than the length 102 of the entire panel.

The central portion 105 of the universal corner panel 100 according to various embodiments may include a plurality of design portions 139. In certain embodiments, each of the design portions 139 may be configured to substantially resemble a plurality of natural stone elements. In other embodiments, however, the design portions 139 may not be configured so as to resemble individual stones, but rather a continuous surface of varying thicknesses. In still other embodiments, the design portions 139, whether individually or otherwise configured, may be formed so as to substantially resemble any of a variety of aesthetic masonry and/or cladding materials, as may be desirable for particular applications. However, in at least the illustrated embodiment of FIG. 2, each of the design portions 139 is configured as a separate design element, each resembling individual natural stones.

The design portions 139 of the central portion 105 according to various embodiments are configured with certain a first surface topography. The design portions 139 of the central portion 105 may, in certain embodiments, be formed with varying thicknesses (see e.g., FIGS. 3C-D), which collectively define a maximum and minimum thickness of the central portion 105. Such maximum and minimum thicknesses, in turn, define relative differences between the thicknesses of the design portions 139, which in turn define the above-described the surface topography. Such first surface topography of the design portions 139 of the central portion 105 contribute to a natural aesthetic appearance of the panel 100, namely by making it at least partially three-dimensional.

The two peripheral portions 110, 112 of the universal corner panel 100 according to various embodiments may have respective lengths 111, 113 that are not only less than the length 102 of the panel 100 in its entirety but also substantially less than the length 106 of the central portion 105. Of course, it should be understood that in still other embodiments, the lengths 111, 113 of the respective peripheral portions 110, 112 of the universal corner panel 100 may

5

be any of a variety of lengths, as may be desirable for a particular application, provided such is to some degree less than the length **102** of the entire panel.

It should be further noted that in any of the above described embodiments, and still other embodiments, the lengths **111**, **113** of the respective peripheral portions **110**, **112** of the universal corner panel **100** may be greater than or equal to a corresponding thickness of the standard panel **10** of FIG. **1**, which allows the standard panels **10** to be positioned relative to the corner panels **100**, and in particular the respective peripheral portions **110**, **112** thereof, without the standard panel abutting any portion of the central portion **105** of the corner panel.

The two peripheral portions **110**, **112** of the universal corner panel **100** according to various embodiments may likewise include a plurality of design portions **139**. The design portions **139** of the two peripheral portions **110**, **112** according to various embodiments may be likewise configured with a certain second surface topography. The design portions **139** of the two peripheral portions **110**, **112** may, in certain embodiments, be formed with varying thicknesses (see e.g., FIGS. **3C-D**), which collectively define a maximum and minimum thickness of the two peripheral portions **110**, **112**. Such maximum and minimum thicknesses, in turn, define relative differences between the thicknesses of the design portions **139**, which in turn define the second surface topography. In one embodiment, the first surface topography of the central portion **105** has a mean thickness greater than a mean thickness of the second surface topography of the two peripheral portions **110**, **112**, wherein the "mean thickness" value is determined by first identifying a maximum thickness and a minimum thickness in the respective portion and averaging the two thicknesses in the respective portion.

It should be understood that the second surface topography of the two peripheral portions **110**, **112** differ from those of the central portion **105** in various embodiments. Generally speaking, the second surface topography of the various portions may be such that the difference between the maximum and minimum thicknesses is smaller in the two peripheral portions **110**, **112** than in the central portion **105**, which advantageously enables positioning of a standard panel **10** (FIG. **1**) abutting the two peripheral portions **110**, **112** with such abutment resulting in minimal. In other words, the three-dimensional configuration of the central portion **105**, is minimal, relatively speaking, in the two peripheral portions **110**, **112**.

It should be further understood that the design portions **139** of the two peripheral portions **110**, **112** and/or the central portion **105** may not, according to various embodiments, be respectively confined solely to one or the other of the portions. In other words, in at least certain embodiments, one or more design portions **139** may be positioned such that one segment lies in at least one of the peripheral portions **110**, **112** and another segment lies in the central portion **105**. At least the two left-most design portions **139** illustrated in FIG. **2** are configured and positioned in precisely this manner. In certain embodiments, such "crossing" design portions **139** may have a taper in thickness between the central portion **105** and the at least one peripheral portion **110**, **112**. In other embodiments, the design portions **139** may contain a notch or other cut-out feature in at least one of the peripheral portion **110**, **112**, which advantageously eliminates the need for an installer to chip away the design portions **139** in the peripheral portion **110**, **112**. In yet other embodiments, the "crossing" design portions are configured to be relatively flat, i.e., the difference between a minimum and maximum thickness of the design portion is substan-

6

tially the same as the minimum and maximum thickness in the peripheral portion **110**, **112**.

Reference is now made to FIGS. **3A** and **3B**, illustrating a first cut segment **120** and a second cut segment **160** of the panel, as separated along a cut line **118** (see FIG. **2**). In these and other embodiments, it should be understood that the first cut segment **120** may have a length **122** and the second cut segment **160** may have a length **162**, the sum of the two lengths **122**, **162** being substantially the same as the length **102** of the panel in its entirety. Other embodiments are envisioned in which multiple cuts are made to create differing lengths for the first cut segment **120** and the second cut segment **160**. In other words, at least a portion of the central portion may be removed and discarded to create differing lengths of the first cut segment **120** and the second cut segment **160**.

According to various embodiments, the first cut segment **120** may also have a corresponding height **124**. In certain embodiments, the height **124** is substantially the same as a height (shown but not numbered) of the standard panel **10** of FIG. **1**. In this manner, the first cut segment **120** and corresponding standard panels **10** may be positioned relative to one another so as to form successively stacked "courses" or rows of panels about either inside-oriented or outside-oriented corners of a building structure **200** (see e.g., at least FIGS. **4**, **7**, and **10**).

The first cut segment **120** of the universal corner panel **100** may, according to various embodiments, comprise a first surface **130** having a first portion **131**, a second portion **135**, and a plurality of design elements **139**. In these and other embodiments, it should be understood that the first portion **131** may have a length **134** and the second portion **135** may have a length **138**, the sum of the two lengths **134**, **138** being substantially the same as the length **122** of the first cut segment **120** in its entirety.

It should be understood that the first portion **131** of the first cut segment **120** comprises a plurality of design portions or elements **139**. On the first portion **131**, according to various embodiments, the design portions **139** may be configured to have certain surface topography that create a natural aesthetic appearance, amongst other things. The surface topography of the first portion **131** are defined in these and other embodiments by a maximum thickness **132a** of the design portions **139** and a minimum thickness **132b** of the design portions, as may be best understood from FIG. **3C**. In certain embodiments, a particular individual design portion/element **139** may define the maximum thickness **132a**, while in other embodiments, namely those in which the design portions may not resemble individual elements, a thickest portion across the first portion **131** may define the maximum thickness. Analogous characteristics exist according to various embodiments for defining the minimum thickness **132b**.

Examining FIG. **3C** further, according to various embodiments it should be understood that the relative thicknesses **132a**, **132b** of the design portions in the first portion **131** may define a difference or delta **133** there-between. In certain embodiments, it is this delta **133**, as the greater the delta, the more three-dimensional and thus "decorative" the first surface **130** of the universal corner panel **100** becomes, while the lesser the delta, the less three-dimensional and more "flat" the first surface **130** becomes. In this manner, the first portion **131** will generally be configured according to various embodiments described herein with a decorative, "greater" three-dimensional structure than the second portion **135**. According to various embodiments, as may be

understood from FIG. 3C, the maximum thickness **132a** is generally less than or equal to the length **138** of the second portion **135**.

With reference now to FIG. 3A and referring specifically to the length **138** of the second portion **135** of the first cut segment **120**, it should be understood that the length **138** may be any of a variety of lengths, provided such is greater than or equal to a thickness of the standard panel **10**, which may be abutted adjacently thereto. It should also be understood that the length **138** of the second portion **135** corresponds approximately to the lengths **111**, **113** of at least one of the two peripheral portions **110**, **112**. According to various embodiments, the length **134** of the first portion **131** and the length **138** of the second portion **135** are not substantially equal relative to one another.

Referring still to FIG. 3A, it should be understood that the second portion **135** of the first cut segment **120** comprises a plurality of design portions or elements **139**. On the second portion **135**, according to various embodiments, the design portions **139** may be configured to have certain surface topography that not only create an aesthetic decorative appearance but also minimize gaps there-between when mounted in a corner (see e.g., FIG. 10). The surface topography of the second portion **135** are defined in these and other embodiments by a maximum thickness **136a** of the design portions **139** and a minimum thickness **136b** of the design portions, as may be best understood from FIG. 3C. In certain embodiments, a particular individual design portion/element **139** may define the maximum thickness **136a**, while in other embodiments, namely those in which the design portions may not resemble individual elements, a thickest portion across the second portion **135** may define the maximum thickness. Analogous characteristics exist according to various embodiments for defining the minimum thickness **136b**.

With reference now to at least FIGS. 3A and 3C, it should be understood that according to various embodiments, the design portions/elements **139**, may be configured to extend not only across substantially all or at least a portion of the first surface **130** of the first cut segment **120**, but also onto a side edge **150** of the first cut segment **120** that is substantially perpendicularly oriented relative to the first surface. In these and other embodiments, such facilitates use of the first cut segment **120** to end a wall surface without turning a corner, as illustrated in at least FIGS. 9 and 10.

Referring further to such figures, further in conjunction with FIG. 3A, it may be seen that, according to various embodiments, the design portions/elements **139** on the side edge **150** may comprise a certain surface topography, much like those located on the first surface **130**. Additionally, in one embodiment, side edge **150** is free of any cut-outs or visible channels, which advantageously forms an aesthetically pleasing outside corner. Indeed, in certain embodiments, a difference in thickness between at least two design portions/elements **139** located on the side edge **150** may similarly define a delta **152**, analogous to the deltas **133**, **137**. In this manner, the side edge **150**, which may function as an end wall face (see again FIG. 9) may, in certain embodiments, be configured with “decorative” surface topography as were the first and second portions **131**, **135**. In at least the illustrated embodiment, the delta **152** may be dimensioned substantially the same as the delta **133**; however, it should be understood that in other embodiments, the delta **152** may be dimensioned substantially the same as the delta **137** of the second portion **135**. In still other embodiments, the delta **152** may be still otherwise configured and

dimensioned, substantially different from both of the deltas **133**, **137**, as may be desirable for particular applications.

With reference now to FIG. 3B alone, the second cut segment **160** of the universal corner panel **100** may, according to various embodiments, comprise a first surface **170** having a first portion **171**, a second portion **175**, and a plurality of design portions/elements **179**, the latter of which are substantially the same as the design portions/elements **139**. In these and other embodiments, it should be understood that the first portion **171** may have a length **174** and the second portion **175** may have a length **178**, the sum of the two lengths **174**, **178** being substantially the same as the length **162** of the second cut segment **160** in its entirety.

Referring still to FIG. 3B, it should be understood that the first portion **171** of the second cut segment **160** comprises a plurality of design portions or elements **179**. On the first portion **171**, according to various embodiments, the design portions **179** may be configured to have certain surface topography that create a natural aesthetic appearance, amongst other things. The surface topography of the first portion **171** are defined in these and other embodiments by a maximum thickness **172a** of the design portions **179** and a minimum thickness **172b** of the design portions, as may be best understood from FIG. 3D. In certain embodiments, a particular individual design portion/element **179** may define the maximum thickness **172a**, while in other embodiments, namely those in which the design portions may not resemble individual elements, a thickest portion across the first portion **171** may define the maximum thickness. Analogous characteristics exist according to various embodiments for defining the minimum thickness **172b**.

Examining FIG. 3D further, according to various embodiments it should be understood that the relative thicknesses **172a**, **172b** of the design portions in the first portion **171** may define a difference or delta **173** there-between. In certain embodiments, it is this delta **173** that defines the surface topography, as the greater the delta, the more three-dimensional and thus “decorative” the first surface **170** of the second cut segment **160** of the universal corner panel **100** becomes, while the lesser the delta, the less three-dimensional and more “abutment-prone” the first surface becomes. In this manner, with regard to relative dimensions of the design portions **179**, the first portion **171** will generally be configured according to various embodiments described herein with a decorative, “greater” three-dimensional structure than the second portion **175**.

Remaining with FIG. 3D, it may be seen that the thicknesses **172a**, **172b** of the first portion **171** of the second cut segment **160** further define a difference or delta **173** there-between. Still further, it should be understood from viewing FIG. 3B in conjunction with FIG. 3D that one or more design portions/elements **179** may overlap across the first and second portions **171**, **175**, in which case the segment of the “crossing” elements that lie within the first portion **171** will be configured with surface topography (e.g., deltas **173**), while the segment of the “crossing” elements that lie within the second portion **175** will be configured with differing surface topography (e.g., deltas **177**).

It is also worth mentioning that according to various embodiments, as may be appreciated by viewing FIGS. 3A-D in conjunction with one another, the respective features of the second cut segment **160**, including but not limited to the length **178** of the second portion **175**, the delta **173** of the first portion **171**, the delta **177** of the second portion, the first surface **170**, and/or any combination of these or still other features may be configured such that they are substantially the same in shape, size, relative character-

istics, and the like as the length **138** of the second portion **135**, the delta **133** of the first portion **131**, the delta **137** of the second portion, the first surface **130**, and/or any combination of these or still other features of the first cut segment **120** illustrated in FIGS. **3A** and **3C**. Of course, it should be understood that in other embodiments, one or more of the above-referenced features or still other features may be configured substantially differently in the second cut segment **160** as compared to the first cut segment **120**, as may be desirable for particular applications.

Still further with reference to FIG. **3B**, according to various embodiments, the length **174** of the first portion **171** and the length **178** of the second portion **175** are not substantially equal relative to one another. It should be understood that the second portion **175** of the second cut segment **160** comprises a plurality of design portions or elements **179**. On the second portion **175**, according to various embodiments, the design portions **179** may be configured to have certain surface topography that not only create an aesthetic decorative appearance but also minimize gaps there-between when mounted in a corner (see e.g., FIG. **10**). The surface topography of the second portion **175** are defined in these and other embodiments by a maximum thickness **176a** of the design portions **179** and a minimum thickness **176b** of the design portions, as may be best understood from FIG. **3D**. In certain embodiments, a particular individual design portion/element **179** may define the maximum thickness **176a**, while in other embodiments, namely those in which the design portions may not resemble individual elements, a thickest portion across the second portion **175** may define the maximum thickness. Analogous characteristics exist according to various embodiments for defining the minimum thickness **176b**.

Examining FIG. **3D** further, according to various embodiments it should be understood that the relative thicknesses **176a**, **176b** of the design portions in the second portion **175** may define a difference or delta **177** there-between. In certain embodiments, it is this delta **177** that substantially defines the surface topography, as the greater the delta, the more three-dimensional and thus “decorative” the first surface **170** of the universal corner panel **100** becomes, while the lesser the delta, the less three-dimensional and more “abutment-prone” the first surface becomes. In this manner, the second portion **175** will generally be configured according to various embodiments described herein with a non-decorative, “lesser” three-dimensional structure than the first portion **171**.

Still further it should be understood from viewing FIG. **3B** in conjunction with FIG. **3D** that one or more design portions/elements **179** may overlap across the first and second portions **171**, **175**, in which case the segment of the “crossing” elements that lie within the second portion **175** will be configured with surface topography (e.g., deltas **177**) that are minimal compared to those located on the first portion. In this manner, the surface topography of the second portion **175** facilitate use of the universal corner panel **100** in inside-oriented corners, as illustrated in at least FIGS. **4**, **10**, and **11A-B**. Indeed, as may be seen from at least FIGS. **11A-B** in particular, the surface topography of the second portion **175** of the universal corner panel **100** results in a much more aesthetically pleasing installation as compared to that of the standard panel **10** that creates unsightly gaps (see FIG. **11A**) between adjacently positioned panels **10**.

Referring now to FIGS. **3C-D**, it should be understood that regardless of the various deltas **133**, **137**, **173**, **177**, the relative maximum thicknesses **132a**, **136a**, **172a**, **176a** and corresponding minimum thicknesses **132b**, **136b**, **172b**,

176b may be configured in any of a variety of fashions. However, in certain embodiments, the maximum thickness of the segment (e.g., either **120** or **160**) may occur in the first portion (e.g., “decorative” portion) thereof, while in other embodiments the maximum thickness may occur in the second portion (e.g., the “non-decorative” or “abutment” portion), depending in what may be desirable for particular applications. Across these and still other embodiments, however, it is the respective deltas **133**, **137**, **173**, **177** that define the “decorative” versus “non-decorative” surface topography, meaning that the direction of taper between the respective first and second portions may, in at least certain embodiments, be immaterial. As non-limiting examples, in at least one embodiment, the maximum thickness may occur in the first portion, with an overall thickness taper downward to a lesser thickness in the second portion, while in another embodiment, the maximum thickness may occur in the second portion, with an overall thickness taper downward toward the first portion. The respective deltas in the second portions (e.g., **137**, **177**) will generally always be less than the respective deltas in the first portions (e.g., **133**, **173**).

With reference now to at least FIGS. **3B** and **3D**, it should be understood that according to various embodiments, the design portions/elements **179** may be configured to extend not only across substantially all or at least a portion of the first surface **170** of the second cut segment **160**, but also onto a side edge **190** of the second cut segment **160** that is substantially perpendicularly oriented relative to the first surface. In these and other embodiments, such facilitates use of the second cut segment **160** (much like the first cut segment **120**) to end a wall surface without turning a corner, as illustrated in at least FIGS. **9** and **10**.

Referring further to such figures, further in conjunction with FIG. **3B**, it may be seen that, according to various embodiments, the design portions/elements **179** on the side edge **190** may comprise surface topography, much like those located on the first surface **170**. Indeed, in certain embodiments, a difference in thickness between at least two design portions/elements **179** located on the side edge **190** may similarly define a delta **192**, analogous to the deltas **173**, **177**. In this manner, the side edge **190**, which may function as an end wall face (see again FIG. **9**) may, in certain embodiments, be configured with “decorative” surface topography, as were the first and second portions **171**, **175**. In at least the illustrated embodiment, the delta **192** may be dimensioned substantially the same as the delta **173**; however, it should be understood that in other embodiments, the delta **192** may be dimensioned substantially the same as the delta **177** of the second portion **175**. In still other embodiments, the delta **192** may be still otherwise configured and dimensioned, substantially different from both of the deltas **173**, **177**, as may be desirable for particular applications.

It should be further understood that, according to various embodiments, the side edge **190** of the second cut segment **160** may be configured substantially the same in shape, size, or otherwise as the side edge **150** of the first cut segment **120**. Similarly, in these and other embodiments, the delta **192** may be configured substantially the same as the delta **152** of the side edge **150** of the first cut segment **120**. However, in still other embodiments, the side edges **150**, **190** and the deltas **152**, **192** may be entirely or at least in part substantially differently configured relative to one another, as may be desirable for particular applications.

With reference now to at least FIGS. **5-8**, it should be understood that the first cut segment **120** of the universal corner panel **100** may, according to various embodiments, further comprise a second surface **140** substantially opposite

11

to the first surface **130**. In certain embodiments, the second surface **140** may include at least a channel **142** and an intermediate portion **146**, the intermediate portion **146** being positioned substantially between the channel **142** and the side edge **150** of the first cut segment **120**.

As may be seen from FIG. 6A, the channel **142** may according to various embodiments extend substantially along the entirety of the height **104** (see FIG. 2) of the corner panel **100**. In certain embodiments, however, it should be understood [that] that a height **[185]** **145** of the channel may be less than the height **104** of the panel, provided such is nevertheless configured to substantially receive and interface with the tongue **15** (see FIG. 1) of an adjacently positioned standard panel **10** (see FIG. 1).

As may be seen remaining with FIG. 6A with reference to FIG. 1, the depth **143** may be any of a variety of dimensions, provided such substantially corresponds to the dimensions (e.g., a depth) of the tongue **15** of a corresponding standard panel **10** (see FIG. 2) such that the tongue **15** may be substantially fully received within the depth of the channel **142**. While not necessarily the case in all embodiments, for at least certain embodiments, the respective depths of the channel and tongue may be configured such that the former is at least a minimal degree larger than the former, so as to provide at least some clearance between the two for purposes of installation.

In still other embodiments, the width **144** may be any of a variety of dimensions, provided such substantially corresponds to the dimensions (e.g., a width) of the tongue **15** (FIG. 1) of a corresponding standard panel **10** (FIG. 1) such that the tongue **15** (FIG. 1) may be substantially received within the depth of the channel **142**. While not necessarily the case in all embodiments, for at least certain embodiments, the respective widths of the channel and tongue may be configured such that the former is at least a minimal degree larger than the former, so as to provide at least some clearance between the two for purposes of installation.

Remaining with FIG. 6A, it should be further understood that in various embodiments, the channel **142** may further define an intermediate portion **146** on the second surface **140** of the universal corner panel **100**. It should be noted though, that in at least certain embodiments, the surface of the intermediate portion **146** may be configured such that it is substantially smooth relative to the remainder of the second surface **140**. Such may facilitate installation by providing a substantially planar surface, which minimizes gaps between successive panels.

With reference now to at least FIGS. 5-8, it should be understood that the second cut segment **160** of the universal corner panel **100** may, according to various embodiments, further comprise a second surface **180** substantially opposite to the first surface **170**. In certain embodiments, the second surface **180** may include at least a channel **182** and an intermediate portion **186**, the intermediate portion **186** being positioned substantially between the channel **182** and the side edge **190** of the second cut segment **160**.

As may be seen from FIG. 6B, the channel **182** may according to various embodiments extend substantially along the entirety of the height **104** (see FIG. 2) of the corner panel **100**. In certain embodiments, however, it should be understood that a height **185** of the channel may be less than the height **104** of the panel, provided such is nevertheless configured to substantially receive and interface with the tongue **15** (see FIG. 1) of an adjacently positioned standard panel **10** (see FIG. 1).

As may be seen remaining with FIG. 6B, the channel **182** may according to various embodiments have a depth **183**

12

substantially corresponding to the dimensions (e.g., a depth) of the tongue **15** (see FIG. 1) of a corresponding standard panel **10** (see FIG. 1) such that the tongue **15** (See FIG. 1) may be substantially fully received within the depth of the channel **182**. While not necessarily the case in all embodiments, for at least certain embodiments, the respective depths of the channel and tongue may be configured such that the former is at least a minimal degree larger than the former, so as to provide at least some clearance between the two for purposes of installation.

According to various embodiments, the channel **182** of FIG. 6B may also have a width **184**, which may be any of a variety of dimensions, provided such substantially corresponds to the dimensions (e.g., a width) of the tongue **15** (see FIG. 1) of a corresponding standard panel **10** (see FIG. 1) such that the tongue **15** (see FIG. 1) may be substantially received within the depth of the channel **182**. While not necessarily the case in all embodiments, for at least certain embodiments, the respective widths of the channel and tongue may be configured such that the former is at least a minimal degree larger than the former, so as to provide at least some clearance between the two for purposes of installation.

Remaining with FIG. 6B, it should be further understood that in various embodiments, the channel **182** may further define an intermediate portion **186** on the second surface **180** of the universal corner panel **100**. Of course, it should be understood that any of a variety of widths **187** may be incorporated, as may be desirable for particular applications. It should be noted though, that in at least certain embodiments, the surface of the intermediate portion **186** may be configured such that it is substantially smooth relative to the remainder of the second surface **180**. Such may facilitate installation by providing a substantially planar surface, which minimizes gaps between successive panels.

According to various embodiments, the universal corner panel **100** described herein may be formed in any of a variety of ways, as commonly known and understood in the art. In certain embodiments, the panel **100** may be manufactured by an open face molding process. To practice such a process, an initial layer of material is first applied to an open face mold having cavities therein with shapes simulating exterior cladding materials (e.g., stone, brick, or the like). Next, a layer of reinforcing material may optionally be applied over the initial layer. In certain embodiments, the process may involve overlaying a mold insert configured to form the channels **142**, **182**, as may be desirable for particular applications. In at least one of such embodiments, the mold insert may be configured so as to not only form the channels **142**, **182**, but also to form the substantially smooth surface area of the intermediate portions **146**, **186** of the second surfaces **140**, **180**.

In various embodiments, the molded material is allowed to cure and set before being removed from the mold. Upon removal, however, according to certain embodiments, the universal corner panel **100** comprises an ornamental facing layer formed from the cast molded material, such that the facing layer resembles a desirable exterior cladding material (e.g., stone, brick, or the like).

Of course, it should be understood that any of a variety of processes may be used to form the universal corner panel **100** depending on the material employed to make the universal corner panel **100**. Further processes may, in other embodiments, include compression or injection molding processes, blow mold or extrusion processes, and the like.

In one embodiment, the universal panel **100** is installed in combination with the standard panel **10** to form a wall

13

system. The standard panel **10** may, in certain embodiments be generally described as comprising a precast body including at least one decorative design element **12**. For purposes of disclosure, the terminology “standard panel” is to be given the broadest possible interpretation and covers any type of panel that is not an insert panel. In at least the illustrated embodiment of FIG. **1** each design element **12** comprises a single, variable-sized textured stone and the standard panel **10** comprises eleven stone-shaped design elements **12** positioned across two, three, and/or four rows, depending on the respective sizes of the elements **12**. The standard panel **10** may also, in certain embodiments, also include a grout field **14** for receiving and holding grout that outlines the respective design elements **12** so as to provide a desired masonry appearance. In various embodiments, the standard panel **10** may further include a tongue **15** configured to substantially interlock with adjacently positioned panels, as will be described in further detail below. In certain embodiments, the tongue **15** may be selectively removable, whether detachably so or by force applied thereto, again as will be described in further detail below. The standard panel **10** according to various embodiments may also include a mounting flange **16**.

In various applications, the veneer wall panel systems described herein may be installed via any of a number of methods, including the non-limiting example of the method described in further detail in U.S. Patent Application Pub. No. 2011/0239578 (“the ’578 application), commonly owned with the present application and hereby incorporated herein in its entirety.

For installation as an outside-oriented corner **220**, as illustrated in at least FIGS. **7** and **10**, as an initial step, the installer may start at a bottom of a wall and position either a first cut segment **120** or a second cut segment **160** into the trim strip with its mounting flange **116** oriented upward. A standard panel **10** may then be placed into the same trip strip on the adjacently oriented wall. The installer should, according to various embodiments, slide the universal corner panel **100** such that it extends slightly beyond the wall edge, such that the tongue **15** of the standard panel interfaces with the channel **142**, **182** of the corner panel. The outside-oriented corner **220** appearance may then be fine-tuned with slight adjustments of both panels **10**, **100** relative to one another until the best fit is achieved.

As may be seen with continued reference to at least FIG. **7**, the universal corner panel **100** should be used in an alternating fashion on respective courses of a panel installation. As a non-limiting example, following the installation of either a first or second cut segment **120**, **160**, if a first cut segment **120** was installed in the first course (e.g., adjacent the trim strip), a second cut segment **160** should be installed in the second course, but on the opposing side of the outside-oriented corner **220**. In other words, for installation of a second (or subsequent) course of panels about an outside-oriented corner **220**, the installer would first position (continuing with our non-limiting example) the second cut segment **160** atop the standard panel **10** previously installed in the first course. The installer would then position another standard panel **10** in the second course, immediately atop the first cut segment **120** positioned in the first course. The second cut segment **160** and the second standard panel **10** would be interfaced by receiving the tongue **15** of the panel **10** into the channel **182** of the corner panel **100** (see also FIG. **8**, close-up view of this interlocking feature).

For installation as an inside-oriented corner **210**, as illustrated in at least FIGS. **4** and **10**, the installer proceeds to form an “alternating” set of courses. However, instead of

14

interfacing a tongue of a standard panel **10** with a channel on the corner panel **100**, the “non-decorative” portion **135**, **175** (also known and described as peripheral portions **110**, **112** herein) are positioned such that a side edge of an adjacently positioned standard panel substantially abuts the first surface of those portions. Due to the desirable surface topography of these portions, installation of the corner panel **100** in an inside-oriented corner results in substantially minimal, if any, gaps, as previously encountered with installations of the prior art. Such is evident from at least FIGS. **11A** and **11B**, when considered relative to one another.

Returning to FIG. **4**, the universal corner panel **100** should be used in an alternating fashion on respective courses of an inside-oriented corner panel installation. As a non-limiting example, following the installation of a first cut segment **120** in a first course (e.g., adjacent the trim strip), a second cut segment **160** should be installed in a second course, but on the opposing side of the inside-oriented corner **210**. In other words, for installation of a second (or subsequent) course of panels about an inside-oriented corner **210**, the installer would first position (continuing with our non-limiting example) the second cut segment **160** atop the standard panel **10** previously installed in the first course. The installer would then position another standard panel **10** in the second course, immediately atop the first cut segment **120** positioned in the first course. The second cut segment **160** and the second standard panel **10** would be interfaced by abutting an end portion of the standard panel **10** substantially adjacent the “non-decorative” portions of the corner panel **100**. It should be understood, of course, that in certain embodiments, such will require an installer, prior to positioning to remove the tongue **15** of the standard panel adjacent the abutting side edge, whether via passive removing or a more forcible removal thereof.

Turning now to FIG. **9**, with reference also to FIG. **10**, it should be understood that the universal corner panel **100** according to various embodiments may further be configured for use in terminating a wall installation without turning an encountered corner, whether inside or outside-oriented in nature. In FIG. **9**, in the context of the non-limiting example of an outside-oriented corner, it may be seen that a plurality of first cut segments **120** are stacked sequentially atop one another, such that their respective side edges **150** form an aesthetically pleasing decorative “end wall” (versus a flat, nondescript edge as would be achieved with the standard panel **10** of at least FIG. **1**). It should be understood that while an end wall termination such as that in FIG. **9** utilizes only first cut segments **120**, an opposing directional termination, such as that illustrated in FIG. **10**, would use only second cut segments **160**.

It should be understood that while installation of the universal corner panel **100** has been described herein with reference to certain non-limiting examples of outside-oriented corners, inside-oriented corners, and end wall terminations, the panel may be used and/or installed in any of a variety of manners and in any of a variety of contexts, all as may be desirable for particular applications and practical for use with the structural and surface topography of the various portions of the panel **100**.

The foregoing description of the various embodiments of the present invention has been presented for purposes of illustration and description. It is not intended to be exhaustive or to limit the invention to the precise form disclosed. Obvious modifications or variations are possible in light of the above teachings. The embodiments were chosen and described to provide the best illustration of the principles of the invention and its practical application to thereby enable

15

one of ordinary skill in the art to utilize the invention in various embodiments and with various modifications as are suited to the particular use contemplated. All such modifications and variations are within the scope of the invention as determined by the appended claims when interpreted in accordance with the breadth to which they are fairly, legally and equitably entitled. The drawings and preferred embodiments do not and are not intended to limit the ordinary meaning of the claims in their fair and broad interpretation in any way.

What is claimed is:

1. A panel, the panel comprising:

a first surface having a central portion and at least two peripheral portions adjacent opposite sides of the central portion;

a second surface that is opposite and in a plane substantially parallel to the first surface, the first and second surfaces defining two opposing and spaced apart side edges of the panel;

the central portion having a first surface topography defined by a first plurality of design elements, the first surface topography defining a first change in thickness among the design elements of the central portion, the first change in thickness being a difference between a maximum thickness of a thickest one of the design elements of the central portion and a minimum thickness of a thinnest one of the design elements of the design elements of the central portion, wherein the thickness is measured from the first surface of the panel to a distal surface of each design element along an axis that is substantially perpendicular to the first and second surfaces; and

each of the two peripheral portions having a second and third surface topography, respectively, wherein the second surface topography is defined by a second plurality of design elements and the third surface topography is defined by a third plurality of design elements, the second and third surface topographies being substantially similar, the second surface topography defining a second change in thickness among the design elements of the second plurality of design elements, the second change in thickness being a difference between a maximum thickness of a thickest one of the second plurality of design elements and a minimum thickness of a thinnest one of the second plurality of design elements, and the third surface topography defining a third change in thickness among the design elements of the third plurality of design elements, the third change in thickness being a difference between a maximum thickness of a thickest one of the third plurality of design elements and a minimum thickness of a thinnest one of the third plurality of design elements,

wherein the first surface topography is substantially different from the second and third surface topographies and the first change in thickness is substantially greater than the second change in thickness, and

wherein the design elements extend outwardly from the first surface.

2. The panel of claim 1, further comprising:

at least two elongate channels defined in respective portions of the second surface opposing the second and third plurality of design elements of the first surface, wherein:

each of the elongate channels extends substantially adjacent and parallel to a respective one of the two side edges of the panel.

16

3. A panel, the panel comprising:

a precast body comprising:

a first surface having a first portion[,] and a second portion[, and a third portion],

a second surface that is opposite and in a plane substantially parallel to the first surface;

the first portion comprising a first plurality of design elements, at least one design element of the first plurality having a maximum thickness of the first plurality and at least one design element of the first plurality having a minimum thickness of the first plurality; and

the second portion comprising a second plurality of design elements, at least one design element of the second plurality having a maximum thickness of the second plurality and at least one design element of the second plurality having a minimum thickness of the second plurality[; and

the third portion comprising a third plurality of design elements, at least one design element of the third plurality having a maximum thickness of the third plurality and at least one design element of the third plurality having a minimum thickness of the third plurality.]

wherein:

the design elements extend outwardly from the first surface,

the thicknesses are measured from the first surface to a distal surface of each design element along an axis that is substantially perpendicular to the first and second surfaces, and

a first edge of the first portion [is centrally disposed between the second portion and the third portion,] abuts a first edge of the second portion and

a first difference between the maximum and the minimum thicknesses of the first portion is substantially greater than a second difference between the maximum and the minimum thicknesses of the second portion [and a third difference between the maximum and the minimum thicknesses of the third portion].

4. The panel of claim 3, further comprising a mounting element including a first end embedded in the precast body and a second end projecting from the precast body, wherein the mounting element has a length less than a total length of the precast body.

5. The panel of claim 3, wherein:

at least one design element is disposed on the first surface such that the at least one design element extends between the first and the second portions.

6. The panel of claim 3, further comprising:

the first and second surfaces defining at least one side edge of the panel; and

an elongate channel defined in a portion of the second surface opposing the second portion of the first surface, wherein:

the elongate channel extends substantially adjacent and parallel to the at least one side edge of the panel.

7. The panel of claim 3, further comprising:

at least one side edge of the panel extending between the first surface and the second surface adjacent the second portion of the panel,

wherein:

a first design element of the second portion has a lateral portion having a first length as measured from the side edge to a distal edge of the first design element along an axis that extends parallel to the first and the second surfaces and a second design element of the second portion has a lateral portion having a second

17

length that extends from the side edge to a distal edge of the second design element along the axis that extends parallel to the first and the second surfaces, the first length is a maximum length of the lateral portions of the design elements of the second portion and the second length is a minimum length of the lateral portions of the design elements of the second portion, and

a third difference between the first and the second lengths of the lateral portions of the design elements extending from the side edge is substantially greater than the second difference in thickness.

8. The panel of claim 1, further comprising a mounting element extending outwardly from an upper surface of the central portion of the panel, the upper surface extending between the first surface and the second surface within a plane that is substantially perpendicular to the first and second surfaces, wherein the mounting element has a length less than a total length of the central and the at least two peripheral portions.

9. The panel of claim 1, wherein at least one design element is disposed on the first surface such that the at least

18

one design element extends between the central portion and one of the at least two peripheral portions.

10. The panel of claim 9, wherein a thickness of the at least one design element tapers from the central portion to the peripheral portion.

11. The panel of claim 5, wherein a thickness of the at least one design element tapers from the first portion to the second portion.

12. *The panel of claim 3, wherein the first surface further comprises a third portion, the third portion comprising a third plurality of design elements, at least one design element of the third plurality having a maximum thickness of the third plurality and at least one design element of the third plurality having a minimum thickness of the third plurality, wherein the first portion is disposed centrally between the second portion and the third portion, and the first difference between the maximum and the minimum thicknesses of the first portion is substantially greater than a third difference between the maximum and the minimum thicknesses of the third portion.*

* * * * *