



US00RE47470E

(19) **United States**
(12) **Reissued Patent**
Hovda et al.

(10) **Patent Number: US RE47,470 E**
(45) **Date of Reissued Patent: Jul. 2, 2019**

- (54) **VERTEBRAL BODY PLACEMENT AND METHOD FOR SPANNING A SPACE FORMED UPON REMOVAL OF A VERTEBRAL BODY**
- (71) Applicant: **Simplify Medical Pty Ltd**, Paddington (AU)
- (72) Inventors: **David Hovda**, Mountain View, CA (US); **Yves Arramon**, Sunnyvale, CA (US)
- (73) Assignee: **Simplify Medical Pty Ltd** (AU)
- (21) Appl. No.: **15/191,385**
- (22) Filed: **Jun. 23, 2016**

Related U.S. Patent Documents

Reissue of:

- (64) Patent No.: **8,758,441**
- Issued: **Jun. 24, 2014**
- Appl. No.: **12/255,737**
- Filed: **Oct. 22, 2008**

U.S. Applications:

- (60) Provisional application No. 60/981,665, filed on Oct. 22, 2007.

- (51) **Int. Cl.**
A61F 2/44 (2006.01)
A61F 2/30 (2006.01)
A61B 17/86 (2006.01)

- (52) **U.S. Cl.**
CPC *A61F 2/30771* (2013.01); *A61F 2/4465* (2013.01); *A61B 17/86* (2013.01);
(Continued)

- (58) **Field of Classification Search**
None
See application file for complete search history.

(56) **References Cited**

U.S. PATENT DOCUMENTS

- 3,867,728 A 2/1975 Stubstad et al.
- 4,309,777 A 1/1982 Patil
- (Continued)

FOREIGN PATENT DOCUMENTS

- DE 3023353 A1 4/1981
- DE 3023353 A1 4/1981
- (Continued)

OTHER PUBLICATIONS

Chadwick et al., Radiolucent Structural Materials for Medical Applications, Jun. 1, 2001, MDDI, p. 1, http://www.mddionline.com/article/radiolucent-structural-materials-medical-applications.*

(Continued)

Primary Examiner — Cary E Wehner

(74) *Attorney, Agent, or Firm* — Wilson Sonsini Goodrich & Rosati

(57) **ABSTRACT**

A vertebral body replacement includes first and second end plates, and a compliant connector section between the end plates having one or more helical cuts to provide limited compliance between the end plates. The compliant connector section can be provided in a separate spacer that fits between the end plates or directly in one or more of the end plates. The adjoining end plate surfaces, and/or adjoining surfaces of the spacer, include a rotational interlock to inhibit rotational motion between the surfaces and allow a modular stacking assembly of the vertebral body replacement to accommodate a wide range of patients.

27 Claims, 4 Drawing Sheets

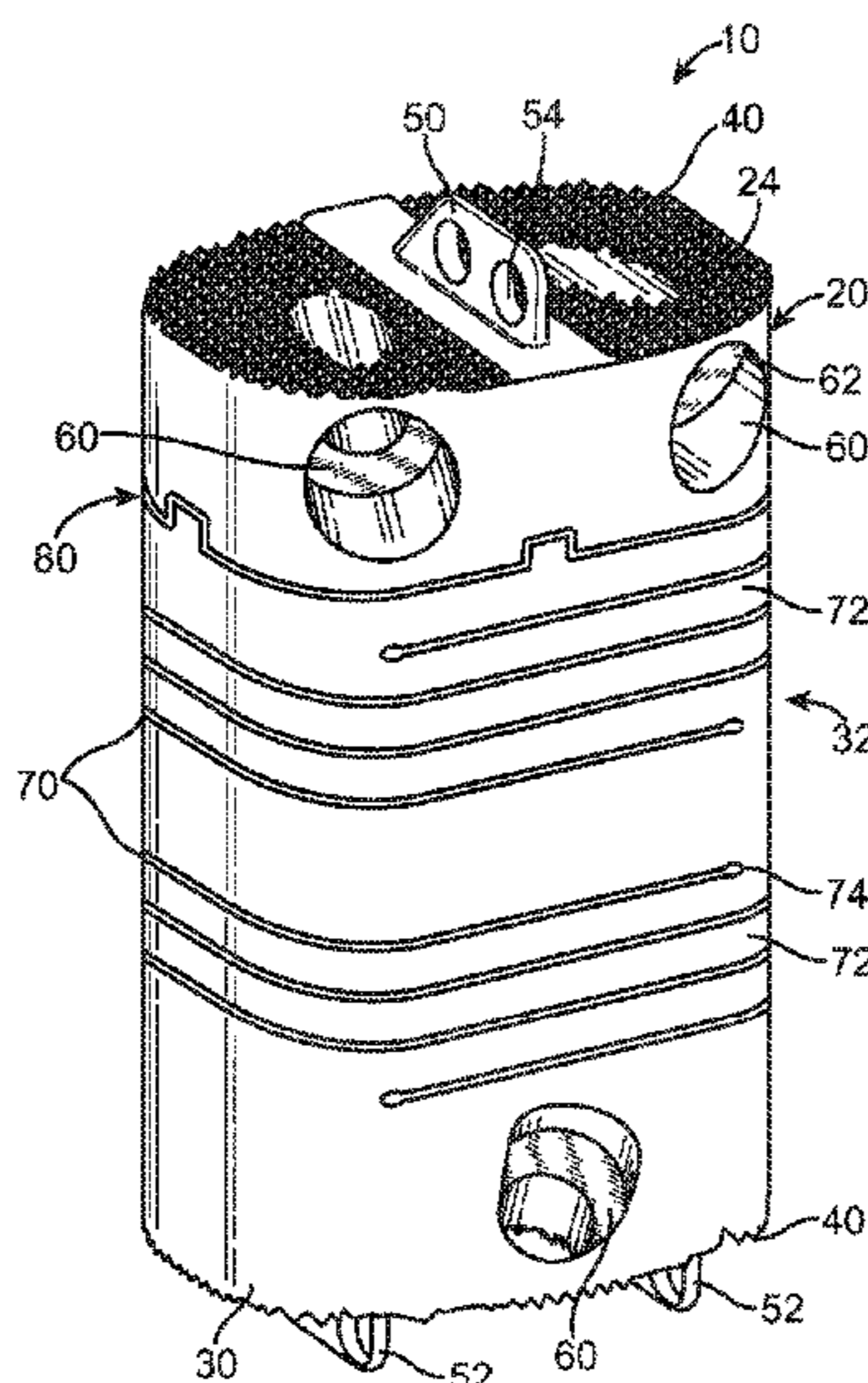

(52) **U.S. Cl.**
 CPC A61F 2002/30056 (2013.01); A61F 2002/30772 (2013.01); A61F 2002/30787 (2013.01); A61F 2002/30884 (2013.01); A61F 2002/30889 (2013.01); A61F 2002/30904 (2013.01); A61F 2002/449 (2013.01); A61F 2250/0032 (2013.01); A61F 2310/0088 (2013.01); A61F 2310/00407 (2013.01); A61F 2310/00431 (2013.01); A61F 2310/00604 (2013.01); A61F 2310/00796 (2013.01); A61F 2310/00976 (2013.01)

(56) **References Cited**

U.S. PATENT DOCUMENTS

4,531,917 A	7/1985	Linkow et al.	6,001,130 A	12/1999	Bryan et al.
4,566,466 A	1/1986	Ripple et al.	6,019,792 A	2/2000	Cauthen
4,619,660 A	10/1986	Christiansen et al.	6,022,376 A	2/2000	Assell et al.
4,673,407 A	6/1987	Martin	6,039,761 A	3/2000	Li et al.
4,759,766 A	7/1988	Buttner-Janz et al.	6,039,763 A	3/2000	Shelokov
4,759,769 A	7/1988	Hedman et al.	6,080,155 A	6/2000	Michelson
4,834,757 A	5/1989	Brantigan	6,083,228 A	7/2000	Michelson
4,863,477 A	9/1989	Monson	6,086,613 A	7/2000	Camino et al.
4,904,261 A	2/1990	Dove et al.	6,096,038 A	8/2000	Michelson
4,917,704 A	4/1990	Frey et al.	6,106,557 A *	8/2000	Robioneck et al. 623/17.15
4,932,969 A	6/1990	Frey et al.	6,132,465 A	10/2000	Ray et al.
4,946,378 A	8/1990	Hirayama et al.	6,136,031 A	10/2000	Middleton
4,997,432 A *	3/1991	Keller 623/17.11	6,139,551 A	10/2000	Michelson et al.
5,035,716 A	7/1991	Downey	6,139,579 A	10/2000	Steffee et al.
5,057,108 A	10/1991	Shetty et al.	6,143,033 A	11/2000	Paul et al.
5,071,437 A	12/1991	Steffee	6,146,421 A	11/2000	Gordon et al.
5,122,130 A	6/1992	Keller	6,156,067 A	12/2000	Bryan et al.
5,192,327 A *	3/1993	Brantigan 623/17.11	6,159,211 A *	12/2000	Borioni et al. 606/279
5,195,526 A	3/1993	Michelson	6,159,214 A	12/2000	Michelson
5,258,031 A	11/1993	Salib et al.	6,162,252 A	12/2000	Kuras et al.
5,282,861 A	2/1994	Kaplan	6,174,311 B1	1/2001	Branch et al.
5,306,308 A	4/1994	Gross et al.	6,176,881 B1	1/2001	Schar et al.
5,314,477 A	5/1994	Marnay	6,193,757 B1	2/2001	Foley et al.
5,320,644 A	6/1994	Baumgartner	6,224,595 B1	5/2001	Michelson
5,370,697 A	12/1994	Baumgartner	6,224,607 B1	5/2001	Michelson
5,394,457 A	2/1995	Leibinger et al.	6,231,609 B1	5/2001	Mehdizadeh
5,401,269 A	3/1995	Buttner-Janz et al.	6,235,030 B1	5/2001	Zucherman et al.
5,415,704 A	5/1995	Davidson	6,261,296 B1	7/2001	Aebi et al.
5,423,816 A *	6/1995	Lin 606/247	6,264,695 B1	7/2001	Stoy
5,458,642 A	10/1995	Beer et al.	6,290,726 B1	9/2001	Pope et al.
5,462,575 A	10/1995	Del Corso	6,296,664 B1	10/2001	Middleton
5,484,437 A	1/1996	Michelson	6,315,797 B1 *	11/2001	Middleton 623/17.16
5,489,307 A	2/1996	Kuslich et al.	6,322,567 B1	11/2001	Mittelstadt et al.
5,505,732 A	4/1996	Michelson	6,336,941 B1	1/2002	Subba Rao et al.
5,507,816 A	4/1996	Bullivant	6,348,071 B1	2/2002	Steffee et al.
5,534,030 A	7/1996	Navarro et al.	6,368,350 B1	4/2002	Erickson et al.
5,556,431 A	9/1996	Buttner-Janz	6,368,351 B1	4/2002	Glenn et al.
5,674,296 A	10/1997	Bryan et al.	6,375,681 B1	4/2002	Truscott
5,676,701 A	10/1997	Yuan et al.	6,375,682 B1	4/2002	Fleischmann et al.
5,676,702 A	10/1997	Ratron	6,395,032 B1	5/2002	Gauchet
5,683,465 A	11/1997	Shinn et al.	6,402,785 B1	6/2002	Zdeblick et al.
5,702,450 A	12/1997	Bisserie	6,409,766 B1	6/2002	Brett
5,709,683 A	1/1998	Bagby	6,413,278 B1	7/2002	Marchosky
5,728,159 A	3/1998	Stroeve et al.	6,416,551 B1	7/2002	Keller
5,741,253 A	4/1998	Michelson	6,436,098 B1	8/2002	Michelson
5,776,198 A	7/1998	Rabbe et al.	6,440,139 B2	8/2002	Michelson
5,782,832 A	7/1998	Larsen et al.	6,447,544 B1	9/2002	Michelson
5,797,909 A	8/1998	Michelson	6,478,800 B1	11/2002	Fraser et al.
5,797,917 A *	8/1998	Boyd et al. 606/99	6,517,544 B1	2/2003	Michelson
5,824,094 A	10/1998	Serhan et al.	6,517,580 B1	2/2003	Ramadan et al.
5,836,948 A	11/1998	Zucherman et al.	6,520,967 B1	2/2003	Cauthen
5,865,846 A	2/1999	Bryan et al.	6,520,996 B1	2/2003	Manasas et al.
5,865,848 A	2/1999	Baker	6,527,804 B1	3/2003	Gauchet et al.
5,888,226 A	3/1999	Rogozinski	6,533,817 B1	3/2003	Norton et al.
5,895,428 A	4/1999	Berry	6,537,279 B1	3/2003	Michelson
5,899,901 A	5/1999	Middleton	6,554,863 B2	4/2003	Paul et al.
5,899,911 A	5/1999	Carter	6,562,047 B2	5/2003	Ralph et al.
5,928,284 A	7/1999	Mehdizadeh	6,562,074 B2	5/2003	Gerbec et al.
5,989,251 A	11/1999	Nichols	6,565,574 B2	5/2003	Michelson
5,989,291 A	11/1999	Ralph et al.	6,579,321 B1	6/2003	Gordon et al.
			6,582,466 B1	6/2003	Gauchet
			6,582,468 B1	6/2003	Gauchet
			6,592,624 B1	7/2003	Fraser et al.
			6,599,294 B2	7/2003	Fuss et al.
			6,607,558 B2	8/2003	Kuras
			6,607,559 B2	8/2003	Ralph et al.
			6,610,092 B2	8/2003	Ralph et al.
			6,623,525 B2	9/2003	Ralph et al.
			6,645,248 B2	11/2003	Casutt
			6,648,895 B2	11/2003	Burkus et al.
			6,652,533 B2	11/2003	O'Neil
			6,660,038 B2	12/2003	Boyer, II et al.
			6,666,866 B2	12/2003	Martz et al.
			6,669,731 B2	12/2003	Ralph et al.
			6,669,732 B2	12/2003	Serhan et al.
			6,673,113 B2	1/2004	Ralph et al.
			6,682,562 B2	1/2004	Viart et al.
			6,689,132 B2	2/2004	Biscup
			6,706,068 B2	3/2004	Ferree

US RE47,470 E

(56)	References Cited		
	U.S. PATENT DOCUMENTS		
	6,709,439 B2	3/2004 Rogers et al.	7,331,994 B2* 2/2008 Gordon A61F 2/442 623/17.13
	6,712,819 B2	3/2004 Zucherman et al.	7,331,995 B2 2/2008 Eisermann et al.
	6,712,825 B2	3/2004 Aebi et al.	7,429,270 B2 9/2008 Baumgartner et al.
	6,719,794 B2	4/2004 Gerber et al.	7,442,211 B2 10/2008 de Villiers et al.
	6,723,097 B2	4/2004 Fraser et al.	7,452,380 B2 11/2008 Zubok et al.
	6,726,720 B2	4/2004 Ross et al.	7,491,241 B2 2/2009 Errico et al.
	6,726,721 B2	4/2004 Stoy et al.	7,494,508 B2 2/2009 Zeegers
	6,733,532 B1	5/2004 Gauchet et al.	7,517,363 B2 4/2009 Rogers et al.
	6,740,118 B2	5/2004 Eisermann et al.	7,531,001 B2 5/2009 de Villiers et al.
	6,740,119 B2	5/2004 Ralph et al.	7,549,995 B2 6/2009 Schultz et al.
	6,752,832 B2	6/2004 Neumann	7,563,284 B2 7/2009 Coppes et al.
	6,755,841 B2	6/2004 Fraser et al.	7,563,286 B2 7/2009 Gerber et al.
	6,764,512 B2	7/2004 Keller	7,575,598 B2* 8/2009 Albert et al. 623/17.13
	6,764,515 B2	7/2004 Ralph et al.	7,578,848 B2* 8/2009 Albert et al. 623/17.13
	6,770,095 B2	8/2004 Grinberg et al.	7,585,324 B2* 9/2009 Albert et al. 623/17.13
	6,790,233 B2	9/2004 Brodke et al.	7,585,326 B2 9/2009 de Villiers et al.
	6,793,678 B2	9/2004 Hawkins	7,615,078 B2* 11/2009 White et al. 623/17.16
	6,814,737 B2	11/2004 Cauthen	7,635,368 B2 12/2009 Errico et al.
	6,821,298 B1	11/2004 Jackson	7,637,913 B2 12/2009 de Villiers et al.
	6,827,740 B1	12/2004 Michelson	7,655,045 B2 2/2010 Richelsoph
	6,830,570 B1	12/2004 Frey et al.	7,708,776 B1 5/2010 Blain et al.
	6,835,206 B2	12/2004 Jackson	7,708,777 B2 5/2010 O'Neil et al.
	6,846,328 B2	1/2005 Cauthen	7,731,753 B2 6/2010 Reo et al.
	6,852,126 B2	2/2005 Ahlgren	7,731,754 B2 6/2010 de Villiers et al.
	6,863,673 B2	3/2005 Gerbec et al.	7,749,272 B2 7/2010 Robie et al.
	6,875,213 B2	4/2005 Michelson	7,763,055 B2 7/2010 Foley
	6,896,680 B2	5/2005 Michelson	7,819,922 B2* 10/2010 Sweeney 623/17.16
	6,899,735 B2	5/2005 Coates et al.	8,057,545 B2 11/2011 Hughes et al.
	6,936,071 B1	8/2005 Marnay et al.	8,092,534 B2 1/2012 Eckhardt
	6,936,132 B2	8/2005 Topolnitsky	8,142,505 B2 3/2012 Tauber
	6,964,686 B2	11/2005 Gordon A61F 2/442 623/17.14	8,298,287 B2* 10/2012 Moumene A61F 2/442 623/17.16
	6,966,929 B2	11/2005 Mitchell	8,491,637 B2* 7/2013 Matthis A61B 17/702 606/254
	6,966,931 B2	11/2005 Huang	8,758,441 B2 6/2014 Hovda et al.
	6,986,788 B2	1/2006 Paul et al.	8,771,357 B2* 7/2014 Biedermann A61F 2/44 623/17.11
	6,989,011 B2	1/2006 Paul et al.	2001/0016773 A1 8/2001 Serhan et al.
	6,994,727 B2	2/2006 Khandkar et al.	2001/0029377 A1 10/2001 Aebi et al.
	7,011,684 B2	3/2006 Eckman	2001/0051829 A1 12/2001 Middleton
	7,022,138 B2	4/2006 Mashburn	2002/0022845 A1 2/2002 Zdeblick et al.
	7,025,787 B2	4/2006 Bryan et al.	2002/0035400 A1 3/2002 Bryan et al.
	7,044,972 B2	5/2006 Mathys et al.	2002/0045904 A1 4/2002 Fuss et al.
	7,044,983 B1	5/2006 Cheng	2002/0068936 A1 6/2002 Burkus et al.
	7,056,344 B2	6/2006 Huppert et al.	2002/0091392 A1 7/2002 Michelson
	7,060,073 B2	6/2006 Frey et al.	2002/0116009 A1 8/2002 Fraser et al.
	7,066,958 B2	6/2006 Ferree	2002/0123753 A1 9/2002 Michelson
	7,081,120 B2	7/2006 Li et al.	2002/0128715 A1 9/2002 Bryan et al.
	7,083,651 B2	8/2006 Diaz et al.	2002/0165550 A1 11/2002 Frey et al.
	7,087,055 B2	8/2006 Lim et al.	2002/0177897 A1 11/2002 Michelson
	7,097,648 B1	8/2006 Globerman et al.	2002/0198532 A1 12/2002 Michelson
	7,115,132 B2	10/2006 Errico et al.	2003/0009224 A1 1/2003 Kuras
	7,118,580 B1	10/2006 Beyersdorff et al.	2003/0014116 A1 1/2003 Ralph et al.
	7,147,665 B1	12/2006 Bryan et al.	2003/0023245 A1 1/2003 Ralph et al.
	7,153,325 B2	12/2006 Kim et al.	2003/0028249 A1 2/2003 Baccelli et al.
	7,169,182 B2	1/2007 Errico et al.	2003/0040746 A1 2/2003 Mitchell et al.
	7,179,294 B2	2/2007 Eisermann et al.	2003/0045884 A1 3/2003 Robie et al.
	7,182,784 B2	2/2007 Evans et al.	2003/0045939 A1 3/2003 Casutt
	7,198,644 B2	4/2007 Schultz et al.	2003/0074076 A1 4/2003 Ferree
	7,207,991 B2	4/2007 Michelson	2003/0083747 A1 5/2003 Winterbottom et al.
	7,214,244 B2	5/2007 Zubok et al.	2003/0100951 A1 5/2003 Serhan et al.
	7,217,291 B2	5/2007 Zucherman et al.	2003/0125739 A1 7/2003 Bagga
	7,235,082 B2	6/2007 Bartish et al.	2003/0130662 A1 7/2003 Michelson
	7,235,101 B2*	6/2007 Berry et al. 623/17.11	2003/0135277 A1 7/2003 Bryan et al.
	7,235,103 B2	6/2007 Rivin	2003/0139812 A1 7/2003 Garcia et al.
	7,250,060 B2	7/2007 Trieu	2003/0187448 A1 10/2003 Michelson
	7,255,714 B2	8/2007 Malek	2003/0191536 A1 10/2003 Ferree
	7,261,739 B2	8/2007 Ralph et al.	2003/0195517 A1 10/2003 Michelson
	7,267,688 B2	9/2007 Ferree	2003/0195631 A1 10/2003 Ferree
	7,270,679 B2	9/2007 Istephanous et al.	2003/0199982 A1 10/2003 Bryan
	7,270,682 B2	9/2007 Frigg et al.	2003/0199983 A1* 10/2003 Michelson 623/17.16
	7,303,582 B2	12/2007 Brady	2003/0204261 A1 10/2003 Eisermann et al.
	7,303,583 B1	12/2007 Schär et al.	2003/0208271 A1 11/2003 Kuras
	7,309,358 B2*	12/2007 Berry et al. 623/17.16	2003/0229358 A1 12/2003 Errico et al.
	7,318,839 B2	1/2008 Malberg et al.	2003/0233145 A1 12/2003 Landry et al.
	7,326,250 B2	2/2008 Beaurain et al.	2004/0002761 A1 1/2004 Rogers et al. A61F 2/4425 623/17.13
			2004/0024407 A1 2/2004 Ralph

(56)		References Cited			
		U.S. PATENT DOCUMENTS			
2004/0024410	A1	2/2004	Olson et al.	2006/0200239	A1 9/2006 Rothman et al.
2004/0030391	A1	2/2004	Ferree	2006/0200240	A1 9/2006 Rothman et al.
2004/0034426	A1	2/2004	Errico et al.	2006/0200242	A1 9/2006 Rothman et al.
2004/0054411	A1	3/2004	Kelly et al.	2006/0200243	A1* 9/2006 Rothman A61F 2/442
2004/0059318	A1	3/2004	Zhang et al.		623/17.13
2004/0073307	A1	4/2004	Keller	2006/0224241	A1* 10/2006 Butler et al. 623/17.15
2004/0073311	A1	4/2004	Ferree	2006/0235426	A1 10/2006 Lim et al.
2004/0073312	A1	4/2004	Eisermann et al.	2006/0235525	A1 10/2006 Gil et al.
2004/0093087	A1	5/2004	Ferree et al.	2006/0235527	A1 10/2006 Buettner-Janz et al.
2004/0097928	A1	5/2004	Zdeblick et al.	2006/0241641	A1 10/2006 Albans et al.
2004/0098131	A1	5/2004	Bryan et al.	2006/0241766	A1 10/2006 Felton et al.
2004/0117021	A1	6/2004	Biedermann et al.	2006/0259144	A1 11/2006 Trieu
2004/0143270	A1	7/2004	Zucherman et al.	2006/0259146	A1 11/2006 Navarro et al.
2004/0143332	A1	7/2004	Krueger et al.	2006/0265068	A1 11/2006 Schwab
2004/0143334	A1	7/2004	Ferree	2006/0265077	A1 11/2006 Zwirkoski
2004/0167626	A1	8/2004	Geremakis et al.	2006/0276902	A1 12/2006 Zipnick et al.
2004/0176843	A1	9/2004	Zubok et al.	2006/0287728	A1 12/2006 Mokhtar et al.
2004/0186569	A1	9/2004	Berry	2006/0293752	A1 12/2006 Moumene et al.
2004/0215342	A1	10/2004	Suddaby	2006/0293753	A1 12/2006 Thramann
2004/0225295	A1	11/2004	Zubok et al.	2006/0293754	A1 12/2006 de Villiers et al.
2004/0225365	A1	11/2004	Eisermann et al.	2007/0010826	A1 1/2007 Rhoda et al.
2004/0230307	A1	11/2004	Eisermann et al.	2007/0021837	A1 1/2007 Ashman et al.
2004/0236426	A1	11/2004	Ralph et al.	2007/0032875	A1 2/2007 Blacklock et al.
2004/0243238	A1	12/2004	Arin et al.	2007/0067035	A1 3/2007 Falahee
2004/0254644	A1	12/2004	Taylor	2007/0067036	A1 3/2007 Hudgins et al.
2005/0015094	A1	1/2005	Keller	2007/0073398	A1 3/2007 Fabian et al.
2005/0015095	A1	1/2005	Keller	2007/0093898	A1 4/2007 Schwab et al.
2005/0015152	A1	1/2005	Sweeney	2007/0100453	A1 5/2007 Parsons et al.
2005/0021145	A1	1/2005	de Villiers et al.	2007/0100454	A1 5/2007 Burgess et al.
2005/0021146	A1	1/2005	de Villiers et al.	2007/0100456	A1 5/2007 Dooris et al.
2005/0027360	A1	2/2005	Webb et al.	2007/0123903	A1 5/2007 Raymond et al.
2005/0038515	A1	2/2005	Kunzler	2007/0123904	A1 5/2007 Stad et al.
2005/0043800	A1	2/2005	Paul et al.	2007/0135923	A1 6/2007 Peterman et al.
2005/0085917	A1	4/2005	Marnay et al.	2007/0162133	A1 7/2007 Doubler et al.
2005/0107881	A1	5/2005	Alleynes et al.	2007/0168033	A1 7/2007 Kim et al.
2005/0113842	A1	5/2005	Bertagnoli et al.	2007/0168036	A1 7/2007 Ainsworth et al.
2005/0113928	A1	5/2005	Cragg	2007/0179615	A1 8/2007 Heinz et al.
2005/0143824	A1	6/2005	Richelsof et al.	2007/0213821	A1 9/2007 Kwak et al.
2005/0149189	A1	7/2005	Mokhtar et al.	2007/0233077	A1 10/2007 Khalili
2005/0154463	A1	7/2005	Trieu	2007/0233247	A1 10/2007 Schwab
2005/0165408	A1	7/2005	Puno et al.	2007/0233248	A1 10/2007 Schwab et al.
2005/0171604	A1	8/2005	Michalow	2007/0233251	A1 10/2007 Abdou
2005/0187634	A1*	8/2005	Berry 623/17.15	2007/0270956	A1 11/2007 Heinz
2005/0192586	A1	9/2005	Zucherman et al.	2007/0270970	A1 11/2007 Trieu
2005/0192670	A1	9/2005	Zubok et al.	2007/0282449	A1 12/2007 de Villiers et al.
2005/0197706	A1	9/2005	Hovorka et al.	2007/0299521	A1 12/2007 Glenn et al.
2005/0216081	A1	9/2005	Taylor	2008/0015698	A1 1/2008 Marino et al.
2005/0216084	A1	9/2005	Fleischmann et al.	2008/0015701	A1 1/2008 Garcia et al.
2005/0234553	A1	10/2005	Gordon	2008/0021557	A1 1/2008 Trieu
2005/0251260	A1	11/2005	Gerber et al.	2008/0051900	A1 2/2008 de Villiers et al.
2005/0251261	A1	11/2005	Peterman	2008/0051901	A1 2/2008 de Villiers et al.
2005/0261772	A1	11/2005	Filippi et al.	2008/0125864	A1 5/2008 de Villiers et al.
2005/0267580	A1	12/2005	Suddaby	2008/0125865	A1 5/2008 Abdelgany
2005/0267581	A1	12/2005	Marnay et al.	2008/0133011	A1 6/2008 de Villiers et al.
2006/0004377	A1	1/2006	Keller	2008/0154301	A1 6/2008 de Villiers et al.
2006/0004453	A1	1/2006	Bartish et al.	2008/0154305	A1 6/2008 Foley et al.
2006/0015183	A1	1/2006	Gilbert et al.	2008/0154382	A1 6/2008 de Villiers et al.
2006/0020342	A1	1/2006	Ferree et al.	2008/0161926	A1* 7/2008 Melkent et al. 623/17.16
2006/0025862	A1	2/2006	Villiers et al.	2008/0215155	A1 9/2008 de Villiers et al.
2006/0030862	A1	2/2006	de Villiers et al.	2008/0221696	A1 9/2008 de Villiers et al.
2006/0036325	A1	2/2006	Paul et al.	2008/0228274	A1 9/2008 de Villiers et al.
2006/0041313	A1	2/2006	Allard et al.	2008/0228277	A1 9/2008 de Villiers et al.
2006/0041314	A1	2/2006	Millard	2008/0294259	A1 11/2008 de Villiers et al.
2006/0052870	A1	3/2006	Feree	2009/0043391	A1 2/2009 de Villiers et al.
2006/0064169	A1	3/2006	Feree et al.	2009/0048674	A1 2/2009 Zubok et al.
2006/0069439	A1	3/2006	Zucherman et al.	2009/0048677	A1 2/2009 McLeod et al.
2006/0116768	A1	6/2006	Krueger et al.	2009/0076614	A1 3/2009 Arramon A61F 2/4425
2006/0136061	A1	6/2006	Navarro et al.		623/17.16
2006/0142858	A1	6/2006	Colleran	2009/0105833	A1 4/2009 Hovda et al.
2006/0142862	A1	6/2006	Diaz et al.	2009/0105834	A1 4/2009 Hovda et al.
2006/0155378	A1	7/2006	Eckman	2009/0105835	A1 4/2009 Hovda et al.
2006/0167549	A1	7/2006	Mathys et al.	2009/0118836	A1* 5/2009 Cordaro A61F 2/4455
2006/0178744	A1	8/2006	de Villiers et al.		623/17.16
2006/0178746	A1	8/2006	Bartish, Jr. et al.	2009/0192617	A1 7/2009 Arramon et al.
2006/0195097	A1	8/2006	Evans et al.	2009/0205188	A1 8/2009 de Villiers et al.
				2009/0210060	A1 8/2009 de Villiers et al.
				2009/0222101	A1 9/2009 de Villiers et al.
				2009/0276051	A1 11/2009 Arramon et al.
				2009/0326656	A1 12/2009 de Villiers et al.

(56)

References Cited

U.S. PATENT DOCUMENTS

2010/0004746 A1 1/2010 Arramon
 2010/0004748 A1* 1/2010 Cordaro A61F 2/442
 623/17.16
 2010/0016972 A1 1/2010 Jansen et al.
 2010/0016973 A1 1/2010 de Villiers et al.
 2010/0030335 A1 2/2010 Arramon
 2010/0049040 A1 2/2010 de Villiers et al.
 2010/0069976 A1 3/2010 de Villiers et al.
 2010/0076558 A1 3/2010 de Villiers et al.
 2010/0087868 A1 4/2010 Barr et al.
 2010/0100141 A1 4/2010 de Villiers et al.
 2010/0179419 A1 7/2010 de Villiers et al.
 2010/0268344 A1 10/2010 de Villiers et al.
 2017/0071757 A1 3/2017 Hovda et al.

FOREIGN PATENT DOCUMENTS

DE 10035182 A1 2/2002
 EP 0333990 A2 9/1989
 EP 0333990 A3 5/1990
 EP 0560140 A1 9/1993
 EP 0560141 A1 9/1993
 EP 0591712 A1 4/1994
 EP 0820740 A1 1/1998
 EP 1142544 A1 10/2001
 EP 1153582 A2 11/2001
 EP 1153582 A3 11/2001
 EP 1250898 A1 10/2002
 EP 1306064 A1 5/2003
 EP 1344493 A1 9/2003
 EP 1344506 A1 9/2003
 EP 1344507 A1 9/2003
 EP 1344508 A1 9/2003
 EP 1417940 A1 5/2004
 EP 1570813 A1 9/2005
 FR 2803741 A1 7/2001
 JP 61122859 A 6/1986
 JP S61122859 A 6/1986
 JP 63164948 A 7/1988
 JP S63164948 A 7/1988
 WO WO-9920209 A1 4/1999
 WO WO-9930651 A1 6/1999
 WO WO-0004851 A1 2/2000
 WO WO-0035384 A1 6/2000
 WO WO-0042954 A2 7/2000
 WO WO-0042954 A3 11/2000
 WO WO-0101893 A1 1/2001
 WO WO-0115637 A1 3/2001
 WO WO-0168003 A1 9/2001
 WO WO-0211650 A2 2/2002

WO WO-0211650 A3 9/2003
 WO WO-2004000170 A1 12/2003
 WO WO-2004000171 A1 12/2003
 WO WO-2004026187 A1 4/2004
 WO WO-2004054477 A1 7/2004
 WO WO-2005004756 A2 1/2005
 WO WO-2005004756 A3 5/2005
 WO WO-2005053580 A1 6/2005
 WO WO-2005072662 A1 8/2005
 WO WO-2005112834 A2 12/2005
 WO WO-2005112834 A3 5/2006
 WO WO-2006119092 A2 11/2006
 WO WO-2006119092 A3 12/2006
 WO WO-2007121320 A2 10/2007
 WO WO-2007121320 A3 6/2008
 ZA 2003/9312 11/2003
 ZA 200603171 9/2007

OTHER PUBLICATIONS

Office action dated Feb. 8, 2012 for U.S. Appl. No. 12/255,731.
 Office action dated Apr. 18, 2012 for U.S. Appl. No. 12/255,733.
 Office action dated Jun. 7, 2011 for U.S. Appl. No. 12/255,731.
 Office action dated Aug. 26, 2011 for U.S. Appl. No. 12/255,733.
 Office action dated Nov. 23, 2012 for U.S. Appl. No. 12/255,731.
 Office action dated Nov. 28, 2012 for U.S. Appl. No. 12/255,733.
 "Office Action dated Dec. 19, 2017 for U.S. Appl. No. 15/359,298".
 International search report and written opinion dated Dec. 16, 2008
 for PCT/US2008/080800.
 Office action dated May 13, 2011 for U.S. Appl. No. 12/255,737.
 Office action dated Jun. 19, 2012 for U.S. Appl. No. 12/255,737.
 Office action dated Dec. 15, 2011 for U.S. Appl. No. 12/255,737.
 Office action dated Dec. 18, 2012 for U.S. Appl. No. 12/255,737.
 International Search Report and Written Opinion of PCT Applica-
 tion No. PCT/US08/80800, dated Dec. 16, 2008, 11 pages total.
 Buttner-Janz, The Development of the Artificial Disc. Introduction,
 pp. 1-18, Library of Congress Catalogue No. 92-75582, ISBN
 0-9635430-0-8 (1989).
 Hellier, et al. Wear Studies for Development of an Intervertebral
 Disc Prosthesis. Spine, vol. 17 No. 6 Supplement pp. 86-96 (1992).
 International search report and written opinion dated Dec. 19, 2008
 for PCT/US2008/080798.
 International search report and written opinion dated Dec. 29, 2008
 for PCT/US2008/080804.
 Lee, et al. Impact Response of the Intervertebral Disc in a Finite-
 Element Model. Spine. 2000; 25(19):2431-2439.
 Lehuac, et al. Shock Absorption in Lumbar Disc Prosthesis. Journal
 of Spinal Disorders & Techniques. 2003; 16(4):346-351.
 Office action dated Aug. 14, 2013 for U.S. Appl. No. 12/255,731.

* cited by examiner

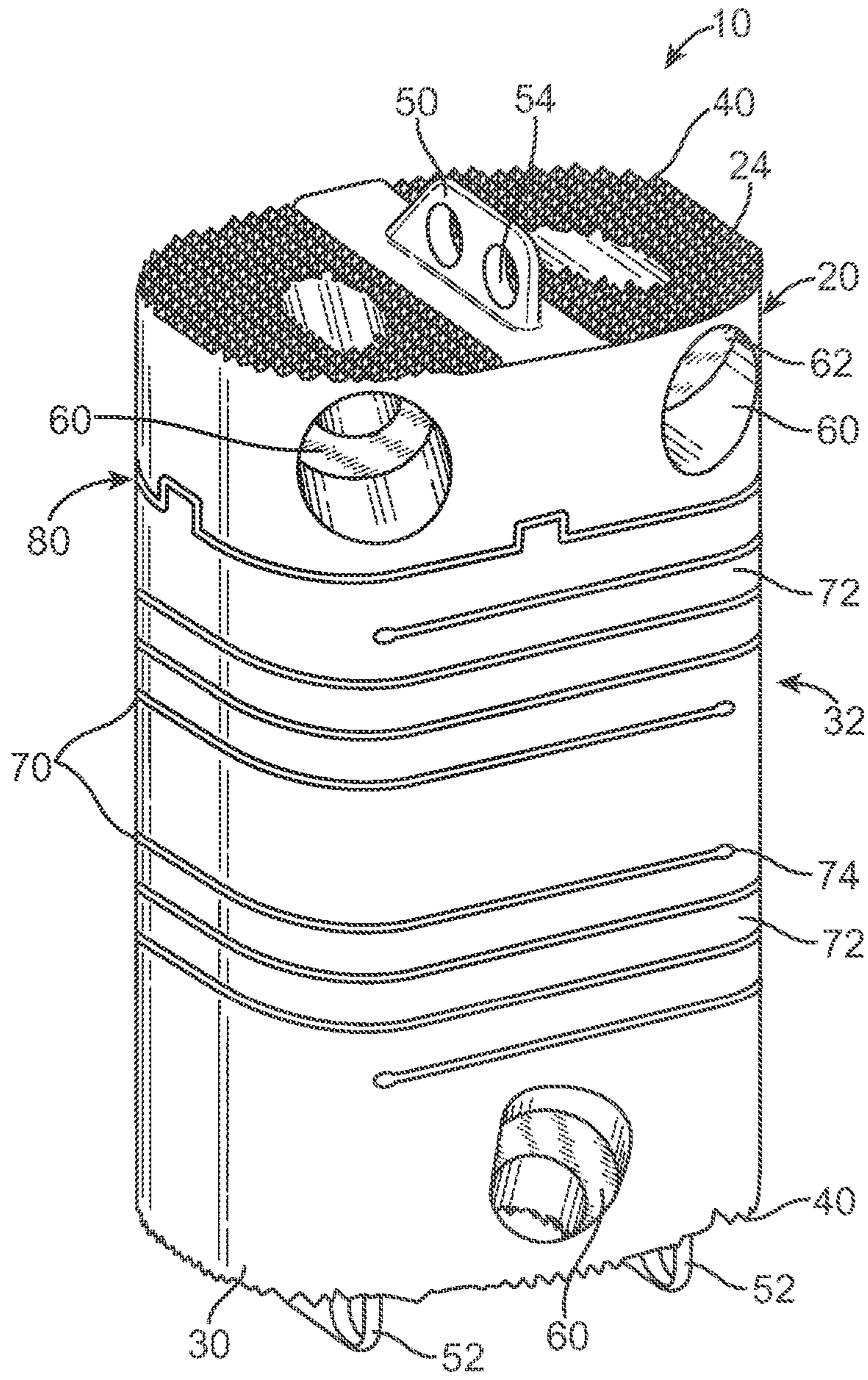

FIG. 1

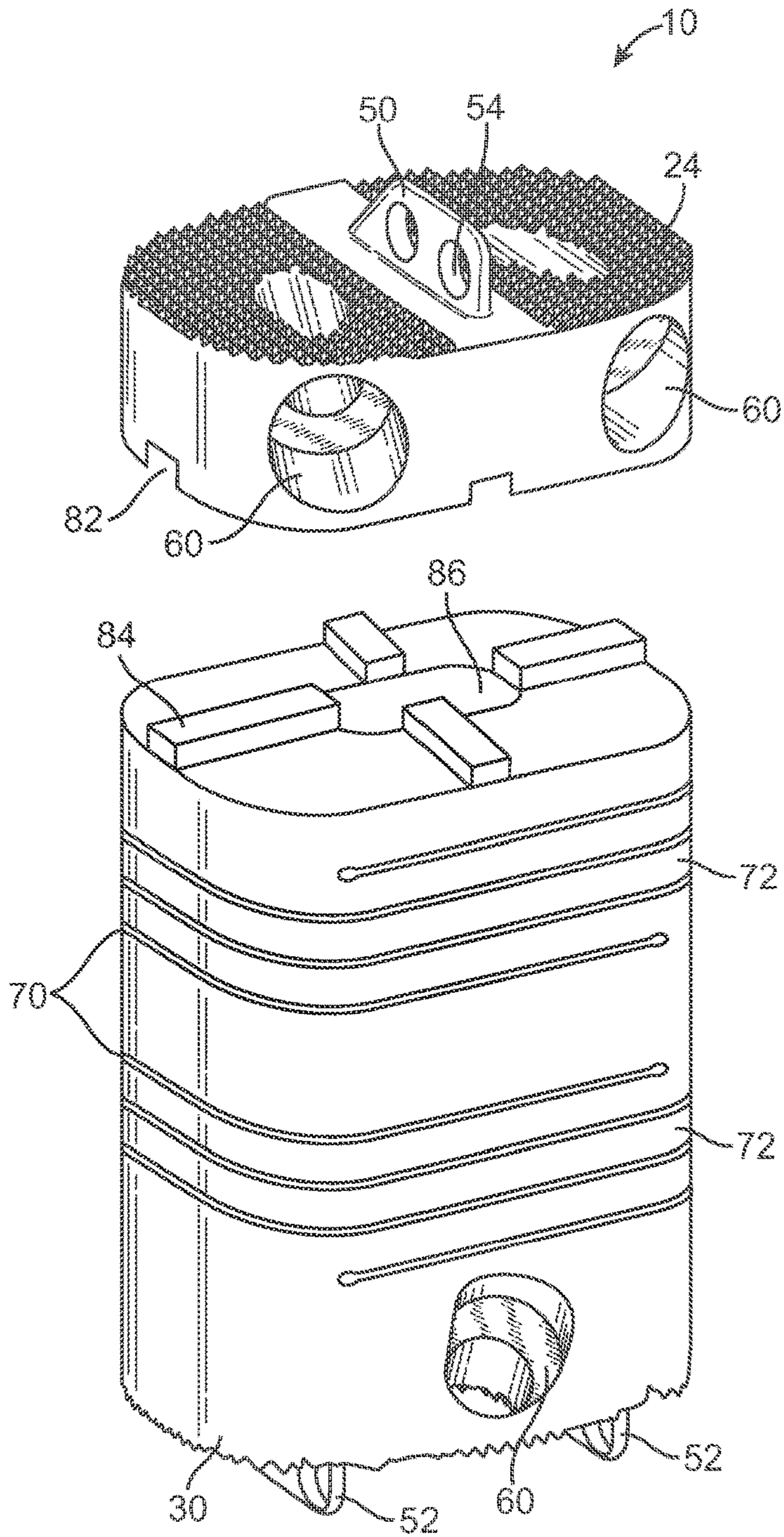

FIG. 1A

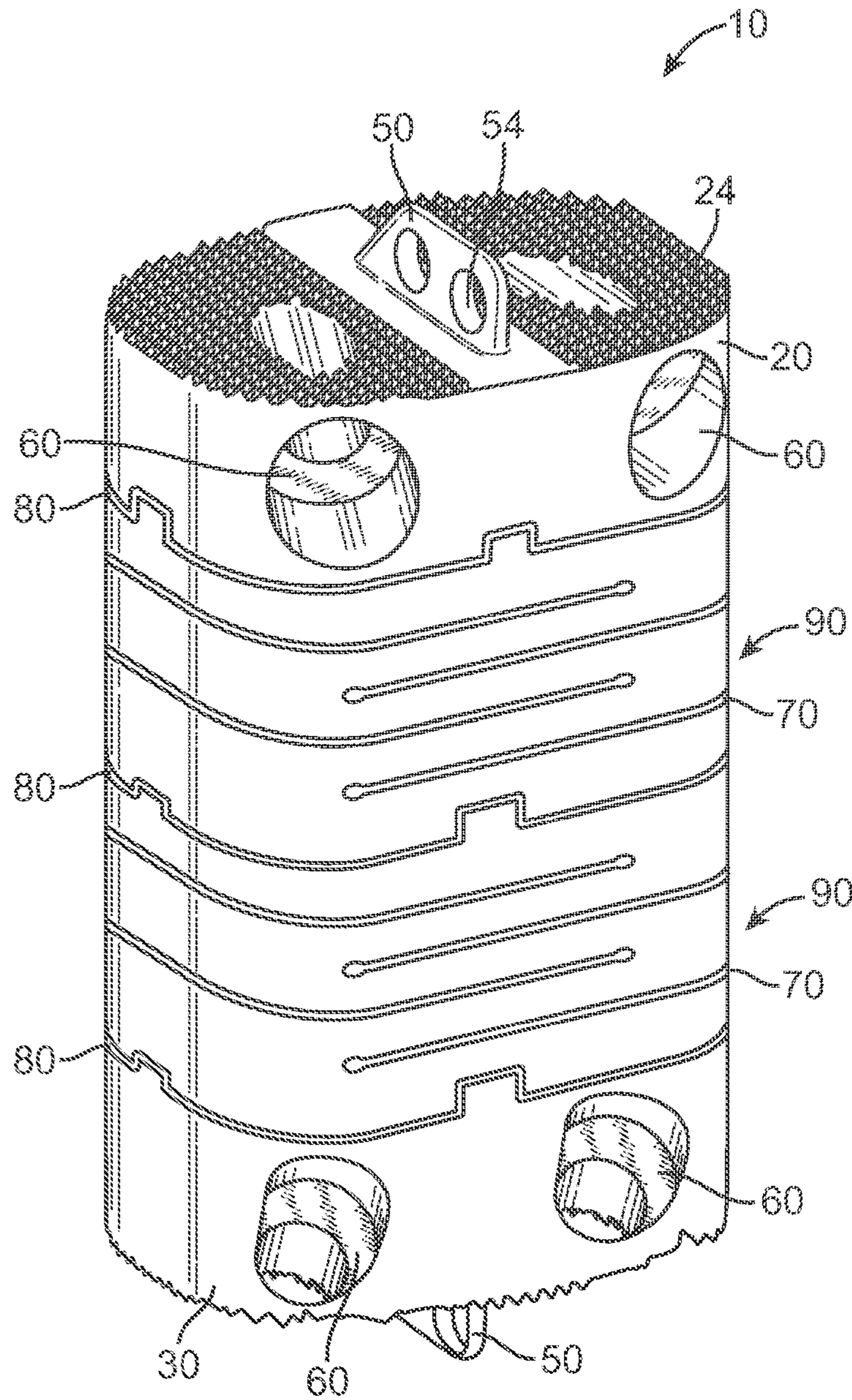

FIG. 2

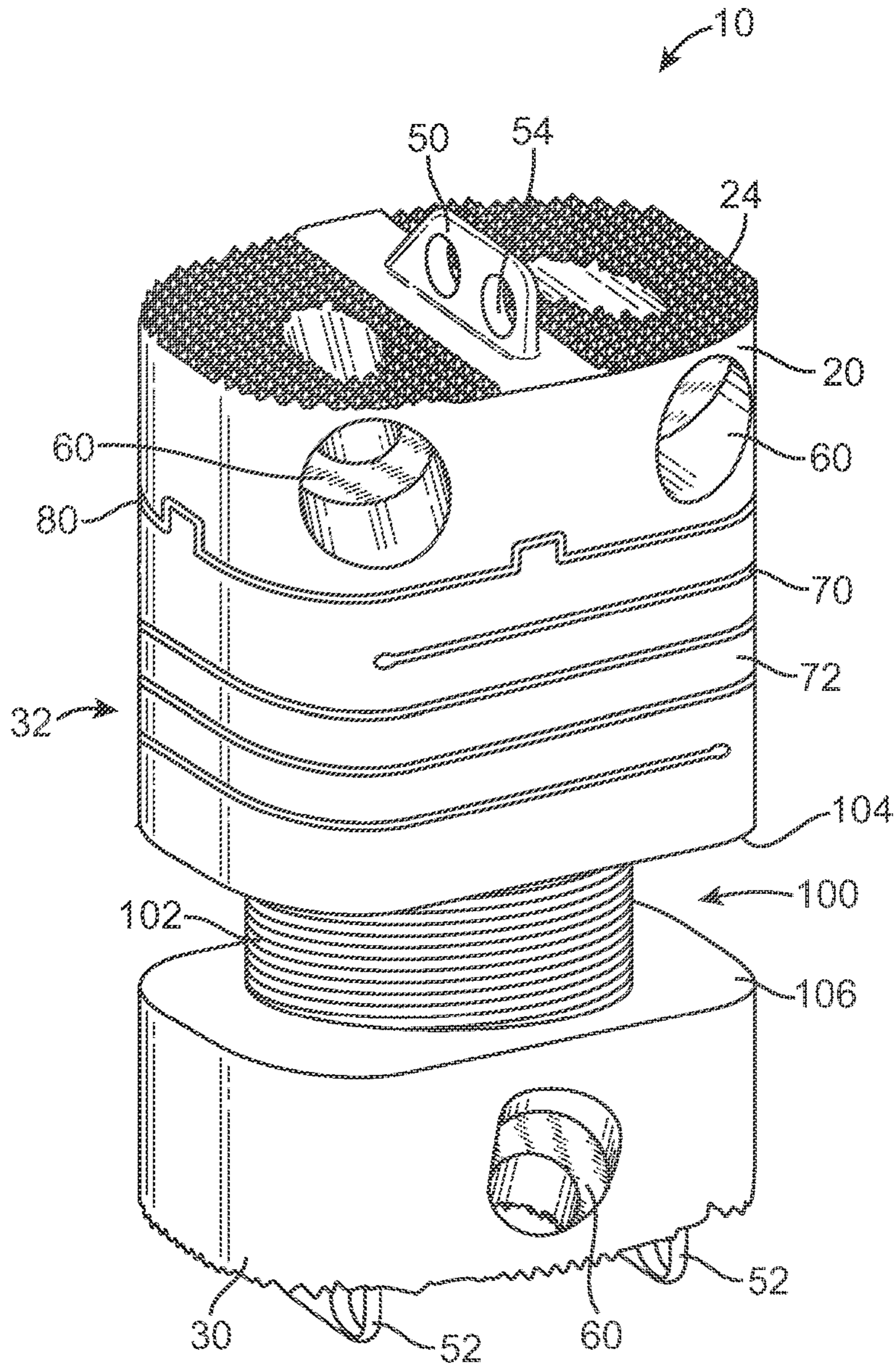

FIG. 3

1

**VERTEBRAL BODY PLACEMENT AND
METHOD FOR SPANNING A SPACE
FORMED UPON REMOVAL OF A
VERTEBRAL BODY**

Matter enclosed in heavy brackets [] appears in the original patent but forms no part of this reissue specification; matter printed in italics indicates the additions made by reissue; a claim printed with strikethrough indicates that the claim was canceled, disclaimed, or held invalid by a prior post-patent action or proceeding.

CROSS-REFERENCES TO RELATED
APPLICATIONS

This application claims priority under 35 U.S.C. §119 to U.S. Provisional Application No. 60/981,665 filed Oct. 22, 2007, entitled "Method and Spacer Device Spanning Space Formed Upon Removal of an Intervertebral Disc," the full disclosure of which is incorporated herein by reference.

BACKGROUND OF THE INVENTION

The present invention relates to medical devices and methods. More specifically, the invention relates to vertebral body replacements and methods of spanning a space formed upon removal of an intervertebral disc.

Back pain takes an enormous toll on the health and productivity of people around the world. According to the American Academy of Orthopedic Surgeons, approximately 80 percent of Americans will experience back pain at some time in their life. In the year 2000, approximately 26 million visits were made to physicians' offices due to back problems in the United States. On any one day, it is estimated that 5% of the working population in America is disabled by back pain.

One common cause of back pain is injury, degeneration and/or dysfunction of one or more intervertebral discs. Intervertebral discs are the soft tissue structures located between each of the thirty-three vertebral bones that make up the vertebral (spinal) column. Essentially, the discs allow the vertebrae to move relative to one another. The vertebral column and discs are vital anatomical structures, in that they form a central axis that supports the head and torso, allow for movement of the back, and protect the spinal cord, which passes through the vertebrae in proximity to the discs.

Another form of spinal injury involves injury or deformity of the vertebra themselves. When one or more vertebrae is fracture or deformed by tumor or other causes and results in pain and discomfort, surgery is often required. Traditionally, surgical procedures for vertebral replacement have involved removal of the vertebra and fusion of the two vertebrae above and below the missing vertebra. It is necessary to replace the removed vertebra to maintain spacing of adjacent vertebrae. Oftentimes, pins, rods, screws, cages and/or the like are inserted between the vertebrae to act as support structures to hold the vertebrae and graft material in place while they permanently fuse together. These vertebral body replacement procedures generally focus on rigidly fusing the adjacent vertebrae and preventing motion.

However, it would be desirable to achieve immobilization of the vertebrae adjacent a removed vertebral body and maintain spacing between the adjacent vertebrae without the complete rigidity of traditional interbody fusion.

Another problem associated with the typical vertebral body replacement procedure is the subsidence of the cage

2

into the vertebral body. The typical vertebral body replacement cage is formed with a large percentage of open space to allow the bone to grow through and form the bridging bone which immobilizes the vertebrae. However, the large amount of open space means that the load on each segment of the cage is significantly higher than if the cage surface area was larger. This results in the cage subsiding or sinking into the bone over time and allows the space between the vertebrae to collapse.

Therefore, a need exists for improved vertebral body replacement and method for spanning a space and maintaining spacing between two vertebrae after removal of an intervertebral body. Such improved method and intervertebral body replacement would avoid the need for growth of bridging bone between the remaining vertebrae.

BRIEF SUMMARY OF THE INVENTION

Embodiments of the present invention provide a vertebral body replacement with compliance or shock absorption and methods of spanning a space formed upon removal of vertebral body.

In accordance with one of numerous aspects of the present invention, a vertebral body replacement for replacing at least one vertebral body between remaining upper and lower vertebral bodies, the vertebral body replacement comprises a first end plate having an upper surface configured to engage against a surface of the upper remaining vertebral body, and a lower surface opposite the upper surface spanning the first end plate, a second end plate having a lower surface configured to engage against a surface of the lower remaining vertebral body, and a compliant connector section between the first end plate lower surface and the second end plate lower surface, the compliant connector section comprising at least one helical cut configured and arranged to permit limited motion between the first end plate and the second end plate.

In accordance with another aspect of the invention, a method of replacing at least one vertebral body comprises removing said at least one vertebral body between two remaining vertebral bodies, placing a vertebral body replacement between said two remaining vertebral bodies, the vertebral body replacement comprising first and second end plates and a compliant connector section between the first and second end plates, the compliant connector section having at least one helical cut and configured and arranged to limit motion to less than 10 degrees between said remaining vertebral bodies, and maintaining the space between the two remaining vertebral bodies with the vertebral body replacement.

BRIEF DESCRIPTION OF THE DRAWINGS

FIG. 1 is a perspective view of a vertebral body replacement according to one embodiment of the present invention;

FIG. 1A is an exploded, perspective view of the vertebral body replacement of FIG. 1;

FIG. 2 is a perspective view of a vertebral body replacement according to a second exemplary embodiment of the present invention; and

FIG. 3 is a perspective view of a vertebral body replacement according to a third exemplary embodiment of the present invention.

DETAILED DESCRIPTION OF THE
INVENTION

Various embodiments of the present invention generally provide for a vertebral body replacement having upper and

lower plates or surfaces connected by a central connector portion which provides some limited amount of axial compliance and/or rotational motion between the upper and lower plates or surfaces. The compliant vertebral body replacement according to the present invention can maintain disc height and prevent subsidence with a large surface area while improving outcomes by allowing some limited motion and providing improved fixation. The compliance of the vertebral body replacement also functions to reduce loading on the interface between the bone and vertebral body replacement.

One example of a vertebral body replacement **10** for replacement of a vertebral body and maintaining disc height between two adjacent vertebral discs is shown in FIG. **1**. The body **10** includes at least one end plate **20** having a vertebral body contacting surface **24**, a second end plate or body end **30** opposite the end plate **20**, and a compliant connector or connector section **32** interposed between, or interconnecting, the two ends **20**, **30**. As will be described below, some limited rotational and axial motion may be provided between the two plates or sections **20**, **30** to reduce loading on the interface between the adjacent vertebral bodies and the body **10**. According to an exemplary device embodying principles of the present invention, the compliance of the connector **32**, as well as some small amount of translation and rotation, is provided by lateral cuts or slots **70** extending into the connector **32**. The body **10** when implanted between two vertebrae maintains a desirable space between the two adjacent vertebrae similar to that provided by a natural vertebra.

Although the body **10** has been shown as generally oblong in cross section, other shapes may be used, including circular, oval, elliptical, or rectangular. Although the connector section **32** has been illustrated in FIG. **1** as integral with the end section **30**, according to other embodiments, the connector can include one or more separate compliant connectors or spacers in other configurations and at other locations. By way of example, a compliant connector may be the same or substantially the same diameter, size, and shape as the plates, multiple connectors can be arranged in a rectangular pattern, or a hollow cylindrical connector can be used. Further optionally, while the surfaces **24** are illustrated being perpendicular to the vertical axis of the body **10**, one or both of the surfaces **24** can be somewhat wedge-shaped, formed with one or two lordosis angles, as well known to those of ordinary skill in the art. The modular design of the upper plate **20** and the lower plate section **30** allows the creation of a complete bodies **10** of different sizes to correspond to the particular space for each patient.

The upper plate **20** and the lower plate or plate section **30**, and connector **32**, may be constructed from any suitable metal, alloy or combination of metals or alloys, such as but not limited to cobalt chrome alloys, titanium (such as grade **5** titanium), titanium based alloys, tantalum, nickel titanium alloys, stainless steel, and/or the like. They may also be formed of ceramics, biologically compatible polymers including PEEK, UHMWPE (ultra high molecular weight polyethylene) or fiber reinforced polymers. However, when polymer is used for the body **10**, the contacting surfaces **24** may be coated or otherwise covered with metal for fixation. The upper plate **20** and the lower plate or plate section **30**, and connector **32**, may be formed of a one piece construction or may be formed of more than one piece, such as different materials coupled together. When the body **10** is formed of multiple materials, these materials are fixed together to form a unitary one piece spacer without separately moving parts.

Different materials may be used for different parts of the body **10** to optimize imaging characteristics. For example, the upper plate **20** and the lower plate or plate section **30** may be formed of titanium, while the connector **32** is formed of cobalt chromium alloy for improved imaging of the plates. Cobalt chrome molybdenum alloys, when used for the plates **20**, **30** may be treated with aluminum oxide blasting followed by a titanium plasma spray to improve bone integration. Other materials and coatings can also be used such as titanium coated with titanium nitride, aluminum oxide blasting, HA (hydroxylapatite) coating, micro HA coating, and/or bone integration promoting coatings. Any other suitable metals or combinations of metals may be used as well as ceramic or polymer materials, and combinations thereof. Any suitable technique may be used to couple materials together, such as snap fitting, slip fitting, lamination, interference fitting, use of adhesives, welding and/or the like.

In some embodiments, the outer surface **24** is planar. Oftentimes, the outer surface **24** will include one or more surface features and/or materials to enhance attachment of the body **10** to vertebral bone. For example, as shown in FIG. **1**, the outer surface **24** may be machined to have serrations **40** or other surface features for promoting adhesion of the plates **20**, **30** to a vertebra. In the embodiment shown, the serrations **40** are pyramid shaped serrations extending in mutually orthogonal directions, but other geometries such as teeth, grooves, ridges, pins, barbs or the like would also be useful. When the bone integration structures are ridges, teeth, barbs or similar structures, they may be angled to ease insertion and prevent migration. These bone integration structures can be used to precisely cut the bone during implantation to cause bleeding bone and encourage bone integration. Additionally, the outer surface **24** may be provided with a rough microfinish formed by blasting with aluminum oxide microparticles or the like to improve bone integration. In some embodiments, the outer surface may also be titanium plasma sprayed or HA coated to further enhance attachment of the outer surface **24** to vertebral bone.

The outer surfaces **24** may also carry one or more upstanding fins **50**, **52** which also extend laterally in an anterior-posterior direction. The fins **50**, **52** are configured to be placed in slots in the vertebral bodies. Preferably, the fins **50**, **52** each have a height greater than a width and have a lateral length greater than the height. In one embodiment, the fins **50**, **52** are pierced by transverse holes **54** for bone ingrowth. The transverse holes **54** may be formed in any shape and may extend partially or all the way through the fins **50**, **52**. In alternative embodiments, the fins **50**, **52** may be rotated away from the anterior-posterior axis, such as in a lateral-lateral orientation, a posterolateral- anterolateral orientation, or the like.

The fins **50**, **52** provide improved attachment to the bone and prevent rotation of the plates **20**, **30** in the bone. In some embodiments, the fins **50**, **52** may extend from the surface **24** at an angle other than 90°. For example, on one or more of the plates **20**, **22** where multiple fins **52** are attached to the surface **24**, the fins may be canted away from one another with the bases slightly closer together than their edges at an angle such as about 80-88 degrees. The fins **50**, **52** may have any other suitable configuration including various numbers angles and curvatures, in various embodiments. In some embodiments, the fins **50**, **52** may be omitted altogether. The embodiment of FIG. **1** illustrates a combination of one plate with a single fin **50** and another plate with a double fin **52**. This arrangement is useful for double level disc replace-

5

ments and utilizes offset slots in the vertebral body to prevent the rare occurrence of vertebral body splitting by avoiding cuts to the vertebral body in the same plane for multi-level implants. The combination of the single fin 50 and double fin 52 can also assist the surgeon in placement of the spacer in the correct orientation.

The body 10 has been shown with the fins 50, 52 as the primary fixation feature; however, the fins may also be augmented or replaced with one or more screws extending through the plates and into the bone. For example in the body 10 of FIG. 1, the upper fin 50 may be augmented or replaced with one or more screws (not illustrated) while the two lower fins 52 remain. The plates 20, 30 can be provided with one or a series of holes 60 to allow screws to be inserted at different locations at the option of the surgeon. However, the holes 60 should not be of such size or number that the coverage of the plate 20, 30 is decreased to such an extent that subsidence occurs. Alternately, the screws can pass laterally through one or more of the holes in the fins. When one or more screws are provided, they may incorporate a locking feature to prevent the screws from backing out. The screws may also be provided with a bone integration coating.

Some limited holes may also be provided in the plate to allow bone ingrowth. However, if the outer surfaces 24 have holes therein, the holes advantageously cover less than 40 percent of the outer surface 24 which contacts the bone to prevent subsidence of the plates into the vertebral bodies. Preferably the holes will cover less than 25 percent, and more preferably less than 10 percent of the outer bone contacting surfaces. At the option of the surgeon, when the small holes are present in the plates 20, 30, bone graft can be placed in the holes to allow bone to grow through the plates. The embodiments illustrated in FIGS. 1-3 also illustrate the optional inclusion of countersunk screw holes 60 extending between a lateral surface of the plates 20, 30 and the end surfaces 24, in which bone screws may optionally be inserted to further stabilize the body 10. The holes 60 can alternatively extend vertically through the end plates, or the end plates can include combinations of vertical and angled holes.

The vertebral body replacement 10 shown herein is configured for placement in the vertebral column from an anterior approach. It should be understood that other approaches can be used, and the particular shape of the vertebral body replacement would be modified depending on the approach. For example, for a lateral approach, the vertebral body replacement may be formed in a more elongated, kidney bean, or banana shape with a transversely oriented fin.

As shown in FIG. 1, the vertebral body replacement 10 is provided with shock absorption or some other limited motion between the two plates 20, 30 by providing a compliant connector 32. The limited motion provided by the compliant connector 32 is designed to reduce forces on the interface between the outer surfaces 24 and the bone to improve long term fixation of the spacer. The compliance of the connector 32 allows motion between the vertebral bodies to be accommodated by the compliance in the body 10 rather than causing one or both of the vertebral bodies to pull away from the plates 20, 30. The compliant connector 32 provides limited relative motion between the plates, which may include compliance in a vertical direction of up to about 6 mm, rotation in an anterior/posterior direction, lateral direction, or axial rotation of less than about 10 degrees, and/or translation of up to about 1 mm.

6

In the vertebral body replacement 10 of FIG. 1, the compliance, as well as some small amount of translation and rotation, is provided by the cuts or slots 70 extending into the connector 32. In the embodiment of FIG. 1, the slots 70 are spiral slots, however, other shaped slots may also be used. The compliant connector 32 is advantageously formed as a unitary member with at least one lateral cut or slot 70 positioned between the upper and lower plates 20, 30, permitting the plates to move resiliently toward and away from each other. The replacement 10 can also be formed as multiple parts where different properties are desired from the different parts, such as different radiopacities, different strengths, or different flexibility properties and for flexibility in creating the size and configuration of spacer suited to the patient. The lateral cuts 70 in the connector 32 allow the connector to function as a compliant member without affecting the function of the upper and lower plates of the body 10.

FIG. 2 illustrates an alternative embodiment of a body 10 having multiple parts including end plates 20, 30 and spacers 90. The spacers 90 include lateral cuts 70 in place of the spiral cuts of FIG. 1. The material remaining after the cuts 70 are made is called a column. A shallow cut, that is, one that extends laterally into the connector a relatively small distance, and a large column provides a stiffer spacer, while a deeper cut and smaller column provides a more compliant spacer. In the embodiment shown in FIG. 2, the cuts 70 are at least 60% of the way through the spacer width or diameter, and preferably at least 75% of the way through the connector width.

Optionally, a variable stiffness shock absorbing connector 32 (FIG. 1) or spacer 90 (FIG. 2) can be constructed with lateral cuts 70 with tapering widths. For cuts with such tapering widths, the cut 70 is smallest where the cut terminates adjacent the column and is largest at the edge of the connector 32 furthest from the column. In this version, each of the lateral cuts 70 causes the connector 32 to act as a non linear spring providing progressively stiffer behavior upon larger compression. This is due to the fact that progressively more material on the sides of the cuts 70 is in contact as the connector 32 or spacer 90 is compressed. The non-linear spring can be incorporated in any of the other embodiments described herein to provide a softer stop to the compliant action of the core. The tapered width cuts 70 can provide the additional benefit of providing a flushing action during operation that moves any accumulated material out of the cuts.

The cuts 70 also advantageously include a stress relief 74 at the end of the cuts which increases the fatigue life of the device by reducing the stress concentration at the ends of the slots.

In the exemplary embodiments illustrated herein, a shock absorbing connector 32 includes either one or more planar cuts 70 (FIG. 2), or alternatively one or more spiral or helical cuts 70 (FIG. 1) to form one or more continuous spring coil elements 72 which provide compliance to the connector. Although the spiral cut connector 32 is illustrated in FIG. 1 with two spiral cuts, only one, or three or more spiral cuts may also be employed. For example, two or more spiral cuts 70 arranged in opposite directions can be formed in the connector 32, as illustrated in FIG. 1. Furthermore, when more than one spiral cut 70 is provided, the cuts can optionally be nested one inside the other (not illustrated), as in the manner of a multi-start thread, and/or can include combinations of both nested and adjacent cuts (such as those illustrated in FIGS. 1-2). The compression of a spiral cut connector 70 can result in some small amount of relative rotation between the upper and lower surfaces 20, 30. In

cases where it is desirable to eliminate this rotation, a connector **32** having multiple spiral cuts in opposite directions can be used. For example, a connector **32** can be formed with a first spiral cut **70** at a top of the connector in a first direction and a second spiral cut **70** at a bottom of the core in an opposite second direction. The first and second spiral cuts can offset rotation of each other resulting in a non rotating compliant connector. The double spiral embodiment of the connector is also more stable in shear than the single coil. Furthermore, coils **74** provide significantly more surface area between the adjoining surfaces of the cuts **70** than do planar cuts, which can be advantageous to allow limited rotational motion. The spiral cuts **70** can be made parallel to the end surfaces of the body **10** or can be angled, as in a cone shape. When the spiral cuts **70** are angled to form a cone shaped spring the cone shaped surfaces can limit the translational movement of the spring.

In each of the shock absorbing connectors described herein, the interconnected sections within the connector and the plate(s) are designed for minimal or no motion between contacting parts to prevent particulate generation. However, since the plates and connectors are made entirely of hard materials such as metals, some minimal rubbing contact may be accommodated. In the exemplary embodiments illustrated in figures herein, a rotational interlock **80** is provided between the lower surface of the end plate **20** and the adjoining upper surface of the connector section **32** of the end plate **30**. With reference to FIG. 2, the exemplary interlock **80** includes complementary portions **82**, **84**, formed on the adjoining faces of the end plate **20** and the connector section **32**, in the exemplary body **10**, taking the shape of simple raised portions or ribs **84** which mate with correspondingly sized and shaped recesses **82**. The rotational interlock **80** is not limited to the particular shapes or orientations illustrated in the drawing figures, and can take any shape or orientation which resists, and advantageously prevents, the plate **20** and the connector section **32** from rotating relative to each other. The rotational interlock **80** on the top and bottom surface of a spacer **90** can be different to allow the complete body **10** to be assembled only in a particular desired configuration.

Further optionally, as illustrated in FIG. 1A, the body **10** can include one or more blind cavities **86** extending vertically through the connector section **32**, which provides the interior side of the spiral cut **70**. The blind cavities **86** can also vary in cross sectional size and shape to tailor the rigidity of the connector section **32** in different directions. More specifically, the cavity or cavities **86**, only one of which is illustrated in FIG. 1A, when left hollow, provides a less rigid connector **32**. To increase the rigidity of the connector section **32**, other material can be used to partially or completely fill the cavity **86**, such as pins or rods (not illustrated) inserted in the cavity.

When implanted between vertebrae, the shock absorbing connector **32** can resiliently absorb shocks transmitted vertically between upper and lower vertebrae of the patient's spinal column. This shock absorption is related to the material properties, design, and dimensions of the connector. In general, an increased number and width of the cuts **70** will increase absorption of shocks, with more elastic, or springy compression between the vertebrae.

Preferably the connector **32** is made of metal such as titanium, cobalt chromium alloy, stainless steel, tantalum, nickel titanium or a combination thereof. These materials also can be designed to provide a device which is deformable in the elastic region of the stress/strain curve and will not plastically deform during compression.

In the embodiments illustrated herein, the number, pitch, lead, lead angle, handedness, and total vertical length of each of the spiral cuts or slots **70**, as well as the combination of multiple cuts if provided, can be varied to change the amount of compliance of the connector **32**. When a load is applied to the upper and lower plates **20**, **30**, the connector **32** will compress with each of the cuts **70** closing and the total amount of compression possible depending on the number, arrangement, and height of the cuts. The cuts **70** form spiral coils **74** between the ends of the cut, which function like springs to allow the connector **32** to be compressed. The cuts **70** may be modified to be non-uniform to provide preferential deflection in one or more bending directions. Preferential deflection is useful to provide increased anterior-posterior compliance and less lateral compliance, or the other way around.

According to one embodiment of the invention, the cuts **70** in the shock absorbing connector **32** according to any of the embodiments described herein may be manufactured by wire EDM (electrical discharge machining), molding, laser cutting, or the like. A number of cuts **70** can vary from 1 to about 50, preferably about 6 to about 20, for a vertebral body replacement. A width of the lateral cuts **70** in the direction of the height of the body **10** is about 0.01 mm to about 2 mm, preferably about 0.05 to about 1 mm.

In one embodiment of the present invention, for a cervical application, the maximum deformation of the shock absorbing body is about 0.5 to about 4 mm, and is preferably about 1 to about 2 mm. For a lumbar application, the maximum deformation of the shock absorbing body is about 1 to about 6 mm, and is preferably about 1 to about 3 mm.

Although motion between the plates **20**, **30** of the body **10** has been described herein as provided by cuts **70**, it should be understood that this motion can be provided in a number of other known manners, such as use of resilient materials, or movable joints as long as the motion is limited to the small amount of motion allowable in a patient requiring a fusion procedure including compliance or vertical motion between the plates of up to about 6 mm, rotation between the plates of less than 10 degrees, and translation between the plates of up to about 1 mm.

The body **10** can be provided in different sizes, with different plate sizes, angles between plates, lordosis angles, and heights for different patients or applications. In addition, the shock absorbing connector section **32** can be provided in different compliances for different patients. In addition, the compliance and/or height of the body **10** can be adjustable, such as by rotating an adjustment screw before or after implantation, and/or bonding portions of one or more of the portions of a coil **74**. The body **10** preferably is sized to provide substantial coverage of the vertebral surfaces. For example, in an anterior procedure, the plates **20**, **30** are preferably sized to cover at least 50 percent of the vertebral surface. In posterior or lateral procedures, the coverage of the vertebral surface may be somewhat smaller due to the small size of the access area, i.e., the posterior or lateral spacers may cover about 40 percent or more of the vertebral surface with a one or two part spacer.

Turning now to FIG. 2, a second exemplary embodiment of a body **10**, adhering to principles of the present invention, is illustrated. In contrast to the embodiment illustrated in FIGS. 1 and 1A, the body **10** illustrated in FIG. 2 includes one or more separate compliant connector spacers **90** positioned between plates **20**, **30**, rather than a connector section **32** of a plate **30**. Each of the spacers **90** includes one or more cuts **70**, which can be either planar cuts or forming one or more coils, as described above with reference to the embodi-

ment of FIGS. 1 and 1A. The adjoining surfaces of the plates **20**, **30** and the spacers **90** are also provided with rotational interlocks **80**, as described herein; while FIG. 2 suggests that the interlocks **80** are the same, differently configured interlocks can alternatively be provided for different non-adjoin-
5 adjoining surfaces, for example to prevent the spacers **90** from being assembled in a way other than that designed for a body **10** configured for the particular patient. By way of non-limiting example, a first rotational interlock, formed of rectangular ribs and recesses on adjoining surfaces of the end plates and/or the spacers, as illustrated in FIG. 1A, can be provided on the adjoining surfaces of the plate **20** and the adjacent first spacer **90**; a second rotational interlock, formed of vertically oriented cylindrical pins, can be provided on the opposite face of the first spacer **90** and the adjoining surface of the adjacent spacer or plate **30**. Because the two interlocks **80** are incompatible and do not mate, there is only a single configuration of the pieces that will permit them to be assembled into a body **10**.

FIG. 3 illustrates a third exemplary embodiment of a body **10**, adhering to principles of the present invention. In addition to the features previously described with reference to FIGS. 1-2, the embodiment illustrated in FIG. 3 includes a vertical adjustment mechanism **100** for fine tuning of the vertical size of the body **10**, either prior to or after implan-
25 tation of body **10** into a patient. While numerous configurations of the adjustment mechanism **100** can be provided, one exemplary embodiment includes a threaded post or tube **102** extending from either an upper surface **106** of the end plate **30** or a lower surface **104** of the section **32**, which mates with a correspondingly configured and threaded hole or post in the other of the end plate **30** and section **32**. Rotation of the post **102** causes the two portions of the body **10** to move toward or away from each other, and thus decreases or increases the vertical size of the body **10**, respectively. According to one version of the adjustable height vertebral body replacement an adjustment mechanism with oppositely threaded ends is inserted in the upper and lower parts **104**, **106** and is adjustable after positioning
40 in the patient.

According to one exemplary method adhering to principles of the present invention, a patient in need of a vertebral body replacement is prepped and surgical access is made to the particular vertebral body to be removed. Access to the surgical site is generally made anteriorly through the abdominal cavity for a lumbar procedure. One or more target vertebral body or bodies is removed in one of numerous manners known to those of ordinary skill in the art, between upper and lower remaining vertebral bodies in the patient's spine, and a vertebral body replacement **10**, embodying principles of the present invention, is selected based on the measurement of the spacing for proper spinal alignment. The vertebral body replacement **10** is assembled and implanted in the space created by removal of the original vertebral body or bodies. Optionally, one or more spacers **90** are assembled into the body **10**, prior to installation of the body **10** into the patient, and/or the vertical length of the body **10** is adjusted to better fit in the space. Further optionally, when the body **10** includes one or more cavities **86**, additional material is inserted into the cavity, prior to implantation of the body, to tailor the rigidity of the body **10**, or for other purposes.

While the exemplary embodiments have been described in some detail, by way of example and for clarity of understanding, those of skill in the art will recognize that a variety of modifications, adaptations, and changes may be

employed. Hence, the scope of the present invention should be limited solely by the appended claims.

What is claimed is:

1. A vertebral body replacement for replacing at least one vertebral body between remaining upper and lower vertebral bodies, the vertebral body replacement comprising:

a first end plate having an upper surface configured to engage against a surface of the upper remaining vertebral body, and a lower surface opposite the upper surface spanning the first end plate;

a second end plate having a lower surface configured to engage against a surface of the lower remaining vertebral body;

a compliant connector section between the first end plate lower surface and the second end plate lower surface, the compliant connector section comprising a plurality of separate stackable spacers each having at least one helical cut configured and arranged to permit limited rotation between the first end plate and the second end plate in an anterior/posterior direction and a lateral direction; and

a rotational interlock on the first end plate lower surface and an upper surface of at least one of the spacers, the rotational interlock being configured and arranged to inhibit rotational motion between the first end plate lower surface and the at least one spacer upper surface, wherein the rotational interlock comprises a first raised elongate portion extending in the anterior/posterior direction or the lateral direction on one of the first end plate lower surface or the at least one spacer upper surface and a first complementary elongate recess in the opposite surface.

2. The vertebral body replacement of claim **1**, wherein the second end plate includes an upper surface opposite the second end plate lower surface and spanning the second end plate, the compliant connector section located between the second end plate lower and upper surfaces.

3. The vertebral body replacement of claim **2**, wherein said rotational interlock is a first rotational interlock, and further comprising a second rotational interlock on the first end plate lower surface and the second end plate upper surface, the second rotational interlock configured and arranged to at least inhibit rotational motion between the first end plate lower surface and the second end plate upper surface.

4. The vertebral body replacement of claim **1**, wherein the compliant connector section is configured and arranged to limit motion to less than 10 degrees between said remaining vertebral bodies.

5. The vertebral body replacement of claim **1**, wherein the at least one helical cut in each of the separate stackable spacers are oppositely oriented.

6. The vertebral body replacement of claim **1**, wherein said rotational interlock is a first rotational interlock, wherein the at least one spacer has a lower surface spanning the at least one spacer, wherein the second end plate has an upper surface spanning the second end plate, and further comprising:

a second rotational interlock on the second end plate upper surface and the at least one spacer lower surface, the second rotational interlock configured and arranged to at least inhibit rotational motion between the second end plate upper surface and the at least one spacer lower surface,

wherein the second rotational interlock comprises a second raised elongate portion extending in the anterior/posterior direction or the lateral direction on one of the

11

second end plate upper surface or the at least one spacer lower surface and a second complementary elongate recess in the opposite surface.

7. The vertebral body replacement of claim 6, wherein the first and second rotational interlocks are different.

8. The vertebral body replacement of claim 1, further comprising:

an adjustment mechanism between the first and second end plates, the adjustment mechanism configured and arranged to selectively move the first and second end plates towards and away from each other.

9. The vertebral body replacement of claim 1, further comprising at least one bone ingrowth hole in at least one of the first and second end plates.

10. The vertebral body replacement of claim 1, wherein each of the first and second end plates comprise a lateral surface, and wherein the at least one bone ingrowth hole extends between said lateral surface and said surface configured to engage against a surface of a remaining vertebral body.

11. The vertebral body replacement of claim 1, wherein the vertebral body replacement is sized and shaped to replace one or more entire vertebral bodies of the human spine.

12. A vertebral body replacement for replacing at least one vertebral body between remaining upper and lower vertebral bodies, the vertebral body replacement comprising:

a first end plate having an upper surface configured to engage against a surface of the upper remaining vertebral body, and a lower surface opposite the upper surface spanning the first end plate;

a second end plate having a lower surface configured to engage against a surface of the lower remaining vertebral body;

a compliant connector section between the first end plate lower surface and the second end plate lower surface, the compliant connector section comprising a plurality of separate stackable spacers each having at least one helical cut configured and arranged to form a continuous spring coil element; and

a rotational interlock on the first end plate lower surface and an upper surface of at least one of the spacers, the rotational interlock being configured and arranged to inhibit rotational motion between the first end plate lower surface and the at least one spacer upper surface,

wherein the rotational interlock comprises a raised elongate portion extending in the anterior/posterior direction or the lateral direction on one of the first end plate lower surface or the at least one spacer upper surface and a complementary elongate recess in the opposite surface.

13. The vertebral body replacement of claim 12, wherein the vertebral body replacement is sized and shaped to replace one or more entire vertebral bodies of the human spine.

14. A vertebral body replacement for replacing at least one vertebral body between remaining upper and lower vertebral bodies, the vertebral body replacement comprising:

a first end plate having an upper surface configured to engage against a surface of the upper remaining vertebral body, and a lower surface opposite the upper surface spanning the first end plate;

a second end plate having a lower surface configured to engage against a surface of the lower remaining vertebral body and an upper surface;

a compliant connector section between the first end plate lower surface and the second end plate lower surface,

12

the compliant connector section comprising a plurality of separate stackable spacers each having at least one helical cut configured and arranged to form a continuous spring coil element; and

a rotational interlock on the second end plate upper surface and a lower surface of at least one of the spacers, the rotational interlock being configured and arranged to inhibit rotational motion between the second end plate upper surface and the at least one spacer lower surface,

wherein the rotational interlock comprises a raised elongate portion extending in the anterior/posterior direction or the lateral direction on one of the second end plate upper surface or the at least one spacer lower surface and a complementary elongate recess in the opposite surface.

15. The vertebral body replacement of claim 14, wherein the vertebral body replacement is sized and shaped to replace one or more entire vertebral bodies of the human spine.

16. A vertebral body replacement for replacing at least one vertebral body between remaining upper and lower vertebral bodies, the vertebral body replacement comprising:

a first end plate having an upper surface configured to engage against a surface of the upper remaining vertebral body, and a lower surface opposite the upper surface spanning the first end plate;

a second end plate having a lower surface configured to engage against a surface of the lower remaining vertebral body and an upper surface opposite the lower surface and spanning the second end plate;

a compliant connector section between the first end plate lower surface and the second end plate lower surface, the compliant connector section comprising a plurality of separate stackable spacers each having at least one helical cut configured and arranged to permit limited rotation between the first end plate and the second end plate in an anterior/posterior direction and a lateral direction; and

a rotational interlock on the second end plate upper surface and a lower surface of at least one of the spacers, the rotational interlock being configured and arranged to inhibit rotational motion between the second end plate upper surface and the at least one spacer lower surface,

wherein the rotational interlock comprises a raised elongate portion extending in the anterior/posterior direction or the lateral direction on one of the second end plate upper surface or the at least one spacer lower surface and a complementary elongate recess in the opposite surface.

17. The vertebral body replacement of claim 16, wherein the compliant connector section is located between the second end plate lower and upper surfaces.

18. The vertebral body replacement of claim 16, wherein the compliant connector section is configured and arranged to limit motion to less than 10 degrees between said remaining vertebral bodies.

19. The vertebral body replacement of claim 16, wherein the at least one helical cut in each of the separate stackable spacers are oppositely oriented.

20. The vertebral body replacement of claim 16, wherein said rotational interlock is a first rotational interlock, and further comprising a second rotational interlock on the first end plate lower surface and the second end plate upper surface, the second rotational interlock configured and

13

arranged to at least inhibit rotational motion between the first end plate lower surface and the second end plate upper surface.

21. The vertebral body replacement of claim 16, further comprising:

an adjustment mechanism between the first and second end plates, the adjustment mechanism configured and arranged to selectively move the first and second end plates towards and away from each other.

22. The vertebral body replacement of claim 16, further comprising at least one bone ingrowth hole in at least one of the first and second end plates.

23. The vertebral body replacement of claim 16, wherein each of the first and second end plates comprise a lateral surface, and wherein the at least one bone ingrowth hole extends between said lateral surface and said surface configured to engage against a surface of a remaining vertebral body.

24. The vertebral body replacement of claim 16, wherein the vertebral body replacement is sized and shaped to replace one or more entire vertebral bodies of the human spine.

25. A vertebral body replacement for replacing at least one vertebral body between remaining upper and lower vertebral bodies, the vertebral body replacement comprising:

a first end plate having an upper surface configured to engage against a surface of the upper remaining ver-

14

tebral body and at least one elongated fin on the upper surface configured to enter a slot cut in the upper remaining vertebral body;

a second end plate having a lower surface configured to engage against a surface of the lower remaining vertebral body and at least one elongated fin on the lower surface configured to enter a slot cut in the lower remaining vertebral body;

a compliant connector section between the first end plate and the second end plate, the compliant connector section comprising a plurality of separate stackable spacers each having at least one helical cut configured and arranged to permit limited rotation between the first end plate and the second end plate in an anterior/posterior direction and a lateral direction, wherein the compliant connector section is configured and arranged to limit motion to less than 10 degrees between said remaining vertebrae.

26. The vertebral body replacement of claim 25, wherein the upper and lower surfaces have less than 10 percent comprising holes.

27. The vertebral body replacement of claim 25, further comprising one or more holes in the first and second end plates configured to receive screws extending through the plates and into the bone.

* * * * *