

US00RE47397E

(19) **United States**
(12) **Reissued Patent**
Waldman et al.

(10) **Patent Number: US RE47,397 E**
(45) **Date of Reissued Patent: May 21, 2019**

(54) **FABRIC WITH EQUAL MODULUS IN MULTIPLE DIRECTIONS**

3,069,885 A 12/1962 Cooper et al.
3,456,193 A 7/1969 Muñoz
3,459,193 A 8/1969 Krieger
3,733,859 A * 5/1973 Wittmann D04B 21/12
66/193

(71) Applicant: **GLOBAL TRADEMARKS, LLC**,
Stockertown, PA (US)

(Continued)

(72) Inventors: **Mark Waldman**, New Hope, PA (US);
Mark Lazarus, Holland, PA (US)

FOREIGN PATENT DOCUMENTS

(73) Assignee: **Global Trademarks, LLC**,
Stockertown, PA (US)

CN 1326519 A 12/2001
CN 101437996 A 5/2009

(Continued)

(21) Appl. No.: **15/160,681**

(22) Filed: **May 20, 2016**

OTHER PUBLICATIONS

Related U.S. Patent Documents

Taiwanese Examination Report dated Aug. 3, 2010 from corresponding Taiwan Patent Application No. 100127525, 9 pages.

Reissue of:

(Continued)

(64) Patent No.: **8,726,700**
Issued: **May 20, 2014**
Appl. No.: **13/197,617**
Filed: **Aug. 3, 2011**

Primary Examiner — Patricia L Engle
(74) *Attorney, Agent, or Firm* — Ohlandt, Greeley, Ruggiero & Perle, L.L.P.

U.S. Applications:

(60) Provisional application No. 61/370,295, filed on Aug. 3, 2010.

(57) **ABSTRACT**

(51) **Int. Cl.**
D04B 1/22 (2006.01)
D04B 21/20 (2006.01)
D04B 21/18 (2006.01)

A garment including a fabric covering a portion of a body of a wearer. The fabric comprises an isotropic material having a first direction with a first modulus of elasticity, and a second direction that is perpendicular to the first direction. The second direction has a second modulus of elasticity and a third direction that is at an angle of 45 degrees to the first direction and the second direction. The third direction has a third modulus of elasticity. The first modulus of elasticity, the second modulus of elasticity and the third modulus of elasticity are within the same ranges of magnitudes of modulus of elasticity to form an isotropic fabric for such garment.

(52) **U.S. Cl.**
CPC **D04B 21/207** (2013.01); **D04B 21/18** (2013.01); **Y10T 442/413** (2015.04)

(58) **Field of Classification Search**
CPC D04B 21/07; D04B 21/18; Y10T 442/413
See application file for complete search history.

(56) **References Cited**

U.S. PATENT DOCUMENTS

23 Claims, 6 Drawing Sheets

1,855,033 A 4/1932 Spiers

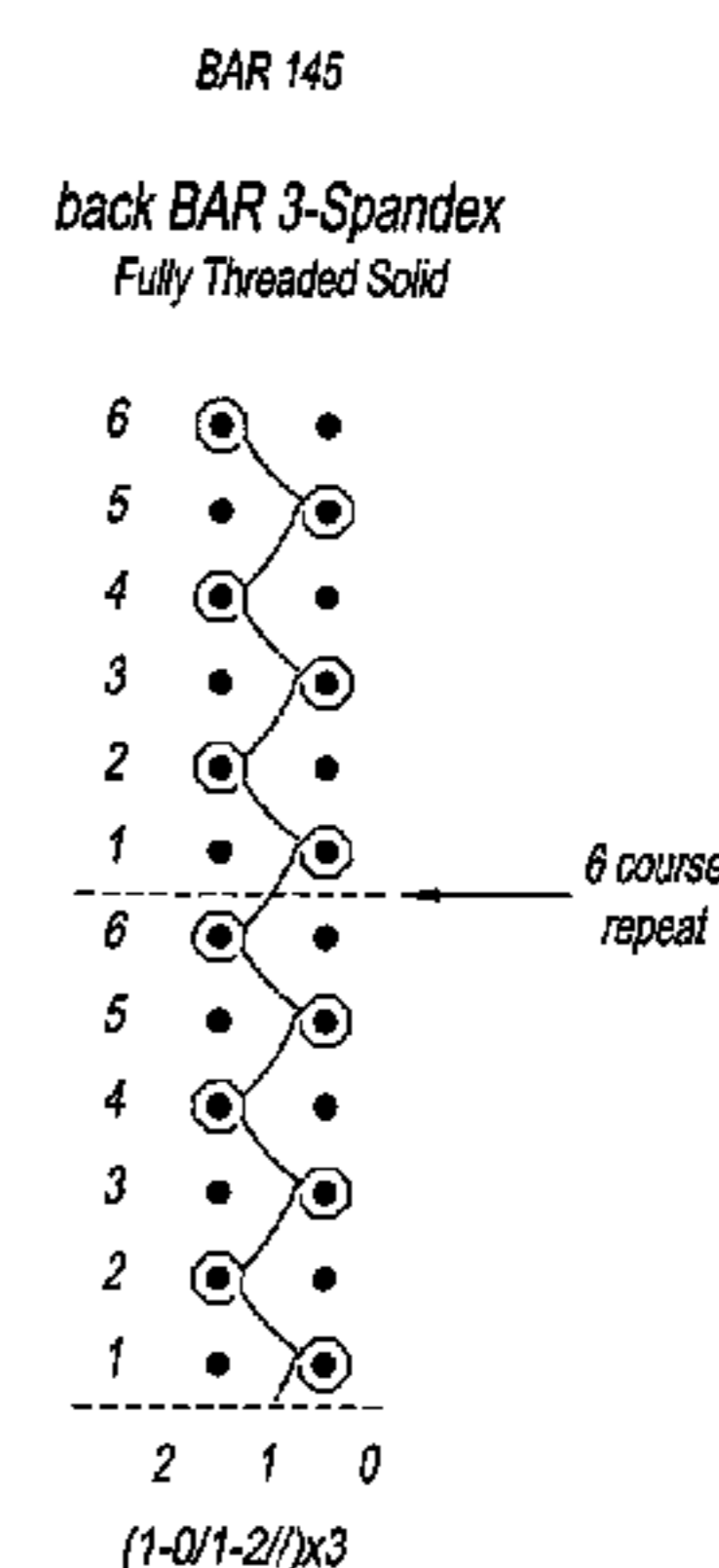
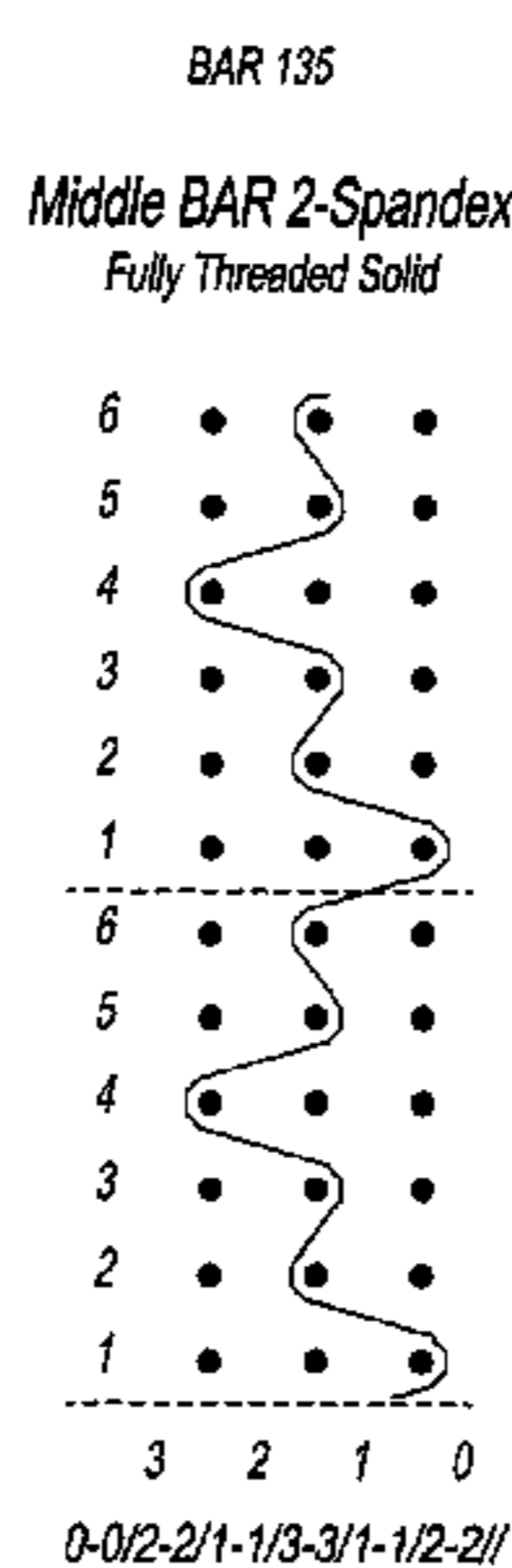
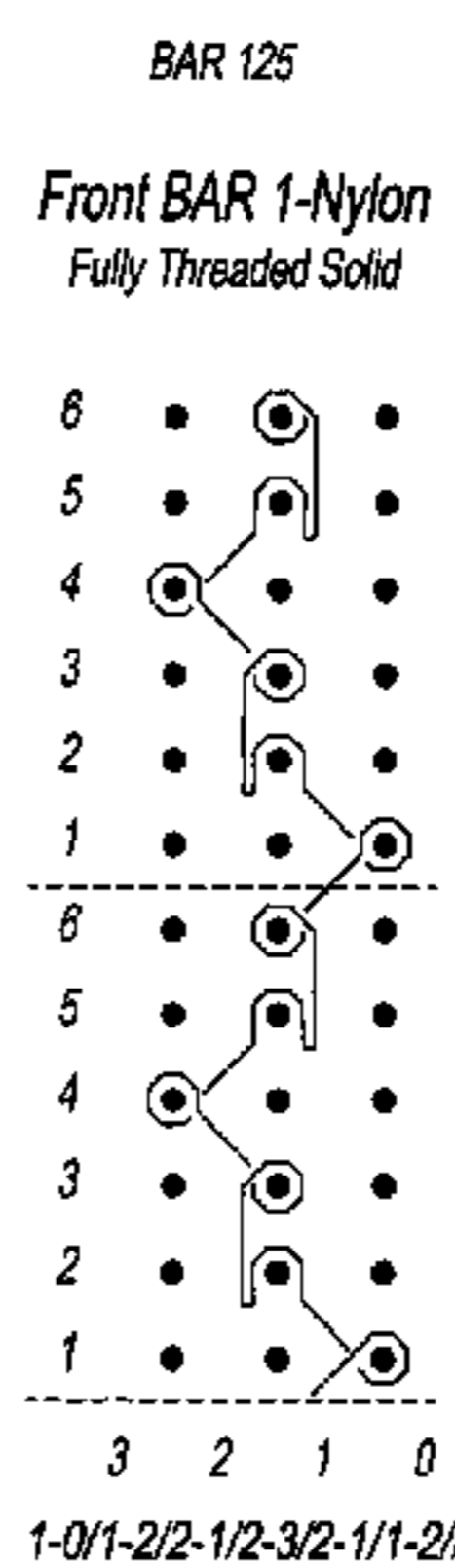
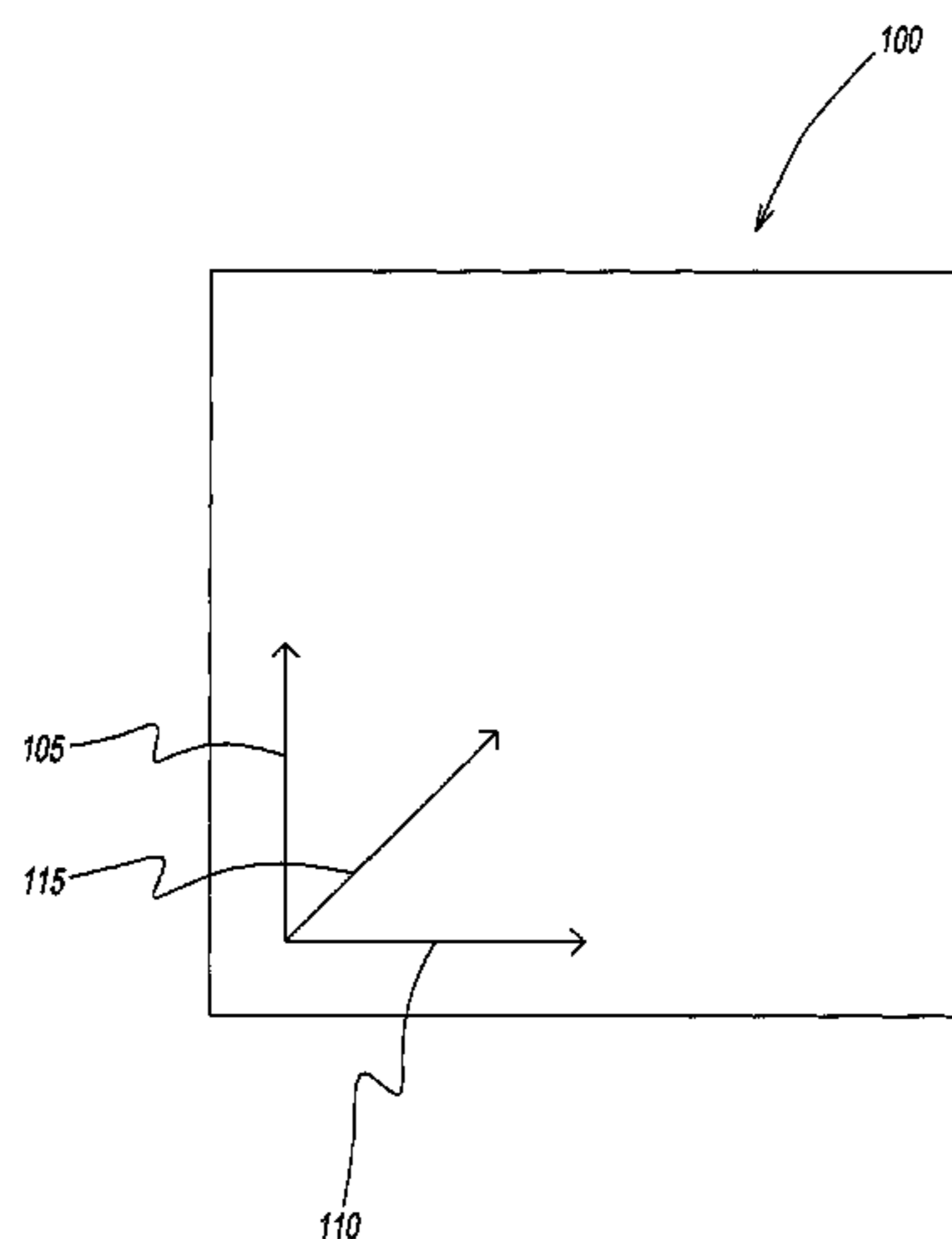

(56)

References Cited

U.S. PATENT DOCUMENTS

3,772,127	A	11/1973	James	
4,044,575	A	8/1977	Krug	
4,103,485	A	8/1978	Brües	
4,270,368	A	6/1981	Ragoza et al.	
4,786,549	A	11/1988	Richards	
4,817,400	A	4/1989	Baesgen et al.	
4,909,049	A	3/1990	Baesgen et al.	
5,250,351	A	10/1993	Kondou et al.	
5,359,732	A	11/1994	Waldman et al.	
5,542,269	A	8/1996	Richards	
5,596,888	A	1/1997	McLarty, III et al.	
5,657,648	A	8/1997	Ives et al.	
5,727,943	A	4/1998	Bernhardt	
5,765,401	A	6/1998	Ives et al.	
5,783,278	A	7/1998	Nishimura et al.	428/102
5,987,933	A	11/1999	Metzler	
6,223,782	B1	5/2001	Watkins	
6,408,656	B1	6/2002	Ory et al.	
6,698,252	B1	3/2004	Norris et al.	
6,705,129	B2	3/2004	Pot d'Or	68/8
6,722,164	B1	4/2004	Ives et al.	
6,745,601	B2	6/2004	Pierelli	
6,971,252	B2	12/2005	Therin et al.	
7,174,749	B2	2/2007	Ternon et al.	66/192
7,503,941	B2	3/2009	Hamano et al.	
7,743,476	B2	6/2010	Rock et al.	28/159
8,065,894	B2	11/2011	Yanagi et al.	
2002/0184925	A1	12/2002	McClellan et al.	
2003/0150243	A1	8/2003	Pot d'Or et al.	
2004/0000173	A1	1/2004	Keller	
2005/0112975	A1	5/2005	McMurray	
2006/0107701	A1	5/2006	Ternon et al.	
2007/0082579	A1*	4/2007	Baran	A41C 3/00 450/77
2008/0189824	A1	8/2008	Rock et al.	
2008/0208360	A1	8/2008	Meneghin et al.	
2009/0049579	A1	2/2009	Roberts	

FOREIGN PATENT DOCUMENTS

EP	1 085 115	A2	3/2001
GB	1012427		12/1965
JP	2003/166152	A	6/2003
WO	2009/133821	A1	11/2009
WO	2010/061188	A1	6/2010

OTHER PUBLICATIONS

European Examination Report dated Oct. 4, 2016 from corresponding European Application No. 11 815 282.6, 8 pages.

Chinese First Office Action dated Feb. 4, 2017 from corresponding Chinese Patent Application No. 201610166402.8, 21 pages.

International Preliminary Report on Patentability dated Jul. 1, 2012 corresponding to International Patent Application No. PCT/US2011/046468, 32 pages.

International Search Report for Corresponding to International Patent Application No. PCT/US2011/046468 dated Jan. 11, 2012, 3 pages.

Chinese Second Notification of Office Action dated Oct. 17, 2014 from corresponding Chinese Patent Application No. 201180038184.5, 4 pages.

Chinese Office Action dated Dec. 17, 2013 corresponding to Chinese Patent Application No. 201180038184.5, 25 pages.

European Extended Search Report dated Jul. 29, 2015 from corresponding European Patent Application No. 11815282.6, 9 pages.

Taiwan Search Report dated Jul. 2, 2014 from corresponding Taiwan Patent Application No. 100127525, 1 pages.

Written Opinion for Corresponding to International Patent Application No. PCT/US2011/046468 dated Jan. 11, 2012, 11 pages.

Summons to attend Oral Proceeding from corresponding European Patent Application No. 11815282.6, dated Nov. 21, 2017, 10 pages.

* cited by examiner

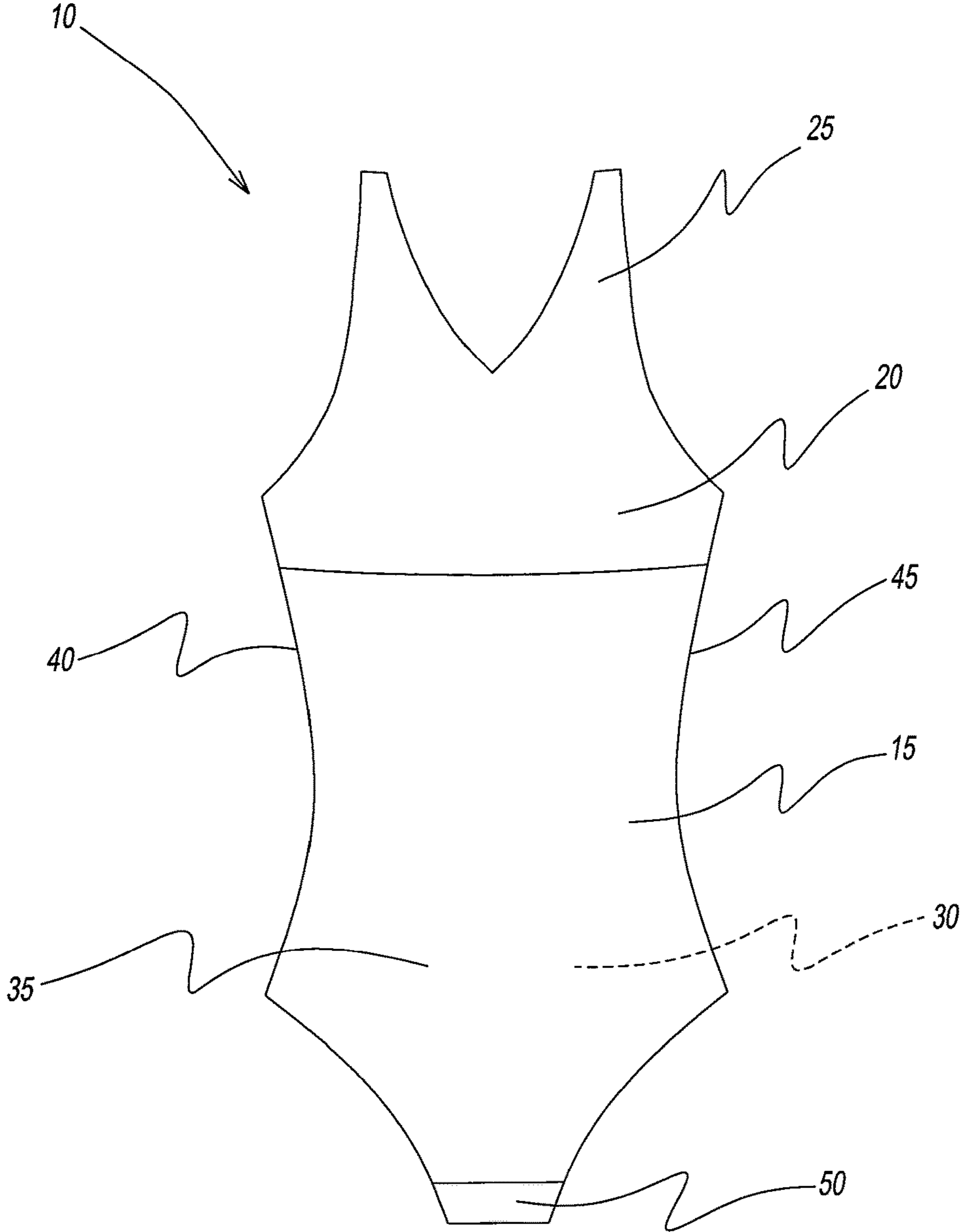

FIG. 1

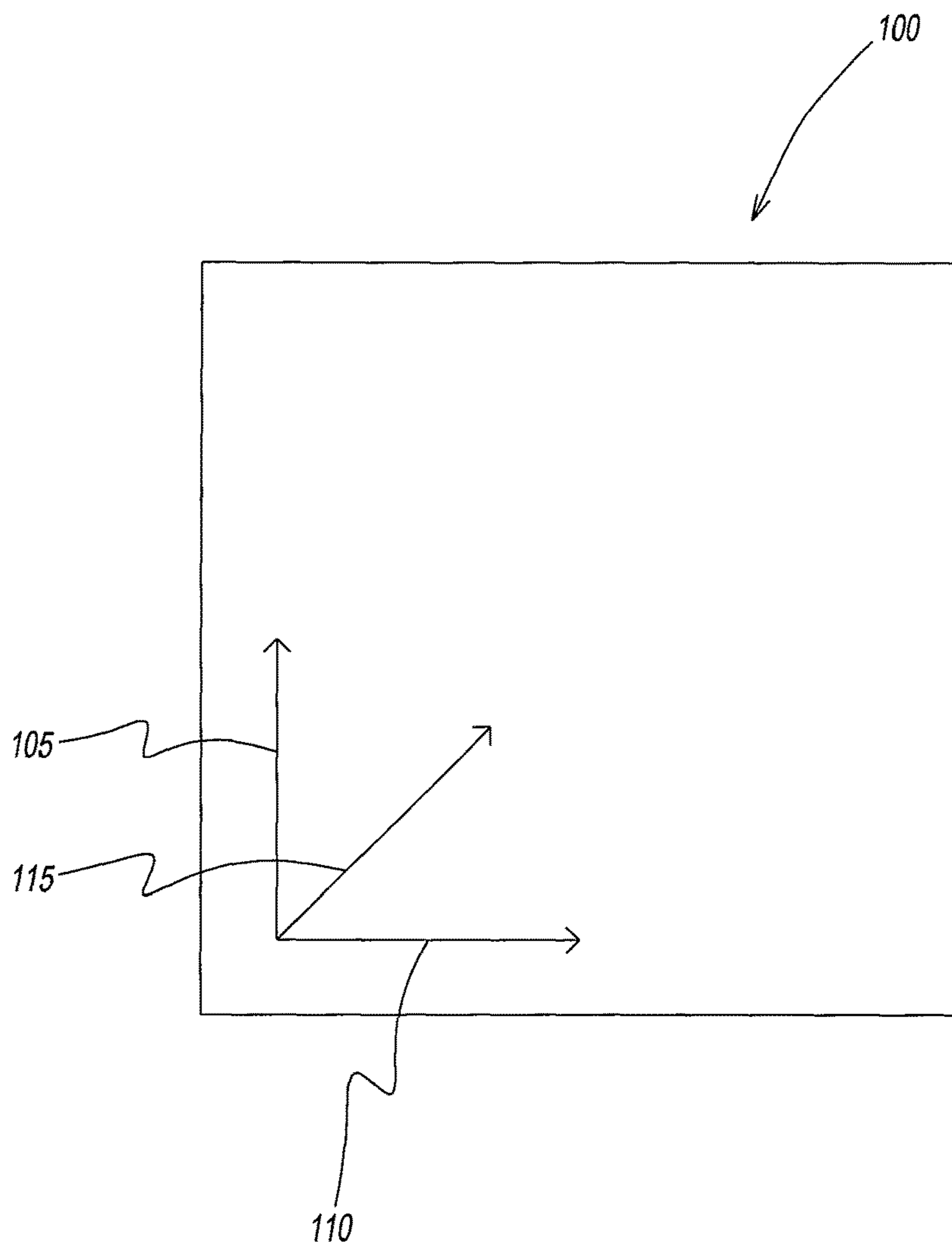

FIG. 2

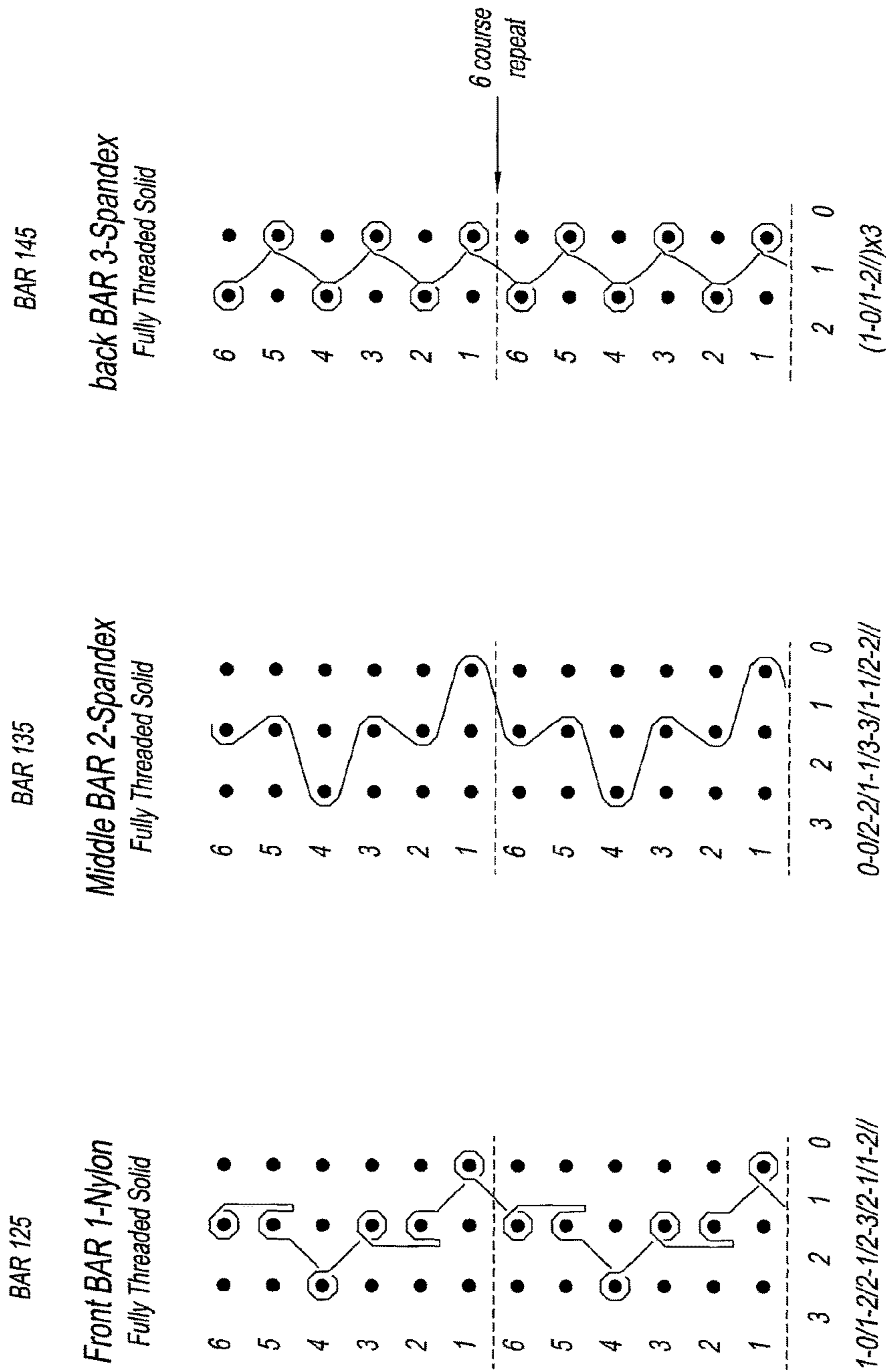

FIG. 3

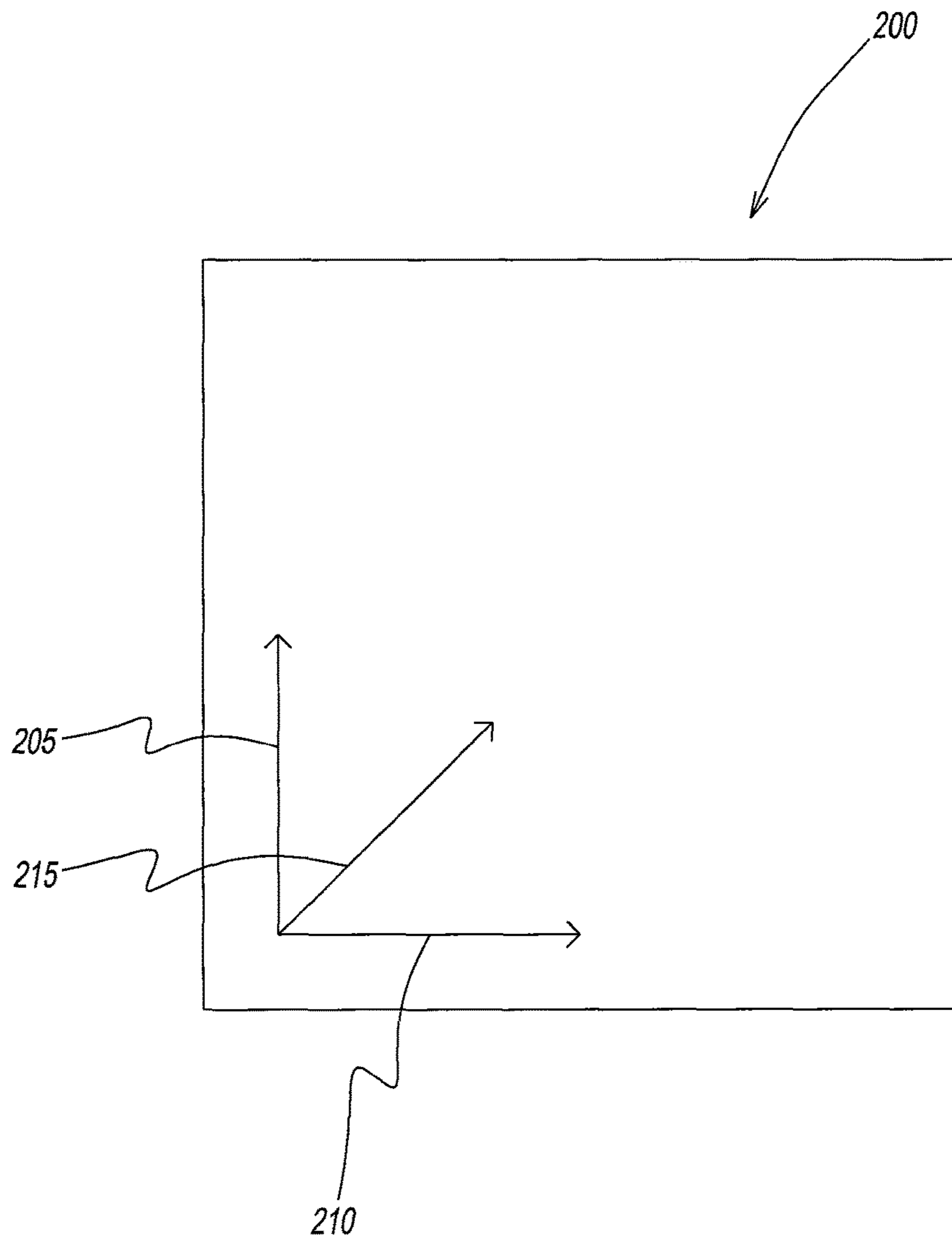

FIG. 4

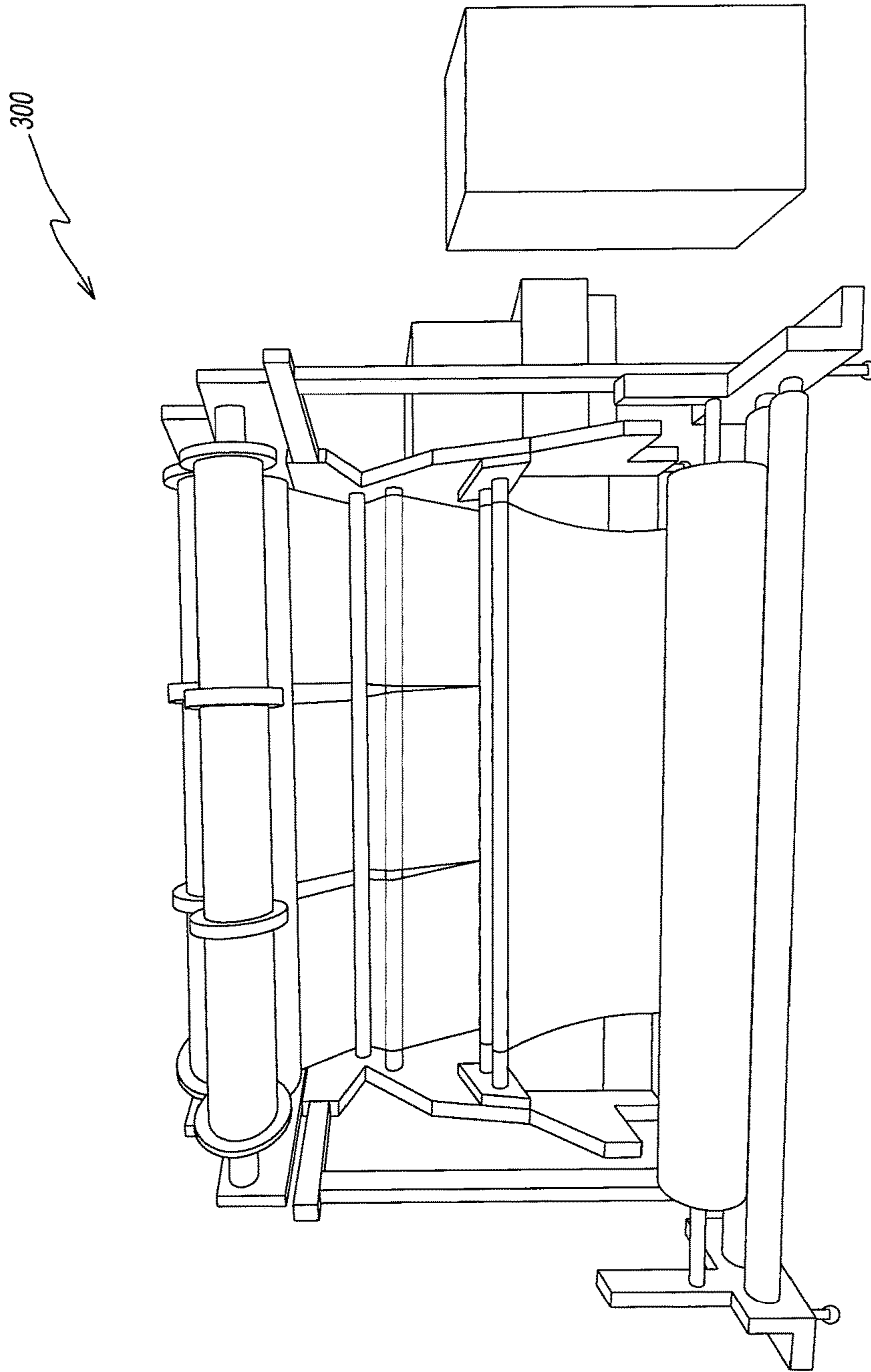

FIG. 5a

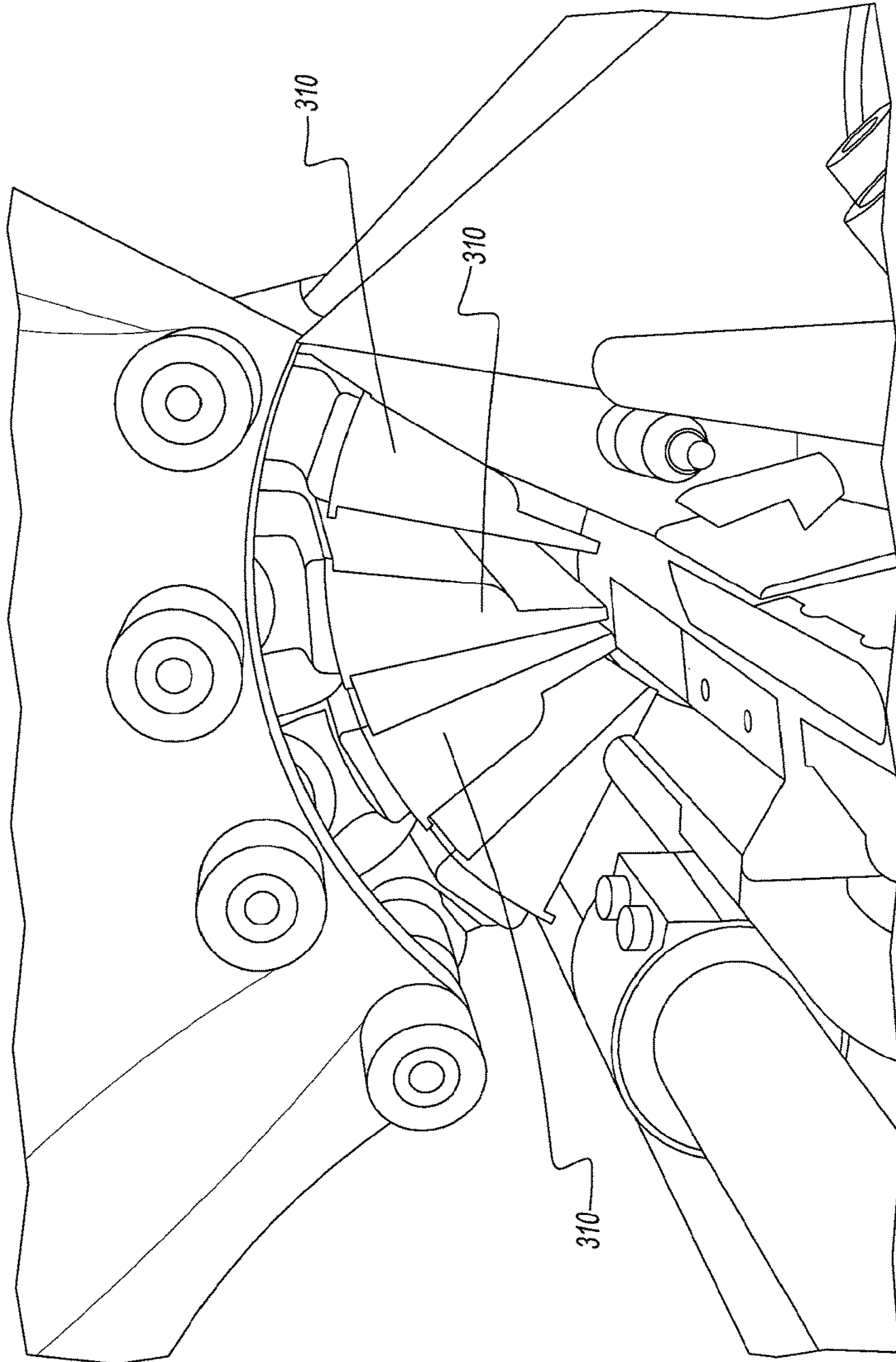

FIG. 5b

FABRIC WITH EQUAL MODULUS IN MULTIPLE DIRECTIONS

Matter enclosed in heavy brackets [] appears in the original patent but forms no part of this reissue specification; matter printed in italics indicates the additions made by reissue; a claim printed with strikethrough indicates that the claim was canceled, disclaimed, or held invalid by a prior post-patent action or proceeding.

CROSS-REFERENCE TO RELATED APPLICATION

This application claims the benefit of U.S. Provisional Application No. 61/370,295 filed on Aug. 3, 2010, which is incorporated by reference herein.

BACKGROUND OF THE DISCLOSURE

1. Field of the Disclosure

The present disclosure relates generally to a fabric having substantially isotropic stretchability and uniform modulus in multiple directions. More particularly, the present disclosure relates to an elasticized fabric having isotropic stretchability and uniform modulus in all directions that is incorporated into a garment or a garment that is constructed entirely of such isotropic fabric.

2. Description of Related Art

There are several different types of stretch fabrics being used today for swimwear, shapewear, garment liner, or undergarment. These fabrics generally fall into the following classifications: a nylon/spandex combination in a tricot-type knit or circular knit, a nylon/spandex combination in a raschel-type knit, a cotton/spandex combination in a circular knit, and a polyester/spandex combination. Each of these combinations and knits has specific applications and specific characteristics.

The nylon/spandex combination in a tricot construction generally includes 80% nylon and 20% spandex, usually LYCRA (a registered trademark of Invista, a subsidiary of Koch Industries, Inc.). This fabric is commonly used for its four-way stretchability, i.e. the ability to stretch in both the length and width directions of the fabric. The advantage of this type stretch is that it permits the garment to fit different shapes and sizes without substantial modification to the pattern of the garment.

The nylon/spandex combination in a Raschel-type construction is characterized by a combination of 85% nylon and 15% spandex. The stretch is typically significantly greater in one direction than the stretch in the other. Raschel-type knitting commonly used in swimwear, provides a fabric with a much greater stretch in the warp direction as compared to the tricot type construction.

The cotton/spandex combination generally includes 90% cotton and 10% spandex. Also included within this classification is a poly/cotton/spandex mix made of 45% polyester, 45% cotton and 10% spandex. These fabrics are often used for exercise wear, such as leotards and the like. The cotton is used for perspiration absorption. Also, the cotton within the blend provides a softer feel to the fabric.

The polyester/spandex combination is a lightweight and less expensive alternative to the nylon/spandex or cotton/spandex combinations. This fabric material is primarily used in the United States in active sportswear and intimate apparel.

There are many variations and blends of spandex for use in swimwear, shaping garments, liners or the like. Spandex is generally defined as a synthetic elastomeric fiber having a very high elasticity to break point (up to approximately 500% to 600%) and a high recovery from stretching. Though the chemistry is very complex, basically spandex is a series of elastomeric products including hard and soft segments and cross linking between the same. The fibers produced are generally white, clear or bright depending on the level of titanium dioxide added, are not dyeable and are stronger and lighter than rubber. The properties of spandex include high stretch, low set (the ability to spring back to its original shape concluded after repeated stretching), high durability, easiness of cleaning, uniformity and versatility.

However, none of these fabrics offers substantially isotropic stretchability and equal modulus in all directions.

Accordingly, there is a need for a fabric that can be used in swimwear, undergarment, garment liner and shapewear that is substantially isotropic and offers equal modulus in all directions to provide a balanced degree of compression, shaping and comfort to the wearer.

SUMMARY OF THE DISCLOSURE

The present disclosure provides for a fabric that offers substantially isotropic stretchability and equal modulus in all directions to offer a balanced degree of comfort and control to the wearer of a garment made with such a fabric.

The fabric includes at least one layer of material that lay in a single plane. The material comprises a first direction having a first modulus of elasticity, a second direction that is perpendicular to the first direction. The second direction has a second modulus of elasticity and a third direction that is at an angle of 45 degrees to the first direction and the second direction. The third direction has a third modulus of elasticity. The first modulus of elasticity, the second modulus of elasticity and the third modulus of elasticity are within the same ranges of magnitude of modulus.

The garment includes a fabric covering a portion of a body of a wearer. The wherein the fabric comprises an isotropic material having a first direction having a first modulus of elasticity, a second direction that is perpendicular to the first direction. The second direction has a second modulus of elasticity. A third direction that is at an angle of 45 degrees to the first direction and the second direction has a third modulus of elasticity. The first modulus of elasticity, the second modulus of elasticity and the third modulus of elasticity are within the same ranges of magnitudes of modulus of elasticity.

BRIEF DESCRIPTION OF THE DRAWINGS

FIG. 1 illustrates a swimsuit incorporating a fabric according to the present disclosure;

FIG. 2 illustrates an exemplary fabric according to a first embodiment of the present disclosure;

FIG. 3 illustrates a stitch pattern of the fabric according to the first embodiment;

FIG. 4 shows an exemplary fabric according to a second embodiment of the present disclosure; and

FIGS. 5a and 5b show a photograph of an exemplary machine that is used to knit the isotropic fabric of FIG. 2.

DETAILED DESCRIPTION OF THE DISCLOSURE

Referring to the drawings and, in particular to FIG. 1, there is illustrated a swimsuit that is generally referred to by

reference numeral **10**. The swimsuit **10** includes a torso portion **15** and a bra portion **20**. Torso portion **15** may include any number of panels, such as, a front panel **35** and rear or back panel **30** or a single panel. Front panel **35** and rear panel **30** are joined by seams **40** and **45** and at crotch **50**. Front panel **35** may be formed by a single panel or any number of panel or sections, as desired. Similarly, rear panel **30** may also be divided into separate panels or portions. Bra portion **20** has one or more shoulder straps **25**, depending upon the style of the swimming suit. The fabric of the present disclosure provides support and added comfort to the various areas of the swimsuit. While a swimming suit is shown in FIG. 1, other types of garments such as shapewear, undergarment, liner and bra frame construction could also incorporate the fabric of the present disclosure. Such other types of garments could include the fabric of the present disclosure as either a liner, as the garment itself or as a portion of the garment.

The present disclosure generally contemplates a fabric incorporated into a swimsuit or other type of garment, in which the fabric has specified properties. The fabric may be incorporated in only a part of the torso portion **15**, bra portion **20**, such as a front panel **35** or at shoulder straps, respectively, or may comprise the entire swimsuit **10**.

Swimsuit **10** is made from a fabric that has a generally isotropic stretchability. Isotropic stretchability means that the fabric from which swimsuit **10** is made is capable of expanding or elongating in equal amounts in the length and width directions of the fabric as well as along the diagonal direction at an angle of 45° relative to the width and length directions of the fabric. This isotropic stretchability is characterized by a high degree of elasticity and modulus which is provided for purposes of comfort of the wearer. By having an equal or substantially equal modulus in all directions, the wearer will not experience uncomfortable restrictions to stretching during movement. Were there a higher modulus across the body of the wearer relative to the length, for example, the wearer could be uncomfortably restricted at the waist and the appearance of the garment on the wearer may be compromised.

One embodiment of the preferred fabric according to the present disclosure is generally illustrated in FIG. 2. The fabric generally referenced by reference numeral **100** is produced by a warp knitting method. Fabric **100** has a width direction **105**, a length direction **110** that is perpendicular to width direction **105**, and a diagonal direction **115** that is at an angle of 45° relative to width direction **105** and length direction **110**. When fabric **100** is tested in three different directions, width direction **105**, length direction **110** and at an angle of 45° relative to width direction **105** and length direction **110**, fabric **100** exhibits isotropic stretchability and equal modulus in each direction. Significantly, isotropic stretchability and equal modulus exists independent of how fabric **100** is cut and sewn into the garment or garment portion.

FIG. 3 illustrates a stitch pattern for the isotropic fabric of FIG. 2. Referring to FIG. 2, fabric **100** is knitted using three different yarns. Fabric **100** is knitted using three integrally knitted bars, bar **125**, bar **145** and bar **135** knitted between bar **125** and bar **145**. Bar **125**, or front bar is made from nylon thread, such as a flat filament nylon. The repeating stitch pattern is knitted on a warp knitting machine is 1-0/1-2/2-1/2-3/2-1/1-2. This pattern then repeats. Bar **135**, or middle bar is made from spandex. Bar **135** is a loose knit as seen in FIG. 3, in comparison to bar **125**. Bar **135** has a repeating pattern that is knitted on a warp knitting machine. Stitch pattern of bar **135** is 0-0/2-2/1-1/3-3/1-1/2-2/. By not wrapping around pins of knitting machine, yarns of bar **135**

are knitted between yarns of bar **125** and yarns of bar **145**. Bar **145**, or back bar, is knitted using spandex. The pattern of bar **145** is 1-0/1-2 repeated three times. While fabric **100** is shown as being knitted with three different bars **125**, **135** and **145**, two different yarns could also be used in three different knitted bars to also achieve the isotropic property of fabric **100**.

After three bars, bar **125**, **135** and **145** are knitted, fabric **100** is heated and intersecting yarns of bars **135** and **145** adhere to adjacent threads to create an integrated and isotropic fabric. Other factors, such as denier, type of yarn, heat application profile, and dyeing and finish affect the isotropic properties of the fabric.

Further, in fabric **100** there is a relationship between the stretch and modulus characteristics that produce a “wearing stretch” as experienced by the wearer. The modulus affects the “wearing stretch” function of a fabric in that the higher the modulus, the more resistant the fabric material will be to linear stretch. If the modulus is too high, the suit will not be comfortable or properly fit a range of body sizes. Accordingly, garments made from fabric **100** will fit a variety of different body types within a size because isotropic compression will fit like second skin, fitting and functioning on the body uniformly. When the modulus is not isotropic, the wearer will feel the fabric putting more pressure on the body in the direction with the higher modulus, thus creating discomfort.

Fabric **100** of the first embodiment includes a combination of yarns in combination with an elastomeric yarn, such as, spandex, and having a weight of approximately 7.95 or alternatively 7.5 to 8.4 ounces per square yard. To achieve isotropic properties, Fabric A preferably has a percentage of elastomeric yarn in a range of from 8% to 60% and a range of non-elastomeric yarn, such as nylon, of from 40% to 92%. A minimum of 16% elastomeric fabric yarn is preferred. These percentages of yarn represent percentages of weight of the fabric **100**. Therefore, a low denier yarn will represent a lower percentage of such yarn in a fabric **100** in comparison to a high denier yarn. Further, the yarns in combination with elastomeric yarn are preferably nylon, polyester, cotton, rayon, polypropylene, for example, or any similar yarn that is a hard yarn, a non-elastomeric yarn.

Table 1 below describes a fabric **100** that is isotropic and has equal modulus in the horizontal, vertical and 45° diagonal directions. The third column represents the ranges of acceptability for an isotropic fabric of the given content. The inclusion of elastomeric yarns ensures that there is a substantial amount of power in retraction of the garments indicated by a flatter stress-strain curve of the fabric through the fit zone. The flatter stress-strain curve of the fabric provides for a broader range of comfort at the fit point of 30% stretch and for comfort at 70% stretch of the fabric.

TABLE 1

	Fabric 100	Industry Standard Range
Actual Weight (oz/yard ²)	7.95	7.5-8.4
Content	8% to 60% Elastomer and 40% to 92% Hard Yarns	8% to 60% Elastomer and 40% to 92% Hard Yarns
<u>Zwick Stretch</u>		
Length	135%	112%-137%
Width	130%	112%-137%
45°	114%	112%-137%

5

TABLE 1-continued

	Fabric 100	Industry Standard Range
<u>Length Modulus</u>		
@30%	3.36 (lbs of holding power)	2.77-3.38 (lbs of holding power)
@50%	6.33	5.85-7.15
@70%	9.61	9.31-11.37
<u>Width Modulus</u>		
@30%	3.01	2.77-3.38
@50%	6.67	5.85-7.15
@70%	10.34	9.31-11.37
<u>45° Modulus</u>		
@30%	2.78	2.77-3.38
@50%	6.44	5.85-7.15
@70%	11.06	9.31-11.37

Specific readings for the modulus were taken at a thirty percent (30%) stretch or elongation point for the length, width and diagonal directions. For example, at 30% elongation, the modulus of fabric **100**, in length direction **110**, width direction **105** and 45° diagonal direction **115** is in a range of from 2.7 to 3.38 lbs of holding power. This range represents an industry standard. This stretch point is considered to be a normal fit position for a swimsuit. At the fit point, the fabric **100** or a swimsuit **10** made of the fabric **100** of the present disclosure is cut to have a substantially equal holding power in the length, width and 45° directions. Because of the flat stress-strain curve, at 50% stretch and 70% stretch, the swimsuit is still a comfortable fit during all ranges of movement. Significantly, different sizes of individuals can wear the same suit. For example, a woman who is five feet tall and a woman who is six feet tall can both be a size eight and still wear the same suit and be comfortable across a wide range of movements. Also, fabric **100** was made in the same color (black) as a control. Other conditions, such as temperature and humidity, were maintained constant during the test.

The fabric for the swimsuit of the present disclosure can be defined by applying a stretching test. Specifically, a stretching test using the fabrics and tensile cartridge of a Zwick Microprocessor DYP type machine can be used to determine the constant rate of extension (CRE) of the fabric at a specific load. The following chart shows the results of a CRE comparison loop method test performed on the Zwick machine using a 3 inch wide and a 10 inch loop and a 20 pound effective load. The data for the fabric of the present disclosure is compared to two standard swimsuit fabrics using the same testing procedure.

Fabric **100** exhibits test stretch values that are within the Industry Standard Range of the adjacent column. Fabric **[200]** **100** stretches in the range of 112% to 137% of its original width direction **105**, length direction **110** and in a 45° diagonal direction **115** relative to width direction **105** and length direction **110**. (As measured by the Zwick machine in accordance with the above noted procedure and using the first flex reading.) The percentage stretching for length of 135%, width of 130% and at a 45 degree angle of 114% are within the acceptable range to be considered isotropic. Further, at 30% elongation for width direction **105**, length direction **110**, and 45° diagonal direction **115**, respectively, the amount of holding power or modulus in each direction is within the same acceptable range as iden-

6

tified by the Industry Standard Range. For each direction, the modulus or amount of holding power is within a range of 2.77 pounds to 3.38 pound of holding power.

Similarly, at 50% and 70% elongation for width direction **105**, length direction **110** and 45° direction **115**, the amount of holding power or modulus at each direction is within the same acceptable range of the Industry Standard as shown in Table 1. For each direction at 50% and at 70%, the modulus or amount of holding power is within a range of 5.85 pounds to 7.15 pounds and 9.31 to 11.37 pounds of holding power, respectively. Significantly, the holding power of fabric **100** at 45° diagonal direction at all levels of stretch or elongation is also within the same acceptable standardized range as exhibited in the length and width directions. (As measured by the Zwick machine in accordance with the above noted procedure and using the first flex reading.) Accordingly, fabric **100** is an isotropic fabric.

One of the benefits of the fabric **100** is the degree of compression and control that it offers. Due to fabric **100**'s excellent performance in retraction, fabric **100** is excellent for use in control or shaping garments or as the primary material for a control or shaping garment. While fabric **100** represents an isotropic fabric, other fabrics with similar compositions are within the scope of this disclosure.

A second embodiment of a fabric of the present disclosure, fabric **200**, exhibits isotropic stretchability and equal modulus in the length direction, width direction and 45° diagonal direction, and is shown at FIG. 4, and is generally referenced by reference numeral **200**. Fabric **200** has a width direction **205**, a length direction **210** and a 45° diagonal direction **215** that is at an angle of 45° relative to width direction **105** and length direction **210**. Fabric **200** is a [warp] circular knit fabric knitted on a circular knitting machine. Fabric **200** is a jersey construction. Fabric **200** includes nylon, such as textured filament nylon, and a secondary elastomeric yarn. Elastomeric yarn of fabric B is a modified polyurethane. Elastomeric yarn of fabric B can also be spandex. Fabric **200** has a percentage of nylon ranging from 50 to 85% and an elastomer, elastomeric yarn, ranging from 15% to 50%. As an alternative to nylon, yarns such as polyester, cotton, rayon, polypropylene or any other hard yarn, a non-elastic yarn, could also be used along with the elastomeric yarn. Elastomeric yarn has a lower and flatter stress strain curve relative to fabric **100**. The lower and flatter stress-strain curve indicates a lower level of power in retraction for fabric **200** at all levels of elongation in comparison to fabric **100**.

TABLE 2

	Fabric 200	Industry Standard Range
Actual Weight (oz/yard ²)	8.4	7.98-8.82
Content	50% to 85% Nylon & 15% to 50% Elastomer	50% to 85% Nylon & 15% to 50% Elastomer
<u>Zwick Stretch</u>		
Length	221%	193%-237%
Width	233%	193%-237%
45°	200%	193%-237%
<u>Length Modulus</u>		
@30%	0.70	0.69-0.85
@50%	1.34	1.33-1.64
@70%	1.99	1.98-2.42

TABLE 2-continued

	Fabric 200	Industry Standard Range
Width Modulus		
@30%	0.73	0.69-0.85
@50%	1.93	1.33-1.64
@70%	2.02	1.98-2.42
45° Modulus		
@30%	0.84	0.69-0.85
@50%	1.64	1.33-1.64
@70%	2.42	1.98-2.42

One of the benefits of fabric **200** is that it offers a great degree of comfort because it has a lower modulus and stretches easily with the wearer. Fabric B is appropriate for shaping swimwear, underwear, and lighter control fabric in comparison to Fabric A. During water fitness activities, for example, the fabric stretch is often greater than 70%; however, due to the flatter stress-strain curve, shaping and comfort exist over a wider stretch range to preserve comfort for the wearer.

Fabric **200** in accordance with the present disclosure stretches in the range of 193% to 237% of its original width direction **205**, length direction **210** and in a 45° diagonal direction **215** relative to width direction **205** and length direction **210**. (As measured by the Zwick machine in accordance with the above noted procedure and using the first flex reading.) At 30% elongation, width direction **205**, length direction **210** and 45° diagonal direction **215**, each has a modulus within a range from 0.69 to 0.85 lbs of holding power. At 50% elongation, width direction **205**, length direction **210** and in a 45° diagonal direction **215** of fabric **200**, each has a modulus within a range from 1.33 to 1.64 lbs of holding power. At 70% elongation, width direction **205**, length direction **210** and 45° diagonal direction **215** of fabric **200**, each has a modulus within a range from 1.98 to 2.42 lbs of holding power. Thus, at all levels of elongation, the modulus or pounds of holding power are within the Industry Standard Range.

The fabrics **100** and **200** of the present disclosure may be included in only certain portions of the garment, for example, swimming suit **10**, such as in the front panels **35** and not in the rear panel **40**, or in portions of both the front panel **35** and rear panel **40** in bra portion **20** and in particular the bra frame construction for added support and comfort. Fabric **100** and fabric **200** can also be used in the crotch **50** to prevent unwanted constriction movement during wear. Significantly, fabric **100** and fabric **200** are exemplary isotropic fabrics.

Referring to FIGS. **5a** and **5B**, fabric **100** and is knitted using a warp knitting machine, such as machine **300** having at least three guide bars **310**, as shown in FIG. **5b**. FIG. **5a** shows a knitting machine with four guide bars; however, three such bars can be used to knit fabric **100**. Fabric **100** is knitted using three bars of yarn that are intertwined together. Bars of yarn can be range from two to three yarns, depending upon the qualities of the yarn, so long as the elongations in the length direction, width direction and 45° diagonal direction, fall within the stated ranges in Table 1. Accordingly, each warp set of yarn of three yarns is threaded through one of the three guide bars **310** of the knitting bar to create the knitted construction of fabric **100**. Fabric **100** is a Raschel construction with one bar of nylon and two bars of spandex.

By using two different spandex yarns in the fabric, with different stitches on the two bars, the isotropic stretch and modulus are achieved.

The present disclosure has been described with particular reference to the preferred embodiments. It should be understood that the foregoing descriptions and examples are only illustrative of the present disclosure. Various alternatives and modifications thereof can be devised by those skilled in the art without departing from the spirit and scope of the present disclosure. Accordingly, the present disclosure is intended to embrace all such alternatives, modifications, and variations that fall within the scope of the appended claims.

We claim:

1. A single layer fabric that forms a garment, the fabric comprising:

a layer of material that lies in a single plane to form the garment, wherein the material comprises a first direction having a first modulus of elasticity, a second direction that is perpendicular to the first direction, wherein the second direction has a second modulus of elasticity and a third direction that is at an angle of 45 degrees to the first direction and the second direction, wherein the third direction has a third modulus of elasticity, and

wherein the first modulus of elasticity, the second modulus of elasticity and the third modulus of elasticity are within the same ranges of magnitude of modulus of elasticity and form the single layer fabric with equal modulus of elasticity in said first direction, said second direction and said third direction, and

wherein the single layer fabric further comprises at least three knitted yarns, wherein one of said three knitted yarns is knitted in said first direction, a second of said knitted yarns is knitted in said second direction, and a third of said three knitted yarns is knitted in said third direction,

wherein said at least three knitted yarns comprise two elastomeric yarns and one non-elastomeric yarn.

[2. The single layer fabric according to claim **1**, wherein each of said at least three knitted yarns is either an elastomeric yarn or a non-elastomeric yarn.]

[3. The single layer fabric according to claim **1**, wherein said at least three knitted yarns comprise two elastomeric yarns and one non-elastomeric yarn.]

[4. The single layer fabric according to claim **1**, wherein said at least three knitted yarns comprise one elastomeric yarn and two non-elastomeric yarns.]

5. The single layer fabric according to claim **[2]** *1*, wherein the elastomeric yarns comprise spandex.

6. The single layer fabric according to claim **[2]** *1*, wherein the non-elastomeric yarn comprises nylon, polyester, cotton, rayon or polypropylene or any combinations thereof.

7. The single layer fabric according to claim **[3]** *1*, wherein said at least three integrally knitted yarns comprise 8% to 60% elastomeric yarn by weight and 40% to 92% non-elastomeric yarn by weight.

[8. The single layer fabric according to claim **4**, wherein said at least three integrally knitted yarns comprise 50% to 85% non-elastomeric yarns by weight and 15% to 50% elastomeric yarns by weight.]

9. The single layer fabric according to claim **1**, wherein said layer of material comprises three bars of yarn and two of said three bars of yarn comprise elastomeric yarns that are integrally connected by a heating process.

10. The single layer fabric according to claim **9**, wherein one of the three bars lies in said first direction, a second of

the three bars lies in said second direction and a third of the three bars lies in said third direction.

11. The single layer fabric according to claim 1, wherein the ranges of magnitude of modulus are from 2.77 to 3.38 pounds of holding power at 30% stretch in the first direction, the second direction and the third direction, 5.85 to 7.15 pounds of holding power at 50% stretch in the first direction, the second direction and the third direction and 9.31 to 11.37 pounds of holding power at 70% stretch in the first direction, the second direction and the third direction.

12. The single layer fabric according to claim 1, wherein the stretch of the fabric in the first direction, the second direction and the third direction is in the range of from 112% to 137%.

13. The single layer fabric according to claim 1, wherein the ranges of magnitude of modulus are from 0.69 to 0.85 pounds of holding power at 30% stretch in the first direction, the second direction and the third direction, 1.33 to 1.64 pounds of holding power at 50% stretch in the first direction, the second direction and the third direction and 1.98 to 2.42 pounds of holding power at 70% stretch in the first direction, the second direction and the third direction.

14. The single layer fabric according to claim 1, wherein the stretch of the fabric in the first direction, the second direction and the third direction is in the range of from 193% to 237%.

15. The single layer fabric according to claim 1, wherein said first direction is a length direction, said second direction is a width direction being perpendicular to said length direction and said third direction is a diagonal direction at 45 degree angle to both said first direction and said second direction.

16. A garment comprising:

a single layer *circular knit* fabric covering a portion of a body of a wearer, wherein the single layer fabric comprises an isotropic material having a first direction having a first modulus of elasticity, a second direction that is perpendicular to the first direction, wherein the second direction has a second modulus of elasticity and a third direction that is at an angle of 45 degrees to the first direction and the second direction, wherein the third direction has a third modulus of elasticity,

wherein the first modulus of elasticity, the second modulus of elasticity and the third modulus of elasticity are within the same ranges of magnitudes of modulus of elasticity, and *wherein the first modulus of elasticity, the second modulus of elasticity and the third modulus of elasticity each have from 0.69 to 0.85 pounds of holding power at 30% stretch in the first direction, the second direction and the third direction, 1.33 to 1.64 pounds of holding power at 50% stretch in the first direction, the second direction and the third direction, and 1.98 to 2.42 pounds of holding power at 70% stretch in the first direction, the second direction and the third direction, and*

wherein the single layer fabric further comprises [three] two yarns that are either an elastomeric yarn or a non-elastomeric yarn.

[17. The garment according to claim 16, wherein said three yarns are knitted on a circular knitting machine.]

[18. The garment according to claim 16, wherein said three yarns are knitted in three bars.]

[19. The garment according to claim 16, wherein two of said three yarns are elastomeric yarns and one of said yarns is a non-elastomeric yarn.]

20. The garment according to claim 16, wherein [said integrally knitted] *the two yarns are integrally knitted yarns*

that comprise [two] at least one non-elastomeric [yarns] yarn and at least one elastomeric yarn.

21. The garment of claim 16, wherein [said] *the elastomeric [yarns comprise] yarn comprises* spandex.

22. The garment according to claim 16, wherein the non-elastomeric yarn [comprises] *is selected from the group consisting of* nylon, polyester, cotton, rayon or polypropylene [or], *and any combinations thereof.*

[23. The garment according to claim 19, wherein said knitted yarns comprise 8% to 60% elastomeric yarns by weight and 40% to 92% non-elastomeric yarns by weight.]

24. The garment according to claim 20, wherein the [integrally knitted] *two yarns are integrally knitted yarns that comprise 50% to 85% non-elastomeric yarn by weight and 15% to 50% elastomeric yarn by weight.*

[25. The garment according to claim 19, wherein said two elastomeric yarns are integrally connected by a heating process.]

[26. The garment according to claim 18, wherein one of the three bars lies in a length direction, a second of the three bars lies in a width direction perpendicular to the first bar and a third of the three bars lies in a direction at a 45° angle to the first bar and the second bar.]

[27. The garment according to claim 16, wherein the ranges of magnitude of modulus are from 2.77 to 3.38 pounds of holding power at 30% stretch in the first direction, the second direction and the third direction, 5.85 to 7.15 pounds of holding power at 50% stretch in the first direction, the second direction and the third direction and 9.31 to 11.37 pounds of holding power at 70% stretch in the first direction, the second direction and the third direction.]

[28. The garment according to claim 16, wherein the stretch of the single layer fabric in the first direction, the second direction and the third direction is in the range of from 112% to 137%.]

[29. The garment according to claim 16, wherein the ranges of magnitude of modulus are from 0.69 to 0.85 pounds of holding power at 30% stretch in the first direction, the second direction and the third direction, 1.33 to 1.64 pounds of holding power at 50% stretch in the first direction, the second direction and the third direction and 1.98 to 2.42 pounds of holding power at 70% stretch in the first direction, the second direction and the third direction.]

30. The garment according to claim 16, wherein the stretch of the single layer fabric in the first direction, the second direction and the third direction is in the range of from 193% to 237%.

31. The garment according to claim 16, wherein the single layer fabric comprises at least one of a torso portion to be worn on the torso of the body; a bra portion to be worn over the bust area of the body; or a panty portion including a crotch portion to be worn over the buttocks of the body or any combinations thereof.

32. The garment according to claim 31, wherein the torso portion further comprises a front panel and a back panel.

33. The garment according to claim 31, wherein the bra portion is connected to the torso portion and the torso portion is connected to the panty portion.

34. The garment according to claim [19] 20, wherein the *at least one non-elastomeric yarn comprises a flat filament nylon yarn.*

35. The garment according to claim 20, wherein the *at least one non-elastomeric [yarns comprise] yarn comprises a textured filament nylon.*

36. *A garment comprising: a single layer circular knit fabric covering a portion of a body of a wearer, wherein the single layer fabric*

comprises an isotropic material having a first direction having a first modulus of elasticity and a second direction that is perpendicular to the first direction, wherein the second direction has a second modulus of elasticity, and a third direction that is at an angle of 45 5 degrees to the first direction and the second direction, wherein the third direction has a third modulus of elasticity,

wherein the first modulus of elasticity, the second modulus of elasticity and the third modulus of elasticity are 10 within the same ranges of magnitudes of modulus of elasticity, and

wherein the single layer fabric comprises two yarns that comprise at least one elastomeric yarn and at least one 15 non-elastomeric yarn, and

wherein the stretch of the single layer fabric in the first direction, the second direction and the third direction is in the range of from 193% to 237%.

* * * * *