



US00RE47375E

(19) **United States**
(12) **Reissued Patent**
Shields et al.

(10) **Patent Number:** **US RE47,375 E**
(45) **Date of Reissued Patent:** **May 7, 2019**

(54) **TISSUE SEALER WITH NON-CONDUCTIVE VARIABLE STOP MEMBERS AND METHOD OF SEALING TISSUE**

(58) **Field of Classification Search**
CPC A61B 18/1445; A61B 18/1442; A61B 17/22031; A61B 17/18
(Continued)

(71) Applicant: **Covidien AG**, Neuhausen am Rheinfall (CH)

(56) **References Cited**

U.S. PATENT DOCUMENTS

(72) Inventors: **Chelsea Shields**, San Francisco, CA (US); **Edward C Meagher**, Greenlawn, NY (US)

1,586,645 A 6/1926 Bierman
1,813,902 A 7/1931 Bovie
(Continued)

FOREIGN PATENT DOCUMENTS

(73) Assignee: **Covidien AG**, Neuhausen am Rheinfall (CH)

CA 2104423 2/1994
CA 2104423 A1 2/1994
(Continued)

(21) Appl. No.: **14/813,325**

OTHER PUBLICATIONS

(22) Filed: **Jul. 30, 2015**

US 6,663,629, 12/2003, Buysse et al. (withdrawn)
(Continued)

Related U.S. Patent Documents

Reissue of:

Primary Examiner — Beverly M Flanagan

(64) Patent No.: **8,496,656**
Issued: **Jul. 30, 2013**
Appl. No.: **12/355,622**
Filed: **Jan. 16, 2009**

(57) **ABSTRACT**

U.S. Applications:

(63) Continuation of application No. 10/846,262, filed on May 14, 2004, now Pat. No. 7,491,201.

[A bipolar forceps for sealing tissue includes an elongated shaft having opposing jaw members at a distal end thereof, each of the jaw members including an electrically conductive sealing surface. The jaw members are movable relative to one another from a first position wherein the jaw members are disposed in spaced relation relative to one another to a second position wherein the jaw members cooperate to grasp tissue therebetween. The bipolar forceps is connected to a source of electrical energy such that the jaw members are capable of conducting bipolar energy through tissue grasped therebetween to effect a seal. The distance between the electrically conductive sealing surfaces when tissue is held therebetween is adjusted based upon a sensed pre-surgical condition during activation.] *A bipolar forceps for sealing tissue includes an elongated shaft having opposing jaw members at a distal end thereof, each of the jaw members including an electrically conductive sealing surface. The jaw members are movable relative to one another from a first*

(Continued)

(51) **Int. Cl.**

A61B 18/14 (2006.01)

A61B 17/22 (2006.01)

A61B 17/28 (2006.01)

(52) **U.S. Cl.**

CPC **A61B 17/22031** (2013.01); **A61B 17/28** (2013.01)

(Continued)

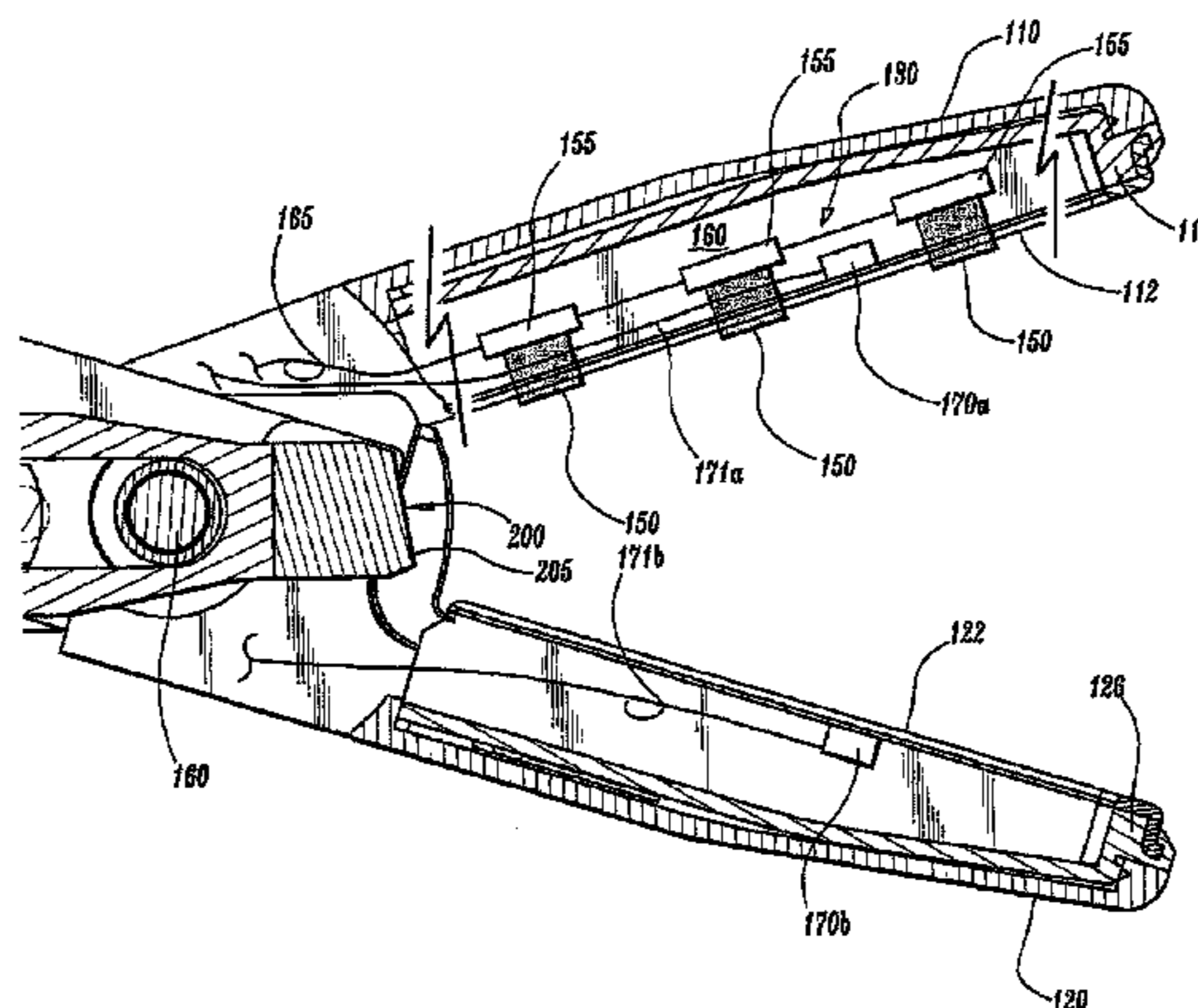

position wherein the jaw members are disposed in spaced relation relative to one another to a second position wherein the jaw members cooperate to grasp tissue therebetween. The bipolar forceps is connected to a source of electrical energy such that the jaw members are capable of conducting bipolar energy through tissue grasped therebetween to affect a seal. The distance between the electrically conductive sealing surfaces when tissue is held therebetween is adjusted based upon a sensed pre-surgical condition during activation.

10 Claims, 5 Drawing Sheets

Related U.S. Application Data

- (60) Provisional application No. 60/470,632, filed on May 15, 2003.
- (58) **Field of Classification Search**
USPC 606/45-52; 294/99.2
See application file for complete search history.

(56) **References Cited**

U.S. PATENT DOCUMENTS

1,822,330 A	9/1931	Ainslie
1,852,542 A	4/1932	Sovatkin
2,002,594 A	5/1935	Wappler et al.
2,011,169 A	8/1935	Wappler
2,031,682 A	2/1936	Wappler et al.
2,054,149 A	9/1936	Wappler
2,176,479 A	10/1939	Willis
2,305,156 A	4/1941	Grubel
2,279,753 A	4/1942	Knopp
2,327,353 A	8/1943	Karle
2,632,661 A	8/1948	Cristofv
2,668,538 A	2/1954	Baker
2,796,065 A	6/1957	Kapp
3,073,311 A	1/1963	Tibbs et al.
3,459,187 A	3/1967	Pallotta
3,372,288 A	3/1968	Wigington
3,643,663 A	2/1972	Sutter
3,648,001 A	3/1972	Anderson et al.
3,651,811 A	3/1972	Hildebrandt et al.
3,678,229 A	7/1972	Osika
3,720,896 A	3/1973	Beierlein
3,763,726 A	10/1973	Hildebrand
3,779,918 A	12/1973	Ikeda et al.
3,801,766 A	4/1974	Morrison, Jr.
3,862,630 A	1/1975	Balamuth
3,863,339 A	2/1975	Reaney et al.
3,866,610 A	2/1975	Kletschka
3,911,766 A	10/1975	Fridolph et al.
3,920,021 A	11/1975	Hiltebrandt
3,921,641 A	11/1975	Hulka
3,938,527 A	2/1976	Rioux et al.
3,952,749 A	4/1976	Fridolph et al.
3,970,088 A	7/1976	Morrison
3,987,795 A	10/1976	Morrison
4,005,714 A	2/1977	Hiltebrandt
4,016,881 A	4/1977	Rioux et al.
4,041,952 A	8/1977	Morrison, Jr. et al.
4,043,342 A	8/1977	Morrison, Jr.
4,074,718 A	2/1978	Morrison, Jr.
4,076,028 A	2/1978	Simmons
4,080,820 A	3/1978	Allen
4,088,134 A	5/1978	Mazzariello
4,112,950 A	9/1978	Pike
4,127,222 A	11/1978	Adams
4,128,099 A	12/1978	Bauer
4,165,746 A	8/1979	Burgin
4,187,420 A	2/1980	Piber
4,233,734 A	11/1980	Bies

4,236,470 A	12/1980	Stenson
4,300,564 A	11/1981	Furihata
4,311,145 A	1/1982	Esty et al.
D263,020 S	2/1982	Rau, III
4,370,980 A	2/1983	Lottick
4,375,218 A *	3/1983	DiGeronimo 606/52
4,416,276 A	11/1983	Newton et al.
4,418,692 A	12/1983	Guay
4,443,935 A	4/1984	Zamba et al.
4,452,246 A	6/1984	Bader et al.
4,470,786 A	9/1984	Sano et al.
4,492,231 A	1/1985	Auth
4,493,320 A	1/1985	Treat
4,503,855 A	3/1985	Maslanka
4,506,669 A	3/1985	Blake, III
4,509,518 A	4/1985	McGarry et al.
4,552,143 A	11/1985	Lottick
4,574,804 A	3/1986	Kurwa
4,597,379 A	7/1986	Kihn et al.
4,600,007 A	7/1986	Lahodny et al.
4,624,254 A	11/1986	McGarry et al.
4,655,215 A	4/1987	Pike
4,655,216 A	4/1987	Tischer
4,657,016 A	4/1987	Garito et al.
4,662,372 A	5/1987	Sharkany et al.
4,671,274 A	6/1987	Sorochenko
4,685,459 A	8/1987	Xoch et al.
371,664 A	10/1987	Brannan et al.
4,733,662 A	3/1988	DeSatnick et al.
D295,893 S	5/1988	Sharkany et al.
D295,894 S	5/1988	Sharkany et al.
4,754,892 A	7/1988	Retief
4,763,669 A	8/1988	Jaeger
4,827,929 A	5/1989	Hodge
4,829,313 A	5/1989	Taggart
4,846,171 A	7/1989	Kauphusman et al.
4,887,612 A	12/1989	Esser et al.
4,938,761 A	7/1990	Ensslin
4,947,009 A	8/1990	Osika et al.
4,985,030 A	1/1991	Melzer et al.
5,007,908 A	4/1991	Rydell
5,026,370 A	6/1991	Lottick
5,026,371 A	6/1991	Rydell et al.
5,035,695 A	7/1991	Weber, Jr. et al.
5,037,433 A	8/1991	Wilk et al.
5,042,707 A	8/1991	Taheri
5,047,046 A	9/1991	Bodoia
5,078,716 A	1/1992	Doll
5,084,057 A	1/1992	Green et al.
5,085,659 A	2/1992	Rydell
5,099,840 A	3/1992	Goble et al.
5,100,430 A	3/1992	Avellanet et al.
5,108,392 A	4/1992	Spingler
5,112,343 A	5/1992	Thornton
5,116,332 A	5/1992	Lottick
5,147,357 A	9/1992	Rose et al.
5,151,102 A	9/1992	Kamiyama et al.
5,151,978 A	9/1992	Bronikowski et al.
5,176,695 A	1/1993	Dulebohn
5,190,541 A	3/1993	Abele et al.
5,196,009 A	3/1993	Kirwan, Jr.
5,197,964 A	3/1993	Parins
5,209,747 A	5/1993	Knoepfler
5,211,655 A	5/1993	Hasson
5,215,101 A	6/1993	Jacobs et al.
5,217,457 A	6/1993	Delahuerga et al.
5,217,458 A	6/1993	Parins
5,217,460 A	6/1993	Knoepfler
5,219,354 A	6/1993	Choudhury et al.
5,244,462 A	9/1993	Delahuerga et al.
5,250,047 A	10/1993	Rydell
5,250,063 A	10/1993	Abidin et al.
5,258,001 A	11/1993	Corman
5,258,006 A	11/1993	Rydell et al.
5,261,918 A	11/1993	Phillips et al.
5,275,615 A	1/1994	Rose
5,277,201 A	1/1994	Stern
5,282,799 A	2/1994	Rydell
5,282,800 A	2/1994	Foshee et al.

(56)

References Cited

U.S. PATENT DOCUMENTS

5,282,826 A	2/1994	Quadri	5,480,406 A	1/1996	Nolan et al.
5,290,286 A	3/1994	Parins	5,480,409 A	1/1996	Riza
5,300,082 A	4/1994	Sharpe et al.	5,484,436 A	1/1996	Eggers et al.
5,304,203 A	4/1994	El-Mallawany et al.	5,496,312 A	3/1996	Klicek
5,308,353 A	5/1994	Beurrier	5,496,317 A	3/1996	Goble et al.
5,308,357 A	5/1994	Lichtman	5,496,347 A	3/1996	Hashiguchi et al.
5,313,027 A	5/1994	Inoue et al.	5,499,997 A	3/1996	Sharpe et al.
5,314,445 A	5/1994	Degwitz et al.	5,509,922 A	4/1996	Aranyi et al.
5,318,589 A	6/1994	Lichtman	5,512,721 A	4/1996	Young et al.
5,324,289 A	6/1994	Eggers	5,514,134 A	5/1996	Rydell et al.
D348,930 S	7/1994	Olson	5,527,313 A	6/1996	Scott et al.
5,326,806 A	7/1994	Yokoshima et al.	5,528,833 A	6/1996	Sakuma
5,330,471 A	7/1994	Eggers	5,529,067 A	6/1996	Larsen et al.
5,330,502 A	7/1994	Hassler et al.	5,531,744 A	7/1996	Nardella et al.
5,334,183 A	8/1994	Wuchinich	5,536,251 A	7/1996	Evard et al.
5,334,215 A	8/1994	Chen	5,540,684 A	7/1996	Hassler, Jr.
5,336,220 A	8/1994	Ryan et al.	5,540,685 A	7/1996	Parins et al.
5,336,221 A	8/1994	Anderson	5,540,706 A	7/1996	Aust et al.
5,342,359 A	8/1994	Rydell	5,540,715 A	7/1996	Katsaros et al.
5,342,381 A	8/1994	Tidemand	5,542,945 A	8/1996	Fritzsch
5,342,393 A	8/1994	Stack	5,558,671 A	9/1996	Yates
5,344,424 A	9/1994	Roberts et al.	5,558,672 A	9/1996	Edwards et al.
5,350,391 A	9/1994	Iacovelli	5,562,619 A	10/1996	Mirarchi et al.
5,352,222 A	10/1994	Rydell	5,562,699 A	10/1996	Heimberger et al.
5,354,271 A	10/1994	Voda	5,562,720 A	10/1996	Stern et al.
5,356,408 A	10/1994	Rydell	5,564,615 A	10/1996	Bishop et al.
5,366,477 A	11/1994	LeMarie, III et al.	5,569,241 A	10/1996	Edwards
5,368,600 A	11/1994	Failla et al.	5,569,243 A	10/1996	Kortenbach et al.
5,374,277 A	12/1994	Hassler	5,571,100 A	11/1996	Goble et al.
5,376,089 A	12/1994	Smith	5,573,424 A	11/1996	Poppe
5,383,875 A	1/1995	Bays et al.	5,573,534 A	11/1996	Stone
5,383,897 A	1/1995	Wholey	5,573,535 A	11/1996	Viklund
5,389,098 A	2/1995	Tsuruta et al.	5,575,799 A	11/1996	Bolanos et al.
5,389,103 A	2/1995	Melzer et al.	5,575,805 A	11/1996	Li
5,389,104 A	2/1995	Hahnen et al.	5,578,052 A	11/1996	Koros et al.
5,391,166 A	2/1995	Eggers	5,579,781 A	12/1996	Cooke
5,391,183 A	2/1995	Janzen et al.	5,582,611 A	12/1996	Tsuruta et al.
5,396,900 A	3/1995	Slater et al.	5,582,617 A	12/1996	Klieman et al.
5,403,312 A	4/1995	Yates et al.	5,585,896 A	12/1996	Yamazaki et al.
5,403,342 A	4/1995	Tovey et al.	5,590,570 A	1/1997	LeMaire, III et al.
5,405,344 A	4/1995	Williamson et al.	5,591,181 A	1/1997	Stone et al.
5,409,763 A	4/1995	Serizawa et al.	5,597,107 A	1/1997	Knodel et al.
5,411,519 A	5/1995	Tovey et al.	5,601,224 A	2/1997	Bishop et al.
5,411,520 A	5/1995	Nash et al.	5,601,601 A	2/1997	Tal et al.
5,413,571 A	5/1995	Katsaros et al.	5,601,641 A	2/1997	Stephens
5,415,656 A	5/1995	Tihon et al.	5,603,711 A	2/1997	Parins et al.
5,415,657 A	5/1995	Taymor-Luria	5,603,723 A	2/1997	Aranyi et al.
5,422,567 A	6/1995	Matsunaga	5,611,798 A	3/1997	Eggers
5,423,810 A	6/1995	Goble et al.	5,611,808 A	3/1997	Hossain et al.
5,425,690 A	6/1995	Chang	5,611,813 A	3/1997	Lichtman
5,425,739 A	6/1995	Jessen	5,620,415 A	4/1997	Lucey et al.
5,429,616 A	7/1995	Schaffer	5,620,453 A	4/1997	Nallakrishnan
5,431,672 A	7/1995	Cote et al.	5,620,459 A	4/1997	Lichtman
5,431,674 A	7/1995	Basile et al.	5,624,452 A	4/1997	Yates
5,437,292 A	8/1995	Kipshidze et al.	5,626,578 A	5/1997	Tihon
5,438,302 A	8/1995	Goble	5,626,609 A	5/1997	Zvenyatsky et al.
5,439,478 A	8/1995	Palmer	5,630,833 A	5/1997	Katsaros et al.
5,441,517 A	8/1995	Kensley et al.	5,637,110 A	6/1997	Pennybacker et al.
5,443,463 A	8/1995	Stern et al.	5,638,003 A	6/1997	Hall
5,443,464 A	8/1995	Russell et al.	5,643,294 A	7/1997	Tovey et al.
5,443,480 A	8/1995	Jacobs et al.	5,647,869 A	7/1997	Goble et al.
5,445,638 A	8/1995	Rydell et al.	5,647,871 A	7/1997	Levine et al.
5,445,658 A	8/1995	Durrfeld et al.	5,649,959 A	7/1997	Hannam et al.
5,449,480 A	9/1995	Kuriya et al.	5,655,650 A	8/1997	Naitou
5,451,224 A	9/1995	Goble et al.	5,658,281 A	8/1997	Heard
5,454,823 A	10/1995	Richardson et al.	D384,413 S	9/1997	Zlock et al.
5,454,827 A	10/1995	Aust et al.	5,662,667 A	9/1997	Knodel
5,456,684 A	10/1995	Schmidt et al.	5,665,100 A	9/1997	Yoon
5,458,598 A	10/1995	Feinberg et al.	5,667,526 A	9/1997	Levin
5,460,629 A	10/1995	Shlain et al.	5,674,220 A	10/1997	Fox et al.
5,461,765 A	10/1995	Linden et al.	5,674,229 A	10/1997	Tovey et al.
5,462,546 A	10/1995	Rydell	5,681,282 A	10/1997	Eggers et al.
5,472,442 A	12/1995	Klicek	5,688,270 A	11/1997	Yates et al.
5,472,443 A	12/1995	Cordis et al.	5,690,652 A	11/1997	Wurster et al.
5,478,351 A	12/1995	Meade et al.	5,690,653 A	11/1997	Richardson et al.
			5,693,051 A	12/1997	Schulze et al. .. A61B 17/07207
					606/41
			5,693,920 A	12/1997	Maeda
			5,695,522 A	12/1997	LeMaire, III et al.

(56)

References Cited

U.S. PATENT DOCUMENTS

5,700,261 A	12/1997	Brinkerhoff	5,921,916 A	7/1999	Aeikens et al.
5,700,270 A	12/1997	Peyser et al.	5,921,984 A	7/1999	Sutcu et al.
5,702,390 A	12/1997	Austin et al.	5,925,043 A	7/1999	Kumar et al.
5,707,369 A	1/1998	Vaitekunas et al.	5,928,136 A	7/1999	Barry
5,709,680 A	1/1998	Yates et al.	5,935,126 A	8/1999	Riza
5,716,366 A	2/1998	Yates	5,941,869 A	8/1999	Patterson et al.
5,720,744 A	2/1998	Eggleston et al.	5,944,718 A	8/1999	Austin et al.
5,722,421 A	3/1998	Francese et al.	5,951,546 A	9/1999	Lorentzen
5,725,536 A	3/1998	Oberlin et al.	5,951,549 A	9/1999	Richardson et al.
5,727,428 A	3/1998	LeMaire, III et al.	5,954,720 A	9/1999	Wilson et al.
5,735,848 A	4/1998	Yates et al.	5,954,731 A	9/1999	Yoon
5,743,906 A	4/1998	Parins et al.	5,954,733 A	9/1999	Yoon
5,752,973 A	5/1998	Kieturakis	5,957,923 A	9/1999	Hahnen et al.
5,755,717 A	5/1998	Yates et al.	5,957,937 A	9/1999	Yoon
5,759,188 A	6/1998	Yoon	5,960,544 A	10/1999	Beyers
5,766,130 A	6/1998	Selmonosky	5,961,514 A	10/1999	Long et al.
5,766,166 A	6/1998	Hooven	5,964,758 A	10/1999	Dresden
5,766,170 A	6/1998	Eggers	5,976,132 A	11/1999	Morris
5,766,196 A	6/1998	Griffiths	5,984,932 A	11/1999	Yoon
5,769,849 A	6/1998	Eggers	5,984,938 A	11/1999	Yoon
5,772,655 A	6/1998	Bauer et al.	5,984,939 A	11/1999	Yoon
5,772,670 A	6/1998	Brosa	5,989,277 A	11/1999	LeMaire, III et al.
5,776,128 A	7/1998	Eggers	5,993,466 A	11/1999	Yoon
5,776,130 A	7/1998	Buysse et al.	5,993,467 A	11/1999	Yoon
5,779,646 A	7/1998	Koblish et al.	5,997,565 A	12/1999	Inoue
5,779,701 A	7/1998	McBrayer et al.	6,004,332 A	12/1999	Yoon et al.
H1745 H	8/1998	Paraschac	6,004,335 A	12/1999	Vaitekunas et al.
5,792,137 A	8/1998	Carr et al.	6,010,516 A	1/2000	Hulka et al.
5,792,165 A	8/1998	Klieman et al.	6,017,358 A	1/2000	Yoon et al.
5,792,177 A	8/1998	Kaseda	6,021,693 A	2/2000	Feng-Sing
5,797,537 A	8/1998	Oberlin et al.	6,024,741 A	2/2000	Williamson et al.
5,797,927 A	8/1998	Yoon	6,024,743 A	2/2000	Edwards
5,797,938 A	8/1998	Paraschac et al.	6,024,744 A	2/2000	Kese et al.
5,797,941 A	8/1998	Schulze et al.	6,027,522 A	2/2000	Palmer
5,797,958 A	8/1998	Yoon	6,030,384 A	2/2000	Nezhat
5,800,449 A	9/1998	Wales	6,033,399 A	3/2000	Gines
5,807,393 A	9/1998	Williamson, IV et al.	6,039,733 A	3/2000	Buysse et al.
5,810,764 A	9/1998	Eggers et al.	6,041,679 A	3/2000	Slater et al.
5,810,805 A	9/1998	Sutcu et al.	6,050,996 A *	4/2000	Schmaltz et al. 606/51
5,810,808 A	9/1998	Eggers	6,053,914 A	4/2000	Eggers et al.
5,810,811 A	9/1998	Yates et al.	6,053,933 A	4/2000	Balazs et al.
5,810,877 A	9/1998	Roth et al.	D424,694 S	5/2000	Tetzlaff et al.
5,814,043 A	9/1998	Shapeton	D425,201 S	5/2000	Tetzlaff et al.
5,814,054 A	9/1998	Kortenbach et al.	6,059,782 A	5/2000	Novak et al.
5,817,083 A	10/1998	Shemesh et al.	6,066,139 A	5/2000	Ryan et al.
5,817,093 A	10/1998	Williamson, IV et al.	6,074,386 A	6/2000	Goble et al.
5,817,119 A	10/1998	Klieman et al.	6,077,287 A	6/2000	Taylor et al.
5,820,630 A	10/1998	Lind	6,080,180 A	6/2000	Yoon et al.
5,824,978 A	10/1998	Karasik et al.	RE36,795 E	7/2000	Rydell
5,827,271 A	10/1998	Buysse et al.	6,083,223 A	7/2000	Baker
5,827,279 A	10/1998	Hughett et al.	6,086,586 A	7/2000	Hooven
5,827,281 A	10/1998	Levin	6,086,601 A	7/2000	Yoon
5,827,323 A	10/1998	Klieman et al.	6,090,107 A	7/2000	Borgmeier et al.
5,827,548 A	10/1998	Lavallee et al.	6,096,031 A	8/2000	Mitchell et al.
5,833,690 A	11/1998	Yates et al.	6,096,037 A	8/2000	Mulier et al.
5,843,080 A	12/1998	Fleenor et al.	6,099,550 A	8/2000	Yoon
5,849,022 A	12/1998	Sakashita et al.	6,102,909 A	8/2000	Chen et al.
5,853,412 A	12/1998	Mayenberger	6,106,542 A	8/2000	Toybin et al.
5,859,527 A	1/1999	Cook	6,110,171 A	8/2000	Rydell
5,860,976 A	1/1999	Billings et al.	6,113,596 A	9/2000	Hooven et al.
5,876,401 A	3/1999	Schulze et al.	6,113,598 A	9/2000	Baker
5,876,412 A	3/1999	Piraka	6,117,158 A	9/2000	Measamer et al.
5,882,567 A	3/1999	Cavallaro et al.	6,122,549 A	9/2000	Sharkey et al.
5,891,141 A	4/1999	Rydell	6,123,701 A	9/2000	Nezhat
5,891,142 A	4/1999	Eggers et al.	H1904 H	10/2000	Yates et al.
5,893,863 A	4/1999	Yoon	6,126,658 A	10/2000	Baker
5,893,875 A	4/1999	O'Connor et al.	6,126,665 A	10/2000	Yoon
5,893,877 A	4/1999	Gampp, Jr. et al.	6,139,563 A	10/2000	Cosgrove, III et al.
5,897,563 A	4/1999	Yoon et al.	6,143,005 A	11/2000	Yoon et al.
5,902,301 A	5/1999	Olig	6,152,923 A	11/2000	Ryan
5,906,630 A	5/1999	Anderhub et al.	6,162,220 A	12/2000	Nezhat
5,908,420 A	6/1999	Parins et al.	6,171,316 B1	1/2001	Kovac et al.
5,908,432 A	6/1999	Pan	6,174,309 B1	1/2001	Wrublewski et al.
5,911,719 A	6/1999	Eggers	6,178,628 B1	1/2001	Clemens et al.
5,913,874 A	6/1999	Berns et al.	6,179,834 B1	1/2001	Buysse et al.
			6,179,837 B1	1/2001	Hooven
			6,183,467 B1	2/2001	Shapeton et al.
			6,187,003 B1	2/2001	Buysse et al.
			6,190,386 B1	2/2001	Rydell

(56)

References Cited

U.S. PATENT DOCUMENTS

6,190,400 B1	2/2001	VanDeMoer et al.	6,514,252 B2	2/2003	Nezhat et al.
6,193,718 B1	2/2001	Kortenbach et al.	6,517,539 B1	2/2003	Smith et al.
6,206,876 B1	3/2001	Levine et al.	6,527,771 B1	3/2003	Weadock et al.
6,206,877 B1	3/2001	Kese et al.	6,533,784 B2	3/2003	Truckai et al.
6,206,893 B1	3/2001	Klein et al.	6,544,264 B2	4/2003	Levine et al.
6,214,028 B1	4/2001	Yoon et al.	6,545,239 B2	4/2003	Pedersen et al.
6,217,602 B1	4/2001	Redmon	728,883 A1	5/2003	Downes
6,217,615 B1	4/2001	Sioshansi et al.	6,558,385 B1	5/2003	McClurken et al.
6,221,039 B1	4/2001	Durgin et al.	6,562,037 B2*	5/2003	Paton et al. 606/51
6,223,100 B1	4/2001	Green	6,569,105 B1	5/2003	Kortenbach et al.
6,224,593 B1	5/2001	Ryan et al.	6,569,162 B2	5/2003	He
6,224,614 B1	5/2001	Yoon	6,582,450 B2	6/2003	Ouchi
6,228,080 B1	5/2001	Gines	6,585,735 B1	7/2003	Frazier et al.
6,228,083 B1	5/2001	Lands et al.	6,602,252 B2	8/2003	Mollenauer
6,248,124 B1	6/2001	Pedros et al.	6,605,790 B2	8/2003	Yoshida
6,248,944 B1	6/2001	Ito	6,616,658 B2	9/2003	Ineson
6,261,307 B1	7/2001	Yoon et al.	6,616,661 B2	9/2003	Wellman et al.
6,267,761 B1	7/2001	Ryan	6,620,161 B2	9/2003	Schulze et al.
6,270,497 B1	8/2001	Sekino et al.	6,620,184 B2	9/2003	De Laforcade et al.
6,270,508 B1	8/2001	Klieman et al.	6,626,901 B1	9/2003	Treat et al.
6,273,887 B1	8/2001	Yamauchi et al.	6,638,287 B2	10/2003	Danitz et al.
6,277,117 B1	8/2001	Tetzlaff et al.	6,641,595 B1	11/2003	Moran et al.
6,280,458 B1	8/2001	Boche et al.	6,652,514 B2	11/2003	Ellman et al.
6,283,961 B1	9/2001	Underwood et al.	6,652,521 B2	11/2003	Schulze
D449,886 S	10/2001	Tetzlaff et al.	6,656,175 B2	12/2003	Francischelli et al.
6,298,550 B1	10/2001	Kirwan	6,656,177 B2	12/2003	Truckai et al.
6,302,424 B1	10/2001	Gisinger et al.	6,660,072 B2	12/2003	Chatterjee
6,319,262 B1	11/2001	Bates et al.	6,663,639 B1	12/2003	Laufer et al.
6,319,451 B1	11/2001	Brune	6,663,641 B1	12/2003	Kovac et al.
6,322,561 B1	11/2001	Eggers et al.	6,666,854 B1	12/2003	Lange
6,322,580 B1	11/2001	Kanner	6,669,696 B2	12/2003	Bacher et al.
6,325,795 B1	12/2001	Lindemann et al.	6,673,092 B1	1/2004	Bacher
6,334,860 B1	1/2002	Dorn	6,676,660 B2	1/2004	Wampler et al.
6,334,861 B1	1/2002	Chandler et al.	6,676,676 B2	1/2004	Danitz et al.
6,345,532 B1	2/2002	Coudray et al.	6,679,882 B1	1/2004	Kornerup
6,350,264 B1	2/2002	Hooven	6,682,527 B2	1/2004	Strul
6,352,536 B1	3/2002	Buysse et al.	6,682,528 B2	1/2004	Frazier et al.
6,358,249 B1	3/2002	Chen et al.	6,685,724 B1	2/2004	Haluck
6,358,259 B1	3/2002	Swain et al.	6,689,131 B2	2/2004	McClurken
6,358,268 B1	3/2002	Hunt et al.	6,692,445 B2	2/2004	Roberts et al.
6,364,879 B1	4/2002	Chen et al.	6,693,246 B1	2/2004	Rudolph et al.
D457,958 S	5/2002	Dycus et al.	6,695,840 B2	2/2004	Schulze
D457,959 S	5/2002	Tetzlaff et al.	6,702,810 B2	3/2004	McClurken et al.
6,387,094 B1	5/2002	Eitenmuller	6,723,092 B2	4/2004	Brown et al.
6,391,035 B1	5/2002	Appleby et al.	6,726,068 B2	4/2004	Miller
702,472 A1	6/2002	Pignolet	6,726,686 B2	4/2004	Buysse et al.
6,398,779 B1	6/2002	Buysse et al.	6,726,694 B2	4/2004	Blatter et al.
6,402,747 B1	6/2002	Lindemann et al.	6,733,498 B2	5/2004	Paton et al.
6,409,728 B1	6/2002	Ehr et al.	6,736,813 B2	5/2004	Yamauchi et al.
H2037 H	7/2002	Yates et al.	6,743,229 B2	6/2004	Buysse et al.
6,419,675 B1	7/2002	Gallo, Sr.	6,743,230 B2	6/2004	Lutze et al.
6,425,896 B1	7/2002	Baltschun et al.	6,743,239 B1	6/2004	Kuehn et al.
6,432,112 B2	8/2002	Brock et al.	6,743,240 B2	6/2004	Smith et al.
6,440,144 B1	8/2002	Bacher	6,755,843 B2	6/2004	Chung et al.
6,443,952 B1	9/2002	Mulier et al.	6,756,553 B1	6/2004	Yamaguchi et al.
6,443,970 B1	9/2002	Schulze et al.	6,757,977 B2	7/2004	Dambal et al.
6,451,018 B1	9/2002	Lands et al.	D493,888 S	8/2004	Reschke
6,458,125 B1	10/2002	Cosmescu	6,770,072 B1	8/2004	Truckai et al.
6,458,128 B1	10/2002	Schulze	6,773,409 B2	8/2004	Truckai et al.
6,458,130 B1	10/2002	Frazier et al.	6,773,432 B1	8/2004	Clayman et al.
6,461,352 B2	10/2002	Morgan et al.	6,773,434 B2	8/2004	Ciarrocca
6,461,368 B2	10/2002	Fogarty et al.	6,773,441 B1	8/2004	Laufer et al.
6,464,701 B1	10/2002	Hooven et al.	6,775,575 B2	8/2004	Bommannan et al.
6,464,702 B2	10/2002	Schulze et al.	6,776,780 B2	8/2004	Mulier et al.
6,464,704 B2	10/2002	Schmaltz et al.	6,786,905 B2	9/2004	Swanson et al.
6,485,489 B2	11/2002	Teirstein et al.	6,790,217 B2	9/2004	Schulze et al.
6,494,888 B1	12/2002	Laufer et al.	6,796,981 B2	9/2004	Wham et al.
6,500,176 B1	12/2002	Truckai et al.	D496,997 S	10/2004	Dycus et al.
6,503,248 B1	1/2003	Levine	6,800,825 B1	10/2004	Sasaki et al.
6,506,189 B1	1/2003	Rittman et al.	6,802,843 B2	10/2004	Truckai et al.
6,506,196 B1	1/2003	Laufer	6,808,525 B2	10/2004	Latterell et al.
6,508,815 B1	1/2003	Strul et al.	D499,181 S	11/2004	Dycus et al.
6,511,480 B1	1/2003	Tetzlaff et al.	6,818,000 B2	11/2004	Muller et al.
6,514,215 B1	2/2003	Ouchi	6,821,285 B2	11/2004	Laufer et al.
6,514,251 B1	2/2003	Ni et al.	6,835,200 B2	12/2004	Laufer et al.
			6,857,357 B2	2/2005	Fujii
			6,860,880 B2	3/2005	Treat et al.
			6,887,240 B1	5/2005	Lands et al.
			6,889,116 B2	5/2005	Jinno

(56)

References Cited

U.S. PATENT DOCUMENTS

6,914,201 B2	7/2005	Van Vooren et al.	7,223,265 B2	5/2007	Keppel
6,926,716 B2	8/2005	Baker et al.	7,232,440 B2	6/2007	Dumbauld et al.
6,929,644 B2	8/2005	Truckai et al.	7,241,288 B2	7/2007	Braun
6,932,810 B2	8/2005	Ryan	7,241,296 B2	7/2007	Buysse et al.
6,932,816 B2	8/2005	Phan	7,244,257 B2	7/2007	Podjahsky et al.
6,934,134 B2	8/2005	Mori et al.	7,246,734 B2	7/2007	Shelto, IV
6,936,061 B2	8/2005	Sasaki	7,248,944 B2	7/2007	Green
D509,297 S	9/2005	Wells	7,252,667 B2	8/2007	Moses et al.
6,942,662 B2	9/2005	Goble et al.	7,255,697 B2	8/2007	Dycus et al.
6,943,311 B2	9/2005	Miyako	7,267,677 B2	9/2007	Johnson et al.
6,953,430 B2	10/2005	Kodooka	7,270,660 B2	9/2007	Ryan
6,953,461 B2	10/2005	McClurken et al.	7,270,664 B2	9/2007	Johnson et al.
6,958,070 B2	10/2005	Witt et al.	7,276,068 B2	10/2007	Johnson et al.
6,960,210 B2	11/2005	Lands et al.	7,300,435 B2	11/2007	Wham et al.
6,964,662 B2	11/2005	Kidooka	7,303,557 B2	12/2007	Wham et al.
6,966,907 B2	11/2005	Goble	7,311,709 B2	12/2007	Truckai et al.
6,972,017 B2	12/2005	Smith et al.	7,314,471 B2	1/2008	Holman
6,977,495 B2	12/2005	Donofrio	7,318,823 B2	1/2008	Sharps et al.
6,979,786 B2	12/2005	Aukland et al.	7,329,256 B2	2/2008	Johnson et al.
6,981,628 B2	1/2006	Wales	7,329,257 B2	2/2008	Kanehira et al.
6,987,244 B2	1/2006	Bauer	D564,662 S	3/2008	Moses et al.
6,994,707 B2	2/2006	Ellman et al.	7,338,526 B2	3/2008	Steinberg
6,994,709 B2	2/2006	Iida	7,342,754 B2	3/2008	Fitzgerald et al.
6,997,931 B2	2/2006	Sauer et al.	7,344,268 B2	3/2008	Jhigamian
7,001,381 B2	2/2006	Harano et al.	D567,943 S	4/2008	Moses et al.
7,011,657 B2	3/2006	Truckai et al.	7,367,976 B2	5/2008	Lawes et al.
7,033,354 B2	4/2006	Keppel	7,377,920 B2	5/2008	Buysse et al.
7,033,356 B2	4/2006	Latterell et al.	7,384,420 B2	6/2008	Dycus et al.
7,041,102 B2	5/2006	Truckai et al.	7,384,421 B2	6/2008	Hushka
7,044,948 B2	5/2006	Keppel	7,396,336 B2	7/2008	Orszulak et al.
7,052,489 B2	5/2006	Griego et al.	D575,395 S	8/2008	Hushka
7,052,496 B2	5/2006	Yamauchi	D575,401 S	8/2008	Hixson et al.
7,063,715 B2	6/2006	Onuki et al.	7,435,249 B2	10/2008	Buysse et al.
D525,361 S	7/2006	Hushka	7,442,193 B2	10/2008	Shields et al.
7,070,597 B2	7/2006	Truckai et al.	7,442,194 B2	10/2008	Dumbauld et al.
7,083,618 B2	8/2006	Couture et al.	7,445,621 B2	11/2008	Dumbauld et al.
7,083,619 B2	8/2006	Truckai et al.	7,458,972 B2	12/2008	Keppel
7,083,620 B2	8/2006	Jahns et al.	7,473,253 B2	1/2009	Dycus et al.
7,087,051 B2	8/2006	Bourne et al.	7,481,810 B2	1/2009	Dumbauld et al.
7,087,054 B2	8/2006	Truckai et al.	7,487,780 B2	2/2009	Hooven
7,090,673 B2	8/2006	Dycus et al.	7,491,201 B2	2/2009	Shields et al.
7,090,689 B2	8/2006	Nagase et al.	7,491,202 B2	2/2009	Odom et al.
7,101,371 B2	9/2006	Dycus et al.	7,500,975 B2	3/2009	Cunningham et al.
7,101,372 B2	9/2006	Dycus et al.	7,510,556 B2	3/2009	Nguyen et al.
7,101,373 B2	9/2006	Dycus et al.	7,513,898 B2	4/2009	Johnson et al.
7,103,947 B2	9/2006	Sartor et al.	7,540,872 B2	6/2009	Schechter et al.
7,107,124 B2	9/2006	Green	7,549,995 B2	6/2009	Schultz
7,112,199 B2	9/2006	Cosmescu	7,553,312 B2	6/2009	Tetzlaff et al.
D531,311 S	10/2006	Guerra et al.	8,016,827 B2	9/2011	Chojin
7,115,123 B2	10/2006	Knowlton et al.	8,114,122 B2	2/2012	Nau, Jr.
7,118,570 B2	10/2006	Tetzlaff et al.	8,142,473 B2	3/2012	Cunningham
7,118,587 B2	10/2006	Dycus et al.	8,162,973 B2	4/2012	Cunningham
7,131,860 B2	11/2006	Sartor et al.	8,197,479 B2	6/2012	Olson et al.
7,131,970 B2	11/2006	Moses et al.	8,226,650 B2	7/2012	Kerr
7,131,971 B2	11/2006	Dycus et al.	8,251,994 B2	8/2012	McKenna et al.
7,135,020 B2	11/2006	Lawes et al.	8,257,387 B2	9/2012	Cunningham
D533,942 S	12/2006	Kerr et al.	8,282,634 B2	10/2012	Cunningham et al.
7,145,757 B2	12/2006	Shea et al.	2002/0013583 A1	1/2002	Camran et al.
7,147,638 B2	12/2006	Chapman et al.	2002/0049442 A1	4/2002	Roberts et al.
7,150,097 B2	12/2006	Sremcich et al.	2002/0099372 A1	7/2002	Schulze et al.
7,150,749 B2	12/2006	Dycus et al.	2002/0107517 A1	8/2002	Witt et al.
7,153,314 B2	12/2006	Laufer et al.	2002/0111624 A1	8/2002	Witt et al.
D535,027 S	1/2007	James et al.	2002/0188294 A1	12/2002	Couture et al.
7,156,842 B2	1/2007	Sartor et al.	2003/0014052 A1	1/2003	Buysse et al.
7,156,846 B2	1/2007	Dycus et al.	2003/0014053 A1	1/2003	Nguyen et al.
7,160,298 B2	1/2007	Lawes et al.	2003/0018331 A1	1/2003	Dycus et al.
7,160,299 B2	1/2007	Baily	2003/0018332 A1	1/2003	Schmaltz et al.
7,169,146 B2	1/2007	Truckai et al.	2003/0069570 A1	4/2003	Witzel et al.
7,179,255 B2	2/2007	Lettice et al.	2003/0069571 A1	4/2003	Treat et al.
7,179,258 B2	2/2007	Buysse et al.	2003/0078578 A1	4/2003	Truckai et al.
7,195,631 B2	3/2007	Dumbauld	2003/0109875 A1	6/2003	Tetzlaff et al.
D541,418 S	4/2007	Schechter et al.	2003/0114851 A1	6/2003	Truckai et al.
7,207,990 B2	4/2007	Lands et al.	2003/0139741 A1	7/2003	Goble et al.
D541,938 S	5/2007	Kerr et al.	2003/0139742 A1	7/2003	Wampler et al.
7,223,264 B2	5/2007	Daniel et al.	2003/0158548 A1	8/2003	Phan et al.
			2003/0158549 A1	8/2003	Swanson
			2003/0171747 A1	9/2003	Kanehira et al.
			2003/0181910 A1	9/2003	Dycus et al.
			2003/0199869 A1	10/2003	Johnson et al.

(56)

References Cited

U.S. PATENT DOCUMENTS

2003/0216732	A1	11/2003	Truckai et al.	2006/0167450	A1	7/2006	Johnson et al.
2003/0220637	A1	11/2003	Truckai et al.	2006/0167452	A1	7/2006	Moses et al.
2003/0229344	A1	12/2003	Dycus et al.	2006/0173452	A1	8/2006	Buyse et al.
2003/0236325	A1	12/2003	Bonora	2006/0189980	A1	8/2006	Johnson et al.
2003/0236518	A1	12/2003	Marchitto et al.	2006/0189981	A1	8/2006	Dycus et al.
2004/0030330	A1	2/2004	Brassell et al.	2006/0190035	A1	8/2006	Hushka et al.
2004/0030332	A1	2/2004	Knowlton et al.	2006/0217709	A1	9/2006	Couture et al.
2004/0049185	A1	3/2004	Latterell et al.	2006/0224158	A1	10/2006	Odom et al.
2004/0064151	A1	4/2004	Mollenauer	2006/0229666	A1	10/2006	Suzuki et al.
2004/0073238	A1	4/2004	Makower	2006/0253126	A1	11/2006	Bjerken et al.
2004/0073256	A1	4/2004	Marchitto et al.	2006/0259036	A1	11/2006	Tetzlaff et al.
2004/0078035	A1	4/2004	Kanehira et al.	2006/0264922	A1	11/2006	Sartor et al.
2004/0115296	A1	6/2004	Duffin	2006/0264931	A1	11/2006	Chapman et al.
2004/0116979	A1	6/2004	Truckai et al.	2006/0271038	A1	11/2006	Johnson et al.
2004/0122423	A1*	6/2004	Dycus A61B 18/1445 606/51	2006/0283093	A1	12/2006	Petrovic et al.
2004/0143263	A1	7/2004	Schechter et al.	2006/0287641	A1	12/2006	Perlin
2004/0147925	A1	7/2004	Buyse et al.	2007/0016182	A1	1/2007	Lipson et al.
2004/0148035	A1	7/2004	Barrett et al.	2007/0016187	A1	1/2007	Weinberg et al.
2004/0162557	A1	8/2004	Tetzlaff et al.	2007/0043352	A1	2/2007	Garrison et al.
2004/0199181	A1	10/2004	Knodel et al.	2007/0043353	A1	2/2007	Dycus et al.
2004/0210282	A1	10/2004	Flock et al.	2007/0055231	A1	3/2007	Dycus et al.
2004/0224590	A1	11/2004	Rawa et al.	2007/0060919	A1	3/2007	Isaacson et al.
2004/0225288	A1	11/2004	Buyse et al.	2007/0062017	A1	3/2007	Dycus et al.
2004/0230189	A1	11/2004	Keppel	2007/0074807	A1	4/2007	Guerra
2004/0236325	A1	11/2004	Tetzlaff et al.	2007/0078456	A1	4/2007	Dumbauld et al.
2004/0236326	A1	11/2004	Schulze et al.	2007/0078458	A1	4/2007	Dumbauld et al.
2004/0243125	A1	12/2004	Dycus et al.	2007/0078459	A1	4/2007	Johnson et al.
2004/0249371	A1	12/2004	Dycus et al.	2007/0088356	A1	4/2007	Moses et al.
2004/0249374	A1	12/2004	Tetzlaff et al.	2007/0106295	A1	5/2007	Garrison et al.
2004/0250419	A1	12/2004	Sremcich et al.	2007/0106297	A1	5/2007	Dumbauld et al.
2004/0254573	A1	12/2004	Dycus et al.	2007/0118111	A1	5/2007	Weinberg
2004/0260281	A1	12/2004	Baxter, III et al.	2007/0118115	A1	5/2007	Artale et al.
2005/0004564	A1	1/2005	Wham et al.	2007/0142833	A1	6/2007	Dycus et al.
2005/0004568	A1	1/2005	Lawes et al.	2007/0142834	A1	6/2007	Dumbauld
2005/0004569	A1	1/2005	Witt et al.	2007/0156139	A1	7/2007	Schechter et al.
2005/0004570	A1	1/2005	Chapman et al.	2007/0156140	A1	7/2007	Baily
2005/0021025	A1	1/2005	Buyse et al.	2007/0173811	A1	7/2007	Couture et al.
2005/0021026	A1	1/2005	Baily	2007/0173814	A1	7/2007	Hixson et al.
2005/0021027	A1	1/2005	Shields et al.	2007/0179499	A1	8/2007	Garrison
2005/0033278	A1	2/2005	McClurken et al.	2007/0198011	A1	8/2007	Sugita
2005/0059934	A1	3/2005	Wenchell et al.	2007/0203485	A1	8/2007	Keppel
2005/0096645	A1	5/2005	Wellman et al.	2007/0213706	A1	9/2007	Dumbauld et al.
2005/0101951	A1	5/2005	Wham et al.	2007/0213707	A1	9/2007	Dumbauld et al.
2005/0101952	A1	5/2005	Lands et al.	2007/0213708	A1	9/2007	Dumbauld et al.
2005/0107784	A1	5/2005	Moses et al.	2007/0213712	A1	9/2007	Buyse et al.
2005/0107785	A1	5/2005	Dycus et al.	2007/0255279	A1	11/2007	Buyse et al.
2005/0113818	A1	5/2005	Sartor et al.	2007/0260235	A1	11/2007	Podhajsky
2005/0113819	A1	5/2005	Wham et al.	2007/0260238	A1	11/2007	Guerra
2005/0113826	A1	5/2005	Johnson et al.	2007/0260241	A1	11/2007	Dalla Betta et al.
2005/0113827	A1	5/2005	Dumbauld et al.	2007/0260242	A1	11/2007	Dycus et al.
2005/0113828	A1	5/2005	Shields et al.	2007/0265616	A1	11/2007	Couture et al.
2005/0119655	A1	6/2005	Moses et al.	2008/0004616	A1	1/2008	Patrick
2005/0137590	A1	6/2005	Lawes et al.	2008/0009860	A1	1/2008	Odom
2005/0149017	A1	7/2005	Dycus	2008/0015575	A1	1/2008	Odom et al.
2005/0149151	A1	7/2005	Orszulak et al.	2008/0021450	A1	1/2008	Couture
2005/0154387	A1	7/2005	Moses et al.	2008/0033428	A1	2/2008	Artale et al.
2005/0187547	A1	8/2005	Sugi	2008/0039835	A1	2/2008	Johnson et al.
2005/0197659	A1	9/2005	Bahney	2008/0039836	A1	2/2008	Odom et al.
2005/0203504	A1	9/2005	Wham et al.	2008/0045947	A1	2/2008	Johnson et al.
2005/0240179	A1	10/2005	Buyse et al.	2008/0058802	A1	3/2008	Couture et al.
2006/0052778	A1	3/2006	Chapman et al.	2008/0082100	A1	4/2008	Orton et al.
2006/0052779	A1	3/2006	Hammill	2008/0091189	A1	4/2008	Carlton
2006/0064085	A1	3/2006	Schechter et al.	2008/0195093	A1	8/2008	Couture et al.
2006/0064086	A1	3/2006	Odom	2008/0215051	A1	9/2008	Buyse et al.
2006/0074417	A1	4/2006	Cunningham et al.	2008/0243120	A1	10/2008	Lawes et al.
2006/0079888	A1	4/2006	Mulier et al.	2008/0249527	A1	10/2008	Couture
2006/0079890	A1	4/2006	Guerra	2008/0312653	A1	12/2008	Arts et al.
2006/0079891	A1	4/2006	Arts et al.	2008/0319442	A1	12/2008	Unger et al.
2006/0079933	A1	4/2006	Hushka et al.	2009/0012520	A1	1/2009	Hixson et al.
2006/0084973	A1	4/2006	Hushka	2009/0018535	A1	1/2009	Schechter et al.
2006/0089670	A1	4/2006	Hushka	2009/0024126	A1	1/2009	Artale et al.
2006/0116675	A1	6/2006	McClurken et al.	2009/0043304	A1	2/2009	Tetzlaff et al.
2006/0129146	A1	6/2006	Dycus et al.	2009/0048596	A1	2/2009	Shields et al.
2006/0161150	A1	7/2006	Keppel	2009/0062794	A1	3/2009	Buyse et al.
				2009/0082766	A1	3/2009	Unger et al.
				2009/0082767	A1	3/2009	Unger et al.
				2009/0082769	A1	3/2009	Unger et al.
				2009/0088738	A1	4/2009	Guerra et al.
				2009/0088739	A1	4/2009	Hushka et al.

(56)

References Cited

U.S. PATENT DOCUMENTS

2009/0088740 A1 4/2009 Guerra et al.
 2009/0088741 A1 4/2009 Hushka et al.
 2009/0088744 A1 4/2009 Townsend
 2009/0088745 A1 4/2009 Hushka et al.
 2009/0088746 A1 4/2009 Hushka et al.
 2009/0088747 A1 4/2009 Hushka et al.
 2009/0088748 A1 4/2009 Guerra et al.
 2009/0088749 A1 4/2009 Hushka et al.
 2009/0088750 A1 4/2009 Hushka et al.
 2009/0112206 A1 4/2009 Dumbauld et al.
 2009/0131934 A1 5/2009 Odom et al.
 2009/0149853 A1 6/2009 Shields et al.
 2009/0149854 A1 6/2009 Cunningham et al.
 2009/0171350 A1 7/2009 Dycus et al.
 2009/0171353 A1 7/2009 Johnson et al.
 2009/0182327 A1 7/2009 Unger
 2009/0187188 A1 7/2009 Guerra et al.
 2009/0198233 A1 8/2009 Chojin
 2009/0209957 A1 8/2009 Schmaltz et al.
 2009/0209960 A1 8/2009 Chojin
 2009/0234354 A1 9/2009 Johnson et al.
 2009/0248021 A1 10/2009 McKenna
 2010/0016857 A1 1/2010 McKenna et al.
 2010/0036375 A1 2/2010 Regadas
 2010/0042143 A1 2/2010 Cunningham
 2010/0049187 A1 2/2010 Carlton et al.
 2010/0057081 A1 3/2010 Hanna
 2010/0057082 A1 3/2010 Hanna
 2010/0057083 A1 3/2010 Hanna
 2010/0057084 A1 3/2010 Hanna
 2010/0063500 A1 3/2010 Muszala
 2010/0069903 A1 3/2010 Allen, IV et al.
 2010/0069904 A1 3/2010 Cunningham
 2010/0069953 A1 3/2010 Cunningham et al.
 2010/0076427 A1 3/2010 Heard
 2010/0076430 A1 3/2010 Romero
 2010/0076431 A1 3/2010 Allen, IV
 2010/0076432 A1 3/2010 Horner
 2010/0087816 A1 4/2010 Roy
 2010/0094287 A1 4/2010 Cunningham et al.
 2010/0100122 A1 4/2010 Hinton
 2010/0179545 A1 7/2010 Twomey et al.
 2010/0179546 A1 7/2010 Cunningham

FOREIGN PATENT DOCUMENTS

DE 2415263 10/1975
 DE 2415263 A1 10/1975
 DE 2514501 10/1976
 DE 02514501 A1 10/1976
 DE 2627679 1/1977
 DE 2627679 A1 1/1977
 DE 3612646 4/1987
 DE 03612646 A1 4/1987
 DE 8712328 U1 2/1988
 DE 8712328 3/1988
 DE 4303882 8/1994
 DE 04303882 C2 2/1995
 DE 4403252 8/1995
 DE 04403252 A1 8/1995
 DE 19515914 7/1996
 DE 19515914 C1 7/1996
 DE 29616210 U1 11/1996
 DE 29616210 1/1997
 DE 19608716 4/1997
 DE 19608716 C1 4/1997
 DE 19751106 5/1998
 DE 19751106 A1 5/1998
 DE 19751108 5/1999
 DE 19751108 A1 5/1999
 DE 19738457 1/2009
 DE 19738457 B4 1/2009
 EP 0364216 4/1990
 EP 0467501 1/1992
 EP 0467501 A1 1/1992

EP 0518230 12/1992
 EP 0541930 5/1993
 EP 0572131 12/1993
 EP 0572131 A1 12/1993
 EP 0584787 3/1994
 EP 0584787 A1 3/1994
 EP 0589453 3/1994
 EP 0589555 3/1994
 EP 0589555 A1 3/1994
 EP 0589453 A3 4/1994
 EP 0623316 11/1994
 EP 0624348 11/1994
 EP 0650701 5/1995
 EP 0624348 A3 6/1995
 EP 0364216 B1 1/1996
 EP 0694290 3/1996
 EP 0518230 B1 5/1996
 EP 0717966 6/1996
 EP 0754437 3/1997
 EP 0517243 9/1997
 EP 0517243 B1 9/1997
 EP 0541930 B1 3/1998
 EP 0853922 7/1998
 EP 0875209 11/1998
 EP 0878169 11/1998
 EP 0878169 A1 11/1998
 EP 0887046 1/1999
 EP 0623316 B1 3/1999
 EP 0650701 B1 3/1999
 EP 0923907 6/1999
 EP 0923907 A1 6/1999
 EP 0986990 3/2000
 EP 0986990 A1 3/2000
 EP 1034747 9/2000
 EP 1034747 A1 9/2000
 EP 1034748 9/2000
 EP 1025807 10/2000
 EP 1034746 10/2000
 EP 0694290 B1 11/2000
 EP 1050278 11/2000
 EP 1053719 11/2000
 EP 1053720 11/2000
 EP 1055399 11/2000
 EP 1055400 11/2000
 EP 1080694 3/2001
 EP 1082944 3/2001
 EP 1159926 12/2001
 EP 1177771 2/2002
 EP 1159926 A3 3/2003
 EP 0717966 B1 4/2003
 EP 1301135 4/2003
 EP 0887046 B1 7/2003
 EP 1330991 7/2003
 EP 1330991 A1 7/2003
 EP 1486177 6/2004
 EP 1472984 11/2004
 EP 0754437 B2 12/2004
 EP 1025807 B1 12/2004
 EP 0774232 1/2005
 EP 0774232 B1 1/2005
 EP 0853922 B1 2/2005
 EP 1527747 5/2005
 EP 1530952 5/2005
 EP 1530952 A1 5/2005
 EP 1532932 5/2005
 EP 1535581 6/2005
 EP 1609430 12/2005
 EP 1034746 B1 3/2006
 EP 1632192 3/2006
 EP 1642543 4/2006
 EP 1645238 4/2006
 EP 1645238 A1 4/2006
 EP 1645240 4/2006
 EP 1649821 4/2006
 EP 0875209 B1 5/2006
 EP 1707143 10/2006
 EP 1707143 A1 10/2006
 EP 1769765 4/2007
 EP 1769765 A1 4/2007

(56)

References Cited

FOREIGN PATENT DOCUMENTS

EP	1769766	4/2007
EP	1929970	6/2008
EP	1683496	12/2008
GB	623316	5/1949
GB	1490585	11/1977
GB	2214430 A	6/1989
GB	2213416 A	8/1989
GB	2214430 A	9/1989
JP	61-501068	9/1984
JP	501068	9/1984
JP	6-502328	3/1992
JP	502328	3/1992
JP	5-5106	1/1993
JP	05-40112	2/1993
JP	06343644	12/1994
JP	06343644 A	12/1994
JP	07265328	10/1995
JP	07265328 A	10/1995
JP	08056955	3/1996
JP	08056955 A	3/1996
JP	08252263	10/1996
JP	08252263 A	10/1996
JP	09010223	1/1997
JP	09010223 A	1/1997
JP	11244298	9/1999
JP	11244298 A	9/1999
JP	2000-350732	12/2000
JP	2000342599	12/2000
JP	2000342599 A	12/2000
JP	2000350732 A	12/2000
JP	2001-008944	1/2001
JP	2001008944 A	1/2001
JP	2001-029356	2/2001
JP	2001029356 A	2/2001
JP	20011029356	2/2001
JP	2001-128990	5/2001
JP	2001128990 A	5/2001
SU	401367 A1	10/1973
SU	401367	11/1974
WO	89/00757	1/1989
WO	92/04873	4/1992
WO	92/06642	4/1992
WO	93/21845	11/1993
WO	94/08524	4/1994
WO	94/20025	9/1994
WO	95/02369	1/1995
WO	95/07662	3/1995
WO	95/15124	6/1995
WO	96/05776	2/1996
WO	96-22056 A1	7/1996
WO	WO 96/22056	7/1996
WO	96/13218	9/1996
WO	97/00646	1/1997
WO	97/00647	1/1997
WO	97/10764	3/1997
WO	97/24073	7/1997
WO	97/24993	7/1997
WO	98/27880	7/1998
WO	99/03407	1/1999
WO	99/03408	1/1999
WO	99/03409	1/1999
WO	99/12488	3/1999
WO	99-23933 A2	5/1999
WO	WO 99/23933	5/1999
WO	99/40857	8/1999
WO	99/40861	8/1999
WO	99/51158	10/1999
WO	99/66850	12/1999
WO	00/24330	5/2000
WO	00/24331	5/2000
WO	0036986 A1	6/2000
WO	WO 00/36986	6/2000
WO	00/41638	7/2000
WO	00/47124	8/2000
WO	00/53112	9/2000

WO	01/17448	3/2001
WO	0154604 A1	8/2001
WO	WO 01/54604	8/2001
WO	02/07627	1/2002
WO	02/067798	9/2002
WO	02/080783	10/2002
WO	02/080784	10/2002
WO	02/080785	10/2002
WO	02/080786	10/2002
WO	02/080793	10/2002
WO	02/080794	10/2002
WO	02/080795	10/2002
WO	02/080796	10/2002
WO	02/080797	10/2002
WO	02/080798	10/2002
WO	02/080799 A1	10/2002
WO	02/081170	10/2002
WO	03/101311	12/2003
WO	03/090630 A3	4/2004
WO	2004/032776 A1	4/2004
WO	2004/032777 A1	4/2004
WO	2004/052221 A1	6/2004
WO	2004/073488 A2	9/2004
WO	2004/073490 A2	9/2004
WO	2004/073753 A2	9/2004
WO	2004/082495 A1	9/2004
WO	2004/098383 A2	11/2004
WO	2004/103156 A2	12/2004
WO	2005/004734 A1	1/2005
WO	2005/004735 A1	1/2005
WO	2005/110264 A2	11/2005

OTHER PUBLICATIONS

International Search Report EP 98958575.7 dated Sep. 20, 2002.
 International Search Report EP 05013895 dated Oct. 14, 2005.
 International Search Report EP 05017281 dated Nov. 16, 2005.
 Int'l Search Report EP 05013463.4 dated Sep. 28, 2005.
 Int'l Search Report EP 05021779.3 dated Jan. 18, 2006.
 Int'l Search Report EP 05021197.8 dated Jan. 31, 2006.
 Int'l Search Report—extended—EP 05021937.7 dated Mar. 6, 2006.
 Int'l Search Report EP 05021780.1 dated Feb. 9, 2006.
 Int'l Search Report EP 06005185.1 dated Apr. 18, 2006.
 Int'l Search Report EP 06008779.8 dated Jun. 13, 2006.
 Int'l Search Report EP 1683496 dated Jun. 13, 2006.
 Int'l Search Report EP 06020584.6 dated Jan. 12, 2007.
 Int'l Search Report EP 06020583.8 dated Jan. 30, 2007.
 Int'l Search Report EP 06020756.0 dated Feb. 5, 2007.
 PCT/US01/11340 International Search Report dated Jun. 4, 2001.
 PCT/US02/01890 International Search Report dated Jan. 22, 2002.
 PCT/US02/11100 International Search Report dated Jul. 9, 2002.
 PCT/US04/03436 International Search Report dated Feb. 6, 2004.
 PCT/US04/13273 International Search Report dated Apr. 29, 2004.
 PCT/US04/15311 International Search Report dated May 14, 2004.
 EP 98944778 International Search Report dated Nov. 7, 2000.
 EP 98958575 International Search Report dated Oct. 29, 2002.
 EP 04027479 International Search Report dated Mar. 17, 2005.
 EP 04027705 International Search Report dated Feb. 10, 2005.
 EP 04027314 International Search Report dated Mar. 31, 2005.
 PCT/US01/11218 International Search Report dated Apr. 6, 2001.
 PCT/US99/24869 International Search Report dated Oct. 22, 1999.
 PCT/US98/18640 International Search Report dated Sep. 8, 1998.
 PCT/US98/23950 International Search Report dated Nov. 11, 1998.
 McLellan et al. "Vessel Sealing for Hemostasis During Pelvic Surgery", 1999.
 "Reducing Needlestick Injuries in the Operating Room", 2001.
 McLellan et al. "Vessel Sealing for Hemostasis During Gynecologic Surgery", 1999.
 E. David Crawford "Use of a Novel Vessel Sealing Technology in Management of the Dorsal Venous Complex", 2000.
 E. David Crawford "Evaluation of a New Vessel Sealing Device in Urologic Cancer Surgery", 2000.
 Int'l Search Report EP 06 024122.1 dated Mar. 19, 2007.
 Int'l Search Report EP 07 001480.8 dated Apr. 12, 2007.

(56)

References Cited

OTHER PUBLICATIONS

- Int'l Search Report EP 07 001488.1 dated May 29, 2007.
- Int'l Search Report—Extended EP 07 009029.5 dated Jul. 12, 2007.
- Int'l Search Report EP 06 020574.7 dated Sep. 21, 2007.
- Int'l Search Report EP 07 009026.1 dated Sep. 12, 2007.
- Int'l Search Report EP 07 020283.3 dated Jan. 16, 2008.
- Johnson et al. "Evaluation of a Bipolar Electrothermal Vessel Sealing Device in Hemorrhoidectomy" Sales/Product Literature; Jan. 2004.
- Linehan et al. "A Phase I Study of the LigaSure Vessel Sealing System in Hepatic Surgery" Section of HPB Surger, Washington University School of Medicine, St. Louis MO, Presented at AHPBA, Feb. 2001.
- Paul G. Horgan, "A Novel Technique for Parenchymal Division During Hepatectomy" The American Journal of Surgery, vol. 181, No. 3, quadrature. Apr. 2001 pp. 236-237.
- Carus et al., "Initial Experience With The LigaSure Vessel Sealing System in Abdominal Surgery" Innovations That Work, quadrature. Jun. 2002.
- LigaSure Vessel Sealing System, the Seal of Confidence in General, Gynecologic, Urologic, and Laparoscopic Surgery Sales/Product Literature; Jan. 2004.
- International Search Report PCT/US01/11224 dated Nov. 13, 2001. Examiner's Report issued in Australia in Application No. 2009201853 dated Aug. 26, 2011.
- Michael Choti, "Abdominoperineal Resection with the LigaSure Vessel Sealing System and LigaSure Atlas 20 cm Open Instrument"; Innovations That Work, Jun. 2003.
- Chung et al., "Clinical Experience of Sutureless Closed Hemorrhoidectomy with LigaSure" Diseases of the Colon & Rectum vol. 46, No. 1 Jan. 2003.
- Carbonell et al., "Comparison of the Gyrus PlasmaKinetic Sealer and the Valleylab LigaSure Device in the Hemostasis of Small, Medium, and Large-Sized Arteries" Carolinas Laparoscopic and Advanced Surgery Program, Carolinas Medical Center, Charlotte, NC; Date: Aug. 2003.
- Peterson et al. "Comparison of Healing Process Following Ligation with Sutures and Bipolar Vessel Sealing" Surgical Technology International (2001).
- "Electrosurgery: A Historical Overview" Innovations in Electrosurgery; Sales/Product Literature; Dec. 31, 2000.
- Johnson et al. "Evaluation of a Bipolar Electrothermal Vessel Sealing Device in Hemorrhoidectomy" Sales/Product Literature; Jan. 2004.
- E. David Crawford "Evaluation of a New Vessel Sealing Device in Urologic Cancer Surgery" Sales/Product Literature 2000.
- Johnson et al. "Evaluation of the LigaSure Vessel Sealing System in Hemorrhoidectomy" American College of Surgeons (ACS) Clinica Congress Poster (2000).
- Muller et al., "Extended Left Hemicolectomy Using the LigaSure Vessel Sealing System" Innovations That Work, Sep. 1999.
- Kennedy et al. "High-burst-strength, feedback-controlled bipolar vessel sealing" Surgical Endoscopy (1998) 12: 876-878.
- Carus et al., "Initial Experience With the LigaSure Vessel Sealing System in Abdominal Surgery" Innovations That Work, Jun. 2002.
- Heniford et al. "Initial Research and Clinical Results with an Electrothermal Bipolar Vessel Sealer" Oct. 1999.
- Heniford et al. "Initial Results with an Electrothermal Bipolar Vessel Sealer" Surgical Endoscopy (2000) 15:799-801.
- Herman et al., "Laparoscopic Intestinal Resection With the LigaSure Vessel Sealing System: A Case Report"; Innovations That Work, Feb. 2002.
- Koyle et al., "Laparoscopic Palomo Varicocele Ligation in Children and Adolescents" Pediatric Endosurgery & Innovative Techniques, vol. 6, No. 1, 2002.
- W. Scott Helton, "LigaSure Vessel Sealing System: Revolutionary Hemostasis Product for General Surgery"; Sales/Product Literature 1999.
- LigaSure Vessel Sealing System, the Seal of Confidence in General, Gynecologic, Urologic, and Laparoscopic Surgery; Sales/Product Literature; Apr. 2002.
- Joseph Ortenberg "LigaSure System Used in Laparoscopic 1st and 2nd Stage Orchiopexy" Innovations That Work, Nov. 2002.
- Sigel et al. "The Mechanism of Blood Vessel Closure by High Frequency Electrocoagulation" Surgery Gynecology & Obstetrics, Oct. 1965 pp. 823-831.
- Sampayan et al, "Multilayer Ultra-High Gradient Insulator Technology" Discharges and Electrical Insulation in Vacuum, 1998. Netherlands Aug. 17-21, 1998; vol. 2, pp. 740-743.
- Paul G. Horgan, "A Novel Technique for Parenchymal Division During Hepatectomy" The American Journal of Surgery, vol. 181, No. 3, Apr. 2001 pp. 236-237.
- Olsson et al. "Radical Cystectomy in Females" Current Surgical Techniques in Urology, vol. 14, Issue 3, 2001.
- Palazzo et al. "Randomized clinical trial of Ligasure versus open haemorrhoidectomy" British Journal of Surgery 2002, 89, 154-157.
- Levy et al. "Randomized Trial of Suture Versus Electrosurgical Bipolar Vessel Sealing in Vaginal Hysterectomy" Obstetrics & Gynecology, vol. 102, No. 1, Jul. 2003.
- "Reducing Needlestick Injuries in the Operating Room" Sales/Product Literature 2001.
- Bergdahl et al. "Studies on Coagulation and the Development of an Automatic Computerized Bipolar Coagulator" J.Neurosurg, vol. 75, Jul. 1991, pp. 148-151.
- Strasberg et al. "A Phase I Study of the LigaSure Vessel Sealing System in Hepatic Surgery" Section of HPB Surger, Washington University School of Medicine, St. Louis MO, Presented at AHPBA, Feb. 2001.
- Sayfan et al. "Sutureless Closed Hemorrhoidectomy: A New Technique" Annals of Surgery vol. 234 No. 1 Jul. 2001; pp. 21-24.
- Levy et al., "Update on Hysterectomy—New Technologies and Techniques". OBG Management, Feb. 2003.
- Dulemba et al. "Use of a Bipolar Electrothermal Vessel Sealer in Laparoscopically Assisted Vaginal Hysterectomy" Sales/Product Literature; Jan. 2004.
- Strasberg et al., "Use of a Bipolar Vessel-Sealing Device for Parenchymal Transection During Liver Surgery" Journal of Gastrointestinal Surgery, vol. 6, No. 4, Jul./Aug. 2002 pp. 569-574.
- Sengupta et al., "Use of a Computer-Controlled Bipolar Diathermy System in Radical Prostatectomies and Other Open Urological Surgery" ANZ Journal of Surgery (2001) 71.9 pp. 538-540.
- Rothenberg et al. "Use of the LigaSure Vessel Sealing System in Minimally Invasive Surgery in Children" Int'l Pediatric Endosurgery Group (IPEG) 2000.
- Crawford et al. "Use of the LigaSure Vessel Sealing System in Urologic Cancer Surgery" Grand Rounds in Urology 1999 vol. 1 Issue 4 pp. 10-17.
- Craig Johnson, "Use of the LigaSure Vessel Sealing System in Bloodless Hemorrhoidectomy" Innovations That Work, Mar. 2000.
- Levy et al. "Use of a New Energy-based Vessel Ligation Device During Vaginal Hysterectomy" Int'l Federation of Gynecology and Obstetrics (FIGO) World Congress 1999.
- Barbara Levy, "Use of a New Vessel Ligation Device During Vaginal Hysterectomy" FIGO 2000, Washington, D.C.
- E. David Crawford "Use of a Novel Vessel Sealing Technology in Management of the Dorsal Venous Complex" Sales/Product Literature 2000.
- Jarrett et al., "Use of the LigaSure Vessel Sealing System for Peri-Hilar Vessels in Laparoscopic Nephrectomy" Sales/Product Literature 2000.
- Crouch et al. "A Velocity-Dependent Model for Needle Insertion in Soft Tissue" MICCAI 2005; LNCS 3750 pp. 624-632, Dated: 2005.
- McLellan et al. "Vessel Sealing for Hemostasis During Pelvic Surgery" Int'l Federation of Gynecology and Obstetrics FIGO World Congress 2000, Washington, D.C.
- McLellan et al. "Vessel Sealing for Hemostasis During Gynecologic Surgery" Sales/Product Literature 1999.
- Int'l Search Report EP 98944778.4 dated Oct. 31, 2000.
- Int'l Search Report EP 98957771 dated Aug. 9, 2001.
- Int'l Search Report EP 98958575.7 dated Sep. 20, 2002.
- Int'l Search Report EP 04013772.1 dated Apr. 1, 2005.

(56)

References Cited

OTHER PUBLICATIONS

- Int'l Search Report EP 04027314.6 dated Mar. 10, 2005.
Int'l Search Report EP 04027479.7 dated Mar. 8, 2005.
Int'l Search Report EP 04027705.5 dated Feb. 3, 2005.
Int'l Search Report EP 04752343.6 dated Jul. 20, 2007.
Int'l Search Report EP 05002671.5 dated Dec. 22, 2008.
Int'l Search Report EP 05002674.9 dated Jan. 16, 2009.
Int'l Search Report EP 05013463.4 dated Oct. 7, 2005.
Int'l Search Report EP 05013895.7 dated Oct. 21, 2005.
Int'l Search Report EP 05016399.7 dated Jan. 13, 2006.
Int'l Search Report EP 05017281.6 dated Nov. 24, 2005.
Int'l Search Report EP 05019130.3 dated Oct. 27, 2005.
Int'l Search Report EP 05019429.9 dated May 6, 2008.
Int'l Search Report EP 05020665.5 dated Feb. 27, 2006.
Int'l Search Report EP 05020666.3 dated Feb. 27, 2006.
Int'l Search Report EP 05021197.8 dated Feb. 20, 2006.
Int'l Search Report EP 05021779.3 dated Feb. 2, 2006.
Int'l Search Report EP 05021780.1 dated Feb. 23, 2006.
Int'l Search Report EP 05021937.7 dated Jan. 23, 2006.
Int'l Search Report—extended—EP 05021937.7 dated Mar. 15, 2006.
Int'l Search Report EP 05023017.6 dated Feb. 24, 2006.
Int'l Search Report EP 06002279.5 dated Mar. 30, 2006.
Intl Search Report EP 06005185.1 dated May 10, 2006.
Int'l Search Report EP 06006716.2 dated Aug. 4, 2006.
Int'l Search Report EP 06008515.6 dated Jan. 8, 2009.
Int'l Search Report EP 06008779.8 dated Jul. 13, 2006.
Int'l Search Report EP 06014461.5 dated Oct. 31, 2006.
Int'l Search Report EP 06020574.7 dated Oct. 2, 2007.
Int'l Search Report EP 06020583.8 dated Feb. 7, 2007.
Int'l Search Report EP 06020584.6 dated Feb. 1, 2007.
Int'l Search Report EP 06020756.0 dated Feb. 16, 2007.
Int'l Search Report EP 06 024122.1 dated Apr. 16, 2007.
Int'l Search Report EP 06024123.9 dated Mar. 6, 2007.
Int'l Search Report EP 07 001480.8 dated Apr. 19, 2007.
Int'l Search Report EP 07 001488.1 dated Jun. 5, 2007.
Int'l Search Report EP 07 009026.1 dated Oct. 8, 2007.
Int'l Search Report Extended—EP 07 009029.5 dated Jul. 20, 2007.
Int'l Search Report EP 07 009321.6 dated Aug. 28, 2007.
Int'l Search Report EP 07 010672.9 dated Oct. 16, 2007.
Int'l Search Report EP 07 013779.9 dated Oct. 26, 2007.
Int'l Search Report EP 07 014016 dated Jan. 28, 2008.
Int'l Search Report EP 07 015191.5 dated Jan. 23, 2008.
Int'l Search Report EP 07 015601.3 dated Jan. 4, 2008.
Int'l Search Report EP 07 020283.3 dated Feb. 5, 2008.
Int'l Search Report EP 07 021646.0 dated Jul. 9, 2008.
Int'l Search Report EP 07 021647.8 dated May 2, 2008.
Int'l Search Report EP 08 002692.5 dated Dec. 12, 2008.
Int'l Search Report EP 08 004655.0 dated Jun. 24, 2008.
Int'l Search Report EP 08 006732.5 dated Jul. 29, 2008.
Int'l Search Report EP 08 006917.2 dated Jul. 3, 2008.
Int'l Search Report EP 08 016539.2 dated Jan. 8, 2009.
Int'l Search Report EP 09 152267.2 dated Jun. 15, 2009.
Int'l Search Report EP 09 152898.4 dated Jun. 10, 2009.
Int'l Search Report PCT/US98/18640 dated Jan. 29, 1999.
Int'l Search Report PCT/US98/23950 dated Jan. 14, 1999.
Int'l Search Report PCT/US98/24281 dated Feb. 22, 1999.
Int'l Search Report PCT/US99/24869 dated Feb. 3, 2000.
Int'l Search Report PCT/US01/11218 dated Aug. 14, 2001.
Int'l Search Report PCT/US01/11224 dated Nov. 13, 2001.
Int'l Search Report PCT/US01/11340 dated Aug. 16, 2001.
Int'l Search Report PCT/US01/11420 dated Oct. 16, 2001.
Int'l Search Report PCT/US02/01890 dated Jul. 25, 2002.
Int'l Search Report PCT/US02/11100 dated Jul. 16, 2002.
Int'l Search Report PCT/US03/28534 dated Dec. 19, 2003.
Int'l Search Report PCT/US04/03436 dated Mar. 3, 2005.
Int'l Search Report PCT/US04/13273 dated Dec. 15, 2004.
Int'l Search Report PCT/US04/15311 dated Jan. 12, 2005.
Int'l Search Report PCT/US07/021438 dated Apr. 1, 2008.
Int'l Search Report PCT/US07/021440 dated Apr. 8, 2008.
Int'l Search Report PCT/US08/61498 dated Sep. 22, 2008.
Int'l Search Report PCT/US09/032690 dated Jun. 16, 2009.

* cited by examiner

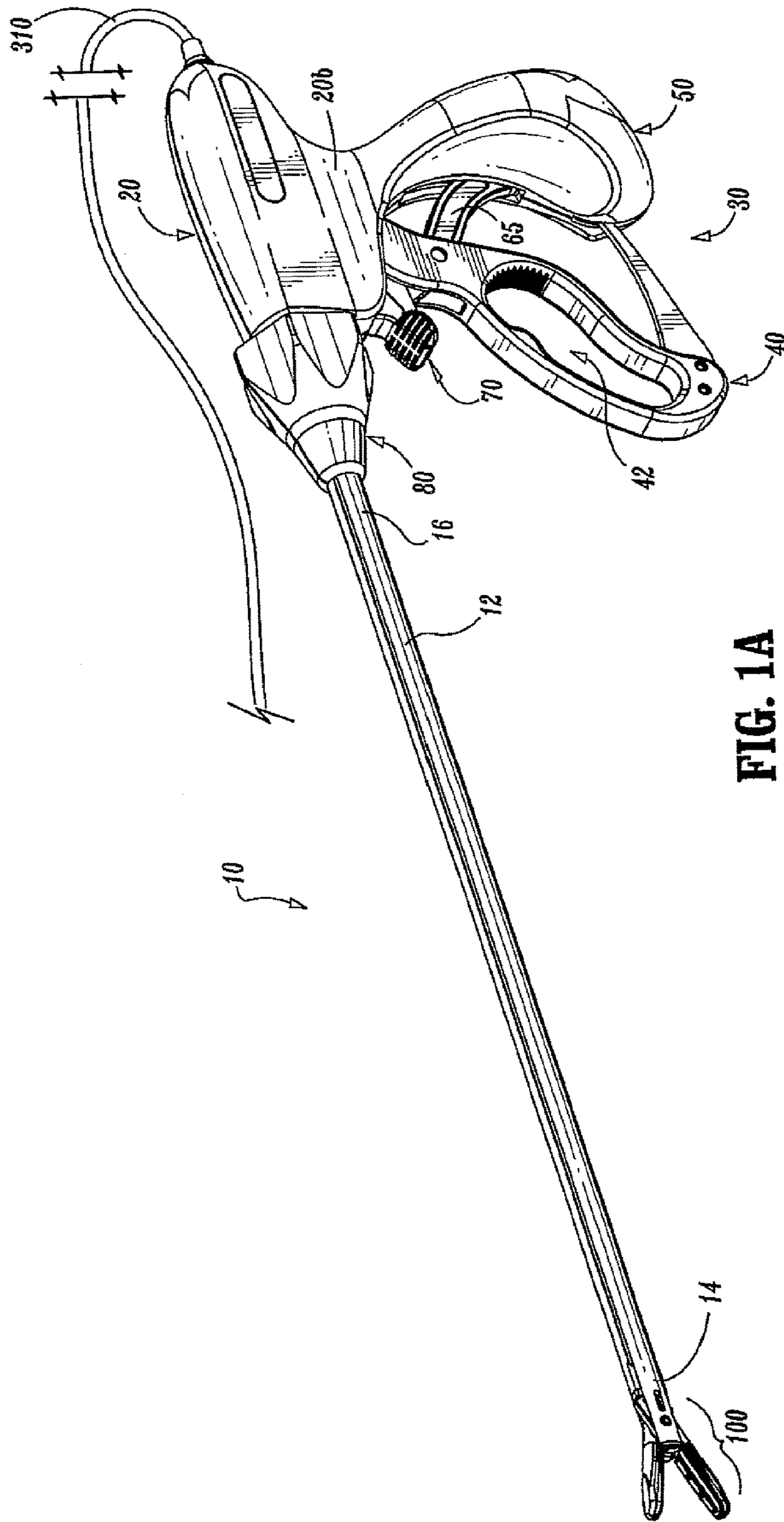

FIG. 1A

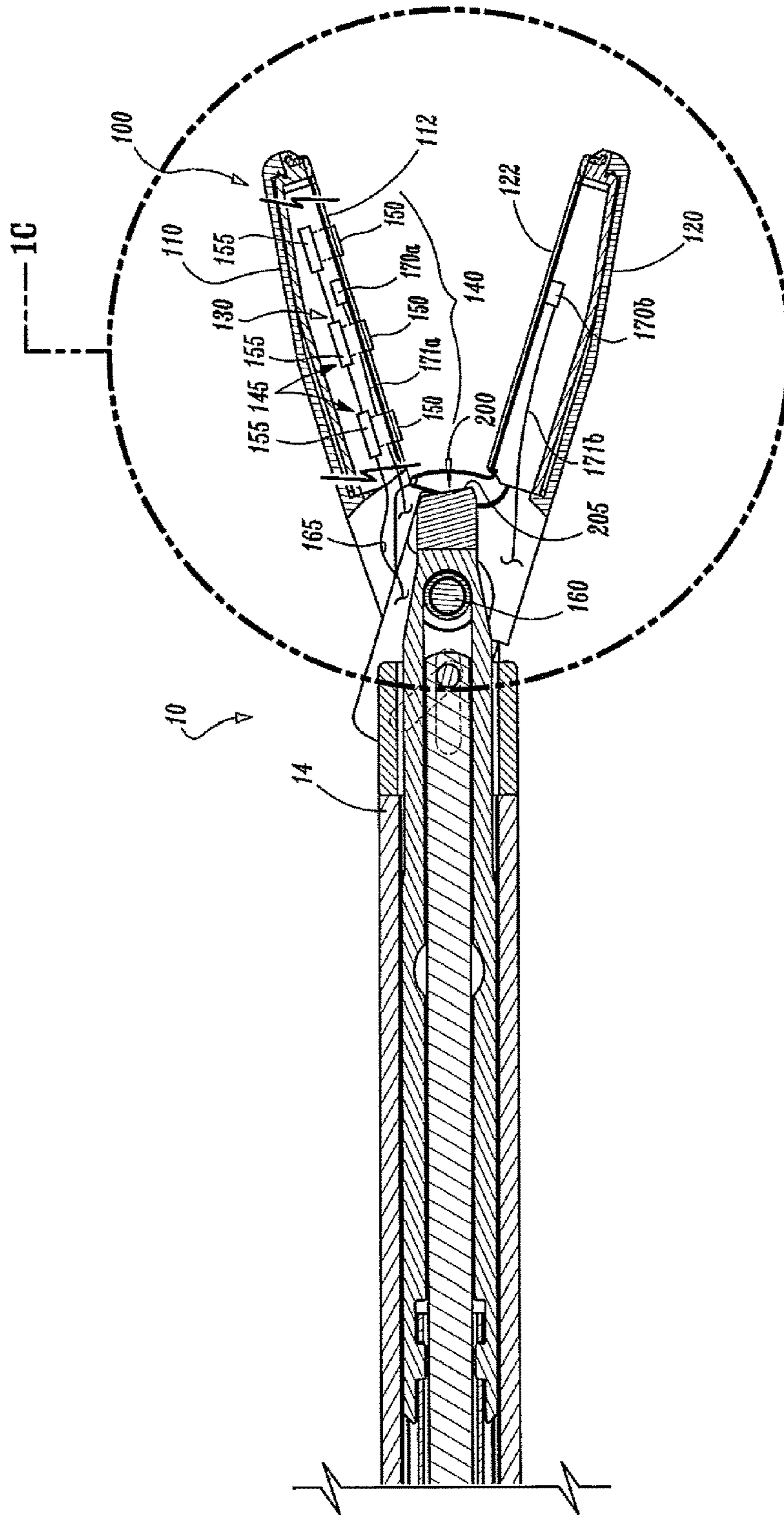

FIG. 1B

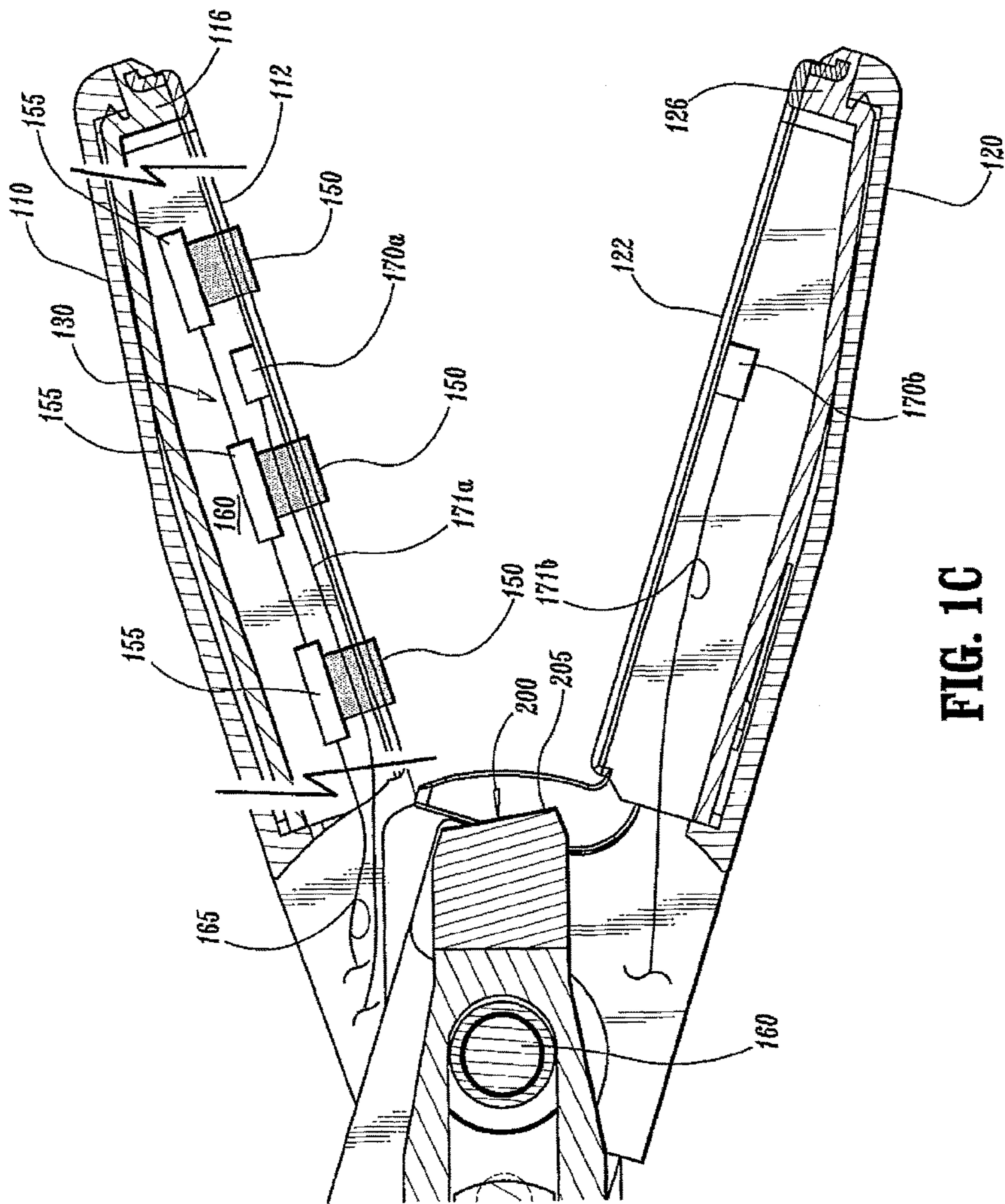

FIG. 1C

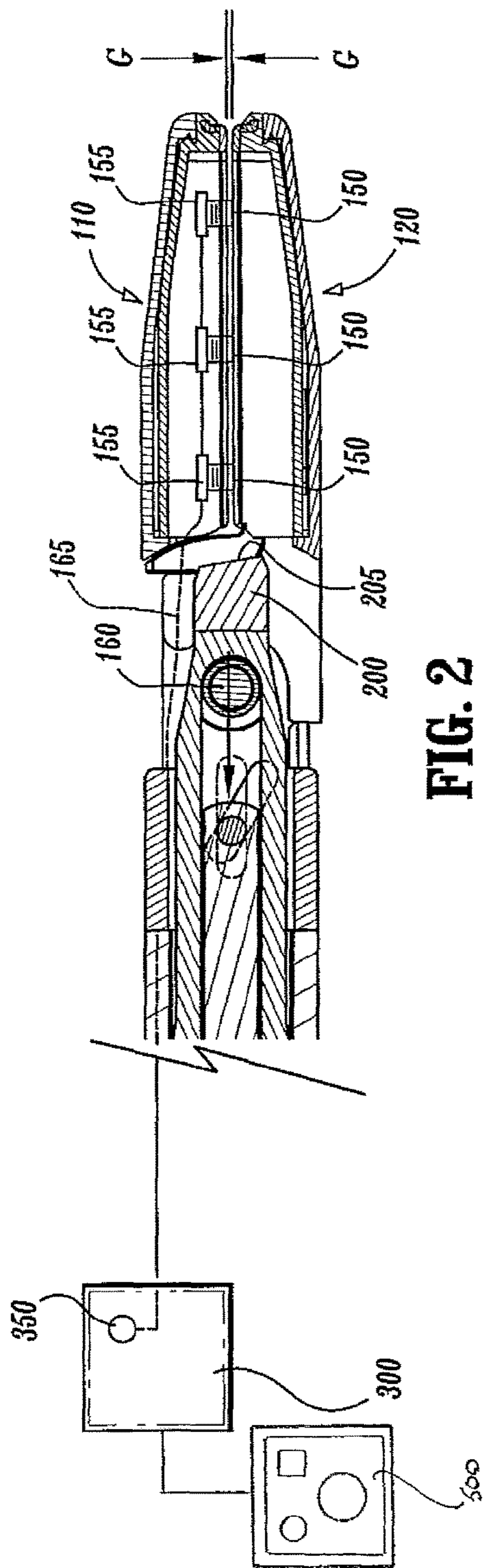

FIG. 2

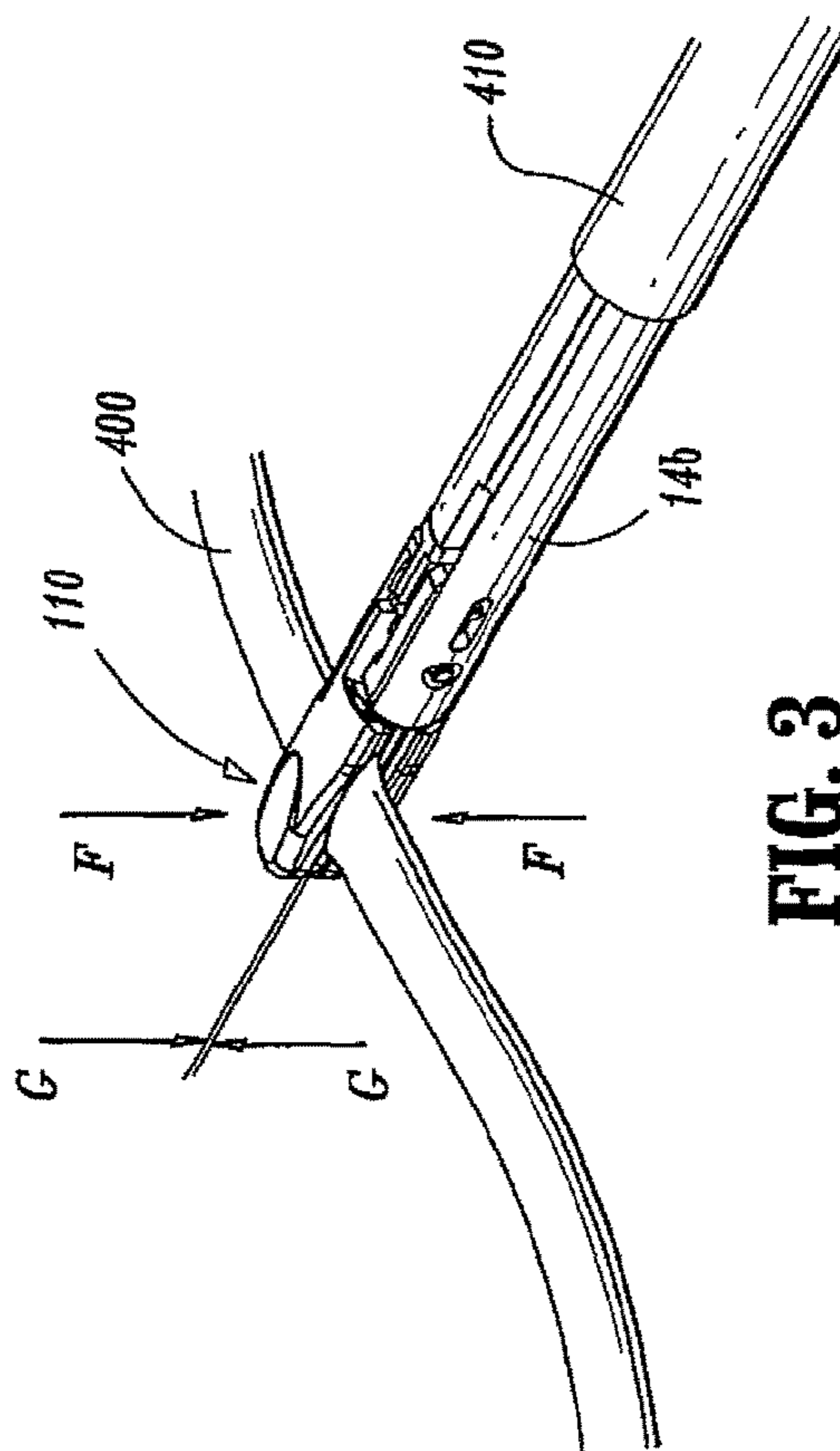

FIG. 3

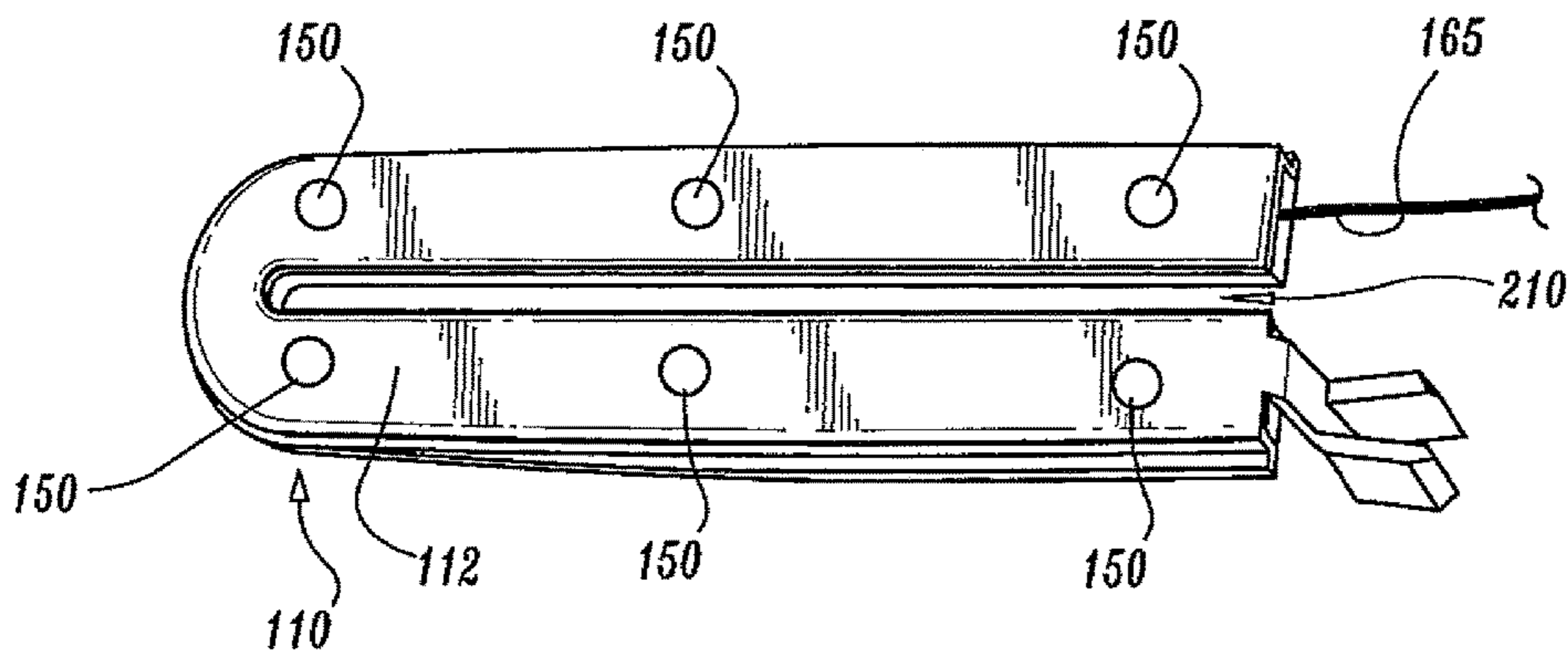

FIG. 4

**TISSUE SEALER WITH NON-CONDUCTIVE
VARIABLE STOP MEMBERS AND METHOD
OF SEALING TISSUE**

Matter enclosed in heavy brackets [] appears in the original patent but forms no part of this reissue specification; matter printed in italics indicates the additions made by reissue; a claim printed with strikethrough indicates that the claim was canceled, disclaimed, or held invalid by a prior post-patent action or proceeding.

CROSS-REFERENCE TO RELATED
APPLICATION

The present application is a continuation application of U.S. Ser. No. 10/846,262 now U.S. Pat. No. 7,491,201 filed by Shields et al. on May 14, 2004, which claims the benefit of priority to U.S. Provisional Application Ser. No. 60/470,632 filed on May 15, 2003 by Shields et al., both of which are incorporated by reference herein.

BACKGROUND

The present disclosure relates to an electrosurgical instrument and method for performing electrosurgical procedures. More particularly, the present disclosure relates to an open or endoscopic bipolar electrosurgical forceps and method of using same which includes a selectively-variable, non-conductive stop member associated with one or both of the opposing jaw members. The selectively-variable, non-conductive stop member is designed to control the gap distance between opposing jaw members and enhance the manipulation and gripping of tissue during the sealing process.

TECHNICAL FIELD

Forceps utilize mechanical action to constrict, grasp, dissect and/or clamp tissue. Electrosurgical forceps utilize both mechanical clamping action and electrical energy to effect hemostasis by heating the tissue and blood vessels. By controlling the intensity, frequency and duration of the electrosurgical energy applied through the jaw members to the tissue, the surgeon can coagulate, cauterize and/or seal tissue.

In order to effect a proper seal with larger vessels or thick tissue, two predominant mechanical parameters must be accurately controlled: the pressure applied to the tissue; and the gap distance between the electrodes. As can be appreciated, both of these parameters are affected by the thickness of vessels or tissue. More particularly, accurate application of pressure is important for several reasons: to reduce the tissue impedance to a low enough value that allows enough electrosurgical energy through the tissue; to overcome the forces of expansion during tissue heating; and to contribute to the end tissue thickness which is an indication of a good seal. It has been determined that fused tissue is optimum between about 0.001 inches to about 0.006 inches for small vessels and tissues and about 0.004 inches to about 0.008 inches for large, soft tissue structures. Below these ranges, the seal may shred or tear and above this range the tissue may not be properly or effectively sealed.

It is thought that the process of coagulating or cauterizing small vessels is fundamentally different than electrosurgical vessel or tissue sealing. "Vessel sealing" or "tissue sealing" is defined as the process of liquefying the collagen, elastin and ground substances in the tissue so that it reforms into a

fused mass with significantly-reduced demarcation between the opposing tissue structures. In contrast, the term "cauterization" is defined as the use of heat to destroy tissue (also called "diathermy" or "electrodiathermy") and the term "coagulation" is defined as a process of desiccating tissue wherein the tissue cells are ruptured and dried. Coagulation of small vessels is usually sufficient to permanently close them, however, larger vessels or tissue need to be "sealed" to assure permanent closure.

Numerous electrosurgical instruments have been proposed in the past for various open and endoscopic surgical procedures. However, most of these instruments cauterize or coagulate tissue and are normally not designed to provide uniformly reproducible pressure on the blood vessel or tissue which, if used for sealing purposes, would result in an ineffective or non-uniform seal. For example, U.S. Pat. No. 2,176,479 to Willis, U.S. Pat. Nos. 4,005,714 and 4,031,898 to Hildebrandt, U.S. Pat. Nos. 5,827,274, 5,290,287 and 5,312,433 to Boebel et al., U.S. Pat. Nos. 4,370,980, 4,552,143, 5,026,370 and 5,116,332 to Lottick, U.S. Pat. No. 5,443,463 to Stern et al., U.S. Pat. No. 5,484,436 to Eggers et al. and U.S. Pat. No. 5,951,549 to Richardson et al., all relate to electrosurgical instruments for coagulating, cauterizing, and cutting vessels or tissue.

Many of these instruments include blade members or shearing members which simply cut tissue in a mechanical and/or electromechanical manner and are relatively ineffective for vessel or tissue sealing purposes. Other instruments generally rely on clamping pressure alone to procure proper sealing thickness and are often not designed to take into account gap tolerances and/or parallelism and flatness requirements which are parameters which, if properly controlled, can assure a consistent and effective tissue seal. For example, it is known that it is difficult to adequately control thickness of the resulting sealed tissue by controlling clamping pressure alone for either of two reasons: 1) if too much force is applied, there is a possibility that the two poles will touch and energy will not be transferred through the tissue resulting in an ineffective seal; or 2) if too low a force is applied, a thicker less reliable seal is created.

Thus, a need exists to develop an electrosurgical instrument which effectively and consistently seals tissue and solves the aforementioned problems. This instrument should be designed to regulate the gap distances between opposing jaws members to procure a consistent and effective seal. The instrument may also be designed to reduce the chances of the opposing jaws short circuiting during activation and assist in manipulating, gripping and holding the tissue prior to and during electrosurgical activation.

SUMMARY

According to one embodiment of the present disclosure, a bipolar forceps for sealing tissue is disclosed. The forceps includes an elongated shaft having opposing jaw members at a distal end thereof each of the jaw members including an electrically conductive sealing surface affixed thereto. The jaw members are movable relative to one another from a first position wherein the electrically conductive sealing surfaces are disposed in spaced relation relative to one another to a second position wherein the electrically conductive sealing surfaces are moved closer to one another for grasping tissue and maintained at a distance relative to one another. Each electrically conductive sealing surface is adapted to be connected to a source of electrical energy such that the electrically conductive sealing surfaces are capable of conducting energy through tissue grasped therebetween to effect

a tissue seal. The distance between the electrically conductive sealing surfaces is selectively adjustable based upon a sensed pre-surgical condition during activation.

A method of sealing tissue is also contemplated by the present disclosure. The method includes an initial step of providing a bipolar forceps including a shaft having opposing jaw members at a distal end thereof which cooperate to grasp tissue therebetween, each of the jaw members including an electrically conductive sealing surface connected to a source of electrosurgical energy. The method also includes the steps of: adjusting a distance between the electrically conductive sealing surface based upon a sensed pre-surgical condition during activation, actuating the jaw members to grasp tissue between opposing jaw members, and conducting energy to the jaw members through tissue held therebetween to effect a tissue seal.

Another method of sealing tissue is also contemplated by the present disclosure. The method includes an initial step of providing a bipolar forceps including a shaft having opposing jaw members at a distal end thereof which cooperate to grasp tissue therebetween, each of the jaw members including an electrically conductive sealing surface connected to a source of electrosurgical energy. The method also includes the steps of actuating the jaw members to grasp tissue between opposing jaw members, conducting energy to the jaw members through tissue held therebetween to effect a tissue seal and adjusting a distance between the electrically conductive sealing surface based upon a sensed surgical condition during activation.

A further method of sealing tissue is contemplated by the present disclosure. The method includes an initial step of providing a bipolar forceps which includes a shaft having opposing jaw members at a distal end thereof each of the jaw members including an electrically conductive sealing surface, at least one of the electrically conductive sealing surfaces connected to a source of electrosurgical energy. The method also includes the steps of: actuating the jaw members to grasp tissue between opposing jaw members, wherein the jaw members are disposed at a distance relative to one another, adjusting the distance between the jaw members during the conducting step based upon a sensed surgical condition during activation and conducting energy to the jaw members through tissue held therebetween.

BRIEF DESCRIPTION OF THE DRAWINGS

Various embodiments of the present disclosure are described herein with reference to the drawings wherein:

FIG. 1A is a perspective view of an endoscopic bipolar forceps which is configured to support a variable stop member assembly according to the present disclosure;

FIG. 1B is a side, partial internal view of an endoscopic forceps showing a selectively adjustable stop member assembly according to the present disclosure;

FIG. 1C is an enlarged view of the area of detail of FIG. 1B;

FIG. 2 is a side, partial internal view of an end effector assembly shown in closed configuration;

FIG. 3 is a rear, perspective view of the end effector of FIG. 2 shown with tissue grasped therein; and

FIG. 4 is an enlarged, perspective view of an electrically conductive sealing surface of the end effector assembly showing a series of selectively adjustable stop members disposed thereon.

DETAILED DESCRIPTION

Referring now to FIGS. 1A-4, an endoscopic bipolar forceps **10** is shown by way of example for use with various

endoscopic surgical procedures. Either an endoscopic instrument or an open instrument may be utilized for supporting the variable stop member assembly according to the present disclosure. Obviously, different electrical and mechanical connections and considerations apply to each particular type of instrument, however, the novel aspects with respect to the stop member assembly and its operating characteristics remain generally consistent with respect to both the open or endoscopic designs. Forceps **10** is shown by way of example and other electrosurgical forceps are also envisioned which may support the stop member assembly of the present disclosure. In the drawings and in the description which follows, the term "proximal", as is traditional, will refer to the end of the forceps **10** which is closer to the user, while the term "distal" will refer to the end of the forceps which is further from the user.

FIGS. 1A-1C show an endoscopic vessel sealing forceps **10** which is configured to support an electrode sealing assembly **100**. More particularly, forceps **10** generally includes a housing **20**, a handle assembly **30**, a rotating assembly **80**, a trigger assembly **70** and the end effector assembly **100** which mutually cooperate to grasp, seal and, if warranted, divide tissue. The forceps **10** includes a shaft **12** which has a distal end **14** dimensioned to mechanically engage the end effector assembly **100** and a proximal end **16** which mechanically engages the housing **20** proximate the rotating assembly **80**.

Forceps **10** also includes a plug (not shown) which connects the forceps **10** to a source of electrosurgical energy, e.g., an electrosurgical generator **500**, via an electrical cable **310**. Handle assembly **30** includes a fixed handle **50** and a movable handle **40**. Handle **40** moves relative to fixed handle **50** to actuate the end effector assembly **100** and enable a user to grasp and manipulate tissue **400** (See FIG. 3). The end effector assembly **100** includes a pair of opposing jaw members **110** and **120** which each have an electrically conductive sealing surface **112** and **122**, respectively, attached thereto for conducting electrosurgical energy through tissue **400** held therebetween. More particularly, the jaw members **110** and **120** move in response to movement of the handle **40** from an open position wherein the electrically conductive sealing surfaces **112** and **122** are disposed in spaced relation relative to one another, to a clamping or closed position wherein the electrically conductive sealing surfaces **112** and **122** cooperate to grasp tissue therebetween.

The housing **20** encloses a drive assembly (not shown) which cooperates with the movable handle **40** to impart movement of the jaw members **110** and **120** from the open position to the clamping or closed position. One Example of a handle assembly is shown and described in commonly-owned U.S. application Ser. No. 10/389,894 entitled "VESSEL SEALER AND DIVIDER AND METHOD MANUFACTURING SAME" which is hereby incorporated by reference herein in its entirety. The handle assembly of this particular disclosure is generally be characterized as a four-bar mechanical linkage which provides a unique mechanical advantage when sealing tissue between the jaw members **110** and **120**. For example, once the desired position for the sealing site is determined and the jaw members **110** and **120** are properly positioned, handle **40** may be compressed fully to lock the electrically conductive sealing surfaces **112** and **122** in a closed position against the tissue. The details relating to the inter-cooperative relationships of the inner-working components of forceps **10** are disclosed in the above-cited commonly-owned U.S. patent application Ser. No. 10/369,894. When the electrically conductive sealing surfaces **112** and **122** of the jaw members

110 and **120** are fully compressed about the tissue **400**, the forceps **10** is now ready for selective application of electro-surgical energy (See FIG. 3). Another example of an endoscopic handle assembly is disclosed in U.S. patent application Ser. No. 10/460,926 entitled "VESSEL SEALER AND DIVIDER FOR USE WITH SMALL TROCARS AND CANNULAS", the entire contents of this application being incorporated by reference herein.

Experimental results suggest that the magnitude of pressure exerted on the tissue **400** by the electrically conductive sealing surfaces **112** and **122** is important in assuring a proper surgical seal. Pressures within a working range of about 3 kg/cm² to about 16 kg/cm² and, in embodiments, within a working range of about 7 kg/cm² to about 13 kg/cm² have been shown to be effective for sealing various small tissue types. Pressure within a working range of about 4.5 kg/cm² to about 8.5 kg/cm² are optimal for large soft tissue structures.

As explained above, movement of the handle assembly **30**, e.g., via a four-bar linkage, ultimately causes the opposing jaw members **110** and **120** to move relative to one another. As can be appreciated, the significant mechanical advantage associated with the four-bar linkage permits facile, consistent and uniform compression of the jaw members **110** and **120** about the tissue **400**. Other details and advantages of the four-bar mechanical linkage are more fully discussed with respect to the above-mentioned commonly-owned U.S. patent application Ser. No. 10/369,894.

As best seen in FIGS. 1A-1C, forceps **10** also includes a trigger **70** which advances a knife **200** disposed within the end effector assembly **100**. Once a tissue seal is formed, the user can activate the trigger **70** to separate the tissue **400** along the tissue seal. Knife **200** includes a sharpened edge **205** for severing the tissue **400** held between the jaw members **110** and **120** at the tissue sealing site.

A rotating assembly **80** may also be incorporated with forceps **10**. In embodiments, rotating assembly **80** is mechanically associated with the shaft **12** and the drive assembly (not shown). Movement of the rotating assembly **80** imparts similar rotational movement to the shaft **12** which, in turn, rotates the end effector assembly **100**. These features along with the unique electrical configuration for the transference of electro-surgical energy through the handle assembly **20** and the rotating assembly **80** are described in more detail in the above-mentioned commonly-owned U.S. patent application Ser. Nos. 10/369,894 and 10/460,926.

As best seen with respect to FIGS. 1A-2, end effector assembly **100** attaches to the distal end **14** of shaft **12**. The jaw members **110** and **120** are pivotable about a pivot **160** from the open to closed positions upon relative reciprocation, i.e., longitudinal movement, of the drive assembly (not shown). Again, mechanical and cooperative relationships with respect to the various moving elements of the end effector assembly **100** are further described by example with respect to the above-mentioned commonly-owned U.S. patent application Ser. Nos. 10/369,894 and 10/460,926.

It is envisioned that the forceps **10** may be designed such that it is fully or partially disposable depending upon a particular purpose or to achieve a particular result. For example, end effector assembly **100** may be selectively and releasably engageable with the distal end **14** of the shaft **12** and/or the proximal end **16** of the shaft **12** may be selectively and releasably engageable with the housing **20** and handle assembly **30**. In either of these two instances, the forceps **10** would be considered "partially disposable" or "reposable", i.e., a new or different end effector assembly **100** (or end

effector assembly **100** and shaft **12**) selectively replaces the old end effector assembly **100** as needed.

Each of the jaw members **110** and **120** includes an electrically conductive sealing surface **112** and **122**, respectively disposed on an inner-facing surface thereof. It is envisioned that the electrically conductive surfaces **112** and **122** cooperate to seal tissue **400** held therebetween upon the application of electro-surgical energy. Insulators **116** and **126** (together with the outer, non-conductive surfaces of the jaw members **110** and **120**) may be included to limit and/or reduce many of the known undesirable effects related to tissue sealing, e.g., flashover, thermal spread and stray current dissipation (See FIG. 1C).

In embodiments, a least one of the electrically conductive surfaces, e.g., **112**, of one of the jaw members, e.g., **110**, includes a longitudinally-oriented channel **210** defined therein (See FIG. 4) which extends from the proximal end of the electrically conductive sealing surface **112** to the distal end. The channel **210** facilitates longitudinal reciprocation of the knife **200** along a desired cutting plane to effectively and accurately separate the tissue **400** along a formed tissue seal.

By controlling the intensity, frequency and duration of the electro-surgical energy applied to the tissue **400**, the user can selectively seal tissue **400**. As mentioned above, two mechanical factors play an important role in determining the resulting thickness of the sealed tissue and effectiveness of the seal, i.e., the pressure applied between opposing jaw members **110** and **120** and the gap distance "G" between the opposing sealing surfaces **112** and **122** of the jaw members **110** and **120**, respectively, during the sealing process.

However, thickness of the resulting tissue seal cannot be adequately controlled by force alone. In other words, too much force and the two jaw members **110** and **120** would touch and possibly short resulting in little energy traveling through the tissue **400** thus resulting in a bad tissue seal. Too little force and the seal would be too thick. Applying the correct force is also important for other reasons: to reduce the tissue impedance to a low enough value that allows enough current through the tissue **400**; and to overcome the forces of expansion during tissue heating in addition to contributing towards creating the required end tissue thickness which is an indication of a good seal.

In order to achieve a desired spacing between the electrically conductive surfaces **112** and **122** of the respective jaw members **110** and **120**, (i.e., gap distance "G") and apply a desired force to seal the tissue **400**, at least one jaw member **110** and/or **120** includes at least one stop member, e.g., **150**, to limit the movement of the two opposing jaw members **110** and **120** relative to one another. In one embodiment, the stop member, e.g., **150**, extends from at least one of the sealing surfaces **112**, **122** a predetermined distance according to the specific material properties of the stop member **150** (e.g., compressive strength, thermal expansion, etc.) to yield a consistent and accurate gap distance "G" during sealing. In one embodiment, the gap distance "G" between opposing sealing surfaces **112** and **122** during sealing ranges from about 0.001 inches to about 0.008 inches. For smaller tissue types the gap distance may be between about 0.002 inches to about 0.003 inches and for larger tissue types the gap distance may be between about 0.004 inches to about 0.007 inches.

In embodiments, stop members **150** are made from an insulative material, e.g., parylene, nylon and/or ceramic and are dimensioned to limit opposing movement of the electrically conductive sealing surfaces **112** and **122** to within the above mentioned gap range "G". It is envisioned that the

stop members **150** may be disposed on one or both of the electrically conductive sealing surfaces **112** and **122** depending upon a particular purpose or to achieve a particular result.

As best shown in FIGS. **1B** and **1C**, at least of the jaw members includes a selectively adjustable stop member assembly **140** which allows a surgeon to regulate the gap distance "G" depending upon a particular tissue type and/or tissue thickness. More particularly, at least one of the jaw members, e.g., jaw member **110**, includes a cavity **130** disposed therein which is dimensioned to house the stop member assembly **140**. Stop member assembly **140** includes a plurality of selectively adjustable stop member control units **145** which includes a stop member **150** and a controller **155**. More particularly, the controller **155** is designed to receive signals from a control source **300** (FIG. **2**) which may be attached to an electrosurgical generator **500** or incorporated into the housing of the forceps **10**. The control source **300** signals the controller **155** to electrically, mechanically or electro-mechanically adjust the distance the stop member(s) **150** projects or extends from the electrically conductive sealing surface **112** (and/or **122**). The distance that the stop member(s) **150** projects from the electrically conductive sealing surface **112** (and/or **122**) determines the ultimate gap distance "G" (See FIG. **2**).

It is envisioned that the controller **155** may adjust the distance that each stop member **150** extends from the sealing surface **112** in any known fashion. For example, each stop member **150** and its corresponding controller **155** may be threadably connected such that the controller **155** "unscrews" the stop member **150** to adjust the distance that the stop member **150** extends from the sealing surface **112**. Thus, by controlling the amount that the stop member **150** unscrews from the controller **155**, a surgeon can selectively regulate (or a control source **300** may automatically regulate) the gap distance "G". Other mechanical systems (not shown) are also envisioned to allow selective regulation of the gap distance "G", e.g., gearing mechanisms, camming mechanisms, pneumatic mechanisms, hydraulic mechanisms, etc. Electromechanical systems are also contemplated, e.g., electro-mechanical actuators, ferroelectric actuators, piezo-electric actuators, piezo-ceramic actuators, magnetostrictors and rotational actuators, etc.

It is envisioned that the controller **155** may cooperate with a sensor assembly **170a** and **170b** (or a plurality of sensors) which determines or measures tissue thickness, tissue moisture, tissue type, tissue impedance, etc. and automatically signals the control source **300** to signal the controller **155** to adjust the stop members **150** to extend a specific distance (i.e., a "desired" gap distance "G") from the electrically conductive sealing surface **112** prior to activation. The desired gap distance "G" (which directly corresponds to the specified distance that the stop members **150** extend from the electrically conductive sealing surface **112**) may be selected from a look-up table or determined by a computer algorithm stored within the control source **300**. It is envisioned that the stop members are selectively adjustable to protrude about 0.001 inches to about 0.008 inches from the electrically conductive sealing surfaces **112** (and/or **122**) of the jaw members **110** (and/or **120**).

It is also contemplated that one or more stop members **150** may be individually controllable (via controller **155** or manually) to vary the gap distance along or across the sealing surfaces depending upon a particular purpose or to achieve a particular tissue seal. Moreover, it is envisioned that varying the distance that stop member(s) project from the sealing surface(s) may produce different results for

different tissue types and may prove desirable for one or more particular tissue types or one or more different surgical procedures.

The sensors **170a** and **170b** are connected to the control source **300** (or electrosurgical generator) via cables **171a** and **171b**, respectively. The sensors **170a** and **170b** may form a part of a closed-loop control system which automatically adjusts the forceps **10** prior to and/or during activation based on pre-surgical parameters and continually-sensed parameters. For example, the stop members **150** may be adjusted based upon a pre-surgical parameter such as tissue thickness, tissue type, tissue compliance, tissue impedance, etc. One example of a closed-loop control system is described in commonly-owned U.S. patent application Ser. No. 10/427,832 filed on May 1, 2003 entitled "METHOD AND SYSTEM FOR CONTROLLING OUTPUT OF RF MEDICAL GENERATOR" the entire contents of which are hereby incorporated by reference herein. For example, the stop member(s) **150** may be set according to a pre-surgical condition (either automatically based upon a sensed condition (e.g., tissue impedance, tissue type, tissue clarity, tissue compliance, etc.)) or manually by the surgeon.

It is also envisioned that the stop member(s) **150** may be adjusted during activation based upon a continually-sensed surgical condition (e.g., tissue impedance, tissue type, tissue clarity, tissue compliance, etc.) utilizing a feed back control loop. It is envisioned that this may allow the control system to achieve a "slow close" condition. More particularly, one technique for sealing larger tissue structures (e.g., lung, liver, bronchus, etc.) is a so-called "slow-close" surgical technique which involves activating the surgical instrument prior to obtaining a fully ratcheted position. As can be appreciated, this type of procedure is very difficult to master manually due to the many variables involved with the sealing process and, as a result, the instrument may short or the sealing cycle may complete prior to obtaining the fully closed ratcheted position. It is envisioned that the automatic stop member adjustment system described above may enable slow close activation which may lead to more effective sealing of large tissue structures. For example, the surgeon can grasp the tissue in a customary manner and fully ratchet the forceps about the tissue within the desired pressure ranges. The stop member(s) **150** can be programmed to activate in a "slow close" manner and automatically adjust from a large gap distance e.g., about 0.10 inches to within a gap range of about 0.001 inches to about 0.008 inches during activation. The stop member control assembly **140** may also be coupled to a feedback control system which automatically regulates the "slow close" technique based upon tissue thickness, tissue temperature, tissue impedance, tissue moisture, tissue clarity, tissue compliance during activation. As can be appreciated, this enables any surgeon to perform a slow close technique for sealing larger tissue structures.

A control knob **350** (See FIG. **2**) may also be included to permit a surgeon to manually adjust the distance that the stop members **150** protrude from the electrically conductive sealing surface **112** (and/or **122**) depending upon a particular purpose.

FIG. **4** shows one contemplated configuration of the stop members **150** disposed on or protruding from the electrically conductive sealing surface **112**. It is envisioned that the stop members **150** can be positioned on either or both jaw members **110** and **120** depending upon a particular purpose or to achieve a desired result. More particularly and as illustrated in FIG. **4**, a series of longitudinally-oriented tab-like stop members **150** are disposed along either side of

the knife channel **210** of jaw member **110**. In embodiments, the stop members **150** may be configured in any known geometric or polynomial configuration, e.g., triangular, rectangular, circular, ovoid, scalloped, etc., depending upon a particular purpose. Moreover, it is contemplated that any combination of different stop members **150** may be assembled along the sealing surfaces **112** (and/or **122**) to achieve a desired gap distance "G". A ceramic or insulative coating may be deposited or sprayed onto the tissue engaging surface of the stop members **150**. Thermal spraying techniques are contemplated which involve depositing a broad range of heat resistant and insulative materials on the tissue engaging surfaces of the stop members **150**, high velocity Oxy-fuel deposition, plasma deposition, etc.

Further, although it is the stop members **150** may be selectively adjustable to protrude about 0.001 inches to about 0.008 inches from the electrically conductive sealing surfaces **112**, in some cases the stop members **150** may protrude more or less depending upon a particular purpose. For example, it is contemplated that the type of material used for the stop members **150** and that material's ability to absorb the desired range of compressive closure forces between jaw members **110** and **120** will vary and, therefore, the overall distance that the stop members **150** may have to extend from the electrically conductive sealing surfaces **112** may have to be adjusted to compensate for the particular stop member **150** material being utilized to produce the desired gap distance "G".

In other words, the compressive strength of the stop member material along with the desired or ultimate gap distance "G" required for effective sealing are parameters which should be considered during activation since one material may have to be adjusted differently from another material to achieve the same gap distance "G". For example, the compressive strength of nylon is different from ceramic and, therefore, the nylon material may have to extend a greater distance from the electrically conductive sealing surface **112** to counteract the closing force of the opposing jaw members **110** and **120** and to achieve the same desired gap distance "G". As can be appreciated, these considerations may be automatically regulated or controlled at the control source **300** via a computer algorithm or look up table.

The present disclosure also relates to a method of sealing tissue utilizing a selectively adjustable stop member **150** and includes the steps of: providing a bipolar forceps **10** having a shaft **12** and opposing jaw members **110** and **120** which cooperate to grasp tissue **400** therebetween; at least one selectively extendible and non-conductive stop member **150** disposed on an electrically conductive surface **112** of at least one of the jaw members, e.g., **110**, which regulates the distance between the jaw members **110** and **120** when tissue **400** is held therebetween. The method further includes the steps of: connecting the electrically conductive sealing surfaces **112** and **122** of the jaw members **110** and **120** to a source of electrosurgical energy; adjusting the distance that the stop members **150** extend from the electrically conductive sealing surface **112** depending upon a pre-surgical condition or parameter; actuating the jaw members **110** and **120** to grasp tissue **400** between opposing electrically conductive sealing surfaces **112** and **122**; conducting energy to the electrically conductive sealing surfaces **112** and **122** through tissue **400** held therebetween to effect a seal.

The adjusting step of the method may further include the steps of: sensing a pre-surgical condition or parameter such as tissue type, tissue thickness, tissue compliance, tissue impedance, etc. and signaling the controller **155** (via the

control source **300** or directly) to selectively extend or retract the stop members **150** relative to the electrically conductive sealing surface **112** depending upon the sensed pre-surgical condition or parameter.

At least one of the jaw members, e.g., **110**, of the providing step includes may include an electrically conductive sealing surface **112** having a longitudinally-oriented channel **210** defined therein which facilitates actuation of a knife **200** in a longitudinally reciprocating fashion within the channel **210** for severing the tissue **400** proximate the tissue sealing site. As can be appreciated, the method may also include the step of severing the tissue **400** along the tissue seal.

From the foregoing and with reference to the various figure drawings, those skilled in the art will appreciate that certain modifications can also be made to the present disclosure without departing from the scope of the same. For example, it may be desirable to add other features to the forceps **10**, e.g., an articulating assembly to axially displace the end effector assembly **100** relative to the elongated shaft **12**.

Moreover, it is contemplated that the presently disclosed forceps may include a disposable end effector assembly **100** which is selectively engageable with at least one portion of the electrosurgical instrument, e.g., shaft **12** and/or handle assembly **80**. In one embodiment, the electrically conductive sealing surfaces **112** and **122** of the jaw members **110** and **120** are relatively flat to avoid current concentrations at sharp edges and to avoid arcing between high points. In addition and due to the reaction force of the tissue **400** when engaged, jaw members **110** and **120** may be manufactured to resist bending. For example, the jaw members **110** and **120** may be tapered along their respective widths which is advantageous for two reasons: 1) the taper will apply constant pressure for a constant tissue thickness at parallel; 2) the thicker proximal portion of the jaw members **110** and **120** will resist bending due to the reaction force of the tissue **400**.

It is also contemplated that one or more stop members may be disposed adjacent to one or both electrically conductive sealing surfaces to regulate the gap distance between conductive surfaces. Alternatively, one or more selectively extendible stop members may be disposed on one or both electrically conductive sealing surface(s) and one or more stop members may be disposed adjacent to at least one of the electrically conductive surfaces. As can be appreciated, both sets of selectively adjustable stop members would cooperate with the controller (or manually) to adjust and regulate the gap distance.

The stop member(s) may be dimensioned in any known geometric configuration and may be disposed on or adjacent to one or both of the electrically conductive tissue sealing surfaces or operatively associated with one or both jaw members. Moreover, the controller and stop member may be integrally associated with one another or may be formed from two or more components so long as the stop member is selectively adjustable to regulate the distance between the jaw members prior to and/or during electrical activation.

While several embodiments of the disclosure have been shown in the drawings and/or discussed herein, it is not intended that the disclosure be limited thereto, as it is intended that the disclosure be as broad in scope as the art will allow and that the specification be read likewise. Therefore, the above description should not be construed as limiting, but merely as exemplifications of particular

11

embodiments. Those skilled in the art will envision other modifications within the scope and spirit of the claims appended hereto.

What is claimed is:

1. A bipolar forceps for sealing tissue, comprising:
an elongated shaft having opposing jaw members at a distal end thereof, each of the jaw members including an electrically conductive sealing surface affixed thereto, at least one of the jaw members movable relative to the other jaw member from a first position wherein the electrically conductive sealing surfaces are disposed in spaced relation relative to one another to a second position wherein the electrically conductive sealing surfaces are moved closer to one another for grasping tissue[.]; each electrically conductive sealing surface adapted to connect to a source of electrical energy such that the electrically conductive sealing surfaces are capable of conducting energy through tissue grasped therebetween to effect a tissue seal[, wherein]; *and*
a stop member extending from one of the electrical conductive sealing surfaces, the stop member adjustable during activation to regulate the distance between the electrically conductive sealing surfaces [is automatically adjustable] in response to a sensed pre-surgical condition during activation.
2. A bipolar forceps for sealing tissue according to claim 1, further including at least one controller engagable with at least one of the electrically conductive sealing surfaces, the controller configured to *adjust the stop member* to control the distance between the electrically conductive sealing surfaces in response to a signal from a control source.
3. A bipolar forceps for sealing tissue according to claim 2, wherein the bipolar forceps includes at least one sensor disposed on at least one of the jaw members, the at least one sensor configured to sense the sensed pre-surgical condition selected from the group consisting of tissue impedance, tissue thickness, tissue compliance, and tissue type, and further configured to relay the sensed information to a control source which, in turn, is configured to send a signal to the *at least one* controller.
4. A bipolar forceps for sealing tissue according to claim 1, wherein the forceps includes a selectively extendible knife for severing tissue along the tissue seal.
5. A bipolar forceps for sealing tissue according to claim 1, wherein the electrically conductive sealing surfaces are adjusted a distance in the range of about 0.001 inches to about 0.008 inches relative to one another.
6. A method of sealing tissue comprising [the steps of]:
providing a bipolar forceps including a shaft having opposing jaw members at a distal end thereof which cooperate to grasp tissue therebetween, each of the jaw members including an electrically conductive sealing surface [connected] *affixed thereto and adapted to connect* to a source of electrosurgical energy;
[automatically adjusting a distance between the electrically conductive sealing surface in response to a sensed pre-surgical condition during activation;]
actuating the jaw members to grasp tissue between opposing jaw members; [and]
conducting energy to the jaw members through tissue grasped therebetween to effect a tissue seal; *and*

12

adjusting a stop member extending from one of the electrically conductive sealing surfaces to regulate a distance between the electrically conductive sealing surfaces in response to a sensed pre-surgical condition while energy is conducted to the jaw members.

7. A method of sealing tissue according to claim 6, wherein the adjusting [step] *the stop member* further includes [the steps of]:
sensing the sensed pre-surgical condition; and
signaling a controller to selectively adjust *the stop member such that* the distance between the electrically conductive sealing surfaces depending upon the sensed pre-surgical condition.
8. A method of sealing tissue according to claim 6, further comprising the step of severing the tissue along the tissue seal.
9. A method of sealing tissue according to claim 6, wherein after the conducting step, the method further includes the steps of:
sensing a tissue parameter during electrosurgical activation; and
signaling a controller to selectively adjust *the stop member such that* the distance between the electrically conductive sealing surfaces *is* based upon the sensed tissue parameter.
10. A method of sealing tissue according to claim 9, wherein after the [sensed] signaling step, the method further includes the step of repeating the sensing and signaling steps until a desired seal is effected.
- [11. A method of sealing tissue comprising the steps of:
providing a bipolar forceps including a shaft having opposing jaw members at a distal end thereof which cooperate to grasp tissue therebetween, each of the jaw members including an electrically conductive sealing surface connected to a source of electrosurgical energy; actuating the jaw members to grasp tissue between opposing jaw members, wherein the jaw members are disposed at a distance relative to one another; automatically adjusting the distance between the electrically conductive sealing surfaces in response to a sensed surgical condition during activation; and conducting energy to the jaw members through tissue grasped therebetween to effect a tissue seal.]
- [12. A method of sealing tissue according to claim 11, wherein the adjusting step further includes the step of communicating with a feedback control system that continually senses surgical conditions during activation to automatically regulate the distance between the electrically conductive sealing surfaces.]
- [13. A method of sealing tissue according to claim 11, wherein the adjusting step, further includes the step of communicating with a feedback control system to automatically regulate the distance between the electrically conductive sealing surfaces based upon at least one of tissue impedance, tissue temperature, tissue thickness, tissue moisture, tissue compliance or tissue clarity during activation.]
- [14. A method of sealing tissue according to claim 11, wherein the step of adjusting includes adjusting the distance between the electrically conductive sealing surfaces so that the distance between the electrically conductive sealing surfaces becomes increasingly smaller.]

* * * * *