

US00RE47284E

(19) **United States**
(12) **Reissued Patent**
Kim

(10) **Patent Number: US RE47,284 E**
(45) **Date of Reissued Patent: *Mar. 12, 2019**

(54) **REFRIGERATOR AND MANUFACTURING METHOD OF THE SAME**

(71) Applicant: **LG Electronics Inc.**, Seoul (KR)

(72) Inventor: **Pansoo Kim**, Seoul (KR)

(73) Assignee: **LG ELECTRONICS INC.**, Seoul (KR)

(*) Notice: This patent is subject to a terminal disclaimer.

(21) Appl. No.: **14/843,719**

(22) Filed: **Sep. 2, 2015**

Related U.S. Patent Documents

Reissue of:

(64) Patent No.: **8,523,304**
Issued: **Sep. 3, 2013**
Appl. No.: **12/863,050**
PCT Filed: **Dec. 17, 2008**
PCT No.: **PCT/KR2008/007498**
§ 371 (c)(1),
(2) Date: **Jul. 15, 2010**
PCT Pub. No.: **WO2009/104859**
PCT Pub. Date: **Aug. 27, 2009**

(30) **Foreign Application Priority Data**

Feb. 21, 2008 (KR) 10-2008-0015776

(51) **Int. Cl.**
A47B 96/04 (2006.01)
A47F 3/04 (2006.01)
(Continued)

(52) **U.S. Cl.**
CPC *A47F 3/04* (2013.01); *B23P 15/26* (2013.01); *F25D 29/005* (2013.01); *F25D 2400/361* (2013.01); *Y10T 29/49359* (2015.01)

(58) **Field of Classification Search**
CPC *A47F 3/04*; *B23P 15/26*; *Y10T 29/49359*; *F25D 29/005*; *F25D 2400/361*
See application file for complete search history.

(56) **References Cited**

U.S. PATENT DOCUMENTS

2,766,856 A * 10/1956 Nelsson 49/246
5,147,127 A * 9/1992 Honda G02F 1/133604
349/70

(Continued)

FOREIGN PATENT DOCUMENTS

CN 1940424 A 4/2007
CN 101099790 A 1/2008

(Continued)

OTHER PUBLICATIONS

English translation of JP 2002-039673, published Feb. 6, 2002.
English translation of KR10-20070034835.*

Primary Examiner — Stephen J. Ralis
(74) *Attorney, Agent, or Firm* — Birch, Stewart, Kolasch & Birch, LLP

(57) **ABSTRACT**

[The present embodiment provides a refrigerator. The refrigerator according to the present embodiment includes] *A refrigerator includes a cabinet having a storage space, a door opening and closing the storage space, the door including a panel member forming at least a portion of the exterior of the door of the refrigerator, an inner case of which at least portion is spaced from the panel, a deco member that connects the panel member and the inner case, a display case provided at one side of the panel member, insulating material filled in space between the panel member and the inner case, and a display unit mounted on the display case after the filling of the insulating material is completed. The display case may include a pressure part that pressurizes the display unit toward the panel member. A mounting guide may guide a location of a unit guide of the display unit.*

59 Claims, 5 Drawing Sheets

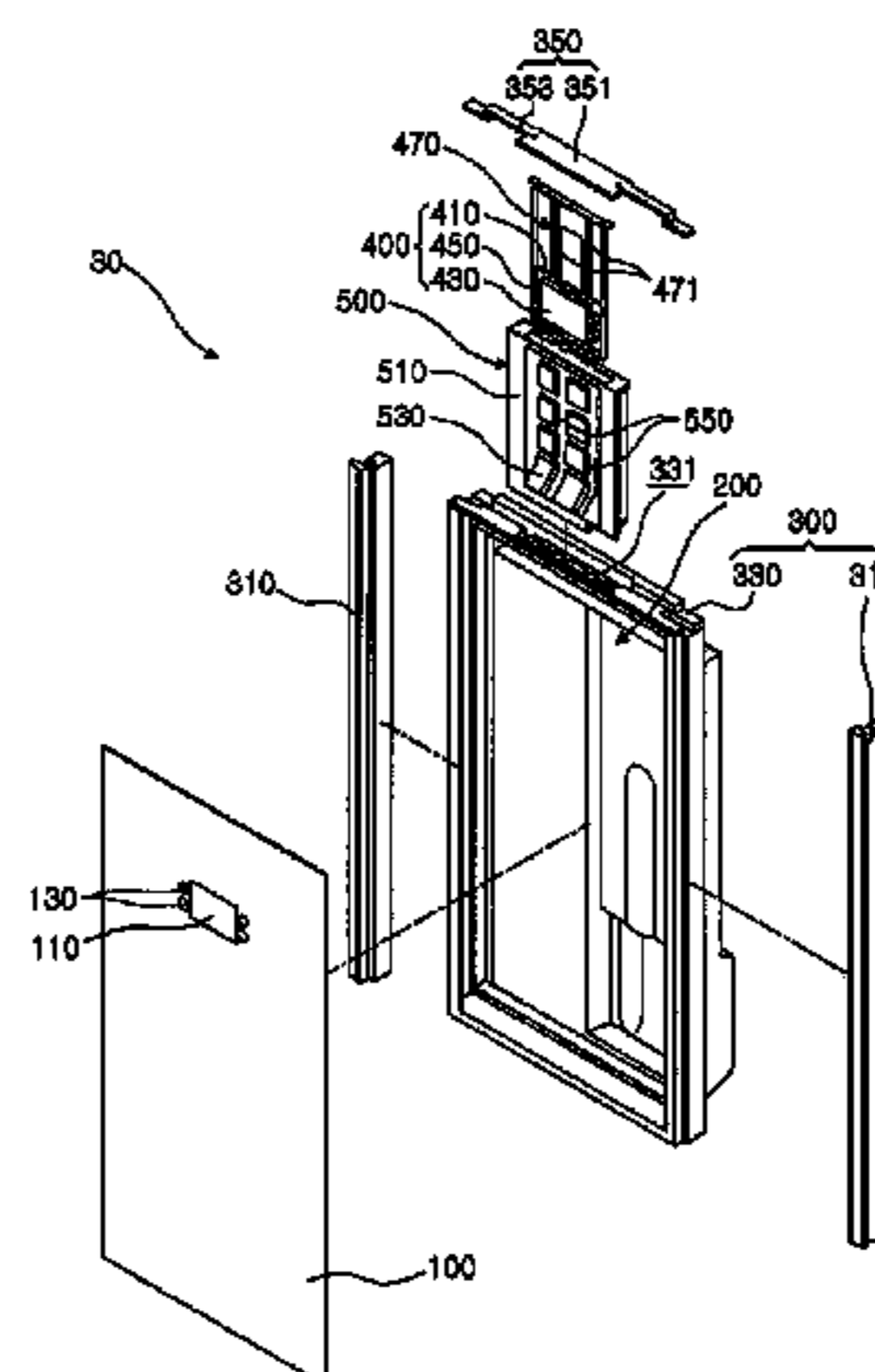
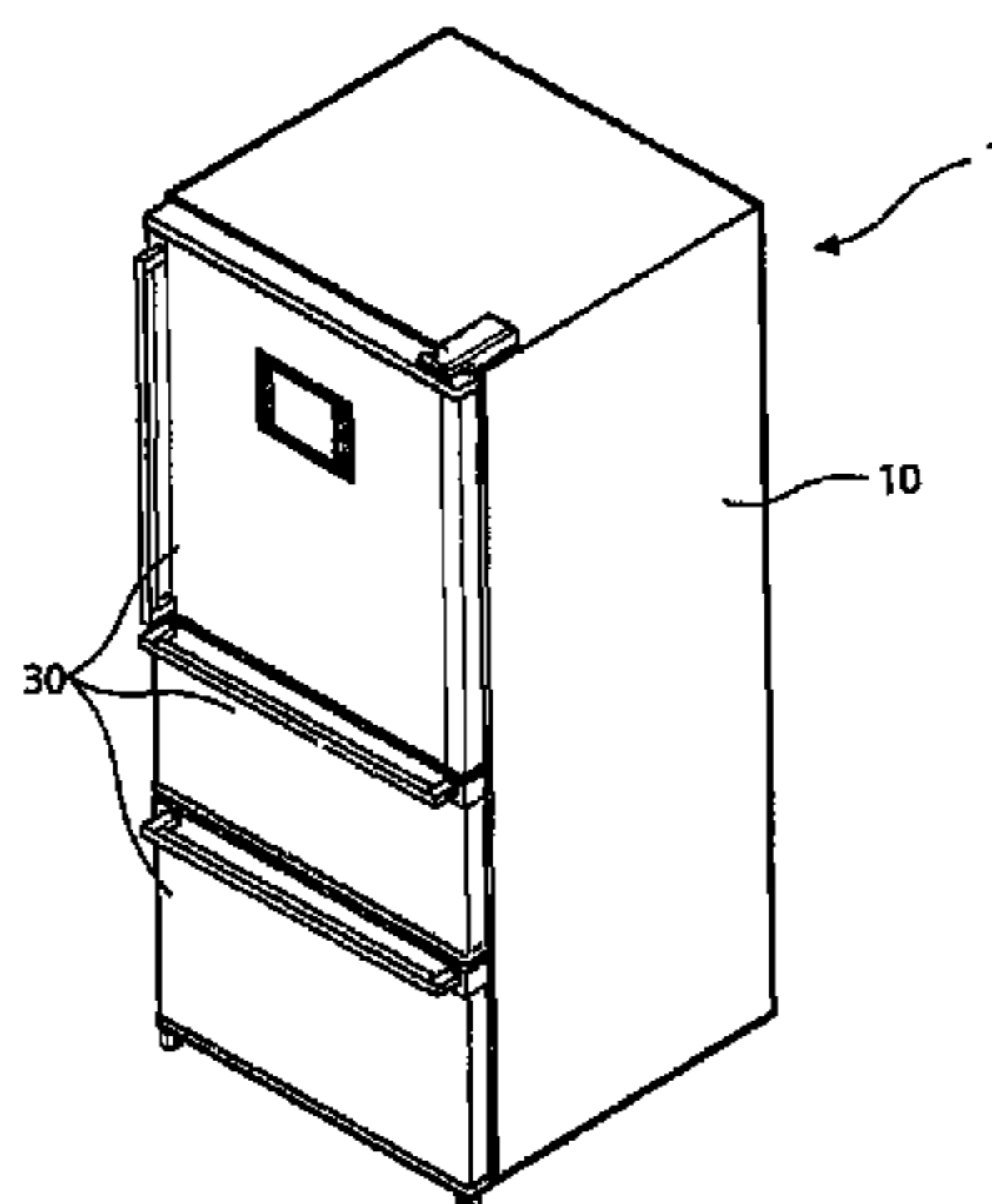

US RE47,284 E

Page 2

(51) **Int. Cl.**
B23P 15/26 (2006.01)
F25D 29/00 (2006.01)

(56) **References Cited**

U.S. PATENT DOCUMENTS

6,256,075 B1 * 7/2001 Yang 348/843
6,310,767 B1 * 10/2001 Spear et al. 361/679.24
6,480,243 B2 * 11/2002 Yamamoto 348/836
6,575,541 B1 * 6/2003 Hedrick et al. 312/223.1
7,046,310 B2 * 5/2006 Lee 348/836
7,155,923 B2 * 1/2007 Nam et al. 622/259.2
7,260,954 B2 * 8/2007 Jang et al. 62/285
7,516,625 B2 * 4/2009 Kwon 62/440
7,942,013 B2 * 5/2011 Kim 62/125
8,109,580 B1 * 2/2012 Didier et al. 312/245
8,375,639 B2 * 2/2013 Lee et al. 49/463
8,770,684 B2 * 7/2014 Kim F25D 29/005
312/405.1
2004/0177624 A1 * 9/2004 Wo 62/125
2004/0183413 A1 * 9/2004 Koo 312/401
2005/0097912 A1 * 5/2005 Nam et al. 62/331
2005/0146250 A1 * 7/2005 Chung et al. 312/7.2
2005/0190309 A1 * 9/2005 Takita et al. 348/840
2006/0201043 A1 * 9/2006 Kim et al. 40/725
2007/0056303 A1 * 3/2007 Choi et al. 62/259.2
2007/0096606 A1 * 5/2007 Ryu 312/7.2
2008/0164796 A1 * 7/2008 McCoy et al. 312/405
2008/0165998 A1 * 7/2008 LeClear et al. 381/345

2008/0202844 A1 * 8/2008 LeClear et al. 181/148
2008/0231159 A1 * 9/2008 Lee et al. 312/405
2008/0238279 A1 * 10/2008 Jang 312/405
2008/0297012 A1 * 12/2008 Cooper 312/7.2
2008/0297013 A1 * 12/2008 Iwai et al. 312/7.2
2010/0019639 A1 * 1/2010 Son 312/403
2010/0024466 A1 * 2/2010 Kwon 62/449
2010/0066226 A1 * 3/2010 Luisi et al. 312/405.1
2012/0099255 A1 * 4/2012 Lee et al. 361/679.01

FOREIGN PATENT DOCUMENTS

GB 2186311 A * 8/1987
JP 03036481 A * 2/1991 F25D 29/005
JP 2000088445 A * 3/2000
JP 2001153538 A * 6/2001
JP 2002039673 A * 2/2002
JP 2002090059 A * 3/2002
JP 2007298242 A * 11/2007
KR 20-2001-0001242 U 1/2001
KR 2005081017 A * 8/2005
KR 10-0634365 B1 10/2005
KR 10-0582082 B1 5/2006
KR 10-0634367 B1 10/2006
KR 10-2007-0034835 A 3/2007
WO WO 03/081153 A1 * 10/2003
WO WO 2007011178 A1 * 1/2007 F25D 23/02
WO WO 2007060188 A2 * 5/2007 F24C 7/082
WO WO 2007078149 A1 * 7/2007

* cited by examiner

Fig. 1

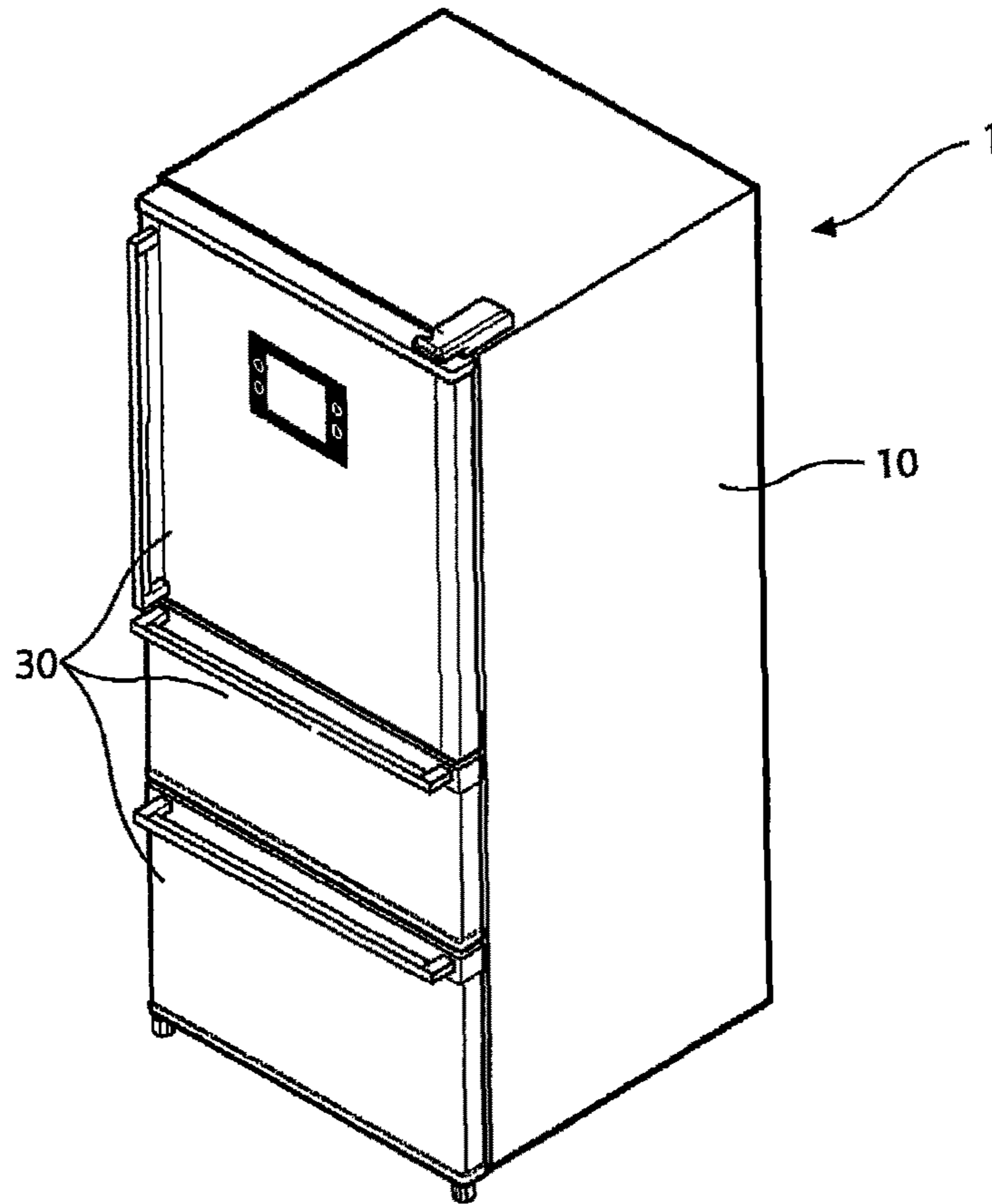

Fig. 2

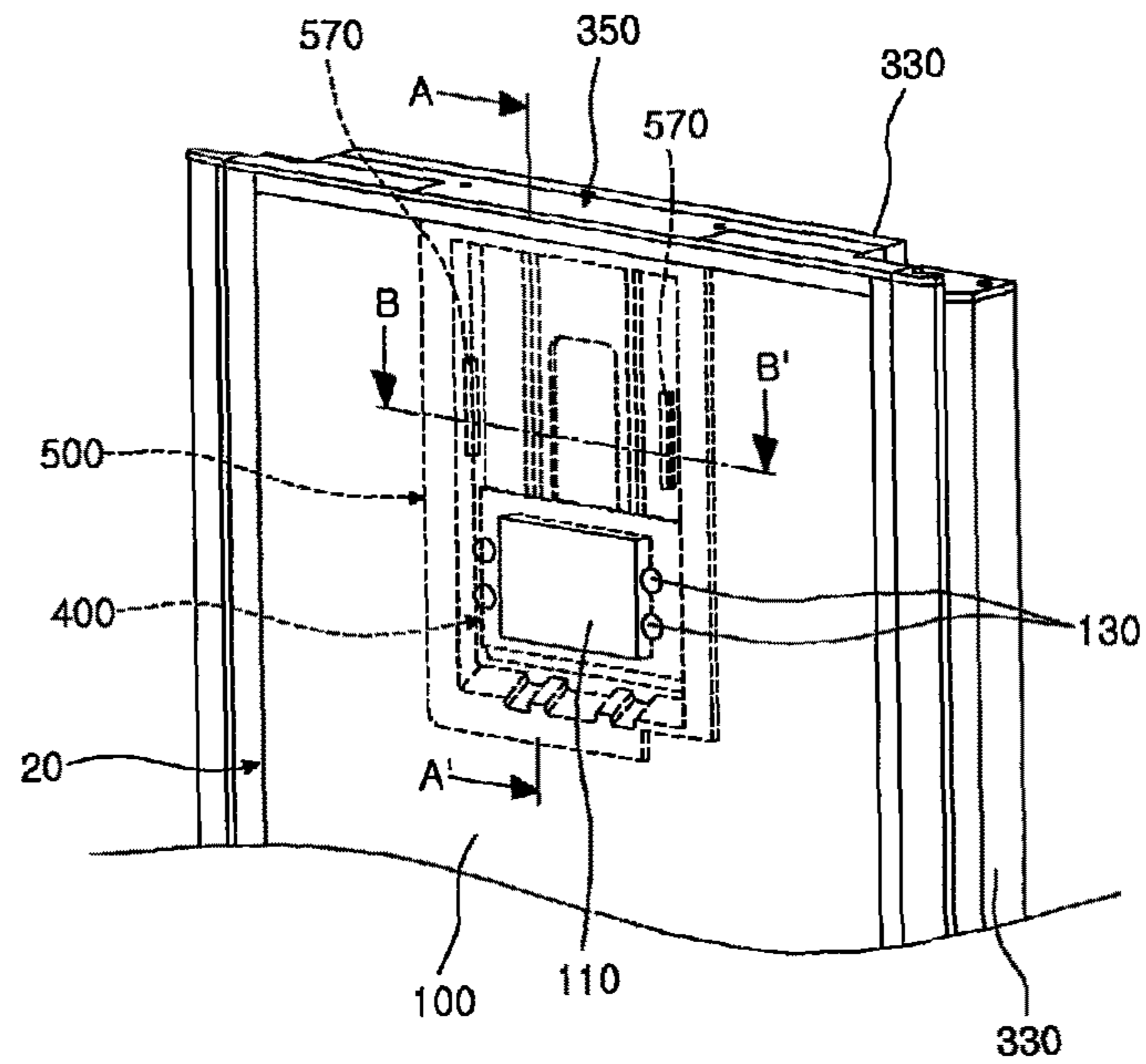

Fig. 3

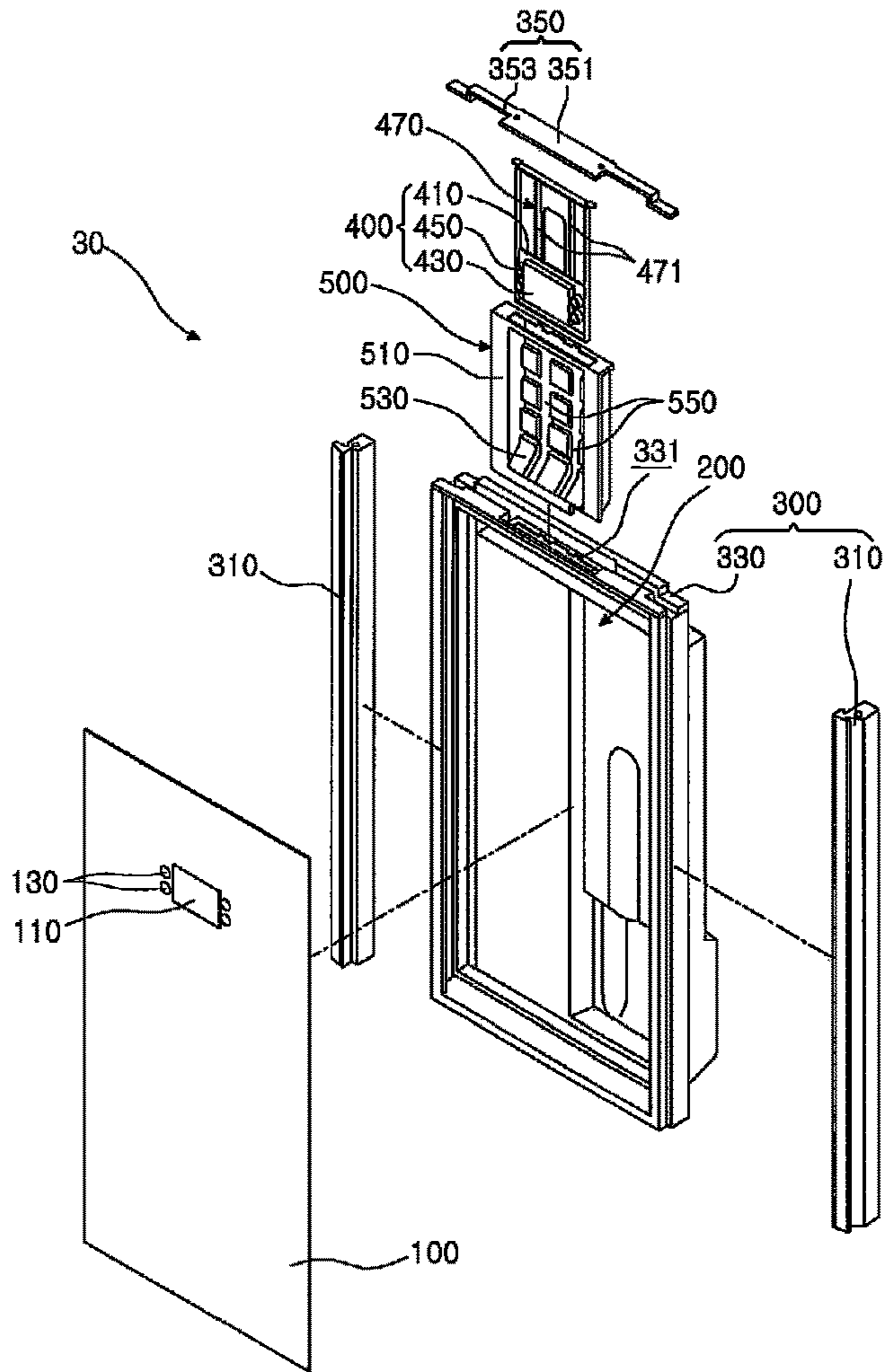

Fig. 4

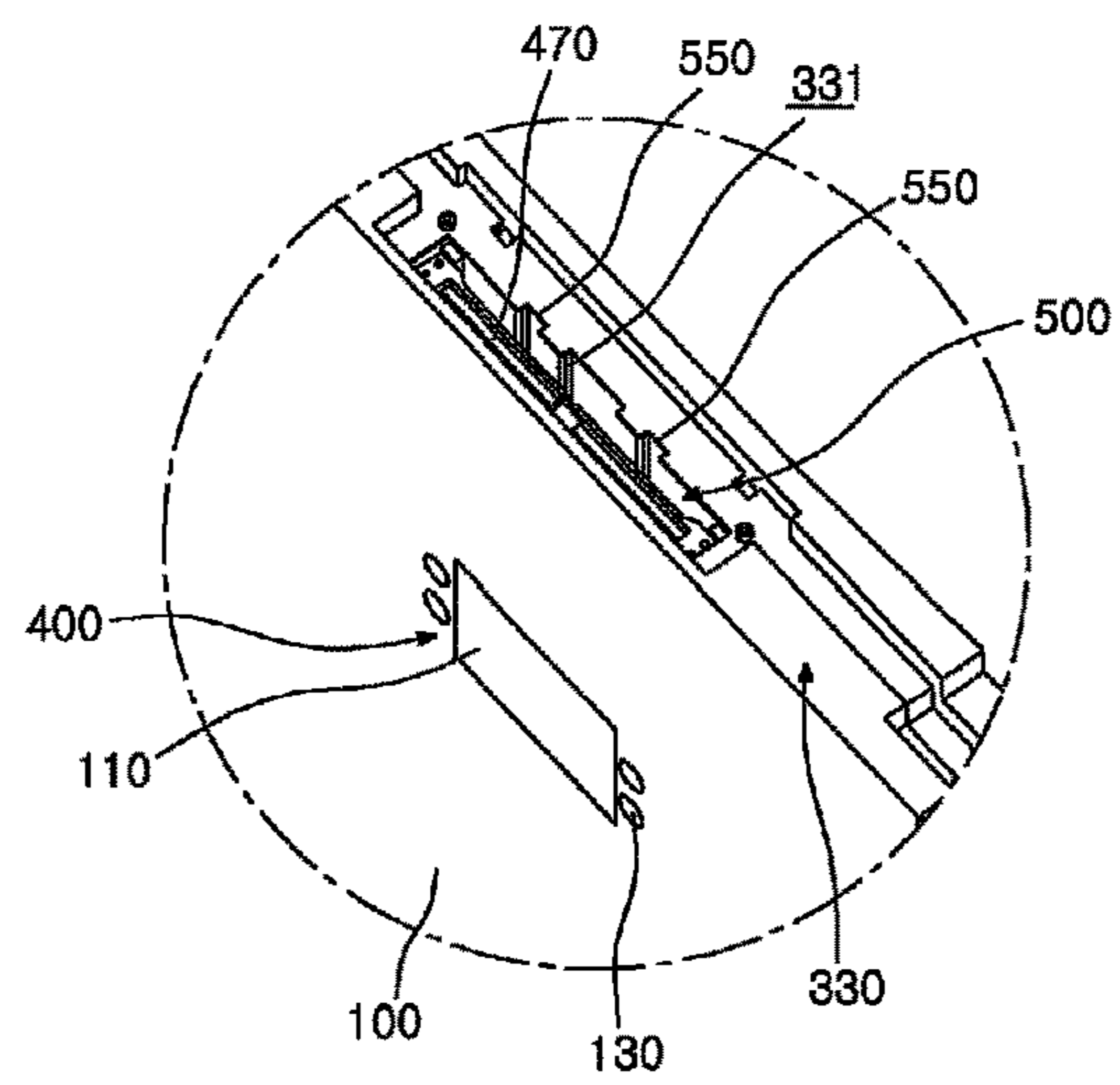

Fig. 5

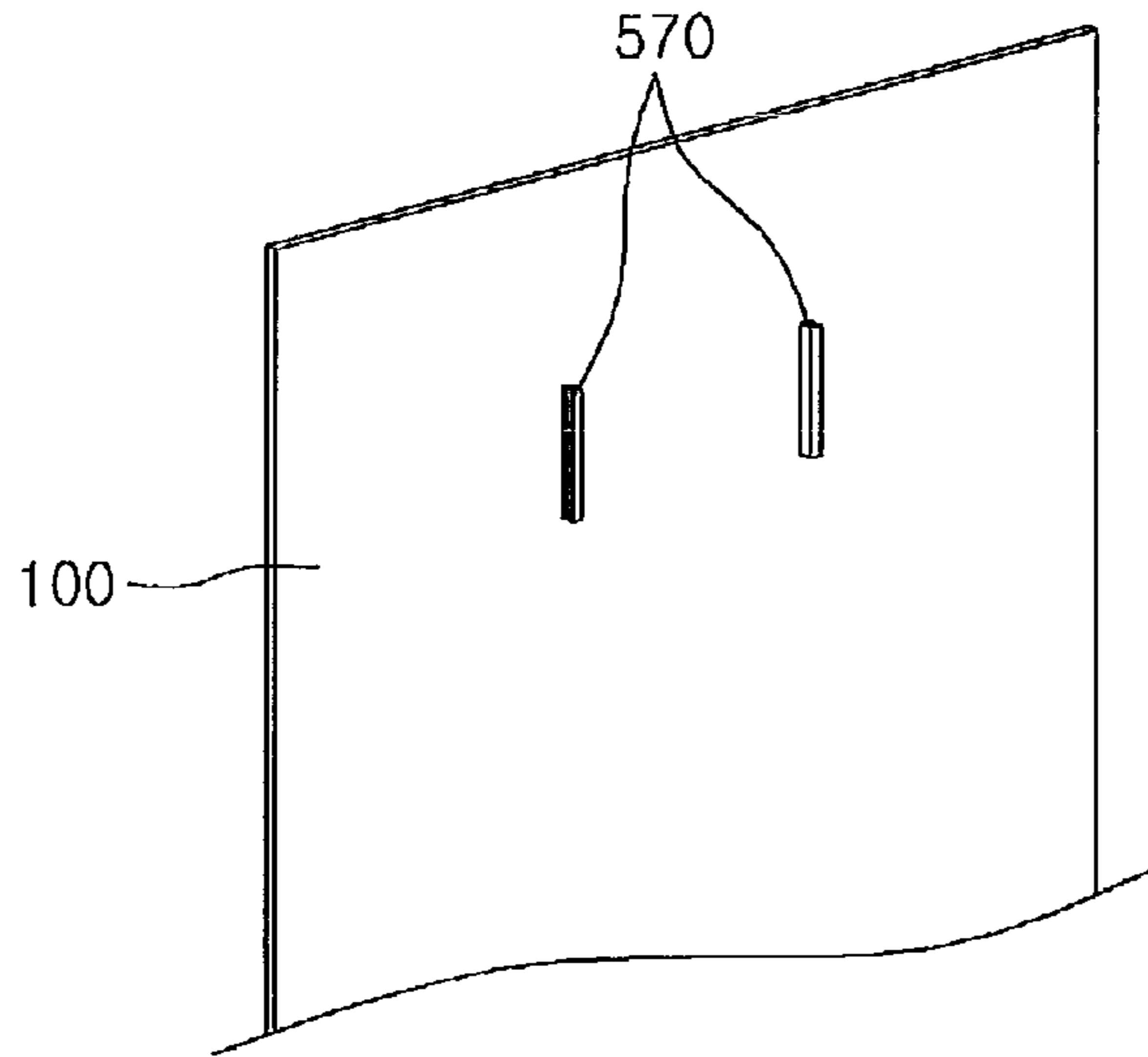

Fig. 6

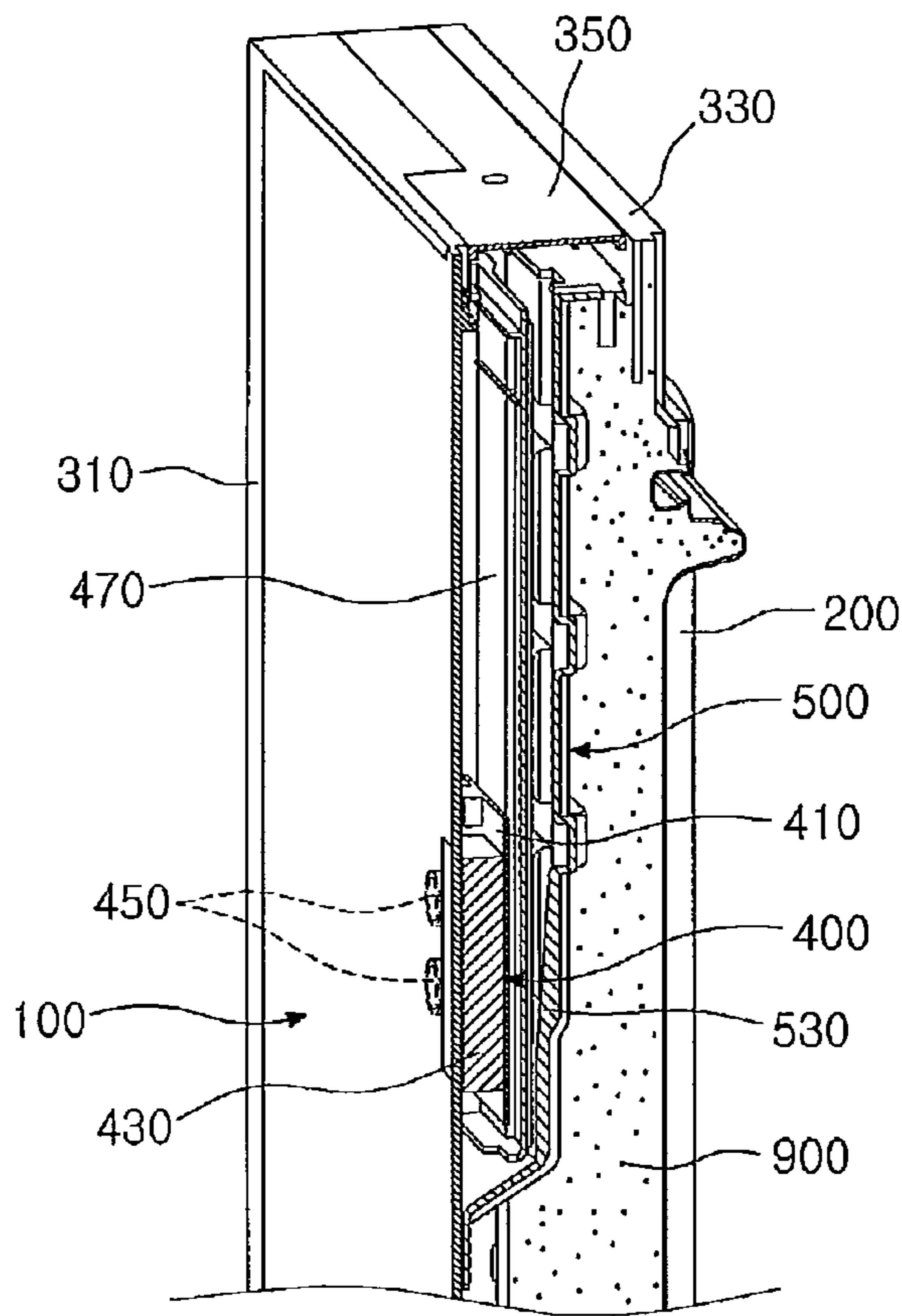

Fig. 7

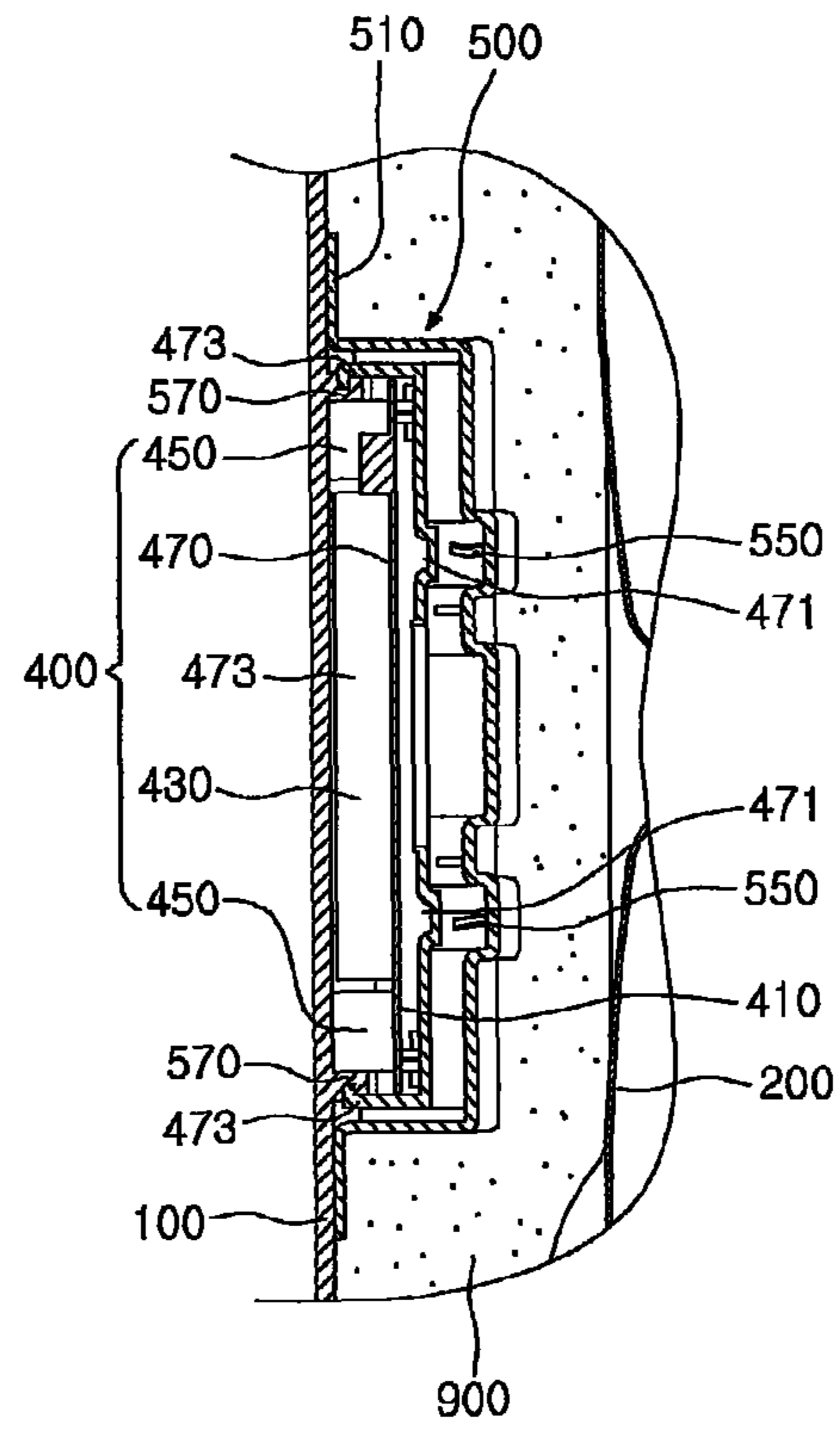

Fig. 8

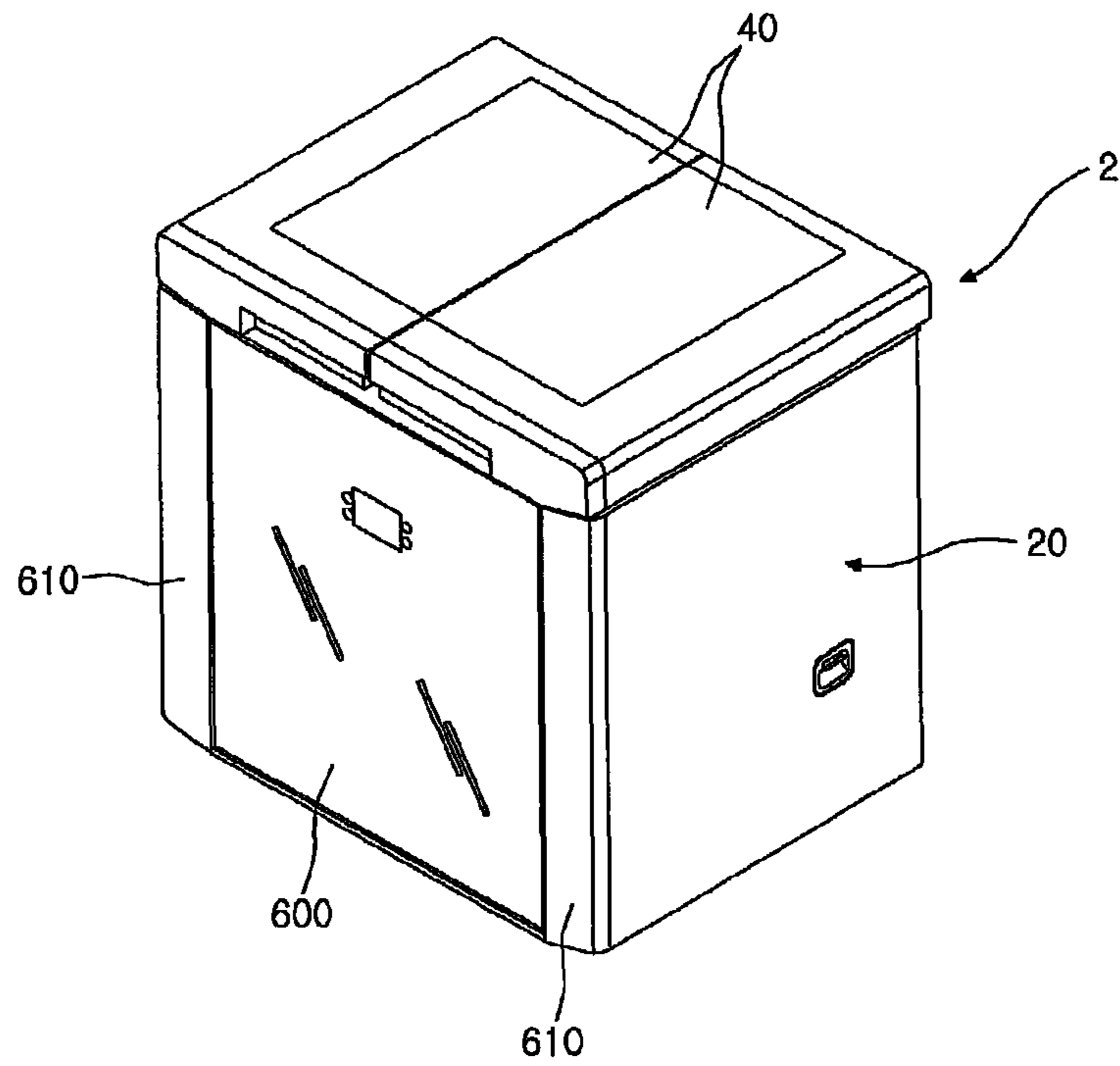
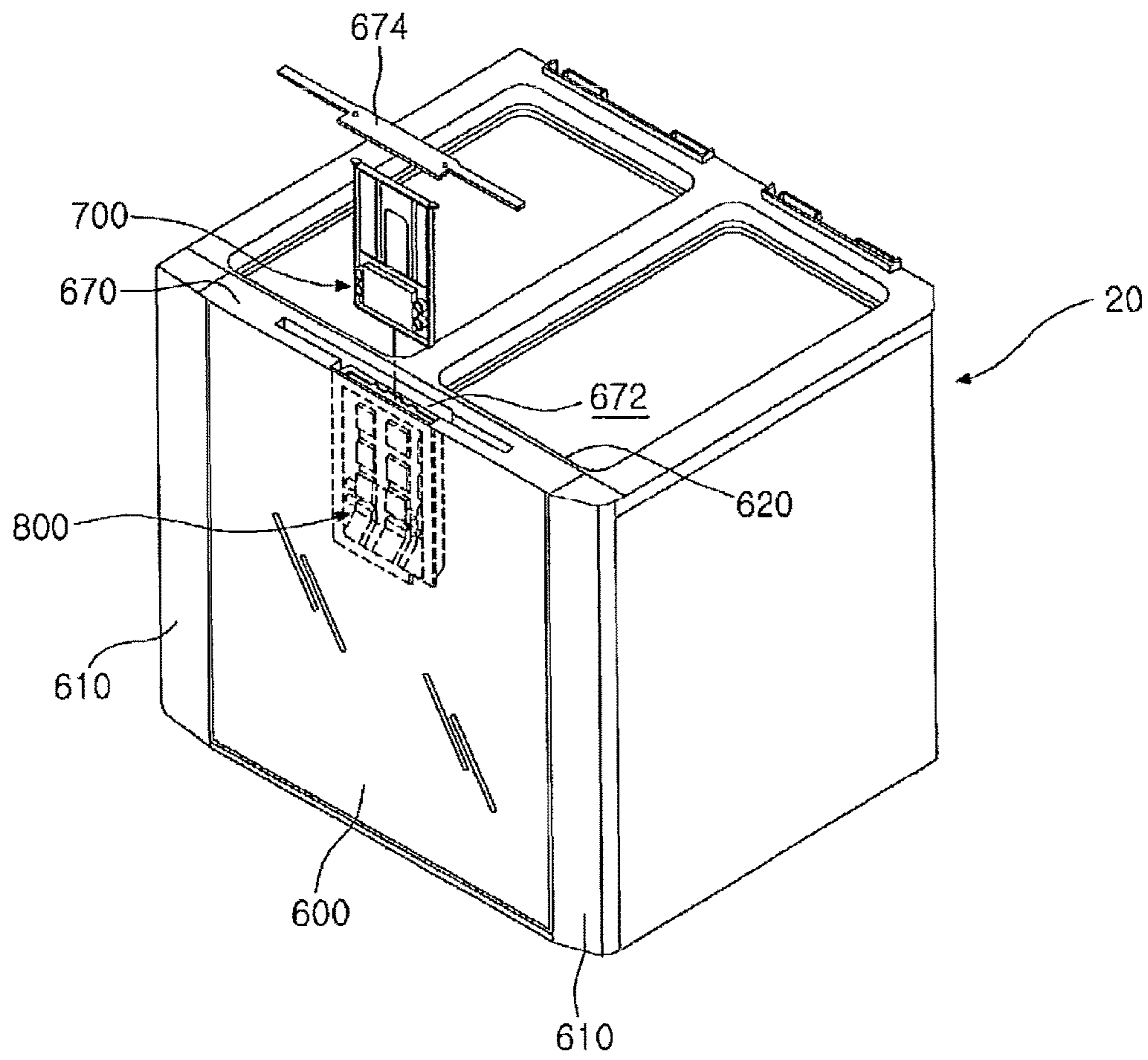

Fig. 9



REFRIGERATOR AND MANUFACTURING METHOD OF THE SAME

Matter enclosed in heavy brackets [] appears in the original patent but forms no part of this reissue specification; matter printed in italics indicates the additions made by reissue; a claim printed with strikethrough indicates that the claim was canceled, disclaimed, or held invalid by a prior post-patent action or proceeding.

This application is a Reissue Application of U.S. Pat. No. 8,523,304 issued Sep. 3, 2013, which is the national phase of PCT International Application No. PCT/KR2008/007498 filed on Dec. 17, 2008, and which claims priority to Application No. 10-2008-0015776 filed in the Republic of Korea on Feb. 21, 2008.

TECHNICAL FIELD

The present embodiment relates to a refrigerator and a manufacturing method of the same.

BACKGROUND ART

A refrigerator is an apparatus storing for foods at a low temperature. The refrigerator includes a main body in which a storage chamber is formed and a door coupled to the main body to open/close the storage chamber. And, a display unit displaying at least an operation state of the refrigerator is provided in the main body or the door.

DISCLOSURE OF INVENTION

Technical Problem

An object of the present embodiment is to provide a refrigerator that is easily mounted with a display unit, and has a simple structure and a low manufacturing cost.

Technical Solution

According to one aspect of the present embodiment, there is provided a refrigerator having a main body in which a storage chamber is formed and a door to open/close the storage chamber, the refrigerator comprising: a panel member forming at least a portion of the exterior of the refrigerator; an inner case of which at least portion is spaced from the panel; a display case provided at one side of the panel member; insulating material filled in space between the panel member and the inner case; and a display unit mounted on the display unit after the filling of the insulating material is completed.

According to another aspect of the present embodiment, there is provided a manufacturing method of a refrigerator comprising: filling insulating material between an inner case and a panel member forming a portion of the exterior of the refrigerator; and inserting a display unit into space between the insulating material and the panel member.

According to another aspect of the present embodiment, there is provided a manufacturing method of a refrigerator comprising: forming a mounting space for mounting a display unit and an insulation space for insulating between an inner case and a panel member forming a portion of the exterior of the refrigerator; filling the insulating material in the insulation space; mounting the display unit on the

mounting space; and covering the display unit in a state where the display unit is mounted.

Advantageous Effects

With the proposed embodiment, the display unit is mounted on an inner side of the door or an inner side of the body so that the display unit is not exposed to the outside of the front panel, making it possible to improve an esthetic sense of the front panel.

Also, the display unit is inserted into the door or the body after the filling of insulating material is completed, making it possible to simplify assembly of the door or the body and to reduce a manufacturing cost.

The display unit can be slidingly drawn-out from the door or the main body, making it possible to check and repair the display unit.

BRIEF DESCRIPTION OF THE DRAWINGS

The above and other objects, features and advantages of the present invention will become apparent from the following description of preferred embodiments given in conjunction with the accompanying drawings, in which:

FIG. 1 is a perspective view of the exterior of a refrigerator according to a first embodiment;

FIG. 2 is a partial perspective view of a refrigerator door according to a first embodiment;

FIG. 3 is an exploded perspective view of a refrigerator door according to a first embodiment;

FIG. 4 is a partial perspective view showing a structure that a display unit according to a first embodiment is mounted to a refrigerator door;

FIG. 5 is a rear perspective view of a front plate constituting a refrigerator door according to a first embodiment;

FIG. 6 is a cross-sectional view taken along line A-A' of FIG. 2;

FIG. 7 is a cross-sectional view taken along line B-B' of FIG. 2;

FIG. 8 is a perspective view of a refrigerator according to a second embodiment;

FIG. 9 is a perspective view showing a structure that a display unit according to a second embodiment is inserted to a refrigerator main body.

MODE FOR THE INVENTION

Hereinafter, an embodiment will be described in detail with reference to the accompanying drawings.

FIG. 1 is a perspective view of the exterior of a refrigerator according to a first embodiment, and FIG. 2 is a partial perspective view of a refrigerator door according to a first embodiment.

Referring to FIGS. 1 and 2, the refrigerator 1 according to the present embodiment includes a main body in which a storage chamber is formed, and at least one door 30 coupled movably to the main body 10 to open/close the storage chamber.

Although not shown, the main body 10 includes a panel member and an inner case, wherein a heat insulator such as expanded polystyrene (EPS) is foamy filled between the panel member and the inner case.

A display unit 400 displaying at least an operation state of the refrigerator 1 is provided on the door. And, the display unit 400 allows an operation condition of the refrigerator to be selected by means of a touch method by way of example.

3

A display window **110** allowing information displayed by the display unit **400** to be shown is formed on the front surface of the door corresponding to the position of the display unit through a front surface of the door **30**. The display window **110** is formed to be transparent or translucent.

Manipulating parts **130** guiding a user's touch are displayed on both right and left sides based on the display window **110** of the door **30**. The manipulating parts **130**, which are formed in the portions corresponding to sensing units **450** [(see FIG. 5)] (see FIG. 3) of the display unit **400**, are printed or formed in a rugged shape on the front surface of the door **30** so that they can guide the positions of the sensing units **450**.

And, sensors constituting the sensing units **450**, which are capacitance sensors, sense microcurrent generated at the time of user's touch to generate input signals. Therefore, if a user touches the manipulating parts **130**, the user's manipulation is sensed in the sensing units **450**.

FIG. 3 is an exploded perspective view of a refrigerator door according to a first embodiment, FIG. 4 is a partial perspective view showing a structure that a display unit according to a first embodiment is mounted to a refrigerator door, and FIG. 5 is a rear perspective view of a front plate constituting a refrigerator door according to a first embodiment.

Referring to FIGS. 3 to 5, the door **30** includes a panel member **100** forming at least a portion of the exterior and an inner case **200** forming the shape of a rear surface. And, the panel member **100** is spaced from at least a portion of the inner case to form an insulation space and the insulation space is filled with insulating material **900**.

The panel member **100** and the inner case **200** are coupled to each other by deco members **300**, wherein the deco members **300** are coupled along edge boundaries of the panel member **100** and the inner case **200** to form a boundary surface of the door **30**.

The panel member **100** is formed of tempered glass or plastic material, in an approximate rectangular plate shape, and a pattern is printed on the rear surface of the panel member **100**.

The display window **110** is formed on the panel member **100** to be transparent or translucent. And, as described above, the manipulating parts **130** are formed on both right and left sides of the display window **110**.

In the panel member **100**, portions except the position of the display window **110** are colored and a separate printing job may be performed on the positions of the manipulating parts **130**.

The inner case **200** is formed in a shape corresponding to the opening portion of a storage chamber formed in the main body **10**. And, although not shown, gasket is provided to an edge of the door rider so that the storage chamber can keep airtight.

The deco member **300** includes a plurality of side decoes forming right and left sides of the door **30**, and a plurality of [cab] cap decoes **330** forming up and down surfaces of the door **30**.

Among the plurality of [cab] cap decoes **330**, an inserting part **331** is formed on an upper side deco. The inserting part **331** provides a path for inserting the display unit **400**.

A display case **500** guiding the insertion of the display unit **400** and supporting the display unit **400** is coupled to the upper side deco. And, the display unit **400** is slidingly mounted to the display case **500**, penetrating through the inserting part **331** of the upper side deco.

4

The display case **500** is formed so that its front surface and upper surface are opened.

The display case **500** is coupled to [the cab deco **330** (upper side deco)] an upper side deco of the plurality of cap decoes **330** by a coupling member such as a screw.

And, the upper side deco is coupled to the panel member **100** and the inner case **200** in a state where the display case **500** is coupled to the upper side deco. Then, the display case **500** is positioned between the panel member **100** and the inner case **200**, in a state where the display case **500** is coupled to the upper deco.

The front surface of the display case **500** is closely adhered to the rear surface of the panel member **100**.

A bending part **510** is formed on the boundary of the opened front surface of the display case **500**. The bending part **510** allows the opened front surface of the display case **500** to be closely adhered to the rear surface of the panel member **100**. As the bending part **510** is closely adhered to the panel member **100**, a separated space (display unit mounting space) isolated from the insulation space where the insulating material **900** is foamed may be formed on an inner side of the door **30**.

A plurality of pressure parts **530** are formed on the inner side surface of the display case **500**. The pressure parts **530** are projected forward from the inner side surface of the display case **500**. The pressure parts **530** are closely adhered to the display unit **400** in a state where the display unit **400** is mounted to the display case **500** to pressurize the display unit **400** towards the panel member **100**. As the pressure parts pressurize the rear surface of the display unit, the front surface of the display unit **400** can be closely adhered to the rear surface of the panel member **100** so that a back and forth movement of the display unit is prevented.

Guide rails **550** are formed on the inner surface of the display case **500**. The guide rails **550** are formed by embedding a portion of the display case **500** backward and are extended upward and downward.

A plurality of guide rails **550** may be provided for a more stable sliding of the display unit **400**, wherein the plurality of guide rails **550** are spaced right and left at a predetermined interval.

Meanwhile, a plurality of mounting guides **570** are provided on the rear surface of the panel member **100**. The plurality of mounting guides **570** may, for example, be formed of plastic material to be coupled to the rear surface of the panel member, wherein the plurality of mounting guides **570** are spaced right and left.

The mounting guides **570** are coupled to the display unit **400** to guide the right and left positions to which the display unit **400** is inserted. And, the right and left movement of the display unit **400** can be prevented in a state where the display unit **400** is coupled to the mounting guide **570**.

Of course, the mounting guides **570** may also be formed on the display case **500** rather than on the rear surface of the panel member **100**.

Meanwhile, the display unit **400** includes a PCB board **410**, a display part **430**, a sensing part **450**, and a unit guide **470**. The PCB board **410** electrically connects the sensing part **450** to the display part **430** and controls each driving thereof.

The display part **430** is positioned in a central portion of the PCB board **410** and displays at least an operation state to the external. The display part **430** may, for example, be a LCD.

The sensing part **450** receives operating signals by a user's touch as described above.

5

The display part **430** and the sensing part **450** are mounted on the PCB board **410**, and the [PCT] PCB board **410** is mounted on the unit guide **470**. And, the unit guide **470** is slidingly mounted on the display case **500**.

Guide parts **471** projected backward are formed on the rear surface of the unit guide **470**. And, the guide parts **471** are formed to be vertically long and are inserted into the inner sides of the guide rails **550**.

Guide ribs **473** are formed on both right and left stages of the unit guide **470**. The guide ribs **473** are coupled to the mounting guide **570**.

A cover member **350** is coupled to the upper side deco. The cover member **350** selectively covers the inserting part **331**. The cover member **350** includes a shielding part **351** shielding the inserting part **331** and a mount part **353** extended to both sides of the shielding part **351** to be coupled to the upper side deco.

In the present embodiment, the display unit **400** is described to be inserted into the inside of the door by penetrating through the upper side deco. However, the display unit **400** may also be inserted into the door by penetrating through a lower side deco or through the side deco **310**.

FIG. **6** is a cross-sectional view taken along line A-A of FIG. **2**, and FIG. **7** is a cross-sectional view taken along line B-B' of FIG. **2**.

Referring to FIGS. **6** and **7**, an assembling method of the door will be described.

First, in order to assemble the door **30**, the panel member **100** and the door rider **200** are prepared. And, the panel member **100** and the inner case **200** are coupled to the side deco **310**.

And, the panel member **100** and the inner case **200** are coupled to the lower side deco. And, after coupling the display case **500** to the upper side deco, the panel member **100** and the inner case **200** are coupled to the upper side deco **130**. Then, an insulation space for filling insulating material **900** and a mounting space for mounting the display unit **400** are partitionally provided on the inner side of the door **30**.

After the respective decoes **310** and **330** are coupled to the panel member **100** and the inner case **200**, the insulating material **900** is foamly filled excepting for the space for mounting the display unit **400**.

After the foam filling of the insulating material **900** on the inner side of the door **30** is completed, the display unit **400** is inserted into the inserting part **331** of the upper side deco. Then, the display unit **400** is coupled to the respective mounting guides **570** to be slidingly mounted to the display case **500**.

After the display unit **400** is mounted on the display case **500**, the cover member **350** is coupled to the upper side deco, thereby completing the assembling of the door.

Meanwhile, when the display unit **400** is checked or is trouble, the display unit **400** can be drawn out by the isolating cover member **350** from the upper side deco and then allowing the unit guides **470** to be slid upward. And, after the work is completed, the unit guide can be inserted again into its original position.

With the present embodiment, the display unit is mounted on the inner side of the door so that the display unit is not exposed to the outer side of the front panel, having an advantage that an esthetic sense of the front panel is improved.

Also, the display unit is inserted to the door after the filling of the insulating material is completed, having advantages that the assembling of the door is simplified and a manufacturing cost is reduced.

6

Also, the display unit can be slidingly drawn out from the door, having an advantage that the display unit can be checked and repaired.

FIG. **8** is a perspective view of a refrigerator according to a second embodiment, and FIG. **9** is a perspective view showing a structure that a display unit according to a second embodiment is inserted to a refrigerator main body.

The present embodiment is the same as the first embodiment, excepting for the position on which the display unit is mounted. Therefore, only the characteristic portion of the present embodiment will be described hereinafter.

Referring to FIGS. **8** and **9**, the refrigerator **2** according to the present embodiment includes a main body **20** in which a storage chamber is formed, and a door **40** coupled to an upper side of the main body **20** to open/close the storage chamber.

The main body **20** includes a panel member **600** forming at least a portion of the exterior and an inner case **620**. Insulating material is foamly filled between the panel member **600** and the inner case **620**.

The panel member **600** may, for example, be formed of tempered glass or plastic material, and the position of the panel member may be fixed by a side deco **610**.

And, a [cab] cap deco **670** is coupled to an upper side of the panel member **600**. An inserting part **672** for inserting a display unit **700** is inserted is formed on the [cab] cap deco. And, a display case **700** for mounting the display unit **700** is coupled to the [cab] cap deco **670**. Also, a cover member **674** for covering the inserting part is coupled to the [cab] cap deco. And, the display unit is slidingly mounted to the display case after the insulating material between the panel member and the inner case is foamly filled.

The shape and coupling method of the display case are the same as those of the first embodiment so that the detailed description thereof will be omitted. Also, the mounting method of the display is the same as that of the first embodiment so that the detailed description thereof will be omitted.

Those skilled in the art will appreciate that the conceptions and specific embodiments disclosed in the foregoing description may be readily utilized as a basis for modifying or designing other embodiments for carrying out the same purposes of the present invention. Those skilled in the art will also appreciate that such equivalent embodiments do not depart from the spirit and scope of the invention as set forth in the appended claims.

The invention claimed is:

[1] A refrigerator having a main body in which a storage chamber is formed and a door to open/close the storage chamber, the door comprising:

- a panel member forming at least a portion of a front exterior of the door, a pattern on a rear surface of the panel member;
- a display case installed on a rear surface of the panel member and having a display mounting space;
- an inner case, forming at least a portion of a rear exterior of the door;
- a connecting member forming at least a portion of a side exterior of the door, the connecting member having a display insertion hole;
- insulating material filled in a space defined by the panel member, the inner case, and the connecting member, the insulating material being in contact with the panel member, the inner case, the connecting member and the display case;
- a display unit passing through the display insertion hole and mounted on the display mounting space after the

7

filling of the insulating material is completed, the display unit having a display part, a sensing part and a unit guide, wherein the display part and the sensing part are installed on the unit guide;
 at least one pressure part configured to pressurize the display unit toward the panel member and disposed within the display case; and
 a cover coupled to the connecting member and configured to cover the display insertion hole,
 wherein the sensing part of the display unit senses a touch of a user when the user touches the panel member.]

[2. The refrigerator according to claim 1, wherein the display case is coupled to the connecting member.]

[3. The refrigerator according to claim 1, wherein the display case is closely adhered to the panel member in a state where the display unit is mounted on the display case.]

[4. The refrigerator according to claim 1, wherein the panel member includes mounting guides coupled to the display unit, and
 wherein the display unit includes guide ribs coupled to the mounting guides.]

[5. The refrigerator according to claim 1, wherein the display unit is slidingly mounted on the display case,
 wherein the display unit includes guide parts guiding the mounting of the display unit, and
 wherein the display case includes guide rails guiding the sliding of the guide parts.]

[6. The refrigerator according to claim 1, wherein the panel member includes a manipulating part guiding the position of the sensing part,
 wherein a display window is formed in the position corresponding to the display part, and
 wherein the display window is formed to be transparent or translucent.]

[7. A refrigerator having a main body in which a storage chamber is formed and a door to open/close the storage chamber, the door comprising:

a panel member that forms at least a portion of a front exterior of the door;

an inner case that forms at least a portion of a rear exterior of the door, at least a portion of the inner case being spaced from the panel member;

a deco member that forms at least one of a side, upper or lower exterior of the door;

a display case installed on a rear surface of the panel member;

insulating material filled in a space defined by the panel member, the deco member and the inner case;

a display inserting part formed on the deco member;

a display unit mounted on the display case after the filling of the insulating material is completed, the display unit penetrating through the display inserting part, the display unit having a display part, a sensing part and a unit guide, wherein the display part and the sensing part are installed on the unit guide;

at least one pressure part configured to pressurize the display unit toward the panel member and disposed within the display case; and

a cover coupled to the deco member and configured to cover the display inserting part,

wherein the sensing part senses a touch operation of the panel member.]

8. A refrigerator, comprising:

a cabinet having a storage space;

a door opening and closing the storage space, the door comprising:

8

a panel member provided with a display window and configured to form a front exterior of the door of the refrigerator;

an inner case spaced apart from the panel member and configured to form a rear exterior of the door of the refrigerator;

a deco member that connects the panel member and the inner case, configured to form a side exterior, an upper exterior or a lower exterior of the door, and having an inserting part;

a display case disposed within a space defined by the panel member, the inner case, and the deco member, the display case including a first side wall, a second side wall that faces the first side wall, a rear wall that connects the first side wall with the second side wall to define a receiving space, a first opening facing a rear surface of the panel member, and a second opening communicating with the inserting part; and insulating material filled in a space defined by the panel member, the inner case, the deco member and the display case so that the insulating material contacts with the panel member, the inner case, the deco member and the display case;

a display unit inserted into the receiving space of the display case through the inserting part and the second opening; and

a mounting guide mounted on the rear surface of the panel member to guide a mounting location of a unit guide of the display unit and protruded toward a rear surface of the inner case, the unit guide including a guide rib coupled to the mounting guide,

wherein the display unit comprises a printed circuit board, a display part, a sensing part to sense a touch manipulation of a user, and the unit guide, the unit guide including a mounting surface on which the printed circuit board is mounted,

wherein the display case further includes a guide rail formed on the rear wall thereof,

wherein the guide rail includes at least two protrusions protruded toward the panel member and spaced apart from each other to define a recess,

wherein the unit guide includes a guide part protruded toward the rear wall of the display case from a rear surface thereof and received in the recess,

wherein in a state in which the guide rib is coupled to the mounting guide, the guide part is spaced apart from the first and second side walls to define a space,

wherein at least a portion of the rear surface of the unit guide is spaced apart from the rear wall of the display case to define a space, and

wherein the display window faces the display part and covers the display part.

9. The refrigerator according to claim 8, where the display window is spaced apart from an edge portion of the panel member.

10. The refrigerator according to claim 9, wherein the display window is formed to be transparent or translucent.

11. The refrigerator according to claim 8, wherein the display part is a liquid crystal display.

12. The refrigerator according to claim 8, wherein the unit guide is mounted on the display case.

13. The refrigerator according to claim 8, wherein the panel member is formed of glass or plastic material.

14. The refrigerator according to claim 8, wherein a manipulation part to be touched by the user for manipulating is printed or formed in a rugged shape on the panel member corresponding to the sensing part.

15. The refrigerator according to claim 8, wherein the deco member comprises cap decoes, and one of the cap decoes includes the inserting part.

16. The refrigerator according to claim 8, further comprising a cover member to cover the inserting part after the display unit is inserted into the receiving space of the display case.

17. The refrigerator according to claim 16, wherein the cover member comprises a shielding part to shield the inserting part and mount parts extended to both sides of the shielding part to be coupled to the deco member.

18. The refrigerator according to claim 8, further comprising a pressure part configured to pressurize the unit guide toward the rear surface of the panel member.

19. The refrigerator according to claim 18, wherein the pressure part is disposed on the display case.

20. The refrigerator according to claim 18, wherein the pressure part includes an inclined surface inclined toward the rear surface of the panel member.

21. The refrigerator according to claim 8, wherein the mounting guide is formed of plastic material to be attached to the rear surface of the panel member.

22. The refrigerator according to claim 8, wherein the display case is coupled to an inner surface of the deco member.

23. The refrigerator according to claim 8, wherein the display part faces the display window when the unit guide is inserted in the receiving space through the inserting part and the second opening.

24. The refrigerator according to claim 8, wherein the display part is spaced apart from the inserting part in a state where the unit guide is inserted in the receiving space through the inserting part and the second opening.

25. The refrigerator according to claim 8, wherein the display part is located in the first opening when the unit guide is inserted in the receiving space through the inserting part and the second opening.

26. The refrigerator according to claim 8, wherein the insulating material is filled and foamed in the space defined by the panel member, the inner case, the deco member and the display case.

27. The refrigerator according to claim 8, wherein the display case further comprises a bending part, and a front surface of the bending part is closely adhered to the rear surface of the panel member.

28. A refrigerator, comprising:

a cabinet having a storage space;

a door opening and closing the storage space, the door comprising:

a panel member provided with a display window and configured to form a front exterior of the door of the refrigerator;

an inner case spaced apart from the panel member and configured to form a rear exterior of the door of the refrigerator;

a deco member that connects the panel member and the inner case, configured to form a side exterior, an upper exterior or a lower exterior of the door, and having an inserting part;

a display case disposed within a space defined by the panel member, the inner case, and the deco member, the display case including a first side wall, a second side wall that faces the first side wall, a rear wall that connects the first side wall with the second side wall to define a receiving space, a first opening facing a

rear surface of the panel member, a second opening communicating with the inserting part and a pressure part; and

insulating material filled in a space defined by the panel member, the inner case, the deco member and the display case so that the insulating material contacts with the panel member, the inner case, the deco member and the display case;

a display unit inserted into the receiving space of the display case through the inserting part and the second opening, and

a mounting guide mounted on the rear surface of the panel member to guide a mounting location of a unit guide of the display unit and protruded toward a rear surface of the inner case, the unit guide including a guide rib coupled to the mounting guide,

wherein the display unit comprises a printed circuit board, a display part, a sensing part to sense a touch manipulation of a user, and the unit guide including a mounting surface on which the printed circuit board is mounted,

wherein the display case further includes a guide rail formed on the rear wall thereof,

wherein the guide rail includes at least two protrusions protruded toward the panel member and spaced apart from each other to define a recess,

wherein the unit guide includes a guide part protruded toward the rear wall of the display case from a rear surface thereof and received in the recess,

wherein in a state in which the guide rib is coupled to the mounting guide, the guide part is spaced apart from the first and second side walls to define a space,

wherein the pressure part pressurizes the display unit toward the panel member such that at least a portion of the rear surface of the unit guide is spaced apart from the rear wall of the display case to define a space, and is disposed between a rear surface of the unit guide and a front surface of the display case that faces the rear surface of the unit guide, and

wherein the pressure part is projected forward from an inner surface of the display case and is in contact with the rear surface of the unit guide.

29. The refrigerator according to claim 28, wherein the display part is a liquid crystal display.

30. The refrigerator according to claim 28, wherein the display part is spaced apart from the inserting part when the unit guide is inserted in the receiving space through the inserting part and the second opening.

31. The refrigerator according to claim 28, wherein the display part is located in the first opening when the unit guide is inserted in the receiving space through the inserting part.

32. The refrigerator according to claim 31, wherein the display part faces the display window when the unit guide is inserted in the receiving space through the inserting part and the second opening.

33. The refrigerator according to claim 28, wherein the pressure part pressurizes the unit guide toward the panel member.

34. The refrigerator according to claim 28, wherein the mounting guide is formed of plastic material to be attached to the rear surface of the panel member.

35. The refrigerator according to claim 28, wherein the pressure part includes an inclined surface inclined toward the rear surface of the panel member.

36. The refrigerator according to claim 28, wherein a front surface of the display unit is in contact with the rear surface of the panel member.

37. The refrigerator according to claim 28, wherein the display case is coupled to an inner surface of the deco member.

38. The refrigerator according to claim 28, wherein a manipulation part to be touched by the user for manipulating is formed on a front surface of the panel member corresponding to the sensing part.

39. The refrigerator according to claim 38, wherein the sensing part comprises at least one capacitance sensor to sense a micro current generated at the time of a user's touch to generate an input signal.

40. The refrigerator according to claim 28, wherein the deco member comprises cap decoes, and one of the cap decoes includes the inserting part.

41. The refrigerator according to claim 28, further comprising a cover member to cover the inserting part after the display unit is inserted into the receiving space of the display case.

42. The refrigerator according to claim 41, wherein the cover member comprises a shielding part to shield the inserting part and mount parts extended to both sides of the shielding part to be coupled to the deco member.

43. The refrigerator according to claim 28, wherein the display case is closely adhered to the rear surface of the panel member.

44. The refrigerator according to claim 43, wherein the display case further comprises a bending part, and a front surface of the bending part is in contact with the rear surface of the panel member.

45. The refrigerator according to claim 28, wherein the display window is formed to be transparent or translucent.

46. The refrigerator according to claim 28, wherein the panel member is formed of glass or plastic material.

47. The refrigerator according to claim 28, wherein the insulating material is filled and foamed in the space defined by the panel member, the inner case, the deco member and the display case.

48. A refrigerator, comprising:

a cabinet having a storage space;

a door opening and closing the storage space, the door comprising:

a panel member provided with a display window and configured to form a front exterior of the door of the refrigerator;

a mounting guide mounted on a rear surface of the panel member;

an inner case spaced apart from the panel member and configured to form a rear exterior of the door of the refrigerator;

a deco member that connects the panel member and the inner case, configured to form a side exterior, an upper exterior or a lower exterior of the door, and having an inserting part;

a display case disposed within a space defined by the panel member, the inner case, and the deco member, the display case including a first side wall, a second side wall that faces the first side wall, a rear wall that connects the first side wall with the second side wall to define a receiving space, a first opening facing a rear surface of the panel member, and a second opening communicating with the inserting part; and insulating material filled in a space defined by the panel member, the inner case, the deco member and the display case so that the insulating material

contacts with the panel member, the inner case, the deco member and the display case; and

a display unit inserted into the receiving space of the display case through the inserting part and the second opening,

wherein the mounting guide extends in a direction parallel to an insertion direction of the display unit and protrudes from the rear surface of the panel member toward a rear surface of the inner case, and

wherein the display unit comprises a printed circuit board, a display part, a sensing part to sense a touch manipulation of a user, a unit guide including a mounting surface on which the printed circuit board is mounted, and a guide rib configured to be coupled to the mounting guide when the display unit is inserted in the receiving space,

wherein the display case further includes a guide rail formed on the rear wall thereof,

wherein the guide rail includes at least two protrusions protruded toward the panel member and spaced apart from each other to define a recess,

wherein the unit guide includes a guide part protruded toward the rear wall of the display case from a rear surface thereof and received in the recess,

wherein in a state in which the guide rib is coupled to the mounting guide, the guide part is spaced apart from the first and second side walls to define a space, and

wherein at least a portion of the rear surface of the unit guide is spaced apart from the rear wall of the display case to define a space.

49. The refrigerator according to claim 48, wherein the guide rib is formed at a side portion of the unit guide.

50. The refrigerator according to claim 49, wherein the display part is a liquid crystal display.

51. The refrigerator according to claim 49, wherein the guide rib includes a pair of guide ribs.

52. The refrigerator according to claim 51, wherein the mounting guide is provided in plurality as a pair of mounting guides mounted on the rear side of the panel member and spaced apart from each other, and

the pair of guide ribs are coupled to the pair of mounting guides.

53. The refrigerator according to claim 49, wherein the display part is spaced apart from the inserting part in a state where the unit guide is inserted in the receiving space through the inserting part and the second opening.

54. The refrigerator according to claim 49, further comprising a pressure part disposed on the display case to pressurize the display unit toward the panel member and contacting the unit guide.

55. The refrigerator according to claim 54, wherein the pressure part is disposed between a rear surface of the unit guide and a front surface of the display case.

56. The refrigerator according to claim 54, wherein the pressure part is protruded from the display case toward the panel member.

57. The refrigerator according to claim 54, wherein the pressure part includes an inclined surface inclined toward the rear surface of the panel member.

58. The refrigerator according to claim 49, wherein the mounting guide, the unit guide and the display part are disposed within the receiving space.

59. The refrigerator according to claim 48, wherein the mounting guide is formed of plastic material to be attached to the rear surface of the panel member.

60. The refrigerator according to claim 48, wherein the display case further comprises a bending part closely adhered to the rear surface of the panel member.

61. The refrigerator according to claim 48, further comprising a cover member to cover the inserting part after the display unit is inserted into the receiving space of the display case. 5

62. The refrigerator according to claim 48, wherein the display window is formed to be transparent or translucent.

63. The refrigerator according to claim 48, where the display window is spaced apart from an edge portion of the panel member. 10

64. The refrigerator according to claim 48, wherein the panel member is formed of glass or plastic material.

65. The refrigerator according to claim 48, wherein the deco member comprises cap decoes, and one of the cap decoes includes the inserting part. 15

66. The refrigerator according to claim 48, wherein the insulating material is filled and foamed in the space defined by the panel member, the inner case, the deco member and the display case. 20

* * * * *