

US00RE47261E

(19) **United States**
(12) **Reissued Patent**
Sun et al.

(10) **Patent Number:** **US RE47,261 E**
(45) **Date of Reissued Patent:** ***Feb. 26, 2019**

(54) **METHOD AND APPARATUS FOR CONTROLLING LOOP FILTERING OR POST FILTERING IN BLOCK BASED MOTION COMPENSATED VIDEO CODING**

(52) **U.S. Cl.**
CPC **H04N 19/117** (2014.11); **H04N 19/136** (2014.11); **H04N 19/139** (2014.11);
(Continued)

(58) **Field of Classification Search**
CPC .. H04N 19/117; H04N 19/577; H04N 19/139; H04N 19/573; H04N 19/895;
(Continued)

(71) Applicant: **Dolby Laboratories Licensing Corporation**, San Francisco, CA (US)

(56) **References Cited**

(72) Inventors: **Shijun Sun**, Vancouver, WA (US);
Shawmin Lei, Camas, WA (US)

U.S. PATENT DOCUMENTS

(73) Assignee: **Dolby Laboratories Licensing Corporation**, San Francisco, CA (US)

5,072,293 A 12/1991 De Haan et al.
5,126,841 A * 6/1992 Tanaka et al. 375/240.16
(Continued)

(*) Notice: This patent is subject to a terminal disclaimer.

FOREIGN PATENT DOCUMENTS

(21) Appl. No.: **15/651,879**

CA 2374523 7/2001
EP 0 777 388 A2 12/1995
(Continued)

(22) Filed: **Jul. 17, 2017**

OTHER PUBLICATIONS

Related U.S. Patent Documents

Reissue of:

(64) Patent No.: **7,440,501**
Issued: **Oct. 21, 2008**
Appl. No.: **11/105,729**
Filed: **Apr. 13, 2005**

“Index of /av-arch/video-site/0109.sub.--San”, Sep. 4, 2001, pp. 1-4, XP002606104, Retrieved from the Internet: URL:http://ftp.itu3.int/av-arch/video-site/0109.sub.--San [retrieved on Oct. 4, 2005].
(Continued)

U.S. Applications:

(60) Continuation of application No. 14/512,165, filed on Oct. 10, 2014, now Pat. No. Re. 46,482, which is an
(Continued)

Primary Examiner — Adam L Basehoar

(51) **Int. Cl.**
H04B 1/66 (2006.01)
H04N 19/117 (2014.01)

(57) **ABSTRACT**

Adjacent blocks are identified in an image. Coding parameters for the adjacent blocks are identified. Deblock filtering between the identified adjacent blocks is skipped if the coding parameters for the identified adjacent blocks are similar and not skipped if the coding parameters for the identified adjacent blocks are substantially different.

(Continued)

1 Claim, 5 Drawing Sheets

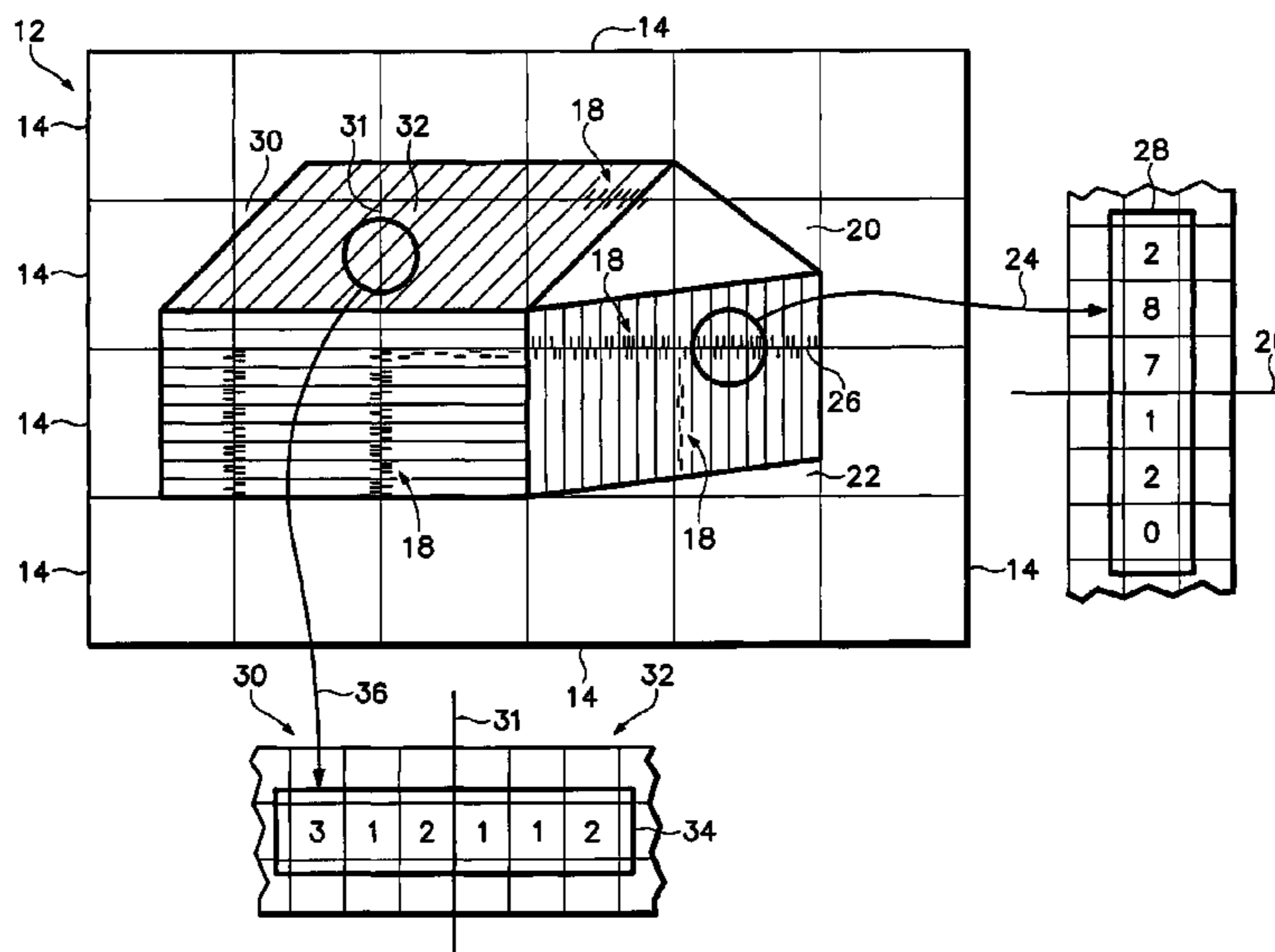

Related U.S. Application Data

application for the reissue of Pat. No. 7,440,501, and a continuation of application No. 13/954,817, filed on Jul. 30, 2013, now Pat. No. Re. 45,250, which is an application for the reissue of Pat. No. 7,440,501, and a continuation of application No. 13/495,944, filed on Jun. 13, 2012, now Pat. No. Re. 44,497, which is an application for the reissue of Pat. No. 7,440,501, and a continuation of application No. 12/908,690, filed on Oct. 20, 2010, now Pat. No. Re. 43,628, which is an application for the reissue of Pat. No. 7,440,501, which is a division of application No. 09/817,701, filed on Mar. 26, 2001, now Pat. No. 6,931,063.

(51) **Int. Cl.**

H04N 19/577 (2014.01)
H04N 19/196 (2014.01)
H04N 19/61 (2014.01)
H04N 19/136 (2014.01)
H04N 19/80 (2014.01)
H04N 19/82 (2014.01)
H04N 19/527 (2014.01)
H04N 19/895 (2014.01)
H04N 19/573 (2014.01)
H04N 19/139 (2014.01)
H04N 19/176 (2014.01)
H04N 19/86 (2014.01)
H04N 19/60 (2014.01)
H04N 19/132 (2014.01)
G06T 5/00 (2006.01)

(52) **U.S. Cl.**

CPC *H04N 19/196* (2014.11); *H04N 19/527* (2014.11); *H04N 19/573* (2014.11); *H04N 19/577* (2014.11); *H04N 19/61* (2014.11); *H04N 19/80* (2014.11); *H04N 19/82* (2014.11); *H04N 19/895* (2014.11); *G06T 5/001* (2013.01); *H04N 19/132* (2014.11); *H04N 19/176* (2014.11); *H04N 19/60* (2014.11); *H04N 19/86* (2014.11)

(58) **Field of Classification Search**

CPC *H04N 19/196*; *H04N 19/527*; *H04N 19/82*; *H04N 19/61*; *H04N 19/136*; *H04N 19/80*; *H04N 19/60*; *H04N 19/132*; *H04N 19/86*; *H04N 19/176*; *G06T 5/001*
 USPC 375/240.16, 240.18, 240.25, 240.29; 382/233, 236, 239, 254, 264, 266, 268, 382/269

See application file for complete search history.

(56)

References Cited

U.S. PATENT DOCUMENTS

5,329,318 A 7/1994 Keith
 5,367,385 A 11/1994 Yuan
 5,473,384 A 12/1995 Jayant et al.
 5,479,211 A 12/1995 Fukuda
 5,565,921 A 10/1996 Sasaki et al.
 5,654,759 A 8/1997 Augenbraun et al.
 5,731,840 A 3/1998 Kikuchi et al.
 5,737,019 A * 4/1998 Kim 375/240.25
 5,768,433 A 6/1998 Bolton
 5,787,204 A 7/1998 Fukuda
 5,852,682 A 12/1998 Kim
 5,933,542 A 8/1999 Chang et al.
 5,949,908 A 9/1999 Sugahara
 5,974,196 A 10/1999 Chang et al.
 5,987,184 A 11/1999 Kweon et al.

6,041,145 A 3/2000 Hayashi et al.
 6,044,177 A 3/2000 Herley
 6,057,884 A 5/2000 Chen et al.
 6,104,434 A 8/2000 Nakagawa et al.
 6,115,503 A 9/2000 Kaup
 6,144,700 A 11/2000 Kim
 6,160,503 A * 12/2000 Andrews et al. 341/94
 6,167,157 A 12/2000 Sugahara
 6,263,026 B1 7/2001 Je-Chang et al.
 6,424,676 B1 7/2002 Kono et al.
 6,618,445 B1 * 9/2003 Peng et al. 375/240.25
 6,665,346 B1 12/2003 Lee et al.
 6,748,113 B1 6/2004 Kondo et al.
 6,907,079 B2 6/2005 Gomila et al.
 6,931,063 B2 8/2005 Sun et al.
 7,120,197 B2 10/2006 Lin et al.
 7,319,415 B2 1/2008 Gomila
 7,440,501 B2 10/2008 Sun et al.
 7,627,034 B2 12/2009 Park et al.
 RE43,628 E 9/2012 Sun et al.
 RE44,497 E 9/2013 Sun et al.
 8,600,179 B2 12/2013 Park et al.
 RE45,250 E 11/2014 Sun et al.
 9,942,573 B2 * 4/2018 Sadafale H04N 19/159
 2001/0017944 A1 8/2001 Kalevo et al.
 2002/0136303 A1 9/2002 Sun et al.
 2004/0101059 A1 5/2004 Joch et al.
 2004/0184549 A1 * 9/2004 Webb H04N 19/174
 375/240.29
 2004/0190626 A1 9/2004 Sun et al.
 2005/0002646 A1 1/2005 Sato
 2005/0053288 A1 * 3/2005 Srinivasan H04N 19/00
 382/233
 2006/0146941 A1 7/2006 Cha et al.
 2007/0160133 A1 7/2007 Bao et al.
 2008/0095244 A1 * 4/2008 Kim H04N 19/527
 375/240.24
 2008/0240252 A1 10/2008 He

FOREIGN PATENT DOCUMENTS

EP 0 714 209 A2 5/1996
 EP 0714209 5/1996
 EP 0 777 388 A2 4/1997
 EP 0777388 6/1997
 EP 0 838 955 A2 7/1997
 EP 0 838 955 A2 4/1998
 EP 0838955 4/1998
 JP 05-227518 9/1993
 JP 08-205178 8/1996
 JP 08-265762 10/1996
 JP 10-093966 4/1998
 JP 10-191351 7/1998
 JP 11-018085 1/1999
 JP 11-275584 10/1999
 JP 2000-059769 2/2000
 JP 2000-299864 10/2000
 JP 2001-094996 4/2001
 JP 2001-204029 7/2001
 JP 2001-224031 8/2001
 JP 2004-328634 11/2004
 JP 2005-503737 2/2005
 JP 2006-191576 7/2006
 KR 10-1997-0078645 12/1997
 WO WO2000/014685 3/2000

OTHER PUBLICATIONS

“Working Draft 1.0 of 14496-10: 200x/AMD1 Scalable Video Coding” ITU Study Group 16—Video Coding Experts Group—ISO/IEC MPEG & ITU-T VCEG/ISO/IEC JTC1/SC29/WG11 and ITU-T SG16 Q6), No. N6901, Feb. 5, 2005 (Feb. 5, 2005), XP030013621.
 “Working Draft 4 of ISO/IEC 14496-10: 200x/Amd.3 Scalable Video Coding” ITU Study Group 16—Video Coding Experts Group—ISO/IEC MPEG & ITU-T VCEG/ISO/IEC JTC1/SC29/WG11 and ITU-T SG16 Q6), No. N7555, Oct. 28, 2005 (Oct. 28, 2005), XP030014100 p. 118-p. 119.

(56)

References Cited

OTHER PUBLICATIONS

- Bjontegaard G.: "H.26L Test Model Long Term No. 7 (TML-7) draft 0" ITU—Telecommunications Standardization Sector, Study Group 16, Video Coding Experts Group; Document VCEG-M81, May 3, 2001; Austin Texas, USA Apr. 2-4, 2001.
- Bjontegaard, Gisle (Editor), "H.26L Test Model Long Term No. 6 (TML-6) draft0", ITU Telecommunications Standardization Sector, Study Group 16, Video Coding Experts Group (VCEG), 12.sup.TH meeting, Eibsee, Germany, Jan. 9-12, 2001.
- Derviaux C et al.: "Blocking Artifact Reduction of DCT Coded Image Sequences Using a Visually Adaptive Postprocessing" Proceedings of the International Conference on Image Processing (ICIP), Lausanne, Sep. 16-19, 1996, New York, IEEE, US, vol. 1, Sep. 16, 1996 pp. 5-8.
- Francois E. et al: "Extended Spatial Scalability" International Organisation for Standardisation Organisation International De Normalisation, ISO/IEC JTC1/SC29/WG11, Coding of Moving Pictures and Audio, ISO/IEC JTC1/SC29/WG11, Coding of Moving Pictures and Audio, ISO/IEC JTC1/SC29/WG11, MPEGG2005/M11669 Jan. 2005 Hong Kong.
- Han W. et al.: "Response of SVC CE-3: Interlayer prediction" ITU Study Group 16—Video Coding Experts Group—ISO/IEC MPEG & ITU-T VCEG (ISO/IEC JTC1/SC29/WG11 and ITU-T SG16 Q6), No. M11585, Jan. 11, 2005 (Jan. 11, 2005), XP030040330.
- He Y; Wu F; Li S; Zhong 7; Yang S: "H.26L—Based Fine Granularity Scalable Video Coding" Proceedings—IEEE International Symposium on Circuits and Systems, vol. 4, 2002, pp. IV-548-IV-551, XP002593544 ISSN:0271-4310.
- Kim C. et al.: "Simplified Loop Filter for Mobile Service (VCEG-M43)" ITU—Telecommunication Standardization Sector Study Group 16, VCEG-M43, Austin, Texas, Apr. 2-4, 2001, generated Mar. 28, 2001.
- Kim S. D. et al.: "A Deblocking Filter with Two Separate Modes in Block-Based Video Coding", IEEE Transactions on Circuits and Systems for Video Technology, vol. 9, No. 1, Feb. 1999; pp. 156-160.
- Lee Y. L. et al.: "Loop-filtering and post-filtering for low bit-rates moving picture coding," 1999. ICIP 99. Proceedings, 1999 International Conference on Kobe, Japan Oct. 24-28, 1999, Piscataway, NJ, USA, IEEE, US, vol. 1, pp. 94-98, Oct. 24, 1999.
- List P. et al. "H.26L Test Model Long Term No. 8.40 (TML-8.4), Software Module: loop-filter.c" ITU—Telecommunications Standardization Sector Study Group 16, VCEG, [Online] Aug. 29, 2001, pp. 1-3, XP002440062, Santa Barbara, CA, USA.
- List P. et al.: "Adaptive Deblocking Filter" IEEE Transactions on Circuits and Systems for Video Technology, IEEE Service Center, Piscataway, NJ, US LINKD-DOI: 10.1109/TCSVT. 2003.815175, vol. 13, No. 7, Jul. 1, 2003 (Jul. 1, 2003). pp. 614-619, XP01122109.
- List P.: "Report of the Ad Hoc Committee on Loop Filter Improvement (VCEG-N08)" ITU Telecommunications Standardization Sector Study Group 16, VCEG-N008, [Online] Sep. 4, 2001, pp. 1-3, XP002347724 Santa Barbara, CA, USA, generated Aug. 8, 2001.
- Meier T. et al.: "Reduction of Blocking Artifacts in Image and Video Coding", IEEE Transactions on Circuits and Systems for Video Technology, vol. 9, No. 3, Apr. 1999; pp. 490-499.
- Park H. W. et al.: "A Postprocessing Method for Reducing Quantization Effects in Low Bit-Rate Moving Picture Coding", IEEE Transactions on Circuits and Systems for Video Technology, IEEE Inc. New York, US, vol. 9, No. 1, Feb. 1999, pp. 161-171.
- Suehring, Karsten, "Release of reference software TML 8.4", tml84changes.txt, Sep. 3, 2001, XP002606232, Retrieved from the Internet: URL: <http://wftp3.itu.int/av-arch/video-site/h26L/older.sub--tml/tml84chan-ges.txt> [retrieved on Oct. 20, 2010].
- Sun S. et al.: "Extended Spatial Scalability with Picture-Level Adaptation," ITU Study Group 16—Video Coding Experts Group—ISO/IEC MPEG & ITU-T VCEG(ISO/IEC JTC1/SC29/VVG11 and ITU-T SG16 Q6), No. JVT-0008, Apr. 13, 2005 (Apr. 13, 2005), XP030005956.
- Sun S. et al.: "Improved TML Loop Filter with Lower Complexity (VCEG-N17)" ITU Telecommunications Standardization Sector Study Group 16, VCEG-N17, [Online] Sep. 24, 2001, pp. 1-8, XP002347725 Santa Barbara, CA USA, generated Aug. 14, 2001.
- Sun S. et al.: "Loop Filter with Skip Mode (VCEG-M20)" ITU Telecommunications Standardization Sector Study Group 16, VCEG-M20, Apr. 2-4, 2001, pp. 1-8, XP002321426 Austin, Texas, USA, sections 1 + 2 with figure 1, generated Mar. 27, 2001.
- Sun S.: "CE2 Part 2: Deblocking filter for I.sub.—BL Blocks Spatial Scalable Video Coding", ITU Study Group 16—Video Coding Experts Group—ISO/IEC MPEG & ITU-T VCEG(ISO/IEC JTC1/SC29/WG11 and ITU-T SG16 Q6), No. JVT-P013r1, Jul. 28, 2005 (Jul. 28, 2005), XP030006055.
- Turkowski K.: "Filters for Common Resampling Tasks," Graphics Gems I, Academic Pres, Apple Computer, Apr. 1990.
- Video & JVT, Description of Core Experiments in SVC, International Organisation for Standardisation, Organisation International De Normalisation, Coding of Moving Pictures and Audio, ISO/IEC JTC1/SC29/WG11/N6898, Hong Kong, Jan. 2005.
- Video Coding Experts Group (Question 15) Eleventh Meeting: ITU—Telecommunications Standardization Sector, dated Oct. 25, 2000, 35 pages.
- European Search Report for European Application No. EP 02 00 6295, dated Apr. 20, 2005.
- Peter List, "Report of the AD Hoc Committee on Loop Filter Improvement (VCEG-N08)" ITU Telecommunications Standardization Sector Study Group 16, XX, XX, Sep. 4, 2001, pp. 1-3, XP002347724, p. 2, paragraph 4.5, Santa Barbara.

* cited by examiner

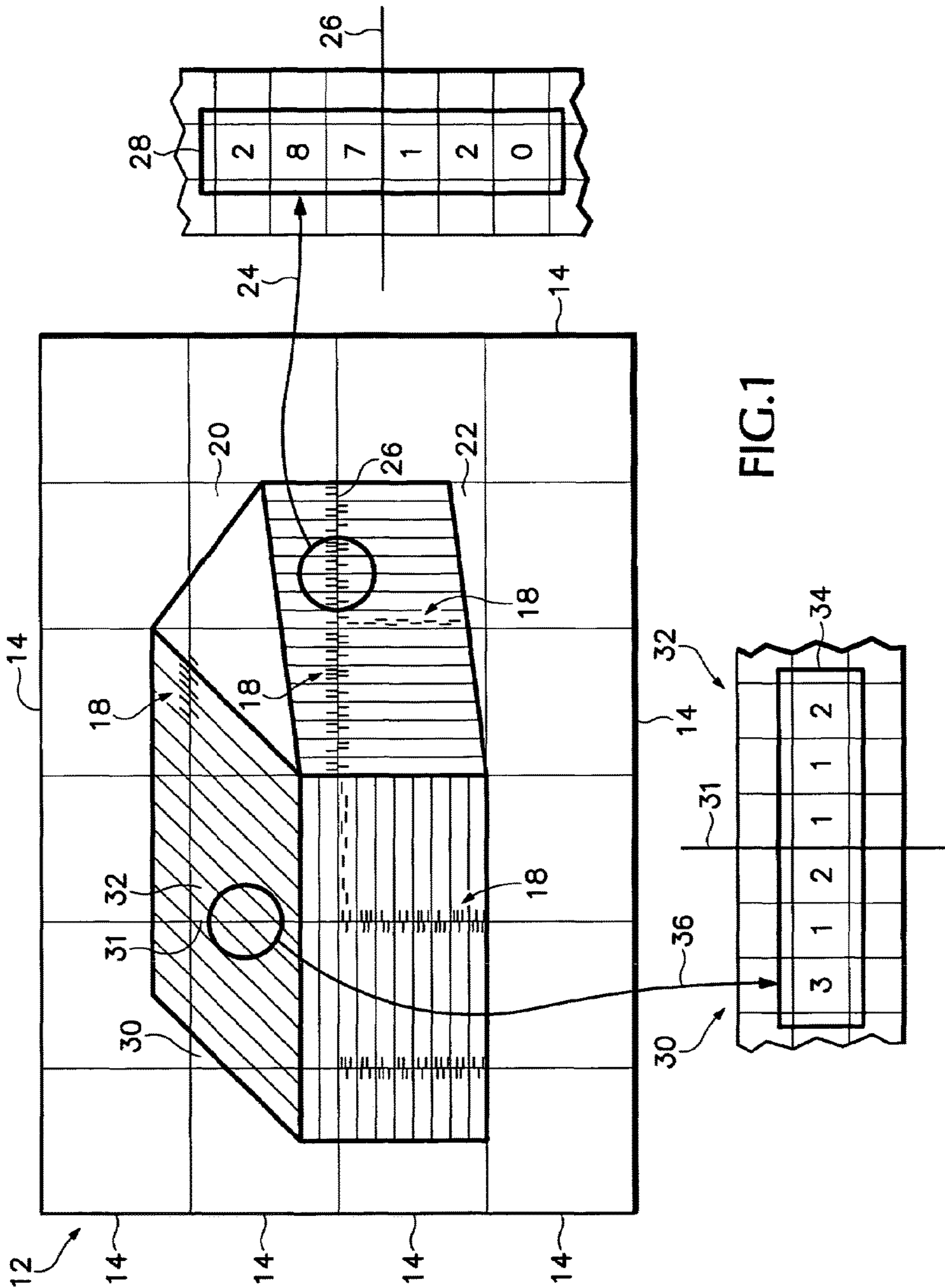

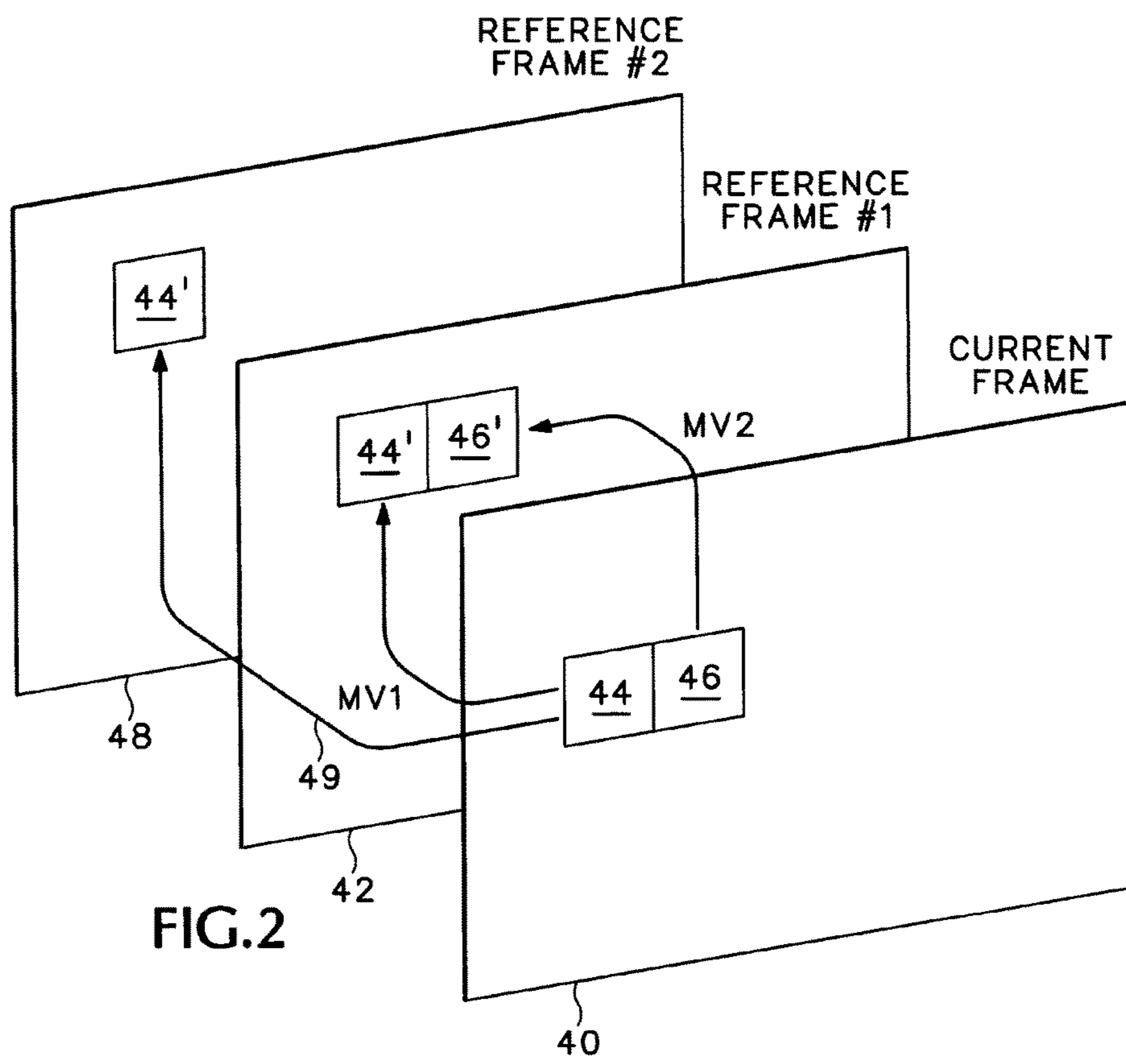

FIG.2

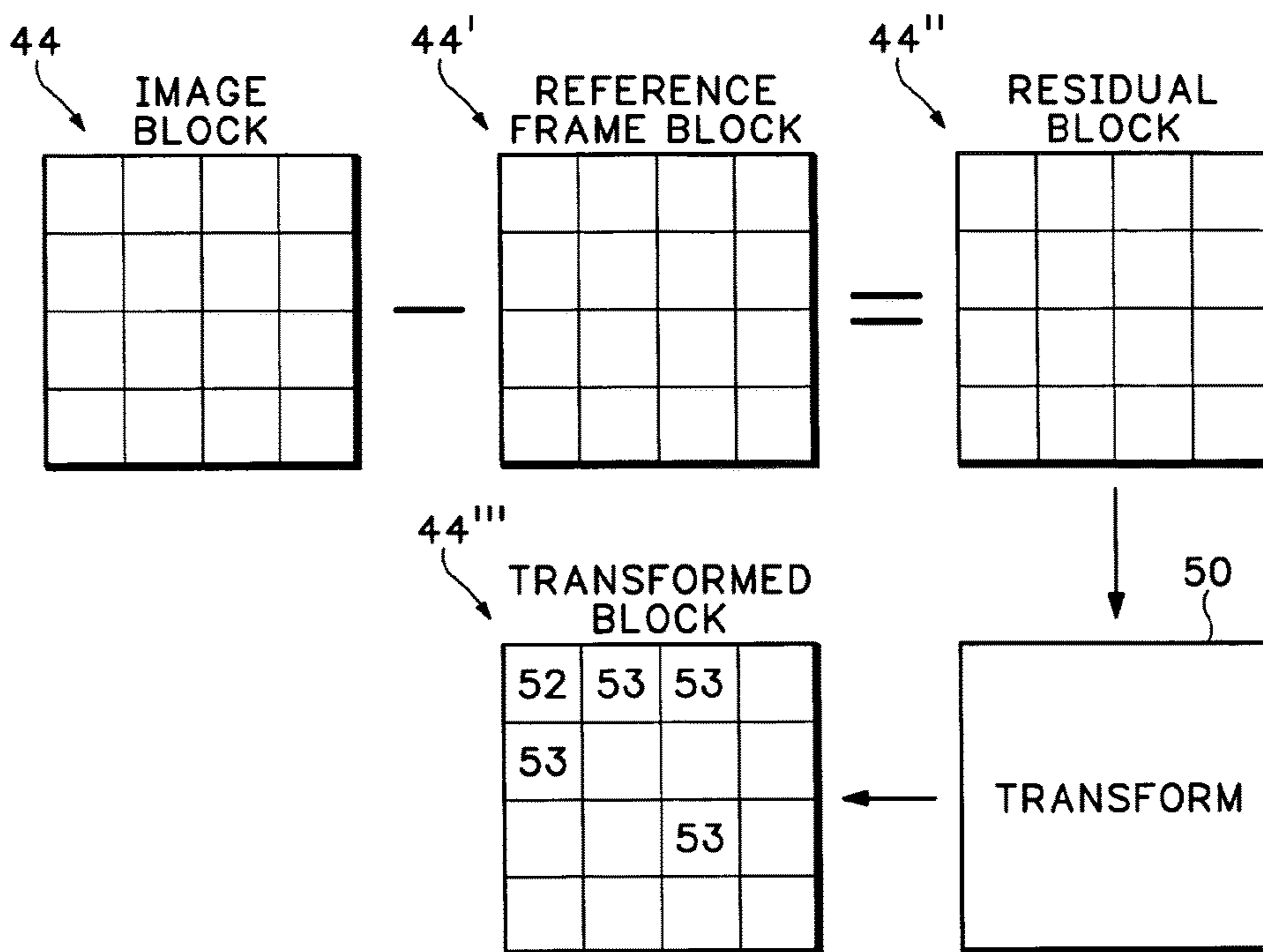

FIG.3

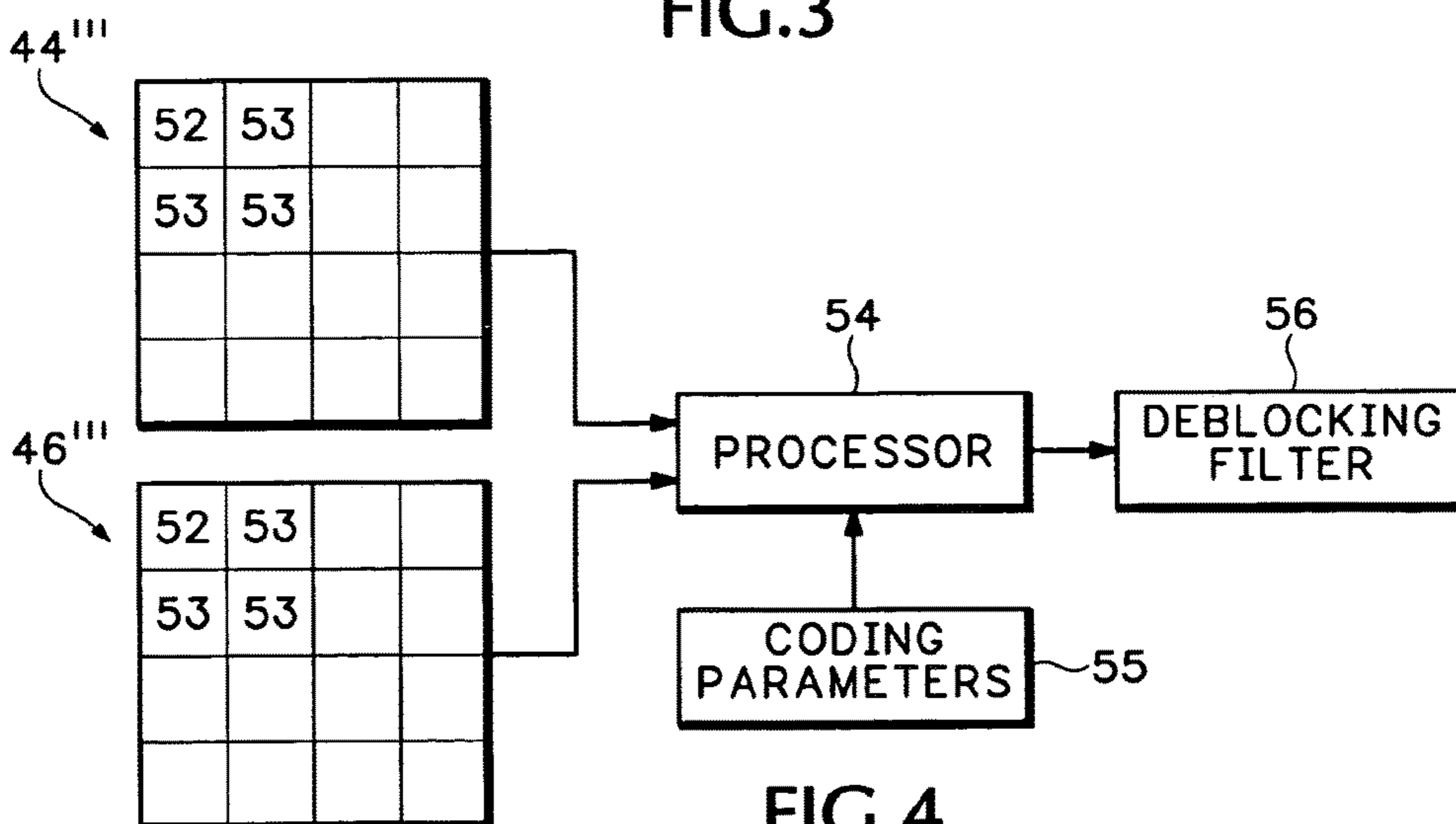

FIG.4

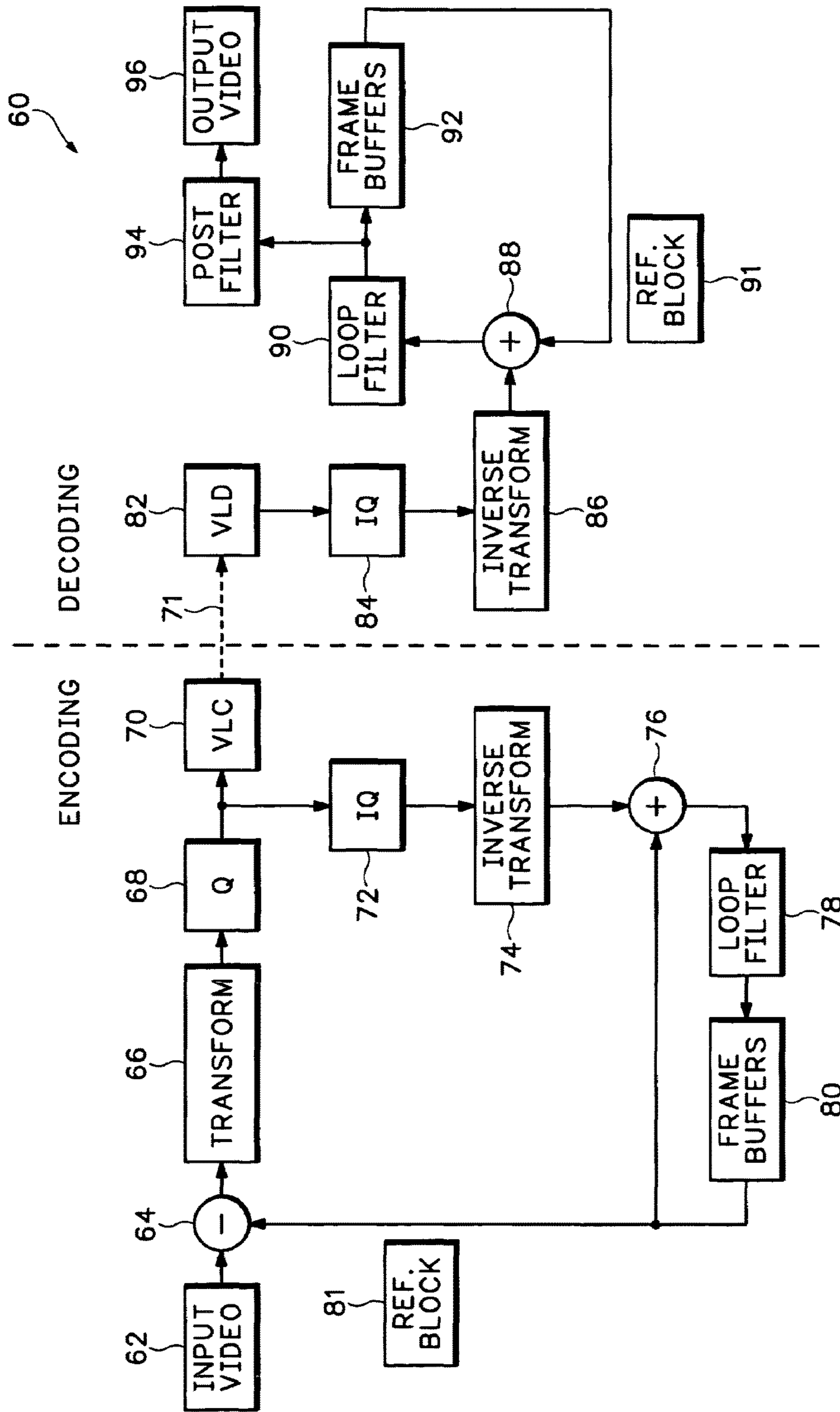

FIG.5

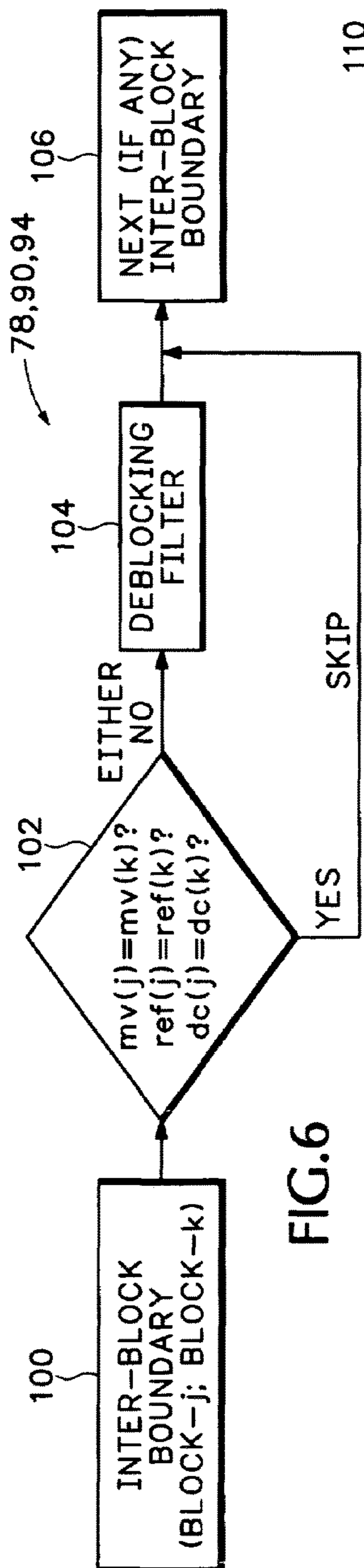

FIG.6

TABLE 1. COMPARISON BETWEEN TML AND THE PROPOSED LOOP FILTERING SCHEME

VIDEO SEQUENCE	QP	BITRATE (bps)		PSNR (Y)		PSNR (U)		PSNR (V)		NEW LOOP FILTER RELATIVE TIME SAVING
		TML	SLA	TML	SLA	TML	SLA	TML	SLA	
Akiyo_cif 300 FRAMES @ 30fps	25	33151	32346	34.050	34.161	38.934	39.042	40.300	40.369	63.0%
	30	22775	22295	30.797	30.920	36.610	36.964	38.680	38.771	68.2%
Foreman_cif 300 FRAMES @ 30fps	25	165115	162740	30.835	31.006	38.124	38.174	38.966	39.030	43.1%
	30	101357	100215	27.580	27.836	36.745	36.811	37.267	37.362	42.1%
Foreman_qcif 100 FRAMES @ 10fps	25	28681	28677	29.822	29.931	37.586	37.631	37.773	37.938	38.4%
	30	15999	15822	26.250	26.435	36.432	36.323	36.222	36.283	41.3%
Temple_cif 260 FRAMES @ 30fps	25	336200	329115	28.277	28.490	33.982	34.143	36.009	36.184	45.3%
	30	168133	159789	24.583	24.927	32.334	32.628	34.512	34.799	50.6%

FIG.7

**METHOD AND APPARATUS FOR
CONTROLLING LOOP FILTERING OR
POST FILTERING IN BLOCK BASED
MOTION COMPENSATED VIDEO
CODING**

Matter enclosed in heavy brackets [] appears in the original patent but forms no part of this reissue specification; matter printed in italics indicates the additions made by reissue; a claim printed with strikethrough indicates that the claim was canceled, disclaimed, or held invalid by a prior post-patent action or proceeding.

More than one reissue application has been filed for the reissue of U.S. Pat. No. 7,440,501. The reissue applications are: patent application Ser. No. 12/908,690, filed on Oct. 20, 2010, now reissued as Pat. No. RE43,628; patent application Ser. No. 13/495,944, filed on Jun. 13, 2012, now reissued as Pat. No. RE44,497; patent application Ser. No. 13/954,817, filed on Jul. 30, 2013, now reissued as Pat. No. RE45,250; patent application Ser. No. 14/512,165, filed on Oct. 10, 2014, now reissued as Pat. No. RE46,482; patent application Ser. No. 14/512,067, filed on Oct. 10, 2014, now reissued as Pat. No. RE46,491; patent application Ser. No. 15/651,868, filed on Jul. 17, 2017; and patent application Ser. No. 15/651,879 (the present application), filed on Jul. 17, 2017.

This application is a continuation reissue application of application Ser. No. 14/512,165, filed on Oct. 10, 2014, and is a reissue of U.S. Pat. No. 7,440,501. Patent application Ser. No. 14/512,165 is a continuation reissue application of application Ser. No. 13/954,817 filed Jul. 30, 2013 (now U.S. Pat. No. RE45,250), and is a reissue of U.S. Pat. No. 7,440,501. Patent application Ser. No. 13/954,817 is a continuation reissue application of application Ser. No. 13/495,944 filed on Jun. 13, 2012 (now U.S. Pat. No. RE44,497), and a reissue of U.S. Pat. No. 7,440,501. Patent application Ser. No. 13/495,944 is a continuation reissue application of application Ser. No. 12/908,690, filed on Oct. 20, 2010 (now U.S. Pat. No. RE43,628), and a reissue of U.S. Pat. No. 7,440,501. Patent application Ser. No. 12/908,690 is a reissue of U.S. Pat. No. 7,440,501, which was filed as application Ser. No. 11/105,729 on Apr. 13, 2005, and is a divisional [based on prior] of U.S. application Ser. No. 09/817,701, filed Mar. 26, 2001, now U.S. Pat. No. 6,931,063.

BACKGROUND

Block based motion compensated video coding is used in many video compression standards such as H.261, H.263, H263+, MPEG-1, MPEG-2, and H26L. The lossy compression process can create visual artifacts in the decoded images, referred to as image artifacts. Blocking artifacts occur along the block boundaries in an image and are caused by the coarse quantization of transform coefficients.

Image filtering techniques can be used to reduce artifacts in reconstructed images. Reconstructed images are the images produced after being inverse transformed and decoded. The rule of thumb in these techniques is that image edges should be preserved while the rest of the image is smoothed. Low pass filters are carefully chosen based on the characteristic of a particular pixel or set of pixels surrounding the image edges.

Non-correlated image pixels that extend across image block boundaries are specifically filtered to reduce blocking artifacts. However, this filtering can introduce blurring artifacts into the image. If there are little or no blocking artifacts between adjacent blocks, then low pass filtering needlessly incorporates blurring into the image while at the same time wasting processing resources.

The present invention addresses this and other problems associated with the prior art.

SUMMARY OF THE INVENTION

Adjacent blocks are identified in an image. Coding parameters for the adjacent blocks are identified. Deblock filtering between the identified adjacent blocks is skipped if the coding parameters for the identified adjacent blocks are similar and not skipped if the coding parameters for the identified adjacent blocks are substantially different.

BRIEF DESCRIPTION OF THE DRAWINGS

FIG. 1 is a diagram showing how deblock filtering is selectively skipped according to similarities between adjacent image blocks.

FIG. 2 is a diagram showing two adjacent image blocks having similar motion vectors.

FIG. 3 is a diagram showing how transform coefficients are identified for one of the image blocks.

FIG. 4 is a diagram showing how residual transform coefficients are compared between two adjacent image blocks.

FIG. 5 is a block diagram showing how the video image is encoded and decoded.

FIG. 6 is a block diagram showing how deblock filtering is selectively skipped in a codec.

FIG. 7 shows a table containing the results from selective deblock filter skipping.

DETAILED DESCRIPTION

In conventional filtering methods, filter processing only considers a single reconstructed image frame at a time. The motion-vector information available at both the encoder and decoder is not used. If two adjacent blocks share the same motion vector with respect to the same reference image frame, (for a multiple reference frames system) there may be no significant difference between the image residuals of each block. The block boundary of these two adjacent blocks may have been filtered in the reference frame and should therefore not be filtered again for the current frame. If a deblock filter is used without considering this motion-vector information, the conventional filtering process might filter the same boundary again and again from frame to frame. This unnecessary filtering not only causes unnecessary blurring but also results in extra filter computations.

FIG. 1 shows an image **12** that selectively filters block artifacts according to similarities between image blocks. The image **12** includes multiple image blocks **14** that are each individually encoded before being stored, transmitted, etc. The borders between some of the blocks **14** include blocking artifacts **18**. Blocking artifacts are any image discontinuities between blocks **14** that may be created by the encoding process. A low pass filter is used to reduce the blocking artifacts that exist at the borders of adjacent image blocks.

For example, blocking artifacts **24** exist between blocks **20** and **22**. A low pass filter is used at the border **26** between blocks **20** and **22** to remove or reduce the blocking artifacts

24. The low pass filter in one example selects a group of pixels **28** from both sides of the border **26**. An average pixel value is derived from the group of pixels **28**. Then each individual pixel is compared to the average pixel value. Any pixels in group **28** outside of a predetermined range of the average pixel value is then replaced with the average pixel value.

As described above, if there are little or no blocking artifacts **24** between the adjacent pixels, then the group of pixels **28** may be needlessly filtered causing blurring in the image and wasting processing resources. A skip mode filtering scheme uses the motion estimation and compensation information for adjacent image blocks. If the motion estimation and compensation information is similar, deblock filtering is skipped. This not only avoids unnecessary image blurring but also significantly reduces the required number of filtering operations.

For example, it is determined during the encoding process that adjacent image blocks **30** and **32** have similar coding parameters. Accordingly, deblock filtering is skipped for the groups of pixels **34** that extend across the border **31** between adjacent blocks **30** and **32**. Skip mode filtering can be used for any horizontal or vertical boundary between any adjacent blocks in image **12**.

FIG. **2** shows reference frames **42** and **48** and a current frame **40** that is currently being encoded or decoded. Coding parameters for blocks **44** and **46** are compared to determine whether deblock filtering should be skipped between the two adjacent blocks **44** and **46**. One encoding parameter that is compared is the Motion Vectors (MV) for the blocks **44** and **46**.

The motion vector MV1 points from block **44** in current image frame **40** to an associated block **44'** in the reference image **42**. The motion vector MV2 points from block **46** in current image frame **40** to an associated block **46'** in reference frame **42**. Skip mode filtering checks to see if the motion vectors MV1 and MV2 point to adjacent blocks in the same reference frame **42**. If the motion vectors point to adjacent blocks in the reference frame (MV1=MV2), then deblock filtering is skipped. This motion vector information may be used along with other coding information to decide whether to skip deblock filtering between the two image blocks **44** and **46**.

More than one reference frame may be used during the encoding and decoding process. For example, there may be another reference frame **48**. The adjacent blocks **44** and **46** may have motion vectors pointing to different reference frames. In one embodiment, the decision to skip deblock filtering depends on whether the motion vectors for the two adjacent blocks point to the same reference frame. For example, image block **44** may have a motion vector **49** pointing to reference frame **48** and image block **46** may have the motion vector MV2 pointing to reference frame **42**. Deblock filtering is not skipped in this example because the motion vectors **49** and MV2 point to different reference frames.

FIG. **3** shows another coding parameter that may be used to decide whether or not to skip deblock filtering. The image block **44** from image frame **40** is compared with reference block **44'** from the reference frame **42** pointed to by the motion vector MV1 as previously shown in FIG. **2**. A residual block **44''** is output from the comparison between image block **44** and reference block **44'**. A transform **50** is performed on the residual block **44''** creating a transformed block **44'''** of transform coefficients. In one example, the

transform **50** is a Discrete Cosine Transform. The transformed block **44'''** includes a D.C. component **52** and A.C. components **53**.

The D.C. component **52** refers to a lowest frequency transform coefficient in image block **44**. For example, the coefficient that represents the average energy in the image block **44**. The A.C. components **53** refer to the transform coefficients that represent the higher frequency components in the image block **44**. For example, the transform coefficients that represent the large energy differences between pixels in the image block **44**.

FIG. **4** shows the transformed residual blocks **44'''** and **46'''**. The D.C. components **52** from the two transformed blocks **44'''** and **46'''** are compared in processor **54**. If the D.C. components are the same or within some range of each other, the processor **54** notifies a deblock filter operation **56** to skip deblock filtering between the border of the two adjacent blocks **44** and **46**. If the D.C. components **52** are not similar, then no skip notification is initiated and the border between blocks **44** and **46** is deblock filtered.

In one embodiment, skip mode filtering is incorporated into the Telecommunications Sector of the International Telecommunication Union (ITU-T) proposed H.26L encoding scheme. The H.26L scheme only uses 4x4 integer Discrete Cosine Transform (DCT) blocks. Here, only the D.C. component of the two adjacent blocks may be checked. However some limited low frequency A.C. coefficients could also be checked when the image blocks are bigger sizes, such as 8x8 or 16x16 blocks. For example, the upper D.C. component **52** and the three lower frequency A.C. transform coefficients **53** for block **44'''** may be compared with the upper D.C. component **52** and three lower frequency A.C. transform coefficients **53** for block **46'''**. Different combinations of D.C. and/or low frequency A.C. transform coefficients can be used to identify the relative similarity between the two adjacent blocks **44** and **46**.

The processor **54** can also receive other coding parameters **55** that are generated during the coding process. These coding parameters include the motion vectors and reference frame information for the adjacent blocks **44** and **46** as described above. The processor **54** uses all of these coding parameters to determine whether or not to skip deblock filtering between adjacent image blocks **44** and **46**. Other encoding and transform functions performed on the image may be carried out in the same processor **54** or in a different processing circuit. In the case where all or most of the coding is done in the same processor, the skip mode is simply enabled by setting a skip parameter in the filtering routine.

FIG. **5** shows how skip mode filtering is used in a block-based motion-compensated Coder-Decoder (Codec) **60**. The codec **60** is used for inter-frame coding. An input video block from the current frame is fed from box **62** into a comparator **64**. The output of a frame buffering box **80** generates a reference block **81** according to the estimated motion vector (and possible reference frame number). The difference between the input video block and the reference block **81** is transformed in box **66** and then quantized in box **68**. The quantized transform block is encoded by a Variable Length Coder (VLC) in box **70** and then transmitted, stored, etc.

The encoding section of the codec **60** reconstructs the transformed and quantized image by first Inverse Quantizing (IQ) the transformed image in box **72**. The inverse quantized image is then inverse transformed in box **74** to generate a reconstructed residual image. This reconstructed residual block is then added in box **76** to the reference block **81** to

generate a reconstructed image block. Generally the reconstructed image is loop filtered in box 78 to reduce blocking artifacts caused by the quantization and transform process. The filtered image is then buffered in box 80 to form reference frames. The frame buffering in box 80 uses the reconstructed reference frames for motion estimation and compensation. The reference block 81 is compared to the input video block in comparator 64. An encoded image is output at node 71 from the encoding section and is then either stored or transmitted.

In a decoder portion of the codec 60, a variable length decoder (VLD) decodes the encoded image in box 82. The decoded image is inverse quantized in box 84 and inverse transformed in box 86. The reconstructed residual image from box 86 is added in the summing box 88 to the reference block 91 before being loop filtered in box 90 to reduce blocking artifacts and buffered in box 92 as reference frames. The reference block 91 is generated from box 92 according to the received motion vector information. The loop filtered output from box 90 can optionally be post filtered in box 94 to further reduce image artifacts before being displayed as a video image in box 96. The skip mode filtering scheme can be performed in any combination of the filtering functions in boxes 78, 90 and 94.

The motion estimation and compensation information available during video coding are used to determine when to skip deblock filtering in boxes 78, 90 and/or 94. Since these coding parameters are already generated during the encoding and decoding process, there are no additional coding parameters that have to be generated or transmitted specially for skip mode filtering.

FIG. 6 shows is further detail how skip mode filtering is used in the filters 78, 90, and/or 94 in the encoder and decoder in FIG. 5. The interblock boundary between any two adjacent blocks "j" and "k" is first identified in box 100. The two blocks may be horizontally or vertically adjacent in the image frame. Decision box 102 compares the motion vector $mv(j)$ for block j with the motion vector $mv(k)$ for block k. It is first determined whether the two adjacent blocks j and k have the same motion vector pointing to the same reference frame. In other words, the motion vectors for the adjacent blocks point to adjacent blocks ($mv(j)=mv(k)$) in the same reference frame ($ref(j)=ref(k)$).

It is then determined whether the residual coefficients for the two adjacent blocks are similar. If there is no significant difference between the image residuals of the adjacent blocks, for example, the two blocks j and k have the same of similar D.C. component ($dc(j)=dc(k)$), then the deblock filtering process in box 104 is skipped. Skip mode filtering then moves to the next interblock boundary in box 106 and conducts the next comparison in decision box 102. Skip mode filtering can be performed for both horizontally adjacent blocks and vertically adjacent blocks.

In one embodiment, only the reference frame and motion vector information for the adjacent image blocks are used to determine block skipping. In another embodiment, only the D.C. and/or A.C. residual coefficients are used to determine block skipping. In another embodiment, the motion vector, reference frame and residual coefficients are all used to determine block skipping.

The skip mode filtering scheme can be applied to spatially sub-sampled chrominance channels. For example in a case with 4:2:0 color format sequences, skip mode filtering for block boundaries may only rely on the equality of motion vectors and D.C. components for the luminance component of the image. If the motion vectors and the D.C. components are the same, deblock filtering is skipped for both the

luminance and chrominance components of the adjacent image blocks. In another embodiment, the motion vectors and the D.C. components are considered separately for each luminance and chrominance component of the adjacent blocks. In this case, a luminance or chrominance component for adjacent blocks may be deblock filtered while the other luminance or chrominance components for the same adjacent blocks are not deblock filtered.

FIG. 7 includes a table 110 showing the results of skip mode filtering using a ITU-TH.26L Testing Model-Long TML5.0. Table 110 compares the results of the TML filtering standard with skip mode filtering as described above. Encoding results using skip mode filtering are shown in table 110 under the heading SLA.

There were four images that were tested, Akiyo_cif for 300 frames at 30 Frames Per Second (fps), Foreman_cif for 300 frames at 30 fps, Foreman_qcif for 100 frames at 10 fps, and Tempete_cif for 260 frames at 30 fps. Quantization Parameters (QP) of 25 and 30 were used. The results show no significant visual quality degradation with the skip mode filtering. The Picture Signal to Noise Ratio (PSNR) for the images stays approximately the same for the luminance Y and chrominance U and V channels. However, skip mode filtering provides time savings of 40-70 percent.

Skip mode filtering can be used with any system that encodes or decodes multiple image frames. For example, DVD players, video recorders, or any system that transmits image data over a communications channel, such as over television channels or over the Internet.

The skip mode filtering described above can be implemented with dedicated processor systems, micro controllers, programmable logic devices, or microprocessors that perform some or all of the operations. Some of the operations described above may be implemented in software and other operations may be implemented in hardware.

For the sake of convenience, the operations are described as various interconnected functional blocks or distinct software modules. This is not necessary, however, and there may be cases where these functional blocks or modules are equivalently aggregated into a single logic device, program or operation with unclear boundaries. In any event, the functional blocks and software modules or described features can be implemented by themselves, or in combination with other operations in either hardware or software.

Having described and illustrated the principles of the invention in a preferred embodiment thereof, it should be apparent that the invention may be modified in arrangement and detail without departing from such principles. Claim is made to all modifications and variation coming within the spirit and scope of the following claims.

The invention claimed is:

- [1. A method for encoding an image, comprising:
 - identifying spatially adjacent blocks in a same frame of the image;
 - identifying transform coefficients for the spatially adjacent blocks in the same frame of the image;
 - comparing the transform coefficients between the spatially adjacent blocks in the same frame of the image;
 - skipping deblock filtering for removing image residuals caused by encoding the image when the comparison indicates that the spatially adjacent blocks in the same frame of the image have same or similar transform coefficients; and
 - deblock filtering to remove image residuals between the identified spatially adjacent blocks when the comparison between the transform coefficients for the identified spatially adjacent blocks in the same frame of the

7

image indicate that the spatially adjacent blocks do not have the same or similar transform coefficients.]

[2. A method according to claim 1 including: identifying D.C. components in the transform coefficients;

comparing the D.C. components for the spatially adjacent blocks with each other; and

skipping deblock filtering between the spatially adjacent blocks when the D.C. components for the compared spatially adjacent blocks have same or similar values relative to each other.]

[3. A method according to claim 1 including: identifying both D.C. and A.C. components in the transform coefficients;

comparing the D.C. components for adjacent blocks and A.C. components for adjacent blocks; and

skipping deblock filtering between the adjacent blocks when both the D.C. components are the same or similar and the A.C. components are the same or similar.]

[4. A method according to claim 1 including controlling deblock filtering for a loop filter in an image coder.]

[5. A method according to claim 1 including controlling deblock filtering in one or both of a loop filter and a post filter in an image decoder.]

[6. A method according to claim 1 including: identifying similarities between coding parameters in a luminance channel of the adjacent blocks; and controlling deblock filtering for both the luminance channel and a chrominance channel in the image according to identified similarities in the luminance channel.]

[7. A method according to claim 1 including selectively skipping deblock filtering in any one of a H.261, H.263, H263+, MPEG-1, MPEG-2, or H26L encoding standard according to encoding parameter similarities between adjacent image blocks.]

[8. An encoder for encoding an image, comprising: a processor adapted to:

compare blocks in a same image frame with reference frames;

transform a result of the comparison between the reference frames and the blocks in the image frame into transformed blocks having transform coefficients;

compare the similarities between the transform coefficients for spatially adjacent transformed blocks within the same image frame; and

skipping deblock filtering between spatially adjacent transformed blocks in the image that have the same or similar transform coefficients.]

[9. An encoder according to claim 8 wherein the processor is adapted to

identify motion vectors and associated reference frames for the adjacent blocks and skip deblock filtering between the spatially adjacent blocks according to the identified motion vectors and reference frames.]

[10. An encoder according to claim 8 wherein the processor is adapted to

identify residual coefficients for the spatially adjacent blocks and skip deblock filtering according to the identified residual coefficients.]

[11. An encoder according to claim 8 wherein the processor is adapted to skip deblock filtering according to both D.C. and A.C. components in the residual coefficients.]

[12. A decoder for decoding an encoded image, comprising:

a processor adapted to identify spatially adjacent blocks in the encoded image;

8

identify coding parameters including D.C. coefficients for the spatially adjacent blocks within a same encoded image frame;

compare the identified D.C. coefficients between the identified spatially adjacent blocks; and

enable or disable filtering of blocking artifacts between the spatially adjacent blocks according to the comparison of the D.C. coefficients between the spatially adjacent blocks within the same encoded image frame.]

[13. A decoder according to claim 12 wherein the processor is adapted to identify both D.C. coefficients and A.C. coefficients for the spatially adjacent blocks within a same encoded image frame;

compare the identified D.C. coefficients between the identified spatially adjacent blocks and compare the identified A.C. coefficients between the identified spatially adjacent blocks; and

enable or disable filtering of blocking artifacts between the spatially adjacent blocks according to the comparison of the D.C. coefficients between the adjacent blocks within the same encoded image frame and according to the comparison of the A.C. coefficients between the adjacent blocks within the same encoded image frame.]

[14. A decoder according to claim 12 wherein the processor is adapted to

identify residual coefficients for the spatially adjacent blocks and skip deblock filtering between the spatially adjacent blocks according to the identified residual coefficients.]

[15. A decoder according to claim 12 wherein the processor is adapted to

inverse transform the encoded image, compare blocks in the inverse transformed encoded image with reference frames, generate a reconstructed image from the comparison between the inverse transformed encoded image and the reference frame, and skip deblock filtering between spatially adjacent blocks in the reconstructed image according to the coding parameters for the spatially adjacent blocks.]

[16. A decoder according to claim 15 wherein the coding parameters include transform coefficients, motion vectors, and reference frame information and the processor skips deblock filtering when the transform coefficients, motion vectors, and reference frame information for the spatially adjacent blocks are the same or similar.]

[17. A decoder according to claim 12 wherein the processor is adapted to

skip deblock filtering in one or both of a loop filter and a post filter.]

18. An image decoding method, comprising: storing reference images for an image to be decoded, the stored reference images being for motion compensation prediction of the image to be decoded;

obtaining a reference block from the stored reference images according to a motion vector;

inverse quantizing and inverse transforming an output of a variable length decoder to obtain a decoded difference block;

decoding an image from the reference block and the decoded difference block;

generating a reconstructed image based on the decoding; and

judging whether or not to execute deblock filtering for each boundary between adjacent blocks in the reconstructed image with respect to each of a luminance channel and a chrominance channel for the adjacent blocks, wherein

*the judging includes determining, with respect to one of
the luminance channel or the chrominance channel
for the adjacent blocks, whether or not motion vec-
tors of the adjacent blocks are equal to each other as
well as whether or not the motion vectors of the 5
adjacent blocks point to the same reference image,
and*

*in response to determining that the motion vectors of
the adjacent blocks are not equal to each other and
do not point to the same reference image, executing 10
deblock filtering for a boundary of the adjacent
blocks in the reconstructed image corresponding to
the luminance channel and a boundary of the adja-
cent blocks in the reconstructed image correspond-
ing to the chrominance channel. 15*

* * * * *