

US00RE46981E

(19) **United States**
(12) **Reissued Patent**
Neal et al.

(10) **Patent Number:** **US RE46,981 E**
(45) **Date of Reissued Patent:** ***Aug. 7, 2018**

(54) **APPARATUS FOR MODIFYING ENGINE OIL COOLING SYSTEM**

(58) **Field of Classification Search**
CPC F01M 5/002; F01M 11/03; F01M 1/10;
F01M 5/021; F01M 2001/1092;

(71) Applicant: **Neal Technologies, Inc.**, Mesa, AZ
(US)

(Continued)

(72) Inventors: **Gene Neal**, Phoenix, AZ (US);
Kennieth Neal, Mesa, AZ (US)

(56) **References Cited**

U.S. PATENT DOCUMENTS

(73) Assignee: **Neal Technologies, Inc.**, Mesa, AZ
(US)

3,561,417 A 2/1971 Downey
5,029,636 A * 7/1991 Kadle F28F 3/027
138/38

(*) Notice: This patent is subject to a terminal disclaimer.

(Continued)

OTHER PUBLICATIONS

(21) Appl. No.: **15/454,577**

Web Documents www.Speed4Speed.com.

(22) Filed: **Aug. 4, 2017**

(Continued)

Related U.S. Patent Documents

Reissue of:

(64) Patent No.: **9,453,454**
Issued: **Sep. 27, 2016**
Appl. No.: **14/591,524**
Filed: **Jan. 7, 2015**

Primary Examiner — William Doerrler
(74) *Attorney, Agent, or Firm* — Hartman Titus PLC;
John D. Titus

U.S. Applications:

(63) Continuation of application No. 14/087,265, filed on
Nov. 22, 2013, now Pat. No. 8,944,023, which is a
(Continued)

(57) **ABSTRACT**

A method of modifying the oil cooling system of a diesel engine includes the steps of removing the original equipment liquid-to-liquid heat exchanger and installing a manifold having a configuration adapted to match the mounting configuration of the oil passages of the original equipment liquid-to-liquid heat exchanger. The manifold has an oil outlet port directed to a remotely mounted oil cooler. The manifold also has a water passage having a configuration that is adapted to match the mounting configuration of the water passages of the original equipment liquid-to-liquid heat exchanger. The water passage causes the entirety of the flow of water to be discharged back to the water cooling system of the engine where it is circulated by the water pump through the water cooling passages in the engine.

(51) **Int. Cl.**
F01M 5/00 (2006.01)
F01M 5/02 (2006.01)
(Continued)

(52) **U.S. Cl.**
CPC **F01M 5/002** (2013.01); **F01M 1/10**
(2013.01); **F01M 5/021** (2013.01); **F01M**
11/03 (2013.01);
(Continued)

10 Claims, 4 Drawing Sheets

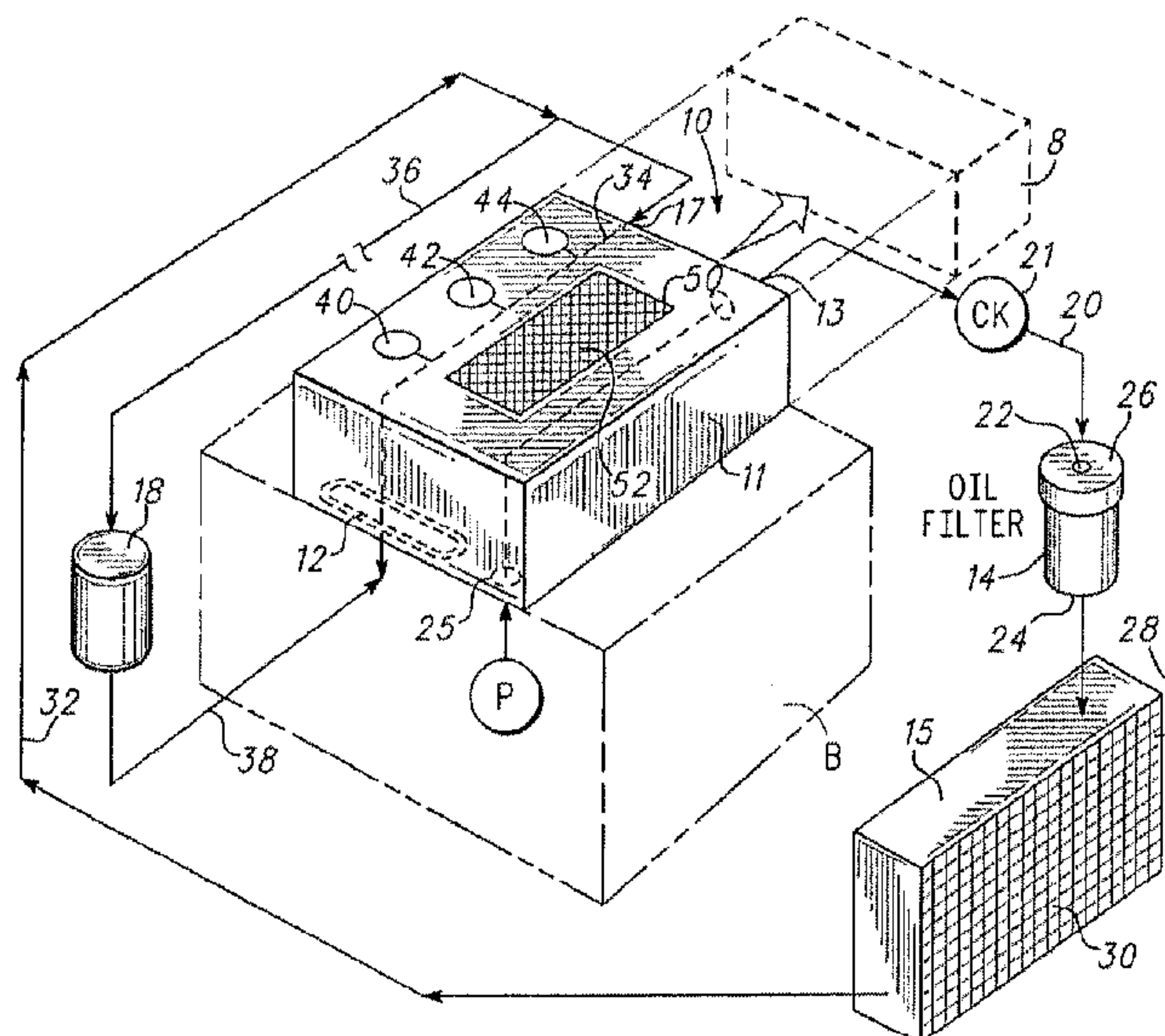

Related U.S. Application Data

continuation of application No. 13/905,660, filed on May 30, 2013, now Pat. No. 8,635,771, which is a continuation of application No. 13/746,709, filed on Jan. 22, 2013, now Pat. No. 8,505,512, which is a continuation of application No. 12/804,474, filed on Jul. 22, 2010, now Pat. No. 8,375,917.

(60) Provisional application No. 61/271,719, filed on Jul. 23, 2009.

(51) **Int. Cl.**

F01M 1/10 (2006.01)
F01M 11/03 (2006.01)
F01P 3/20 (2006.01)
F01P 5/10 (2006.01)
F01P 11/12 (2006.01)
F01P 11/08 (2006.01)

(52) **U.S. Cl.**

CPC *F01P 3/20* (2013.01); *F01P 5/10* (2013.01);
F01P 11/08 (2013.01); *F01P 11/12* (2013.01);
F01M 2001/1092 (2013.01); *F01M 2011/033*
(2013.01); *F01P 2060/04* (2013.01); *Y10T*
29/49231 (2015.01); *Y10T 29/49233* (2015.01)

(58) **Field of Classification Search**

CPC *F01M 2001/033*; *F01P 5/10*; *F01P 11/12*;
F01P 11/08; *F01P 3/20*; *F01P 2060/04*;
Y10T 29/49231; *Y10T 29/49233*
See application file for complete search history.

(56) **References Cited**

U.S. PATENT DOCUMENTS

5,291,969 A 3/1994 Diederich

5,507,206 A * 4/1996 Solski B25B 25/005
29/252
5,647,306 A * 7/1997 Pateman F01M 5/002
123/196 A
5,901,808 A * 5/1999 Swenson B62J 11/00
180/229
5,964,283 A 10/1999 Pavlin
6,026,894 A * 2/2000 Bachinger F28D 9/0037
165/165
6,536,381 B2 * 3/2003 Langervik F01P 3/20
123/196 AB
6,634,323 B2 * 10/2003 Vaudry F01P 5/10
123/41.1
7,207,298 B2 * 4/2007 Lee F01P 7/165
123/41.05
7,216,609 B2 * 5/2007 Theorell F01P 3/2207
123/41.29
7,267,084 B2 * 9/2007 Lutze F01P 3/20
123/41.02
8,944,023 B2 * 2/2015 Neal F01M 5/002
123/196 AB
2007/0137607 A1 6/2007 Ledbetter

OTHER PUBLICATIONS

Web Documents www.Mini-Madness.com.

Web Documents www.Liberatorperformanceinc.com.

Web Documents www.ford-trucks.com/forum.

Web Documents BAT, Inc.

Web Documents www.dieselplace.com.

* cited by examiner

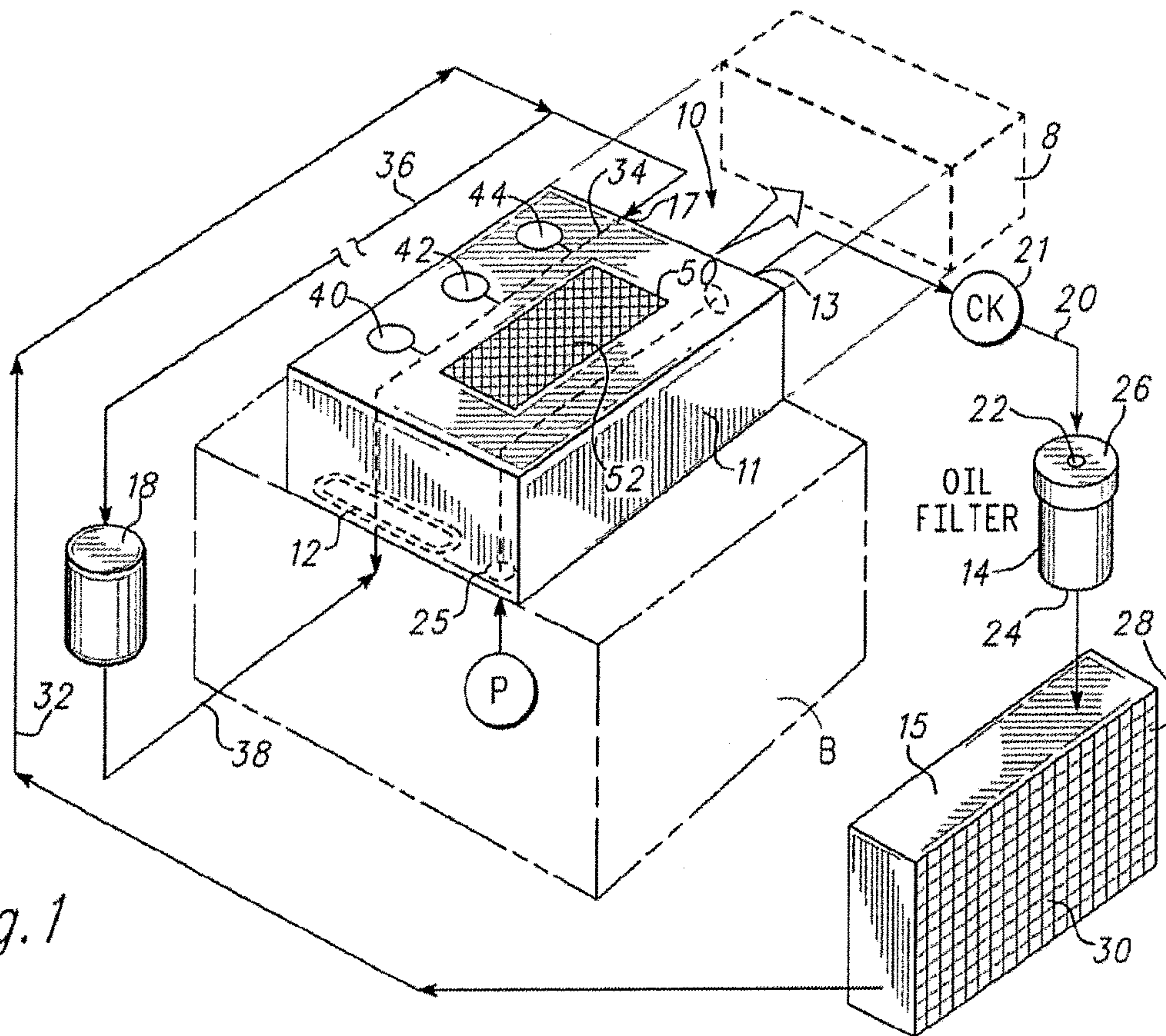

Fig. 1

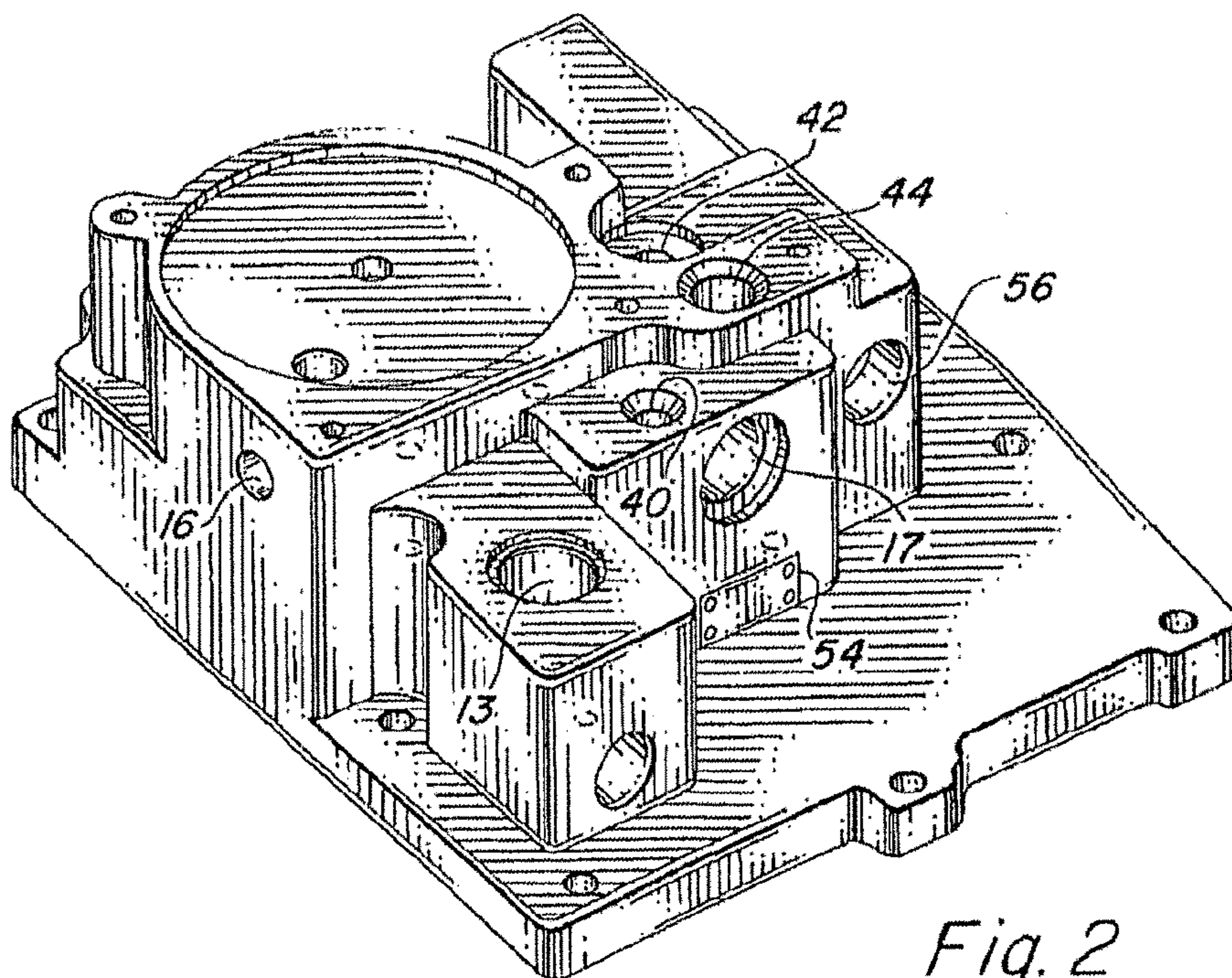

Fig. 2

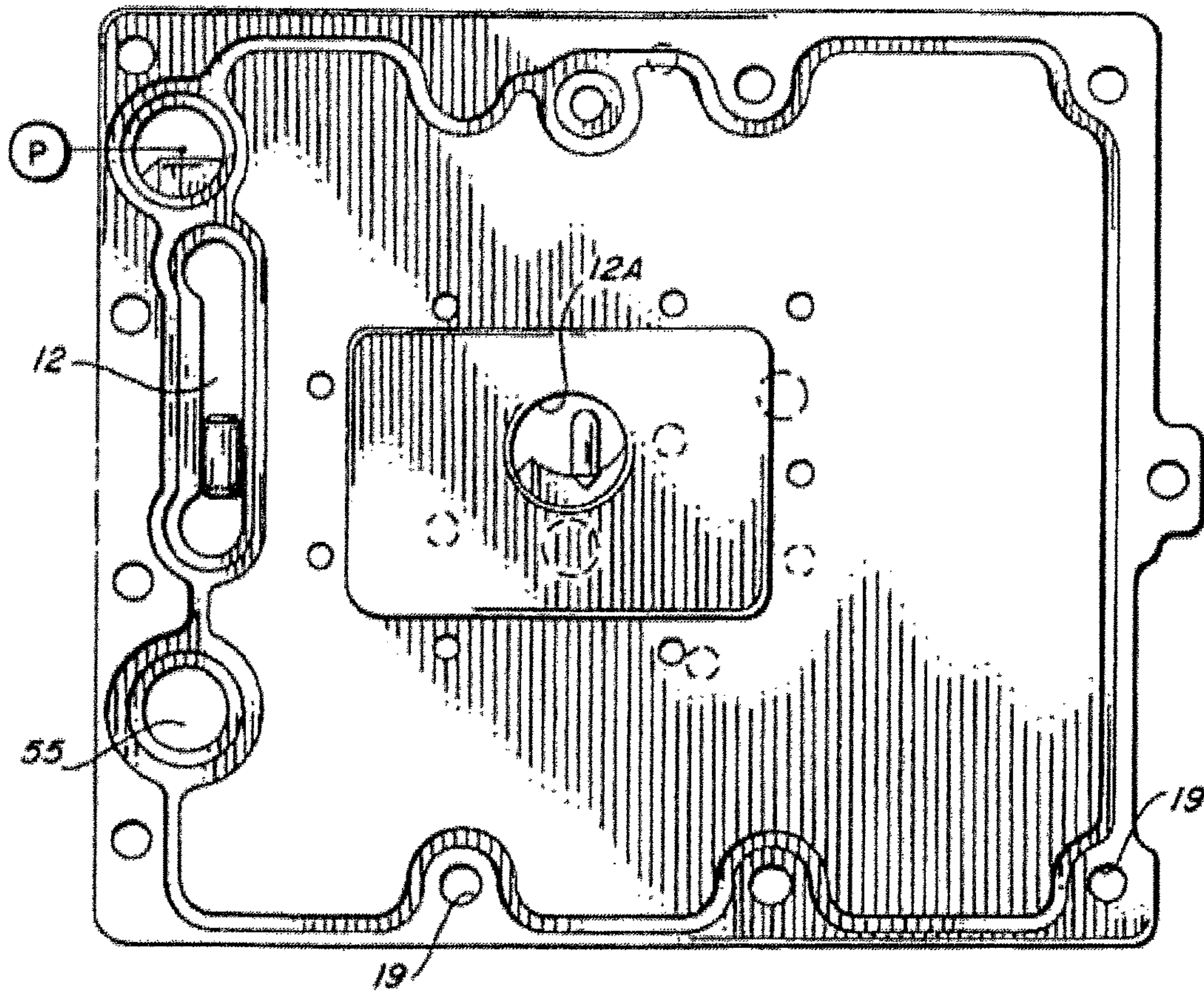

Fig. 3

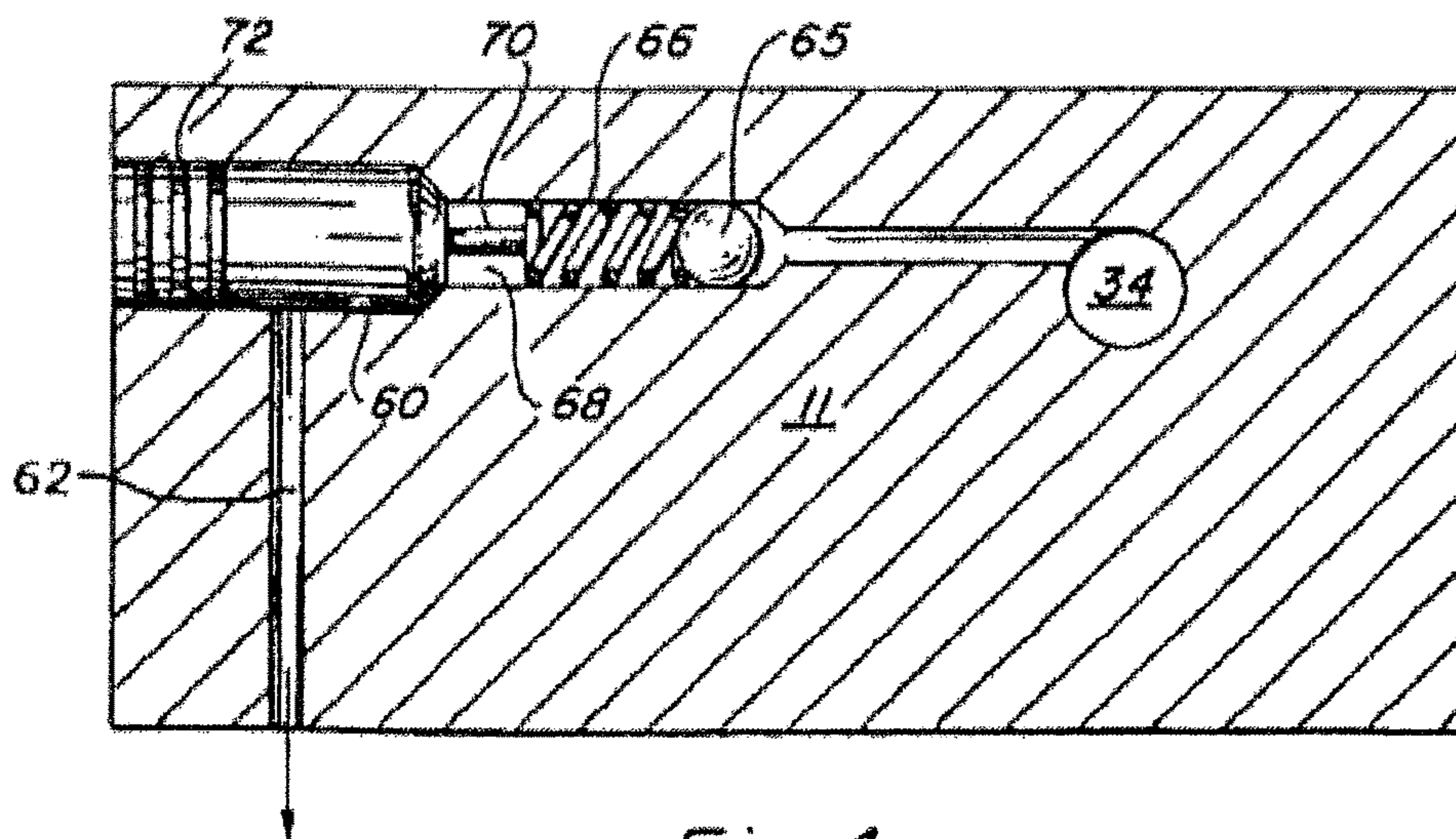

Fig. 4

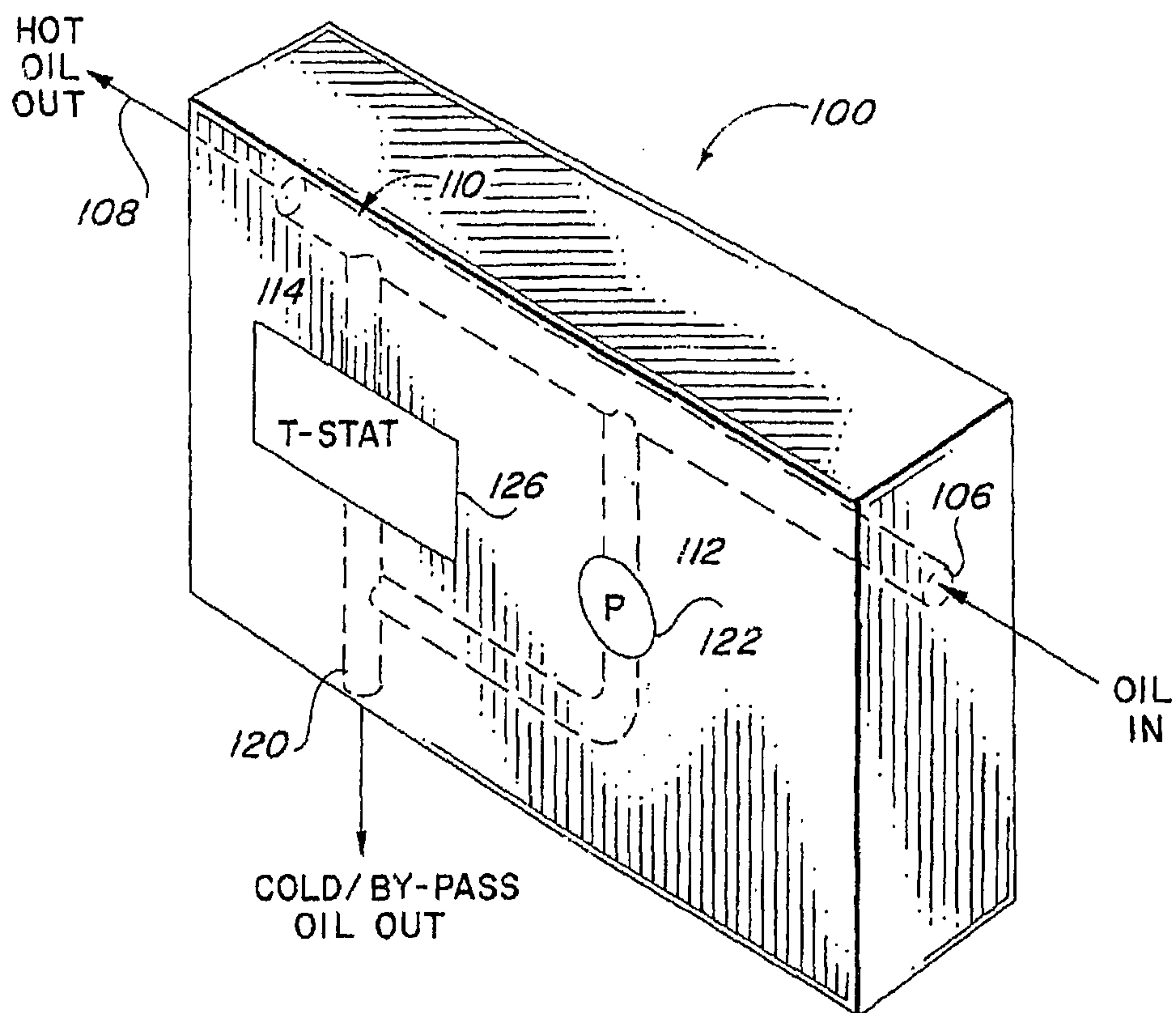

Fig. 5

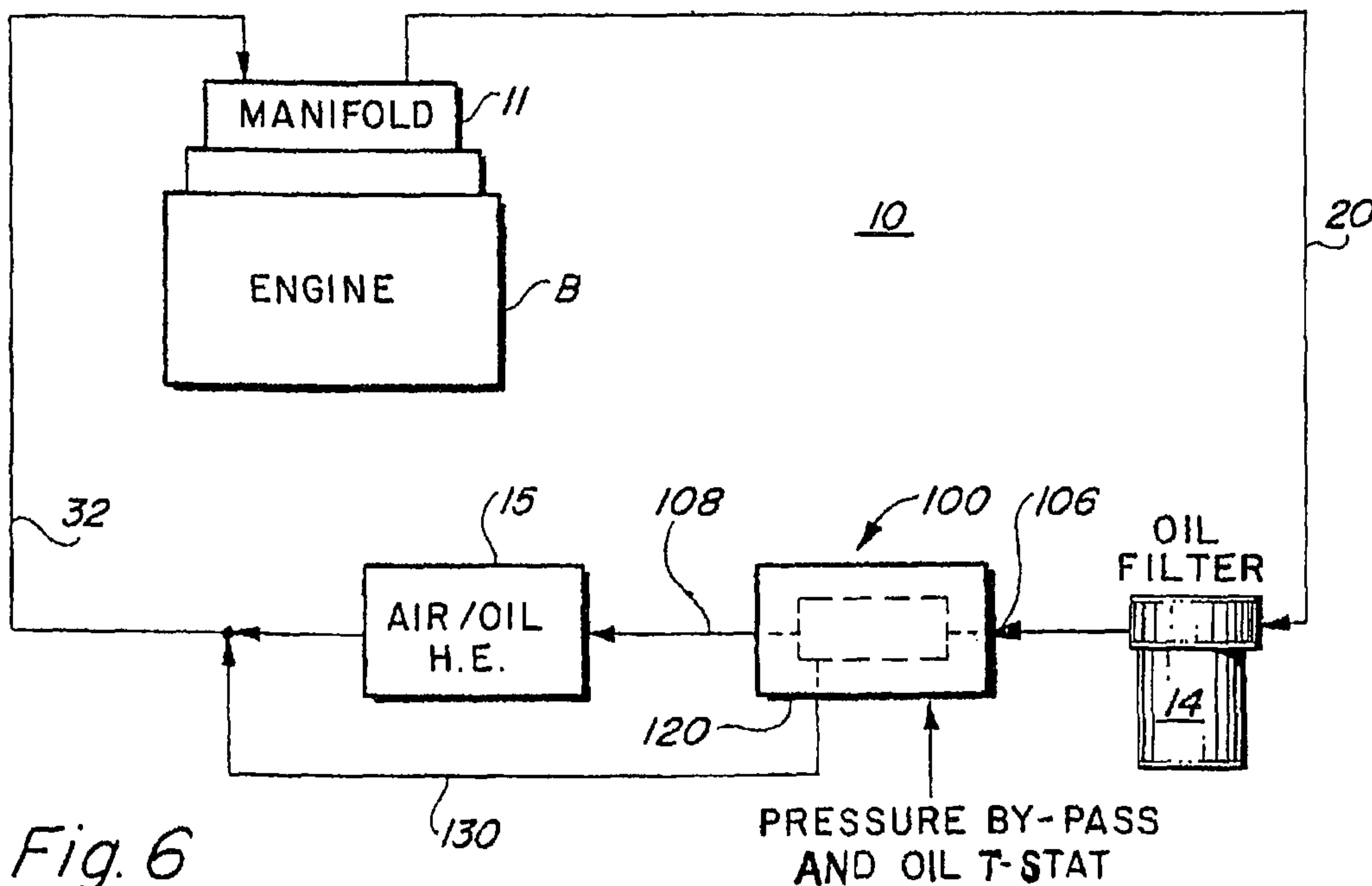

Fig. 6

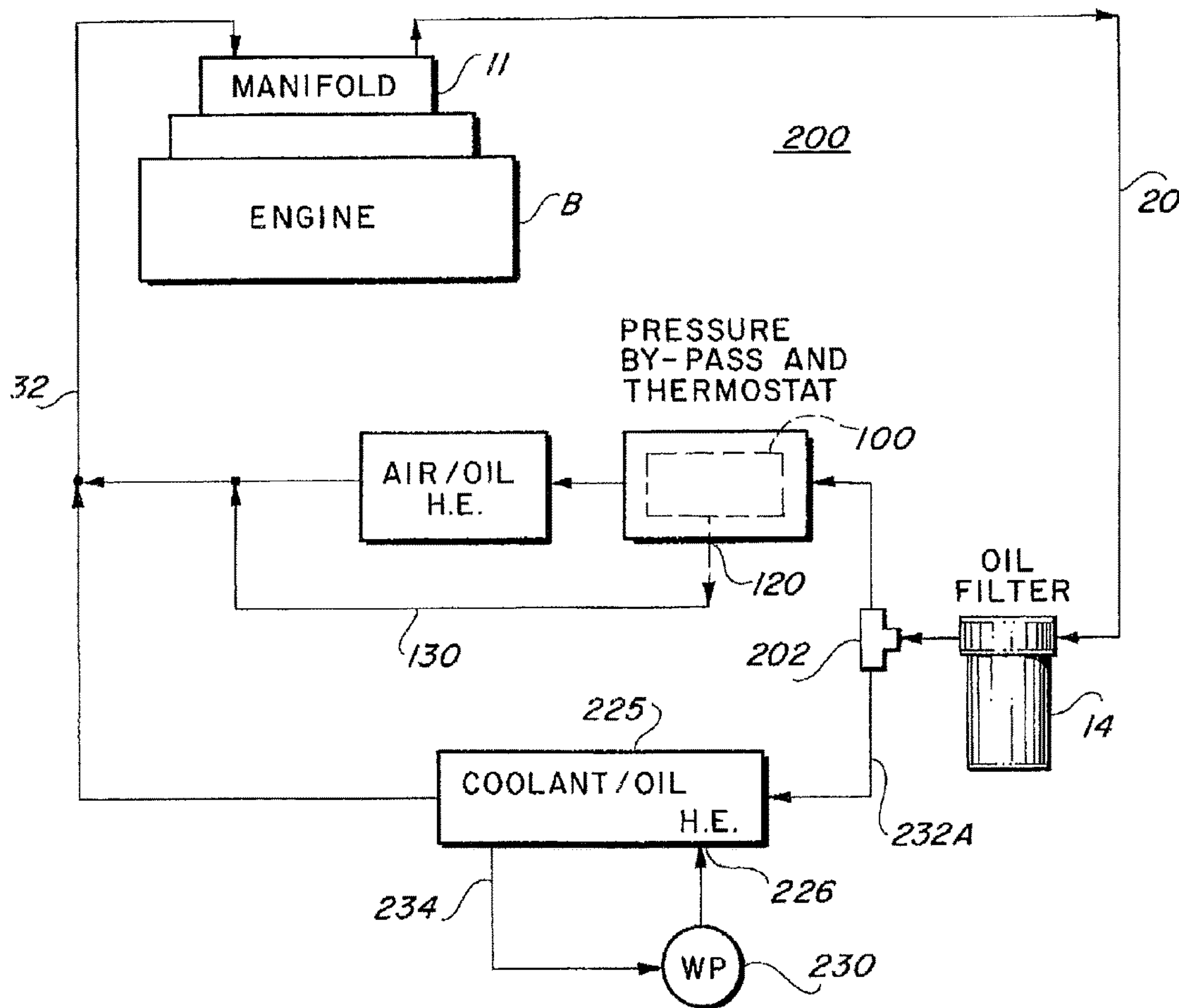

Fig. 7

APPARATUS FOR MODIFYING ENGINE OIL COOLING SYSTEM

Matter enclosed in heavy brackets [] appears in the original patent but forms no part of this reissue specification; matter printed in italics indicates the additions made by reissue; a claim printed with strikethrough indicates that the claim was canceled, disclaimed, or held invalid by a prior post-patent action or proceeding.

FIELD OF THE INVENTION

The present invention relates to a cooling system for an internal combustion engine and more particularly relates to an oil cooling system for both combustion ignition and diesel engines, collectively internal combustion (IC) engines.

BACKGROUND OF THE INVENTION

Most internal combustion engines require a cooling circuit having a coolant pump, radiator and passageways which circulate a coolant from the radiator through the engine block to cool the engine block and the moving components in the engine block. Lubricants, typically a synthetic or mineral-based oil, are utilized to lubricate the relatively moving surfaces in the engine to counteract friction, reduce wear and reduce operating temperatures.

However, excessive heat generated in the operation of the engine may cause the oil to degrade and break down losing its lubricating ability. When motor oils break down, they oxidize, thermally degrade and lose viscosity due to shear forces. As a result, many internal combustion engines, particularly high speed diesel engines and high performance combustion ignition engines, utilize engine block mounted oil coolers. Oil from the engine is passed through a cooler which operates as a heat exchanger with heat exchanger fluid, usually water and glycol, being provided from the engine cooling system from either the radiator or the engine block.

However, since the opening temperature of the thermostat in cooling systems of most internal combustion engines is approximately in the range of 180° to 200° Fahrenheit, an oil cooler utilizing engine coolant as the heat exchanger fluid is limited in its ability to cool the engine oil. By the operation of the cooling system thermostat in many engines, an oil temperature of approximately 200° to 220° F. is maintained so that the oil effectively lubricates and does not break down or degrade. Further, a low oil temperature is preferred because the oil, in addition to being a lubricant, also serves to cool the internal combustion engine components.

In a coolant to oil cooler system, the engine oil temperature is dependent upon the coolant supply. In the event of even a minor coolant loss, the engine may be damaged as the engine will incur the cooling loss provided both by the coolant and the engine oil.

Accordingly, there exists a need for an improved coolant to oil cooler system for IC engines which obviates the deficiencies set forth above.

BRIEF SUMMARY OF THE INVENTION

Briefly, the present invention provides a cooling system which replaces the conventional engine mounted coolant-to-oil heat exchanger with an external, high-capacity air-to-liquid heat exchanger. An adaptor block or manifold is

configured to replace an existing Original Equipment Manufacturer (OEM) engine oil cooler and is mounted in place on the engine block utilizing the existing mounting and similar hardware and gaskets that secure the conventional engine oil cooler in place.

The manifold is configured or ported with a passageway to receive the hot, unfiltered oil from the engine and directs the oil to a canister-style oil filter of the type having a replaceable cartridge. The filter may be located immediately adjacent to the manifold or may be at a remote location within the engine compartment. Filtered oil from the oil filter is directed to an external heat exchanger, preferably a high-capacity air to liquid heat exchanger, which returns the cooled and filtered oil to the manifold which, in turn, returns cooled and filtered oil to the engine. The system may also include separate bypass filtration and a particle filtration screen within the manifold, as well as an oil bleeder valve and an anti-siphon valve. Suitable provision is made in the manifold for installation of sensors to measure engine operating parameters such as oil pressure and temperature. Further provision can be made for oil supply to an accessory such as a turbo charger.

BRIEF DESCRIPTION OF THE DRAWINGS

The above and other advantages and objects of the present invention will become more apparent when taken in conjunction with the following description, claims and drawings in which:

FIG. 1 is a schematic representation of an embodiment of a cooling system according to the present invention;

FIG. 2 is a detailed perspective view of the adaptor or manifold section of the cooling system shown in FIG. 1;

FIG. 3 is a plan view of the bottom of the manifold showing a representative 5 mounting configuration which is adapted to replace the conventional OEM oil cooler;

FIG. 4 is a cross-sectional view of a section of the manifold illustrating the air bleed valve;

FIG. 5 is a schematic view of an engine oil by-pass that may be incorporated into the cooling system;

FIG. 6 is a schematic view showing the oil by-pass of FIG. 5 incorporated in the system of FIG. 1; and

FIG. 7 is a schematic showing a modified system as shown in FIG. 6 further including both coolant-to-oil and air-to-oil heat exchangers with by-pass features to provide warming of the engine oil upon start-up.

DETAILED DESCRIPTION

Turning now to the drawings, FIG. 1 shows the cooling system of the present invention mounted in place on the cylinder block B of an IC engine which is represented schematically by dotted lines. The mounting location may vary depending on the engine configuration. The IC engine may be a CI or diesel having an engine mounted cooler 8 which is removed and replaced with a manifold 11. The system indicated by the numeral 10 includes a housing or manifold 11 which may be cast and machined from a single block or billet of material such as steel or aluminum. Preferably the underside of the manifold, as best seen in FIG. 3, is machined to conform to the mounting configuration of the conventional coolant-to-oil cooler mounted on the engine block which cooler has been removed, having bolt holes 19 conforming to the existing bolt pattern. FIG. 3 shows a representative 5 mounting for a 6.0 L International® VT365 diesel engine also known as the 6.0 L Ford® Powerstroke diesel engine (hereinafter referred to as the "6.0

L VT365 diesel engine”) found in a 2004 Ford F350 truck. If the engine has not been originally equipped with an oil cooler, suitable mounting provision for the manifold must be made which may involve appropriate modifications such as tapping the engine block at suitable locations for mounting the manifold and installing suitable hydraulic lines.

However, in most cases, the cooling system of the present invention will be applicable and is adapted for replacement of a conventional engine mounted IC coolant-to-oil cooler and the following description proceeds on that basis. Once the existing oil cooler is removed, the manifold **11** is secured using suitable hardware and gaskets to position and mount the housing on the engine block B. Port or passageway **25** in the underside of the manifold aligns with a port P in the engine block B through which hot, unfiltered oil is directed to the manifold **11**. The oil enters the manifold at passageway **25** and flows through the manifold **11** exiting at port **13**. Port **13** is connected by a hydraulic line **20** to oil filter **14**. Line **20** has an anti-siphon check valve **21** to prevent reverse flow of oil through line **20**. The oil filter **14** may be located immediately adjacent the manifold **11** or may be at a convenient location in the engine compartment considering engine size, available space and other installation restrictions.

The oil filter **14** is a canister-type and has an inlet **22** which communicates with and receives oil from the manifold. The housing has a lower screw or spin-on body **24** which is removable. The body **24** contains a suitable element **26** of a filtering material such as paper or fiber which is periodically replaceable. Preferably the filter is a conventional filter available from manufacturers such as FRAM, WIX and others. Particulates and contaminants are substantially removed as the oil passes through the filter element **26**.

The oil exiting oil filter **14** is then directed to an external heat exchanger, preferably an air-to-liquid heat exchanger **15**. The external heat exchanger may be a tube or plate design and is preferably of the tube type having a tube **28** carrying the oil to be cooled which extends in serpentine fashion within the heat exchanger housing. Because air is a relatively poor conductor of heat, the heat transfer area between the air passing over the tubes is increased by adding fins **30** to the tubes. The heat exchanger **15** is mounted in a location remote from the location of the OEM heat exchanger, preferably located in the vehicle to receive substantial airflow, for example at the front of the vehicle immediately adjacent and in front of the radiator for the engine cooling system. Ducting may be provided to increase airflow to the heat exchanger **15**.

The oil which has been cooled and filtered is returned to an inlet port **17** on the manifold **11** via line **32**. The inlet port **17** connects with internal passageway **34** communicating with outlet port **12**. The outlet port **12** on the bottom of the manifold is aligned and communicates with the engine block port P so the cooled and filtered oil returns to the engine to provide lubrication. An additional outlet port **12A**, as seen in FIG. 3, is provided to supply cooled and filtered oil to the high pressure oil pump.

Additional filtering may be provided by a bypass filter **18**. The bypass filter **18** is a separate filter and may be of the canister type as described with reference to filter **14**. A bypass line **36** removes a portion of the cooled and filtered oil prior to the oil entering into port **17** and directs the oil to the inlet of the bypass filter **18**. The bypass filter **18** has an outlet which directs the flow via line **38** to port **12** to be returned to the engine **5**.

Passageway **34** connected to port **17** may also be intercepted by passageways **40**, **42** and **44** which are suitably

threaded for connection to gauges such as the pressure gauge at **40**, temperature gauge **42** and oil feed for the turbo at **44**. Other sensing locations can also be provided to measure other operating parameters. Provision is made in the manifold to circulate coolant through the engine cooling system. Coolant enters the manifold at port **55** and exits at port **56** where it is returned to the engine cooling system without passing through the external heat exchanger **15**. The coolant thus returned to the engine cooling system is circulated by a water pump through the existing passages in the engine block and radiator.

In many engines, metal particles will be released during operation. In addition to metal particles, sand used in the engine block casting process and retained in the engine may also be released. These larger, particulate materials can be harmful to the engine and may also quickly clog or reduce the effectiveness of the filters, such as the F1A filter, which are primarily intended to remove finer particulate materials.

The oil cooling system of the present invention may be provided with a particulate filter internal within the manifold **11** to trap and remove larger particulates which may otherwise quickly impair the effectiveness of element type filters. A cavity **50** is provided within the housing and removably receives a screen **52** having a mesh in the 0.003 to 0.005 inch range. The screen is accessible and removable by detaching the manifold from the engine block or access may be provided through a suitable access panel **54** on the manifold. A portion of the cooled and filtered oil entering the manifold at port **17** may be internally diverted to the cavity **50** and onto a surface of the particulate screen **52**. The oil will, due to pressure existing in the system and gravity, flow downwardly through the screen to ports **12** and **12A** returning to the engine. Particulate material will collect on the screen **52** and may be periodically removed by accessing the screen by removal of the manifold or through an access panel as described above.

An oil bleed valve **16** may be provided as seen in FIG. 4. The oil bleed valve **16** is in a passageway **60** communicating with passageway **34**. A ball **65** is held in place by a spring **66**. The spring **66** is retained by a plug **68** with a small orifice **70**. Passageway **60** is closed by a plug **72**. When the pressure in passageway **34** exceeds a predetermined level, the ball **65** will open returning oil to the engine crank case via line **62**, allowing air within the engine’s oil system to be removed.

FIGS. 2 and 3 illustrate a representative configuration for the manifold and for the configuration of the passageways within the manifold which may be utilized in connection with the cooling system of the present invention. However, it will be appreciated that the particular configuration shape of the manifold may vary with the intended installation. It will also be appreciated that the present system has broad utility and application to various internal combustion engines of different types and displacement. Accordingly, while the present invention has been described in detail with reference to a preferred embodiment it is to be understood that the disclosure has only illustrated an exemplary embodiment.

FIGS. 5 and 6 are schematics which show a by-pass **100** that may be incorporated into the system **10** shown in FIG. 1. Referring to FIG. 5, which **5** shows the by-pass **100** which has a housing **102** having an inlet **106** and outlet **108** connected by a passageway **110** is intercepted by a pressure by-pass line **112** and a temperature by-pass line **114** both of which communicate with by-pass outlet **120**. A pressure control valve **122** such as a spring-biased valve is located in line **112**. The valve **122** may be a direct acting relief valve which opens at a fixed pre-set pressure established by a

5

spring which may be adjusted by a spring adjustment screw. The valve is set to by-pass fluid to the outlet when the differential pressure between the inlet and outlet of the oil cooler is above the setting, typically about 40-50 psi, which differential may initially occur during start-up before the pressure in the system generated by the engine oil pump has fully pressurized the engine oil system.

Similarly, the temperature by-pass line includes a thermostatic control **126** which has a selected opening temperature generally between 170-200° F. The thermostat control will block flow through the by-pass **100** and direct the oil flow to outlet **120** until such time as the temperature of the oil reaches a temperature at which the thermostat is set to open. Thus, the oil entering the by-pass **100** will be directed to the cold by-pass outlet **120** if either: (1) the engine oil is below a predetermined temperature by the closed thermostat **126** or (2) the oil pressure differential between the inlet and outlet of the oil cooling heat exchanger **15** is greater than the differential setting of the control valve **122**.

In FIG. 6, the by-pass **100** is shown in the system **10** of FIG. 1. The system **10** has been simplified in FIG. 6 but is as described in greater detail with reference to FIG. 1 which description is incorporated here by reference. The by-pass **100** is located adjacent the air-to-liquid heat exchanger **15**, either ahead of the heat exchanger **15** or downstream of the discharge. In FIG. 6, the by-pass **100** is shown ahead of the heat exchanger **15**. The outlet **108** of the by-pass **100** is in communication with the heat exchanger **15**. The by-pass outlet **120** is connected via by-pass line **130** to line **32** leading to the manifold **11**. Accordingly, if engine oil is below a predetermined temperature or if a predetermined pressure differential exists between the inlet and outlet of oil exceeding the setting of control valve **122**, oil will be by-passed through by-pass **100** allowing the system oil temperature and pressure to build to acceptable levels due to engine operation. This typically may take 4 or 5 seconds after start up. The by-pass **100** lessens stress and wear on engine components due to oil conditions which reduce the effectiveness of the lubrication.

In FIG. 7, a modification of the system **10** of claim **1** is shown which is adopted for engines which operate in colder climates. The system of FIG. 7 is indicated by the numeral **200** and includes a manifold **11** secured to the engine block B as described with reference to FIG. 1. The hot, unfiltered oil from the engine is directed to a filter **14** by line **20** and exits the filter **14** to tee **202** having outlet lines **232**, **232A**. Line **232** is directed to by-pass **100** located adjacent an air-to-liquid heat exchanger **15**. The by-pass **100** is as described with reference to FIGS. 5 and 6. The heat exchanger **15** is as has been previously described with reference to FIG. 1. The by-pass **100** will direct engine oil either to the heat exchanger **15** or, if the temperature or pressure conditions of the oil are within predetermined by-pass parameters, the oil will be by-passed around the heat exchanger **15** via line **130** to line **32**.

The engine oil discharged through line **232A** is directed to a coolant-to-oil heat exchanger **225** which receives liquid coolant at inlet port **226** from the engine cooling system under pressure from the engine water pump **230** which is recirculated from the heat exchanger via line **234**. The thermostat in the engine cooling system will operate at a preset opening temperature of typically around 190°-200° F. and be circulated by the water pump **230** through the heat exchanger **225** to warm the oil initially flowing through the heat exchanger from the filter. As the engine warms and the engine oil is heated, the heat exchanger **225** will operate to maintain the oil temperature at about the temperature of the

6

engine coolant fluid from the water pump. Thus, the heat exchanger initially assists in heating the engine oil during the initial engine start-up and thereafter will operate to maintain the oil at an acceptable temperature.

The dual system of FIG. 7 having both an air heat exchanger and a liquid heat exchanger in parallel enhances or increases the effective heat exchange area and operates to cool engine oil during operation and will heat or warm the engine oil during initial start-up and has particular application to engines operating in colder climates or conditions.

It will be obvious to those skilled in the art to make various changes, alterations and modifications to the invention described herein. To the extent such changes, alterations and modifications do not depart from the spirit and scope of the appended claims, they are intended to be encompassed therein.

What is claimed is:

1. A kit of parts for modifying an original equipment oil cooling system for a vehicle having a diesel engine, the diesel engine having an engine block with oil passages, an oil pump for circulating oil, and a water cooling system with a water pump and water cooling passages disposed in the engine block, the engine having an original equipment liquid-to-liquid heat exchanger in which heat from the oil is transferred to the water cooling system of the engine, the original equipment liquid-to-liquid heat exchanger being imbedded within the engine and having a predetermined mounting configuration, the original equipment liquid-to-liquid heat exchanger further comprising an oil inlet, an oil outlet, a water inlet, and a water outlet each in a predetermined location, the kit comprising:

(a) a manifold adapted to be installed in the engine in place of the original equipment liquid-to-liquid heat exchanger, the manifold having an oil inlet port and an oil outlet port, the manifold being sized and shaped to match the mounting configuration of the original equipment liquid-to-liquid heat exchanger such that when the manifold is mounted to the engine, the oil inlet port of the manifold is positioned at the former location of the oil inlet of the original equipment liquid-to-liquid heat exchanger and the oil outlet port of the manifold is positioned at the former location of the oil outlet of the original equipment liquid-to-liquid heat exchanger, the manifold oil outlet port, in an installed position, providing a flow of oil to an external oil cooling heat exchanger mounted in a location different from the location of the original equipment liquid-to-liquid heat exchanger, the manifold further comprising a bypass water passage having a single water inlet port and a single water outlet port, the manifold being configured such that when the manifold is in the installed position the water inlet port of the manifold is positioned at the former location of the water inlet of the original equipment liquid-to-liquid heat exchanger and the manifold water outlet port is operatively attached to the water cooling system of the engine so that the entirety of the flow of water in the bypass water passage is discharged back to the water cooling system of the engine; and

(b) an external oil cooling heat exchanger having an external mount configured to mount the external oil cooling heat exchanger in a location different from the location of the original equipment liquid-to-liquid heat exchanger, the external oil cooling heat exchanger having an inlet fitting and an outlet fitting sized to receive the flow of oil from the oil outlet port of the manifold and return the flow of oil to the engine.

7

2. The kit of claim 1, wherein the vehicle comprises a front end and a back end, the kit further comprising: brackets for mounting the external oil cooling heat exchanger proximal the front end of the vehicle.
3. The kit of claim 1, further comprising: oil cooler hoses for operatively connecting the external oil cooling heat exchanger with the manifold.
4. The kit of claim 1, wherein: the external oil cooling heat exchanger is an air-to-liquid heat exchanger.
5. The kit of claim 4, wherein: the air-to-liquid heat exchanger is a tube-and-fin heat exchanger.
6. The kit of claim 1, wherein: the manifold includes at least one sensor port.
7. The kit of claim 1, wherein: the manifold includes a lower surface that retains a substantially flat particulate filter screen which receives a portion of the flow of oil from said manifold.
8. The kit of claim 1, further comprising: a housing containing an oil filter operatively connected between the manifold and the external oil cooling heat exchanger.
9. The kit of claim 1, wherein: the external oil cooling heat exchanger is a plate-type heat exchanger.
10. A kit of parts for modifying an original equipment oil cooling system for a vehicle having a diesel engine, the diesel engine having an engine block with oil passages, an oil pump for circulating oil, and a water cooling system with a water pump and water cooling passages disposed in the engine block, the engine having an original equipment liquid-to-liquid heat exchanger in which heat from the oil is transferred to the water cooling system of the engine, the original equipment liquid-to-liquid heat exchanger being imbedded within the engine and having a predetermined mounting configuration, the original equipment liquid-to-liquid heat exchanger further comprising an oil inlet, an oil outlet, a water inlet, and a water outlet each in a predetermined location, the kit comprising:

8

- (a) a manifold adapted to be installed in place of the original equipment liquid-to-liquid heat exchanger, the manifold having an oil inlet port and an oil outlet port, the manifold being sized and shaped to match the mounting configuration of the original equipment liquid-to-liquid heat exchanger such that when the manifold is mounted to the engine, the oil inlet port of the manifold is positioned at the former location of the oil inlet of the original equipment liquid-to-liquid heat exchanger and the oil outlet port of the manifold is positioned at the former location of the oil outlet of the original equipment liquid-to-liquid heat exchanger, the manifold further comprising a bypass water passage having a single water inlet port and a single water outlet port, the manifold being configured such that when the manifold is in the installed position the water inlet port of the manifold is positioned at the former location of the water inlet of the original equipment liquid-to-liquid heat exchanger and the manifold water outlet port is operatively attached to the water cooling system of the engine so that the entirety of the flow of water in the bypass water passage is discharged back to the water cooling system of the engine, the manifold further including a lower surface that retains a substantially flat particulate filter screen which receives a portion of the flow of oil from said manifold; and
- (b) an external oil cooling heat exchanger having an external mount configured to mount the external oil cooling heat exchanger in a location different from the location of the original equipment liquid-to-liquid heat exchanger, the external oil cooling heat exchanger having an inlet fitting and an outlet fitting sized to receive a flow of oil from the oil outlet port of the manifold and return the flow of oil to the engine.

* * * * *