



US00RE46954E

(19) **United States**
(12) **Reissued Patent**
Pedicini

(10) **Patent Number: US RE46,954 E**
(45) **Date of Reissued Patent: *Jul. 17, 2018**

(54) **ELECTRIC MOTOR DRIVEN TOOL FOR ORTHOPEDIC IMPACTING**

(58) **Field of Classification Search**
CPC . A61B 17/92; A61B 17/1659; A61B 17/1622;
A61B 17/1624; A61B 17/1668;

(71) Applicant: **Medical Enterprises, LLC**, Nashville, TN (US)

(Continued)

(72) Inventor: **Christopher Pedicini**, Franklin, TN (US)

(56) **References Cited**

U.S. PATENT DOCUMENTS

(73) Assignee: **Medical Enterprises, LLC**, Nashville, TN (US)

974,267 A 11/1910 Hennessy B25D 11/125
173/201
3,712,390 A * 1/1973 Berg 173/132

(Continued)

(*) Notice: This patent is subject to a terminal disclaimer.

FOREIGN PATENT DOCUMENTS

(21) Appl. No.: **14/850,639**

DE 103 19 350 11/2004
EP 0 617 926 B1 8/1998

(Continued)

(22) Filed: **Sep. 10, 2015**

OTHER PUBLICATIONS

Related U.S. Patent Documents

International Search Report and Written Opinion dated Nov. 2, 2016 in International Application No. PCT/US2016/015380.

Reissue of:

(64) Patent No.: **8,602,124**
Issued: **Dec. 10, 2013**
Appl. No.: **13/790,870**
Filed: **Mar. 8, 2013**

Primary Examiner — Catherine S Williams
(74) *Attorney, Agent, or Firm* — Gardella Grace P.A.

U.S. Applications:

(63) Continuation of application No. 13/759,813, filed on Feb. 5, 2013, now abandoned, which is a (Continued)

(57) **ABSTRACT**

An orthopedic impacting tool comprises a motor, an energy storage chamber, a striker, and an anvil. The motor stores energy in the energy storage chamber and then releases it, causing the striker to apply a controlled force on an adapter to create a precise impact for use in a surgical setting. The tool may further comprise a combination anvil and adapter. The tool further allows forward or backward impacting for expanding the size or volume of the opening or for facilitating removal of a broach, implant, or other surgical implement from the opening. An energy adjustment control of the tool allows a surgeon to increase or decrease the impact energy. A light source and hand grips improve ease of operation of the tool.

(51) **Int. Cl.**
B25D 17/00 (2006.01)
A61B 17/92 (2006.01)
(Continued)

(52) **U.S. Cl.**
CPC **B25D 17/00** (2013.01); **A61B 17/1659** (2013.01); **A61B 17/92** (2013.01);
(Continued)

17 Claims, 10 Drawing Sheets

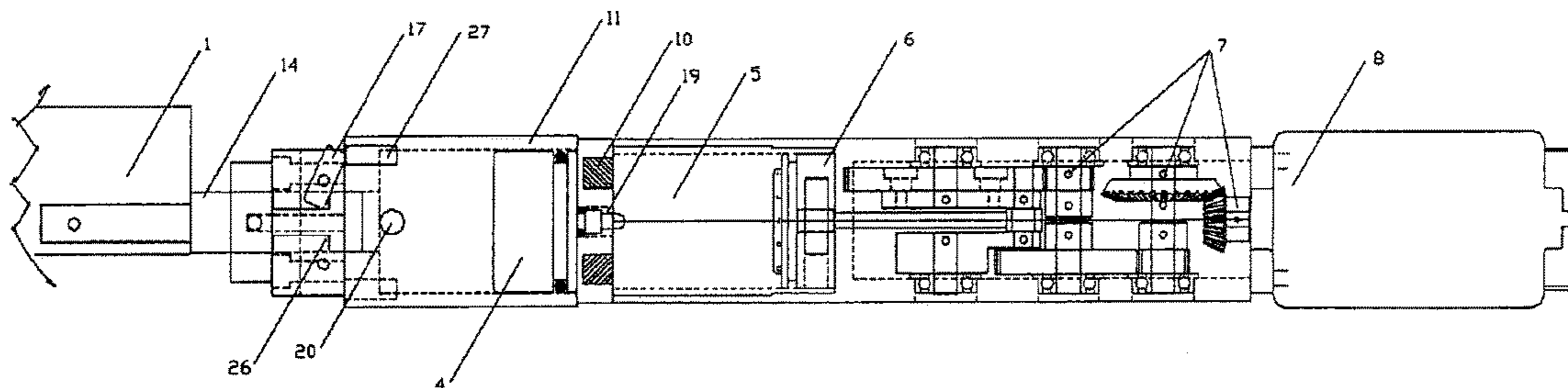

Related U.S. Application Data

continuation-in-part of application No. 12/980,329, filed on Dec. 29, 2010, now Pat. No. 8,695,726, and a continuation of application No. 13/466,870, filed on May 8, 2012, now Pat. No. 8,393,409, said application No. 13/790,870 is a continuation-in-part of application No. 12/980,329, and a continuation-in-part of application No. 13/466,870, which is a continuation of application No. 13/337,075, filed on Dec. 24, 2011, now abandoned, and a continuation-in-part of application No. 12/980,329.

(60) Provisional application No. 61/603,320, filed on Feb. 26, 2012, provisional application No. 61/682,915, filed on Aug. 14, 2012, provisional application No. 61/734,539, filed on Dec. 7, 2012.

(51) **Int. Cl.**

A61B 17/16 (2006.01)
A61B 90/30 (2016.01)

(52) **U.S. Cl.**

CPC *A61B 17/1626* (2013.01); *A61B 17/1628* (2013.01); *A61B 17/1668* (2013.01); *A61B 2017/922* (2013.01); *A61B 2090/309* (2016.02)

(58) **Field of Classification Search**

CPC A61B 17/1626; A61B 17/1628; A61B 17/1604; A61B 2017/922; A61B 2017/924; A61B 2017/927; A61F 2/4603; A61F 2/46; A61F 2002/4602
USPC 173/2, 48, 104, 109, 114, 132, 176, 201, 173/217

See application file for complete search history.

(56)

References Cited

U.S. PATENT DOCUMENTS

4,143,585 A 3/1979 Selsam
4,442,906 A * 4/1984 Simpson 173/48
5,057,112 A * 10/1991 Sherman et al. .. A61B 17/1604
606/100

5,108,400 A 4/1992 Appel et al. A61B 17/1659
173/91
5,485,887 A * 1/1996 Mandanis A61B 17/92
173/135
5,553,675 A * 9/1996 Pitzen A61B 17/1628
173/217
6,112,830 A * 9/2000 Ziegler et al. 173/109
6,264,660 B1 7/2001 Schmidt et al.
6,413,230 B1 7/2002 Haupt et al.
6,520,266 B2 * 2/2003 Bongers-
Ambrosius B25D 11/12
173/115
6,644,418 B2 * 11/2003 Haga 173/48
6,938,705 B2 9/2005 Kikuchi
7,001,393 B2 2/2006 Schwenke et al.
7,189,241 B2 3/2007 Yoon et al.
7,383,895 B2 * 6/2008 Aoki 173/201
7,784,562 B2 * 8/2010 Ikuta 173/201
7,861,799 B2 * 1/2011 Iwakami et al. 173/201
7,926,584 B2 * 4/2011 John et al. 173/1
8,292,909 B1 10/2012 Dubois et al.
8,393,409 B2 * 3/2013 Pedicini 173/201
8,465,491 B2 6/2013 Yedlicka et al.
8,926,625 B2 1/2015 Lebet
8,936,105 B2 1/2015 Pedicini
8,936,106 B2 1/2015 Pedicini
8,936,603 B2 1/2015 Mani et al.
8,936,604 B2 1/2015 Mani et al.
8,968,326 B2 3/2015 Mani et al.
2005/0096661 A1 5/2005 Farrow et al.
2007/0264485 A1 11/2007 Stepanian et al.
2008/0215056 A1 9/2008 Miller et al.
2013/0261681 A1 10/2013 Bittenson
2015/0127013 A1 5/2015 Mani et al.
2015/0182233 A1 7/2015 Van Wyk et al.
2015/0289886 A1 10/2015 Kfir

FOREIGN PATENT DOCUMENTS

EP 2 455 006 5/2012
FR 2 455 006 5/2012
JP 6-283217 10/1994
JP 7-226230 8/1995
JP 2006-218228 8/2006

* cited by examiner

FIGURE 1

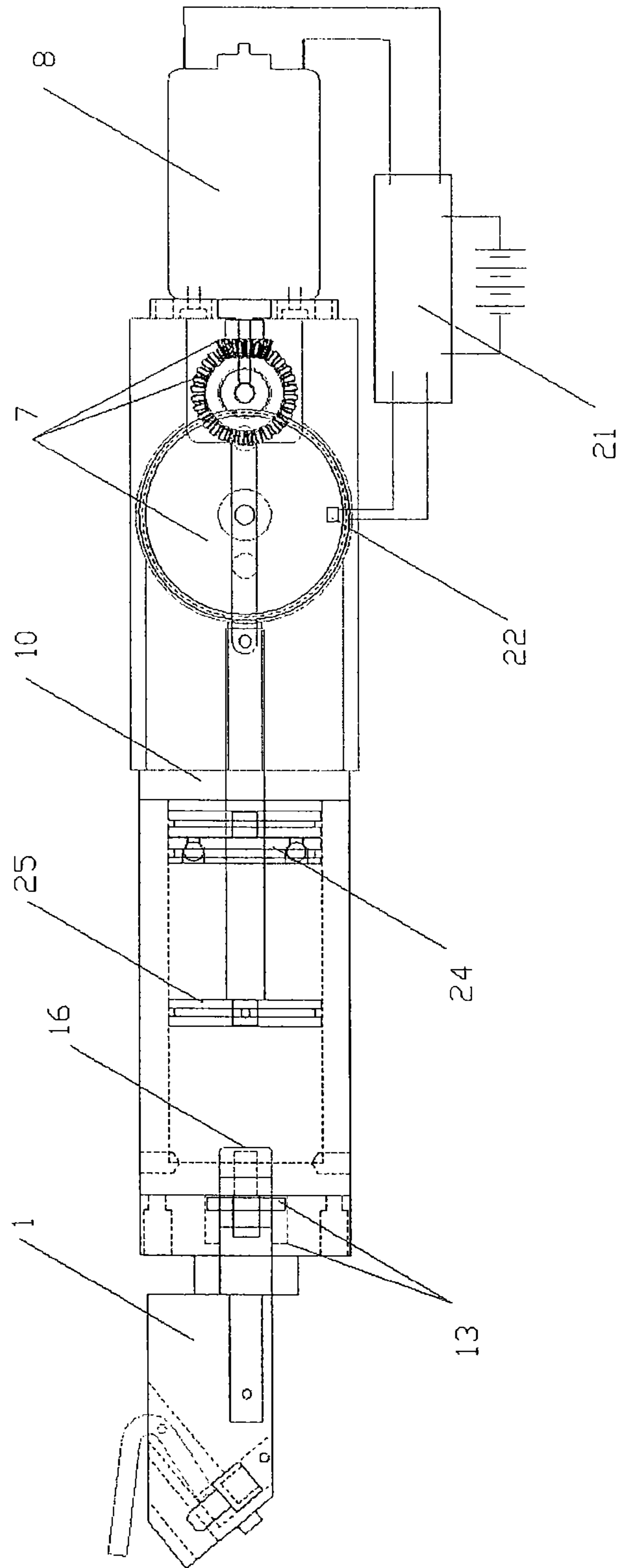

FIGURE 2

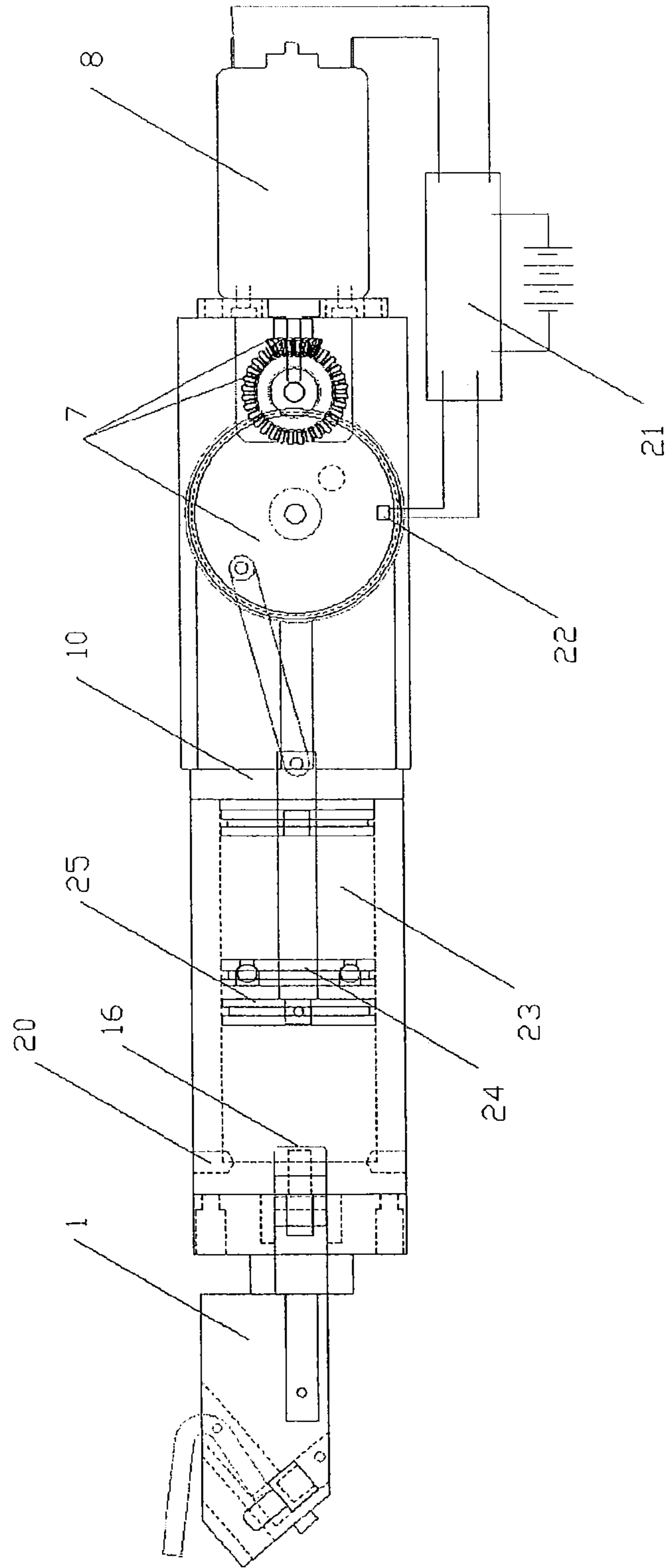

FIGURE 3

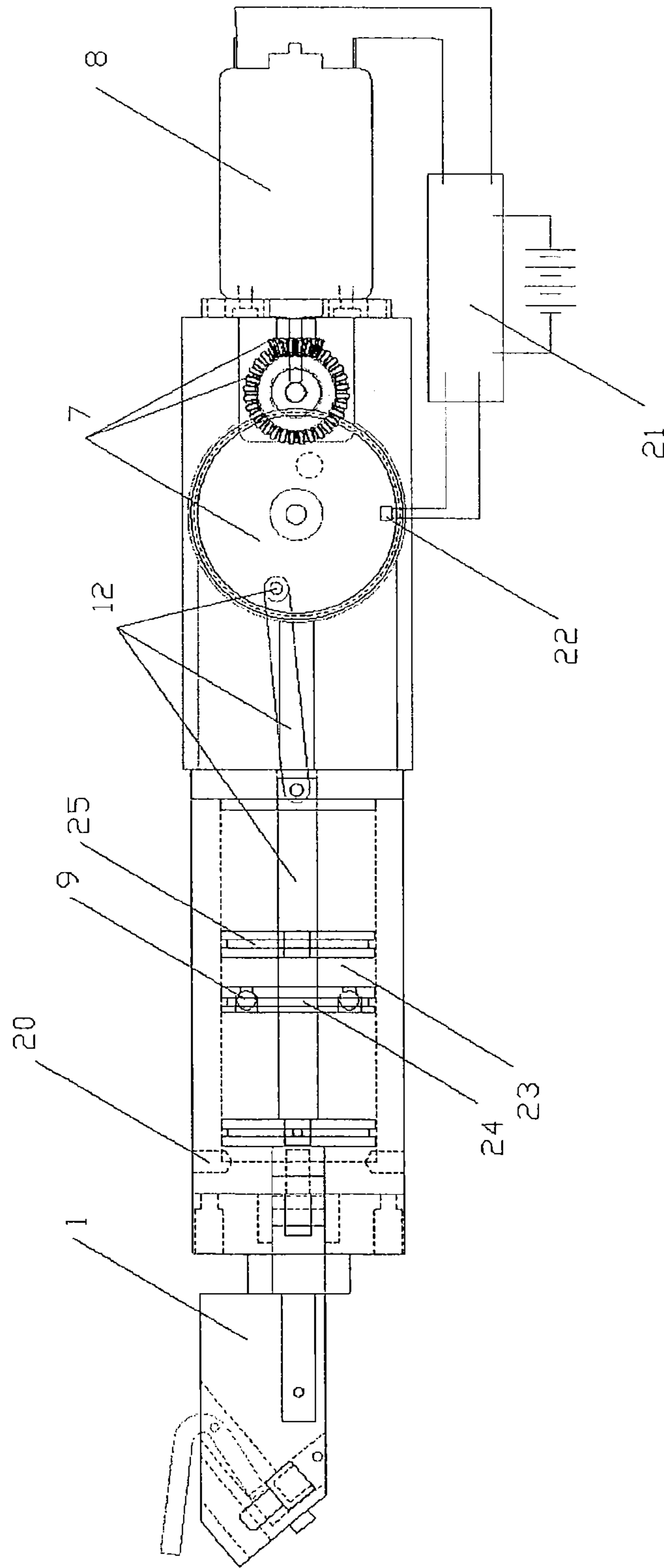

FIGURE 4

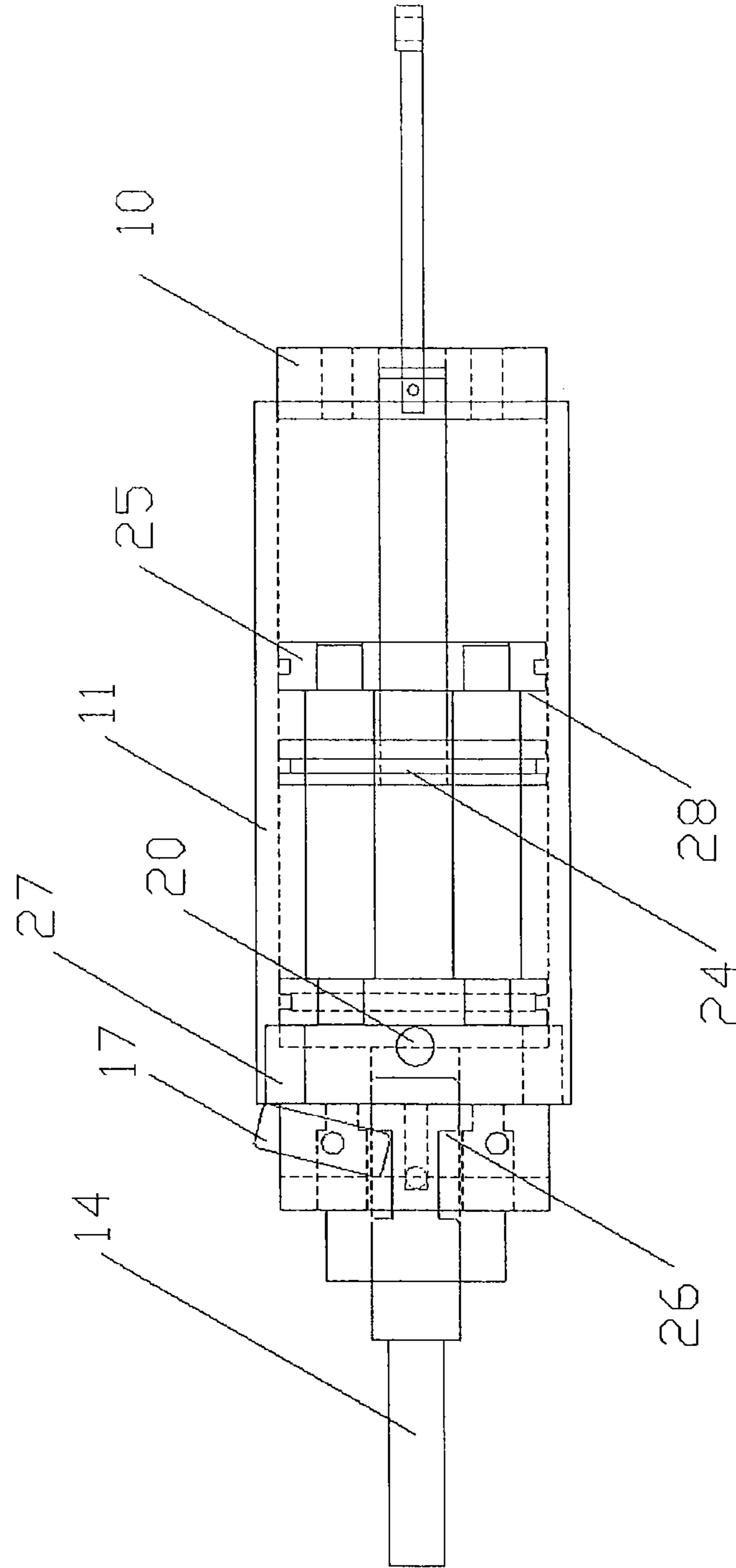

FIGURE 5

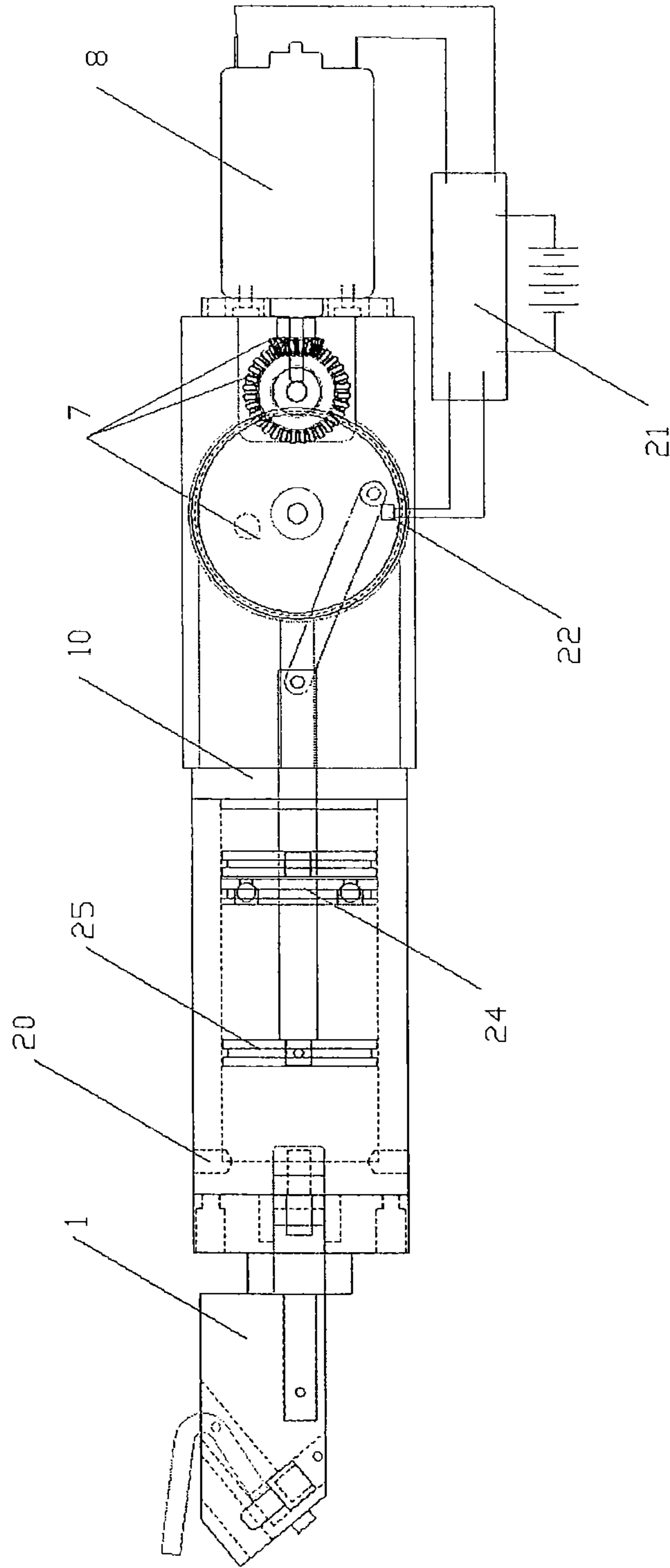

FIGURE 6

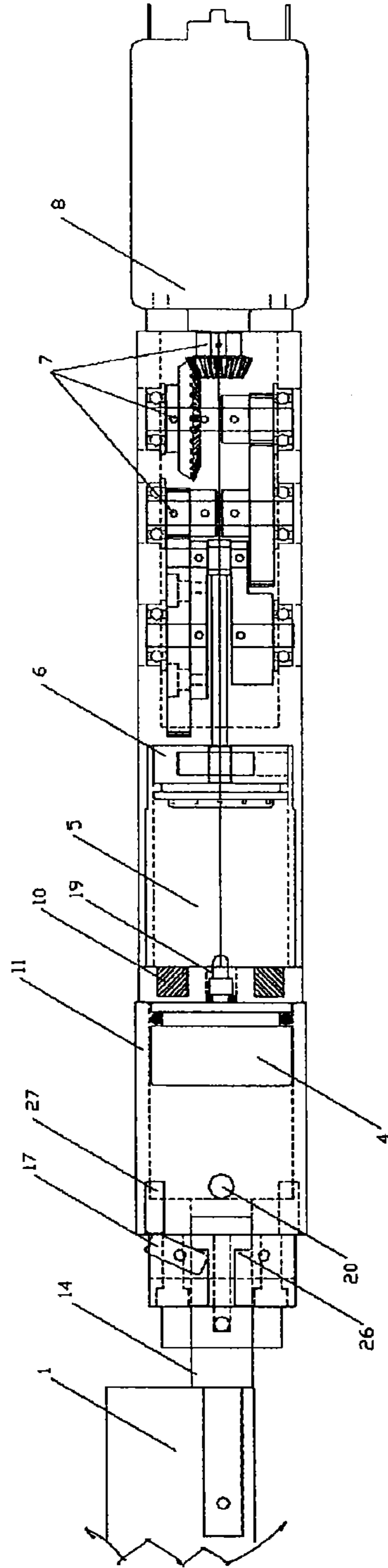

FIGURE 7

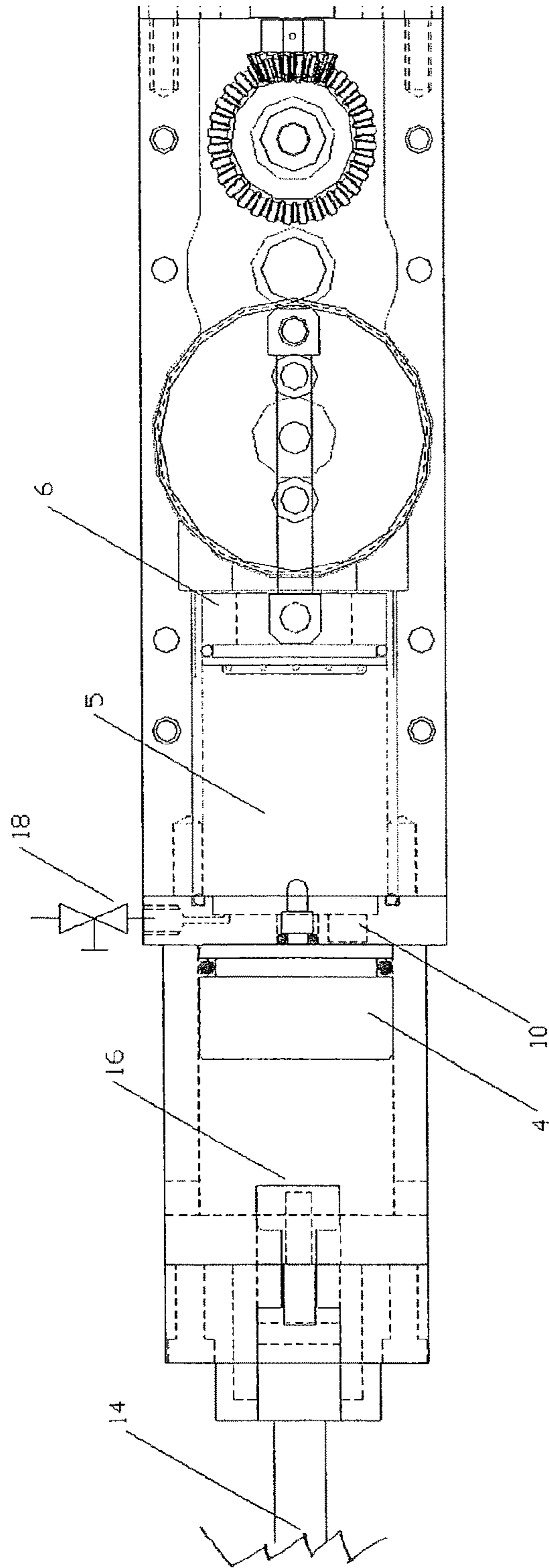

FIGURE 8

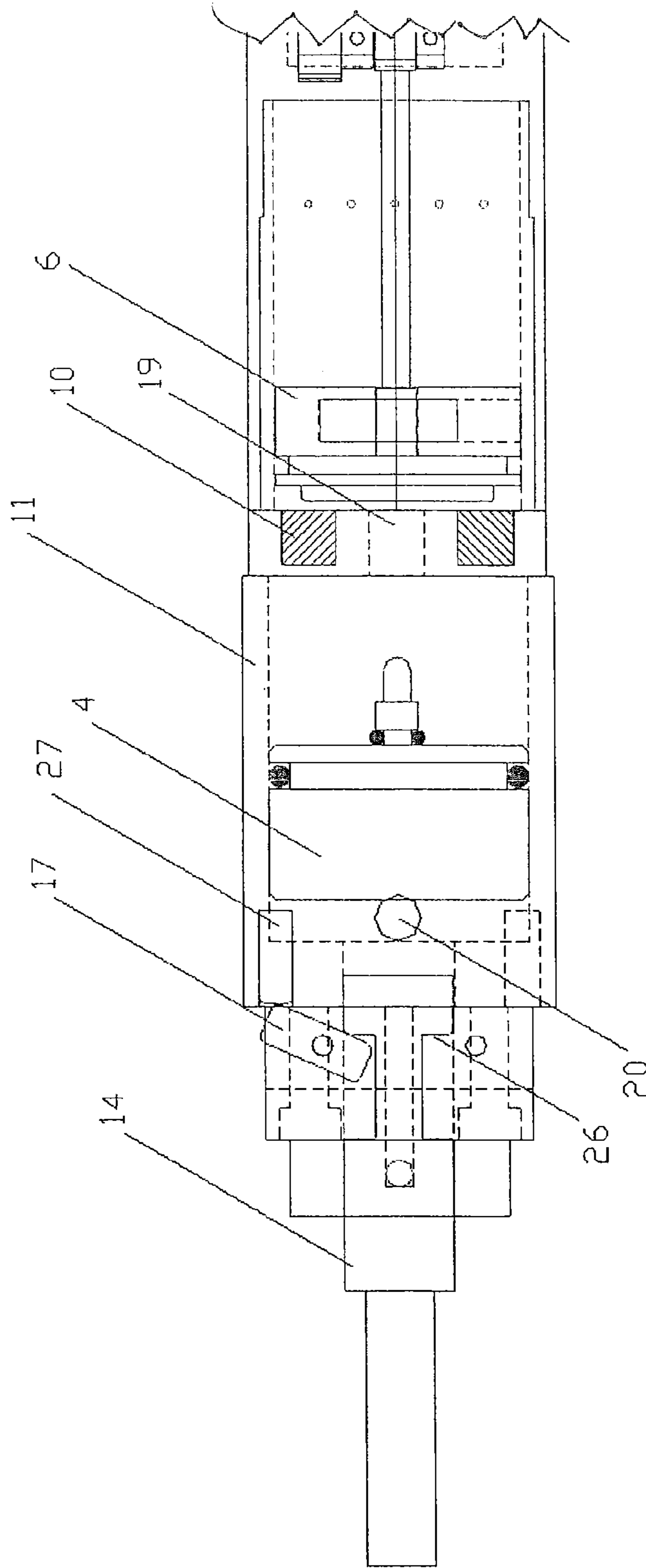
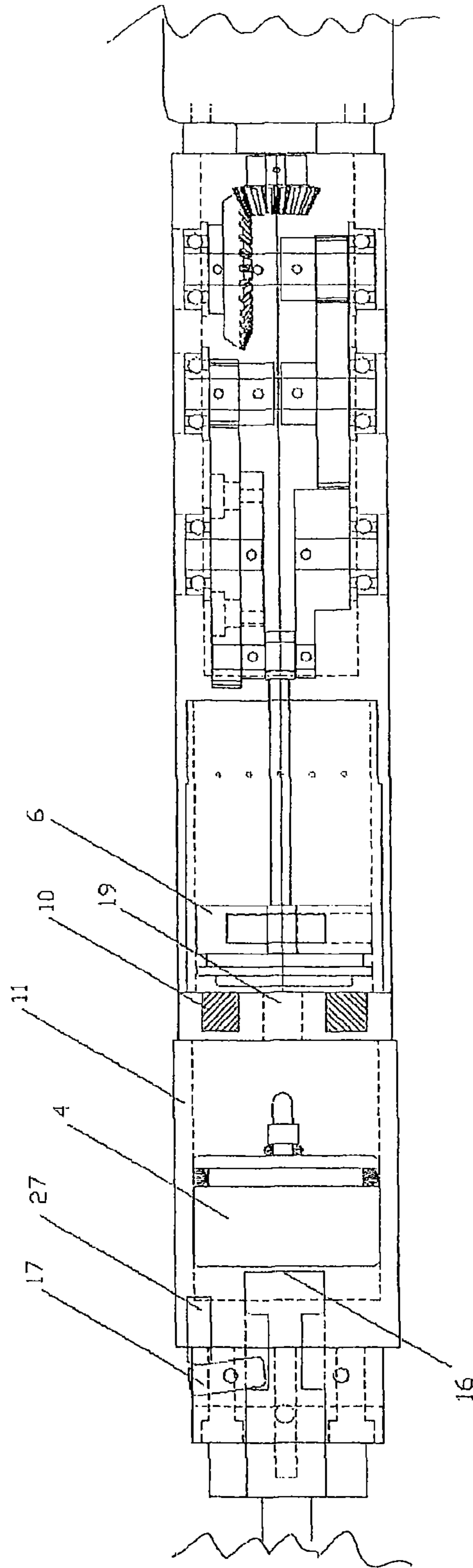

FIGURE 9



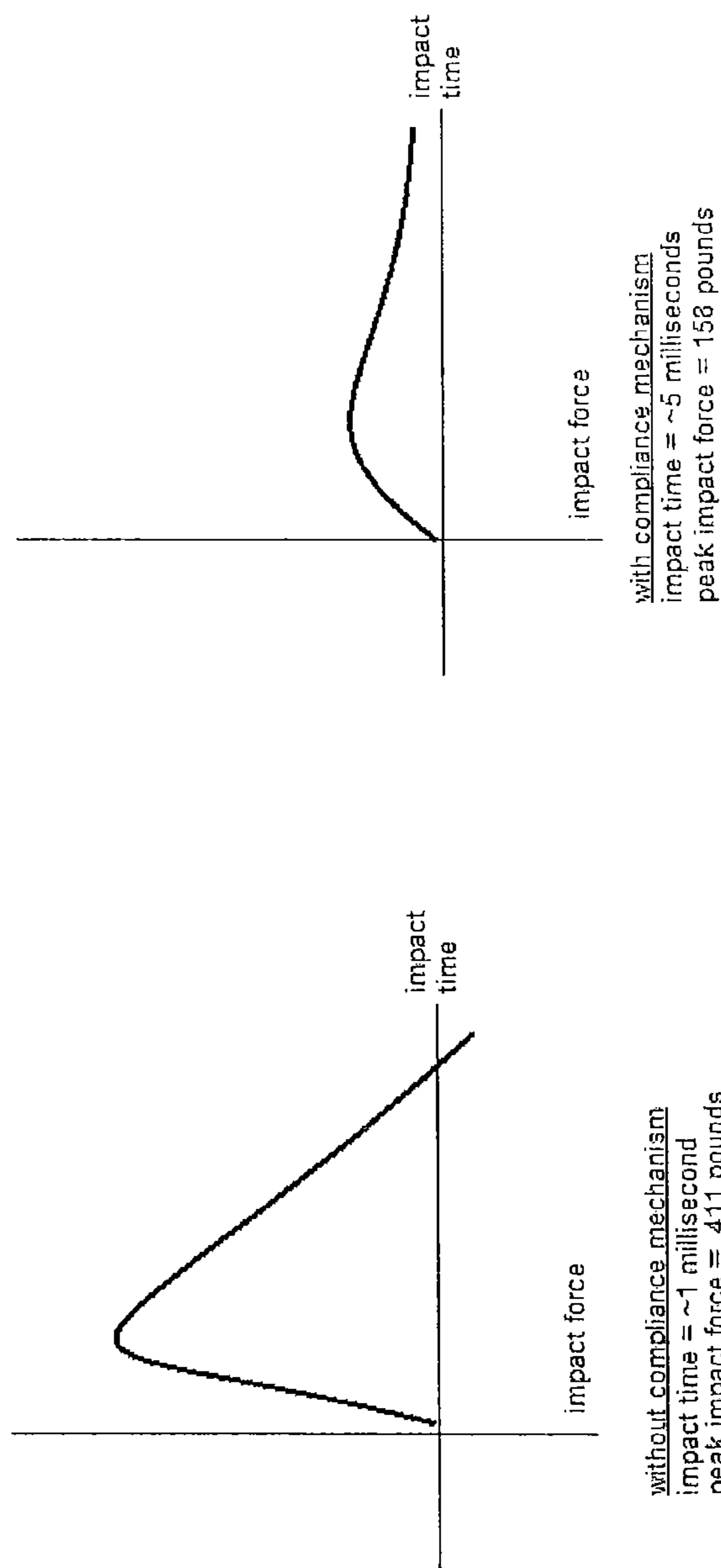

FIGURE 10

**ELECTRIC MOTOR DRIVEN TOOL FOR
ORTHOPEDIC IMPACTING**

Matter enclosed in heavy brackets [] appears in the original patent but forms no part of this reissue specification; matter printed in italics indicates the additions made by reissue; a claim printed with strikethrough indicates that the claim was canceled, disclaimed, or held invalid by a prior post-patent action or proceeding.

CROSS-REFERENCE TO RELATED
APPLICATIONS

It is noted that more than one application for reissue of U.S. Pat. No. 8,602,124 has been filed. Each of U.S. patent application Ser. Nos. 14/850,588, 14/850,620, 14/850,639, 14/850,660, 14/850,674, and 14/850,695 were filed on Sep. 10, 2015 for reissue of U.S. Pat. No. 8,602,124.

The present application is a reissue of U.S. Pat. No. 8,602,124, issued Dec. 10, 2013 from U.S. patent application Ser. No. 13/790,870, filed on Mar. 8, 2013. U.S. patent application Ser. No. 13,790,870 is a continuation of and claims priority under 35 U.S.C. [§120 on the pending] § 120 to U.S. patent application Ser. No. 13/759,813, filed on Feb. 5, 2013, now abandoned, the disclosure of which is incorporated by reference, which '813 application]. U.S. patent application Ser. No. 13/759,813 is a continuation-in-part of and claims priority under 35 U.S.C. [§120 on the pending] § 120 to U.S. patent application Ser. [Nos.] No. 12/980,329, filed on Dec. 29, 2010, [and] now U.S. Pat. No. 8,695,726. U.S. patent application Ser. No. 13/759,813 is also a continuation of and claims priority under 35 U.S.C. § 120 to U.S. patent application Ser. No. 13/466,870, filed on May 8, 2012, now U.S. Pat. No. 8,393,409, as well as]. U.S. patent application Ser. No. 13/759,813 also claims the benefit of priority under 35 [USC §119 on] U.S.C. § 119 to U.S. Provisional Patent Application Ser. Nos. 61/603,320, filed on Feb. 26, 2012, 61/682,915, filed on Aug. 14, 2012, and 61/734,539, filed on Dec. 7, 2012, the disclosures of which are incorporated by reference. [The present] U.S. patent application Ser. No. 13/790,870 is also a continuation-in-part of and claims priority under 35 U.S.C. [§120 on the pending] § 120 to U.S. patent application Ser. Nos. 12/980,329, filed on Dec. 29, 2010, now U.S. Pat. No. 8,695,726, and 13/466,870, filed on May 8, 2012, now U.S. Pat. No. 8,393,409, the disclosures of which are incorporated by reference. U.S. patent application Ser. No. 13/466,870 is also a continuation of and claims priority under 35 U.S.C. § 120 to U.S. patent application Ser. No. 13/337,075, filed on Dec. 24, 2011, now abandoned, and is a continuation-in-part of and claims priority under 35 U.S.C. § 120 to U.S. patent application Ser. No. 12/980,329, filed on Dec. 29, 2010, now U.S. Pat. No. 8,685,726. Additionally, the present application claims the benefit of priority under 35 [USC §119 for] U.S.C. § 119 to pending U.S. Provisional Patent Application Ser. Nos. 61/734,539, filed on Dec. 7, 2012, and 61/682,915, filed on Aug. 14, 2012, the disclosures of which are incorporated by reference.

FIELD OF THE DISCLOSURE

The present disclosure relates to electric tools for impacting in orthopedic applications, and, more particularly, to an electric motor driven tool for orthopedic impacting that is capable of providing controlled impacts to a broach or other end effector.

BACKGROUND

In the field of orthopedics, prosthetic devices, such as artificial joints, are often implanted or seated in a patient's body by seating the prosthetic device in a cavity of a bone of the patient. Typically, the cavity must be created before the prosthesis is seated or implanted, and traditionally, a physician removes and or compacts bone to form this cavity. A prosthesis usually includes a stem or other protrusion that serves as the particular portion of the prosthesis that is inserted into the cavity.

To create such a cavity, a physician may use a broach, which broach conforms to the shape of the stem of the prosthesis. Solutions known in the art include providing a handle with the broach, which handle the physician may grasp while hammering the broach into the implant area. Unfortunately, this approach is clumsy and unpredictable as being subject to the skill of the particular physician. This approach almost will always inevitably result in inaccuracies in the location and configuration of the cavity. Additionally, the surgeon suffers from fatigue in this approach due to the constant hammering. Finally, this approach carries with it the risk that the physician will damage bone structure in unintended areas.

Another technique for creating the prosthetic cavity is to drive the broach pneumatically, that is, by compressed air. This approach is disadvantageous in that it prevents portability of an impacting tool, for instance, because of the presence of a tethering air line, air being exhausted from a tool into the sterile operating field and fatigue of the physician operating the tool. Further, this approach, as exemplified in U.S. Pat. No. 5,057,112, does not allow for precise control of the impact force or frequency and instead functions very much like a jackhammer when actuated. Again, this lack of any measure of precise control makes accurate broaching of the cavity more difficult.

A third technique relies on computer-controlled robotic arms for creating the cavity. While this approach overcomes the fatiguing and accuracy issues, it suffers from having a very high capital cost and additionally removes the tactile feedback that a surgeon can get from a manual approach.

A fourth technique relies on the author's own prior disclosures to use a linear compressor to compress air on a single stroke basis and then, after a sufficient pressure is created, to release the air through a valve and onto a striker. This then forces the striker to travel down a guide tube and impact an anvil, which holds the broach and or other surgical tool. This invention works quite well, but, in the process of testing it, does not allow for a simple method to reverse the broach should it become stuck in the soft tissue. Further, the pressure of the air results in large forces in the gear train and linear motion converter components, which large forces lead to premature wear on components.

Consequently, there exists a need for an impacting tool that overcomes the various disadvantages of the prior art.

SUMMARY OF THE INVENTION

In view of the foregoing disadvantages of the prior art, an electric motor-driven orthopedic impacting tool configured to include all the advantages of the prior art and to overcome the drawbacks inherent therein is provided. The tool may be used by orthopedic surgeons for orthopedic impacting in hips, knees, shoulders and the like. The tool is capable of holding a broach, chisel, or other end effector and gently tapping the broach, chisel or other end effector into the cavity with controlled percussive impacts, resulting in a

better fit for the prosthesis or the implant. Further, the control afforded by such an electrically manipulated broach, chisel, or other end effector allows adjustment of the impact settings according to a particular bone type or other profile of a patient. The tool additionally enables proper seating or removal of the prosthesis or the implant into or out of an implant cavity and advantageously augments the existing surgeon's skill in guiding the instrument.

In an embodiment, an electric motor-driven orthopedic impacting tool comprises a power source (such as a battery), a motor, a control means, a housing, a method for converting the rotary motion of the motor to a linear motion (hereafter referred to as a linear motion converter), at least one reducing gear, a striker, a detent and an energy storage means, which energy storage means can include either compressed air or a vacuum. The tool may further include an LED, a handle portion with at least one handgrip for the comfortable gripping of the tool, an adapter configured to accept a surgical tool, a battery and at least one sensor. At least some of the various components are preferably contained within the housing. The tool is capable of applying cyclic impact forces on a broach, chisel, or other end effector, or an implant and of finely tuning an impact force to a plurality of levels.

In a further embodiment, the handle may be repositionable or foldable back to the tool to present an inline tool wherein the surgeon pushes or pulls on the tool co-linearly with the direction of the broach. This has the advantage of limiting the amount of torque the surgeon may put on the tool while it is in operation. In a further refinement of the hand grip, there may be an additional hand grip for guiding the surgical instrument and providing increased stability during the impacting operation.

In a further embodiment, the broach, chisel or other end effector can be rotated to a number of positions while still maintaining axial alignment. This facilitates the use of the broach for various anatomical presentations during surgery.

In a further embodiment, the energy storage means comprises a chamber, which is under at least a partial vacuum during a portion of an impact cycle.

In a further embodiment the linear motion converter uses one of a slider crank, linkage mechanism, cam, screw, rack and pinion, friction drive or belt and pulley.

In an embodiment, the linear motion converter and rotary motor may be replaced by a linear motor, solenoid or voice coil motor.

In an embodiment, the tool further comprises a control means, which control means includes an energy adjustment element, and which energy adjustment element may control the impact force of the tool and reduce or avoid damage caused by uncontrolled impacts. The energy may be regulated electronically or mechanically. Furthermore, the energy adjustment element may be analog or have fixed settings. This control means allows for the precise control of the broach machining operation.

In an embodiment, an anvil of the tool includes at least one of two points of impact and a guide that constrains the striker to move in a substantially axial direction. In operation, the movement of the striker along the guide continues in the forward direction. A reversing mechanism can be used to change the point of impact of the striker and the resulting force on the surgical tool. Use of such a reversing mechanism results in either a forward or a rearward force being exerted on the anvil and/or the broach or other surgical attachment. As used in this context, "forward direction" connotes movement of the striker toward a broach, chisel or patient, and "rearward direction" connotes movement of the

striker away from the broach, chisel or patient. The selectivity of either bidirectional or unidirectional impacting provides flexibility to a surgeon in either cutting or compressing material within the implant cavity in that the choice of material removal or material compaction is often a critical decision in a surgical procedure. Furthermore, it was discovered in the use of the author's prior disclosure that the tool would often get stuck during the procedure and that the method of reversal in that tool was insufficient to dislodge the surgical implement. This new embodiment overcomes these limitations. In an embodiment the impact points to communicate either a forward or rearward force are at least two separate and distinct points.

In an embodiment the anvil and the adapter comprise a single element, or one may be integral to the other.

In an embodiment the tool is further capable of regulating the frequency of the striker's impacting movement. By regulating the frequency of the striker, the tool may, for example, impart a greater total time-weighted percussive impact, while maintaining the same impact magnitude. This allows for the surgeon to control the cutting speed of the broach or chisel. For example, the surgeon may choose cutting at a faster rate (higher frequency impacting) during the bulk of the broach or chisel movement and then slow the cutting rate as the broach or chisel approaches a desired depth. In typical impactors, as shown in U.S. Pat. No. 6,938,705, as used in demolition work, varying the speed varies the impact force, making it impossible to maintain constant (defined as $\pm 20\%$) impact energy in variable speed operation.

In an embodiment the direction of impacting is controlled by the biasing force placed by a user on the tool. For example, biasing the tool in the forward direction gives forward impacting and biasing the tool in the rearward direction gives rear impacting.

In an embodiment the tool may have a lighting element to illuminate a work area and accurately position the broach, chisel, or other end effector on a desired location on the prosthesis or the implant.

In an embodiment the tool may also include a feedback system that warns the user when a bending or off-line orientation beyond a certain magnitude is detected at a broach, chisel, or other end effector or implant interface.

In an embodiment the tool may also include a detent that retains the striker and which may be activated by a mechanical or electrical means such that the energy per impact from the tool to the surgical end effector is increased. In an embodiment, the characteristics of this detent are such that within 30% of striker movement, the retention force exerted by the detent on the striker is reduced by 50%.

These together with other aspects of the present disclosure, along with the various features of novelty that characterize the present disclosure, are pointed out with particularity in the claims annexed hereto and form a part of the present disclosure. For a better understanding of the present disclosure, its operating advantages, and the specific objects attained by its uses, reference should be made to the accompanying drawings and detailed description in which there are illustrated and described exemplary embodiments of the present disclosure.

DESCRIPTION OF THE DRAWINGS

The advantages and features of the present invention will become better understood with reference to the following detailed description and claims taken in conjunction with the

5

accompanying drawings, wherein like elements are identified with like symbols, and in which:

FIG. 1 shows a perspective view of an orthopedic impacting tool in accordance with an exemplary embodiment of the present disclosure in which a motor, linear motion converter, and vacuum as energy storage means are used;

FIG. 2 shows an exemplary position of the piston wherein the vacuum has been created;

FIG. 3 shows the striker being released and the striker moving towards impacting the anvil in a forward direction;

FIG. 4 shows the striker being released and the striker moving such that the anvil will be impacted in a reverse direction;

FIG. 5 shows the vacuum piston moving back towards a first position and resetting the striker;

FIG. 6 shows an exemplary embodiment of a tool in which a compression chamber is used to create an impacting force;

FIG. 7 shows an exemplary embodiment of a tool in which a valve is used to adjust the energy of the impact of the striker;

FIG. 8 shows an exemplary embodiment of a tool in which the striker imparts a surface imparting a rearward force on the anvil;

FIG. 9 shows an exemplary embodiment of a tool in which the striker imparts a forward acting force on the anvil; and

FIG. 10 shows a comparison of the force vs. time curve between a sharp impact and a modified impact using a compliance mechanism in accordance with an exemplary embodiment of the present disclosure.

DETAILED DESCRIPTION OF THE DISCLOSURE

The best mode for carrying out the present disclosure is presented in terms of its preferred embodiments, herein depicted in the accompanying figures. The preferred embodiments described herein detail for illustrative purposes are subject to many variations. It is understood that various omissions and substitutions of equivalents are contemplated as circumstances may suggest or render expedient, but are intended to cover the application or implementation without departing from the spirit or scope of the present disclosure.

The terms "a" and "an" herein do not denote a limitation of quantity, but rather denote the presence of at least one of the referenced items.

The present disclosure provides an electric motor-driven orthopedic impacting tool with controlled percussive impacts. The tool includes the capability to perform single and multiple impacts as well as impacting of variable and varying directions, forces and frequencies. In an embodiment the impact force is adjustable. In another embodiment a detent may be provided, which detent facilitates the generation of a higher energy impact. In yet another embodiment the impact is transferred to a broach, chisel, or other end effector connected to the tool.

The tool may further include a housing. The housing may securely cover and hold at least one component of the tool. In an embodiment, the housing contains a motor, at least one reducing gear, a linear motion converter, a gas chamber, a striker, a force adjuster, a control means, an anvil, a forward impact surface and a different surface for rearward impact.

The tool further may include a handle portion with at least one hand grip for comfortable and secure holding of the tool while in use, and an adapter, a battery, a positional sensor,

6

a directional sensor, and a torsional sensor. The tool may further comprise a lighting element such as an LED to provide light in the work area in which a surgeon employs the tool. The anvil may be coupled to a broach, chisel or other end effector through the use of an adapter, which adapter may have a quick connect mechanism to facilitate rapid change of different broaching sizes. The anvil may further include a locking rotational feature to allow the broach to be presented to and configured at different anatomical configurations without changing the orientation of the tool in the surgeon's hands.

Referring now to FIGS. 1 through 5, in an embodiment, the linear motion converter 12 comprises a slider crank mechanism, which slider crank is operatively coupled to the motor 8 and reducing gears 7. The tool further comprises a vacuum chamber 23 that accepts a piston 24 which may be actuated by the linear motion converter 12. It will be apparent that the piston 24 may be actuated in more than one direction. The vacuum is created in the vacuum chamber 23 by the movement of piston 24 away from striker 25. The vacuum created in the vacuum chamber 23 is defined as a pressure of less than 9 psia for at least a portion of the operational cycle.

In an embodiment, the motor 8 of the tool causes the linear motion converter 12 to move, which pulls a vacuum on the face of the striker 25 and creates at least a partial vacuum in the vacuum chamber 23, as is shown in FIG. 2. The piston 24 continues to move increasing the size of the vacuum chamber 23 until it hits a forward portion of the striker 25 (i.e., a portion of the strike that is proximate to the end effector or patient), which dislodges the striker 25 from its detent 10 and allows it to rapidly accelerate towards the end of the tool that is proximate to the end effector or patient. In an embodiment, the detent may be mechanical, electrical, or a combination thereof, with the preferred detent shown in the figures as a magnet. A characteristic of the detent 10 is that once the detent 10 is released or overcome, the retention force of the detent 10 on the striker 25 reduces by at least 50% within the first 30% movement of the striker 25. The impact of the striker 25 on the anvil 14 communicates a force to the adapter 1 and the broach, chisel or other orthopedic instrument.

In an embodiment, the direction of the force on the anvil is controlled by the user's (such as a surgeon) force on the tool and a stroke limiter 13. It has been determined that prior art tools may occasionally get stuck in a cavity and the impact of the striker in the aforementioned paragraph may be insufficient to dislodge the tool. In this present embodiment, when the tool is being pulled away from the cavity, the striker 25 will not impact the anvil 14, but will impact an alternate surface and thereby communicate a rearward force on the anvil 14. This impact surface is shown in an exemplary embodiment as actuation pin 27. Actuation pin 27 communicates a force to lever arm 17, which communicates a rearward force on the anvil 14, and specifically on the anvil retract impact surface 26. This embodiment has the unexpected benefit of easily dislodging tools and instruments that have become stuck in a surgical cavity, while retaining all the benefits of the existing tool in terms of precision-controlled impacting. Thus, a further advantage of this tool was discovered as it can be seen that the surgeon can control the direction of the impacting by a bias that he or she may place on the tool and, in so doing, can reduce the likelihood of the broach, chisel or other end effector from getting stuck in a patient or surgical cavity.

In a further embodiment, an electromagnet may be incorporated as the detent 10 and released at an appropriate point

7

in the operation cycle to allow the striker **25** to impact the anvil **14**. Once the striker **25** has been released from the detent **10**, the air pressure on the rearward side of the striker **25**, propels it forward to impact the anvil **14** or other strike surface. The resultant force may be communicated through an end of the anvil **14** that is proximate to the anvil forward impact surface **16** and, optionally, through the adapter **1** to which a broach, chisel, or other end effector for seating or removing an implant or prosthesis may be attached.

The striker guide **11** may also have striker guide vent holes **20**, which allow the air in front of the striker **25** to escape, thus increasing the impact force of the striker **25** on the anvil **14**. The striker guide vent holes **20** may vent within the cavity of the tool body, thus creating a self-contained air cycle preventing air from escaping from the tool and allowing for better sealing of the tool. The position and the size of the striker guide vent holes **20** can also be used to regulate the impact force. Further, it was unexpectedly found that adding the striker guide vent holes **20** increases the impact force of the striker **25** on the anvil **14**.

In an embodiment, as the piston **24** continues through its stroke it moves towards the rear direction, which movement brings it in contact with rear striker face **28** of striker **25** and moves it towards the rear of the tool. This allows the detent **10** to lock or retain the striker **25** in position for the next impact. The piston **24** completes its rearward stroke and preferably activates a sensor **22** that signals the motor **8** to stop such that the piston **24** rests at or near bottom dead center of the vacuum chamber **23**. The vacuum chamber **23** preferably has a relief or check valve **9** or other small opening, which, in an embodiment, is part of the piston **24**. The valve **9** may also be located at other points in the vacuum chamber **23** and allows for any air which may have accumulated in the vacuum chamber **23** to be purged out of the vacuum chamber **23** during each cycle. In a further embodiment this valve effect could be accomplished with a cup seal instead of an o-ring seal. This ensures that approximately atmospheric pressure is present in the vacuum chamber **23** at a starting point in the operational cycle, thus ensuring that each impact utilizes the same amount of energy, as is important in orthopedic impacting for at least the reason that it assures of a substantially consistent force and impact rate in multi-impact situations. Thus, in one complete cycle, a forward or a rearward impacting force may be applied on the broach, chisel, or other end effector, or on the implant or prosthesis.

In a further embodiment, the motor **8** of the tool causes the linear motion converter **12** to move the piston **24** until the piston **24** moves a sufficient distance such that the forward portion of the piston impacts a portion of the striker and overcomes the detent **10** that retains the striker in the rear position. Once the striker has been released from the detent **10**, the vacuum in the vacuum chamber **23** exerts a force on the striker, which accelerates the striker, causing the striker to slide axially down a cavity internal to the tool housing and strike the anvil forward impact surface **16**. In FIG. **3**, the anvil forward impact surface **16** causes a forward movement of the anvil **14** and/or tool holder, and, in FIG. **4**, the anvil retract impact surface **26** causes a rearward movement of the anvil **14** and/or tool holder. The resultant force is communicated through an end of the anvil **14** that is proximate to the anvil forward impact surface **16** and, optionally, through the adapter **1** to which a broach, chisel, or other end effector for seating or removing an implant or prosthesis may be attached.

In another embodiment, the impact force may be generated using a compressed air chamber **5** in conjunction with

8

a piston **6** and striker **4**, as shown in FIGS. **6** through **9**. In this embodiment, the motor **8** of the tool causes the linear motion converter **12** to move the piston **6** until sufficient pressure is built within the compressed air chamber **5** that is disposed between the distal end of the piston **6** and the proximate end of the striker **4** to overcome a detent **10** that otherwise retains the striker **4** in a rearward position and or the inertia and frictional force that holds the striker **4** in that rearward position. Once this sufficient pressure is reached, an air passageway **19** is opened and the air pressure accelerates the striker **4**, which striker **4** slides axially down a cavity and strikes the anvil **14**. The air passageway **19** has a cross sectional area of preferably less than 50% of the cross sectional area of the striker **4** so as to reduce the amount of retaining force required from detent **10**. The resultant force is communicated through the end of the anvil **14** that is proximate to the anvil forward impact surface **16** and, optionally, through the adapter **1** to which a broach, chisel, or other device for seating or removing an implant or prosthesis may be attached.

As the piston **6** continues through its stroke, it moves towards the rear direction, pulling a slight vacuum in compressed air chamber **5**. This vacuum may be communicated through an air passageway **19** to the back side of the striker **4**, creating a returning force on the striker **4**, which returning force causes the striker **4** to move in a rear direction, i.e., a direction away from the point of impact of the striker **4** on the anvil forward impact surface **16**. In the event that an adapter **1** is attached to the anvil **14**, a force may be communicated through the adapter **1** to which the broach, chisel, or other end effector for seating or removing an implant or prosthesis is attached.

Further, when the tool is being pulled away from the cavity, the striker **4** will not impact the anvil **14**, but may instead impact an alternate surface and thereby communicate a rearward force on the anvil **14**. This impact surface is shown in an exemplary embodiment as actuation pin **27**. Actuation pin **27** communicates a force to lever arm **17**, which communicates a rearward force on the anvil **14**, and specifically on the anvil retract impact surface **26**.

The tool may further facilitate controlled continuous impacting, which impacting is dependent on a position of a start switch (which start switch may be operatively coupled to the power source or motor, for example.) For such continuous impacting, after the start switch is activated, and depending on the position of the start switch, the tool may go through complete cycles at a rate proportional to the position of the start switch, for example. Thus, with either single impact or continuous impacting operational modes, the creation or shaping of the surgical area is easily controlled by the surgeon.

A sensor **22** coupled operatively to the control means **21** may be provided to assist in regulating a preferred cyclic operation of the linear motion converter **12**. For example, the sensor **22** may communicate at least one position to the control means **21**, allowing the linear motion converter **12** to stop at or near a position in which at least 75% of a full power stroke is available for the next cycle. This position is referred to as a rest position. This has been found to be advantageous over existing tools in that it allows the user to ensure that the tool impacts with the same amount of energy per cycle. Without this level of control, the repeatability of single cycle impacting is limited, reducing the confidence the surgeon has in the tool.

The tool is further capable of tuning the amount of impact energy per cycle by way of, for example, an energy control element **18**. By controlling the impact energy the tool can

avoid damage caused by uncontrolled impacts or impacts of excessive energy. For example, a surgeon may reduce the impact setting in the case of an elderly patient with osteoporosis, or may increase the impact setting for more resilient or intact athletic bone structures.

In an embodiment, the energy control element **18** preferably comprises a selectable release setting on the detent **10** that holds the striker **25**. It will be apparent that the striker **25** will impact the anvil **14** with greater energy in the case where the pressure needed to dislodge the striker **25** from the detent **10** is increased. In another embodiment, the detent **10** may comprise an electrically controlled element. The electrically controlled element can be released at different points in the cycle, thus limiting the size of the vacuum chamber **23**, which is acting on the striker **25**. In an embodiment, the electrically controlled element is an electromagnet.

In another embodiment, the vacuum chamber **23** or compressed air chamber **5** may include an energy control element **18**, which takes the form of an adjustable leak, such as an adjustable valve. The leakage reduces the amount of energy accelerating the striker **4** or **25**, thus reducing the impact energy on the anvil **14**. In the case of the adjustable leak, adjusting the leak to maximum may give the lowest impact energy from the striker **4** or **25**, and adjusting to shut the leak off (zero leak) may give the highest impact energy from the striker **4** or **25**.

The tool may further comprise a compliance means inserted between the striker **4** or **25** and the surgical end effector, which purpose is to spread the impact force out over a longer time period, thus achieving the same total energy per impact, but at a reduced force. This can be seen clearly as a result of two load cell tests on the instrument as shown in FIG. **10**. This type of compliance means can limit the peak force during impact to preclude such peaks from causing fractures in the patient's bone. In a further embodiment, this compliance means may be adjustable and in a still further embodiment the compliance means may be inserted between striker **4** or **25** and the anvil **14** or surgical tool. In this manner and otherwise, the tool facilitates consistent axial broaching and implant seating. Preferably, the compliance means increases the time of impact from the striker to at least 4 milliseconds and preferable 10 milliseconds. This contrasts to impacting in which a very high force is generated due to the comparatively high strengths of the striker **4** or **25** and the anvil **14** (both steel, for example). Preferably, the compliance means comprises a resilient material such as urethane, rubber or other elastic material that recovers well from impact and imparts minimal damping on the total energy.

In a further embodiment, the adapter **1** may comprise a linkage arrangement or other adjustment means such that the position of the broach, chisel or other end effector can be modified without requiring the surgeon to rotate the tool. In an embodiment, the adapter **1** may receive a broach for anterior or posterior joint replacement through either an offset mechanism or by a rotational or pivotal coupling between the tool and the patient. The adapter **1** may thereby maintain the broach or surgical end effector in an orientation that is parallel or co-linear to the body of the tool and the striker **25**. The adapter **1** may also comprise clamps, a vice, or any other fastener that may securely hold the broach, chisel, or other end effector during operation of the tool.

In use, a surgeon firmly holds the tool by the handle grip or grips and utilizes light emitted by the LED to illuminate a work area and accurately position a broach, chisel or other end effector that has been attached to the tool on a desired location on the prosthesis or implant. The reciprocating

movement imparted by the tool upon the broach, chisel or other end effector allows for shaping a cavity and for seating or removal of a prosthesis.

The tool disclosed herein provides various advantages over the prior art. It facilitates controlled impacting at a surgical site, which minimizes unnecessary damage to a patient's body and which allows precise shaping of an implant or prosthesis seat. The tool also allows the surgeon to modulate the direction, force and frequency of impacts, which improves the surgeon's ability to manipulate the tool. The force and compliance control adjustments of the impact settings allow a surgeon to set the force of impact according to a particular bone type or other profile of a patient. The improved efficiency and reduced linear motion converter loads allow use of smaller batteries and lower cost components. The tool thereby enables proper seating or removal of the prosthesis or implant into or out of an implant cavity.

The foregoing descriptions of specific embodiments of the present disclosure have been presented for purposes of illustration and description. They are not intended to be exhaustive or to limit the present disclosure to the precise forms disclosed, and obviously many modifications and variations are possible in light of the above teaching. The exemplary embodiment was chosen and described in order to best explain the principles of the present disclosure and its practical application, to thereby enable others skilled in the art to best utilize the disclosure and various embodiments with various modifications as are suited to the particular use contemplated.

What is claimed is:

[1. An orthopedic impacting tool for striking an object, the tool comprising:

a motor;
a linear motion converter;
an energy storage means;
a detent;

a control means;
an adapter, said adapter capable of holding a broach, chisel or other surgical implement; and
a striker, said striker capable of impacting at least two distinct impact surfaces, wherein a first impact surface moves said adapter forward and a second impact surface moves said adapter rearward,

wherein said control means directs said motor to store an energy in said energy storage means and said energy storage means thereafter releases the energy onto said striker causing said striker to move from a first position to a second position such that said striker is capable of imparting a force upon said adapter in a direction that is dependent at least in part on which surface said striker impacts.]

[2. The tool as claimed in claim **1**, wherein said impact surface being impacted is controlled by a bias that a user puts on the tool.]

[3. The tool as claimed in claim **1**, wherein said energy storage means includes a chamber operating at less than 9 psia or a pressure in excess of 50 psia at or near the point of peak energy storage.]

[4. The tool as claimed in claim **1**, wherein said detent retains said striker in said first position until said detent is released or overcome thus allowing said energy storage means to release the energy onto said striker.]

[5. The tool as claimed in claim **1**, wherein said energy storage means further comprises a valve.]

11

[6. The tool as claimed in claim 1, wherein the tool further comprises an energy control element, said energy control element used to adjust the impact energy said striker exerts on said adapter.]

[7. The tool as claimed in claim 1, wherein the tool further comprises a stroke limiter, said stroke limiter limiting a stroke of said adapter to less than fifty percent of a stroke of said striker.]

8. *A portable, battery powered surgical impactor for striking an object with a repeatable, controlled striking force to impel a surgical implement in one of at least two opposing directions, the impactor comprising:*

a rotational drive mechanism;

a linear motion converter configured to convert an output of the rotational drive mechanism to a linear motion; an integral battery source powering the rotational drive mechanism;

an energy storage device configured to receive energy from the linear motion converter;

an energy controller configured to control storage and release of the energy from the energy storage device to deliver the repeatable, controlled striking force to an adapter, the adapter configured to receive the surgical implement for interfacing the object;

a surface of a striker operable to impact a first surface and a different second surface of an anvil responsive to the repeatable, controlled striking force delivered thereto, the impact of the surface of the striker on the first surface impelling the adapter in a first direction and the impact of the surface of the striker on the second surface impelling the adapter in a direction opposite the first direction; and

a detent mechanism configured to retain the striker in position.

9. *The impactor of claim 8, wherein a selection of a direction of impact on the first and second surfaces is based upon a user bias force applied to the impactor.*

10. *The impactor of claim 9, wherein the user bias force in a direction of the object causes the surface of the striker to impact the first surface.*

11. *The impactor of claim 9, wherein the user bias force in a direction away from the object causes the surface of the striker to impact the second surface.*

12. *The impactor of claim 8, wherein the energy storage device includes a chamber operating between 0 and 9 psia for a portion of a storage cycle.*

13. *The impactor of claim 8, wherein the energy storage device includes a chamber that is under at least a partial vacuum when the surface of the striker impacts the first surface to impel the surgical implement in the first direction.*

14. *The impactor of claim 8, wherein the energy storage device is a compressed air storage chamber.*

12

15. *The impactor of claim 8, further comprising: an energy adjustment mechanism to adjust the striking force the striker delivers to the adapter in accordance with a patient profile.*

16. *The impactor of claim 8, wherein upon release of the detent mechanism, a retention force of the detent mechanism on the striker is reduced by at least fifty percent within a first thirty percent of a stroke of the striker.*

17. *The impactor of claim 8, wherein the striker is operably linked to the adapter by the impact of the surface of the striker on the first and second surfaces of the anvil.*

18. *The impactor of claim 8, wherein the adapter is configured to releasably connect to the surgical implement.*

19. *The impactor of claim 8, wherein the striker moves in a substantially axial direction along a guide portion having openings therein for venting of air during operation.*

20. *The impactor of claim 18, further comprising: a sensor operably linked to the energy controller to regulate the linear motion converter to a preferred cyclic operation.*

21. *The impactor of claim 20, wherein the sensor detects a position of the linear motion converter to limit a stroke to a percentage less than full power.*

22. *A portable, battery powered surgical impactor for striking an object with a repeatable, controlled striking force to impel a surgical implement in one of at least two opposing directions, the impactor comprising:*

a rotational drive mechanism;

a linear motion converter configured to convert an output of the rotational drive mechanism to a linear motion; an integral battery source powering the rotational drive mechanism;

an energy controller configured to control storage and release of energy output from the linear motion converter to an energy storage device to produce the repeatable, controlled striking force;

an adapter having a mount configured to receive the surgical implement;

a surface of a striker operable to impact a first surface and a different second surface of an anvil, responsive to the repeatable, controlled striking force delivered thereto, the impact of the surface of the striker on the first surface impelling the adapter in a first direction and the impact of the surface of the striker on the second surface impelling the adapter in a direction opposite the first direction; and

a detent mechanism configured to retain the striker in position.

23. *The impactor of claim 22, wherein a user bias force in a direction away from the object causes the surface of the striker to impact the second surface.*

24. *The impactor of claim 22, wherein a user bias force in a direction of the object causes the surface of the striker to impact the first surface.*

* * * * *

UNITED STATES PATENT AND TRADEMARK OFFICE
CERTIFICATE OF CORRECTION

PATENT NO. : RE46,954 E
APPLICATION NO. : 14/850639
DATED : July 17, 2018
INVENTOR(S) : Pedicini

Page 1 of 1

It is certified that error appears in the above-identified patent and that said Letters Patent is hereby corrected as shown below:

In the Specification

At Column 1, under the heading "CROSS-REFERENCE TO RELATED APPLICATIONS," please replace Lines 15-23 (approx.), with the following:

--NOTICE: More than one reissue application has been filed for the reissue of U.S. Patent No. 8,602,124 B2. The reissue applications are U.S. Reissue Patent Application Serial No. 17/140,443, filed on January 4, 2021, which is a continuation reissue of U.S. Reissue Patent Application Serial No. 15/677,933, filed on August 15, 2017, now U.S. Reissue Patent No. RE48,387, issued January 12, 2021, which is a continuation reissue of U.S. Reissue Patent Application Serial No. 14/850,588, filed on September 10, 2015, now U.S. Reissue Patent No. RE48,184 E, issued September 1, 2020, which together with U.S. Reissue Patent Serial No. 14/850,695, 14/850,674, 14/850,660, 14/850,639 (the present application), and 14/850,620, each filed on September 10, 2015, now U.S. Reissue Patent Nos. RE47,997 E, RE48,251 E, RE46,979 E, RE46,954 E, and RE47,963 E, respectively, issued May 19, 2020, October 13, 2020, August 7, 2018, July 17, 2018, and April 28, 2020, respectively, each of which ('933, '695, '674, '660, '639, '620, and '588) is a reissue application of U.S. Patent Application Serial No. 13/790,870, filed on March 8, 2013, now U.S. Patent No. 8,602,124 B2, issued December 10, 2013, which is a continuation of and--

Signed and Sealed this
Twenty-third Day of March, 2021



Drew Hirshfeld
Performing the Functions and Duties of the
Under Secretary of Commerce for Intellectual Property and
Director of the United States Patent and Trademark Office