

US00RE46926E

(19) **United States**
(12) **Reissued Patent**
Bly et al.

(10) **Patent Number:** **US RE46,926 E**
(45) **Date of Reissued Patent:** ***Jul. 3, 2018**

(54) **ADHERENT DEVICE WITH MULTIPLE
PHYSIOLOGICAL SENSORS**

(71) Applicant: **Medtronic Monitoring, Inc.**, San Jose,
CA (US)

(72) Inventors: **Mark J. Bly**, Falcon Heights, MN
(US); **Badri Amurthur**, Los Gatos, CA
(US); **Kristofer J. James**, Eagan, MN
(US); **Imad Libbus**, Saint Paul, MN
(US); **Yatheendhar D. Manicka**,
Woodbury, MN (US); **Scott T. Mazar**,
Woodbury, MN (US); **Jerry S. Wang**,
Edina, MN (US)

(73) Assignee: **Medtronic Monitoring, Inc.**,
Minneapolis, MN (US)

(*) Notice: This patent is subject to a terminal dis-
claimer.

(21) Appl. No.: **15/247,458**

(22) Filed: **Aug. 25, 2016**

Related U.S. Patent Documents

Reissue of:

(64) Patent No.: **8,818,481**
Issued: **Aug. 26, 2014**
Appl. No.: **13/647,284**
Filed: **Oct. 8, 2012**

U.S. Applications:

(63) Continuation of application No. 13/347,238, filed on
Jan. 10, 2012, now Pat. No. 8,285,356, which is a
continuation of application No. 12/209,273, filed on
Sep. 12, 2008, now Pat. No. 8,116,841.

(Continued)

(51) **Int. Cl.**
A61B 5/0408 (2006.01)
A61B 5/0402 (2006.01)
(Continued)

(52) **U.S. Cl.**
CPC **A61B 5/04087** (2013.01); **A61B 5/0006**
(2013.01); **A61B 5/0205** (2013.01);
(Continued)

(58) **Field of Classification Search**
CPC . **A61B 5/0205**; **A61B 5/02438**; **A61B 5/0537**;
A61B 2560/0468
(Continued)

(56) **References Cited**

U.S. PATENT DOCUMENTS

3,170,459 A 2/1965 Phipps et al.
3,370,459 A 2/1968 Arturo
(Continued)

OTHER PUBLICATIONS

3M Corporation, "3M Surgical Tapes—Choose the Correct Tape"
quicksheet (2004).*
(Continued)

Primary Examiner — Cary E Wehner

(57) **ABSTRACT**

An adherent device to monitor a patient for an extended period comprises a breathable tape. The breathable tape comprises a porous material with an adhesive coating to adhere the breathable tape to a skin of the patient. At least one electrode is affixed to the breathable tape and capable of electrically coupling to a skin of the patient. A printed circuit board is connected to the breathable tape to support the printed circuit board with the breathable tape when the tape is adhered to the patient. Electronic components electrically are connected to the printed circuit board and coupled to the at least one electrode to measure physiologic signals of the patient. A breathable cover and/or an electronics housing is disposed over the circuit board and electronic components and connected to at least one of the electronics components, the printed circuit board or the breathable tape.

27 Claims, 12 Drawing Sheets

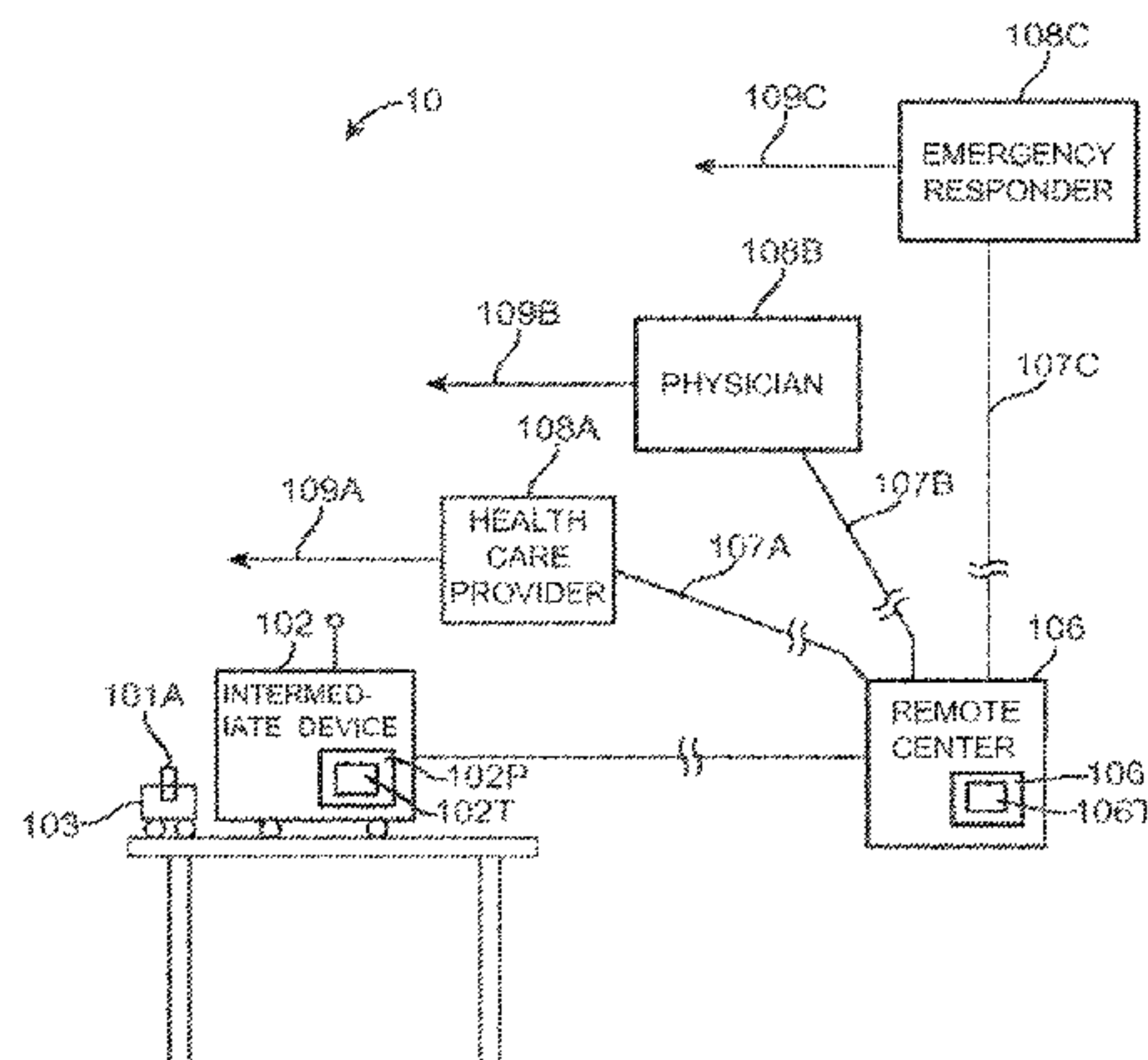
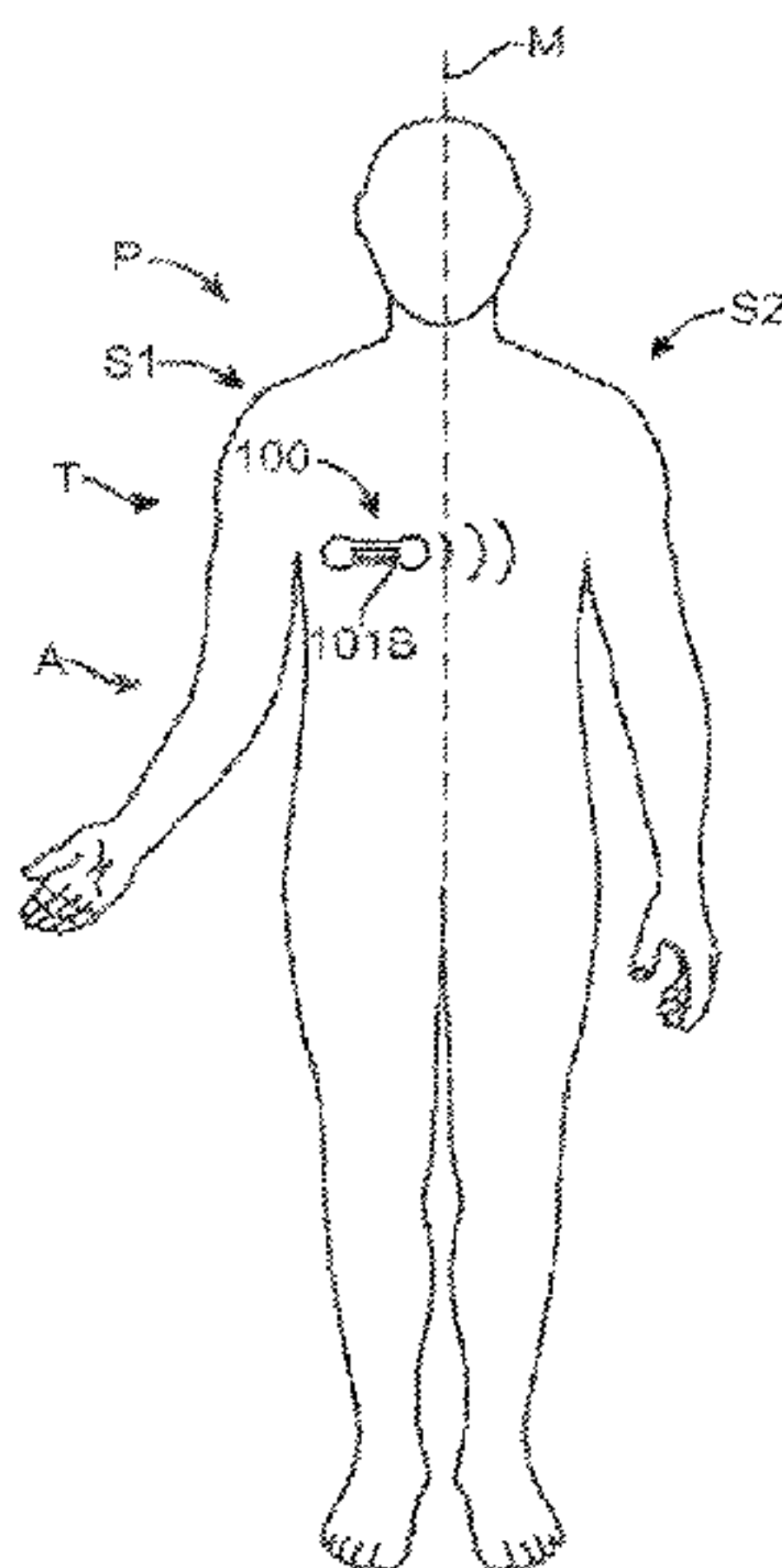

Related U.S. Application Data						
		4,300,575	A *	11/1981	Wilson	A61N 1/0456 607/152
(60)	Provisional application No. 60/972,629, filed on Sep. 14, 2007, provisional application No. 60/972,537, filed on Sep. 14, 2007, provisional application No. 61/055,645, filed on May 23, 2008, provisional application No. 61/055,666, filed on May 23, 2008.	4,674,511	A	6/1987	Cartmell	
		4,838,273	A	6/1989	Cartmell	
		4,955,381	A	9/1990	Way et al.	
		4,981,139	A	1/1991	Pfohl	
		5,080,099	A	1/1992	Way et al.	
		5,353,793	A	10/1994	Bornn	
		5,406,945	A *	4/1995	Riazzi et al.	600/394
(51)	Int. Cl.	5,511,553	A	4/1996	Segalowitz	
	<i>A61B 5/053</i> (2006.01)	5,544,661	A	8/1996	Davis et al.	
	<i>A61B 5/024</i> (2006.01)	5,558,638	A	9/1996	Evers et al.	
	<i>A61B 5/08</i> (2006.01)	5,710,376	A	1/1998	Weber	
	<i>A61B 5/00</i> (2006.01)	5,724,025	A	3/1998	Tavori	
	<i>A61N 1/04</i> (2006.01)	5,738,107	A *	4/1998	Martinsen et al.	600/547
	<i>G06F 19/00</i> (2018.01)	5,772,586	A	6/1998	Heinonen et al.	
	<i>A61B 5/046</i> (2006.01)	5,862,802	A	1/1999	Bird	
	<i>A61B 5/0464</i> (2006.01)	5,862,803	A *	1/1999	Besson et al.	600/508
	<i>A61B 5/0472</i> (2006.01)	6,047,203	A	4/2000	Sackner et al.	
	<i>A61B 5/0428</i> (2006.01)	6,117,077	A *	9/2000	Del Mar et al.	600/301
	<i>A61B 5/0205</i> (2006.01)	6,129,744	A	10/2000	Boute	
	<i>G16H 50/30</i> (2018.01)	6,225,901	B1	5/2001	Kail, IV	
	<i>A61B 5/021</i> (2006.01)	6,385,473	B1	5/2002	Haines et al.	
	<i>A61B 5/0245</i> (2006.01)	6,416,471	B1	7/2002	Kumar et al.	
	<i>A61B 5/0452</i> (2006.01)	6,453,186	B1	9/2002	Lovejoy et al.	
	<i>A61B 5/11</i> (2006.01)	6,454,707	B1	9/2002	Casscells et al.	
	<i>A61B 7/00</i> (2006.01)	6,527,711	B1	3/2003	Stivoric et al.	
	<i>A61N 1/365</i> (2006.01)	6,527,729	B1	3/2003	Turcott	
	<i>G16H 15/00</i> (2018.01)	6,546,285	B1	4/2003	Owen et al.	
(52)	U.S. Cl.	6,551,252	B2	4/2003	Sackner et al.	
	CPC	6,595,927	B2	7/2003	Pitts-Crick et al.	
	<i>A61B 5/02055</i> (2013.01); <i>A61B 5/02405</i> (2013.01); <i>A61B 5/046</i> (2013.01); <i>A61B 5/0428</i> (2013.01); <i>A61B 5/0464</i> (2013.01); <i>A61B 5/0472</i> (2013.01); <i>A61B 5/04085</i> (2013.01); <i>A61B 5/0535</i> (2013.01); <i>A61B 5/0537</i> (2013.01); <i>A61B 5/0806</i> (2013.01); <i>A61B 5/0809</i> (2013.01); <i>A61B 5/11</i> (2013.01); <i>A61B 5/1118</i> (2013.01); <i>A61B 5/443</i> (2013.01); <i>A61B 5/4869</i> (2013.01); <i>A61B 5/4875</i> (2013.01); <i>A61B 5/6801</i> (2013.01); <i>A61B 5/6833</i> (2013.01); <i>A61B 5/7275</i> (2013.01); <i>A61B 5/746</i> (2013.01); <i>A61B 7/00</i> (2013.01); <i>A61N 1/046</i> (2013.01); <i>A61N 1/0476</i> (2013.01); <i>A61N 1/0492</i> (2013.01); <i>G06F 19/3418</i> (2013.01); <i>G06F 19/3431</i> (2013.01); <i>G16H 50/30</i> (2018.01); <i>A61B 5/021</i> (2013.01); <i>A61B 5/02438</i> (2013.01); <i>A61B 5/02455</i> (2013.01); <i>A61B 5/0452</i> (2013.01); <i>A61B 5/053</i> (2013.01); <i>A61B 5/0816</i> (2013.01); <i>A61B 5/1116</i> (2013.01); <i>A61B 7/003</i> (2013.01); <i>A61B 2560/0412</i> (2013.01); <i>A61N 1/36521</i> (2013.01); <i>A61N 1/36535</i> (2013.01); <i>A61N 1/36542</i> (2013.01); <i>A61N 1/36592</i> (2013.01); <i>G06F 19/3487</i> (2013.01); <i>G16H 15/00</i> (2018.01)	6,605,038	B1	8/2003	Teller et al.	
		6,643,541	B2 *	11/2003	Mok et al.	600/546
		6,645,153	B2	11/2003	Kroll et al.	
		6,795,722	B2	9/2004	Sheraton et al.	
		6,814,706	B2 *	11/2004	Barton et al.	600/549
		6,821,249	B2	11/2004	Casscells, III et al.	
		6,881,191	B2 *	4/2005	Oakley et al.	600/483
		6,980,851	B2	12/2005	Zhu	
		7,020,508	B2	3/2006	Stivoric et al.	
		7,054,679	B2	5/2006	Hirsh	
		7,153,262	B2	12/2006	Stivoric et al.	
		7,273,454	B2	9/2007	Raymond et al.	
		7,382,247	B2 *	6/2008	Welch et al.	340/539.12
		7,515,043	B2	4/2009	Welch et al.	
		7,904,133	B2	3/2011	Gehman et al.	
		8,116,841	B2 *	2/2012	Bly et al.	600/391
		8,285,356	B2 *	10/2012	Bly et al.	600/391
		8,718,742	B2	5/2014	Beck et al.	
		8,818,481	B2	8/2014	Bly et al.	
		2002/0019586	A1	2/2002	Teller et al.	
		2002/0022786	A1	2/2002	Takehara et al.	
		2002/0180605	A1 *	12/2002	Ozguz et al.	340/573.1
		2003/0069510	A1	4/2003	Semler	
		2003/0092975	A1	5/2003	Samuel, III et al.	
		2003/0149349	A1 *	8/2003	Jensen	600/372
		2004/0122489	A1	6/2004	Mazar et al.	
		2005/0070778	A1	3/2005	Lackey et al.	
		2005/0113703	A1	5/2005	Farrington et al.	
		2005/0131288	A1	6/2005	Turner et al.	
		2005/0192488	A1 *	9/2005	Bryenton	A61B 5/02055 600/301
		2005/0245839	A1 *	11/2005	Stivoric et al.	600/549
		2005/0251004	A1 *	11/2005	Istvan et al.	600/395
(58)	Field of Classification Search	2006/0010090	A1	1/2006	Brockway et al.	
	USPC	2006/0031102	A1	2/2006	Teller et al.	
	600/391–393, 386, 372, 509, 547, 301	2006/0089679	A1	4/2006	Zhu et al.	
	See application file for complete search history.	2006/0122474	A1	6/2006	Teller et al.	
(56)	References Cited	2006/0155183	A1	7/2006	Kroecker et al.	
	U.S. PATENT DOCUMENTS	2006/0167374	A1	7/2006	Takehara et al.	
		2006/0224051	A1	10/2006	Teller et al.	
		2006/0238333	A1	10/2006	Welch et al.	
		2006/0264730	A1	11/2006	Stivoric et al.	
		2007/0021678	A1	1/2007	Beck et al.	
		2007/0038038	A1	2/2007	Stivoric et al.	
		2007/0069887	A1	3/2007	Welch et al.	
		2007/0082189	A1 *	4/2007	Gillette	428/304.4

(56)

References Cited

U.S. PATENT DOCUMENTS

2007/0208232 A1 9/2007 Kovacs A61B 5/02055
600/300
2007/0270678 A1* 11/2007 Fadem et al. 600/372
2008/0139953 A1* 6/2008 Baker et al. A61B 5/0006
600/509
2009/0132018 A1* 5/2009 DiUbaldo et al. 607/152
2010/0063365 A1 3/2010 Pisani et al.
2010/0081913 A1* 4/2010 Cross et al. 600/386
2010/0228113 A1 9/2010 Solosko et al.
2012/0029310 A1* 2/2012 Paquet et al. 600/301
2012/0310070 A1* 12/2012 Kumar et al. 600/391
2013/0253285 A1 9/2013 Bly et al.
2015/0073231 A1 3/2015 Beck et al.

OTHER PUBLICATIONS

Scapa Medical product listing and descriptions (2008) available at <http://www.caapana.com/productlist.jsp>; retrieved from U.S. Appl. No. 13/647,284.*

HRV Enterprises, LLC, "Heart Rate Variability Seminars", retrieved from U.S. Appl. No. 12/209,273.*

Scapa Medical product listing and descriptions (2008) available at <http://www.caapana.com/productlist.jsp> and <http://metplus.co.rs/pdf/prospekti/Samolepljivemedicinsketrake.pdf>; retrieved via WayBack Machine Aug. 29, 2013, 36 pp.

Draft Petition for Inter Partes Review of U.S. Pat. No. 8,818,481, dated Jan. 18, 2016, 69 pp. (To the best of Applicant's knowledge, this draft Petition was never filed. Personally identifying information of the Petitioner, Petitioner's Counsel, and Petitioner's Expert has been redacted.)

Donnay, "Human++ Wireless body-area networks (WBAN) for health monitoring applications," ESF Workshop on Wireless Sensor Networks, Apr. 1-2, 2004, 22 slides.

U.S. Appl. No. 60/940,072, filed by James C. Beck on May 24, 2007, 15 pp.

Prosecution History from U.S. Pat. No. 8,718,742, dated Aug. 31, 2012 through Mar. 14, 2014, 68 pp.

* cited by examiner

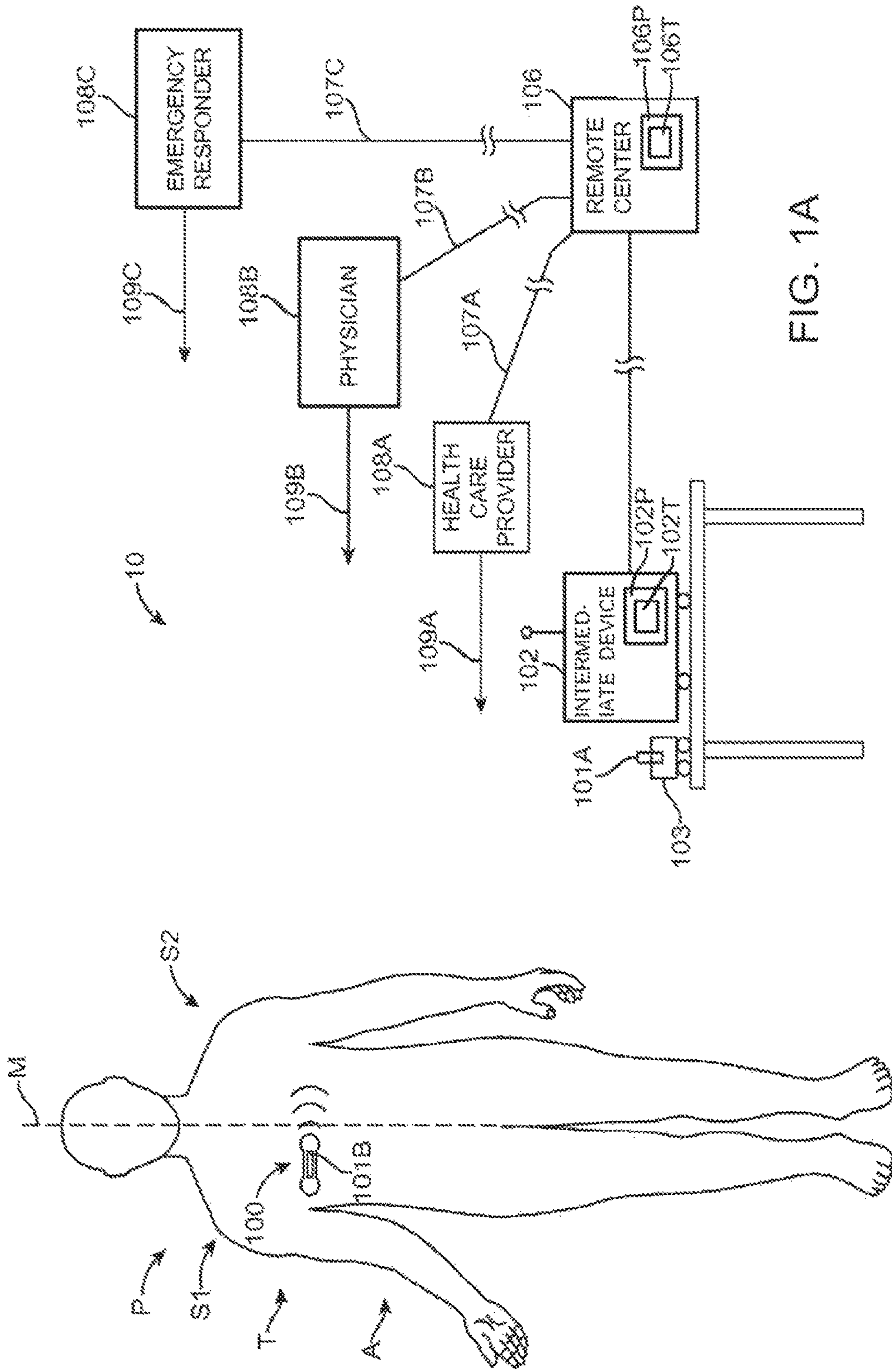

FIG. 1A

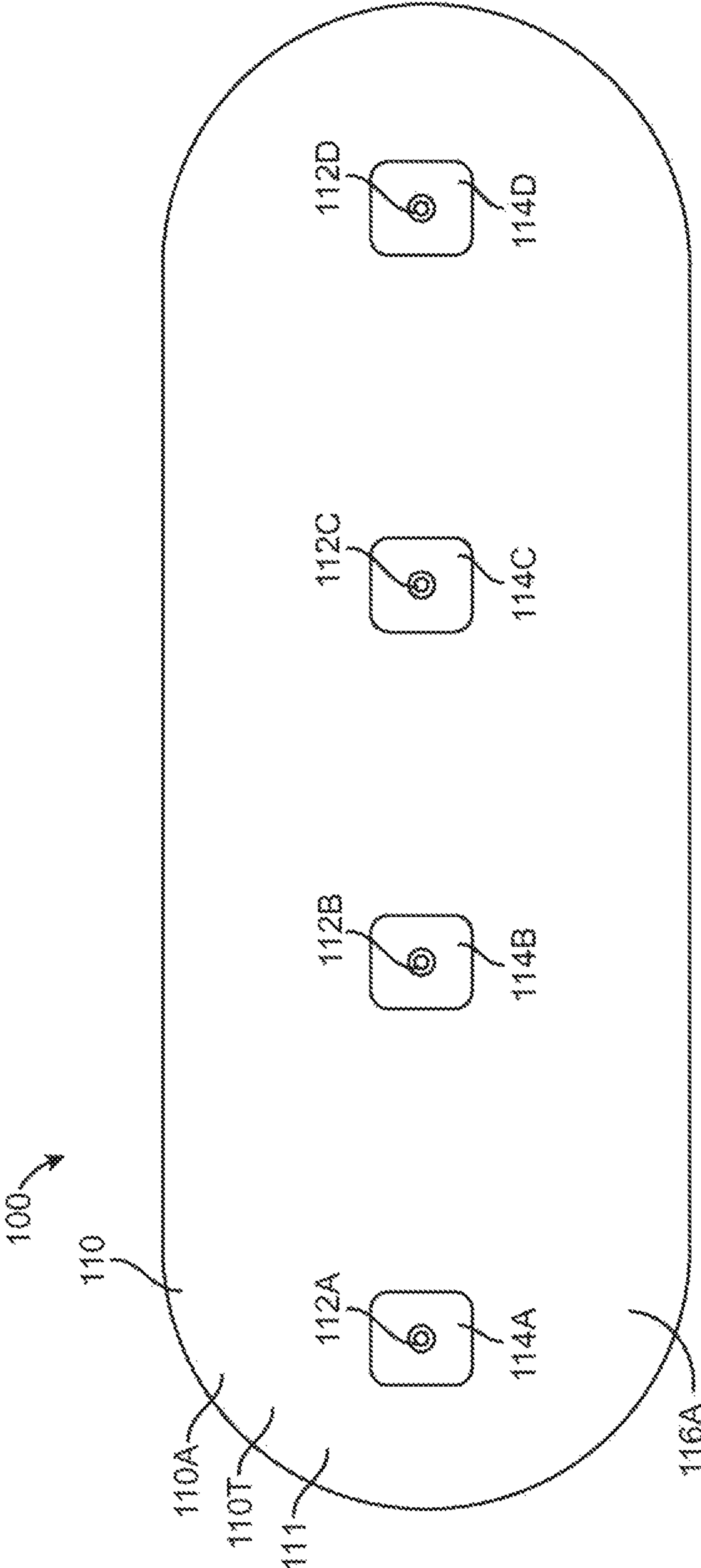

FIG. 1B

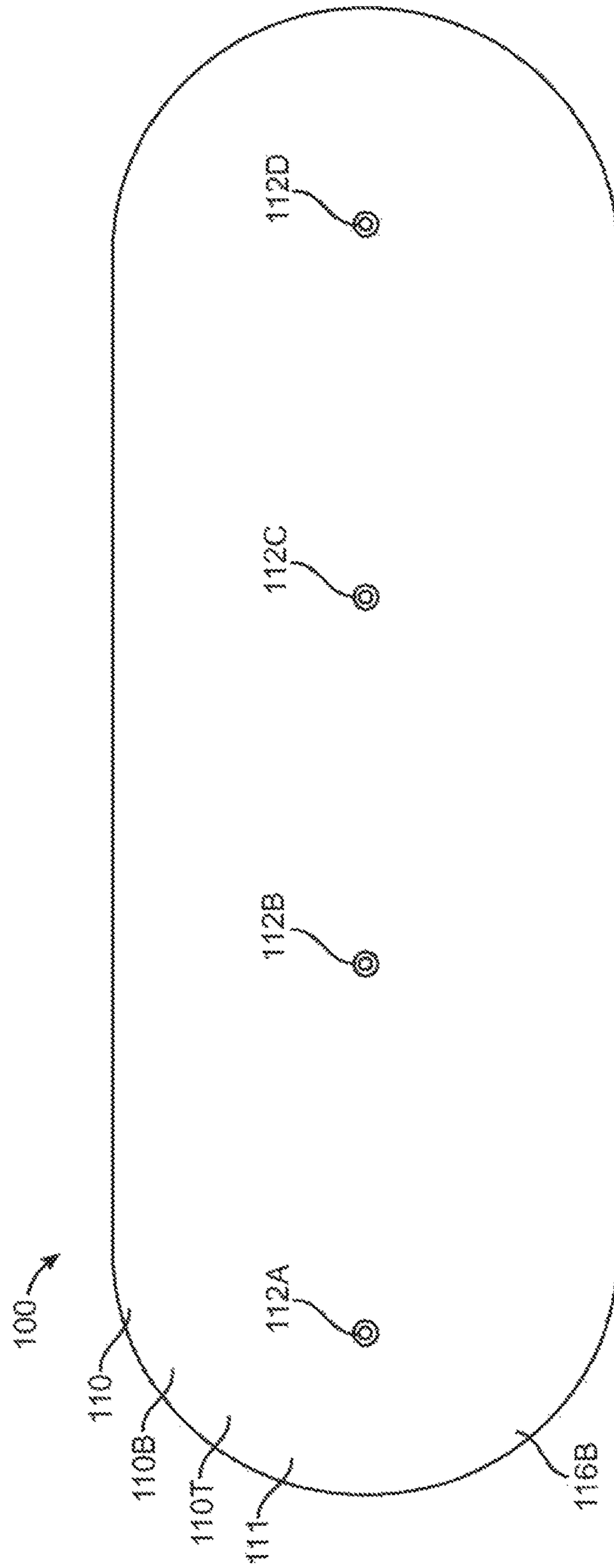

FIG. 1C

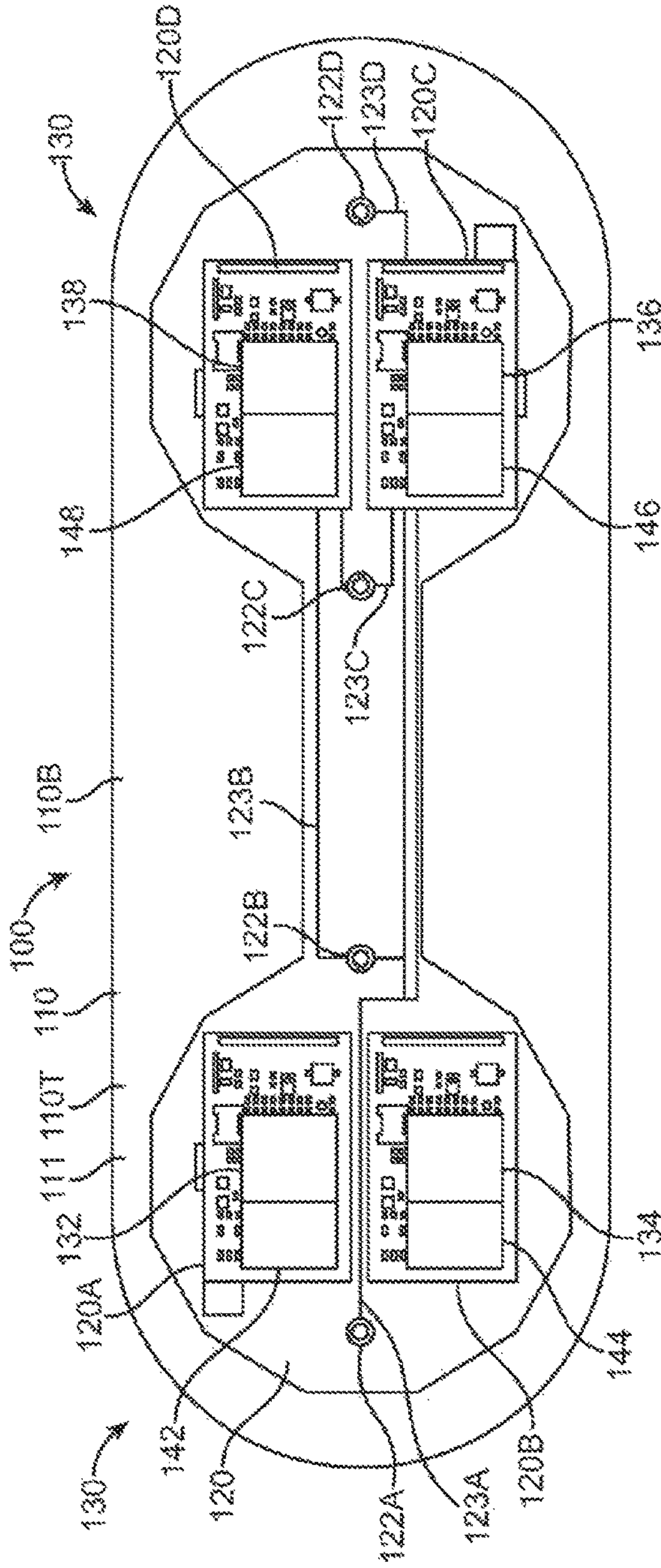

FIG. 1D

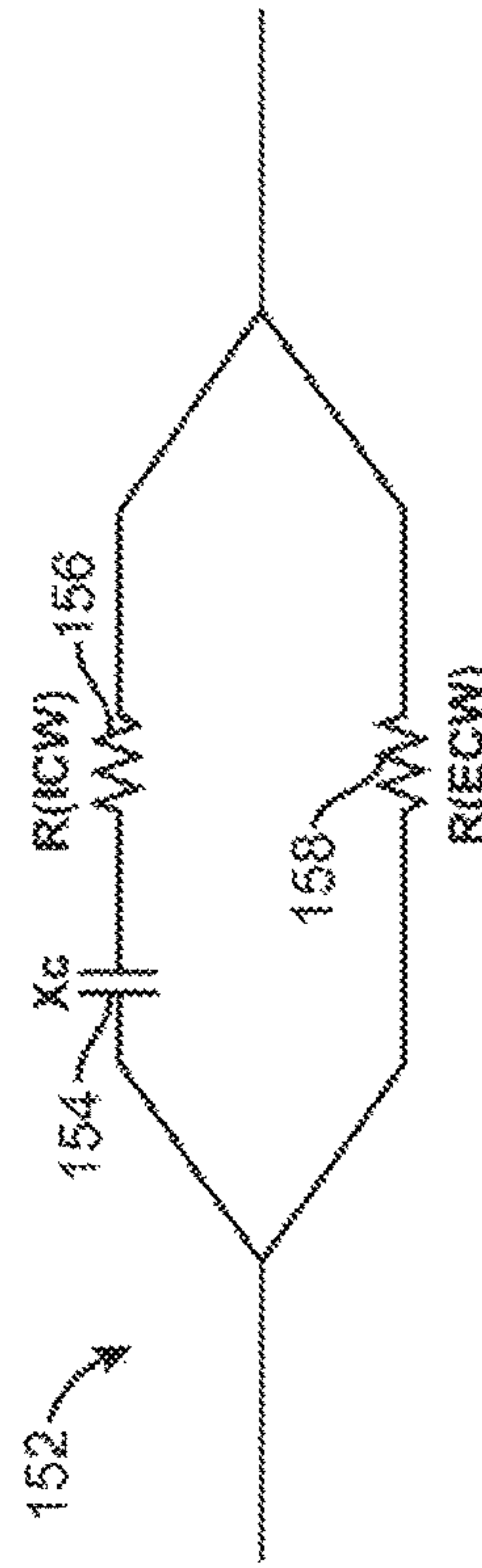

FIG. 1D1

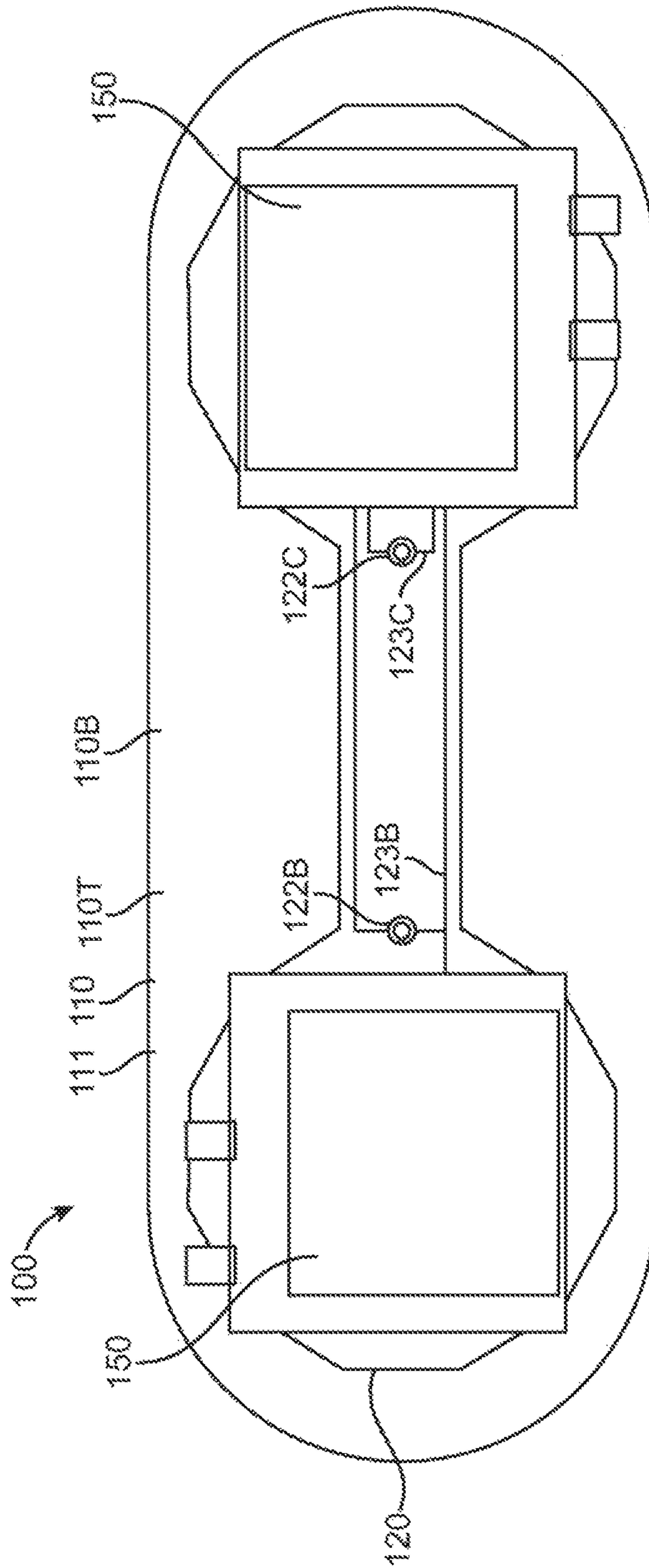

FIG. 1E

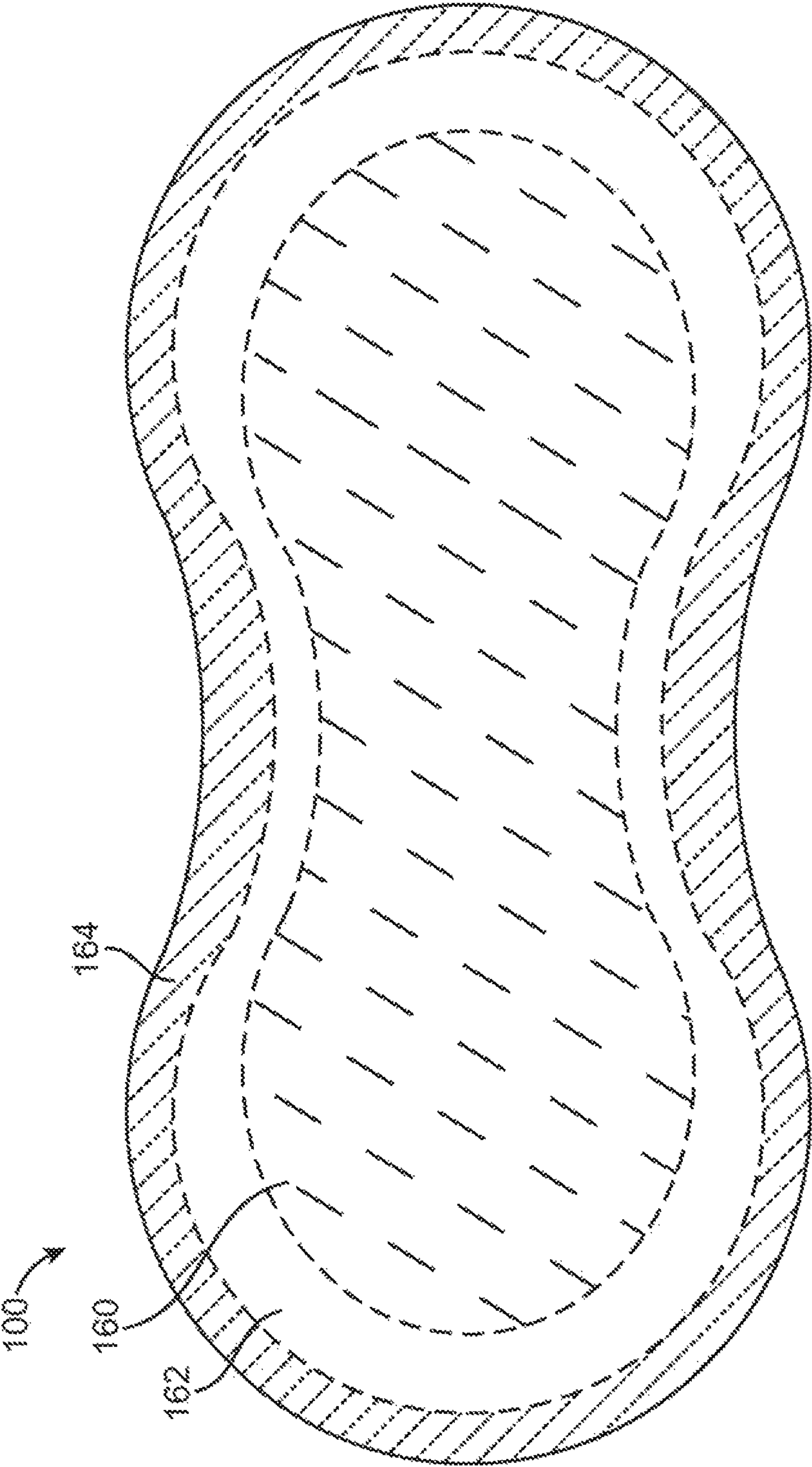

FIG. 1F

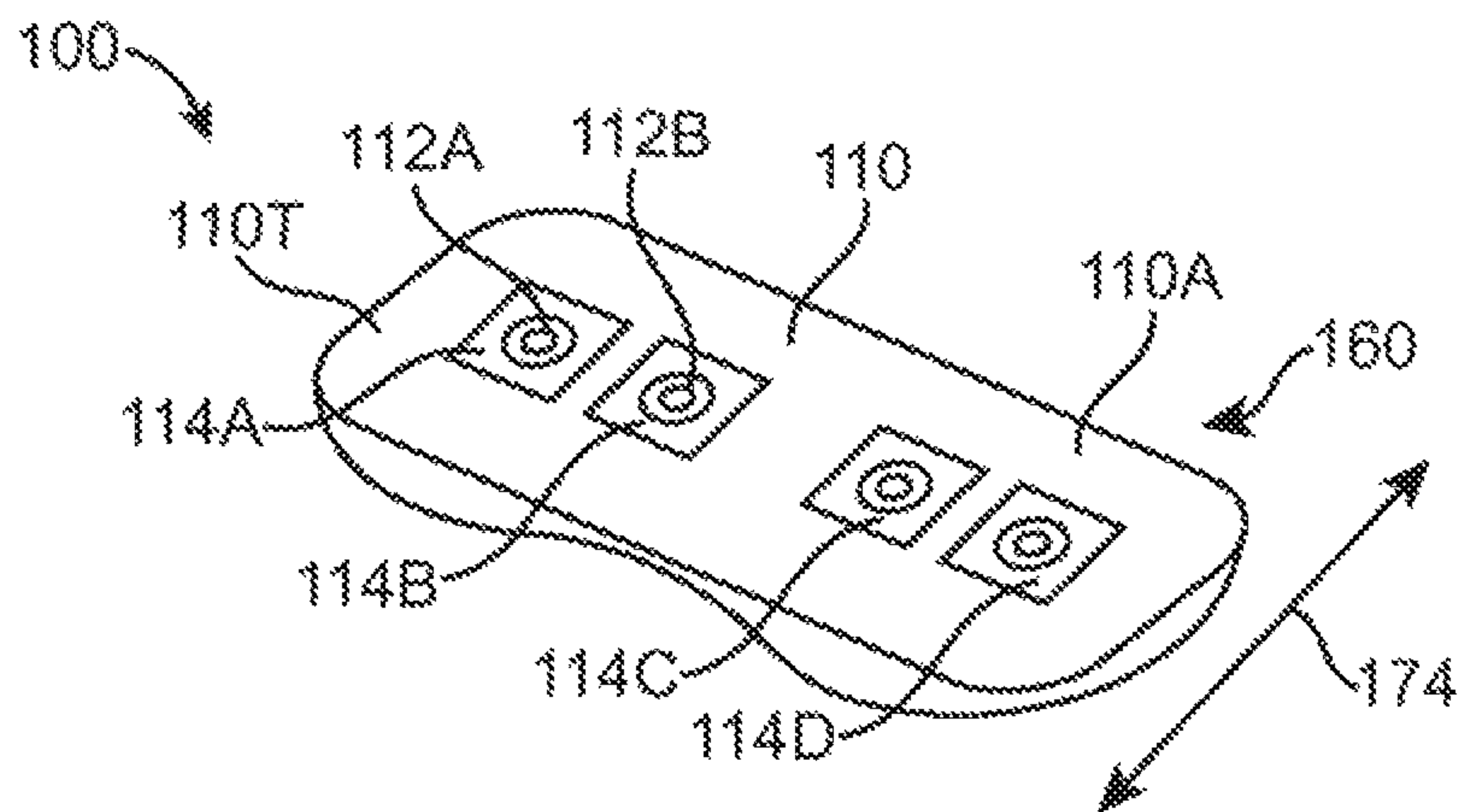

FIG. 1H

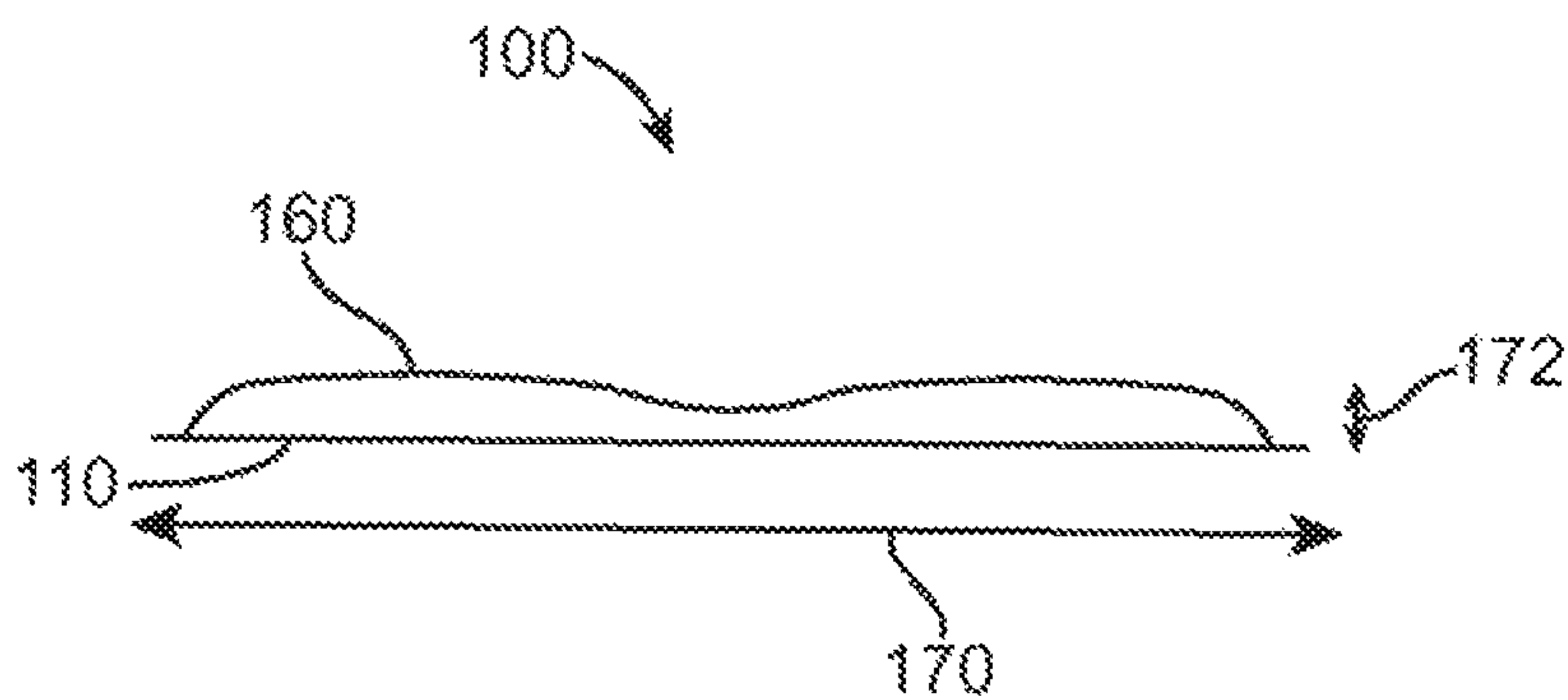

FIG. 1G

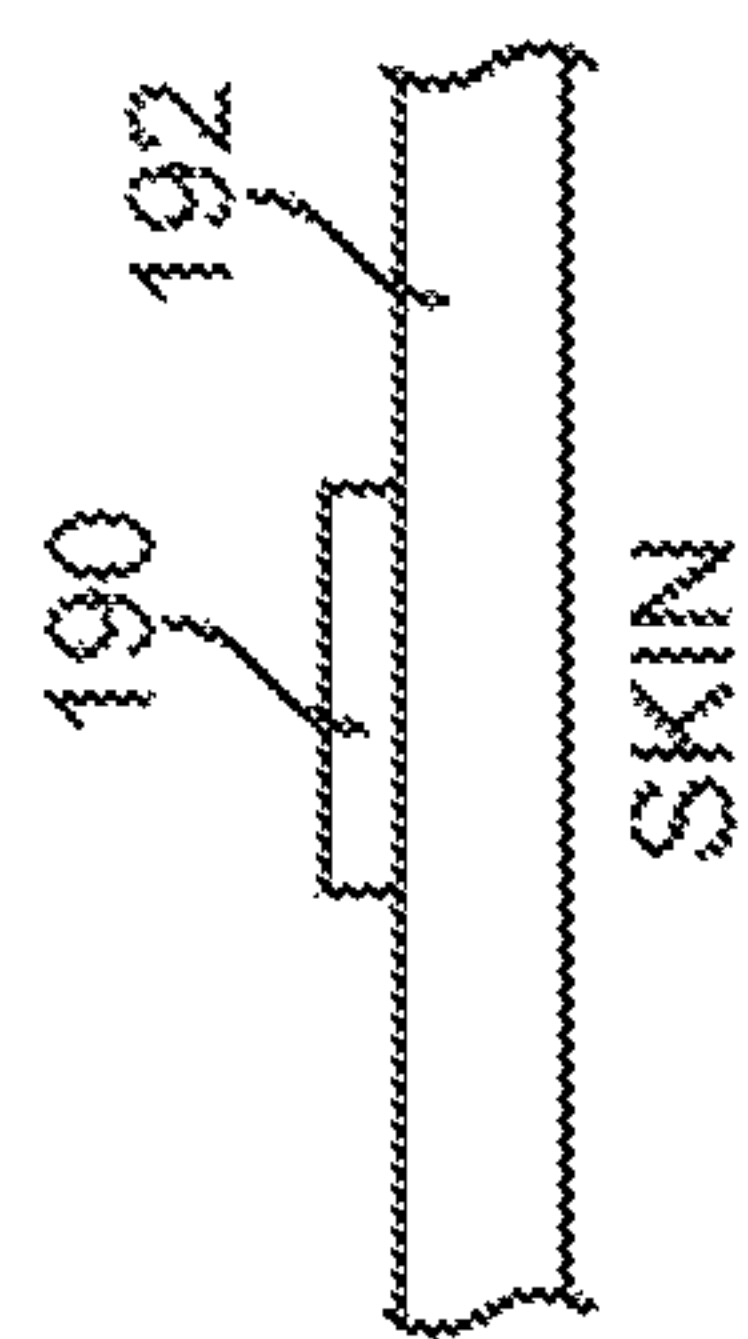

FIG. 1K

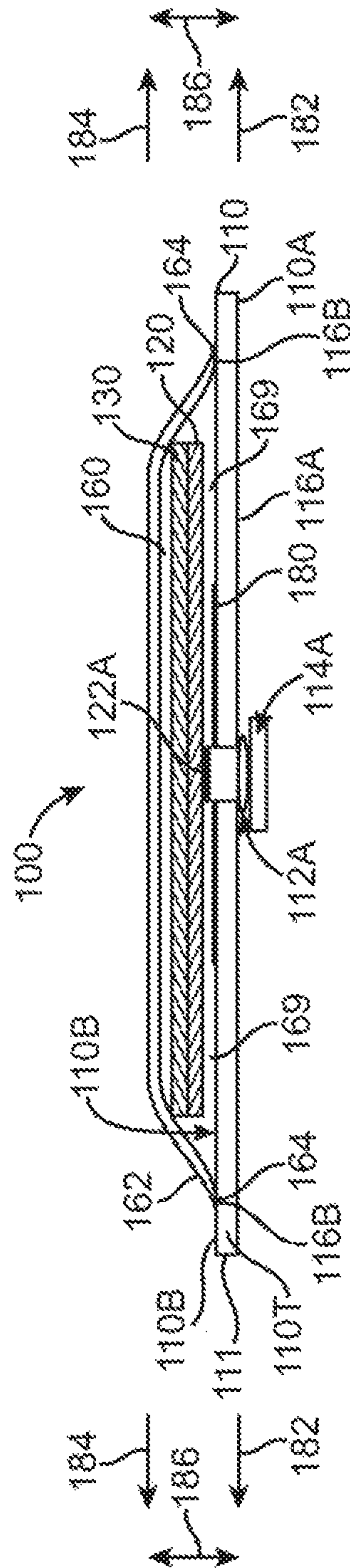

FIG. 1I

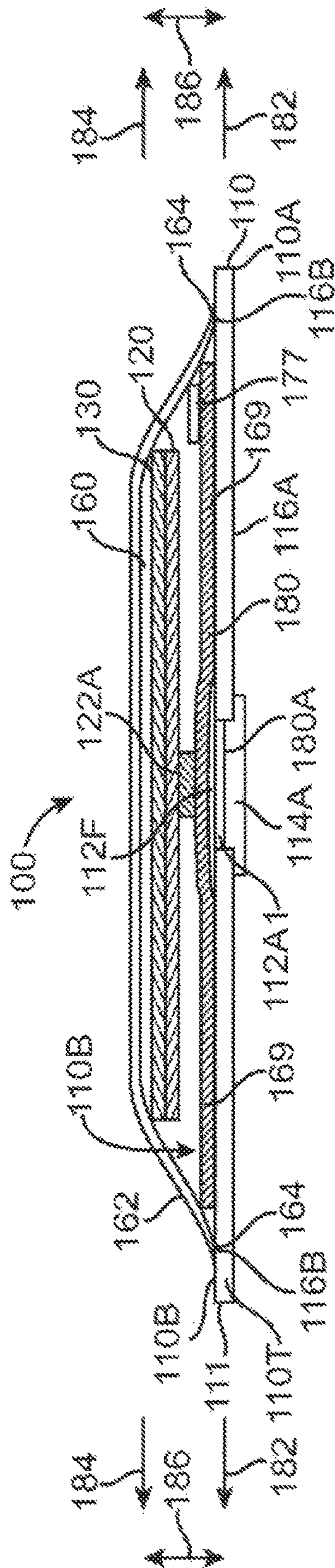

FIG. 111

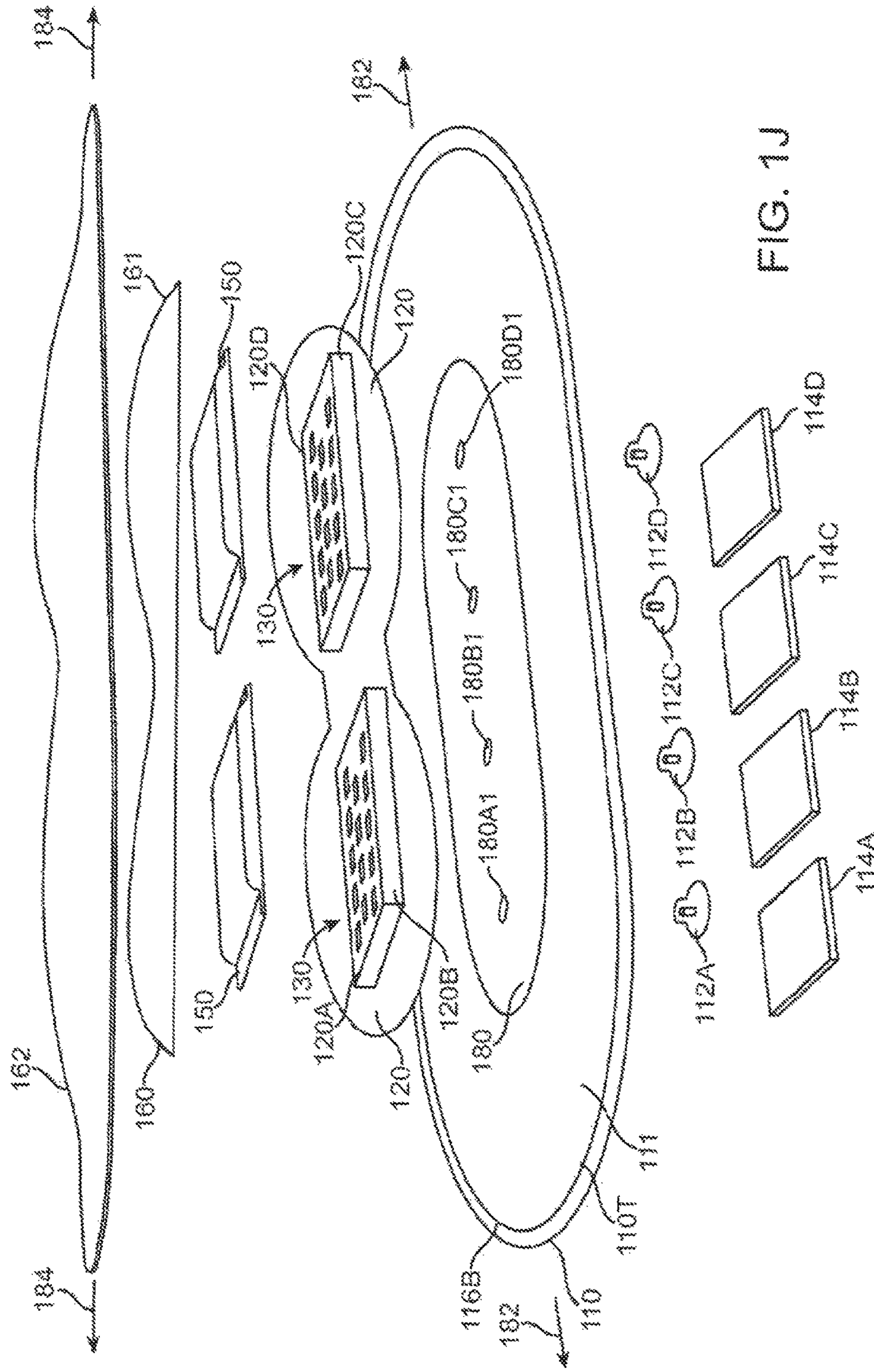

FIG. 1J

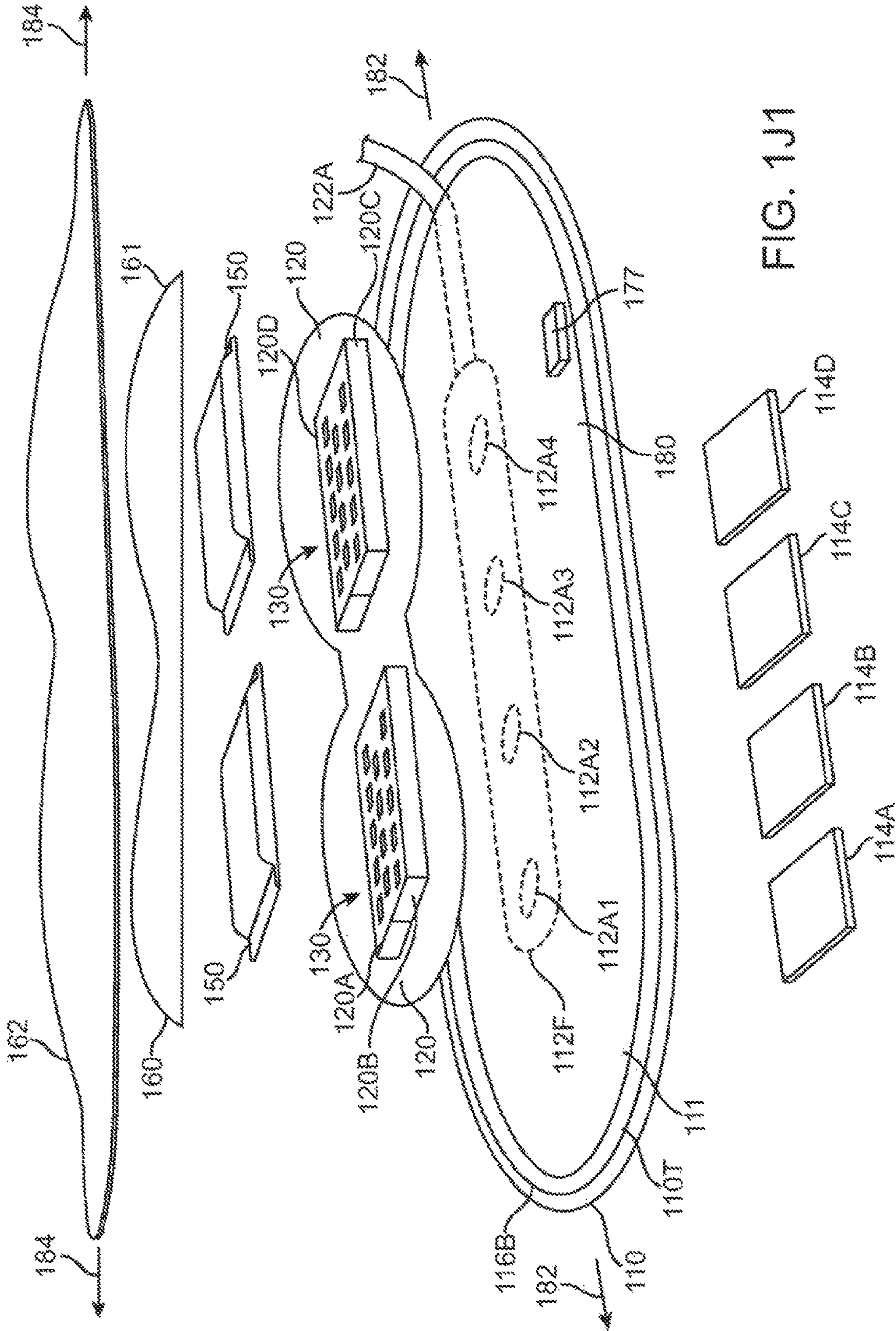

FIG. 1J1

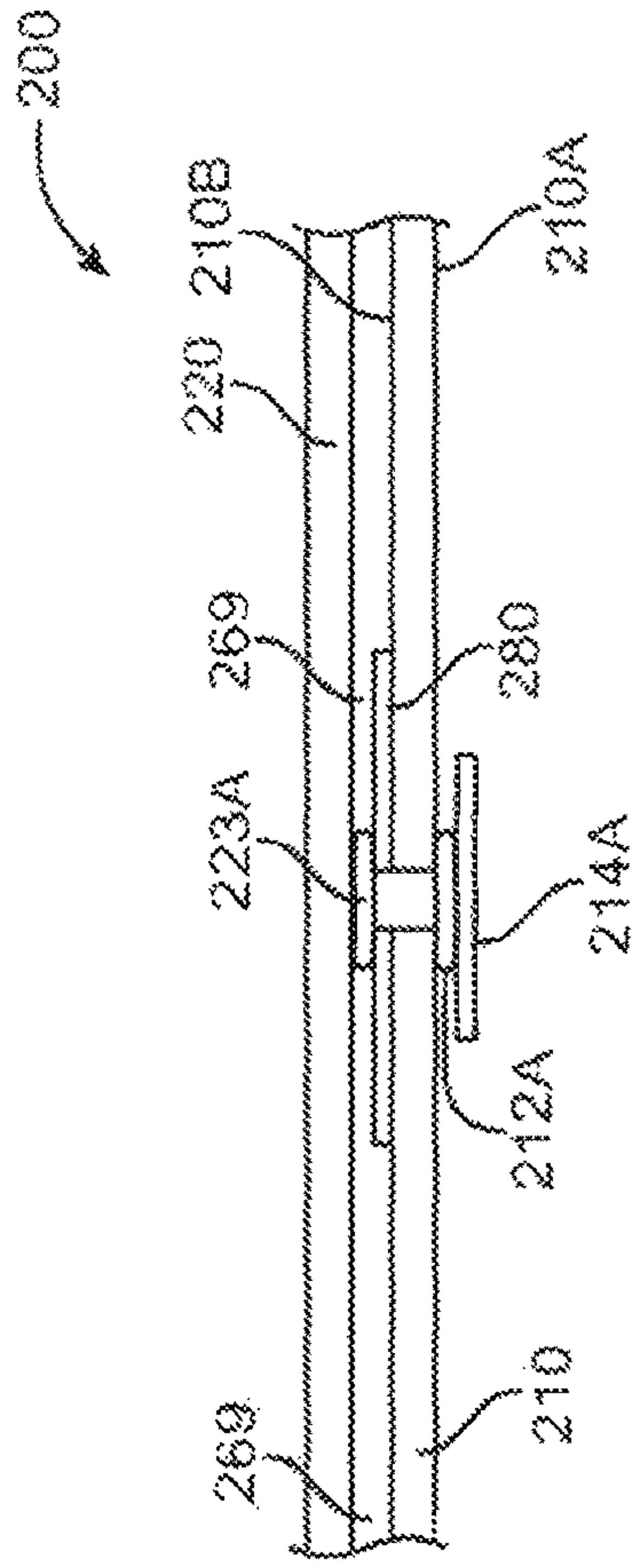

FIG. 2B

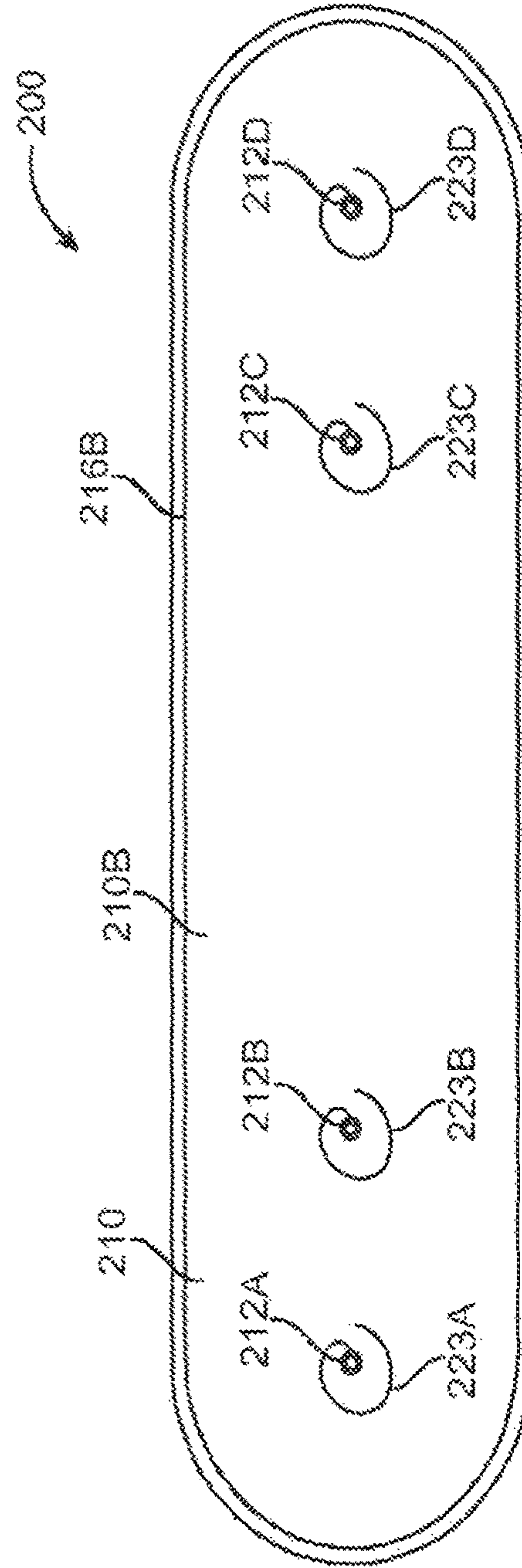

FIG. 2A

**ADHERENT DEVICE WITH MULTIPLE
PHYSIOLOGICAL SENSORS**

Matter enclosed in heavy brackets [] appears in the original patent but forms no part of this reissue specification; matter printed in italics indicates the additions made by reissue; a claim printed with strikethrough indicates that the claim was canceled, disclaimed, or held invalid by a prior post-patent action or proceeding.

CROSS-REFERENCES TO RELATED
APPLICATIONS

The present application is a continuation of pending U.S. patent application Ser. No. 13/347,238 filed Jan. 10, 2012 and titled "Adherent Device with Multiple Physiological Sensors" which is a continuation of U.S. patent application Ser. No. 12/209,273 filed Sep. 12, 2008 and titled "Adherent Device with Multiple Physiological Sensors", now U.S. Pat. No. 8,116,841, which claims the benefit under 35 USC 119(e) of U.S. Provisional Application Nos. 60/972,629 and 60/972,537 both filed Sep. 14, 2007, and 61/055,645 and 61/055,666 both filed May 23, 2008; the full disclosures of all of which are incorporated herein by reference in their entirety.

The subject matter of the present application is related to the following applications: 60/972,512; 60/972,329; 60/972,354; 60/972,616; 60/972,363; 60/972,343; 60/972,581; 60/972,316; 60/972,333; 60/972,359; 60/972,336; 60/972,340 all of which were filed on Sep. 14, 2007; 61/046,196 filed Apr. 18, 2008; 61/047,875 filed Apr. 25, 2008; 61/055,656 and 61/055,662 both filed May 23, 2008; and 61/079,746 filed Jul. 10, 2008.

The following applications were filed concurrently with the parent of the present application, on Sep. 12, 2008: U.S. application Ser. No. 12/209,279 entitled "Multi-Sensor Patient Monitor to Detect Impending Cardiac Decompensation Prediction"; 026843-000220US entitled "Adherent Device with Multiple Physiological Sensors"; 026843-000410US entitled "Injectable Device for Physiological Monitoring"; 026843-000510US entitled "Delivery System for Injectable Physiological Monitoring System"; 026843-000620US entitled "Adherent Device for Cardiac Rhythm Management"; 026843-000710US entitled "Adherent Device for Respiratory Monitoring"; 026843-000810US entitled "Adherent Athletic Monitor"; 026843-000910US entitled "Adherent Emergency Monitor"; 026843-001410US entitled "Medical Device Automatic Start-up upon Contact to Patient Tissue"; 026843-001900US entitled "System and Methods for Wireless Body Fluid Monitoring"; 026843-002010US entitled "Adherent Cardiac Monitor with Advanced Sensing Capabilities"; 026843-002410US entitled "Adherent Device for Sleep Disordered Breathing"; 026843-002710US entitled "Dynamic Pairing of Patients to Data Collection Gateways"; 026843-003010US entitled "Adherent Multi-Sensor Device with Implantable Device Communications Capabilities"; 026843-003110US entitled "Data Collection in a Multi-Sensor Patient Monitor"; 026843-003210US entitled "Adherent Multi-Sensor Device with Empathic Monitoring"; 026843-003310US entitled

"Energy Management for Adherent Patient Monitor"; and 026843-003410US entitled "Tracking and Security for Adherent Patient Monitor."

BACKGROUND OF THE INVENTION

1. Field of the Invention

The present invention relates to patient monitoring and/or therapy. Although embodiments make specific reference to monitoring impedance and electrocardiogram signals with an adherent device, the system methods and devices described herein may be applicable to many applications in which physiological monitoring and/or therapy is used for extended periods, for example wireless physiological monitoring for extended periods.

Patients are often treated for diseases and/or conditions associated with a compromised status of the patient, for example a compromised physiologic status. In some instances, a patient may report symptoms that require diagnosis to determine the underlying cause. For example, a patient may report fainting or dizziness that requires diagnosis, in which long term monitoring of the patient can provide useful information as to the physiologic status of the patient. In some instances a patient may have suffered a heart attack and require care and/or monitoring after release from the hospital. One example of a device to provide long term monitoring of a patient is the Holter monitor, or ambulatory electrocardiography device.

In addition to measuring heart signals with electrocardiograms, known physiologic measurements include impedance measurements. For example, transthoracic impedance measurements can be used to measure hydration and respiration. Although transthoracic measurements can be useful, such measurements may use electrodes that are positioned across the midline of the patient, and may be somewhat uncomfortable and/or cumbersome for the patient to wear. In at least some instances, the electrodes that are held against the skin of the patient may become detached and/or dehydrated, such that the electrodes must be replaced, thereby making long term monitoring more difficult.

Work in relation to embodiments of the present invention suggests that known methods and apparatus for long term monitoring of patients may be less than ideal. In at least some instances, devices that are worn by the patient may be somewhat uncomfortable, which may lead to patients not wearing the devices and not complying with direction from the health care provider, such that data collected may be less than ideal.

Therefore, a need exists for improved patient monitoring. Ideally, such improved patient monitoring would avoid at least some of the short-comings of the present methods and devices.

2. Description of the Background Art

The following U.S. Patents and Publications may describe relevant background art: U.S. Pat. Nos. 3,170,459; 3,370,459; 3,805,769; 3,845,757; 3,972,329; 4,121,573; 4,141,366; 4,838,273; 4,955,381; 4,981,139; 5,080,099; 5,353,793; 5,511,553; 5,544,661; 5,558,638; 5,724,025; 5,772,586; 5,862,802; 6,047,203; 6,117,077; 6,129,744; 6,225,901; 6,385,473; 6,416,471; 6,454,707; 6,527,711; 6,527,729; 6,551,252; 6,595,927; 6,595,929; 6,605,038; 6,645,153; 6,795,722; 6,821,249; 6,980,851; 7,020,508; 7,054,679; 7,153,262; 2003/0092975; 2005/0113703; 2005/0131288; 2006/0010090; 2006/0031102; 2006/0089679;

2006/122474; 2006/0155183; 2006/0224051; 2006/0264730; 2007/0021678; and 2007/0038038.

BRIEF SUMMARY OF THE INVENTION

The present invention relates to patient monitoring. Although embodiments make specific reference to monitoring impedance and electrocardiogram signals with an adherent patch, the system methods and device described herein may be applicable to any application in which physiological monitoring and/or therapy is used for extended periods, for example wireless physiological monitoring for extended periods. In many embodiments, the adherent device comprises a breathable support, for example a breathable adherent patch, and breathable cover that can be used for extended periods with improved patient comfort. The breathable adherent patch, for example breathable tape, and breathable cover may be configured to stretch, for example to stretch together along two dimensions of the skin of the patient when the patch is adhered to the skin of the patient, such that patient comfort and the lifetime of the patch on the skin can be improved.

According to one aspect, an adherent device to monitor a patient for an extended period includes a breathable tape with an adhesive coating to adhere the breathable tape to a skin of the patient, at least one electrode affixed to the breathable tape and capable of electrically coupling to a skin of the patient, and electronic components electrically coupled to the at least one electrode to measure physiologic signals of the patient. The electronic components are coupled to the breathable tape to support the electronic components when the tape is adhered to the patient. The adherent device further includes an electronics housing covering the electronic components, and a breathable cover disposed over the electronic components such that the electronics housing is disposed between the cover and the electronic components. In some embodiments, the adherent device further includes a printed circuit board to which the electronic components are electrically connected. The adherent device may further include a flexible connection structure to couple the electrodes to the printed circuit board so as to relieve strain between the electrodes and the printed circuit board. The electronics housing may be adhered to at least one of the electronic components. The breathable cover may be connected to the breathable tape. The breathable cover may include a stretchable material. In some embodiments, the breathable cover fits loosely over the electronics housing, such that a portion of the breathable cover can move with respect to the electronics housing. The electronics housing may be smooth, such that the breathable cover is slidably coupled with the electronics housing.

In some embodiments, the electronic components comprise wireless communications circuitry that transmits at least one physiologic signal to a remote server. The electronic components may include impedance circuitry, wherein the wireless communications circuitry is coupled to the impedance circuitry to transmit to the remote server a hydration signal derived from an output of the impedance circuitry. The electronic components may include electrocardiogram circuitry, wherein the wireless communications circuitry is coupled to the electrocardiogram circuitry to transmit to the remote server an electrocardiogram signal derived from an output of the electrocardiogram circuitry. The electronic components may include an accelerometer, wherein the wireless communications circuitry is coupled to the accelerometer to transmit to the remote server an inclination signal derived from an output of the accelerometer.

In some embodiments, the breathable tape comprises an acrylate pressure sensitive adhesive on an underside of the tape, and the adhesive has a thickness less than about 0.004" to allow the tape to breath when the adhesive is applied to the patient. In some embodiments, the electronics housing comprises a waterproof encapsulant to protect the electronic components from moisture and/or mechanical forces.

In some embodiments, the adherent device includes a gel cover positioned over the breathable tape to inhibit a flow of the gel through the breathable tape, and the electronic components are located over the gel cover such that the gel cover is disposed between the breathable tape and the electronic components. The gel cover may include at least one of a polyurethane film or polyurethane non-woven backing and an acrylate pressure sensitive adhesive. The gel cover may have a porosity of at least about 200 sec./100 cc/in² to protect the hydrogel from external moisture. The breathable tape may include a knit polyester fabric backing and the gel cover may include a polyurethane film backing.

In some embodiments, the breathable tape has a first porosity and the gel cover comprises a breathable tape with a second porosity, the second porosity less than the first porosity to inhibit flow of the gel through the breathable tape having the first porosity.

In some embodiments, the electronic components are comprised in an electronics module that is separable from the breathable tape, the adhesive coating, and the at least one electrode. The electronics module may be reusable. The breathable tape, the adhesive coating, and the at least one electrode may not be reusable. The electronics module may include the breathable cover. The electronics module may include the electronics housing.

In some embodiments, the adherent device further includes at least one gel disposed over a contact surface of the at least one electrode to electrically connect the electrode to the skin. The adherent device may further include an adhesive disposed around the breathable tape to connect the cover to the breathable tape. The adherent device may further include a gel cover positioned over the breathable tape, wherein a moisture vapor transmission rate (MVTR) through the breathable tape, the gel cover, and the breathable cover is at least about 400 g/m²/24 hrs.

BRIEF DESCRIPTION OF THE DRAWINGS

FIG. 1A shows a patient and a monitoring system comprising an adherent device, according to embodiments of the present invention;

FIG. 1B shows a bottom view of the adherent device as in FIG. 1A comprising an adherent patch;

FIG. 1C shows a top view of the adherent patch, as in FIG. 1B;

FIG. 1D shows a printed circuit boards and electronic components over the adherent patch, as in FIG. 1C;

FIG. 1D1 shows an equivalent circuit that can be used to determine optimal frequencies for determining patient hydration, according to embodiments of the present invention;

FIG. 1E shows batteries positioned over the printed circuit board and electronic components as in FIG. 1D;

FIG. 1F shows a top view of an electronics housing and a breathable cover over the batteries, electronic components and printed circuit board as in FIG. 1E;

FIG. 1G shows a side view of the adherent device as in FIGS. 1A to 1F;

FIG. 1H shown a bottom isometric view of the adherent device as in FIGS. 1A to 1G;

5

FIGS. 1I and 1J show a side cross-sectional view and an exploded view, respectively, of the adherent device as in FIGS. 1A to 1H;

FIGS. 1I1 and 1J1 show a side cross-sectional view and an exploded view, respectively, of an adherent device with a temperature sensor affixed to the gel cover, according to embodiments of the present invention;

FIG. 1K shows at least one electrode configured to electrically couple to a skin of the patient through a breathable tape, according to embodiments of the present invention; and

FIGS. 2A and 2B show components of an adherent device comprising an adhesive patch and connection structures to provide strain relief so as to decouple the adhesive patch from an electronics module, according to embodiments of the present invention.

DETAILED DESCRIPTION OF THE INVENTION

Embodiments of the present invention relate to patient monitoring and/or therapy. Although embodiments make specific reference to monitoring impedance and electrocardiogram signals with an adherent device, the system methods and device described herein may be applicable to any application in which physiological monitoring and/or therapy is used for extended periods, for example wireless physiological monitoring for extended periods.

The adherent device comprises a support, for example a patch that may comprise breathable tape, and the support can be configured to adhere to the patient and support the electronics and sensors on the patient. The support can be porous and breathable so as to allow water vapor transmission. The support can also stretch with skin of the patient, so as to improve patient comfort and extend the time that the support can be adhered to the patient.

In many embodiments, the adherent devices described herein may be used for 90 day monitoring, or more, and may comprise completely disposable components and/or reusable components, and can provide reliable data acquisition and transfer. In many embodiments, the patch is configured for patient comfort, such that the patch can be worn and/or tolerated by the patient for extended periods, for example 90 days or more. The patch may be worn continuously for at least seven days, for example 14 days, and then replaced with another patch. Adherent devices with comfortable patches that can be worn for extended periods and in which patches can be replaced and the electronics modules reused are described in U.S. Pat. App. Nos. 60/972,537, entitled "Adherent Device with Multiple Physiological Sensors"; and 60/972,629, entitled "Adherent Device with Multiple Physiological Sensors", both filed on Sep. 14, 2007, the full disclosures of which have been previously incorporated herein by reference. In many embodiments, the adherent patch comprises a tape, which comprises a material, preferably breathable, with an adhesive, such that trauma to the patient skin can be minimized while the patch is worn for the extended period. The printed circuit board may comprise a flex printed circuit board that can flex with the patient to provide improved patient comfort.

FIG. 1A shows a patient P and a monitoring system 10. Patient P comprises a midline M, a first side S1, for example a right side, and a second side S2, for example a left side. Monitoring system 10 comprises an adherent device 100. Adherent device 100 can be adhered to a patient P at many locations, for example thorax T of patient P. In many embodiments, the adherent device may adhere to one side of

6

the patient, from which side data can be collected. Work in relation with embodiments of the present invention suggests that location on a side of the patient can provide comfort for the patient while the device is adhered to the patient.

Monitoring system 10 includes components to transmit data to a remote center 106. Remote center 106 can be located in a different building from the patient, for example in the same town as the patient, and can be located as far from the patient as a separate continent from the patient, for example the patient located on a first continent and the remote center located on a second continent. Adherent device 100 can communicate wirelessly to an intermediate device 102, for example with a single wireless hop from the adherent device on the patient to the intermediate device. Intermediate device 102 can communicate with remote center 106 in many ways, for example with an internet connection and/or with a cellular connection. In many embodiments, monitoring system 10 comprises a distributed processing system with at least one processor comprising a tangible medium on device 100, at least one processor on intermediate device 102, and at least one processor 106P at remote center 106, each of which processors can be in electronic communication with the other processors. At least one processor 102P comprises a tangible medium 102T, and at least one processor 106P comprises a tangible medium 106T. Remote processor 106P may comprise a backend server located at the remote center. Remote center 106 can be in communication with a health care provider 108A with a communication system 107A, such as the Internet, an intranet, phone lines, wireless and/or satellite phone. Health care provider 108A, for example a family member, can be in communication with patient P with a communication, for example with a two way communication system, as indicated by arrow 109A, for example by cell phone, email, landline. Remote center 106 can be in communication with a health care professional, for example a physician 108B, with a communication system 107B, such as the Internet, an intranet, phone lines, wireless and/or satellite phone. Physician 108B can be in communication with patient P with a communication, for example with a two way communication system, as indicated by arrow 109B, for example by cell phone, email, landline. Remote center 106 can be in communication with an emergency responder 108C, for example a 911 operator and/or paramedic, with a communication system 107C, such as the Internet, an intranet, phone lines, wireless and/or satellite phone. Emergency responder 108C can travel to the patient as indicated by arrow 109C. Thus, in many embodiments, monitoring system 10 comprises a closed loop system in which patient care can be monitored and implemented from the remote center in response to signals from the adherent device.

In many embodiments, the adherent device may continuously monitor physiological parameters, communicate wirelessly with a remote center, and provide alerts when necessary. The system may comprise an adherent patch, which attaches to the patient's thorax and contains sensing electrodes, battery, memory, logic, and wireless communication capabilities. In some embodiments, the patch can communicate with the remote center, via the intermediate device in the patient's home. In some embodiments, the remote center 106 receives the patient data and applies a patient evaluation and/or prediction algorithm. When a flag is raised, the center may communicate with the patient, hospital, nurse, and/or physician to allow for therapeutic intervention, for example to prevent decompensation.

The adherent device may be affixed and/or adhered to the body in many ways. For example, with at least one of the

following an adhesive tape, a constant-force spring, suspenders around shoulders, a screw-in microneedle electrode, a pre-shaped electronics module to shape fabric to a thorax, a pinch onto roll of skin, or transcutaneous anchoring. Patch and/or device replacement may occur with a keyed patch (e.g. two-part patch), an outline or anatomical mark, a low-adhesive guide (place guide|remove old patch|place new patch|remove guide), or a keyed attachment for chatter reduction. The patch and/or device may comprise an adhesiveless embodiment (e.g. chest strap), and/or a low-irritation adhesive for sensitive skin. The adherent patch and/or device can comprise many shapes, for example at least one of a dogbone, an hourglass, an oblong, a circular or an oval shape.

In many embodiments, the adherent device may comprise a reusable electronics module with replaceable patches, and each of the replaceable patches may include a battery. The module may collect cumulative data for approximately 90 days and/or the entire adherent component (electronics+patch) may be disposable. In a completely disposable embodiment, a “baton” mechanism may be used for data transfer and retention, for example baton transfer may include baseline information. In some embodiments, the device may have a rechargeable module, and may use dual battery and/or electronics modules, wherein one module **101A** can be recharged using a charging station **103** while the other module **101B** is placed on the adherent patch with connectors. In some embodiments, the intermediate device **102** may comprise the charging module, data transfer, storage and/or transmission, such that one of the electronics modules can be placed in the intermediate device for charging and/or data transfer while the other electronics module is worn by the patient.

System **10** can perform the following functions: initiation, programming, measuring, storing, analyzing, communicating, predicting, and displaying. The adherent device may contain a subset of the following physiological sensors: bioimpedance, respiration, respiration rate variability, heart rate (ave, min, max), heart rhythm, heart rate variability (hereinafter “HRV”), heart rate turbulence (hereinafter “HRT”), heart sounds (e.g. S3), respiratory sounds, blood pressure, activity, posture, wake/sleep, orthopnea, temperature/heat flux, and weight. The activity sensor may comprise one or more of the following: ball switch, accelerometer, minute ventilation, HR, bioimpedance noise, skin temperature/heat flux, BP, muscle noise, posture.

The adherent device can wirelessly communicate with remote center **106**. The communication may occur directly (via a cellular or Wi-Fi network), or indirectly through intermediate device **102**. Intermediate device **102** may consist of multiple devices, which can communicate wired or wirelessly to relay data to remote center **106**.

In many embodiments, instructions are transmitted from remote site **106** to a processor supported with the adherent patch on the patient, and the processor supported with the patient can receive updated instructions for the patient treatment and/or monitoring, for example while worn by the patient.

FIG. **1B** shows a bottom view of adherent device **100** as in FIG. **1A** comprising an adherent patch **110**. Adherent patch **110** comprises a first side, or a lower side **110A**, that is oriented toward the skin of the patient when placed on the patient. In many embodiments, adherent patch **110** comprises a tape **110T** which is a material, preferably breathable, with an adhesive **116A**. Patient side **110A** comprises adhesive **116A** to adhere the patch **110** and adherent device **100** to patient P. Electrodes **112A**, **112B**, **112C** and **112D** are

affixed to adherent patch **110**. In many embodiments, at least four electrodes are attached to the patch, for example six electrodes. In some embodiments the patch comprises two electrodes, for example two electrodes to measure the electrocardiogram (ECG) of the patient. Gel **114A**, gel **114B**, gel **114C** and gel **114D** can each be positioned over electrodes **112A**, **112B**, **112C** and **112D**, respectively, to provide electrical conductivity between the electrodes and the skin of the patient. In many embodiments, the electrodes can be affixed to the patch **110**, for example with known methods and structures such as rivets, adhesive, stitches, etc. In many embodiments, patch **110** comprises a breathable material to permit air and/or vapor to flow to and from the surface of the skin.

FIG. **1C** shows a top view of the adherent patch **100**, as in FIG. **1B**. Adherent patch **100** comprises a second side, or upper side **110B**. In many embodiments, electrodes **112A**, **112B**, **112C** and **112D** extend from lower side **110A** through adherent patch **110** to upper side **110B**. An adhesive **116B** can be applied to upper side **110B** to adhere structures, for example a breathable cover, to the patch such that the patch can support the electronics and other structures when the patch is adhered to the patient. The printed circuit board (hereinafter “PCB”) may comprise completely flex PCB, combined flex PCB and/or rigid PCB boards connected by cable.

FIG. **1D** shows a printed circuit boards and electronic components over adherent patch **110**, as in FIGS. **1A** to **1C**. In some embodiments, a printed circuit board (PCB), for example flex printed circuit board **120**, may be connected to electrodes **112A**, **112B**, **112C** and **112D** with connectors **122A**, **122B**, **122C** and **122D**. Flex printed circuit board **120** can include traces **123A**, **123B**, **123C** and **123D** that extend to connectors **122A**, **122B**, **122C** and **122D**, respectively, on the flex printed circuit board. Connectors **122A**, **122B**, **122C** and **122D** can be positioned on flex printed circuit board **120** in alignment with electrodes **112A**, **112B**, **112C** and **112D** so as to electrically couple the flex PCB with the electrodes. In some embodiments, connectors **122A**, **122B**, **122C** and **122D** may comprise insulated wires and/or a film with conductive ink that provide strain relief between the PCB and the electrodes. For example, connectors **122A**, **122B**, **122C** and **122D** may comprise a flexible film, such as at least one of known polyester film or known polyurethane film, coated with a conductive ink, for example a conductive silver ink. In some embodiments, additional PCB’s, for example rigid PCB’s **120A**, **120B**, **120C** and **120D**, can be connected to flex PCB **120**. Electronic components **130** can be connected to flex PCB **120** and/or mounted thereon. In some embodiments, electronic components **130** can be mounted on the additional PCB’s.

Electronic components **130** comprise components to take physiologic measurements, transmit data to remote center **106** and receive commands from remote center **106**. In many embodiments, electronics components **130** may comprise known low power circuitry, for example complementary metal oxide semiconductor (CMOS) circuitry components. Electronics components **130** comprise an activity sensor and activity circuitry **134**, impedance circuitry **136** and electrocardiogram circuitry, for example ECG circuitry **138**. In some embodiments, electronics circuitry **130** may comprise a microphone and microphone circuitry **142** to detect an audio signal from within the patient, and the audio signal may comprise a heart sound and/or a respiratory sound, for example an S3 heart sound and a respiratory sound with rales and/or crackles.

Electronics circuitry **130** may comprise a temperature sensor **177**, for example a thermistor in contact with the skin of the patient, and temperature sensor circuitry **144** to measure a temperature of the patient, for example a temperature of the skin of the patient. A temperature sensor **177** may be used to determine the sleep and wake state of the patient. The temperature of the patient can decrease as the patient goes to sleep and increase when the patient wakes up.

Work in relation to embodiments of the present invention suggests that skin temperature may effect impedance and/or hydration measurements, and that skin temperature measurements may be used to correct impedance and/or hydration measurements. In some embodiments, increase in skin temperature or heat flux can be associated with increased vasodilation near the skin surface, such that measured impedance measurement decreased, even through the hydration of the patient in deeper tissues under the skin remains substantially unchanged. Thus, use of the temperature sensor can allow for correction of the hydration signals to more accurately assess the hydration, for example extra cellular hydration, of deeper tissues of the patient, for example deeper tissues in the thorax.

Electronics circuitry **130** may comprise a processor **146**. Processor **146** comprises a tangible medium, for example read only memory (ROM), electrically erasable programmable read only memory (EEPROM) and/or random access memory (RAM). Electronic circuitry **130** may comprise real time clock and frequency generator circuitry **148**. In some embodiments, processor **136** may comprise the frequency generator and real time clock. The processor can be configured to control a collection and transmission of data from the impedance circuitry electrocardiogram circuitry and the accelerometer. In many embodiments, device **100** comprise a distributed processor system, for example with multiple processors on device **100**.

In many embodiments, electronics components **130** comprise wireless communications circuitry **132** to communicate with remote center **106**. Printed circuit board **120** may comprise an antenna to facilitate wireless communication. The antennae may be integral with printed circuit board **120** or may be separately coupled thereto. The wireless communication circuitry can be coupled to the impedance circuitry, the electrocardiogram circuitry and the accelerometer to transmit to a remote center with a communication protocol at least one of the hydration signal, the electrocardiogram signal or the inclination signal. In specific embodiments, wireless communication circuitry is configured to transmit the hydration signal, the electrocardiogram signal and the inclination signal to the remote center with a single wireless hop, for example from wireless communication circuitry **132** to intermediate device **102**. The communication protocol comprises at least one of Bluetooth, Zigbee, WiFi, WiMax, IR, amplitude modulation or frequency modulation. In many embodiments, the communications protocol comprises a two way protocol such that the remote center is capable of issuing commands to control data collection.

Intermediate device **102** may comprise a data collection system to collect and store data from the wireless transmitter. The data collection system can be configured to communicate periodically with the remote center. The data collection system can transmit data in response to commands from remote center **106** and/or in response to commands from the adherent device.

Activity sensor and activity circuitry **134** can comprise many known activity sensors and circuitry. In many embodiments, the accelerometer comprises at least one of a piezoelectric accelerometer, capacitive accelerometer or electro-

mechanical accelerometer. The accelerometer may comprises a 3-axis accelerometer to measure at least one of an inclination, a position, an orientation or acceleration of the patient in three dimensions. Work in relation to embodiments of the present invention suggests that three dimensional orientation of the patient and associated positions, for example sitting, standing, lying down, can be very useful when combined with data from other sensors, for example ECG data and/or hydration data.

Impedance circuitry **136** can generate both hydration data and respiration data. In many embodiments, impedance circuitry **136** is electrically connected to electrodes **112A**, **112B**, **112C** and **112D** such that electrodes **112A** and **112D** comprise outer electrodes that are driven with a current, or force electrodes. The current delivered between electrodes **112A** and **112D** generates a measurable voltage between electrodes **112B** and **112C**, such that electrodes **112B** and **112C** comprise inner sense electrodes that sense and/or measure the voltage in response to the current from the force electrodes. In some embodiments, electrodes **112B** and **112C** may comprise force electrodes and electrodes **112A** and **112B** may comprise sense electrodes. The voltage measured by the sense electrodes can be used measure the impedance of the patient to determine respiration rate and/or the hydration of the patient.

FIG. **1D1** shows an equivalent circuit **152** that can be used to determine optimal frequencies for measuring patient hydration. Work in relation to embodiments of the present invention indicates that the frequency of the current and/or voltage at the force electrodes can be selected so as to provide impedance signals related to the extracellular and/or intracellular hydration of the patient tissue. Equivalent circuit **152** comprises an intracellular resistance **156**, or $R(ICW)$ in series with a capacitor **154**, and an extracellular resistance **158**, or $R(ECW)$. Extracellular resistance **158** is in parallel with intracellular resistance **156** and capacitor **154** related to capacitance of cell membranes. In many embodiments, impedances can be measured and provide useful information over a wide range of frequencies, for example from about 0.5 kHz to about 200 KHz. Work in relation to embodiments of the present invention suggests that extracellular resistance **158** can be significantly related extracellular fluid and to cardiac decompensation, and that extracellular resistance **158** and extracellular fluid can be effectively measured with frequencies in a range from about 0.5 kHz to about 20 kHz, for example from about 1 kHz to about 10 kHz. In some embodiments, a single frequency can be used to determine the extracellular resistance and/or fluid. As sample frequencies increase from about 10 kHz to about 20 kHz, capacitance related to cell membranes decrease the impedance, such that the intracellular fluid contributes to the impedance and/or hydration measurements. Thus, many embodiments of the present invention employ measure hydration with frequencies from about 0.5 kHz to about 20 kHz to determine patient hydration.

In many embodiments, impedance circuitry **136** can be configured to determine respiration of the patient. In specific embodiments, the impedance circuitry can measure the hydration at 25 Hz intervals, for example at 25 Hz intervals using impedance measurements with a frequency from about 0.5 kHz to about 20 kHz.

ECG circuitry **138** can generate electrocardiogram signals and data from two or more of electrodes **112A**, **112B**, **112C** and **112D** in many ways. In some embodiments, ECG circuitry **138** is connected to inner electrodes **112B** and **112C**, which may comprise sense electrodes of the impedance circuitry as described above. In some embodiments,

ECG circuitry **138** can be connected to electrodes **112A** and **112D** so as to increase spacing of the electrodes. The inner electrodes may be positioned near the outer electrodes to increase the voltage of the ECG signal measured by ECG circuitry **138**. In many embodiments, the ECG circuitry may measure the ECG signal from electrodes **112A** and **112D** when current is not passed through electrodes **112A** and **112D**, for example with switches as described in U.S. App. No. 60/972,527, the full disclosure of which has been previously incorporated herein by reference.

FIG. 1E shows batteries **150** positioned over the flex printed circuit board and electronic components as in FIG. 1D. Batteries **150** may comprise rechargeable batteries that can be removed and/or recharged. In some embodiments, batteries **150** can be removed from the adherent patch and recharged and/or replaced.

FIG. 1F shows a top view of a cover **162** over the batteries, electronic components and flex printed circuit board as in FIGS. 1A to 1E. In many embodiments, an electronics housing **160** may be disposed under cover **162** to protect the electronic components, and in some embodiments electronics housing **160** may comprise an encapsulant over the electronic components and PCB. In some embodiments, cover **162** can be adhered to adherent patch **110** with an adhesive **164** on an underside of cover **162**. In many embodiments, electronics housing **160** may comprise a water proof material, for example a sealant adhesive such as epoxy or silicone coated over the electronics components and/or PCB. In some embodiments, electronics housing **160** may comprise metal and/or plastic. Metal or plastic may be potted with a material such as epoxy or silicone.

Cover **162** may comprise many known biocompatible cover, casing and/or housing materials, such as elastomers, for example silicone. The elastomer may be fenestrated to improve breathability. In some embodiments, cover **162** may comprise many known breathable materials, for example polyester, polyamide, nylon and/or elastane (Spandex™). The breathable fabric may be coated to make it water resistant, waterproof, and/or to aid in wicking moisture away from the patch.

FIG. 1G shows a side view of adherent device **100** as in FIGS. 1A to 1F. Adherent device **100** comprises a maximum dimension, for example a length **170** from about 4 to 10 inches (from about 100 mm to about 250 mm), for example from about 6 to 8 inches (from about 150 mm to about 200 mm). In some embodiments, length **170** may be no more than about 6 inches (no more than about 150 mm). Adherent device **100** comprises a thickness **172**. Thickness **172** may comprise a maximum thickness along a profile of the device. Thickness **172** can be from about 0.2 inches to about 0.6 inches (from about 5 mm to about 15 mm), from about 0.2 inches to about 0.4 inches (from about 5 mm to about 10 mm), for example about 0.3 inches (about 7.5 mm).

FIG. 1H shown a bottom isometric view of adherent device **100** as in FIGS. 1A to 1G. Adherent device **100** comprises a width **174**, for example a maximum width along a width profile of adherent device **100**. Width **174** can be from about 2 to about 4 inches (from about 50 mm to 100 mm), for example about 3 inches (about 75 mm).

FIGS. 1I and 1J show a side cross-sectional view and an exploded view, respectively, of adherent device **100** as in FIGS. 1A to 1H. In many embodiments, device **100** comprises several layers.

FIGS. 1I1 and 1J1 show a side cross-sectional view and an exploded view, respectively, of embodiments of the adherent device with a temperature sensor affixed to the gel cover. In these embodiments, gel cover **180** extends over a

wider area than in the embodiments shown in FIGS. 1I and 1J. Temperature sensor **177** is disposed over a peripheral portion of gel cover **180**. Temperature sensor **177** can be affixed to gel cover **180** such that the temperature sensor can move when the gel cover stretches and tape stretch with the skin of the patient. Temperature sensor **177** may be coupled to temperature sensor circuitry **144** through a flex connection comprising at least one of wires, shielded wires, non-shielded wires, a flex circuit, or a flex PCB. This coupling of the temperature sensor allows the temperature near the skin to be measured through the breathable tape and the gel cover. The temperature sensor can be affixed to the breathable tape, for example through a cutout in the gel cover with the temperature sensor positioned away from the gel pads. A heat flux sensor can be positioned near the temperature sensor, for example to measure heat flux through to the gel cover, and the heat flux sensor coupled to heat flux circuitry similar to the temperature sensor.

The adherent device comprises electrodes **112A1**, **112B1**, **112C1** and **112D1** configured to couple to tissue through apertures in the breathable tape **110T**. Electrodes **112A1**, **112B1**, **112C1** and **112D1** can be fabricated in many ways. For example, electrodes **112A1**, **112B1**, **112C1** and **112D1** can be printed on a flexible connector **112F**, such as silver ink on polyurethane. Breathable tape **110T** comprise apertures **180A1**, **180B1**, **180C1** and **180D1**. Electrodes **112A1**, **112B1**, **112C1** and **112D1** are exposed to the gel through apertures **180A1**, **180B1**, **180C1** and **180D1** of breathable tape **110T**. Gel **114A**, gel **114B**, gel **114C** and gel **114D** can be positioned over electrodes **112A1**, **112B1**, **112C1** and **112D1** and the respective portions of breathable tape **110T** proximate apertures **180A1**, **180B1**, **180C1** and **180D1**, so as to couple electrodes **112A1**, **112B1**, **112C1** and **112D1** to the skin of the patient. The flexible connector **112F** comprising the electrodes can extend from under the gel cover to the printed circuit board to connect to the printed circuit boards and/or components supported thereon. For example, flexible connector **112F** may comprise flexible connector **122A** to provide strain relief, as described above.

In many embodiments, gel **114A**, or gel layer, comprises a hydrogel that is positioned on electrode **112A** to provide electrical conductivity between the electrode and the skin. In many embodiments, gel **114A** comprises a hydrogel that provides a conductive interface between skin and electrode, so as to reduce impedance between electrode/skin interface. In many embodiments, gel may comprise water, glycerol, and electrolytes, pharmacological agents, such as beta blockers, ace inhibitors, diuretics, steroid for inflammation, antibiotic, antifungal agent. In specific embodiments the gel may comprise cortisone steroid. The gel layer may comprise many shapes, for example, square, circular, oblong, star shaped, many any polygon shapes. In specific embodiments, the gel layer may comprise at least one of a square or circular geometry with a dimension in a range from about 0.005" to about 0.100", for example within a range from about 0.015"-0.070", in some embodiments within a range from about 0.015"-0.040", and in specific embodiments within a range from about 0.020"-0.040". In many embodiments, the gel layer of each electrode comprises an exposed surface area to contact the skin within a range from about 100 mm² to about 1500 mm², for example a range from about 250 mm² to about 750 mm², and in specific embodiments within a range from about 350 mm² to about 650 mm². Work in relation with embodiments of the present invention suggests that such dimensions and/or exposed surface areas can provide enough gel area for robust skin interface without excessive skin coverage. In many embodiments, the gel may

comprise an adhesion to skin, as may be tested with a 1800 degree peel test on stainless steel, of at least about 3 oz/in, for example an adhesion within a range from about 5-10 oz/in. In many embodiments, a spacing between gels is at least about 5 mm, for example at least about 10 mm. Work in relation to embodiments of the present invention suggests that this spacing may inhibit the gels from running together so as to avoid crosstalk between the electrodes. In many embodiments, the gels comprise a water content within a range from about 20% to about 30%, a volume resistivity within a range from about 500 to 2000 ohm-cm, and a pH within a range from about 3 to about 5.

In many embodiments, the electrodes, for example electrodes 112A to 112D, may comprise an electrode layer. A 0.001"-0.005" polyester strip with silver ink for traces can extend to silver/silver chloride electrode pads. In many embodiments, the electrodes can provide electrical conduction through hydrogel to skin, and in some embodiments may be coupled directly to the skin. Although at least 4 electrodes are shown, some embodiments comprise at least two electrodes, for example 2 electrodes. In some embodiments, the electrodes may comprise at least one of carbon-filled ABS plastic, silver, nickel, or electrically conductive acrylic tape. In specific embodiments, the electrodes may comprise at least one of carbon-filled ABS plastic, Ag/AgCl. The electrodes may comprise many geometric shapes to contact the skin, for example at least one of square, circular, oblong, star shaped, polygon shaped, or round. In specific embodiments, a dimension across a width of each electrodes is within a range from about 0.002" to about 0.050", for example from about 0.010 to about 0.040". In many a surface area of the electrode toward the skin of the patient is within a range from about 25 mm² to about 1500 mm², for example from about 75 mm² to about 150 mm². In many embodiments, the electrode comprises a tape that may cover the gel near the skin of the patient. In specific embodiments, the two inside electrodes may comprise force, or current electrodes, with a center to center spacing within a range from about 20 to about 50 mm. In specific embodiments, the two outside electrodes may comprise measurement electrodes, for example voltage electrodes, and a center-center spacing between adjacent voltage and current electrodes is within a range from about 15 mm to about 35 mm. Therefore, in many embodiments, a spacing between inner electrodes may be greater than a spacing between an inner electrode and an outer electrode.

In many embodiments, adherent patch 110 may comprise a layer of breathable tape 110T, for example a known breathable tape, such as tricot-knit polyester fabric. In many embodiments, breathable tape 110T comprises a backing material, or backing 111, with an adhesive. In many embodiments, the patch adheres to the skin of the patient's body, and comprises a breathable material to allow moisture vapor and air to circulate to and from the skin of the patient through the tape. In many embodiments, the backing is conformable and/or flexible, such that the device and/or patch does not become detached with body movement. In many embodiments, backing can sufficiently regulate gel moisture in absence of gel cover. In many embodiments, adhesive patch may comprise from 1 to 2 pieces, for example 1 piece. In many embodiments, adherent patch 110 comprises pharmacological agents, such as at least one of beta blockers, ace inhibitors, diuretics, steroid for inflammation, antibiotic, or antifungal agent. In specific embodiments, patch 110 comprises cortisone steroid. Patch 110 may comprise many geometric shapes, for example at least one of oblong, oval, butterfly, dogbone, dumbbell, round, square

with rounded corners, rectangular with rounded corners, or a polygon with rounded corners. In specific embodiments, a geometric shape of patch 110 comprises at least one of an oblong, an oval or round. In many embodiments, the geometric shape of the patch comprises a radius on each corner that is no less than about one half a width and/or diameter of tape. Work in relation to embodiments of the present invention suggests that rounding the corner can improve adherence of the patch to the skin for an extended period of time because sharp corners, for example right angle corners, can be easy to peel. In specific embodiments, a thickness of adherent patch 110 is within a range from about 0.001" to about 0.020", for example within a range from about 0.005" to about 0.010". Work in relation to embodiments of the present invention indicates that these ranges of patch thickness can improve adhesion of the device to the skin of the patient for extended periods as a thicker adhesive patch, for example tape, may peel more readily. In many embodiments, length 170 of the patch is within a range from about 2" to about 10", width 174 of the patch is within a range from about 1" to about 5". In specific embodiments, length 170 is within a range from about 4" to about 8" and width 174 is within a range from about 2" to about 4". In many embodiments, an adhesion to the skin, as measured with a 180 degree peel test on stainless steel, can be within a range from about 10 to about 100 oz/in width, for example within a range from about 30 to about 70 oz/in width. Work in relation to embodiments of the present invention suggests that adhesion within these ranges may improve the measurement capabilities of the patch because if the adhesion is too low, patch will not adhere to the skin of the patient for a sufficient period of time and if the adhesion is too high, the patch may cause skin irritation upon removal. In many embodiments adherent patch 110 comprises a moisture vapor transmission rate (MVTR, g/m²/24 hrs) per American Standard for Testing and Materials E-96 (ASTM E-96) is at least about 400, for example at least about 1000. Work in relation to embodiments of the present invention suggest that MVTR values as specified above can provide improved comfort, for example such that in many embodiments skin does not itch. In some embodiments, the breathable tape 110T of adherent patch 110 may comprise a porosity (sec./100 cc/in²) within a wide range of values, for example within a range from about 0 to about 200. The porosity of breathable tape 110T may be within a range from about 0 to about 5. The above amounts of porosity can minimize itching of the patient's skin when the patch is positioned on the skin of the patient. In many embodiments, the MVTR values above may correspond to a MVTR through both the gel cover and the breathable tape. The above MVTR values may also correspond to an MVTR through the breathable tape, the gel cover and the breathable cover. The MVTR can be selected to minimize patient discomfort, for example itching of the patient's skin.

In some embodiments, the breathable tape may contain and elute a pharmaceutical agent, such as an antibiotic, anti-inflammatory or antifungal agent, when the adherent device is placed on the patient.

In many embodiments, tape 110T of adherent patch 110 may comprise backing material, or backing 111, such as a fabric configured to provide properties of patch 110 as described above. In many embodiments backing 111 provides structure to breathable tape 110T, and many functional properties of breathable tape 110T as described above. In many embodiments, backing 111 comprises at least one of polyester, polyurethane, rayon, nylon, breathable plastic film; woven, nonwoven, spunlace, knit, film, or foam. In

15

specific embodiments, backing **111** may comprise polyester tricot knit fabric. In many embodiments, backing **111** comprises a thickness within a range from about 0.0005" to about 0.020", for example within a range from about 0.005" to about 0.010".

In many embodiments, an adhesive **116A**, for example breathable tape adhesive comprising a layer of acrylate pressure sensitive adhesive, can be disposed on underside **110A** of patch **110**. In many embodiments, adhesive **116A** adheres adherent patch **110** comprising backing **111** to the skin of the patient, so as not to interfere with the functionality of breathable tape, for example water vapor transmission as described above. In many embodiments, adhesive **116A** comprises at least one of acrylate, silicone, synthetic rubber, synthetic resin, hydrocolloid adhesive, pressure sensitive adhesive (PSA), or acrylate pressure sensitive adhesive. In many embodiments, adhesive **116A** comprises a thickness from about 0.0005" to about 0.005", in specific embodiments no more than about 0.003". Work in relation to embodiments of the present invention suggests that these thicknesses can allow the tape to breathe and/or transmit moisture, so as to provide patient comfort.

A gel cover **180**, or gel cover layer, for example a polyurethane non-woven tape, can be positioned over patch **110** comprising the breathable tape. A PCB layer, for example flex printed circuit board **120**, or flex PCB layer, can be positioned over gel cover **180** with electronic components **130** connected and/or mounted to flex printed circuit board **120**, for example mounted on flex PCB so as to comprise an electronics layer disposed on the flex PCB layer. In many embodiments, the adherent device may comprise a segmented inner component, for example the PCB may be segmented to provide at least some flexibility. In many embodiments, the electronics layer may be encapsulated in electronics housing **160** which may comprise a waterproof material, for example silicone or epoxy. In many embodiments, the electrodes are connected to the PCB with a flex connection, for example trace **123A** of flex printed circuit board **120**, so as to provide strain relive between the electrodes **112A**, **112B**, **112C** and **112D** and the PCB.

Gel cover **180** can inhibit flow of gel **114A** and liquid. In many embodiments, gel cover **180** can inhibit gel **114A** from seeping through breathable tape **110T** to maintain gel integrity over time. Gel cover **180** can also keep external moisture from penetrating into gel **114A**. For example gel cover **180** can keep liquid water from penetrating through the gel cover into gel **114A**, while allowing moisture vapor from the gel, for example moisture vapor from the skin, to transmit through the gel cover. The gel cover may comprise a porosity at least 200 sec./100 cc/in², and this porosity can ensure that there is a certain amount of protection from external moisture for the hydrogel.

In many embodiments, the gel cover can regulate moisture of the gel near the electrodes so as to keeps excessive moisture, for example from a patient shower, from penetrating gels near the electrodes. In many embodiments, the gel cover may avoid release of excessive moisture from the gel, for example toward the electronics and/or PCB modules. Gel cover **180** may comprise at least one of a polyurethane, polyethylene, polyolefin, rayon, PVC, silicone, non-woven material, foam, or a film. In many embodiments gel cover **180** may comprise an adhesive, for example a acrylate pressure sensitive adhesive, to adhere the gel cover to adherent patch **110**. In specific embodiments gel cover **180** may comprise a polyurethane film with acrylate pressure sensitive adhesive. In many embodiments, a geometric shape of gel cover **180** comprises at least one of oblong,

16

oval, butterfly, dogbone, dumbbell, round, square, rectangular with rounded corners, or polygonal with rounded corners. In specific embodiments, a geometric shape of gel cover **180** comprises at least one of oblong, oval, or round. In many embodiments, a thickness of gel cover is within a range from about 0.0005" to about 0.020", for example within a range from about 0.0005 to about 0.010". In many embodiments, gel cover **180** can extend outward from about 0-20 mm from an edge of gels, for example from about 5-15 mm outward from an edge of the gels.

In many embodiments, the breathable tape of adherent patch **110** comprises a first mesh with a first porosity and gel cover **180** comprises a breathable tape with a second porosity, in which the second porosity is less than the first porosity to inhibit flow of the gel through the breathable tape.

In many embodiments, device **100** includes a printed circuitry, for example a printed circuitry board (PCB) module that includes at least one PCB with electronics component mounted thereon on and the battery, as described above.

In many embodiments, the PCB module comprises two rigid PCB modules with associated components mounted therein, and the two rigid PCB modules are connected by flex circuit, for example a flex PCB. In specific embodiments, the PCB module comprises a known rigid FR4 type PCB and a flex PCB comprising known polyimide type PCB. In specific embodiments, the PCB module comprises a rigid PCB with flex interconnects to allow the device to flex with patient movement. The geometry of flex PCB module may comprise many shapes, for example at least one of oblong, oval, butterfly, dogbone, dumbbell, round, square, rectangular with rounded corners, or polygon with rounded corners. In specific embodiments the geometric shape of the flex PCB module comprises at least one of dogbone or dumbbell. The PCB module may comprise a PCB layer with flex PCB **120** can be positioned over gel cover **180** and electronic components **130** connected and/or mounted to flex PCB **120** so as to comprise an electronics layer disposed on the flex PCB. In many embodiments, the adherent device may comprise a segmented inner component, for example the PCB, for limited flexibility. The printed circuit may comprise polyester film with silver traces printed thereon.

In many embodiments, the electronics layer may be encapsulated in electronics housing **160**. Electronics housing **160** may comprise an encapsulant, such as a dip coating, which may comprise a waterproof material, for example silicone and/or epoxy. In many embodiments, the PCB encapsulant protects the PCB and/or electronic components from moisture and/or mechanical forces. The encapsulant may comprise silicone, epoxy, other adhesives and/or sealants. In some embodiments, the electronics housing may comprising metal and/or plastic housing and potted with aforementioned sealants and/or adhesives.

In many embodiments, the electrodes are connected to the PCB with a flex connection, for example trace **123A** of flex PCB **120**, so as to provide strain relive between the electrodes **112A**, **112B**, **112C** and **112D** and the PCB. In such embodiments, motion of the electrodes relative to the electronics modules, for example rigid PCB's **120A**, **120B**, **120C** and **120D** with the electronic components mounted thereon, does not compromise integrity of the electrode/hydrogel/skin contact. In some embodiments, the electrodes can be connected to the PCB and/or electronics module with a flex PCB **120**, such that the electrodes and adherent patch can move independently from the PCB module. In many embodiments, the flex connection comprises at least one of wires, shielded wires, non-shielded wires, a flex circuit, or a flex PCB. In specific embodiments, the flex connection may

comprise insulated, non-shielded wires with loops to allow independent motion of the PCB module relative to the electrodes.

In many embodiments, cover **162** can encase the flex PCB and/or electronics and can be adhered to at least one of the electronics, the flex PCB or adherent patch **110**, so as to protect at least the electronics components and the PCB. Cover **162** can attach to adherent patch **110** with adhesive **116B**. Cover **162** can comprise many known biocompatible cover materials, for example silicone. Cover **162** can comprise an outer polymer cover to provide smooth contour without limiting flexibility. In many embodiments, cover **162** may comprise a breathable fabric. Cover **162** may comprise many known breathable fabrics, for example breathable fabrics as described above. In some embodiments, the breathable cover may comprise a breathable water resistant cover. In some embodiments, the breathable fabric may comprise polyester, nylon, polyamide, and/or elastane (Spandex™) to allow the breathable fabric to stretch with body movement. In some embodiments, the breathable tape may contain and elute a pharmaceutical agent, such as an antibiotic, anti-inflammatory or antifungal agent, when the adherent device is placed on the patient.

In specific embodiments, cover **162** comprises at least one of polyester, 5-25% elastane/spandex, polyamide fabric; silicone, a polyester knit, a polyester knit without elastane, or a thermoplastic elastomer. In many embodiments cover **162** comprises at least 400% elongation. In specific embodiments, cover **162** comprises at least one of a polyester knit with 10-20% spandex or a woven polyamide with 10-20% spandex. In many embodiments, cover **162** comprises a water repellent coating and/or layer on outside, for example a hydrophobic coating, and a hydrophilic coating on inside to wick moisture from body. In many embodiments the water repellent coating on the outside comprises a stain resistant coating. Work in relation to embodiments of the present invention suggests that these coatings can be important to keep excessive moisture from the gels near the electrodes and to remove moisture from body so as to provide patient comfort.

The breathable cover **162** and adherent patch **110** comprise breathable tape can be configured to couple continuously for at least one week the at least one electrode to the skin so as to measure breathing of the patient. The breathable tape may comprise the stretchable breathable material with the adhesive and the breathable cover may comprises a stretchable breathable material connected to the breathable tape, as described above, such that both the adherent patch and cover can stretch with the skin of the patient. The breathable cover may also comprise a water resistant material. Arrows **182** show stretching of adherent patch **110**, and the stretching of adherent patch can be at least two dimensional along the surface of the skin of the patient. As noted above, connectors **122A**, **122B**, **122C** and **122D** between PCB **130** and electrodes **112A**, **112B**, **112C** and **112D** may comprise insulated wires that provide strain relief between the PCB and the electrodes, such that the electrodes can move with the adherent patch as the adherent patch comprising breathable tape stretches. Arrows **184** show stretching of cover **162**, and the stretching of the cover can be at least two dimensional along the surface of the skin of the patient.

Cover **162** can be attached to adherent patch **110** with adhesive **116B** such that cover **162** stretches and/or retracts when adherent patch **110** stretches and/or retracts with the skin of the patient. For example, cover **162** and adherent patch **110** can stretch in two dimensions along length **170**

and width **174** with the skin of the patient, and stretching along length **170** can increase spacing between electrodes. Stretching of the cover and adherent patch **110**, for example in two dimensions, can extend the time the patch is adhered to the skin as the patch can move with the skin such that the patch remains adhered to the skin. Electronics housing **160** can be smooth and allow breathable cover **162** to slide over electronics housing **160**, such that motion and/or stretching of cover **162** is slidably coupled with housing **160**. The printed circuit board can be slidably coupled with adherent patch **110** that comprises breathable tape **110T**, such that the breathable tape can stretch with the skin of the patient when the breathable tape is adhered to the skin of the patient, for example along two dimensions comprising length **170** and width **174**.

The stretching of the adherent device **100** along length **170** and width **174** can be characterized with a composite modulus of elasticity determined by stretching of cover **162**, adherent patch **110** comprising breathable tape **110T** and gel cover **180**. For the composite modulus of the composite fabric cover-breathable tape-gel cover structure that surrounds the electronics, the composite modulus may comprise no more than about 1 MPa, for example no more than about 0.3 MPa at strain of no more than about 5%. These values apply to any transverse direction against the skin.

The stretching of the adherent device **100** along length **170** and width **174**, may also be described with a composite stretching elongation of cover **162**, adherent patch **110** comprising breathable tape **110T** and gel cover **180**. The composite stretching elongation may comprise a percentage of at least about 10% when 3 kg load is applied, for example at least about 100% when the 3 kg load applied. These percentages apply to any transverse direction against the skin.

The printed circuit board may be adhered to the adherent patch **110** comprising breathable tape **110T** at a central portion, for example a single central location, such that adherent patch **110** can stretch around this central region. The central portion can be sized such that the adherence of the printed circuit board to the breathable tape does not have a substantial effect of the modulus of the composite modulus for the fabric cover, breathable tape and gel cover, as described above. For example, the central portion adhered to the patch may be less than about 100 mm², for example with dimensions of approximately 10 mm by 10 mm (about 0.5" by 0.5"). Such a central region may comprise no more than about 10% of the area of patch **110**, such that patch **110** can stretch with the skin of the patient along length **170** and width **174** when the patch is adhered to the patient.

The cover material may comprise a material with a low recovery, which can minimize retraction of the breathable tape from the pulling by the cover. Suitable cover materials with a low recovery include at least one of polyester or nylon, for example polyester or nylon with a loose knit. The recovery of the cover material may be within a range from about 0% recovery to about 25% recovery. Recovery can refer to the percentage of retraction the cover material that occurs after the material has been stretched from a first length to a second length. For example, with 25% recovery, a cover that is stretched from a 4 inch length to a 5 inch length will retract by 25% to a final length of 4.75 inches.

Electronics components **130** can be affixed to printed circuit board **120**, for example with solder, and the electronics housing can be affixed over the PCB and electronics components, for example with dip coating, such that electronics components **130**, printed circuit board **120** and electronics housing **160** are coupled together. Electronics

components 130, printed circuit board 120, and electronics housing 160 are disposed between the stretchable breathable material of adherent patch 110 and the stretchable breathable material of cover 160 so as to allow the adherent patch 110 and cover 160 to stretch together while electronics components 130, printed circuit board 120, and electronics housing 160 do not stretch substantially, if at all. This decoupling of electronics housing 160, printed circuit board 120 and electronic components 130 can allow the adherent patch 110 comprising breathable tape to move with the skin of the patient, such that the adherent patch can remain adhered to the skin for an extended time of at least one week, for example two or more weeks.

An air gap 169 may extend from adherent patch 110 to the electronics module and/or PCB, so as to provide patient comfort. Air gap 169 allows adherent patch 110 and breathable tape 110T to remain supple and move, for example bend, with the skin of the patient with minimal flexing and/or bending of printed circuit board 120 and electronic components 130, as indicated by arrows 186. Printed circuit board 120 and electronics components 130 that are separated from the breathable tape 110T with air gap 169 can allow the skin to release moisture as water vapor through the breathable tape, gel cover, and breathable cover. This release of moisture from the skin through the air gap can minimize, and even avoid, excess moisture, for example when the patient sweats and/or showers.

The breathable tape of adherent patch 110 may comprise a first mesh with a first porosity and gel cover 180 may comprise a breathable tape with a second porosity, in which the second porosity is less than the first porosity to minimize, and even inhibit, flow of the gel through the breathable tape. The gel cover may comprise a polyurethane film with the second porosity.

Cover 162 may comprise many shapes. In many embodiments, a geometry of cover 162 comprises at least one of oblong, oval, butterfly, dogbone, dumbbell, round, square, rectangular with rounded corners, or polygonal with rounded corners. In specific embodiments, the geometric of cover 162 comprises at least one of an oblong, an oval or a round shape.

Cover 162 may comprise many thicknesses and/or weights. In many embodiments, cover 162 comprises a fabric weight: within a range from about 100 to about 200 g/m², for example a fabric weight within a range from about 130 to about 170 g/m².

In many embodiments, cover 162 can attach the PCB module to adherent patch 110 with cover 162, so as to avoid interaction of adherent patch [110C] 110 with the PCB having the electronics mounted therein. Cover 162 can be attached to breathable tape 110T and/or electronics housing 160 comprising over the encapsulated PCB. In many embodiments, adhesive 116B attaches cover 162 to adherent patch 110. In many embodiments, cover 162 attaches to adherent patch 110 with adhesive 116B, and cover 162 is adhered to the PCB module with an adhesive 161 on the upper surface of the electronics housing. Thus, the PCB module can be suspended above the adherent patch via connection to cover 162, for example with a gap 169 between the PCB module and adherent patch. In many embodiments, gap 169 permits air and/or water vapor to flow between the adherent patch and cover, for example through adherent patch 110 and cover 162, so as to provide patient comfort.

In many embodiments, adhesive 116B is configured such that adherent patch 110 and cover 162 can be breathable from the skin to above cover 162 and so as to allow moisture

vapor and air to travel from the skin to outside cover 162. In many embodiments, adhesive 116B is applied in a pattern on adherent patch 110 such that the patch and cover can be flexible so as to avoid detachment with body movement. Adhesive 116B can be applied to upper side 110B of patch 110 and comprise many shapes, for example a continuous ring, dots, dashes around the perimeter of adherent patch 110 and cover 162. Adhesive 116B may comprise at least one of acrylate, silicone, synthetic rubber, synthetic resin, pressure sensitive adhesive (PSA), or acrylate pressure sensitive adhesive. Adhesive 16B may comprise a thickness within a range from about 0.0005" to about 0.005", for example within a range from about 0.001-0.005". In many embodiments, adhesive 116B comprises a width near the edge of patch 110 and/or cover 162 within a range from about 2 to about 15 mm, for example from about 3 to about 7 near the periphery. In many embodiments with such widths and/or thickness near the edge of the patch and/or cover, the tissue adhesion may be at least about 30 oz/in, for example at least about 40 oz/in, such that the cover remains attached to the adhesive patch when the patient moves.

In many embodiments, the cover is adhered to adherent patch 110 comprising breathable tape 110T at least about 1 mm away from an outer edge of adherent patch 110. This positioning protects the adherent patch comprising breathable tape 110T from peeling away from the skin and minimizes edge peeling, for example because the edge of the patch can be thinner. In some embodiments, the edge of the cover may be adhered at the edge of the adherent patch, such that the cover can be slightly thicker at the edge of the patch which may, in some instances, facilitate peeling of the breathable tape from the skin of the patient.

Gap 169 extend from adherent patch 110 to the electronics module and/or PCB a distance within a range from about 0.25 mm to about 4 mm, for example within a range from about 0.5 mm to about 2 mm.

In many embodiments, the adherent device comprises a patch component and at least one electronics module. The patch component may comprise adherent patch 110 comprising the breathable tape with adhesive coating 116A, at least one electrode, for example electrode 114A and gel 114. The at least one electronics module can be separable from the patch component. In many embodiments, the at least one electronics module comprises the flex printed circuit board 120, electronic components 130, electronics housing 160 and cover 162, such that the flex printed circuit board, electronic components, electronics housing and cover are reusable and/or removable for recharging and data transfer, for example as described above. In many embodiments, adhesive 116B is coated on upper side 110A of adherent patch 110B, such that the electronics module can be adhered to and/or separated from the adhesive component. In specific embodiments, the electronic module can be adhered to the patch component with a releasable connection, for example with Velcro™, a known hook and loop connection, and/or snap directly to the electrodes. Two electronics modules can be provided, such that one electronics module can be worn by the patient while the other is charged, as described above. Monitoring with multiple adherent patches for an extended period is described in U.S. Pat. App. No. 60/972,537, the full disclosure of which has been previously incorporated herein by reference. Many patch components can be provided for monitoring over the extended period. For example, about 12 patches can be used to monitor the patient for at least 90 days with at least one electronics module, for example with two reusable electronics modules.

At least one electrode 112A can extend through at least one aperture 180A in the breathable tape 110.

In some embodiments, the adhesive patch may comprise a medicated patch that releases a medicament, such as antibiotic, beta-blocker, ACE inhibitor, diuretic, or steroid to reduce skin irritation. The adhesive patch may comprise a thin, flexible, breathable patch with a polymer grid for stiffening. This grid may be anisotropic, may use electronic components to act as a stiffener, may use electronics-enhanced adhesive elution, and may use an alternating elution of adhesive and steroid.

FIG. 1K shows at least one electrode 190 configured to electrically couple to a skin of the patient through a breathable tape 192. In many embodiments, at least one electrode 190 and breathable tape 192 comprise electrodes and materials similar to those described above. Electrode 190 and breathable tape 192 can be incorporated into adherent devices as described above, so as to provide electrical coupling between the skin and an electrode through the breathable tape, for example with the gel.

FIGS. 2A and 2B show components of an adherent device 200 comprising an adhesive patch 210 and connection structures to provide strain relief so as to decouple the patch from an electronics module 220. Adherent device 200 comprises many structures similar to those shown above. Adherent device 200 comprises electrodes 212A, 212B, 212C and 212D affixed to adhesive patch 210. Adherent device 200 may comprise a gel, for example gel 214A over the electrodes, for example over electrode 212A. Electrodes 212A, 212B, 212C and 212D are connected to electronics module 220 with structures 223A, 223B, 223C and 223D. Electronics module 220 may comprise PCB with components mounted thereon, as described above. In many embodiments, structures 223A, 223B, 223C and 223D connect adhesive patch 210 to electronics module 220 with a flexible connection. In many embodiments, structures 223A, 223B, 223C and 223D comprise curved flexible wires, for example spirals and/or loops of wire that connect electrodes 212A, 212B, 212C and 212D to an electronics module 220. Structures 223A, 223B, 223C and 223D may comprise polyester film with silver traces coupled to silver/silver chloride electrodes to provide strain relief. Adhesive patch 210 comprises a lower side 210A toward the skin of the patient and an upper side 210B away from the skin of the patient. Adhesive 216B is disposed on upper side 210B of patch 210 to connect the adhesive patch to a cover, as described above. Electronics module 220 can be connected to the cover, as described above, such that module 220 is suspended above adhesive patch 210 with a gap 269. Gap 269 can decouple movement between patch 210 and electronic module 220. In many embodiments, gap 260 allows adhesive patch 210 and/or device 200 to breath, for example from the skin through the patch and cover to the outside of the cover, as described above. *A gel cover 280, or gel cover layer, for example a polyurethane non-woven tape, can be positioned over patch 210 comprising the breathable tape.*

In many embodiments, gap 269 can extend from adherent patch 210 to the electronics module 220 and/or PCB a distance within a range from about 0.25 mm to about 4 mm, for example within a range from about 0.5 mm to about 2 mm.

While the exemplary embodiments have been described in some detail, by way of example and for clarity of understanding, those of skill in the art will recognize that a variety of modifications, adaptations, and changes may be employed. Hence, the scope of the present invention should be limited solely by the appended claims.

What claimed is:

1. An adherent device to monitor a patient for an extended period, the device comprising:
 - a first adherent patch comprising a breathable tape with an adhesive coating to adhere the breathable tape to a skin of the patient, the adherent patch also comprising a plurality of electrodes affixed to the breathable tape and capable of electrically coupling to the skin of the patient; and
 - an electronics module comprising electrocardiogram circuitry coupled to at least two of the plurality of electrodes and impedance circuitry coupled to at least two of the plurality of electrodes, the electronics module also comprising wireless communications circuitry coupled to the electrocardiogram circuitry and to the impedance circuitry to transmit to [a remote server] *another device* an electrocardiogram signal derived from an output of the electrocardiogram circuitry and a hydration signal derived from an output of the impedance circuitry;
 - wherein the electronics module is coupled to the breathable tape to support the electronics module when the tape is adhered to the patient;
 - [and] wherein the electronics module is separable from the adherent patch such that the electronics module can be reused with a second adherent patch to provide monitoring for an extended period;
 - wherein the adherent patch further comprises a respective gel disposed over a contact surface of each of the plurality of electrodes to electrically connect the respective electrode to the skin of the patient; and*
 - wherein the adherent patch further comprises a gel cover positioned over the breathable tape to inhibit a flow of the gel through the breathable tape, and wherein the electronics module is located over the gel cover such that the gel cover is disposed between the breathable tape and the electronics module, wherein the gel cover is configured to inhibit transmission of liquid water and permit transmission of moisture vapor.*
2. The adherent device of claim 1, wherein the electronics module further comprises an accelerometer, and wherein the wireless communications circuitry is coupled to the accelerometer to transmit to the [remote server] *other device* an inclination signal derived from an output of the accelerometer.
3. The adherent device of claim 1, wherein the adherent patch is disposable.
- [4. The adherent device of claim 1, wherein the adherent patch further comprises a respective gel disposed over a contact surface of each of the plurality of electrodes to electrically connect the respective electrode to the skin of the patient.]
- [5. The adherent device of claim 4, wherein the adherent patch further comprises a gel cover positioned over the breathable tape to inhibit a flow of the gel through the breathable tape and wherein the electronics module is located over the gel cover such that the gel cover is disposed between the breathable tape and the electronics module.]
6. The adherent device of claim 1, further comprising a breathable cover disposed over the electronics module.
7. The adherent device of claim 1, wherein the plurality of electrodes comprises *at least* four electrodes [arranged linearly, the four electrodes comprising two end electrodes and two inner electrodes, and wherein the distance between the inner electrodes is larger than the distance between either end electrode and its adjacent inner electrode].

23

8. An adherent device to monitor a patient for an extended period, the device comprising:

a first adherent patch comprising a breathable tape with an adhesive coating to adhere the breathable tape to a skin of the patient, the adherent patch also comprising a plurality of electrodes affixed to the breathable tape and capable of electrically coupling to the skin of the patient; and

an electronics module comprising impedance circuitry coupled to at least two of the plurality of electrodes and electrocardiogram circuitry coupled to at least two of the plurality of electrodes, the electronics module also comprising wireless communications circuitry coupled to the impedance circuitry and to the electrocardiogram circuitry to transmit to [a remote server] another device a hydration signal derived from an output of the impedance circuitry and an electrocardiogram signal derived from an output of the electrocardiogram circuitry;

wherein the electronics module is coupled to the breathable tape to support the electronics module when the tape is adhered to the patient;

[and] wherein the electronics module is separable from the adherent patch such that the electronics module can be reused with a second adherent patch to provide monitoring for an extended period; and

wherein the electronics module is coupled to the plurality of electrodes using a flexible connection;

wherein the adherent patch further comprises a respective gel disposed over a contact surface of each of the plurality of electrodes to electrically connect the respective electrode to the skin of the patient; and

wherein the adherent patch further comprises a gel cover positioned over the breathable tape to inhibit a flow of the gel through the breathable tape, and wherein the electronics module is located over the gel cover such that the gel cover is disposed between the breathable tape and the electronics module, wherein the gel cover is configured to inhibit transmission of liquid water and permit transmission of moisture vapor.

9. The adherent device of claim 8, wherein the electronics module further comprises an accelerometer, and wherein the wireless communications circuitry is coupled to the accelerometer to transmit to the [remote server] other device an inclination signal derived from an output of the accelerometer.

10. The adherent device of claim 8, wherein the adherent patch is disposable.

11. The adherent device of claim 8, wherein the plurality of electrodes comprises at least four electrodes [arranged linearly, the four electrodes comprising two end electrodes and two inner electrodes, and wherein the distance between the inner electrodes is larger than the distance between either end electrode and its adjacent inner electrode].

12. A system for monitoring a patient, the system comprising:

an adherent device comprising an adherent patch and an electronics module; and
an intermediate device;

wherein the adherent patch comprises a breathable tape with an adhesive coating to adhere the breathable tape to a skin of the patient, and a plurality of electrodes affixed to the breathable tape and capable of electrically coupling to the skin of the patient;

wherein the electronics module is coupled to the breathable tape to support the electronics module when the tape is adhered to the patient;

24

wherein the electronics module is separable from the adherent patch such that the electronics module can be reused with a second adherent patch to provide monitoring for an extended period;

wherein the electronics module comprises electrocardiogram circuitry coupled to at least two of the plurality of electrodes and impedance circuitry coupled to at least two of the plurality of electrodes, and also comprises wireless communications circuitry coupled to the electrocardiogram circuitry and to the impedance circuitry to transmit to the intermediate device an electrocardiogram signal derived from an output of the electrocardiogram circuitry and a hydration signal derived from an output of the impedance circuitry;

wherein the adherent patch further comprises a respective gel disposed over a contact surface of each of the plurality of electrodes to electrically connect the respective electrode to the skin of the patient;

wherein the adherent patch further comprises a gel cover positioned over the breathable tape to inhibit a flow of the gel through the breathable tape and wherein the electronics module is located over the gel cover such that the gel cover is disposed between the breathable tape and the electronics module, wherein the gel cover is configured to inhibit transmission of liquid water and permit transmission of moisture vapor; and

wherein the intermediate device transmits the electrocardiogram signal and the hydration signal to a remote server.

13. A method of monitoring a patient, the method comprising:

providing an adherent device comprising a first adherent patch and an electronics module, wherein the first adherent patch comprises a breathable tape with an adhesive coating to adhere the breathable tape to a skin of the patient and the first adherent patch comprises a plurality of electrodes affixed to the breathable tape and capable of electrically coupling to the skin of the patient, wherein the electronics module is coupled to the breathable tape to support the electronics module when the tape is adhered to the patient, and wherein the electronics module comprises electrocardiogram circuitry coupled to at least two of the plurality of electrodes and impedance circuitry coupled to at least two of the plurality of electrodes, and also comprises wireless communications circuitry coupled to the electrocardiogram circuitry and to the impedance circuitry to transmit to [a remote server] another device an electrocardiogram signal derived from an output of the electrocardiogram circuitry and a hydration signal derived from an output of the impedance circuitry, wherein the adherent patch further comprises a respective gel disposed over a contact surface of each of the plurality of electrodes to electrically connect the respective electrode to the skin of the patient, and wherein the adherent patch further comprises a gel cover positioned over the breathable tape to inhibit a flow of the gel through the breathable tape and wherein the electronics module is located over the gel cover such that the gel cover is disposed between the breathable tape and the electronics module, wherein the gel cover is configured to inhibit transmission of liquid water and permit transmission of moisture vapor;

adhering the adherent device to the patient;

monitoring the patient for a first period of time, including transmitting the electrocardiogram signal and the hydration signal to [the remote server] the other device;

25

separating the first adherent patch from the electronics module;

providing a second adherent patch like the first;

coupling the electronics module to the second adherent patch and adhering the second adherent patch to the skin of the patient; and

monitoring the patient for a second period of time, including transmitting the electrocardiogram signal and the hydration signal to the [remote server] other device.

14. The method of claim 13, further comprising disposing of the first adherent patch.

15. The adherent device of claim 1, wherein the gel cover is connected to the breathable tape.

16. The adherent device of claim 1, wherein the electronics module comprises a printed circuit board connected to one or more of the electrocardiogram circuitry, the impedance circuitry, or the wireless communication circuitry, and wherein the gel cover is disposed between the breathable tape and the printed circuit board.

17. The adherent device of claim 1, wherein the breathable tape has a first porosity, and the gel cover has a second porosity less than the first porosity.

18. The adherent device of claim 1, wherein the electronics module is configured to determine at least one of heart rate variability or heart rate turbulence based on the electrocardiogram signal.

19. The adherent device of claim 7, wherein the at least four electrodes comprises four electrodes arranged linearly, the four electrodes comprising two end electrodes and two inner electrodes, and wherein the distance between the inner electrodes is larger than the distance between either end electrode and its adjacent inner electrode.

20. The adherent device of claim 8, wherein the gel cover is connected to the breathable tape.

21. The adherent device of claim 8, wherein the electronics module comprises a printed circuit board connected to one or more of the electrocardiogram circuitry, the impedance circuitry, or the wireless communication circuitry, and wherein the gel cover is disposed between the breathable tape and the printed circuit board.

22. The adherent device of claim 8, wherein the breathable tape has a first porosity, and the gel cover has a second porosity less than the first porosity.

23. The adherent device of claim 8, wherein the electronics module is configured to determine at least one of heart rate variability or heart rate turbulence based on the electrocardiogram signal.

26

24. The adherent device of claim 11, wherein the at least four electrodes comprises four electrodes arranged linearly, the four electrodes comprising two end electrodes and two inner electrodes, and wherein the distance between the inner electrodes is larger than the distance between either end electrode and its adjacent inner electrode.

25. The system of claim 12, wherein the gel cover is connected to the breathable tape.

26. The system of claim 12, wherein the electronics module comprises a printed circuit board connected to one or more of the electrocardiogram circuitry, the impedance circuitry, or the wireless communication circuitry, and wherein the gel cover is disposed between the breathable tape and the printed circuit board.

27. The system of claim 12, wherein the breathable tape has a first porosity, and the gel cover has a second porosity less than the first porosity.

28. The system of claim 12, wherein the electronics module is configured to determine at least one of heart rate variability or heart rate turbulence based on the electrocardiogram signal.

29. A device configured to monitor a patient, the device comprising:

a patch comprising a breathable layer configured to contact to a skin of the patient, the patch also comprising a plurality of electrodes affixed to the breathable layer and configured to electrically couple to the skin of the patient; and

an electronics module configured to be coupled to the breathable layer, and to derive an electrocardiogram signal and a hydration signal via plurality of electrodes;

wherein the patch further comprises a respective gel disposed over a contact surface of each of the plurality of electrodes to electrically connect the respective electrode to the skin of the patient; and

wherein the patch further comprises a gel cover positioned over the breathable layer to inhibit a flow of the gel through the breathable layer, and wherein the electronics module is located over the gel cover such that the gel cover is disposed between the breathable layer and the electronics module, wherein the gel cover is configured to inhibit transmission of liquid water and permit transmission of moisture vapor.

* * * * *