



US00RE46880E

(19) **United States**
(12) **Reissued Patent**
Yun et al.

(10) **Patent Number:** **US RE46,880 E**
(45) **Date of Reissued Patent:** **May 29, 2018**

(54) **BROADCASTING SIGNAL RECEIVER AND METHOD FOR TRANSMITTING/RECEIVING BROADCASTING SIGNAL**

(71) Applicant: **LG Electronics Inc.**, Seoul (KR)

(72) Inventors: **Chang Sik Yun**, Daejeon (KR); **In Hwan Choi**, Gwacheon-si (KR); **Kook Yeon Kwak**, Anyang-si (KR); **Hyung Gon Lee**, Seoul (KR); **Won Gyu Song**, Seoul (KR); **Jin Pil Kim**, Seoul (KR); **Jong Moon Kim**, Gwangmyeong-si (KR); **Jin Woo Kim**, Seoul (KR); **Byoung Gill Kim**, Seoul (KR)

(73) Assignee: **LG ELECTRONICS INC.**, Seoul (KR)

(21) Appl. No.: **14/639,744**

(22) Filed: **Mar. 5, 2015**

Related U.S. Patent Documents

Reissue of:

(64) Patent No.: **8,392,953**
Issued: **Mar. 5, 2013**
Appl. No.: **13/208,239**
Filed: **Aug. 11, 2011**

U.S. Applications:

(63) Continuation of application No. 12/027,801, filed on Feb. 7, 2008, now Pat. No. 8,023,535.
(Continued)

(30) **Foreign Application Priority Data**

Feb. 9, 2007 (KR) 10-2007-0013929

(51) **Int. Cl.**
H04N 7/16 (2011.01)
G06F 3/0482 (2013.01)
(Continued)

(52) **U.S. Cl.**
CPC **G06F 3/0482** (2013.01); **H04N 5/44543** (2013.01); **H04N 5/782** (2013.01);
(Continued)

(58) **Field of Classification Search**
CPC ... **H04N 5/225**; **H04N 5/232**; **H01L 2924/00**; **H01L 2924/0002**; **H03N 21/235**;
(Continued)

(56) **References Cited**

U.S. PATENT DOCUMENTS

5,634,138 A 5/1997 Ananthan et al.
5,649,284 A 7/1997 Yoshinobu
(Continued)

FOREIGN PATENT DOCUMENTS

KR 10-2000-0040481 7/2000
KR 10-2000-0040481 A 7/2000
(Continued)

Primary Examiner — Jalatee Worjloh

(74) *Attorney, Agent, or Firm* — Dentons US LLP

(57) **ABSTRACT**

A broadcasting signal receiver and a method for transmitting/receiving a broadcasting signal are disclosed. An identifier of a cell is configured in second program table information or signaling information of the broadcasting signal. If the cell is changed, channel information of the changed cell can be obtained from second program table information in which transmission channel information of each cell for a broadcasting program is configured. Accordingly, the broadcasting signal receiver can continuously output the program although the cell is changed.

8 Claims, 21 Drawing Sheets

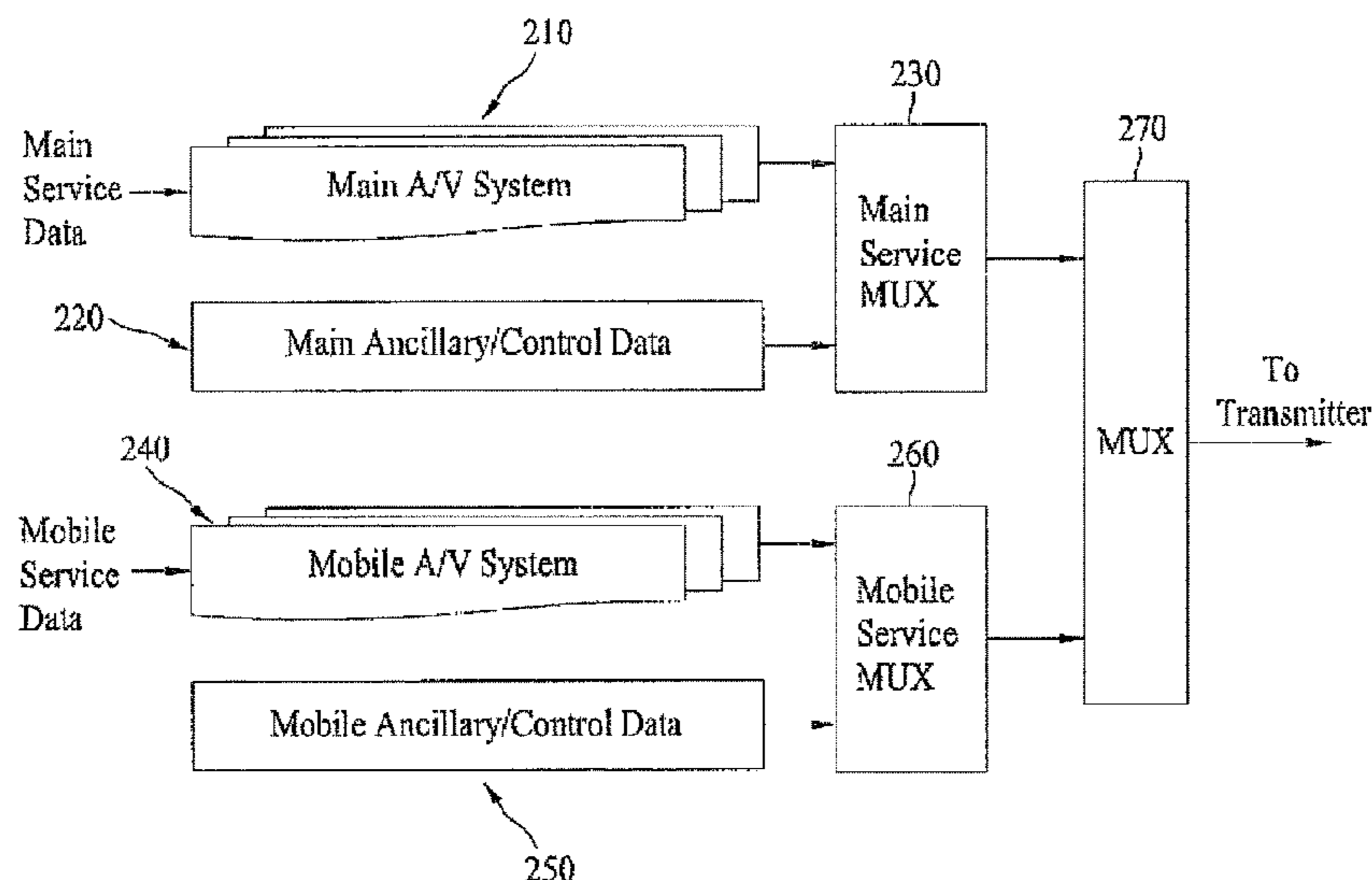

Related U.S. Application Data

(60) Provisional application No. 60/978,733, filed on Oct. 9, 2007, provisional application No. 60/947,984, filed on Jul. 4, 2007, provisional application No. 60/911,808, filed on Apr. 13, 2007.

(51) **Int. Cl.**

H04N 21/234 (2011.01)
H04N 5/445 (2011.01)
H04N 5/782 (2006.01)
H04N 21/472 (2011.01)
H04N 21/2747 (2011.01)
H04N 21/24 (2011.01)
H04N 21/454 (2011.01)
H04N 21/435 (2011.01)
H04N 7/173 (2011.01)
H04N 21/433 (2011.01)
H04N 21/482 (2011.01)
H04N 21/242 (2011.01)
H04N 21/432 (2011.01)
H04N 21/235 (2011.01)

(52) **U.S. Cl.**

CPC *H04N 7/17318* (2013.01); *H04N 7/17336* (2013.01); *H04N 21/234* (2013.01); *H04N 21/235* (2013.01); *H04N 21/242* (2013.01); *H04N 21/2407* (2013.01); *H04N 21/2747* (2013.01); *H04N 21/435* (2013.01); *H04N 21/4325* (2013.01); *H04N 21/4333* (2013.01); *H04N 21/454* (2013.01); *H04N 21/47214* (2013.01); *H04N 21/482* (2013.01)

(58) **Field of Classification Search**

CPC H03N 21/41407; H03N 21/4382; H03N 21/4345; H03N 21/435; H03N 21/4305
 USPC 725/62; 370/535, 537
 See application file for complete search history.

(56) **References Cited**

U.S. PATENT DOCUMENTS

5,797,093 A 8/1998 Houde

6,067,457 A 5/2000 Erickson et al.
 6,243,469 B1 6/2001 Kataoka et al.
 6,308,066 B1 10/2001 Ranta et al.
 6,309,066 B1 10/2001 Kan
 6,370,391 B1 4/2002 Lietsalmi et al.
 6,470,182 B1 10/2002 Nelson
 6,505,347 B1* 1/2003 Kaneko H04N 21/235
 375/E7.024
 6,977,914 B2 12/2005 Paila et al.
 2002/0194570 A1* 12/2002 Birru H04N 21/4382
 714/792
 2003/0099303 A1* 5/2003 Birru H03M 13/15
 375/265
 2004/0090997 A1 5/2004 Choi et al.
 2004/0141570 A1 7/2004 Yamazaki et al.
 2005/0054345 A1 3/2005 Lee
 2005/0168641 A1 8/2005 Seo
 2006/0029159 A1 2/2006 Oh et al.
 2006/0184965 A1 8/2006 Lee et al.
 2007/0076484 A1 4/2007 Cho et al.
 2007/0211769 A1* 9/2007 Lee H04H 20/57
 370/535
 2007/0268979 A1* 11/2007 Chang H03M 13/253
 375/265
 2008/0056185 A1 3/2008 Alapuranen et al.
 2008/0313692 A1 12/2008 Yun et al.
 2009/0052569 A1* 2/2009 Park H03M 13/253
 375/265
 2010/0180294 A1 7/2010 Yun et al.
 2017/0150234 A1* 5/2017 Corl H04N 21/84

FOREIGN PATENT DOCUMENTS

KR 10-2006-0055959 5/2006
 KR 10-2006-0055959 A 5/2006
 KR 10-2006-0068449 6/2006
 KR 10-2006-0068449 A 6/2006
 KR 10-2007-0013168 1/2007
 KR 10-2007-0013168 A 1/2007
 WO 01/05157 1/2001
 WO 0105157 A2 1/2001

* cited by examiner

FIG. 1

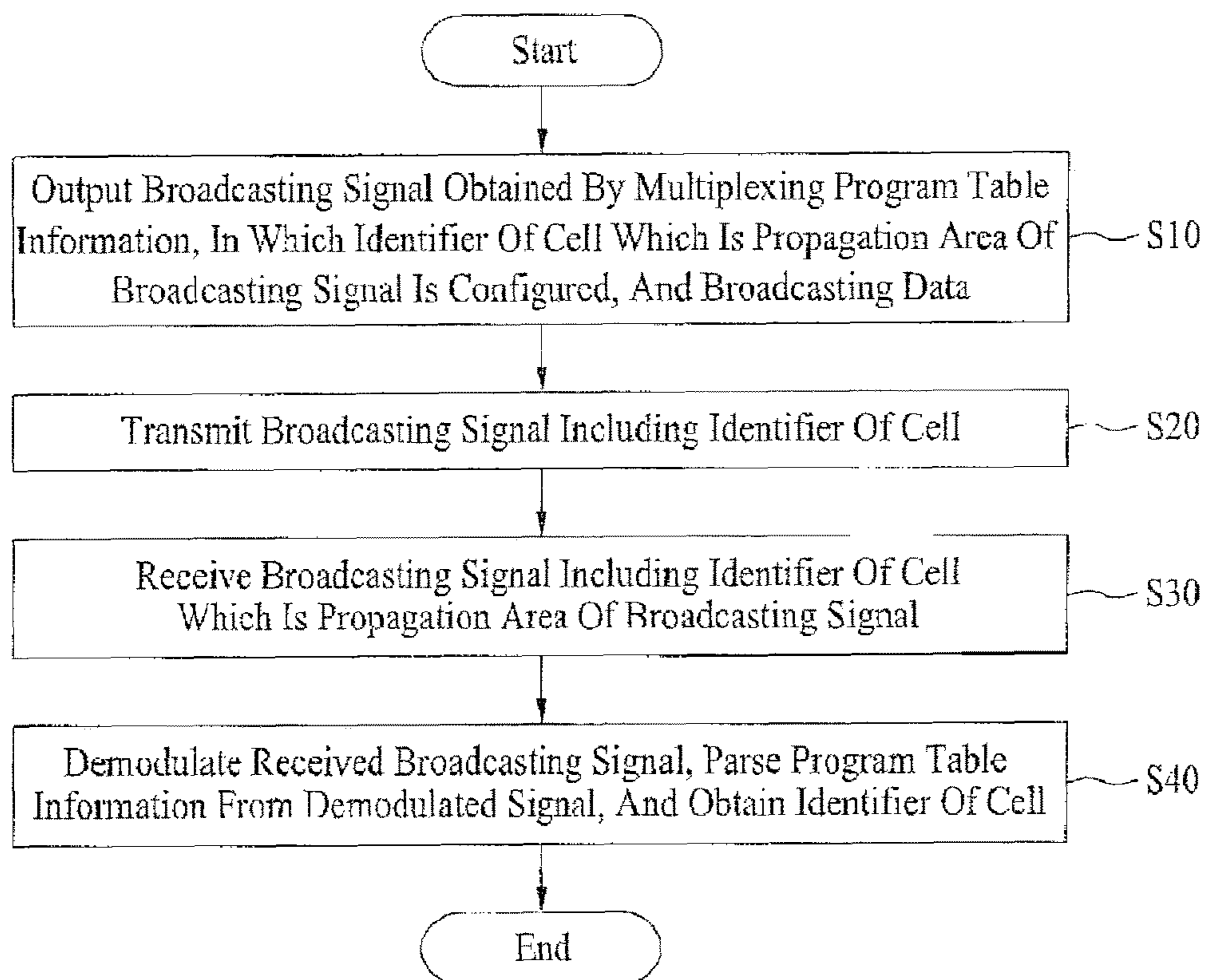

FIG. 2

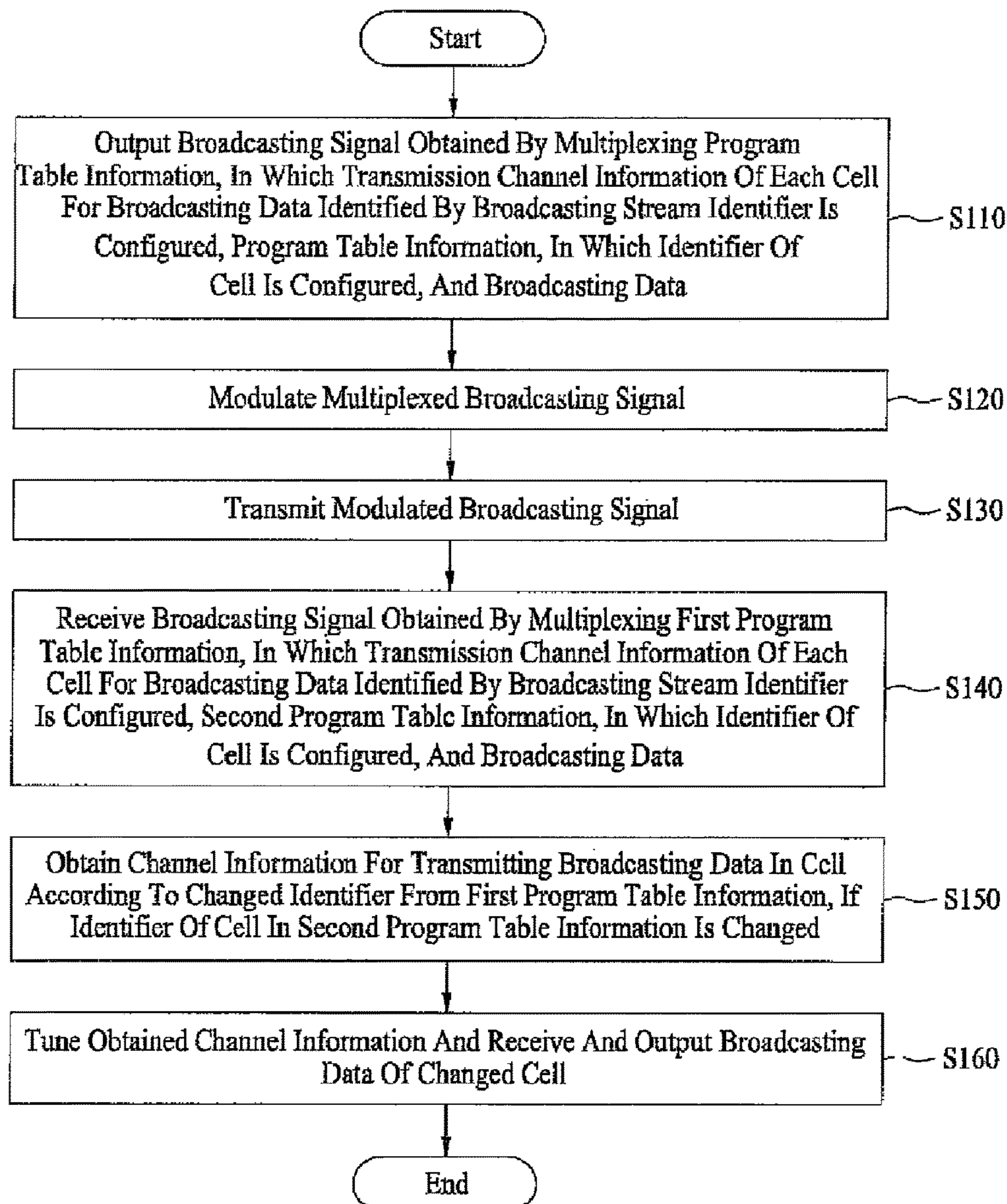

FIG. 3

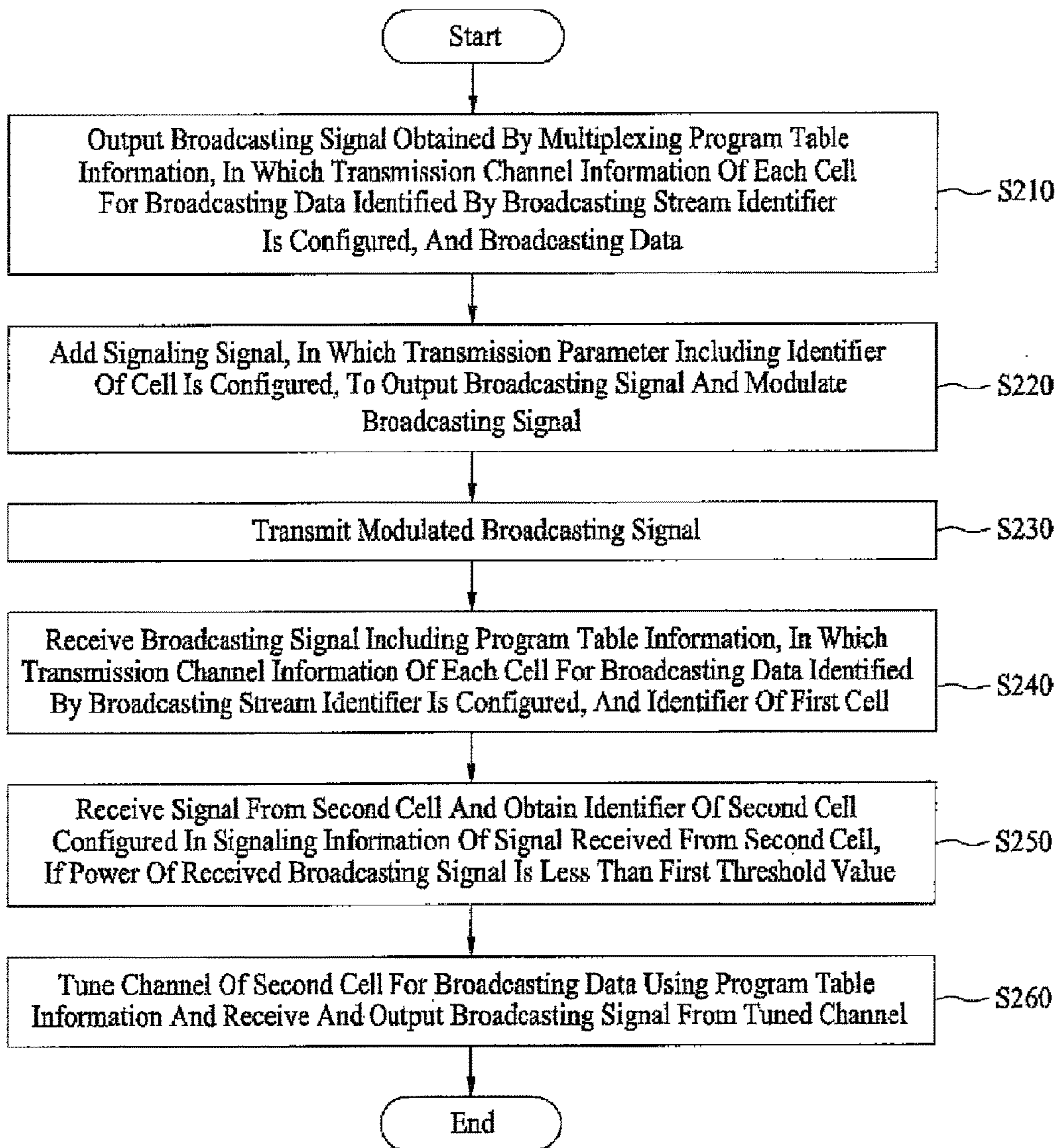

FIG. 4

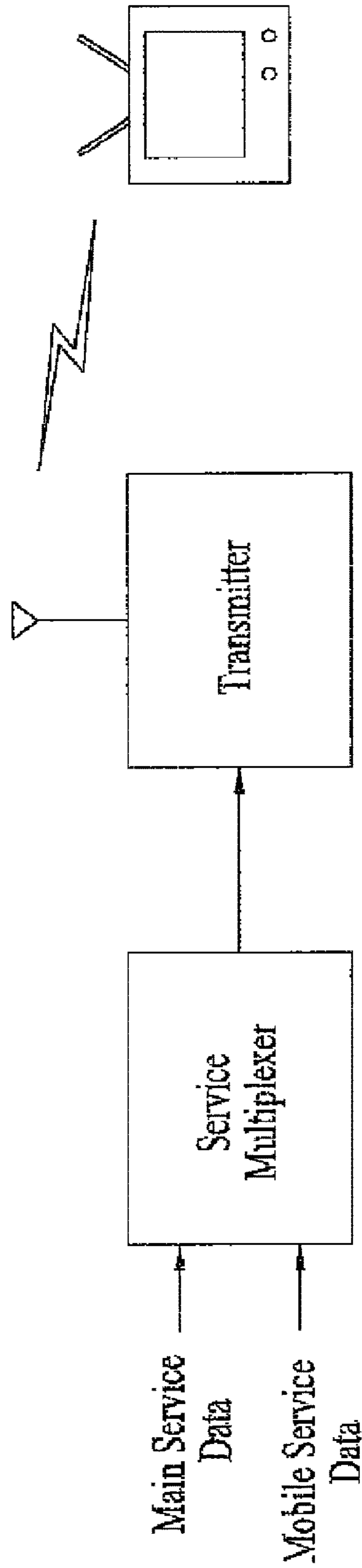

FIG. 5

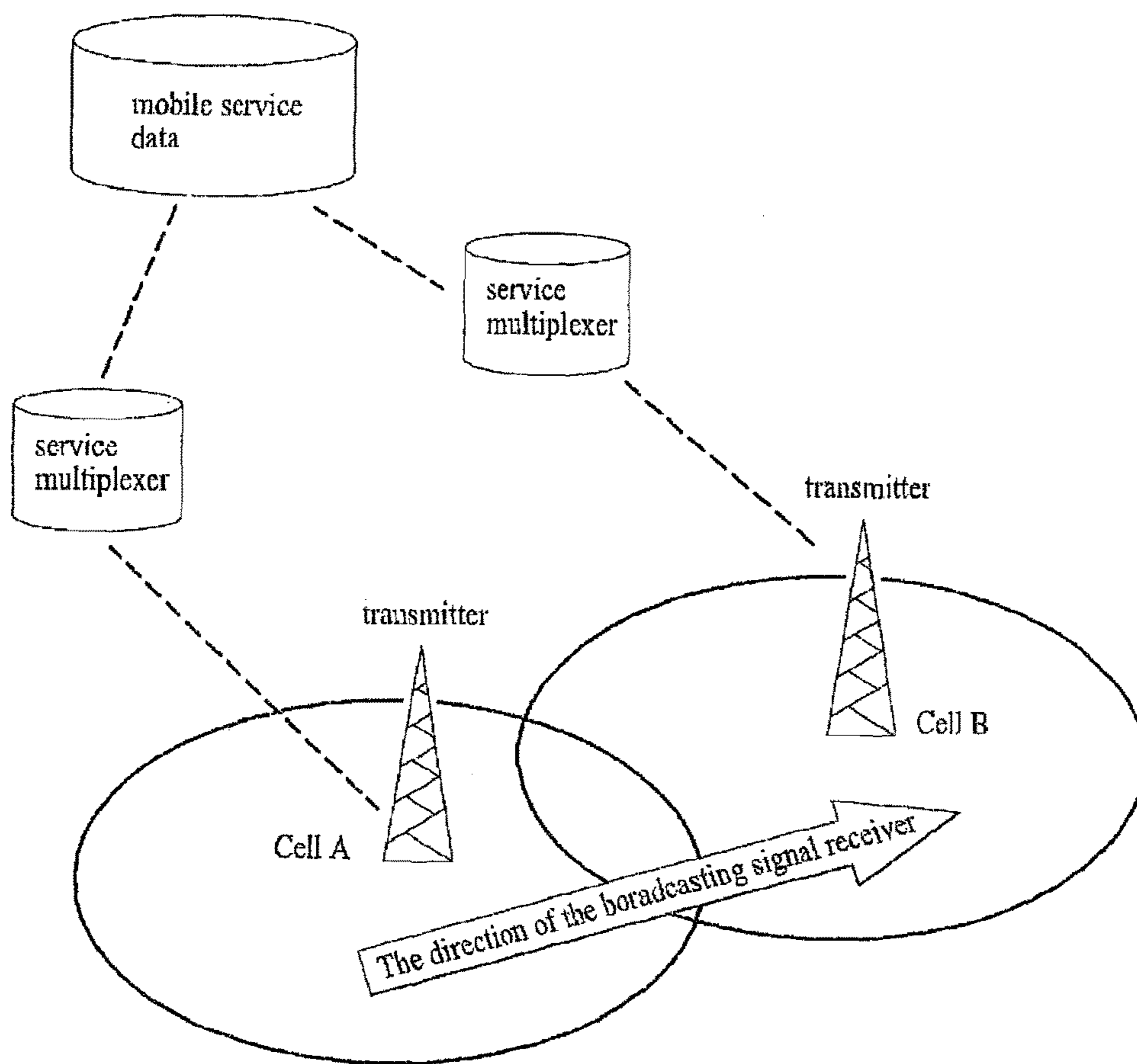

FIG. 6

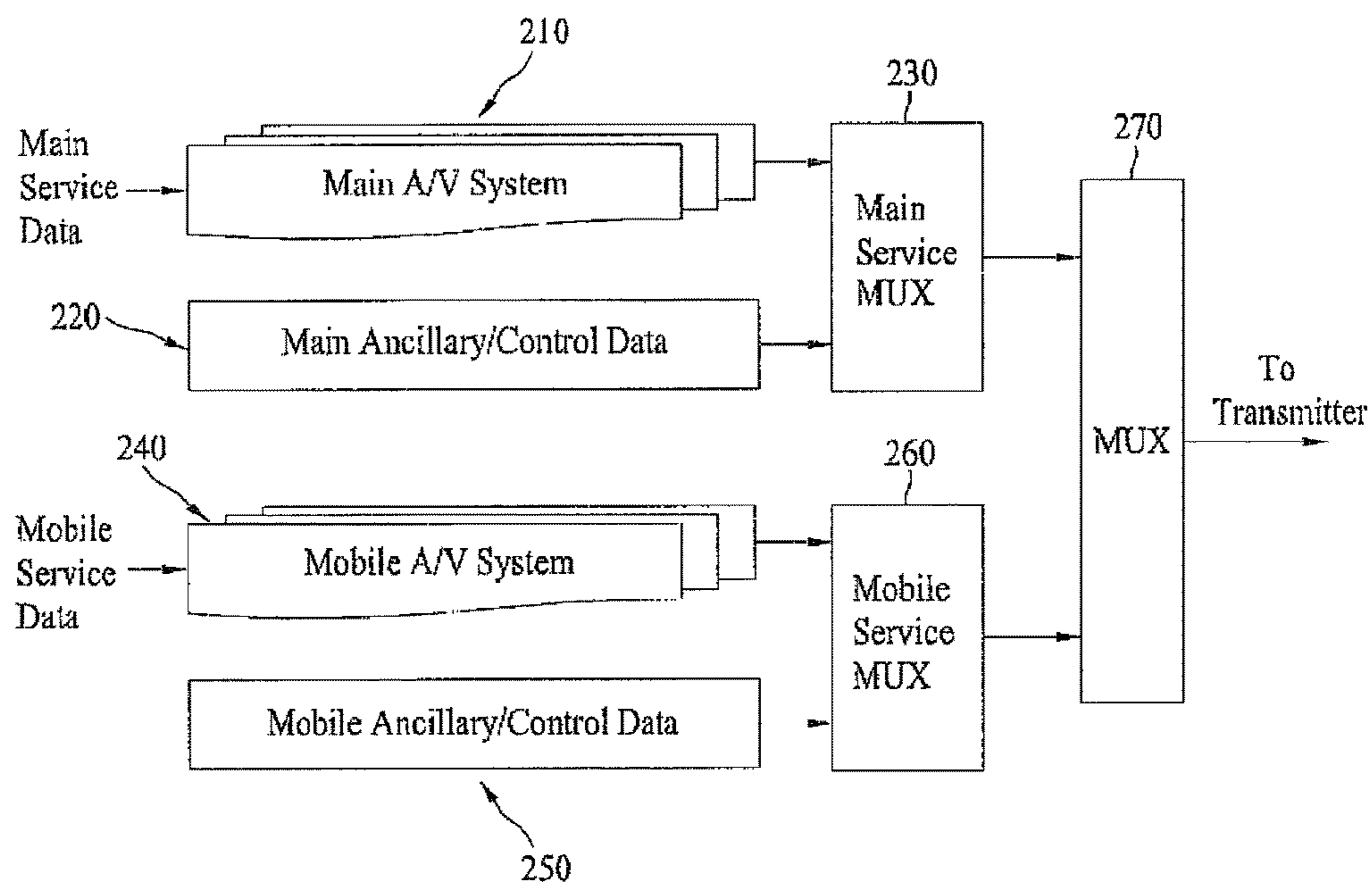

FIG. 7

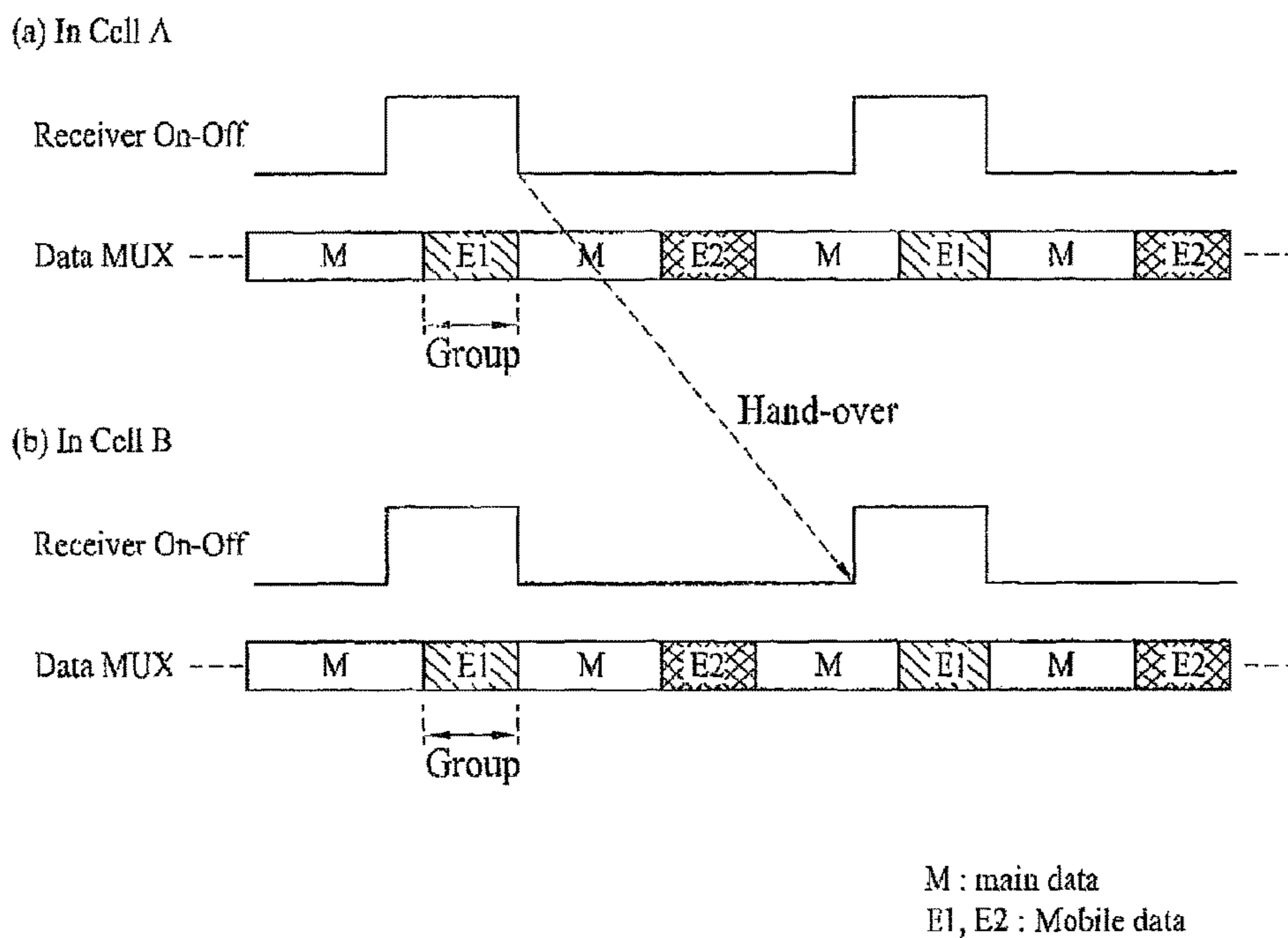

FIG. 8

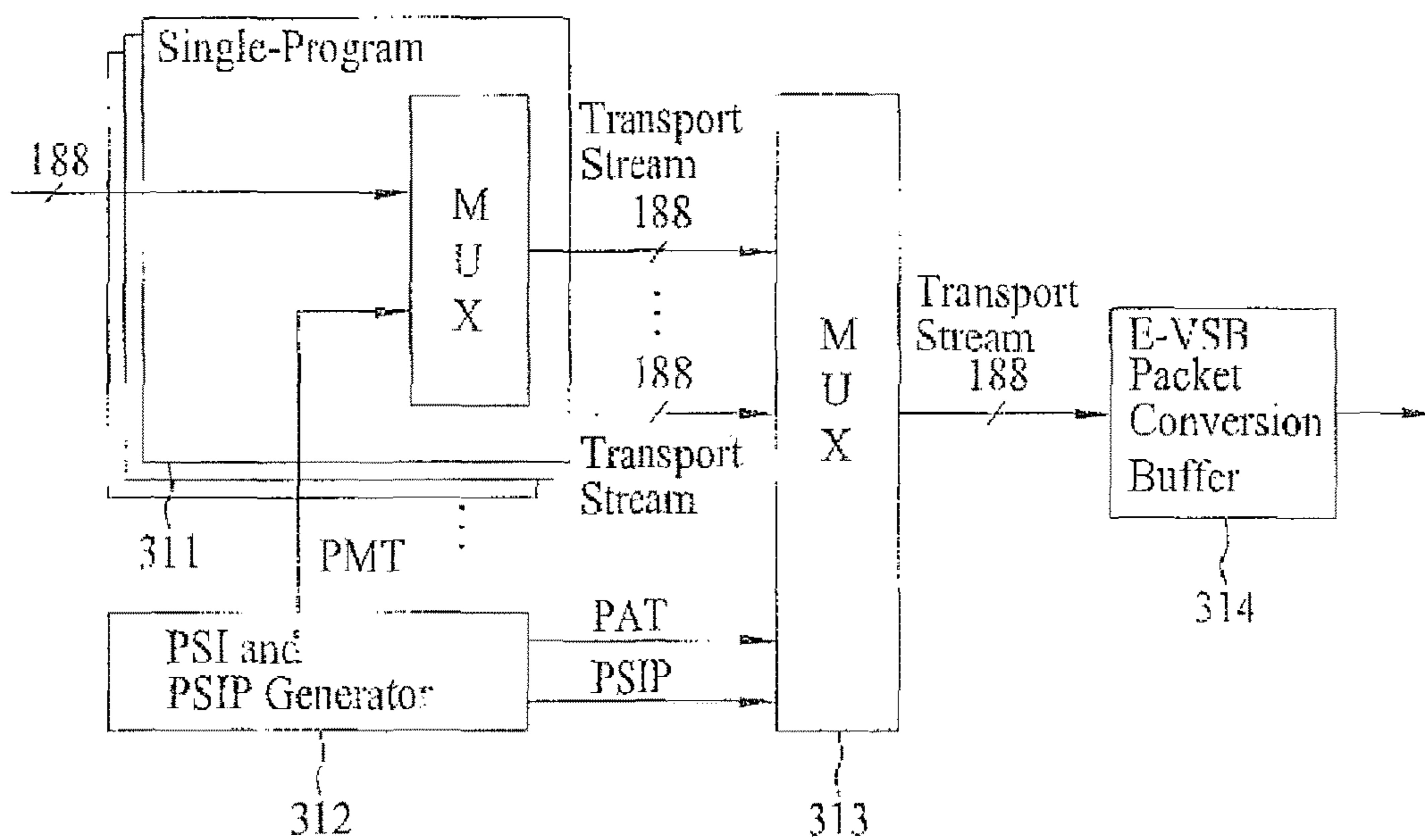

FIG. 9

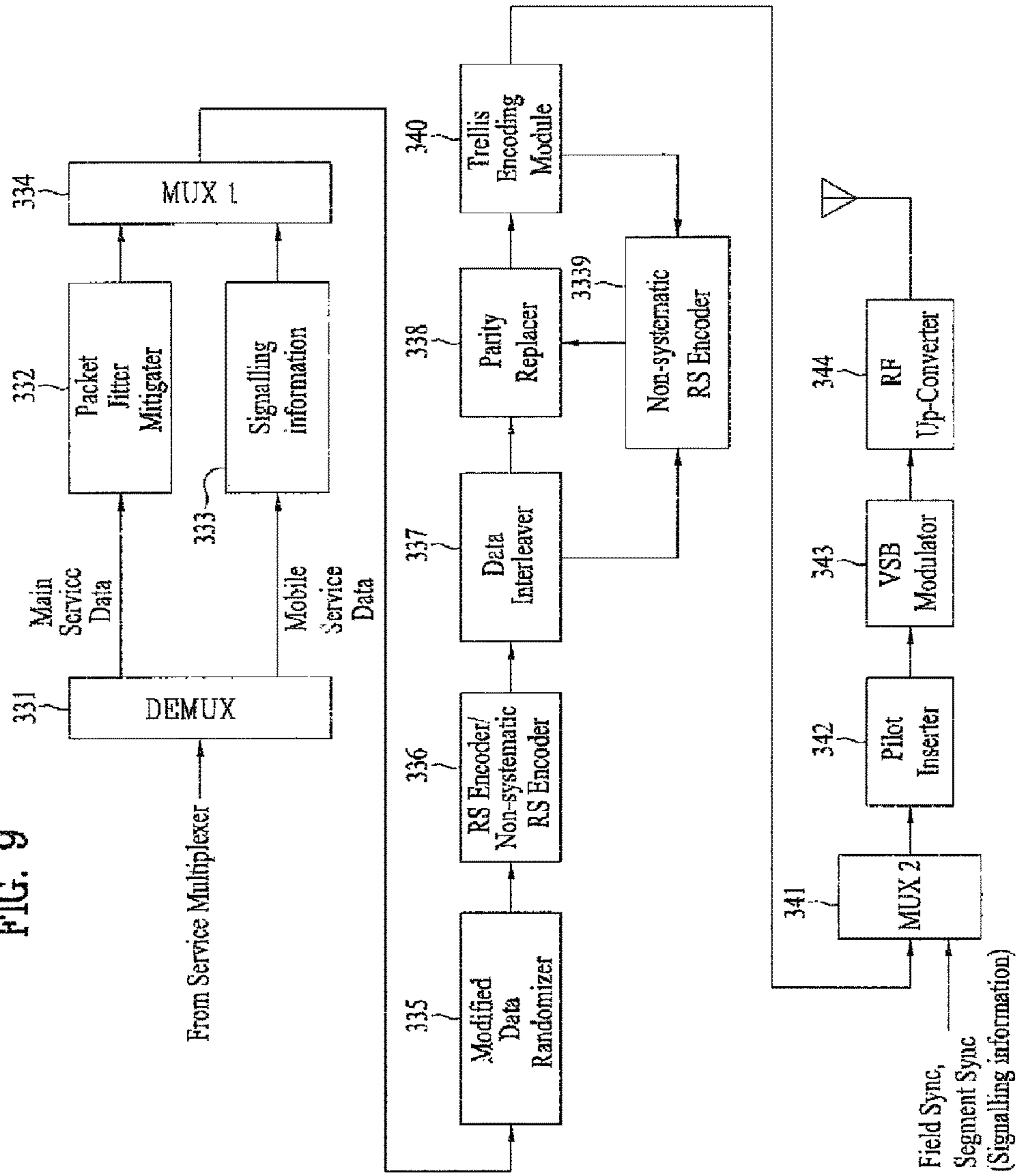

FIG. 10

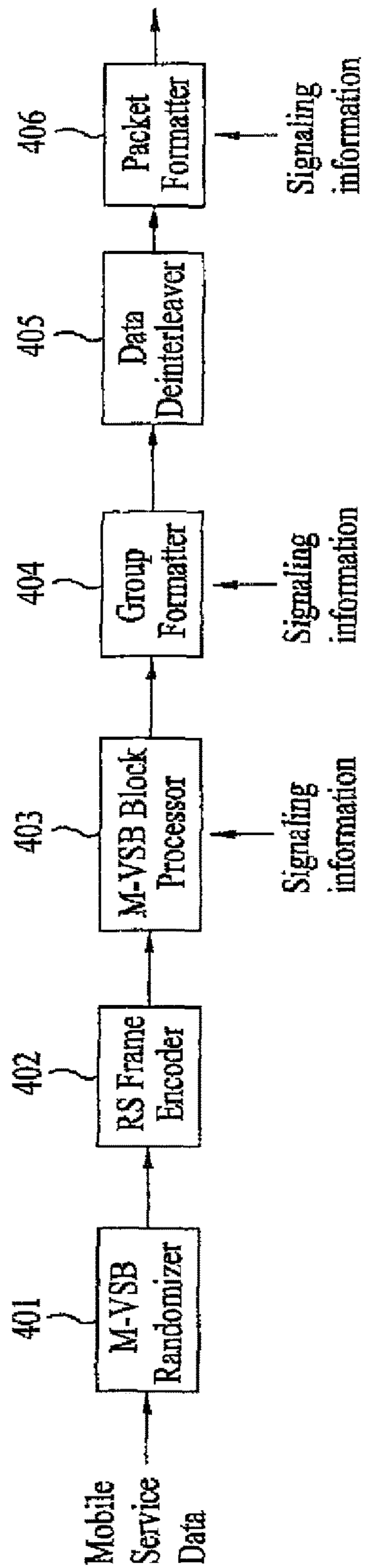

FIG. 11

Value or Range	Meaning	Where Defined
0x0000	Terrestrial Virtual Channel Table (current)	A/65 PSIP
0x0001	Terrestrial Virtual Channel Table (next)	A/65 PSIP
0x0002	Cable Virtual Channel Table (current)	A/65 PSIP
....
0x0021	Network Information Table (MMS Sbutype)	SCTE 65
0x0022	Cell Information Table	A/65 PSIP
0x0023-0x002F	Reserved for future ATSC/SCTE use	
....
0x1280-0xFFFF	Reserved for future ATSC/SCTE use	

FIG. 12

Field Name	Number of Bits	Description and Field Value
cell_information_table_section {		Start of the master_guide_table_section().
table_id	8	0xCE
section_syntax_indicator	1	1b, The CIT uses the MPEG "long-form" syntax.
private_indicator	1	1b, Set to 1 in PSIP tables
reserved	2	11b, Reserved bits are set to 1.
section_length	12	section_length is limited to 1021.
transport_stream_id	16	
reserved	2	11b, Reserved bits are set to 1.
version_number...	5	The version of a table section.
current_next_indicator	1	1b
section_number	8	
last_section_number	8	
protocol_version	8	0, currently defined in s for protocol_version zero.
num_cells_in_section	8	Specifies the num of cells
for(i=0;i<num_cells_in_section;i++) {		
cell_id	8	This 8-bit field acts as the database linkage between the MGT and CIT
cell_text	7*16	Seven Unicode UTF-16 encoded characters, representing the "cell name" of the cell
cell_location	7*16	Seven Unicode UTF-16 encoded characters, representing the "cell location" of the cell
num_channels_in_cell	8	Specifies the channel num of each cell
for(j=0;j<num_channels_in_cell;j++) {		
major_channel_number	10	
minor_channel_number	10	
modulation_mode	8	enumerated type field that indicates the modulation mode
carrier_frequency	32	Specifies carrier frequency
channel_TSID	16	
program_number	16	
reserved	6	
descriptors_length	10	
for(k=0;k<N;k++) {		
descriptor()		
}		
}		
descriptors_length		
for(l=0;l<N;l++) {	10	
descriptor()		
}		
}		
descriptors_length	10	
for(i=0;i<N;i++) {		
descriptor()		
}		
CRC_32	32	A 32-bit checksum error detection code.
}		

FIG. 13

Field Name	Number of Bits	Description and Field Value
master_guide_table_section { table_id	8	Start of the master_guide_table_section(). 0xC7
....
table_id_extension	16	0x0000, Set to zero for the MGT
cell_id	2	index of cell in CIT
version_number	5	
current_next_indicator	1	1b
section_number	8	0, The MGT must fit into a single table section.
....
tables_defined	16	gives the number of table types defined in the MGT
for (i=0; i<tables_defined; i++) {		
table_type	16	defines the type of table
reserved	3	Reserved bits are set to 1.
table_type_PID	13	Specifies the PID that is used to receive table_type
reserved	3	Reserved bits are set to 1.
....
}		
descriptor_length	12	
for (i=0; i<N; i++) {		
descriptor()	var	Zero or more descriptors, formatted
}		
CRC_32	32	A 32-bit checksum value.
}		

FIG. 14

Field Name	Number of Bits	Description and Field Value
Cell_Link_Descriptor { descriptor_tag descriptor_length cell_id reserved }	8 8 2 6	Start of the cell_link_descriptor 0xAB indicates the length, in bytes index of cell in CIT Reserved bits are set to 1.

FIG. 15

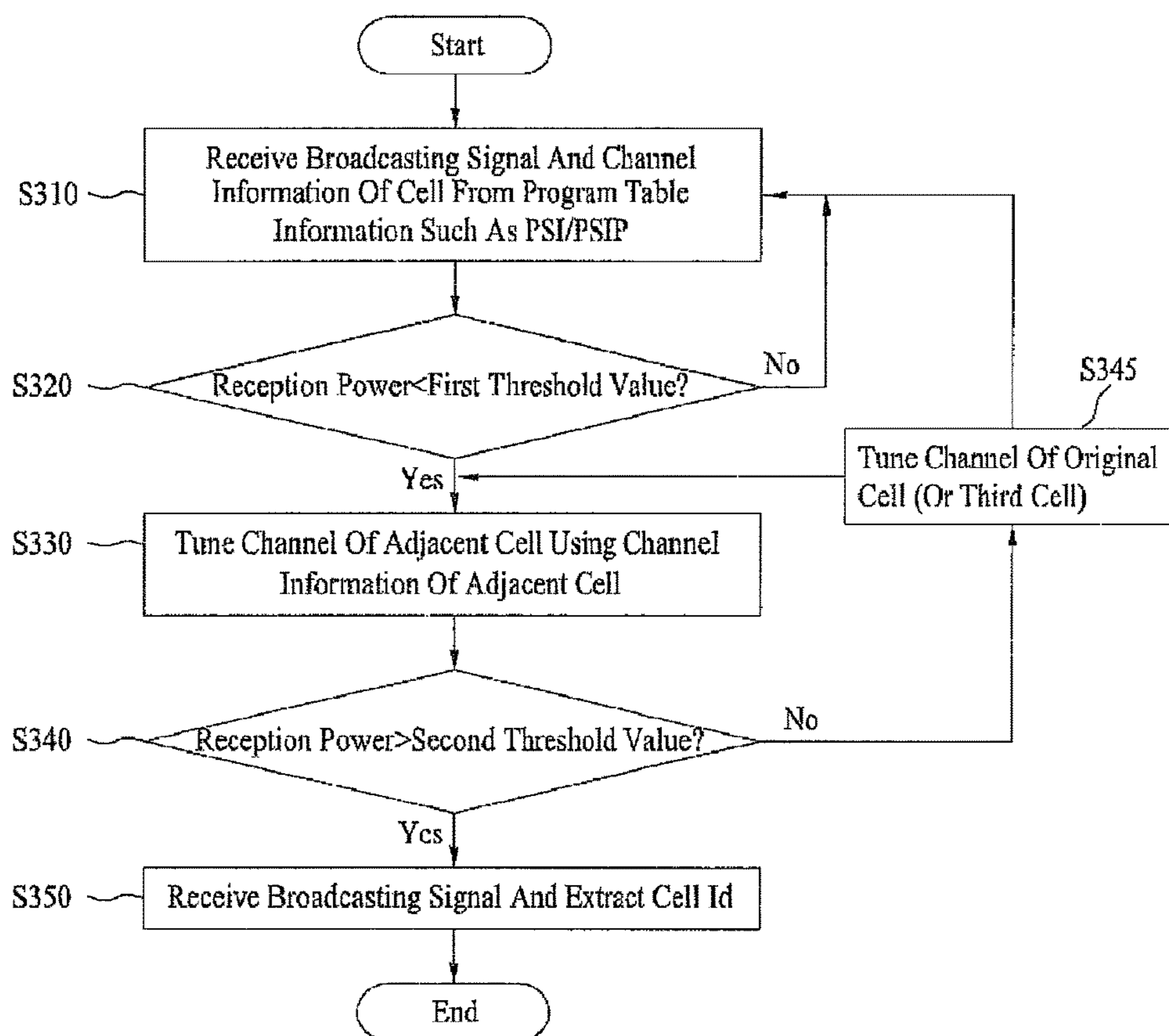

FIG. 16

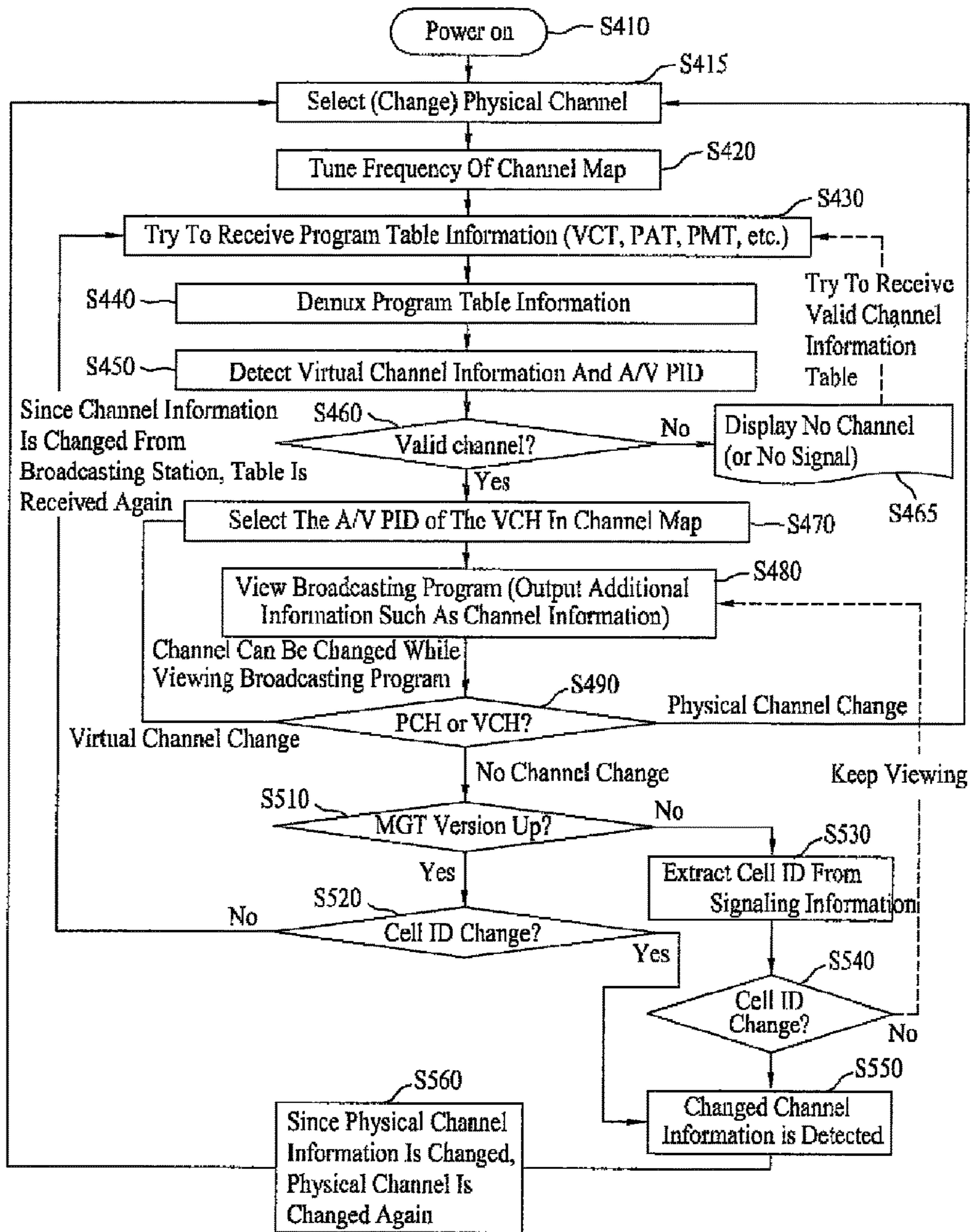

FIG. 17

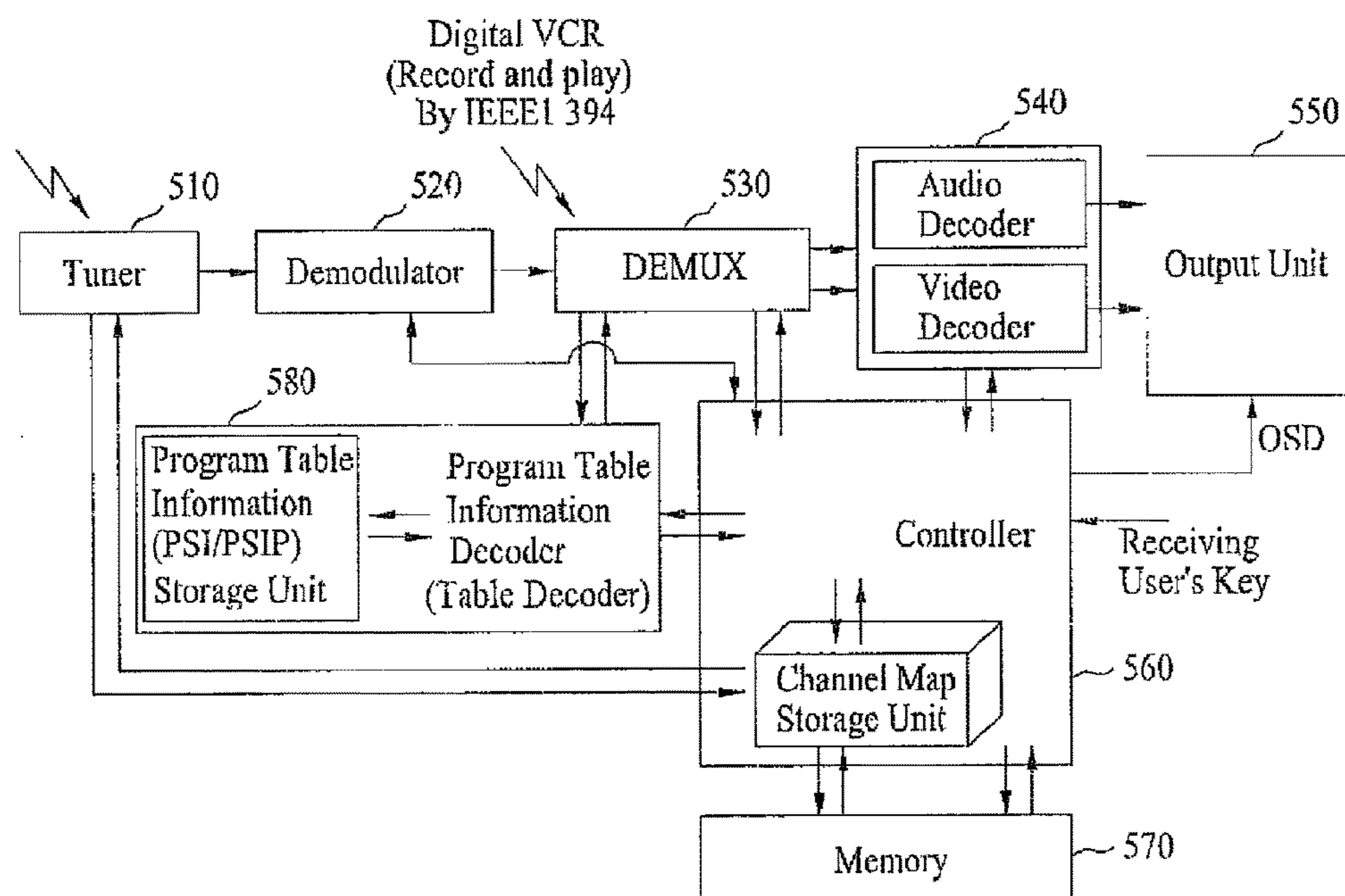

FIG. 18

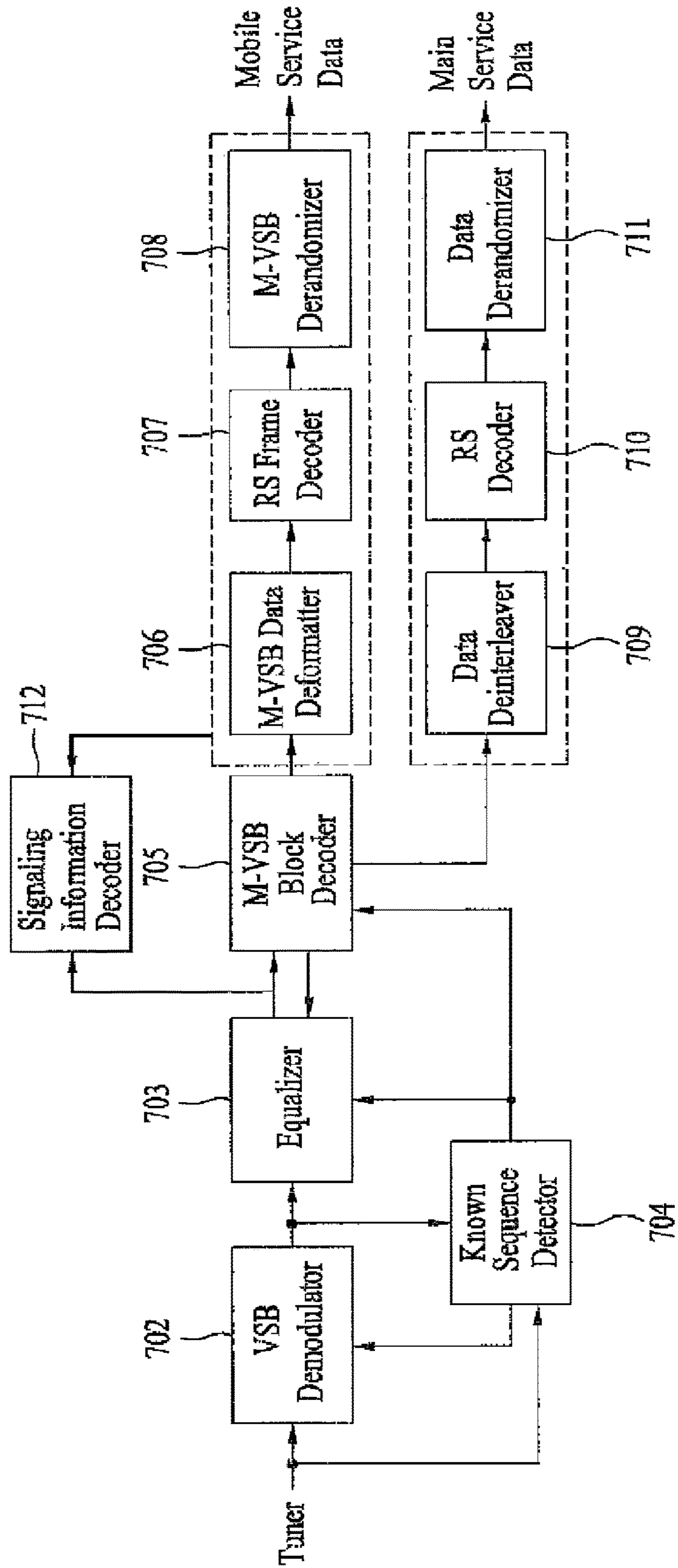

FIG. 19

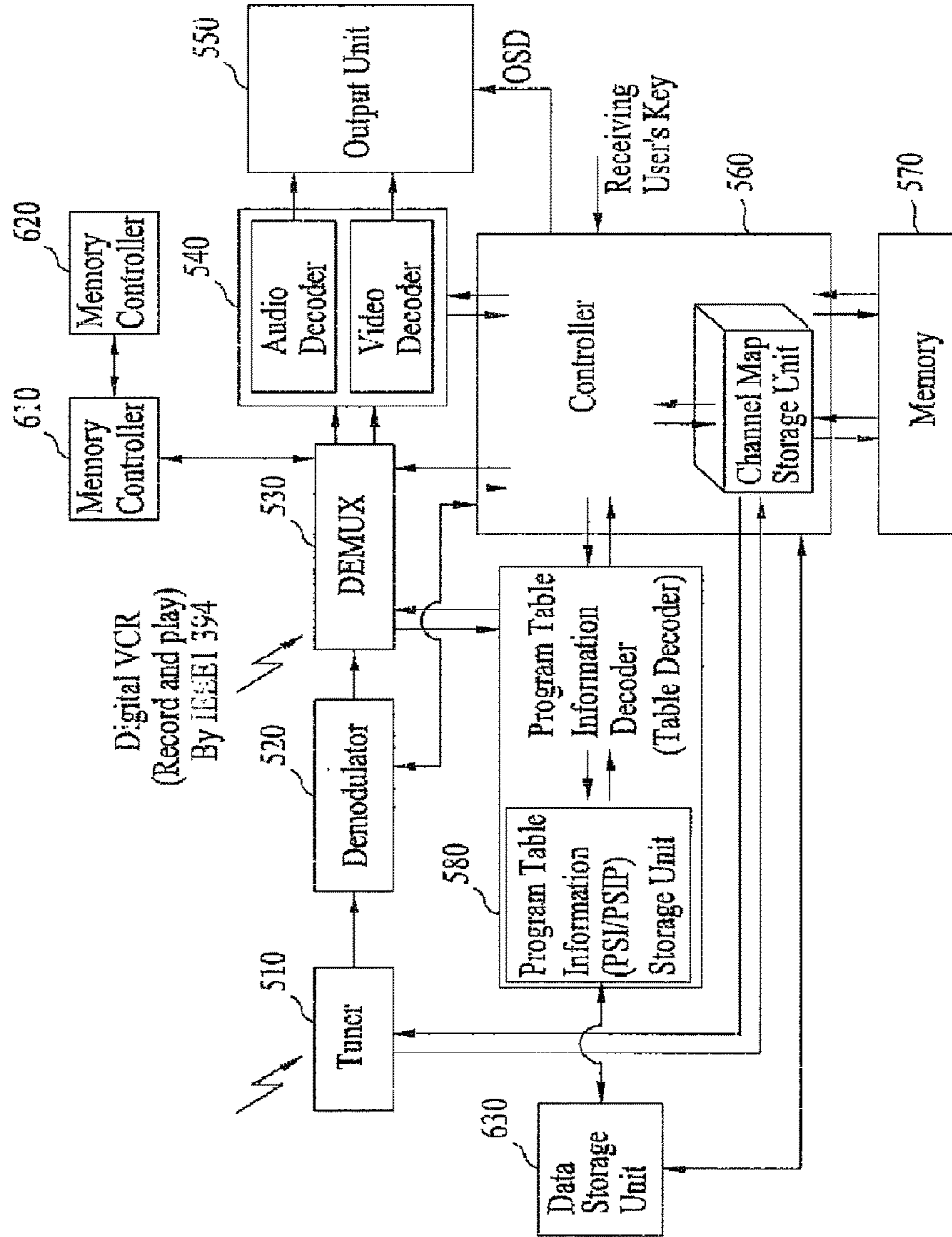

FIG. 20

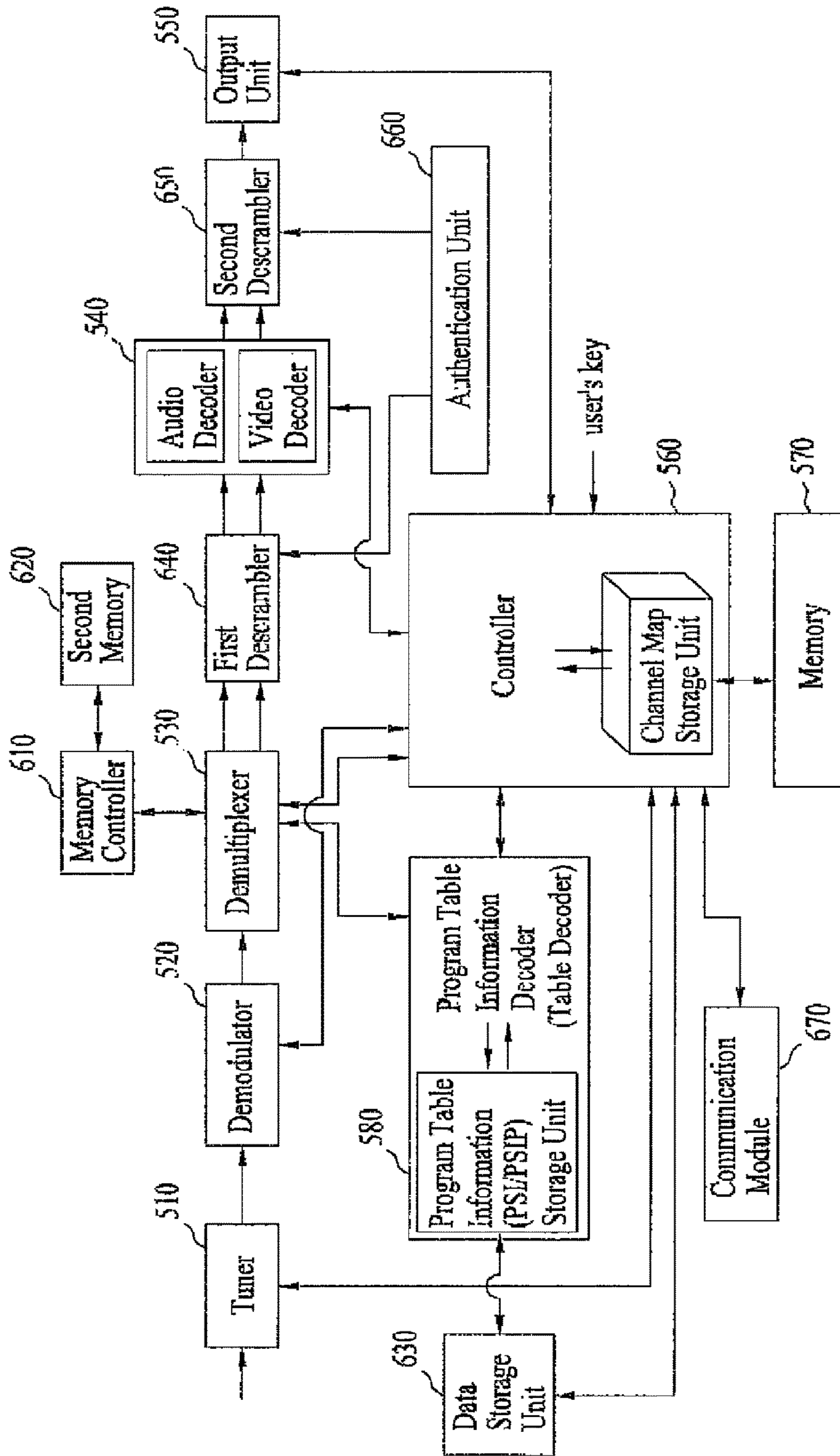
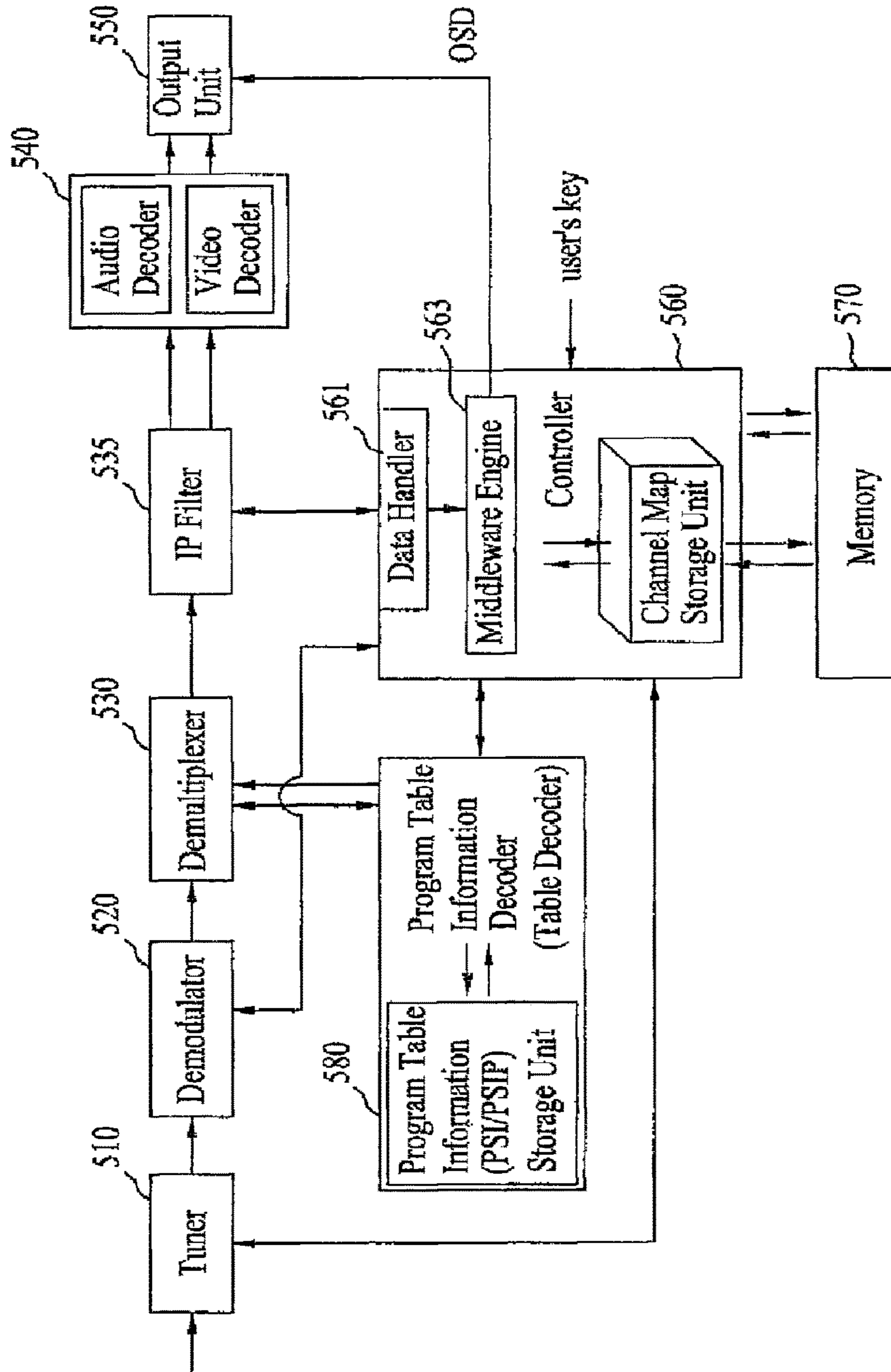

FIG. 21



**BROADCASTING SIGNAL RECEIVER AND
METHOD FOR TRANSMITTING/RECEIVING
BROADCASTING SIGNAL**

Matter enclosed in heavy brackets [] appears in the original patent but forms no part of this reissue specification; matter printed in italics indicates the additions made by reissue; a claim printed with strikethrough indicates that the claim was canceled, disclaimed, or held invalid by a prior post-patent action or proceeding.

This application is a reissue of U.S. Pat. No. 8,392,953, which issued on Mar. 5, 2013, from U.S. application Ser. No. 13/208,239, filed on Aug. 11, 2011, which is a continuation of U.S. application Ser. No. 12/027,801 filed on Feb. 7, 2008, now U.S. Pat. No. 8,023,535, which, pursuant to 35 U.S.C. § 119(a), claims the benefit of earlier filing date and right of priority to Korean Application No. 10-2007-0013929, filed Feb. 9, 2007, and, pursuant to 35 U.S.C. § 120, claims the benefit of U.S. Provisional Application Nos. 60/978,733, filed Oct. 9, 2007, 60/947,984, filed Jul. 4, 2007, and 60/911,808, filed Apr. 13, 2007, the contents of all of which are all hereby incorporated by reference herein in their entirety.

BACKGROUND OF THE INVENTION

1. Field of the Invention

The present invention relates to a broadcasting signal receiver and a method for transmitting/receiving a broadcasting signal.

2. Discussion of the Related Art

A digital broadcasting system for mobile reception, which is capable of transmitting/receiving a broadcasting signal, has been developed and commercialized. However, the digital broadcasting system for mobile reception is designed independent of a broadcasting system for fixed reception and thus is incompatible with the conventional broadcasting system for fixed reception.

For example, a transmission system according to an advanced television systems committee (ATSC) vestigial sideband (VSB) scheme was designed without considering mobility, due to terrestrial characteristics. The ATSC broadcasting system is suitable for a multi-frequency network environment. In the ATSC broadcasting system, if a user moves to an area where broadcasting contents are broadcast with a different frequency, the user should retune a channel in order to continuously view the broadcasting contents.

SUMMARY OF THE INVENTION

Accordingly, the present invention is directed to a broadcasting signal receiver and a method for transmitting/receiving a broadcasting signal that substantially obviate one or more problems due to limitations and disadvantages of the related art.

An object of the present invention is to provide a broadcasting signal receiver and a method for transmitting/receiving a broadcasting signal, of which mobile reception is possible in a multi-frequency network environment.

Another object of the present invention is to provide a broadcasting signal receiver and a method for transmitting/receiving a broadcasting signal in a broadcasting system for mobile reception compatible with a broadcasting system for fixed reception.

Another object of the present invention is to provide a broadcasting signal receiver and a method for transmitting/receiving a broadcasting signal, which are capable of allowing a user to conveniently view a broadcasting program even when the user moves to an area where a broadcasting program is broadcast with a different frequency, in a multi-frequency network environment.

Additional advantages, objects, and features of the invention will be set forth in part in the description which follows and in part will become apparent to those having ordinary skill in the art upon examination of the following or may be learned from practice of the invention. The objectives and other advantages of the invention may be realized and attained by the structure particularly pointed out in the written description and claims hereof as well as the appended drawings.

To achieve these objects and other advantages and in accordance with the purpose of the invention, as embodied and broadly described herein, there is provided a method for transmitting a broadcasting signal, the method including: outputting the broadcasting signal which is obtained by multiplexing first program table information, in which transmission channel information of each cell for broadcasting data identified by a broadcasting stream identifier is configured, second program table information in which an identifier of a cell is configured, and the broadcasting data, modulating the multiplexed broadcasting signal, and transmitting the modulated broadcasting signal.

The second program table information may define a table type of at least one piece of program table information included in the broadcasting signal. The first program table information may include at least one of a major channel number of any channel of each cell, a minor channel number, a modulation mode of the broadcasting signal, a carrier frequency of the broadcasting signal, a channel transport stream identifier and the number of broadcasting programs transmitted through the channel. The first program table information may further include the location of the cell and the name of the cell according to the identifier of the cell.

In another aspect of the present invention, there is provided a method for receiving a broadcasting signal, the method including: receiving the broadcasting signal which is obtained by multiplexing first program table information, in which transmission channel information of each cell for broadcasting data identified by a broadcasting stream identifier is configured, second program table information in which an identifier of a cell is configured, and the broadcasting data, if the identifier of the cell in the second program table information is changed, obtaining channel information for transmitting the broadcasting data in the cell according to the changed identifier, from the first program table information, and tuning the obtained channel information and receiving and outputting the broadcasting data of the changed cell. The second program table information may be a master guide table (MGT). The identifier of the cell may be parsed from a descriptor according to the second program table information.

In another aspect of the present invention, there is provided a method for transmitting a broadcasting signal, the method including: outputting the broadcasting signal which is obtained by multiplexing program table information, in which transmission channel information of each cell for broadcasting data identified by a broadcasting stream identifier is configured, and the broadcasting data; adding a signaling information, in which a transmission parameter including an identifier of a cell is configured, to the output

broadcasting signal and modulating the broadcasting signal; and transmitting the modulated signal.

In another aspect of the present invention, there is provided a method for receiving a broadcasting signal, the method including: receiving the broadcasting signal including program table information, in which transmission channel information of each cell for broadcasting data identified by a broadcasting stream identifier is configured, and an identifier of a first cell, from the first cell; receiving the broadcasting signal from a second cell if the power of the received broadcasting signal is less than a first threshold value; and outputting the broadcasting data using the channel information of the second cell obtained from the program table information of the second cell if the power of the broadcasting signal received from the second cell is greater than a second threshold value and receiving the broadcasting signal from any one of the first cell or a third cell if the power of the broadcasting signal of the second cell is less than the second threshold value.

In another aspect of the present invention, there is provided a broadcasting signal receiver including: a tuner which receives a broadcasting signal including second program table information containing an identifier of a cell and first program table information in which transmission channel information of each cell for broadcasting data identified by a broadcasting stream identifier is configured; a demodulator which demodulates the broadcasting signal received by the tuner; a demultiplexer which demultiplexes the broadcasting signal output from the demodulator; a program table information decoder which decodes the identifier of the cell and the transmission channel information of each cell for the broadcasting data from the program table information output from the demultiplexer; a decoder which decodes the broadcasting signal output from the demultiplexer and outputs a broadcasting program; an output unit which outputs the broadcasting program output from the decoder; and a controller which, if the identifier of the cell decoded by the program table information decoder is changed, obtains channel information of the changed cell from the first program table information and controls the same broadcasting program as the broadcasting program received by the channel of a previous cell to be output from the changed cell.

In another aspect of the present invention, there is provided a broadcasting signal receiver including: a tuner which receives a broadcasting signal including program table information, in which transmission channel information of each cell for broadcasting data identified by a broadcasting stream identifier is configured, and an identifier of a cell; a demodulator which demodulates the broadcasting signal received by the tuner and outputs the identifier of the cell included in the received broadcasting signal and the demodulated broadcasting signal; a demultiplexer which demultiplexes the broadcasting signal output from the demodulator; a program table information decoder which obtains the transmission channel information of each cell for the broadcasting data from the program table information output from the demultiplexer; a decoder which decodes the broadcasting signal output from the demultiplexer and outputs a broadcasting program; an output unit which outputs the broadcasting program output from the decoder; and a controller which, if the cell is changed on the basis of the power of the received broadcasting signal, controls the same broadcasting program as the broadcasting program received by the channel of a previous cell to be output from the changed cell using the channel information obtained from the program table information.

If the cell is changed, the demodulator may demodulate the identifier of the changed cell from signaling information of the signal received from the changed cell.

It is to be understood that both the foregoing general description and the following detailed description of the present invention are exemplary and explanatory and are intended to provide further explanation of the invention as claimed.

BRIEF DESCRIPTION OF THE DRAWINGS

The accompanying drawings, which are included to provide a further understanding of the invention and are incorporated in and constitute a part of this application, illustrate embodiment(s) of the invention and together with the description serve to explain the principle of the invention. In the drawings:

FIG. 1 is a flowchart illustrating a method for transmitting/receiving a broadcasting signal according to an embodiment;

FIG. 2 is a flowchart illustrating a method for transmitting/receiving a broadcasting signal according to another embodiment;

FIG. 3 is a flowchart illustrating a method for transmitting/receiving a broadcasting signal according to another embodiment;

FIG. 4 is a schematic block diagram showing an ATSC broadcasting system in order to easily describe the present invention;

FIG. 5 is a schematic view illustrating the operation of the broadcasting signal receiver;

FIG. 6 is a view showing an example of a service multiplexer shown in FIG. 4;

FIG. 7 is a view illustrating reception of broadcasting data at the time of occurrence of the handover, by the method for transmitting/receiving the broadcasting signal according to the embodiment;

FIG. 8 is a view showing an example of a mobile service multiplexer of the service multiplexer shown in FIG. 6;

FIG. 9 is a block diagram showing an example of a transmitter shown in FIG. 4;

FIG. 10 is a view showing an example of a preprocessor shown in FIG. 9;

FIG. 11 is a view showing table type values defined in a master guide table (MGT) which is program table information having cell information;

FIG. 12 is a view showing a cell information table (CIT) including cell information;

FIG. 13 is a view showing an example of the MGT for describing a method for transmitting/receiving a broadcasting signal according to an embodiment;

FIG. 14 is a view showing an example of a descriptor for describing a method for transmitting/receiving a broadcasting signal according to another embodiment;

FIG. 15 is a flowchart illustrating a method for transmitting/receiving a broadcasting signal according to another embodiment;

FIG. 16 is a flowchart illustrating a method for continuously outputting the same program at the time of occurrence of handover;

FIG. 17 is a view showing a broadcasting signal receiver according to an embodiment;

FIG. 18 is a view showing an example of a demodulator in the broadcasting signal receiver;

FIG. 19 is a view showing a broadcasting signal receiver according to another embodiment;

5

FIG. 20 is a view showing a broadcasting signal receiver according to another embodiment; and

FIG. 21 is a view showing a broadcasting signal receiver according to another embodiment.

DETAILED DESCRIPTION OF THE
INVENTION

Reference will now be made in detail to the preferred embodiments of the present invention, examples of which are illustrated in the accompanying drawings. Wherever possible, the same reference numbers will be used throughout the drawings to refer to the same or like parts.

Hereinafter, exemplary embodiments of the present invention will be described with reference to the accompanying drawings.

FIG. 1 is a flowchart illustrating a method for transmitting/receiving a broadcasting signal according to an embodiment. Hereinafter, the method for transmitting/receiving the broadcasting signal according to the present embodiment will be described with reference to FIG. 1.

A broadcasting transmitter side outputs a broadcasting signal which is obtained by multiplexing program table information including an identifier of a cell, which is a propagation area of the broadcasting signal, and broadcasting data and modulating the multiplexed signal (S10). The program table information will be described in detail later.

The broadcasting signal including the identifier of the cell is transmitted (S20).

A broadcasting receiver side receives the broadcasting signal including the identifier of the cell which is the propagation area of the broadcasting signal (S30).

The received broadcasting signal is demodulated and the program table information is parsed from the demodulated signal so as to obtain the identifier of the cell (S40).

In the present embodiment, particularly, in the case where the broadcasting receiver receives the broadcasting signal while moving in the multi-frequency network (MFN) environment, the propagation area of the broadcasting signal transmitted with any one of multiple frequencies can be identified.

FIG. 2 is a flowchart illustrating a method for transmitting/receiving a broadcasting signal according to another embodiment. Hereinafter, the method for transmitting/receiving the broadcasting signal according to the present embodiment will be described with reference to FIG. 2.

A broadcasting transmitter side outputs a broadcasting signal which is obtained by multiplexing program table information, in which transmission channel information of each cell for broadcasting data identified by a broadcasting stream identifier is configured, program table information, in which an identifier of a cell is configured, and the broadcasting data (S110).

Then, the multiplexed broadcasting signal is modulated (S120) and the modulated broadcasting signal is transmitted (S130).

When the broadcasting signal is received, a receiver side receives the broadcasting signal which is obtained by multiplexing first program table information, in which the transmission channel information of each cell for the broadcasting data identified by the broadcasting stream identifier is configured, second program table information, in which the identifier of the cell is configured, and the broadcasting data (S140).

The first program table information may include information indicating through which channel of another cell the broadcasting program transmitted by any broadcasting sta-

6

tion of a first cell is transmitted. The first program table information may deliver channel information of the broadcasting data according to the broadcasting stream identifier.

If the identifier of the cell in the second program table information is changed, the channel information for transmitting the broadcasting data in the cell according to the changed identifier is obtained from the first program table information (S150).

The obtained channel information is tuned and the broadcasting data of the changed cell is received and output (S160).

FIG. 3 is a flowchart illustrating a method for transmitting/receiving a broadcasting signal according to another embodiment. Hereinafter, the method for transmitting/receiving the broadcasting signal according to the present embodiment will be described with reference to FIG. 3.

A broadcasting transmitter side outputs a broadcasting stream which is obtained by multiplexing program table information, in which transmission channel information of each cell for broadcasting data identified by a broadcasting stream identifier is configured, and the broadcasting data (S210).

Signaling information, in which a transmission parameter including an identifier of a cell is configured, is added to the output broadcasting signal and the broadcasting signal is modulated (S220).

The modulated signal is transmitted (S230).

A broadcasting receiver side receives the broadcasting signal including the program channel information, in which the transmission channel information of each cell for the broadcasting data identified by the broadcasting stream identifier is configured, and the identifier of a first cell (S240).

If the power of the received broadcasting signal is less than a first threshold value, a signal transmitted from a second cell is received and an identifier of the second cell configured in the signaling information of the signal received from the second cell is obtained (S250).

The channel of the second cell for the broadcasting data is tuned using the program table information and the broadcasting signal is received from the tuned channel and is output (S260).

In order to easily describe the present invention, for example, an ATSC broadcasting system suitable for the MFN environment will be described, but the present invention is not limited thereto.

FIG. 4 is a schematic block diagram showing the ATSC broadcasting system in order to easily describe the present invention.

In the ATSC broadcasting system, a device for transmitting a broadcasting signal includes a service multiplexer and a transmitter.

Here, the service multiplexer may be located at a studio of each broadcasting station and the transmitter may be located at one or more specific sites. A plurality of transmitters may share the same frequency. In this case, the plurality of transmitters transmits the same signal. The service multiplexer multiplexes main service data for fixed reception and mobile service data for mobile reception. The transmitter modulates the multiplexed broadcasting data and transmits the modulated broadcasting data. Hereinafter, for convenience of description, a method for modulating the main service data for fixed reception and the mobile service data for mobile reception is called a mobile VSB (MVSB). If the broadcasting data for mobile reception is transmitted, the transmitter modulates the mobile service data for mobile

reception such that the data can be stably received, regardless of various distortions or noise which may occur in a transmission channel.

A broadcasting signal receiver can compensate for the signal distortions and restore the broadcasting signal. Data communication between the service multiplexer and the transmitter, both of which are separated from each other, may be performed by various methods. For example, the standard such as synchronous serial interface for transport of MPEG-2 data (SMPTE-310M) may be used.

FIG. 5 is a schematic view illustrating the operation of the broadcasting signal receiver. For convenience of description, hereinafter, a range which is influenced by a transmission system according to one frequency in the MFN environment is called a cell. According to the present embodiment, even when the broadcasting signal receiver receives the broadcasting signal while moving over several cells, a viewer can continuously view the broadcasting program of the channel which has been received. The broadcasting signal receiver can receive the broadcasting signal from a current cell A and then receive the broadcasting signal from another cell B, that is, can change a cell for receiving the broadcasting signal. Hereinafter, this is called handover.

A mobile service elementary stream (ES) for mobile reception may be transmitted through transmitters with different area-based frequencies. If the mobile service ES for mobile reception is transmitted, the cell from which the broadcasting signal receiver receives the broadcasting signal and the physical information of the channel of the cell are changed. However, although the user does not perform an additional operation such as the tuning of the channel, the broadcasting signal of the same channel may be output. The cell can be identified by a cell ID. In each cell, any ES may be transmitted through different physical channels.

Table 1 shows the broadcasting information and the locations of the transmitters according to the cell ID.

TABLE 1

Cell ID	0x0001	0x0002
Location	Mt. Gwanak	Mt. Yongmoon
Broadcasting information:	MBC (11, 15)	MBC (11, 14)
channel name	ABC1 (9, 14)	ABC1 (9, 21)
(major, physical)	ABC2 (7, 13)	ABC2 (7, 22)
	SBB (6, 16)	SBB (6, 12)
	ESS (10, 29)	ESS (10, 25)

In the example of Table 1, a cell having a cell ID of 0x0001 is located at Mt. Gwanak and a cell having a cell ID of 0x0002 is located at Mt. Yongmoon. The same broadcasting signal can be transmitted through different physical channels according to the cell.

FIG. 6 is a view showing an example of the service multiplexer shown in FIG. 4 in the broadcasting signal receiver according to the embodiment. The service multiplexer shown in FIG. 6 includes a main audio/video (A/V) system 210, main ancillary/control data system 220, a mobile A/V system 240, a mobile ancillary/control data system 250, a main service multiplexer 230, a mobile service multiplexer 260 and a transmission service multiplexer 270.

Main service data is encoded and compressed by the main A/V system 210 and is output to the main service multiplexer 230. If the number of types of main service data is greater than one, a plurality of main A/V systems may be included. The main service multiplexer 230 multiplexes the

output of the main A/V system 210 and various types of additional data 220 of the main service and outputs the multiplexed data to the transmission service multiplexer 270.

Similarly, mobile service data is encoded and compressed by the mobile A/V system 240 and is output to the mobile service multiplexer 260. If the number of types of mobile service data is greater than one, a plurality of mobile A/V systems may be included. The mobile service multiplexer 260 multiplexes the output of the mobile A/V system 240 and various types of additional data of the mobile service and outputs the multiplexed data to the transmission service multiplexer 270.

The transmission service multiplexer 270 multiplexes the output of the main service multiplexer 230 and the output of the mobile service multiplexer 260 and outputs the multiplexed data to the transmitter. The output data of the transmission service multiplexer 270 may be expressed in the form of an MPEG-2 transport stream (TS) packet.

The transmission service multiplexer 270 can transmit the service data to the transmitter at a constant data rate. The transmission service multiplexer 270 can transmit the service data to the transmitter at a constant data rate even when the service data transmitted to the transmitter includes only the main service data or both the main service data and the mobile service data. For example, if the transmission service multiplexer 270 transmits the data to the transmitter at 19.39 Mbps, the mobile service data is multiplexed with the main service data and is transmitted within 19.39 Mbps. The mobile service data may be subjected to be error correction coding process in the transmitter and thus the data rate of the mobile service data may be reduced in consideration of the error correction encoding process.

If the output of the service multiplexer needs to be maintained at the constant data rate, for example, 19.39 Mbps, at least one of the main service multiplexer, the mobile service multiplexer and the transmission data multiplexer may insert null data or null packet in the multiplexed data so as to match the data rate of the final output to the constant data rate. Here, the null data may be generated in the multiplexer or may be received from an external device.

FIG. 7 is a view illustrating reception of broadcasting data at the time of occurrence of the handover, by the method for transmitting/receiving the broadcasting signal according to the embodiment. Transmission data obtained by multiplexing the main service data M and mobile service data E1 and E2 may be transmitted to each cell. The main service data and the mobile service data may be multiplexed on a time axis and may be transmitted in the form of a burst, and desired broadcasting service data can be obtained by turning on/off the receiver only in a time period when the desired broadcasting service data is transmitted. For example, if broadcasting data E1 is obtained in the cell A, the signal is received only in a time period when the broadcasting data E1 is transmitted. In time periods when the main service data and the broadcasting data E2 are received, the power of the receiving unit of the broadcasting signal receiver is turned off. In the case where the broadcasting signal receiver is turned on/off in order to receive the signal, the broadcasting signal receiver is turned on/off earlier than an actual reception period such that a tuner or a demodulator prepares for the signal reception. Even when the broadcasting signal receiver receives the broadcasting data E1 in the cell B, the similar operation with that of the cell A may be performed.

In the case where the broadcasting signal receiver receives the broadcasting data E1 while moving over a plurality of cells, the broadcasting signal receiver can con-

tinuously receive the same broadcasting data (for example, E1) although the handover occurs in the broadcasting signal receiver.

FIG. 8 is a view showing an example of a mobile service multiplexer of the service multiplexer shown in FIG. 6. The mobile service multiplexer shown in FIG. 8 includes a first multiplexer 311, a program table information generator 312, a second multiplexer 313 and a packet conversion buffer 314.

The first multiplexer 311 multiplexes mobile data of an MPEG-2 TS format and program table information, such as a program map table (PMT), generated by the program table information generator 312 and outputs the multiplexed data to the second multiplexer 313. The program table information generator 312 generates information according to program specific information (PSI) or program and system information protocol (PSIP). The PSI includes information such as the PMT and a program association table (PAT), and the PSIP includes a system time table (STT), a rating region table (RRT), a master guide table (MGT), a virtual channel table (VCT), an event information table (EIT) and an extended text table (ETT). Hereinafter, the information on the broadcasting signal which is transmitted in the form of at least one section, such as the PSI/PSIP, is called the program table information. The program table information generator 312 can generate the program table information for delivering information on the channel of each cell. Hereinafter, the program table information including the cell information such as the channel information of the cell is called a cell information table (CIT).

Each broadcasting station may allocate the information on the cell, which is an area of a signal transmitted by the broadcasting station, to the CIT and transmit the CIT. Since the CIT can transmit the channel information according to the cell divided by the broadcasting station for allocating the CIT, the broadcasting stations may transmit CITs having different contents.

The second multiplexer 313 multiplexes the output of the first multiplexer 311 and the output of the program table information generator 312 and outputs the multiplexed signal to the packet conversion buffer 314. The first multiplexer 311 includes a plurality of multiplexers for multiplexing plural pieces of mobile service data and the PMT of the data. Here, one mobile service data may become a single program. Information on a physical layer for real-time broadcasting, that is, information such as time slicing of a transmission signal and a burst length, may be included in the program table information. The packet conversion buffer 314 adjusts 188-byte transport stream output from the second multiplexer 313 to a block length required in a preprocessor which will be described later.

FIG. 9 is a block diagram showing an example of the transmitter shown in FIG. 4.

The transmitter includes a demultiplexer 331, a packet jitter mitigator 332, an M-VSB preprocessor 333, a first transmission data multiplexer 334, a data randomizer 335, an RS encoder/non-systematic RS encoder 336, a data interleaver 337, a parity replacer 338, a non-systematic RS encoder 339, a trellis encoding module 340, a second transmission data multiplexer 341, a pilot inserter 342, a VSB modulator 343, and an RF up-converter 344.

The demultiplexer 331 of the transmitter demultiplexes the data received from the transmission service multiplexer 270, divides the data into the main service data and the mobile service data, outputs the divided main service data to the packet jitter mitigator 332, and outputs the mobile service data to the M-VSB preprocessor 333.

If the transmission service multiplexer 270 inserts the null data into the data and then transmits the data in order to match the data rate to the constant data rate, the demultiplexer 331 discards the null data by referring to the identifier which is transmitted together, processes only the remaining data, and outputs the processed data to a corresponding block. The demultiplexer 331 may configure other information, such as control information necessary for transmission in the null data, and transmit the null data.

The M-VSB preprocessor 333 performs an additional encoding process with respect to the mobile service data in order to rapidly cope with noise and a channel variation. The mobile service data divided by the demultiplexer 331 is output to the M-VSB preprocessor 333. The M-VSB preprocessor 333 may randomize the mobile service data and perform an error correction coding process. If the M-VSB preprocessor 333 performs the randomizing process, the data randomizer 335 of the next stage may omit the randomizing process of the mobile service data. The randomizer of the mobile service data may be equal to or different from a randomizer defined in the ATSC.

The main service data packet and the mobile service data packet based on 188-byte units in data of a predetermined format output from the M-VSB preprocessor 333 are multiplexed according to a predefined multiplexing method and are output to the data randomizer 335. The multiplexing method can be adjusted by various variables of the system design.

In the method for multiplexing the data by the first transmission data multiplexer 334, as shown in FIG. 7, a burst period is provided on the time axis, a plurality of data groups may be transmitted in the burst period and only the main service data may be transmitted in a non-burst period. In contrast, the main service data may be transmitted in the burst period. That is, as shown in FIG. 7, a plurality of successive mobile service packets forms one data group and the plurality of data groups is mixed with the main service data packets so as to form one burst. The mobile service data or the main service data may be transmitted in one burst period.

The main service data may exist in the burst period or the non-burst period. The numbers of main data packets in the main service data period of the burst period and the main service data period of the non-burst period may be different from or equal to each other.

If the mobile service data is transmitted in the burst structure, the broadcasting signal receiver for receiving only the mobile service data is turned on only in the burst period so as to receive the data and is turned off in the period in which only the main service data is transmitted, thereby reducing the power consumption of the receiver.

The packet jitter mitigator 332 readjusts a relative location of the main service data packet such that overflow or underflow does not occur in the buffer of the decoder in the broadcasting signal receiver. Since the mobile service data group is multiplexed with the main service data in the packet multiplexing process, the temporal location of the main service packet is relatively changed. The decoder (for example, the MPEG decoder) of the device for processing the main service data of the broadcasting signal receiver may receive and decode only the main service data, recognize the mobile service data packet as the null packet, and discard the mobile service data packet. Accordingly, when the decoder of the broadcasting signal receiver receives the main service data packet multiplexed with the mobile service data group, packet jitter may occur.

Since the decoder of the receiver includes multi-stage buffers for video data and has a large size, the first transmission data multiplexer **334** may generate the packet jitter. Due to the packet jitter, overflow or underflow may occur in the buffer for the main service data of the broadcasting signal receiver, for example, the buffer for audio data.

The packet jitter mitigator **332** knows the multiplexing information of the first transmission data multiplexer **334**. If it is assumed that the audio data packets are normally processed, the packet jitter mitigator **332** may rearrange the audio data packets of the main service as follows.

First, if one audio data packet is included in the main service data period of the burst period, for example, in the main service data period interposed between two mobile service data groups, the audio data packet is arranged at a foremost location of the main service data period, if two audio data packets are included in the main service data period of the burst period, the audio data packets are arranged at foremost and hindmost locations of the main service data period, and if at least three audio data packets are included in the main service data period of the burst period, two audio data packets are arranged at the foremost and hindmost locations of the main service data period and the remaining audio data packet is arranged therebetween at a uniform interval. Second, the audio data packet is arranged at a hindmost location in the main service data period before the start of the burst period. Third, the audio data packet is arranged at a foremost location in the main service data period after the completion of the burst period. The packets other than the audio data are arranged in a period excluding the locations of the audio data packets in input order.

If the locations of the main service data packets are relatively readjusted, a program clock reference (PCR) value is corrected. The PCR value is a time reference value for setting the time of the MPEG decoder, which is inserted into a specific area of a TS packet and is transmitted. The packet jitter mitigator **332** may correct the PCR value.

The output of the packet jitter mitigator **332** is input to the first transmission data multiplexer **334**. The first multiplexer **334** multiplexes the main service data output from the packet jitter mitigator **332** and the mobile service data output from the M-VSB preprocessor **333** to the burst structure according to the predefined multiplexing rule and outputs the burst structure to the data randomizer **335**.

The data randomizer **335** performs the same randomizing process as the existing randomizer if the received data is the main service data packet. That is a sync byte in the main service data packet is discarded and the remaining 187 bytes are randomized using a pseudo random byte generated therein and are output to the RS encoder/non-systematic RS encoder **336**.

However, if the received data is the mobile service data packet, the data randomizer **335** may discard the sync byte of 4-byte MPEG header included in the mobile service data packet and randomize the remaining 3 bytes. The remaining mobile service data excluding the MPEG header is output to the RS encoder/non-systematic RS encoder **336**, without being randomized. In this case, the randomizing process is previously performed by the M-VSB preprocessor **333**. Known data (or a known data location holder) included in the mobile service data packet and an initialization data location holder may be randomized or may not be randomized.

The RS encoder/non-systematic RS encoder **336** performs RS encoding process with respect to the data randomized by the data randomizer **335** or bypassed data so as to add a 20-byte RS parity and then outputs the encoded data to the data interleaver **337**. At this time, if the received data is the

main service data packet, the RS encoder/non-systematic RS encoder **336** performs a systematic RS encoding process so as to add the 20-byte RS parity to the back of the 187-byte data, similar to an ATSC VSB system. If the received data is the mobile service data packet, the 20-byte RS parity obtained by performing the non-systematic RS encoding process is inserted at the parity byte location decided in the packet.

The data interleaver **337** performs a convolutional interleaving process in the unit of bytes. The output of the data interleaver **337** is input to the parity replacer **338** and the non-systematic RS encoder **339**.

The memory of the trellis encoding module **340** may be first initialized such that output data of the trellis encoding module **340** located at the next stage of the parity replacer **338** is set to known data defined by the agreement between the transmitter and the receiver. The memory of the trellis encoding module **340** is first initialized before the received known data sequence is trellis-encoded.

If a start part of the received known data sequence is the initialization data location holder inserted by the M-VSB preprocessor **333**, initialization data is generated and is replaced with the trellis memory initialization data location holder immediately before the received known data sequence is trellis-encoded.

The value of the trellis memory initialization data is decided and generated according to the memory status of the trellis encoding module **340**. Due to the influence of the replaced initialization data, the RS parity may be calculated again and may be replaced with the RS parity output from the data interleaver **337**.

The non-systematic RS encoder **339** receives the mobile service data packet including the initialization data location holder, which will be replaced with the initialization data, from the data interleaver **337** and receives the initialization data from the trellis encoding module **340**. The initialization data location holder of the received mobile service data packet is replaced with the initialization data, the RS parity data added to the mobile service data packet is removed, and a new non-systematic RS parity is calculated and is output to the parity replacer **338**. Then, the parity replacer **338** selects the output of the data interleaver **337** with respect to the data in the mobile service data packet, selects the output of the non-systematic RS encoder **339** with respect to the RS parity, and outputs the selected data to the trellis encoding unit **340**.

If the main service data packet is received or if the mobile service data packet no including the initialization data location holder to be replaced is received, the parity replacer **338** selects and outputs the RS parity and the data output from the data interleaver **337** to the trellis encoding module **340** without alteration.

The trellis encoding module **340** converts the data based on byte units into the data based on symbol units, performs 12-way interleaving, performs the trellis encoding process, and outputs the encoded data to the second transmission data multiplexer **341**.

The second transmission data multiplexer **341** inserts a field sync signal and a segment sync signal to the output of the trellis encoding module **340** and outputs the inserted data to the pilot inserter **342**. The data into which the pilot is inserted by the pilot inserter **342** is VSB-modulated by the VSB modulator **343** and is transmitted to the broadcasting signal receiver through the RF up-converter **343**.

The transmitter transmits various transmission parameters of the transmission signal such as the main service data or the mobile service data and the broadcasting signal receiver

needs to receive the transmission parameters of the transmitted signal in order to normally receive the transmitted signal. For example, in order to transmit the mobile service data, information indicating how the signals of the symbol area are encoded is required and information indicating how the main service data and the mobile service data are multiplexed is required. A cell identifier may be required in the multi-frequency network environment. Here, information on the transmission parameter is called signaling information. In the embodiment shown in FIG. 9, the signaling information may be inserted by the preprocessor 333 or the second transmission data multiplexer 341 so as to be transmitted. If the second transmission data multiplexer 341 inserts the signaling information, the signaling information may be inserted into a field sync segment area.

FIG. 10 is a view showing an example of the preprocessor shown in FIG. 9. The preprocessor shown in FIG. 9 may include an M-VSB data randomizer 401, a RS frame encoder 402, an M-VSB block processor 403, a group formatter 404, a data deinterleaver 405 and a packet formatter 406.

The M-VSB randomizer 401 randomizes the received mobile service data and outputs the randomized data to the RS frame encoder 402, for error correction encoding. If the M-VSB randomizer 401 randomizes the mobile service data, the data randomizer 335 located at the next stage thereof may omit the randomizing process of the mobile service data.

The RS frame encoder 402 performs the error correction encoding process with respect to the randomized mobile service data. If the RS frame encoder 402 performs the error correction encoding process, burst error which may occur by a variation in propagation environment is distributed while making the mobile service data robust so as to cope with the propagation environment which rapidly varies. The RS frame encoder 402 may include a process of mixing mobile service data having a predetermined size in the unit of data rows.

Hereinafter, as one embodiment, the error correction encoding process may be performed by performing the RS encoding method or the cyclic redundancy check (CRC) encoding method. If the RS encoding method is performed, parity data which will be used for error correction is generated and, if the CRC encoding method is performed, CRC data which will be used for error detection is generated.

The RS encoding method may use a forward error correction (FEC) structure. The CRC data generated by the CRC encoding process may indicate whether the mobile service data is damaged by the error while being transmitted through the channel. The error correction encoding process may use other error detection encoding methods other than the CRC encoding method. Alternatively, the overall error correction capability of the receiver can be increased using the error correction encoding method. The mobile service data encoded by the RS frame encoder 402 is input to the M-VSB block processor 403.

The M-VSB block processor 403 encodes the received mobile service data at G/H encoding rate again and outputs the encoded data to the group formatter 404. The M-VSB block processor 403 separates the received mobile service data based on the byte units into data based on bit units, encodes the separated G-bit data to H-bit data, converts the data into data based on byte units, and outputs the data based on byte units. For example, if 1-bit input data is encoded to 2-bit data and the 2-bit data is output, G becomes 1 and H becomes 2. If 1-bit input data is encoded to 4-bit data and the 4-bit data is output, G becomes 1 and H becomes 4. In the present invention, for convenience of description, the former

case is called encoding of 1/2 encoding rate (also called 1/2 encoding) and the latter case is called encoding of 1/4 encoding rate (also called 1/4 encoding). The 1/4 encoding has higher error correction capability than the 1/2 encoding. Accordingly, the group formatter 404 may allocate the data encoded at the 1/4 encoding rate to an area having low reception capability and allocate the data encoded at the 1/2 encoding rate to an area having high reception capability, thereby reducing a difference in reception capability.

The M-VSB block processor 403 may receive the signaling information included in the transmission parameter information. The data containing the signaling information may be subjected to the 1/2 encoding or the 1/4 encoding. The signaling information is the information necessary for receiving and processing the data included in the data group by the broadcasting signal receiver and may include cell identifier information, data group information, multiplexing information and burst information.

The group formatter 404 inserts the mobile service data output from the M-VSB block processor 403 into a corresponding area in the data group formed according to a predetermined rule. In conjunction with the data deinterleaving, various types of location holders or known data may be inserted into the corresponding area in the data group. The data group may be separated into at least one layered area and the type of the mobile service data inserted into each area may vary according to the characteristics of the layered area. For example, each layered area may be classified according to the reception capability within the data group.

The group formatter 404 may insert the signaling information such as the transmission parameter information into the data group independent of the mobile service data. When the generated known data is inserted into the corresponding area of the mobile service data group, the group formatter 404 may insert the signaling information into at least a portion of the area into which the known data can be inserted, instead of the known data. For example, if a long known data sequence is inserted into the start part of a body area of the mobile service data group, the signaling information is inserted into a portion of the start part, instead of the known data. In this case, a portion of the known data sequence inserted into the remaining area excluding the area, into which the signaling information is inserted, may be used for capturing the start point of the mobile service data group and the other portion may be used for channel equalization in a reception system.

The group formatter 404 may insert an MPEG header location holder, a non-systematic RS parity location holder and a main service data location holder in conjunction with the data deinterleaving of the next stage, in addition to the encoded mobile service data output from the M-VSB block processor 403.

The reason why the main service data location holder is inserted is because an area in which the mobile service data and the main service data are mixed exists on the basis of the data after the data interleaving. For example, the location holder for the MPEG header is allocated to the foremost location of each packet on the basis of the output data after the data deinterleaving.

The group formatter 404 may insert the known data generated by a predetermined method or insert the known data location holder for inserting the known data later. The location holder for initialization of the trellis encoding module may be inserted into a previous area of the known data sequence. The size of the mobile service data which can be inserted into one data group may vary according to

initialization of the trellis inserted into the data group or the size of the known data, the MPEG header and the RS parity.

The data deinterleaver **405** deinterleaves the data and the location holder in the data group output from the group formatter **404** as the inverse process of the interleaving and outputs the deinterleaved data to the packet formatter **406**.

The packet formatter **406** may remove the main service data location holder and the RS parity location holder allocated for the deinterleaving, add 1-byte MPEG sync signal to a 3-byte MPEG header location holder with respect to the remaining data portions, and insert a 4-byte MPEG header.

If the group formatter **404** inserts the known data location holder, the packet formatter **406** may include actual known data to the known data location holder and output the known data location holder without adjustment. Then, the packet formatter **406** divides the data in the packet-formatted data group into mobile service data packets (that is, the MPEG TS packets) based on 188-byte units and outputs the divided data to the multiplexer. The packet formatter **406** may insert the signaling information into at least a portion of the known data area instead of the known data and output the inserted data. If the known data location holder is inserted into the start part of the body area of the mobile service data group, the signaling information may be inserted into a portion of the known data location holder.

If the signaling information is inserted, the inserted signaling information may be block-encoded for a short period and may be inserted or a predefined pattern may be inserted according to the signaling information. The body areas of the mobile service data group may have different known data patterns. Accordingly, in the reception system, only symbols in a promised period may be divided from the known data sequence and be recognized as the signaling information.

FIGS. **8** to **10** show the example of transmitting the broadcasting signal of which mobile reception is possible. Hereinafter, a method for transmitting/receiving a broadcasting signal when a broadcasting signal receiver changes a cell and receives the broadcasting signal will be described.

The method for transmitting/receiving the broadcasting signal according to the present embodiment can transmit/receive the identifier of the cell using the program table information called the PSI/PSIP or can transmit/receive the identifier of the cell using the signaling information including the transmission parameter information.

If the receiver moves between the cells and the cell information is changed, the PSI or PSIP information may be changed and the receiver can obtain the changed cell information according to the changed program table information. For example, if the PSI or the PSIP information is changed, the broadcasting signal receiver can know that the program table information is updated, through the MGT. The MGT defines the packet identifier (PID) of the PSIP table excluding the STT, a version number and a table size. Accordingly, if the table information in the MGT is changed, the version number of the MGT is changed and thus the changed table can be received again. If the CIT which is the program table information having the cell information is changed, the broadcasting signal receiver can recognize the movement between the cells through the MGT.

FIG. **11** is a view showing table type values defined in the MGT which is the program table information having cell information. The MGT delivers the PID value of the version value of every table excluding the STT. That is, the broadcasting signal receiver checks the version-up of other program table information through the MGT and does not check the version of the table information, thereby reducing the

load of the broadcasting system. In the present embodiment, the type of the CIT for delivering the cell information is defined in the MGT so as to check whether the version of the CIT is updated. FIG. **11** shows an example in which the table_type of the CIT is defined by 0x0022. The broadcasting signal receiver can change the channel using the physical channel information of the changed cell using the CIT information and thus the viewer can continuously view the broadcasting program of the channel which has been viewed.

FIG. **12** is a view showing the CIT including cell information. Hereinafter, the cell information of the CIT information will be described with reference to FIG. **12**. The CIT may be transmitted/received as a PSIP table defined in the ATSC and is a table for transmitting/receiving the cell information, of which the version can be managed by the MGT. In the example of FIG. **12**, the identifier (table_id) of the CIT is defined by 0xCE. In addition, "section_syntax_indicator", "private_indicator", "reserved", "section_length", "transport_stream_id", "reserved", "version_number", "current_next_indicator", "section_number", "last_section_number", and "protocol_version" fields may be defined similar to those defined in the MPEG-2 header.

A "num_cells_in_section" field is the number of cells defined in the CIT, which may be equal to the number of transmitters. The broadcasting station may define the information on all the transmitters for transmitting the broadcasting signal in the CIT.

A "cell_id" field is the identifier of the cell according to the signal transmission area of each transmitter and may be matched with the transmitter of each broadcasting station. A "cell_text" field defines the name of each transmitter. For example, "transmitter of Mt. Yongmoon" may be set. A "cell_location" field defines the area in which each transmitter is located. For example, "Mt. Yongmoon" may be set.

A "num_channels_in_cell" field defines the number of broadcasting channels transmitted by each transmitter. A "num_channels_in_cell" field may be the total number of virtual channels in the physical channel transmitted by each transmitter.

The CIT may include information on "major_channel_number", "minor_channel_number", "modulation mode" (for example, QAM, VSB, etc.), "carrier_frequency", "program number", and "reserved" fields.

The CIT may include a descriptor located at a channel level, a descriptor located at a cell unit level, and a descriptor located at a CIT unit level. The CIT may further include a code for error correction.

FIG. **13** is a view showing an example of the MGT for describing a method for transmitting/receiving a broadcasting signal according to an embodiment. Hereinafter, the method for transmitting/receiving the broadcasting signal according to an embodiment will be described with reference to FIG. **13**.

In the method for transmitting/receiving the broadcasting signal, if the handover occurs, the broadcasting signal receiver checks the version number of the MGT so as to recognize the change of the cell. FIG. **13** shows an example of defining the cell identifier defined in the CIT in the reserved field of the MGT. In addition to the field shown in FIG. **13**, the cell identifier defined in the CIT may be configured by various methods.

In FIG. **13**, the "cell_id" field is located next to the "table_id_extension" field of the MGT and includes the index of the cell included in the CIT. The MGT configures a "table_type" field with respect to a "table_defined" field. The broadcasting signal receiver can check whether the

program table information described in FIG. 11 is updated or changed according to the "table_type" field. A "table_type_PID" field configures the PID of the packet for delivering the "table_type" field.

The broadcasting signal receiver can obtain the channel information according to the "cell_id" field defined in the MGT through the CIT information shown in FIG. 12 in the program table information.

The broadcasting signal receiver may parse the MGT which is one of the program table information, obtain the current cell ID, find the cell ID of the CIT having the same cell ID as the cell ID of the MGT, and obtain the channel information of the changed cell. If the broadcasting signal receiver moves to another cell, the MGT is received again and the transport stream information of the CIT using the cell ID of the MGT as the index is updated. Accordingly, the channel information such as "major_channel_number", "minor_channel_number", "modulation mode" (for example, QAM, VSB, etc.), "carrier_frequency", and "program number" field configured in the CIT can be obtained.

FIG. 14 is a view showing an example of a descriptor for describing a method for transmitting/receiving a broadcasting signal according to another embodiment. Hereinafter, the method for transmitting/receiving the broadcasting signal according to another embodiment will be described with reference to FIG. 14.

In FIG. 14, the "cell_id" field may be delivered through the descriptor included in the MGT. In FIG. 14, the descriptor for parsing the "cell_id" field from the MGT is called a "cell_link_descriptor" field. The descriptor shown in FIG. 14 may be parsed from the descriptor of the MGT shown in FIG. 13. The descriptor for parsing the "cell_id" field shown in FIG. 14 may include a "descriptor_tag" field of 0xAB, a "descriptor_length" in byte units, a "cell_id" field, and a "reserved" field.

If the "cell_id" field is parsed from the descriptor of the MGT which is updated at the time of occurrence of handover, the broadcasting signal receiver can obtain the channel information of the changed cell using the same "cell_id" field included in the CIT.

FIG. 15 is a flowchart illustrating a method for transmitting/receiving a broadcasting signal according to another embodiment. The embodiment shown in FIG. 15 is available in the case where the same broadcasting program as the channel of the previous cell is not broadcast in the changed cell, compared with the embodiments shown in FIGS. 13 and 14. If the same broadcasting program as the channel of the previous cell is not broadcast in the changed cell, the update of the MGT version cannot be checked. Since the version of the MGT is not updated even when the power of the signal of the previous cell is decreased, the broadcasting signal receiver cannot detect the handover and thus the broadcasting signal is received from the previous cell. Accordingly, in this case, the handover can be detected using the reception power.

In the present embodiment, first, the broadcasting signal is received from the cell which receives the program table information such as PSI/PSIP and is output (S310). The above-described broadcasting signal includes the mobile service data in addition to the main service data. The broadcasting signal receiver can receive the signal in the burst period of the signal as shown in FIG. 6.

In order to receive the broadcasting signal of E1 in the burst period from the previous cell A and continuously receive the broadcasting signal of E1 in the burst period from the changed cell B, it is determined whether the cell is changed during the reception off period of the broadcasting

signal by the level of the power of the signal (S320). That is, if the power of the signal received from the cell A is less than a first threshold value during the reception off period of the broadcasting signal, it is determined that the handover occurs (Y in the step S320) and, if so not, the broadcasting signal is continuously received from the cell A (N in the step S320).

If the power of the received signal is less than the first threshold value (Y in the step S320), at least one cell identifier included in a cell candidate group is obtained in order to find a cell in which the handover occur and the channel of the cell B is tuned using the channel information of the cell B according to the cell identifier (S330). The cell identifier of the candidate group of the cells in which the handover may occur can be obtained from the signaling information of the received signal. That is, if the cell identifiers of the adjacent cells can be obtained from the signaling information, the channels of the adjacent cells try to be tuned.

If the signal can be received from the channel of the cell B, it is determined whether the power of the signal received from the cell B is greater than a second threshold value (S340). The second threshold value may be equal to the first threshold value. The steps S320, S330 and S340 may be performed in the reception off period of the broadcasting signal.

If it is determined that the received signal is greater than the second threshold value (Y in the step S340), the broadcasting signal is received from the cell B and the cell identifier may be extracted from the signaling information of the signal received from the cell B (S350). Alternatively, the identifier of the cell B may be obtained from the program table information of the cell B.

If it is determined that the received signal is less than the second threshold value in the step S340 (N in the step S340), the signal of the cell A which is the original cell is continuously received (S345) or the step 330 may be repeated with respect to a third cell excluding the cell A and the cell B (the dotted line of the S345). That is, the step S330 may be performed again if the reception off period of the broadcasting signal received from the cell A is long.

FIG. 16 is a flowchart illustrating a method for continuously outputting the same program at the time of occurrence of handover in the method for transmitting/receiving the broadcasting signal.

The broadcasting signal receiver powered on (S410) may receive a user's request for change of the physical channel from any cell (S415). The frequency may be tuned to the changed channel (S420) and the program table information such as the VCT, the PAT or the PMT may be received from the tuned channel (S430).

In order to receive the table associated with the channel in the PSIP or the PSI, the program table information is demultiplexed. For example, if the VCT is parsed from the PSIP or the PSI is included in the received signal, the PAT or the PMT may be parsed (S440).

Then, the A/V PID of the information on the virtual channel selected by the user is detected using the program table information (S450).

It is determined whether the broadcasting signal according to the detected PID is received from a valid channel (S460). That is, if any broadcasting signal is not received through the channel, any broadcasting information is not output on a screen (S465) and the method progresses to the step S430 in order to receive the program table information of the valid channel.

If the selected channel is the valid channel, an elementary stream (ES) according to the A/V PID of the channel is decoded (S470) and the decoded broadcasting signal is output (S480). In this case, additional information such as a channel number or channel information may be decoded and output.

It is determined whether the channel is changed while the broadcasting signal is output (S490). If the physical channel is changed, the method progresses to the step S470 and, if the virtual channel is changed, the method progresses to the step S480. Then, the above-described process is performed so as to output the broadcasting signal of the changed channel.

Like the above-described embodiment, it is assumed that the channel information of the cell is transmitted through the MGT. If the request for the channel change is not received but the cell is changed, it is checked whether the MGT is changed (S510). The broadcasting station can transmit the updated information of the program table information using the version number field of the program table information and the broadcasting signal receiver can determine whether the program table information is updated.

If the version of the MGT is changed, it is checked whether the cell ID is changed from the MGT in order to determine whether the handover occurs (S520). If the cell ID is changed (Y in the step S520), the changed channel information is detected from the CIT using a new cell ID obtained from the MGT (S550).

If the MGT is changed but the cell ID is not changed (N in the step S520), it is determined that the program table information in the same cell is updated and thus the step S430 of receiving the program table information is performed.

If the MGT is not changed, it is determined that the power of the received signal is decreased and the cell ID is extracted from the signaling information (S530). If the cell ID is changed, the changed channel information is detected according to the changed cell ID (S550). If the program of the previous cell is broadcast through another channel of the changed cell, that is, if the physical channel information of the changed cell is changed, the steps after the step S415 is performed (S560).

FIG. 17 is a view showing a broadcasting signal receiver according to an embodiment. The broadcasting signal receiver shown in FIG. 17 includes a tuner 510, a demodulator 520, a demultiplexer 530, a decoder 540, an output unit 550, a controller 560, a memory 570, and a program table information decoder 580.

The operation of the broadcasting signal receiver according to the present embodiment will be described with reference to FIG. 17.

The tuner 510 receives the broadcasting signal including the cell information and selects and outputs the broadcasting signal of a channel according to a control signal of the controller 560 among the broadcasting signals received from the current cell.

The demodulator 520 may demodulate and output the received signal. The signaling information including the cell information may be output and transmitted to the controller 560. The demodulator 520 will be described in detail with reference to FIG. 18.

The demultiplexer 530 may demultiplex program table information (PSI/PSIP) and an audio/video stream in the received signal. Alternatively, a broadcasting stream which will be recorded in or reproduced from a digital recording

device may be received. For example, an input signal according to the IEEE1394 may be directly received without the tuner.

The decoder 540 may decode the audio/video broadcasting signal demultiplexed by the demultiplexer 530. The decoder 540 decodes the audio/video elementary stream packet and outputs the decoded audio/video signal to the output unit 550.

The output unit 550 receives and outputs the audio/video signal decoded by the decoder 540. The output unit 550 includes an on-screen-display (OSD) unit for outputting a graphic signal displayed on a display screen.

The program table information decoder 580 may decode the program table information demultiplexed by the demultiplexer 530 and temporarily store the decoded table information. The program table information decoder may parse the table including the cell information, that is, the MGT, extract the cell information, and output the obtained cell information to the controller 540.

The controller 560 includes an interface for receiving the control signal from the user. The controller 560 stores channel map information in which a physical channel and a virtual channel are mapped such that the tuner 510 selects the channel, and controls the decoder 540 such that the broadcasting stream is output according to the channel request of the user. If the program table information decoder 580 parses the updated table information, the controller 560 stores the updated channel information in the channel map. The controller 560 may store other control information including information necessary for the handover of the broadcasting signal receiver, information on an application and the request information of the user in the memory 570.

When the program table information decoder 580 extracts the cell information, the controller 560 may obtain the channel information of the changed cell using the CIT information decoded by the program table information decoder 580. The controller 560 controls the tuner 510 to tune the channel information of the changed cell such that the broadcasting contents received from the previous cell are output. The controller 560 may control the demodulator 520, the demultiplexer 530 and the decoder 540 to process the tuned signal.

When the demodulator 520 extracts the cell ID included in the signaling information, the controller 560 receives the cell ID and determines whether the handover occurs. If it is determined that the handover occurs, the program table information decoder 580 may parse the CIT information using the cell ID according to the signaling information included in the changed broadcasting signal. The controller 560 may control the tuner 510, the demodulator 520, the demultiplexer 530 and the decoder 540 to process the broadcasting signal of the changed cell from the parsed information.

FIG. 18 is a view showing an example of the demodulator in the broadcasting signal receiver according to FIG. 18 shows the component for decoding the broadcasting signal when the broadcasting signal is transmitted as shown in FIGS. 8 to 10. Hereinafter, the demodulator of the present embodiment will be described with reference to FIG. 1.

The broadcasting signal receiver restores a carrier sync signal, restores a frame sync signal and performs channel equalization using the known data information inserted in the mobile service data period in a transmission system, thereby improving reception capability.

The broadcasting signal receiver includes a VSB demodulator 702, an equalizer 703, a known sequence detector 704, an M-VSB block decoder 705, an M-VSB data deformatter

706, a RS frame decoder 707, an M-VSB derandomizer 708, a data deinterleaver 709, a RS decoder 710, a data derandomizer 711, and a signaling information decoder 712. In FIG. 14, for convenience of description, the M-VSB data deformatter 706, the RS frame decoder 707, and the M-VSB 5 derandomizer 708 are collectively called a mobile service data processor and the data deinterleaver 709, the RS decoder 710 and the data derandomizer 711 are collectively called a main service data processor.

The VSB demodulator 702 and the known sequence detector 704 receive the signal of which the frequency is tuned by the tuner and is down-converted into an intermediate frequency (IF).

The VSB demodulator 702 performs the automatic gain control, the recovery of a carrier and the restoration of a timing in consideration of the VSB method so as to convert the received IF signal to a baseband signal, and outputs the baseband signal to the equalizer 703 and the known sequence detector 704.

The equalizer 703 compensates for the distortion on the channel included in the demodulated signal and outputs the compensated signal to the M-VSB block decoder 705.

At this time, the known sequence detector 704 detects the location of known data inserted at the transmitter side from the input/output data of the VSB demodulator 702, that is, the data before the VSB demodulation or the data after the demodulation. The known sequence detector 704 outputs the location information and the symbol sequence of the known data generated at the location to the VSB demodulator 702 and the equalizer 703. The known sequence detector 704 outputs information for allowing the M-VSB block decoder 705 to distinguish the mobile service data, which is subjected to the additional error correction encoding at the transmitter side, and the main service data, which is not subjected to the additional error correction encoding, to the M-VSB block decoder 705. Although the connection state is not shown in FIG. 14, the information detected by the known sequence detector 704 can be used in the receiver and can be used in the M-VSB data deformatter 706 and the RS frame decoder 707.

The VSB demodulator 702 can improve demodulation capability using the known data symbol sequence at the time of the restoration of the timing or the recovery of the carrier and the equalizer 703 can improve equalization capability using the known data. The decoded result of the M-VSB block decoder 705 may be fed back to the equalizer 703 so as to improve the equalization capability.

If the data received from the equalizer 703 is the mobile service data which is subjected to the additional error correction encoding and the trellis encoding at the transmitter side, the M-VSB block decoder 705 performs trellis decoding and additional error correction decoding as the inverse processes of the transmitter side. If the data is the main service data which is not subjected to the additional encoding and is subjected to the trellis encoding at the transmitter side, only the trellis decoding is performed.

The data group decoded by the M-VSB block decoder 705 is input to the M-VSB data deformatter 706 and the main service data packet is input to the data deinterleaver 709.

If the received data is the main service data, the M-VSB block decoder 705 may perform viterbi decoding with respect to the received data and output a hard decision value or a soft decision value.

If the received data is the mobile service data, the M-VSB block decoder 705 outputs the hard decision value or the soft decision value with respect to the received mobile service data. If the received data is the mobile service data, the

M-VSB block decoder 705 decodes the data which is encoded by the M-VSB block processor and the trellis encoder of the transmission system. In this case, the RS frame encoder of the M-VSB preprocessor of the transmitter side may become an outer code and the M-VSB block processor and the trellis encoder may become an inner code. The decoder of the inner code may output the soft decision value such that the capability of the outer code can be maximized at the time of the decoding of the concatenated code.

Accordingly, the M-VSB block decoder 705 may output the hard decision value with respect to the mobile service data and preferably may output the soft decision value if necessary.

The data deinterleaver 709, the RS decoder 710 and the derandomizer 711 receive and process the main service data. The data deinterleaver 709 deinterleaves the main service data output from the M-VSB block decoder 705 as the inverse process of the data interleaver of the transmitter side and outputs the deinterleaved data to the RS decoder 710.

The RS decoder 710 performs systematic RS decoding with respect to the deinterleaved data and outputs the decoded data to the derandomizer 711. The derandomizer 711 receives the output of the RS decoder 710, generates the same pseudo random byte as the randomizer of the transmitter, performs a bitwise exclusive OR (XOR) with respect to the pseudo random byte, inserts the MPEG sync data in front of every packet, and outputs 188-byte main service data in the packet units.

The data output from the M-VSB block decoder 705 to the M-VSB data deformatter 706 has a data group form. At this time, since the M-VSB data deformatter 706 already knows the configuration of the received data group, it is possible to distinguish the mobile service data and the signaling information having the system information within the data group. The signaling information indicates information for delivering the system information and can deliver the information on the transmission parameter including the identifier of the cell.

The mobile service data is output to the RS frame decoder 707 and the M-VSB data deformatter 706 removes the known data inserted into the data group and the main service data, the trellis initialization data, the MPEG header and the RS parity added in the RS encoder/non-systematic RS encoder or the non-systematic RS encoder of the transmission system and outputs the mobile service data to the RS frame decoder 707.

That is, the RS frame decoder 707 receives only the mobile service data which is subjected to the RS encoding and/or CRC-encoding, from the M-VSB data deformatter 706.

The RS frame decoder 707 performs the inverse process of the RS frame encoder of the transmission system, corrects errors in the RS frame, adds a 1-byte MPEG sync signal which is removed in the RS frame encoding process to the error-corrected mobile service data packet, and the added mobile service data to the M-VSB derandomizer 708.

The M-VSB derandomizer 708 performs the derandomizing process corresponding to the inverse process of the M-VSB randomizer of the transmission system with respect to the received mobile service data and outputs the derandomized data, thereby obtaining the mobile service data transmitted from the transmission system.

The signaling information decoder 712 may decode the signaling information included in the received signal. FIG. 14 shows an example of decoding the signaling information including the identifier of the cell from the M-VSB data

deformatter 706 or the equalizer 703 according to the location of the signal carried in the signaling information.

FIG. 19 is a view showing a broadcasting signal receiver according to another embodiment. Hereinafter, the operation of the broadcasting signal receiver according to the present embodiment will be described with reference to FIG. 19.

The broadcasting signal receiver according to the present embodiment further includes a second memory 620 for storing a program and a memory controller 610 for controlling the second memory 620, in addition to the memory 570 of the broadcasting signal receiver shown in FIG. 17.

The broadcasting service data demultiplexed by the demultiplexer 530 may be decoded by the decoder 540 and may be output and may be input to or read from the second memory 620 by the memory controller 610 for controlling the second memory 620. The demultiplexer 530 may store the main service data or the mobile service data demodulated by the demodulator 520 in the second memory 620.

The controller 560 may control an instant recording function, a reservation recording function, and a time shift function of the broadcasting service data demultiplexed by the demultiplexer 530 through the memory controller 610. The controller 560 may reproduce the broadcasting service data which is already stored in the second memory 620 through the memory controller 610 and the demultiplexer 530.

The second memory 620 may be divided into a temporary storage area for storing the data according to the time shift and a permanent storage area for permanently storing the data according to the selection of the user.

The memory controller 610 may control a play function, a fast forward function, a rewind function, a slow motion function and an instant replay function of the data stored in the second memory 620 according to the control signal of the controller 560. Here, the instant replay function is a function for repeatedly viewing a desired scene. The data which is currently being received in real time as well as the data which is previously stored can be instantly replayed in conjunction with the time shift function.

The memory controller 610 may scramble and store the received data in order to prevent the unauthorized copy of the data stored in the second memory 620. In contrast, the memory controller 610 may read, descramble and store the data which is scrambled and stored in the second memory 620.

If the broadcasting data for data broadcasting is included in the main service data or the mobile service data, the program table information decoder 580 may decode the broadcasting data. The data for data broadcasting may be decoded by the program table information decoder 580 and may be stored in a data storage unit 630.

If the controller 560 operates a data broadcasting application according to the request of the user, the program table information decoder 580 decodes the broadcasting data for data broadcasting and outputs the decoded broadcasting data. The application operated by the controller 560 may implement the data broadcasting output from the program table information decoder 580 and output it to the output unit 550.

The program table information decoder 580 may decode, for example, the service information such as DVB-SI or the broadcasting data according to the PSI or the PSIP. The broadcasting data for data broadcasting may be of a packetized elementary stream type or a section type. That is, the data for data broadcasting includes PES type data or section type data.

For example, the data for data broadcasting is included in a digital storage media-command and control (DSM-CC) section and the DSM-CC section may be composed of the TS packet based on 188-byte units. The identifier of the TS packet included in the DSM-CC section is included in the program table information which is a data service table (DST). If the DST is transmitted, 0x95 is allocated as the value of a stream_type field in the service location descriptor of the PMT or the VCT. The broadcasting signal receiver determines that the data for data broadcasting is received if the value of the stream-type field of the PMT or the VCT is 0x95. The data for data broadcasting may be transmitted by a data carousel method.

In order to process the data for data broadcasting, the demultiplexer 530 may perform section filtering under the control of the program table information decoder 580, discard the overlapping section, and output the non-overlapping section to the program table information decoder 580. The program table information decoder 580 can determine whether the data for data broadcasting included in the broadcasting signal is received according to the PID of the VCT. The PID of the VCT may be set in an MGT and have a fixed value.

The demultiplexer 530 may output only an application information table (AIT) to the program table information decoder 580 through the section filtering. The AIT includes information on an application executed on the broadcasting signal receiver, for the data service.

The AIT may include the information on the application, for example, the name of the application, the version of the application, the priority of the application, the ID of the application, the status of the application (auto-start, operability of the user, kill or the like), the type of the application (Java or HTML), the class of the application, the location of the stream including a data file, the base directory of the application, and the location of the icon of the application. Accordingly, information necessary for executing the application may be stored in the data storage unit 630 using the above-described information.

The application executed by the controller 560 may be received together with the broadcasting data and may be updated. A data broadcasting application manager which is executed in order to allow the controller 560 to execute the application may include a platform for executing an application program. The platform may be, for example, the Java virtual machine for executing the Java program.

If it is assumed that the data broadcasting service is a traffic information service, the broadcasting signal receiver can provide the service to the users through at least one of characters, voice, graphics, still images, moving images or the like although an electronic map or a global positioning system (GPS) module is not mounted. If the broadcasting signal receiver includes the GPS module, the data broadcasting application may be implemented after the GPS module extracts current location information (longitude, latitude, and altitude) received from a satellite. The data storage unit 630 of the broadcasting signal receiver 630 may store the electronic map including information on links and nodes and a variety of graphic information.

FIG. 20 is a view showing a broadcasting signal receiver according to another embodiment. Hereinafter, the operation of the broadcasting signal receiver according to the present embodiment will be described with reference to FIG. 20. The embodiment shown in FIG. 20 can process the scrambled reception signal.

The broadcasting signal receiver according to the embodiment shown in FIG. 20 further includes a first descrambler

640, a second descrambler 65D and an authentication unit 660, in addition to the embodiment shown in FIG. 19. Alternatively, in the embodiment shown in FIG. 16, any one of the first descrambler 640 and the second descrambler 650 may be included. The first descrambler 640 receives and descrambles the signal demultiplexed by the demultiplexer 530. At this time, the first descrambler 64D may receive and use the data necessary for descrambling and the authentication result from the authentication unit 660 in the descrambling. The decoder 540 receives and decodes the signal descrambled by the first descrambler 640 and outputs the decoded signal. If the embodiment shown in FIG. 16 does not include the first descrambler 640, the signal output from the decoder 540 may be descrambled by the second descrambler 650.

The broadcasting signal transmitter may scramble broadcasting contents and transmit the scrambled broadcasting contents in order to provide a service for preventing unauthorized copy or unauthorized viewing of the main service data or the mobile service data or a pay broadcasting service.

The broadcasting signal receiver descrambles the scrambled broadcasting contents and outputs the descrambled broadcasting contents. At this time, an authentication process may be performed by authentication means before the descrambling. In the embodiment shown in FIG. 16, the first descrambler 640, the second descrambler 650 and the authentication unit 660 may be attached to or detached from the broadcasting signal receiver in the form of a slot or a memory stick.

If the scrambled broadcasting contents are received through the tuner 510 and the demodulator 520, the controller 560 may determine whether the received broadcasting contents are scrambled or not. If the received broadcasting contents are scrambled, the authentication unit 660 operates the authentication means.

The authentication unit 660 performs the authentication process in order to determine whether the broadcasting signal receiver is a proper host (broadcasting signal receiver) which can receive the pay broadcasting contents. Various authentication processes may be performed. For example, the authentication unit 660 may perform authentication process by comparing the Internet protocol (IP) address of an IP datagram in the received broadcasting contents with the unique address of the broadcasting signal receiver. The unique address of the broadcasting signal receiver may be a media access control (MAC) address. The authentication unit 660 extracts the IP address from the decapsulated IP datagram and obtains the receiver information mapped with the address. The authentication unit 660 may previously include information (for example, a table form) which can map the IP address with the receiver information and determine whether the IP address and the receiver information are equal to each other by comparison.

Alternatively, the authentication process may be performed by defining standardized identifier at the transmitter/receiver side, transmitting the identifier of the receiver for applying for the pay broadcasting service at the transmitter side, and determining whether the received identifier is equal to the identifier of the receiver at the receiver side. The transmitter side generates and stores the unique identifier of the receiver, which applies for the pay broadcasting service, in a database, and includes the identifier in an entitlement management message (EMM) and transmits the EMM if the broadcasting contents are scrambled. If the broadcasting contents are scrambled, a message (for example, an entitlement control message (ECM) or the EMM) such as conditional access system (CAS) information, mode information

and message location information applied to the scrambling may be transmitted through the data header or another packet.

The ECM may include a control word (CW) used for scrambling. At this time, the CW may be encrypted by an authentication key. The EMM may include the authentication key and the entitlement information of the data. The authentication key may be encrypted by the distribution key of the receiver. If the broadcasting data is scrambled using the CW and information for authentication and information for descrambling are transmitted from the transmitter side, the receiver side may encrypt the CW by the authentication key, include the CW in the ECM, and transmit the ECM.

The transmitter side includes the authentication key used for encrypting the CW and the reception entitlement of the broadcasting signal receiver (for example, a standardized serial number of the broadcasting signal receiver having the reception entitlement) in the EMM and transmits the EMM.

Accordingly, the authentication unit 660 of the broadcasting signal receiver extracts the unique identifier of the receiver, extracts the identifier included in the EMM of the received broadcasting service, determines whether the two identifiers are equal to each other, and performs the authentication process. If it is determined that the two identifiers are equal to each other by the authentication unit 660, the broadcasting signal receiver determine that the broadcasting signal receiver is the proper broadcasting signal receiver having the reception entitlement

Alternatively, the broadcasting signal receiver may include authentication means 3008 in a detachable external module. At this time, the broadcasting signal receiver and the external module interface with each other through a common interface (CI). The external module may receive the scrambled data from the receiver through the CI, perform the descrambling, and transmit only the information necessary for descrambling to the receiver.

The CI includes a physical layer and at least one protocol layer. The protocol layer may have the structure including at least one layer for providing independent function in consideration of extensibility.

The external module may be a memory or card which does not include the descrambling function or a card which includes the descrambling function, while storing the key information and the authentication information used for scrambling. That is, the module may include the descrambling function in the form of hardware, middleware or software.

At this time, the receiver and the external module should be authenticated in order to provide the pay broadcasting service provided by the transmitter side to the user. Accordingly, the transmitter side may provide the pay broadcasting service to the pair of authenticated receiver and module.

The receiver and the external module may authenticate each other through the CI. The external module may communicate with the controller 560 of the receiver through the CI and authenticate the receiver. The broadcasting signal receiver may authenticate the module through the CI. The module may extract and transmit the unique ID of the broadcasting signal receiver and the unique ID of the module to the transmitter in the mutual authentication process. The transmitter side may use the IDs as service start information and payment information. The controller 560 may transmit the payment information to the remote transmitter side through a communication module 670 if necessary.

The authentication unit 660 authenticates the receiver and/or the external module and recognizes the receiver as

the proper receiver which can receive the pay broadcasting service if the authentication process is successfully completed. The authentication unit **660** may receive authentication-related data from a mobile communication service provider in which the user of the receiver registers, instead of the transmitter for providing the broadcasting contents. In this case, the authentication-related data may be scrambled by the transmitter side for providing the broadcasting contents and may be transmitted through the mobile communication service provider or may be scrambled and transmitted by the mobile communication service provider.

If the authentication process of the authentication unit **660** is successfully completed, the receiver may descramble the scrambled broadcasting contents. The descrambling is performed by the descramblers **640** and **650** and the descramblers **640** and **650** may be in the receiver or the external module. The broadcasting signal receiver may include the CI, communicate with the external module including the descramblers **640** and **650**, and descramble the received signal.

If the descramblers **640** and **650** are included in the receiver, the transmitter side (including at least one of the service provider and the broadcasting station) may scramble the data by the same scrambling method and transmit the scrambled data. If the descramblers **640** and **650** are included in the external module, the transmitters may scramble the data by different scrambling methods and transmit the scrambled data.

The controller **560** may communicate with the descramblers **640** and **650** by a predetermined interface. A CI protocol between the receiver and the external module includes a function for periodically checking the status of the counterpart in order to maintain normal mutual communication. The receiver and the module include a function for managing the status of the counterpart using this function, and, if any one of the receiver and the external module malfunctions, reporting the malfunction to the user or the transmitter side and performing a recovery function.

Alternatively, the authentication process may be performed by software, instead of hardware.

That is, if a memory card for previously storing CAS software through downloading is inserted, the broadcasting signal receiver receives and loads the CAS software from the memory card and performs the authentication process. The CAS software read from the memory card is stored in the memories **570** and **620** in the broadcasting signal receiver and is executed on the middleware in the form of one application. The middleware may be, for example, the Java middleware.

The broadcasting signal receiver may include a CI for connection to the memory card. The first memory **570** may be a volatile memory, a non-volatile memory or a flash memory (or a flash ROM). The memory card mainly uses a flash memory or a small-sized hard disc. The memory card may be used in at least one broadcasting signal receiver according to the contents of the stored CAS software, the authentication, the scrambling and the payment method. However, the CAS software includes at least information necessary for authentication and information necessary for descrambling.

Accordingly, the authentication unit **660** performs the authentication between the transmitter side and the broadcasting signal receiver or the broadcasting signal receiver and the memory card. The memory card may include the information on the proper broadcasting receiver which can be authenticated. For example, the information on the broadcasting signal receiver includes unique information such as

the standardized serial number of the broadcasting signal receiver. Accordingly, the authentication unit **660** may compare the unique information such as the standardized serial number included in the memory card with the unique information of the broadcasting signal receiver and perform the authentication process of the memory card and the broadcasting signal receiver.

If the CAS software is executed on the Java middleware, the authentication process of the broadcasting signal receiver and the memory card is performed. For example, it is checked whether the unique number of the broadcasting signal receiver included in the CAS software is equal to the unique number of the broadcasting signal receiver read through the controller **560** of the broadcasting signal receiver. If the unique numbers are equal to each other, the memory card is the normal memory card which can be used in the broadcasting signal receiver. At this time, the CAS software may be included in the memories **570** and **620** at the time of shipment of the broadcasting signal receiver or may be stored in the memories **570** and **620** from the transmitter side, the module or the memory card. The descrambling function may be performed by the data broadcasting application in the form of one application.

The CAS software may parse the EMM/ECM packet output from the demultiplexer **530**, check whether the receiver has the reception entitlement, and obtain and provide the information (that is, the CW) necessary for descrambling to the descramblers **640** and **650**. The CAS software executed on the middleware reads the unique number of the broadcasting signal receiver from the broadcasting signal receiver, compares it with the unique number of the broadcasting signal receiver received by the EMM, and checks the reception entitlement of the current broadcasting signal receiver.

When the reception entitlement of the broadcasting signal receiver is checked, it is checked whether the broadcasting signal receiver has the entitlement for receiving the broadcasting service using the reception entitlement of the broadcasting service and the broadcasting service information transmitted by the ECM. If the entitlement for receiving the broadcasting service is checked, the encrypted CW transmitted by the ECM is decrypted using the authentication key transmitted by the EMM and is output to the descramblers **640** and **650**. The descramblers **640** and **650** descramble the broadcasting service using the CW.

The CAS software stored in the memory card can extend according to the pay service provided by the broadcasting station. The CAS software may include information related to the authentication and the descrambling and additional information. The broadcasting signal receiver may download the CAS software from the transmitter side and upgrade the CAS software stored in the memory card.

The descramblers **640** and **650** may be included in the module in the hardware or software form. In this case, the scrambled reception data may be descrambled by the module and may be decoded.

If the scrambled reception data is stored in the second memory **620**, the scrambled data may be descrambled and stored or the scrambled data may be stored in a state of being descrambled and may be descrambled at the time of reproduction thereof. If the scrambling/descrambling algorithm is included in the memory controller **610**, the memory controller **610** may scramble the scrambled reception signal again and store the scrambled data in the second memory **620**.

Alternatively, the descrambled (conditionally accessed) broadcasting contents are transmitted through a broadcast-

ing network and information related to the authentication for releasing conditional access and the descrambling is transmitted/received through the communication module **670** such that the bidirectional communication is possible in the broadcasting signal receiver.

The broadcasting signal receiver transmits/receives the unique information ID such as the MAC address or the serial number of the broadcasting signal receiver to/from the communication module **670** in the transmitter side such that the transmitter side recognizes the broadcasting data which is desired to be transmitted/received to/from the remote transmitter side and the broadcasting signal receiver to which the broadcasting data is transmitted.

The communication module **670** of the broadcasting signal receiver may support a protocol necessary for performing the bidirectional communication with the communication module **670** of the transmitter side in the broadcasting signal receiver which does not support the bidirectional communication function. The broadcasting signal receiver configures a protocol data unit (PDU) using a tag-length-value (TLV) coding method including the unique information ID and the data to be transmitted. The tag field includes the indexing of the PDU and the length field includes the length of the value field, and the value field includes the unique number ID of the broadcasting signal receiver and actual data to be transmitted.

The broadcasting signal device may mount the Java platform and configure the platform which is operated after downloading the Java application to the broadcasting signal receiver through a network. In this case, the PDU including the tag field which is arbitrarily defined by the transmitter side may be downloaded to the storage medium of the broadcasting signal receiver and may be transmitted to the communication module **670**.

At this time, the broadcasting signal receiver may include the CI and may include a wireless application protocol (WAP) and a CDMA 1×EV-D0, both of which are accessible through a mobile communication base station such as a CDMA or a GSM and a wireless LAN, the mobile Internet, the WiBro, and the Wimax interface, all of which are accessible through an access point, in transmission/reception through a wireless data network.

FIG. **21** is a view showing a broadcasting signal receiver according to another embodiment. The broadcasting signal receiver according to the present embodiment will be described with reference to FIG. **21**. The broadcasting signal receiver includes a tuner **510**, a demodulator **520**, a demultiplexer **530**, an IP filter **535**, a decoder **540**, an output unit **550**, a controller **560**, a memory **570** and a program table information decoder **580**. The operations of the components of the broadcasting signal receiver shown in FIG. **21**, which are equal to those of FIG. **17**, were described with reference to FIG. **17**.

For example, the controller **560** may determine whether the cell which receives the broadcasting signal is changed, from the program table information decoded by the program table information decoder **580**, for example, the MGT, and obtain the cell ID if the cell is changed. Alternatively, the controller may determine whether the handover occurs from the power of the signal received by the tuner **510** and obtain the cell ID from the MGT received from the cell.

The controller **560** may obtain the channel information for transmitting the same broadcasting contents as the broadcasting contents which are received from the previous cell, from the program table information decoded by the program table information decoder **580**, for example, the CIT. The

channel information is the channel information of the broadcasting data identified by the broadcasting stream identifier in each cell.

The controller **560** may control the tuner **510** to tune the channel information of the changed cell and control the demodulator **520**, the demultiplexer **530** and the decoder **540** to process the broadcasting signal of the tuned channel.

In the example shown in FIG. **21**, the demultiplexer **530** may demultiplex the IP stream in addition to the video/audio stream and the program table information from the demodulated signal. If the IP stream is included in a private section of the MPEG-2 TS and is transmitted, the demultiplexer **530** outputs the private section including the IP stream to the program table information decoder **580**. The program table information decoder **580** may decode the private section and output the IP stream to the IP filter **535**. Alternatively, if the IP stream is not included in the private section and an IP datagram is included directly in demodulated stream, the demultiplexer **530** may demultiplexes the IP datagram from the demodulated signal and output the demultiplexed IP datagram to the IP filter **535**.

The IP filter **535** may selectively output the IP stream selected by the user according to the control signal of the controller **560**. The output IP stream may be output to the decoder **540** and the video/audio information included in the IP stream may be output from the output unit **550**. The IP stream may include the first program information and the second program information.

A data handler **561** may process and output the data broadcasting signal transmitted from the IP filter **535** by the IP datagram, and a middleware engine **563** controls the environment of the broadcasting receiving system so as to the broadcasting data and processes and outputs the broadcasting data together with the video/audio data output from the output unit **550**.

The effects of the broadcasting signal receiver and the method for transmitting/receiving the broadcasting signal are as follows.

First, the cell can be identified in the MFN environment and thus the mobile reception of the broadcasting signal is possible. Second, a broadcasting system for mobile reception compatible with a broadcasting system for fixed reception can be provided. Third, although the user moves to an area in which the broadcasting signal is transmitted with a different frequency in the MFN environment, the same broadcasting program can be conveniently viewed without tuning the channel.

It will be apparent to those skilled in the art that various modifications and variations can be made in the present invention without departing from the spirit or scope of the invention. Thus, it is intended that the present invention covers the modifications and variations of this invention provided they come within the scope of the appended claims and their equivalents.

What is claimed is:

- [1. A method of transmitting a broadcast signal, the method comprising:
 - encoding mobile data;
 - forming data groups including the encoded mobile data, known data sequences, signaling information and placeholder bytes for main data, MPEG-2 headers and non-systematic Reed-Solomon (RS) parity,
 - wherein each of the data groups further includes a plurality of regions and the signaling information is inserted into a specific region of the plurality of regions, and

wherein at least two of the known data sequences have different lengths;
 deinterleaving data in each of the data groups;
 removing the placeholder bytes for the main data and the non-systematic RS parity in the deinterleaved data and replacing the placeholder bytes for the MPEG-2 headers in the deinterleaved data with MPEG-2 headers to output data packets;
 multiplexing main data packets including the main data and the data packets to generate multiplexed data packets;
 randomizing the main data in the multiplexed data packets;
 performing systematic RS encoding on the main data packets in the multiplexed data packets and non-systematic RS encoding on the data packets in the multiplexed data packets, wherein the non-systematic RS encoding includes inserting 20 bytes of RS forward error correction (FEC) data obtained from the non-systematic RS encoding into a pre-determined parity byte location within each mobile data packet; and
 transmitting the broadcast signal including the data groups during slots, the slots being time periods for multiplexing the mobile data and the main data.]

[2. The method of claim 1, wherein randomizing the main data in the multiplexed data packets includes randomizing the MPEG-2 headers in the multiplexed data packets.]

[3. The method of claim 1, further comprising interleaving main data in the systematic RS encoded main data packets and mobile data in the non-systematic RS encoded data packets as an inverse process of the deinterleaving.]

[4. The method of claim 1, further comprising block processing the encoded mobile data for encoding with a specific code rate of either 1/2 or 1/4.]

[5. An apparatus for transmitting a broadcast signal, the apparatus comprising:
 a first encoder configured to encode mobile data;
 a group formatter configured to form data groups including the encoded mobile data, known data sequences, signaling information and placeholder bytes for main data, MPEG-2 headers and non-systematic Reed-Solomon (RS) parity,
 wherein each of the data groups includes a plurality of regions and the signaling information is inserted into a specific region of the plurality of regions, and
 wherein at least two of the known data sequences have different lengths;
 a deinterleaver configured to deinterleave data in the each of the data groups;
 a packet formatter configured to remove the placeholder bytes for the main data and the non-systematic RS parity in the deinterleaved data and replace the placeholder bytes for the MPEG-2 headers in the deinterleaved data with MPEG-2 headers to output data packets;
 a multiplexer configured to multiplex main data packets including the main data and the data packets to generate multiplexed data packets;
 a randomizer configured to randomize the main data in the multiplexed data packets;
 a second encoder configured to perform systematic RS encoding on the main data packets in the multiplexed data packets and non-systematic RS encoding on the data packets in the multiplexed data packets, wherein the non-systematic RS encoding includes inserting 20 bytes of RS forward error correction (FEC) data

obtained from the non-systematic RS encoding into a pre-determined parity byte location within each mobile data packet; and
 a transmission unit configured to transmit the broadcast signal including the data groups during slots, the slots being time periods for multiplexing the mobile data and the main data.]

[6. The apparatus of claim 5, wherein the randomizer is further configured to randomize the MPEG-2 headers in the multiplexed data packets.]

[7. The apparatus of claim 5, further comprising an interleaver configured to interleave main data in the systematic RS encoded main data packets and mobile data in the non-systematic RS encoded data packets as an inverse process of the deinterleaver.]

[8. The apparatus of claim 5, further comprising a block processor configured to block process the encoded mobile data for encoding with a specific code rate of either 1/2 or 1/4.]

9. A method of transmitting a broadcast signal in a broadcast transmitter, the method comprising:
 randomizing broadcast service data for a broadcast service, the broadcast service data including a first table;
 encoding the randomized broadcast service data;
 encoding signaling data for signaling the broadcast service data;
 generating a frame including the encoded broadcast service data, the encoded signaling data, and known data information, at least two of the known data information having different patterns,
 wherein the frame includes at least one area including the encoded broadcast service data, the at least one area is classified based on attributes of the at least one area, and
 wherein the encoded signaling data are included in the frame separately from the encoded broadcast service data; and
 transmitting the generated frame,
 wherein the broadcast service data includes signaling information, the signaling information is carried in a signaling table, and
 wherein the signaling table includes:
 an identifier identifying a type of the first table included in the broadcast service data; and
 a version number that is changed when information in the first table is changed.

10. A broadcast transmitter for transmitting a broadcast signal, the broadcast transmitter comprising:
 a randomizer configured to randomize broadcast service data for a broadcast service, the broadcast service data including a first table;
 a first encoder configured to encode the randomized broadcast service data;
 a second encoder configured to encode signaling data for signaling the broadcast service data;
 a frame generator configured to generate a frame including the encoded broadcast service data, the encoded signaling data, and known data information, at least two of the known data information having different patterns,
 wherein the frame includes at least one area including the encoded broadcast service data, the at least one area is classified based on attributes of the at least one area, and
 wherein the encoded signaling data are included in the frame separately from the encoded broadcast service data; and

at least one antenna configured to transmit the generated frame,
 wherein the broadcast service data includes signaling information, the signaling information is carried in a signaling table, and
 wherein the signaling table includes:
 an identifier identifying a type of the first table included in the broadcast service data; and
 a version number that is changed when information in the first table is changed.

11. The method of claim 9,
 wherein the first table includes information about a broadcast stream for the broadcast service, the broadcast stream related to an Radio Frequency (RF) channel which is identified based on geographic area,
 wherein the first table further includes major channel number information and minor channel number information,
 the major channel number information representing a major channel number of the broadcast service, the minor channel number information representing a minor channel number of the broadcast service.

12. The broadcast transmitter of claim 10,
 wherein the first table includes information about a broadcast stream for the broadcast service, the broadcast stream related to an Radio Frequency (RF) channel which is identified based on geographic area,
 wherein the first table further includes major channel number information and minor channel number information,
 the major channel number information representing a major channel number of the broadcast service, the minor channel number information representing a minor channel number of the broadcast service.

13. A method of receiving a broadcast signal in a broadcast receiver, the method comprising:
 receiving a frame;
 parsing the frame including broadcast service data for a broadcast service, signaling data for signaling the broadcast service data and known data information, at least two of the known data information having different patterns, the broadcast service data including a first table,
 wherein the frame includes at least one area including the broadcast service data, the at least one area is classified based on attributes of the at least one area,
 wherein the signaling data are included in the frame separately from the broadcast service data;
 decoding the broadcast service data;
 decoding the signaling data; and
 de-randomizing the decoded broadcast service data,
 wherein the broadcast service data includes signaling information, the signaling information is carried in a signaling table, wherein the signaling table includes:
 an identifier identifying a type of the first table included in the broadcast service data; and

a version number that is changed when information in the first table is changed.

14. A broadcast receiver for receiving a broadcast signal, the broadcast receiver comprising:
 a tuner configured to receive a frame;
 a frame parser configured to parse the frame including broadcast service data for a broadcast service, signaling data for signaling the broadcast service data and known data information, at least two of the known data information having different patterns, the broadcast service data including a first table,
 wherein the frame includes at least one area including the broadcast service data, the at least one area is classified based on attributes of the at least one area,
 wherein the signaling data are included in the frame separately from the broadcast service data;
 a first decoder configured to decode the broadcast service data;
 a second decoder configured to decode the signaling data; and
 a de-randomizer configured to de-randomize the decoded broadcast service data,
 wherein the broadcast service data includes signaling information, the signaling information is carried in a signaling table, wherein the signaling table includes:
 an identifier identifying a type of the first table included in the broadcast service data; and
 a version number that is changed when information in the first table is changed.

15. The method of claim 13,
 wherein the first table includes information about a broadcast stream for the broadcast service, the broadcast stream related to an Radio Frequency (RF) channel which is identified based on geographic area,
 wherein the first table further includes major channel number information and minor channel number information,
 the major channel number information representing a major channel number of the broadcast service, the minor channel number information representing a minor channel number of the broadcast service.

16. The broadcast receiver of claim 14,
 wherein the first table includes information about a broadcast stream for the broadcast service, the broadcast stream related to an Radio Frequency (RF) channel which is identified based on geographic area,
 wherein the first table further includes major channel number information and minor channel number information,
 the major channel number information representing a major channel number of the broadcast service, the minor channel number information representing a minor channel number of the broadcast service.