

US00RE46802E

(19) **United States**
(12) **Reissued Patent**
de Villiers et al.

(10) **Patent Number: US RE46,802 E**
(45) **Date of Reissued Patent: Apr. 24, 2018**

- (54) **INTERVERTEBRAL PROSTHETIC DISC WITH METALLIC CORE**
- (71) Applicant: **Simplify Medical Pty Ltd**, Paddington (AU)
- (72) Inventors: **Malan de Villiers**, Wapadrand (ZA); **Ulrich Hahnle**, Saxonwold (ZA); **David Hovda**, Mountain View, CA (US)
- (73) Assignee: **Simplify Medical Pty Limited** (AU)
- (21) Appl. No.: **15/293,530**
- (22) Filed: **Oct. 14, 2016**

Related U.S. Patent Documents

Reissue of:

- (64) Patent No.: **8,002,834**
- Issued: **Aug. 23, 2011**
- Appl. No.: **12/431,420**
- Filed: **Apr. 28, 2009**

U.S. Applications:

- (60) Division of application No. 10/903,913, filed on Jul. 30, 2004, now Pat. No. 7,575,599, and a continuation-in-part of application No. 12/101,664, filed on Apr. 11, 2008, which is a continuation-in-part of application No. 10/855,817, filed on May 26, 2004, now Pat. No. 7,442,211.

(Continued)

- (51) **Int. Cl.**
A61F 2/44 (2006.01)
- (52) **U.S. Cl.**
CPC *A61F 2/442* (2013.01)
- (58) **Field of Classification Search**
CPC A61F 2/4425; A61F 2/442; A61F 2/3099
USPC 623/17.11–17.16
See application file for complete search history.

(56) **References Cited**

U.S. PATENT DOCUMENTS

3,486,505 A	12/1969	Morrison
3,867,728 A	2/1975	Stubstad et al.

(Continued)

FOREIGN PATENT DOCUMENTS

DE	3023353 A1	4/1981
DE	3023353 A1	9/1981

(Continued)

OTHER PUBLICATIONS

International search report and written opinion dated Sep. 21, 2006 for PCT/US2005/026160.

(Continued)

Primary Examiner — Beverly M Flanagan

(74) *Attorney, Agent, or Firm* — Wilson Sonsini Goodrich & Rosati

(57) **ABSTRACT**

A prosthetic disc for insertion between adjacent vertebrae includes a core having upper and lower curved surfaces and upper and lower plates. At least one of the curved surfaces of the core is metallic, and in some embodiments the entire core is metallic. Each plate has an outer surface which engages a vertebra and a metallic inner curved surface which is shaped to slide over one of the curved surfaces of the core. In some embodiments, the center of rotation of the core is free to move relative to the upper and lower metallic plates. In some embodiments, one or more channels extend across one or both of the curved surfaces of the core for allowing passage of bodily fluid to promote lubrication between the core and at least one of the plates.

13 Claims, 4 Drawing Sheets

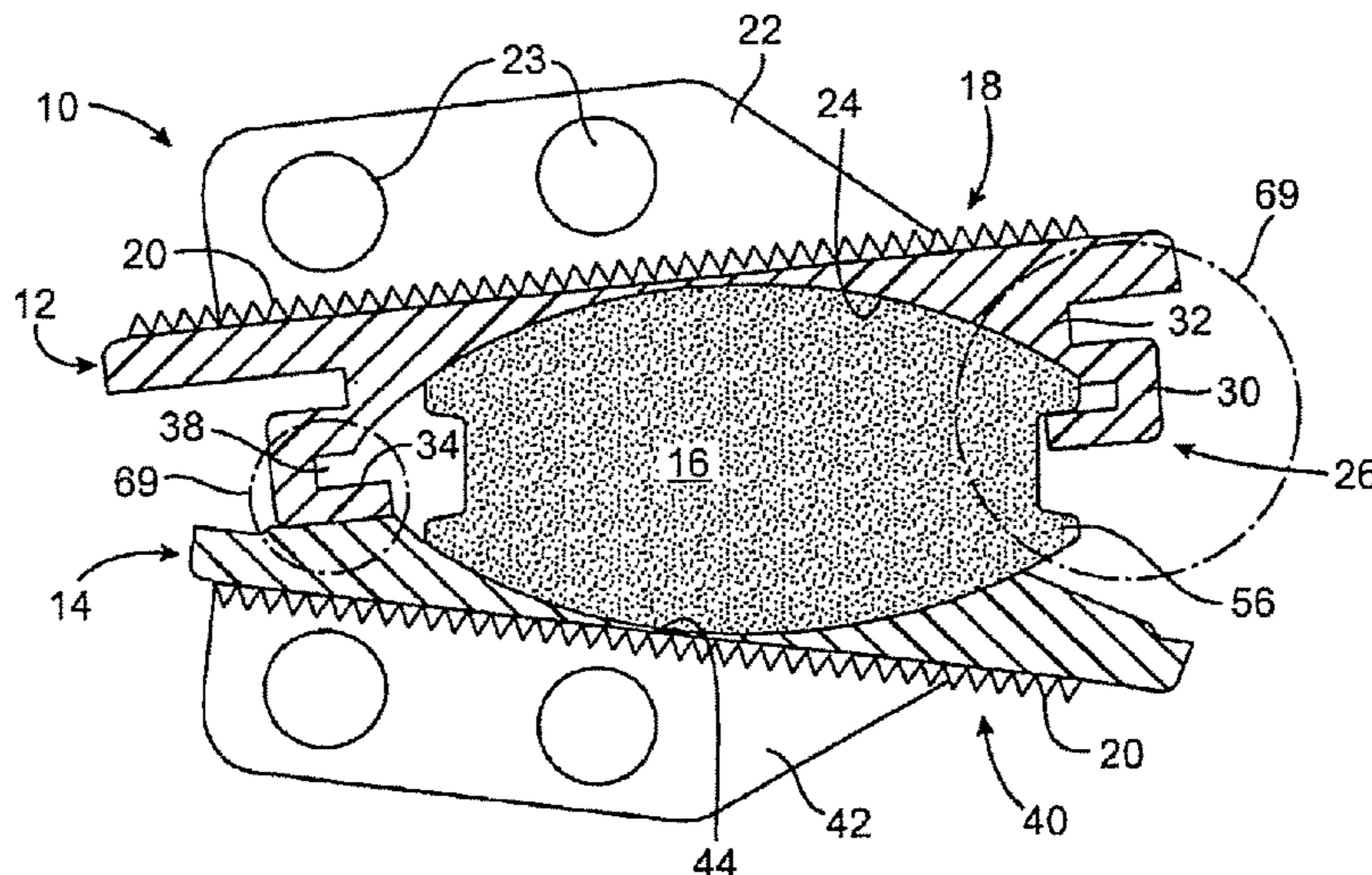

Related U.S. Application Data

(60) Provisional application No. 60/473,803, filed on May 27, 2003, provisional application No. 60/473,802, filed on May 27, 2003.

(56) **References Cited**

U.S. PATENT DOCUMENTS

4,309,777 A 1/1982 Patil
 4,531,917 A 7/1985 Linkow et al.
 4,566,466 A 1/1986 Ripple et al.
 4,619,660 A 10/1986 Christiansen et al.
 4,673,407 A 6/1987 Martin
 4,759,766 A 7/1988 Buttner-Janz et al.
 4,759,769 A 7/1988 Hedman et al.
 4,834,757 A 5/1989 Brantigan
 4,863,477 A 9/1989 Monson
 4,904,261 A 2/1990 Dove et al.
 4,917,704 A 4/1990 Frey et al.
 4,932,969 A 6/1990 Frey et al.
 4,946,378 A 8/1990 Hirayama et al.
 4,997,432 A 3/1991 Keller
 5,035,716 A 7/1991 Downey
 5,057,108 A 10/1991 Shetty et al.
 5,071,437 A 12/1991 Steffee
 5,122,130 A 6/1992 Keller
 5,195,526 A 3/1993 Michelson
 5,258,031 A 11/1993 Salib et al.
 5,282,861 A 2/1994 Kaplan
 5,314,477 A 5/1994 Marnay
 5,320,644 A 6/1994 Baumgartner
 5,370,697 A 12/1994 Baumgartner
 5,394,457 A 2/1995 Leibinger et al.
 5,401,269 A 3/1995 Buttner-Janz et al. A61F 2/4425
 606/247
 5,415,704 A 5/1995 Davidson
 5,458,642 A 10/1995 Beer et al.
 5,462,575 A 10/1995 Del Corso
 5,484,437 A 1/1996 Michelson
 5,489,307 A 2/1996 Kuslich et al.
 5,505,732 A 4/1996 Michelson
 5,507,816 A 4/1996 Bullivant
 5,534,030 A 7/1996 Navarro et al.
 5,556,431 A * 9/1996 Buttner-Janz 623/17.15
 5,674,296 A 10/1997 Bryan et al.
 5,676,701 A 10/1997 Yuan et al.
 5,676,702 A 10/1997 Ratron
 5,683,465 A 11/1997 Shinn et al.
 5,702,450 A 12/1997 Bisserie
 5,709,683 A 1/1998 Bagby
 5,728,159 A 3/1998 Stroever et al.
 5,741,253 A 4/1998 Michelson
 5,776,198 A 7/1998 Rabbe et al.
 5,782,832 A 7/1998 Larsen et al.
 5,797,909 A 8/1998 Michelson
 5,824,094 A 10/1998 Serhan et al.
 5,836,948 A 11/1998 Zucherman et al.
 5,865,846 A 2/1999 Bryan et al.
 5,865,848 A 2/1999 Baker
 5,888,226 A * 3/1999 Rogozinski 623/17.16
 5,895,428 A 4/1999 Berry
 5,899,901 A 5/1999 Middleton
 5,899,911 A 5/1999 Carter
 5,928,284 A 7/1999 Mehdizadeh
 5,989,251 A 11/1999 Nichols
 5,989,291 A 11/1999 Ralph et al.
 6,001,130 A 12/1999 Bryan et al.
 6,019,792 A 2/2000 Cauthen
 6,022,376 A 2/2000 Assell et al.
 6,039,761 A 3/2000 Li et al.
 6,039,763 A 3/2000 Shelokov
 6,080,155 A 6/2000 Michelson
 6,083,228 A 7/2000 Michelson
 6,086,613 A 7/2000 Camino et al.
 6,096,038 A 8/2000 Michelson
 6,132,465 A 10/2000 Ray et al.

6,136,031 A 10/2000 Middleton
 6,139,551 A 10/2000 Michelson et al.
 6,139,579 A 10/2000 Steffee et al.
 6,143,033 A 11/2000 Paul et al.
 6,146,421 A 11/2000 Gordon et al.
 6,156,067 A 12/2000 Bryan et al.
 6,159,214 A 12/2000 Michelson
 6,162,252 A 12/2000 Kuras et al.
 6,174,311 B1 1/2001 Branch et al.
 6,176,881 B1 1/2001 Schar et al.
 6,193,757 B1 2/2001 Foley et al.
 6,224,595 B1 5/2001 Michelson
 6,224,607 B1 5/2001 Michelson
 6,231,609 B1 5/2001 Mehdizadeh
 6,235,030 B1 5/2001 Zucherman et al.
 6,261,296 B1 7/2001 Aebi et al.
 6,264,695 B1 7/2001 Stoy
 6,290,726 B1 9/2001 Pope et al.
 6,296,664 B1 10/2001 Middleton
 6,315,797 B1 11/2001 Middleton
 6,322,567 B1 11/2001 Mittelstadt et al.
 6,336,941 B1 1/2002 Subba Rao et al.
 6,348,071 B1 2/2002 Steffee et al.
 6,368,350 B1 4/2002 Erickson et al.
 6,368,351 B1 4/2002 Glenn et al.
 6,375,681 B1 4/2002 Truscott
 6,375,682 B1 4/2002 Fleischmann et al.
 6,395,032 B1 5/2002 Gauchet
 6,402,785 B1 6/2002 Zdeblick et al.
 6,409,766 B1 6/2002 Brett
 6,413,278 B1 7/2002 Marchosky
 6,416,551 B1 7/2002 Keller
 6,436,098 B1 8/2002 Michelson
 6,440,139 B2 8/2002 Michelson
 6,447,544 B1 9/2002 Michelson
 6,478,800 B1 11/2002 Fraser et al.
 6,517,544 B1 2/2003 Michelson
 6,517,580 B1 2/2003 Ramadan et al.
 6,520,967 B1 2/2003 Cauthen
 6,520,996 B1 2/2003 Manasas et al.
 6,527,804 B1 3/2003 Gauchet et al.
 6,533,817 B1 3/2003 Norton et al.
 6,537,279 B1 3/2003 Michelson
 6,554,863 B2 4/2003 Paul et al.
 6,562,047 B2 5/2003 Ralph et al.
 6,562,074 B2 5/2003 Gerbec et al.
 6,565,574 B2 5/2003 Michelson
 6,582,466 B1 6/2003 Gauchet
 6,582,468 B1 6/2003 Gauchet
 6,592,624 B1 7/2003 Fraser et al.
 6,599,294 B2 7/2003 Fuss et al.
 6,607,558 B2 8/2003 Karus
 6,607,559 B2 8/2003 Ralph et al.
 6,610,092 B2 8/2003 Ralph et al.
 6,623,525 B2 9/2003 Ralph et al.
 6,645,248 B2 11/2003 Casutt
 6,648,895 B2 11/2003 Burkus et al.
 6,652,533 B2 11/2003 O'Neil
 6,660,038 B2 12/2003 Boyer, II et al.
 6,666,866 B2 12/2003 Mertz et al.
 6,669,731 B2 12/2003 Ralph et al.
 6,669,732 B2 12/2003 Serhan et al.
 6,673,113 B2 1/2004 Ralph et al.
 6,682,562 B2 1/2004 Viart et al.
 6,689,132 B2 2/2004 Biscup
 6,706,068 B2 3/2004 Ferree
 6,709,439 B2 3/2004 Rogers et al.
 6,711,723 B2 3/2004 Roger et al.
 6,712,819 B2 3/2004 Zucherman et al.
 6,712,825 B2 3/2004 Aebi et al.
 6,723,097 B2 4/2004 Fraser et al.
 6,726,720 B2 4/2004 Ross et al.
 6,733,532 B1 5/2004 Gauchet et al.
 6,740,118 B2 5/2004 Eisermann et al.
 6,740,119 B2 5/2004 Ralph et al.
 6,755,841 B2 6/2004 Fraser et al.
 6,764,512 B2 7/2004 Keller
 6,764,515 B2 7/2004 Ralph et al.
 6,770,095 B2 8/2004 Grinberg et al.

(56)

References Cited

U.S. PATENT DOCUMENTS

6,790,233 B2	9/2004	Brodke et al.	2002/0091392 A1	7/2002	Michelson
6,793,678 B2	9/2004	Hawkins	2002/0116009 A1	8/2002	Fraser et al.
6,814,737 B2	11/2004	Cauthan	2002/0123753 A1	9/2002	Michelson
6,821,298 B1	11/2004	Jackson	2002/0128715 A1	9/2002	Bryan et al.
6,827,740 B1	12/2004	Michelson	2002/0165550 A1	11/2002	Frey et al.
6,830,570 B1	12/2004	Frey et al.	2002/0177897 A1	11/2002	Michelson
6,846,328 B2	1/2005	Cauthan	2002/0198532 A1	12/2002	Michelson
6,863,673 B2	3/2005	Gerbec et al.	2003/0009224 A1	1/2003	Kuras
6,875,213 B2	4/2005	Michelson	2003/0023245 A1	1/2003	Ralph et al.
6,896,680 B2	5/2005	Michelson	2003/0028249 A1	2/2003	Baccelli et al.
6,899,735 B2	5/2005	Coates et al.	2003/0040746 A1	2/2003	Mitchell et al.
6,936,071 B1	8/2005	Marnay et al.	2003/0045884 A1	3/2003	Robie et al.
6,936,132 B2	8/2005	Topolnitsky	2003/0045939 A1	3/2003	Casutt
6,963,071 B2	11/2005	Bristol	2003/0074076 A1	4/2003	Ferree et al.
6,964,686 B2	11/2005	Gordon	2003/0083747 A1	5/2003	Winterbottom et al.
6,966,929 B2	11/2005	Mitchell	2003/0100951 A1	5/2003	Serhan et al.
6,989,011 B2	1/2006	Paul et al.	2003/0125739 A1	7/2003	Bagga
6,994,727 B2	2/2006	Khandkar et al.	2003/0130662 A1	7/2003	Michelson
7,011,684 B2	3/2006	Eckman	2003/0135277 A1	7/2003	Bryan et al.
7,022,138 B2	4/2006	Mashburn	2003/0139812 A1	7/2003	Garcia et al.
7,025,787 B2	4/2006	Bryan et al.	2003/0187448 A1	10/2003	Michelson
7,044,983 B1	5/2006	Cheng	2003/0191536 A1	10/2003	Ferree
7,056,344 B2	6/2006	Huppert et al.	2003/0195517 A1	10/2003	Michelson
7,060,073 B2	6/2006	Frey et al.	2003/0195631 A1	10/2003	Ferree
7,066,958 B2	6/2006	Ferree	2003/0199982 A1	10/2003	Bryan
7,081,120 B2	7/2006	Li et al.	2003/0204261 A1	10/2003	Eisermann et al.
7,083,651 B2	8/2006	Diaz et al.	2003/0208271 A1	11/2003	Kuras
7,087,055 B2	8/2006	Lim et al.	2003/0229358 A1	12/2003	Errico et al.
7,097,648 B1	8/2006	Globerman et al.	2003/0233145 A1	12/2003	Landry et al.
7,115,132 B2	10/2006	Errico et al.	2004/0002761 A1	1/2004	Rogers et al.
7,118,580 B1	10/2006	Beyersdorff et al.	2004/0024407 A1	2/2004	Ralph
7,147,665 B1	12/2006	Bryan et al.	2004/0024410 A1	2/2004	Olson et al.
7,153,325 B2	12/2006	Kim et al.	2004/0030391 A1	2/2004	Ferree
7,179,294 B2	2/2007	Eisermann et al.	2004/0034426 A1	2/2004	Errico et al.
7,182,784 B2	2/2007	Evans et al.	2004/0054411 A1	3/2004	Kelly et al.
7,198,644 B2	4/2007	Schultz et al.	2004/0059318 A1	3/2004	Zhang et al.
7,207,991 B2	4/2007	Michelson	2004/0073307 A1	4/2004	Keller
7,214,244 B2	5/2007	Zubok et al.	2004/0073311 A1	4/2004	Ferree
7,217,291 B2	5/2007	Zucherman et al.	2004/0073312 A1	4/2004	Eisermann et al.
7,235,082 B2	6/2007	Bartish et al.	2004/0093087 A1	5/2004	Ferree et al.
7,235,103 B2	6/2007	Rivin	2004/0097928 A1	5/2004	Zdeblick et al.
7,250,060 B2	7/2007	Trieu	2004/0098131 A1	5/2004	Bryan et al.
7,255,714 B2	8/2007	Malek	2004/0117021 A1	6/2004	Biedermann et al.
7,261,739 B2	8/2007	Ralph et al.	2004/0143270 A1	7/2004	Zucherman et al.
7,267,688 B2	9/2007	Ferree	2004/0143332 A1	7/2004	Krueger et al.
7,270,679 B2 *	9/2007	Istephanous et al. A61B 17/7052 623/17.11	2004/0143334 A1	7/2004	Ferree
7,270,682 B2	9/2007	Frigg et al.	2004/0167626 A1	8/2004	Geremakis et al.
7,303,583 B1	12/2007	Schar et al.	2004/0176843 A1	9/2004	Zubok et al.
7,318,839 B2	1/2008	Malberg et al.	2004/0186569 A1	9/2004	Berry
7,326,250 B2	2/2008	Beaurain et al.	2004/0215342 A1	10/2004	Suddaby
7,331,995 B2	2/2008	Eisermann et al.	2004/0225295 A1	11/2004	Zubok et al.
7,429,270 B2	9/2008	Baumgartner et al.	2004/0225365 A1	11/2004	Eisermann et al.
7,442,211 B2	10/2008	de Villiers et al. ... A61F 2/4425 623/17.14	2004/0236426 A1	11/2004	Ralph et al.
7,452,380 B2	11/2008	Zubok et al.	2004/0254644 A1	12/2004	Taylor
7,491,241 B2	2/2009	Errico et al.	2005/0015094 A1	1/2005	Keller
7,494,508 B2	2/2009	Zeegers	2005/0015095 A1	1/2005	Keller
7,549,995 B2	6/2009	Schultz et al.	2005/0015152 A1	1/2005	Sweeney
7,575,599 B2 *	8/2009	Villiers et al. 623/17.14	2005/0021145 A1	1/2005	de Villiers et al.
7,582,115 B2	9/2009	Weber	2005/0021146 A1	1/2005	de Villiers et al.
7,682,396 B2	3/2010	Beaurain et al.	2005/0027360 A1	2/2005	Webb et al.
7,708,776 B1	5/2010	Blain et al.	2005/0038515 A1	2/2005	Kunzler
7,753,956 B2	7/2010	De Villiers et al.	2005/0043800 A1	2/2005	Paul et al.
8,062,371 B2	11/2011	De Villiers et al.	2005/0085917 A1	4/2005	Marnay et al.
8,444,695 B2	5/2013	De Villiers et al.	2005/0107881 A1	5/2005	Alleyne et al.
8,454,698 B2	6/2013	De Villiers et al.	2005/0113842 A1	5/2005	Bertagnoli et al.
9,107,762 B2	8/2015	De Villiers et al.	2005/0113928 A1	5/2005	Cragg
2001/0016773 A1	8/2001	Serhan et al.	2005/0143824 A1	6/2005	Richelsoph et al.
2001/0029377 A1	10/2001	Aebi et al.	2005/0149189 A1	7/2005	Mokhtar et al.
2002/0022845 A1	2/2002	Zdeblick et al.	2005/0154463 A1	7/2005	Trieu
2002/0035400 A1	3/2002	Bryan et al.	2005/0165408 A1	7/2005	Puno et al.
2002/0045904 A1	4/2002	Fuss et al.	2005/0192586 A1	9/2005	Zuckerman et al.
2002/0068936 A1	6/2002	Burkus et al.	2005/0192670 A1	9/2005	Zubok et al.
			2005/0197706 A1	9/2005	Hovorka et al.
			2005/0216081 A1	9/2005	Taylor
			2005/0216084 A1	9/2005	Fleischmann et al.
			2005/0234553 A1	10/2005	Gordon
			2005/0251260 A1	11/2005	Gerber et al.
			2005/0251261 A1	11/2005	Peterman
			2005/0251262 A1	11/2005	de Villiers et al.

(56)

References Cited

U.S. PATENT DOCUMENTS

2005/0261772 A1 11/2005 Filippi et al.
 2005/0267580 A1 12/2005 Suddaby
 2005/0267581 A1 12/2005 Marnay et al.
 2006/0004377 A1 1/2006 Keller
 2006/0004453 A1 1/2006 Bartish et al.
 2006/0015183 A1 1/2006 Gilbert et al.
 2006/0020342 A1 1/2006 Ferree et al.
 2006/0025862 A1 2/2006 de Villiers et al.
 2006/0029186 A1 2/2006 de Villiers et al.
 2006/0030857 A1 2/2006 de Villiers et al.
 2006/0030862 A1 2/2006 de Villiers et al.
 2006/0036325 A1 2/2006 Paul et al.
 2006/0041313 A1 2/2006 Allard et al.
 2006/0041314 A1 2/2006 Millard
 2006/0052870 A1 3/2006 Feree
 2006/0069439 A1 3/2006 Zucherman et al.
 2006/0116768 A1 6/2006 Krueger et al.
 2006/0142858 A1 6/2006 Colleran
 2006/0142862 A1 6/2006 Diaz et al.
 2006/0155378 A1 7/2006 Eckman
 2006/0167549 A1 7/2006 Mathys et al.
 2006/0178744 A1 8/2006 de Villiers et al.
 2006/0178746 A1 8/2006 Bartish, Jr. et al.
 2006/0195097 A1 8/2006 Evans et al.
 2006/0200239 A1 9/2006 Rothman et al.
 2006/0224241 A1 10/2006 Butler et al.
 2006/0235426 A1 10/2006 Lim et al.
 2006/0235525 A1 10/2006 Gil et al.
 2006/0235527 A1 10/2006 Buettner-Janz et al.
 2006/0241641 A1 10/2006 Albans et al.
 2006/0241766 A1 10/2006 Felton et al.
 2006/0259144 A1 11/2006 Trieu
 2006/0259146 A1 11/2006 Navarro et al.
 2006/0265068 A1 11/2006 Schwab
 2006/0293752 A1 12/2006 Moumene et al.
 2006/0293754 A1 12/2006 de Villiers et al.
 2007/0010826 A1 1/2007 Rhoda et al.
 2007/0021837 A1 1/2007 Ashman et al.
 2007/0032875 A1 2/2007 Blacklock et al.
 2007/0061011 A1 3/2007 de Villiers et al.
 2007/0067035 A1 3/2007 Falahee
 2007/0067036 A1 3/2007 Hudgins et al.
 2007/0073398 A1 3/2007 Fabian et al.
 2007/0093898 A1 4/2007 Schwab et al.
 2007/0100453 A1 5/2007 Parsons et al.
 2007/0100454 A1 5/2007 Burgess et al.
 2007/0100456 A1 5/2007 Dooris et al.
 2007/0123903 A1 5/2007 Raymond et al.
 2007/0123904 A1 5/2007 Stad et al.
 2007/0135923 A1 6/2007 Peterman et al.
 2007/0162133 A1 7/2007 Doubler et al.
 2007/0168033 A1 7/2007 Kim et al.
 2007/0168036 A1 7/2007 Ainsworth et al.
 2007/0179615 A1 8/2007 Heinz et al.
 2007/0213821 A1 9/2007 Kwak et al.
 2007/0233077 A1 10/2007 Khalili
 2007/0233247 A1 10/2007 Schwab
 2007/0233248 A1 10/2007 Schwab et al.
 2007/0233251 A1 10/2007 Abdou
 2007/0270970 A1 11/2007 Trieu
 2007/0282449 A1 12/2007 de Villiers et al.
 2007/0299521 A1 12/2007 Glenn et al.
 2008/0015698 A1 1/2008 Marino et al.
 2008/0015701 A1 1/2008 Garcia et al.
 2008/0021557 A1 1/2008 Trieu
 2008/0051900 A1 2/2008 de Villiers et al.
 2008/0051901 A1 2/2008 de Villiers et al.
 2008/0125864 A1 5/2008 de Villiers et al.
 2008/0133011 A1 6/2008 de Villiers et al.
 2008/0154301 A1 6/2008 de Villiers et al.
 2008/0154382 A1 6/2008 de Villiers et al.
 2008/0215155 A1 9/2008 de Villiers et al.
 2008/0221696 A1 9/2008 de Villiers et al.
 2008/0228274 A1 9/2008 de Villiers et al.
 2008/0228277 A1 9/2008 de Villiers et al.

2008/0294259 A1 11/2008 de Villiers et al.
 2009/0043391 A1 2/2009 de Villiers et al.
 2009/0048674 A1 2/2009 Zubok et al.
 2009/0048677 A1 2/2009 McLeod et al.
 2009/0076614 A1 3/2009 Arramon
 2009/0105833 A1 4/2009 Hovda et al.
 2009/0105834 A1 4/2009 Hovda et al.
 2009/0105835 A1 4/2009 Hovda et al.
 2009/0210060 A1 8/2009 de Villiers et al.
 2010/0004746 A1 1/2010 Arramon
 2010/0016972 A1 1/2010 Jansen et al.
 2010/0016973 A1 1/2010 de Villiers et al.
 2010/0049040 A1 2/2010 de Villiers et al.
 2010/0069976 A1 3/2010 de Villiers et al.
 2010/0076558 A1 3/2010 de Villiers et al.
 2010/0087868 A1 4/2010 Barr et al.

FOREIGN PATENT DOCUMENTS

DE 10035182 A1 2/2002
 EP 0 333 990 A2 9/1989
 EP 0333990 A3 5/1990
 EP 0 560 140 A1 9/1993
 EP 0 560 141 A1 9/1993
 EP 0 591 712 A1 4/1994
 EP 0 820 740 1/1998
 EP 1 142 544 A1 10/2001
 EP 1 153 582 A2 11/2001
 EP 1153582 A3 11/2001
 EP 1 250 898 A1 10/2002
 EP 1 306 064 A1 5/2003
 EP 1 344 493 A1 9/2003
 EP 1 344 506 A1 9/2003
 EP 1 344 507 A2 9/2003
 EP 1 344 508 A3 9/2003
 EP 1 405 615 A1 4/2004
 EP 1 417 940 A1 5/2004
 EP 1 570 813 9/2005
 FR 2 803 741 7/2001
 JP 61-122859 6/1986
 JP 63-164948 7/1988
 JP 01-136655 5/1989
 JP 06-007391 1/1994
 JP 2002-5210900 T 7/2002
 JP 2003-508119 T 3/2003
 WO WO 99/20209 4/1999
 WO WO 99/30651 6/1999
 WO WO 00/04851 2/2000
 WO WO 00/35384 6/2000
 WO WO 00/42954 7/2000
 WO WO 01/01893 A1 1/2001
 WO WO 01/015637 3/2001
 WO WO 01/68003 A1 9/2001
 WO WO 02/11650 2/2002
 WO WO-0211650 A3 9/2003
 WO WO 2004/000170 12/2003
 WO WO 2004/000171 12/2003
 WO WO 2004/026187 A1 4/2004
 WO WO 2004/041131 5/2004
 WO WO 2004/054477 7/2004
 WO WO-2004041131 A3 9/2004
 WO WO 2005/004756 A2 1/2005
 WO WO 2005/004756 A3 1/2005
 WO WO 2005/004757 A1 1/2005
 WO WO 2005/053580 A1 6/2005
 WO WO 2005/072662 8/2005
 WO WO 2005/112834 12/2005
 WO WO-2006014830 A2 2/2006
 WO WO-2005112834 A3 5/2006
 WO WO 2006/119092 A2 11/2006
 WO WO 2006/119092 A3 11/2006
 WO WO 2007/121320 10/2007
 WO WO-2007121320 A3 6/2008
 ZA 03/9312 11/2003

(56)

References Cited

OTHER PUBLICATIONS

Buttner-Janzen, "The Development of the Artificial Disc," Introduction, pp. 1-18, Library of Congress Catalogue No. 92-75582, ISBN 0-9635430-0-8 (1989).

Hellier et al., "Wear Studies for Development of an Intervertebral Disc Prosthesis," *Spine*, vol. 17 No. 6 Supplement pp. 86-96 (1992).

Lee et al., "Impact Response of the Intervertebral Disc in a Finite-Element Model," *Spine* vol. 25, No. 19, pp. 2431-2439 (2000).

Lehuc et al., "Shock Absorption in Lumbar Disc Prosthesis," *Journal of Spinal Disorders & Techniques*, vol. 16, No. 4, pp. 346-351(2003).

Office Action of Japanese Patent Application No. 2007-523673, mailed Feb. 12, 2010, 9 pages total. (English Translation Included).

* cited by examiner

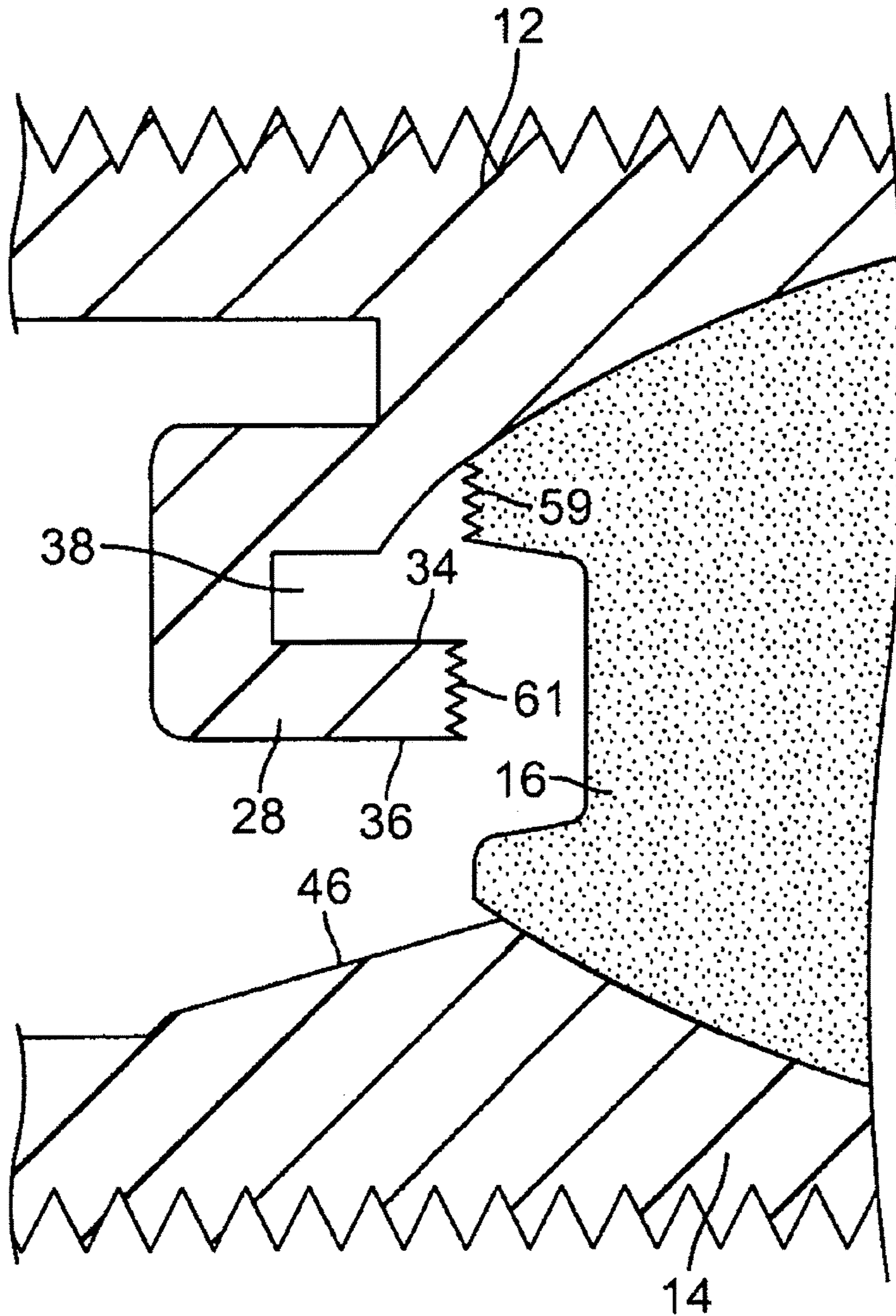

FIG. 1A

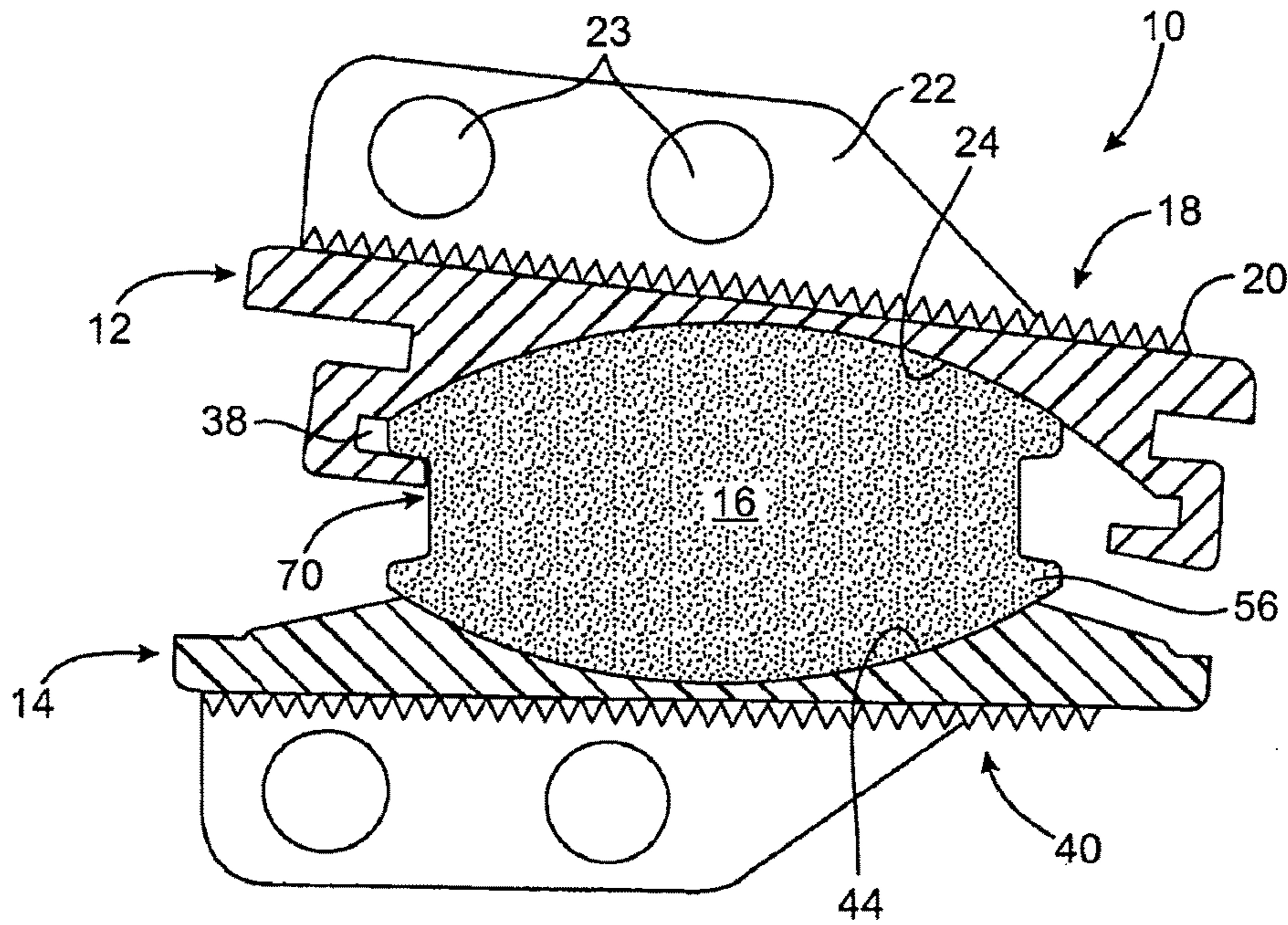

FIG. 3

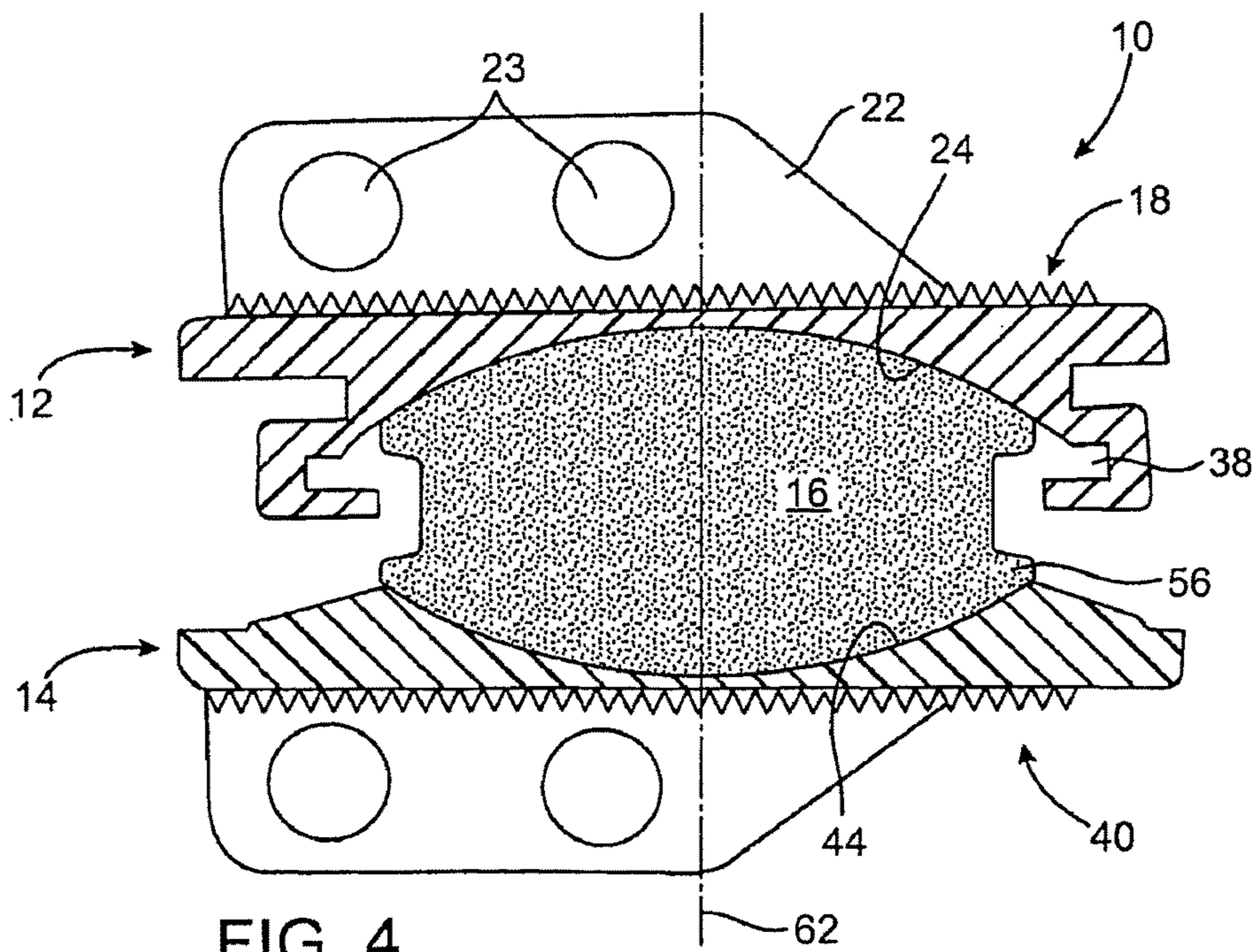

FIG. 4

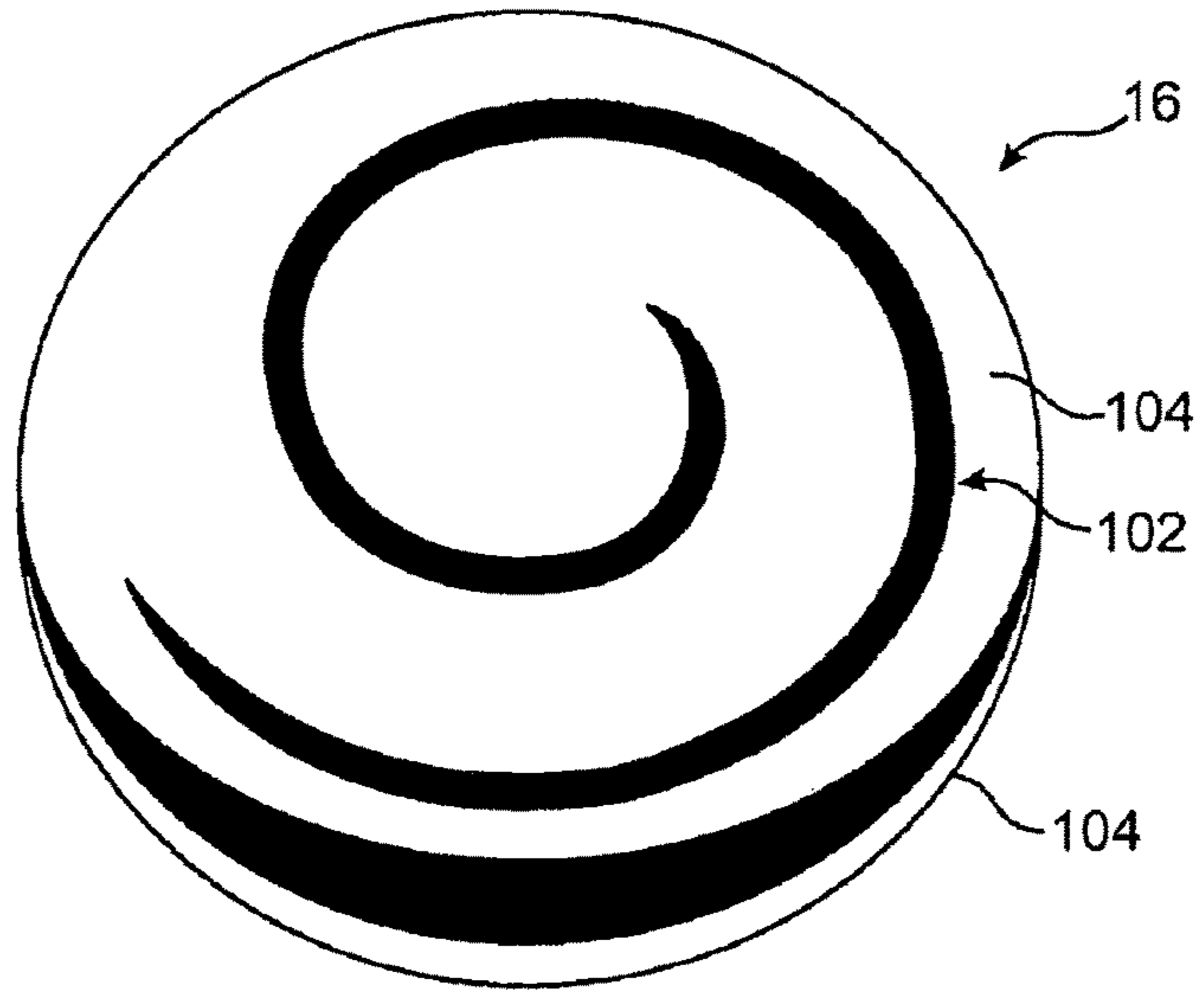

FIG. 5

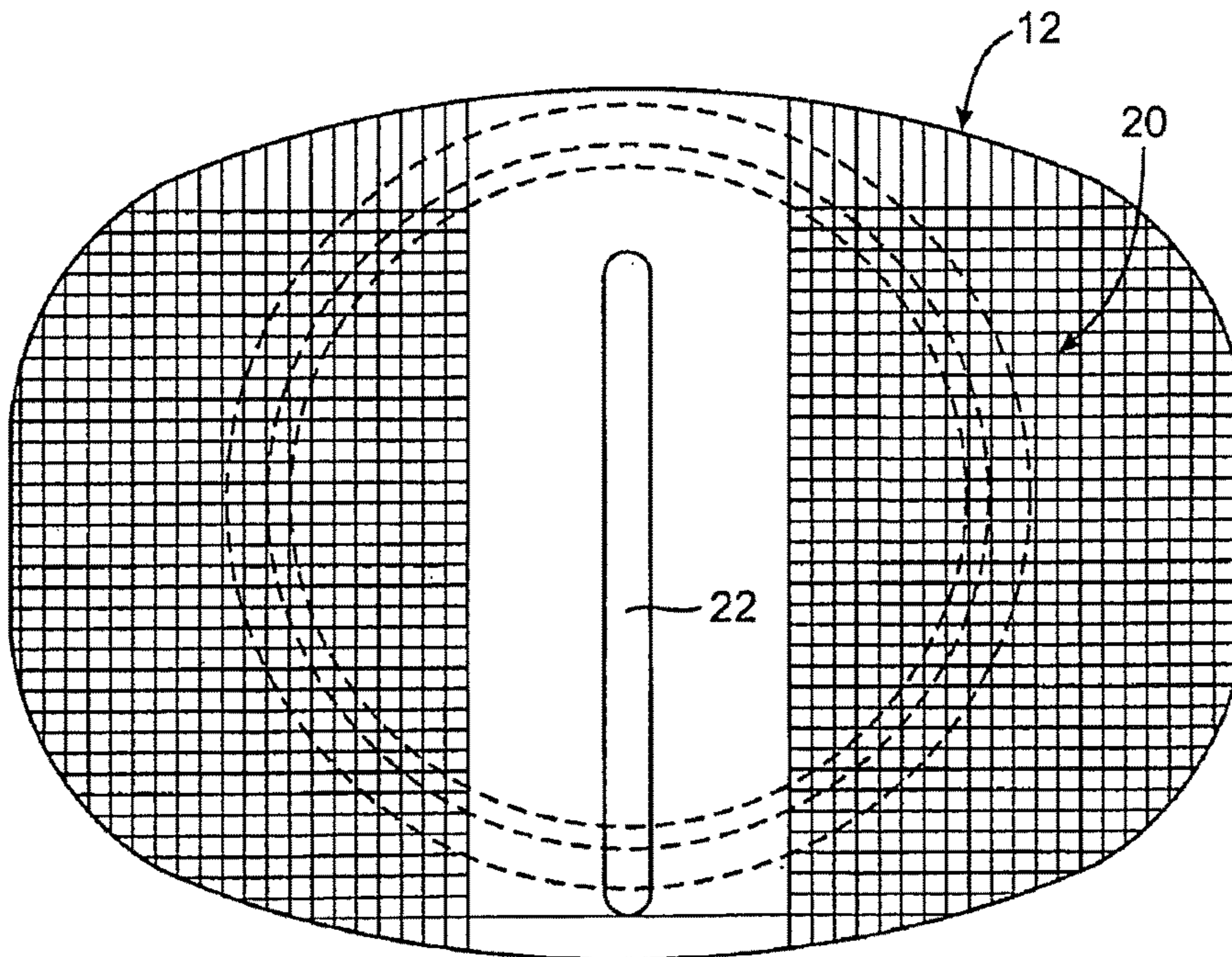

FIG. 6

INTERVERTEBRAL PROSTHETIC DISC WITH METALLIC CORE

Matter enclosed in heavy brackets [] appears in the original patent but forms no part of this reissue specification; matter printed in italics indicates the additions made by reissue; a claim printed with strikethrough indicates that the claim was canceled, disclaimed, or held invalid by a prior post-patent action or proceeding.

CROSS-REFERENCES TO RELATED APPLICATIONS

The present application is a divisional of U.S. Ser. No. 10/903,913 filed Jul. 30, 2004; the full disclosure of which is incorporated herein by reference in its entirety.

The present application is a Continuation-in-Part of U.S. Ser. No. 12/101,664 filed Apr. 11, 2008, which is a Continuation of U.S. Ser. No. 10/855,817 filed May 26, 2004, which claims the priority of U.S. Provisional Application Nos. 60/473,802 and 60/473,803, both of which were filed May 27, 2003.

This application is related to U.S. patent application Ser. Nos. 10/855,253 and 10/855,817, both of which were filed on May 26, 2004, and both of which are hereby incorporated fully by reference.

BACKGROUND OF THE INVENTION

1. Field of the Invention

This invention relates to medical devices and methods. More specifically, the invention relates to intervertebral disc prostheses.

Back pain takes an enormous toll on the health and productivity of people around the world. According to the American Academy of Orthopedic Surgeons, approximately 80 percent of Americans will experience back pain at some time in their life. In just the year 2000, approximately 26 million visits were made to physicians' offices due to back problems in the United States. On any one day, it is estimated that 5% of the working population in America is disabled by back pain.

One common cause of back pain is injury, degeneration and/or dysfunction of one or more intervertebral discs. Intervertebral discs are the soft tissue structures located between each of the thirty-three vertebral bones that make up the vertebral (spinal) column. Essentially, the discs allow the vertebrae to move relative to one another. The vertebral column and discs are vital anatomical structures, in that they form a central axis that supports the head and torso, allow for movement of the back, and protect the spinal cord, which passes through the vertebrae in proximity to the discs.

Discs often become damaged due to wear and tear or acute injury. For example, discs may bulge (herniate), tear, rupture, degenerate or the like. A bulging disc may press against the spinal cord or a nerve exiting the spinal cord, causing "radicular" pain (pain in one or more extremities caused by impingement of a nerve root). Degeneration or other damage to a disc may cause a loss of "disc height," meaning that the natural space between two vertebrae decreases. Decreased disc height may cause a disc to bulge, facet loads to increase, two vertebrae to rub together in an unnatural way and/or increased pressure on certain parts of the vertebrae and/or nerve roots, thus causing pain. In general, chronic and acute damage to intervertebral discs is a common source of back related pain and loss of mobility.

When one or more damaged intervertebral discs cause a patient pain and discomfort, surgery is often required. Traditionally, surgical procedures for treating intervertebral discs have involved discectomy (partial or total removal of a disc), with or without fusion of the two vertebrae adjacent to the disc. Fusion of the two vertebrae is achieved by inserting bone graft material between the two vertebrae such that the two vertebrae and the graft material grow together. Oftentimes, pins, rods, screws, cages and/or the like are inserted between the vertebrae to act as support structures to hold the vertebrae and graft material in place while they permanently fuse together. Although fusion often treats the back pain, it reduces the patient's ability to move, because the back cannot bend or twist at the fused area. In addition, fusion increases stresses at adjacent levels of the spine, potentially accelerating degeneration of these discs.

In an attempt to treat disc related pain without fusion, an alternative approach has been developed, in which a movable, implantable, artificial intervertebral disc (or "disc prosthesis") is inserted between two vertebrae. A number of different intervertebral disc prostheses are currently being developed. For example, the inventors of the present invention have developed disc prostheses described in U.S. patent application Ser. Nos. 10/855,817 and 10/855,253, previously incorporated by reference. Other examples of intervertebral disc prostheses are the LINK SB CHARITE™ disc prosthesis (provided by DePuy Spine, Inc.) the MOBIDISK™ disc prosthesis (provided by LDR Medical), the BRYAN™ cervical disc prosthesis (provided by Medtronic Sofamor Danek, Inc.), the PRODISC™ disc prosthesis or PRODISC-C™ disc prosthesis (from Synthes Stratec, Inc.), and the PCM™ disc prosthesis (provided by Cervitech, Inc.). Although existing disc prostheses provide advantages over traditional treatment methods, improvements are ongoing.

One type of intervertebral disc prosthesis generally includes upper and lower prosthesis plates or shells, which locate against and engage the adjacent vertebral bodies, and a low friction core between the plates. In some designs, the core has upper and lower convexly curved surfaces, and the plates have corresponding, concavely curved recesses which cooperate with the curved surfaces of the core. This allows the plates to slide over the core to allow required spinal movements to take place. Some type of movement limiting structure is provided, to prevent the core from slipping out between the plates. Typically, the plates are made of one or more metals, and the core is made of a polymeric substance.

One of the challenges in designing an intervertebral disc prosthesis is to prevent or reduce wear and tear of the core. In many prosthetic discs, the plates are metallic, and the core is made of a polymeric material. Although a core made of a polymeric or other resilient material may last many years, it would be advantageous to have cores that could last even longer, so that patients (especially younger patients) would not be faced with the possibility of repeat surgeries to replace disc prostheses. At the same time, longer-lasting cores should still allow for a desirable range and ease of motion of the two vertebrae about the intervertebral disc prosthesis.

Therefore, a need exists for improved intervertebral disc prostheses. Ideally, such improved prostheses would provide improved resistance to wear and tear while also allowing a desired amount of vertebral movement about the prosthesis. At least some of these objectives will be met by the present invention.

2. Description of the Background Art

A number of exemplary intervertebral disc prostheses are listed above. Published US patent applications 2002/

0035400A1 and 2002/0128715A1 describe disc implants which comprise opposing plates with a core between them over which the plates can slide. The core receives one or more central posts, which are carried by the plates and which locate in opposite ends of a central opening in the core. Such arrangements limit the load bearing area available between the plates and core.

Other patents related to intervertebral disc prostheses include U.S. Pat. Nos. 4,759,766; 4,863,477; 4,997,432; 5,035,716; 5,071,437; 5,370,697; 5,401,269; 5,507,816; 5,534,030; 5,556,431; 5,674,296; 5,676,702; 5,702,450; 5,824,094; 5,865,846; 5,989,291; 6,001,130; 6,022,376; 6,039,763; 6,139,579; 6,156,067; 6,162,252; 6,315,797; 6,348,071; 6,368,350; 6,416,551; 6,592,624; 6,607,558 and 6,706,068. Other patent applications related to intervertebral disc prostheses include U.S. Patent Application Publication Nos.: 2003/0009224; 2003/0074076; 2003/0191536; 2003/0208271; 2003/0135277; 2003/0199982; 2001/0016773 and 2003/0100951. Other related patents include WO 01/01893A1, EP 1344507, EP 1344506, EP 1250898, EP 1306064, EP 1344508, EP 1344493, EP 1417940, EP 1142544, and EP 0333990.

BRIEF SUMMARY OF THE INVENTION

In one aspect of the present invention, a prosthetic disc for insertion between adjacent vertebrae includes a core having upper and lower curved surfaces and upper and lower plates. At least one of the curved surfaces of the core is composed of or covered by a metal, which forms a metallic portion of the core. Each plate has an outer surface which engages a vertebra and a metallic inner curved surface which is shaped to slide over one of the curved surfaces of the core. The center of rotation of the core is free to move relative to the upper and lower metallic plates. Thus, the plates can slide freely in all directions, not being limited to movement in a single direction as with the prior art. Metal endplates combined with a core having at least one metallic surface will help prevent wear and tear of the disc prosthesis.

“Curved surfaces” of the core and/or the plates typically means that such surfaces are spherical. However, it is also contemplated that other, non-spherical surface shapes may be used, such as but not limited to ovoid, crowned, domed or other complementary surface shapes which provide for the desired freedom of movement of the plates relative to the core. A center of rotation of the core that is free to move relative to the upper and lower plates means that the core is not fixed in an immobile state to either of the plates. Thus, the core may move laterally or “float” relative to the plates, and the plates may move freely over the core.

The upper and lower plates may be made of any suitable metal, metal alloy or combination of metals or alloys. In some embodiments, for example, the plates may be made of cobalt chrome molybdenum, titanium, stainless steel or some combination thereof. In some embodiments, titanium plates are used, and these plates may optionally include inner surfaces of titanium nitride and outer surfaces that are aluminum oxide blasted to create micro-concavities. In another embodiment, cobalt chrome plates are used, with the outer surfaces being blasted with aluminum oxide and then coated with a titanium plasma spray. In some embodiments, the plates comprise an MRI-compatible material, such as titanium, coupled with a hardened material, such as cobalt chrome molybdenum. Such materials may be coupled using any suitable means, such as welding, laminating, slip fitting, interference fitting, adhesion, welding, molding, heating and cooling one material to attach it to another, or the like. Some

plates include a coating or material on the inner surfaces for reducing friction and/or wear and tear, such as a titanium nitride surface.

The metallic portion of the core may also be made of any suitable metal, alloy or combination of metals or alloys. In various embodiments, for example, one curved surface of the core, both curved surfaces of the core, or the entire core may comprise cobalt chrome molybdenum, titanium, stainless steel or some combination thereof. In some embodiments, the core and the upper and lower plates may be made of the same metal, while in alternative embodiments they may be made of different metals. In some embodiments, the core may comprise a combination of metallic and non-metallic substances, such as metal and ceramic, polymer, a combination of polymers, or the like. In such embodiments, the curved surfaces of the core may be laminated or coated in metal, or metallic curved surface portions may be attached to the non-metallic portions. In one embodiment, the core is hollow, with metallic curved surfaces.

The core may have any suitable configuration or shape. In one embodiment, the core comprises two oppositely facing, convex, low-friction, metallic or metal-covered surfaces which slidably engage the inner curved surfaces of the upper and lower plates. One or both of the upper and lower curved surfaces of the core may optionally include at least one channel on the surface(s) for allowing passage or intrusion of bodily fluid to promote lubrication between the core and at least one of the plates. In some embodiments, two or more channels are included on at least one of the core surfaces. Such channels, for example, may be oriented perpendicularly across the upper and/or lower surfaces to intersect. In some embodiments, each of the upper and lower surfaces of the core includes at least one channel. The core may have additional surface features in various embodiments, such as but not limited to threads for screwing into complementary threads on the upper and/or lower plates.

In some embodiments, the present invention further provides restraining structure on one or both of the plates or the core to hold the core against the curved surface of at least one of the plates during sliding movement of the plates over the core. For example, one or more peripheral restraining structures may be included. The peripheral restraining structure defines a limit or boundary for movement of the core relative to at least one of the upper and lower plates. Within such a peripheral boundary, however, movement of the core relative to the plate will preferably be unconstrained. That is, movement of the core relative to the plate may occur in any direction without significant inhibition or friction. The core will preferably not be attached to either the upper or lower plate, and the plates will thus be able to freely articulate relative to each other over the core, which provides a low friction bearing surface for each plate.

An advantage of the structure thus described is that the surface contact area between the core and each of the upper and lower plates may be maximized. By providing only a peripheral restraint, as opposed for example to grooves and keys on the surface of the core and plates, the width or diameter of the core relative to the size of the plate may be maximized. Moreover, the surfaces of the core and the plates which contact each other may be made smooth and free from other structure(s) that might adversely affect performance. In the preferred embodiments, both the curved surfaces of the plates and the corresponding surfaces of the core will be spherical sections. The use of spherical surfaces promotes free, unconstrained relative motion of the plates and the core in all directions.

5

In some embodiments, the peripheral restraining structure limits relative inclination of the plates during sliding movement of the plates over the core, usually by defining a stop structure. In other embodiments, the peripheral restraining structure lifts one side of the core relative to an opposite side of the core during sliding movement of the plates over the core. The peripheral restraining structure itself may take any of a number of different forms. In one embodiment, for example, the restraining structure comprises a ring structure on at least one of the upper and lower plates and an annular structure on at least a portion of the periphery of the core. In one embodiment, the ring structure is adapted to engage and restrain the annular structure on the core. For example, the ring structure may comprise a flange which defines an overhang over at least a portion of the periphery of one of the plates. The overhang of the flange will receive the annular structure on the core to provide an interference fit which retains the core against the curved surface of the plate but allows the core to slide freely and in an unconstrained manner within the limit or boundary defined by the flange. The annular structure on the core may be a rim which extends continuously or discontinuously (preferably continuously) around a lateral circumference of the core. By providing a rim which has a width, usually a diameter, which is slightly greater than the corresponding width of an inner edge of the flange at one point, the core will be held in place and will not be dislodged from the cavity defined by the ring structure in normal use.

In an alternative embodiment, the annular structure on the core may have a width or outer diameter that is slightly smaller than an inner diameter of the ring structure (such as a flange) on the upper or lower plate. Thus, the annular structure on the core may be passed through the ring structure to engage the core with the upper or lower plate. The core is then held in place, relative to the upper or lower plate, via forces applied by the adjacent vertebrae and surrounding soft tissue structures. Essentially, this embodiment is analogous to a ball-and-socket joint. Such an embodiment may be advantageous for ease of assembly of prosthetic disc with a metallic core and metallic endplates.

Usually, the flange or other ring structure as well as the rim or other annular structure will be formed continuously about the periphery of the plate and core, respectively. Alternatively, however, either or both of the annular structure and the ring structure could be formed discontinuously. That is, so long as at least some portion of the ring structure and the annular structure remain engaged during all expected geometries and uses of the prosthetic disc, the objective of holding the core against the curved surface of the plate will be met.

Optionally, in some embodiments the outer surfaces of the upper and lower plates have at least one surface feature for promoting attachment of the outer surfaces to the vertebrae. For example, such surface features may include a plurality of serrations disposed along the outer surfaces. Some embodiments include additional or alternative features on the outer surfaces for enhancing attachment of the prosthesis to vertebral bone, such as a material or coating, like a titanium plasma spray. Multiple micro-concavities may be formed on the outer surfaces, for example by aluminum oxide spraying, to further enhance attachment. Additionally or alternatively, the surface features may include at least one fin disposed on each of the outer surfaces. In some embodiments, the fin includes at least one hole for further promoting attachment to the vertebrae. Fins may extend vertically from their corresponding outer surfaces at right angles, or alternatively the fins may extend from their corresponding

6

outer surface at angles other than 90°. Fins may also have any suitable orientation relative to the anterior-posterior axis of the prosthesis. For example, a fin may extend in a straight line from anterior to posterior, without being angled. Alternatively, the fin may be rotated or angled away from the anterior-posterior axis at any suitable angle between 0° and 180°. In one embodiment, each fin is disposed in a lateral orientation on the outer surfaces.

In another aspect of the present invention, a prosthetic disc for insertion between adjacent vertebrae includes a core having upper and lower curved surfaces, and upper and lower plates. Again, at least one of the curved surfaces of the core is composed of a metal, and in some embodiments the entire core is metallic. Additionally, each of the curved surfaces includes at least one surface channel for allowing passage of bodily fluid to promote lubrication between the core and the plates. Each plate has an outer surface which engages a vertebra and a metallic inner curved surface which is shaped to slide over one of the curved surfaces of the core. In a preferred embodiment, the center of rotation of the core is free to move relative to the upper and lower metallic plates. Any of the features described above may also be incorporated in various embodiments.

In another aspect of the present invention, a prosthetic disc for insertion between adjacent vertebrae includes a metallic core having upper and lower curved surfaces and upper and lower metallic plates. Each plate has an outer surface which engages a vertebra and an inner curved surface which slides over the curved surface of the core. The center of rotation of the core is free to move relative to the upper and lower metallic plates. In some embodiments, the core and the plates are made of the same metal. Some embodiments further include one or more channels on each curved surface of the core, on one or more of the plates, or both, for promoting lubrication.

In another aspect of the present invention, a method for assembling a prosthetic disc for insertion between adjacent vertebrae involves movably coupling a core with a first metallic endplate to form an interference fit between the core and the first endplate and contacting the core with a second metallic endplate. At least one of the curved surfaces of the core is metallic, as described above. In some embodiments, coupling the metallic core with the first metallic endplate involves heating the first endplate sufficiently to cause it to expand, inserting a portion of the core into the expanded endplate restraining structure, and allowing the first endplate to cool, thus contracting to form the interference fit around the portion of the core. In an alternative embodiment, coupling the core with the first endplate comprises forming the endplate around the core. Alternatively, coupling the core with the first endplate may involve screwing the core into the first endplate via complementary threads on the core and the first endplate. In some embodiments, coupling the core with the first endplate may involve engaging a peripheral protrusion of the core with a peripheral restraining structure of the first endplate.

In another aspect of the present invention, a method for implanting an intervertebral disc prosthesis between adjacent vertebrae comprises implanting an upper metallic plate against a lower surface of an upper vertebral body, implanting a lower metallic plate against an upper surface of a lower vertebral body, and disposing a core (at least one curved surface of which is metallic) between the upper and lower plates. The core floats with a mobile center of rotation between spherical cavities in each of the upper and lower plates. In some embodiments, the plates restrain peripheral movement of the core using at least one peripheral restrain-

ing member. In some embodiments, disposing the core between the plates involves passing an annular structure of the core through a ring structure of one of the plates. In some embodiments, implanting each of the plates comprises sliding a fin on each plate into a corresponding groove formed in its respective vertebral body. The fin may slide into the groove in any suitable direction, such as posterior-anterior, anterior-posterior, lateral, or any angled direction between an anterior-posterior orientation and a lateral orientation. Optionally, implanting may further involve contacting textured outer surfaces of the upper and lower plates with the upper and lower surfaces of the vertebral bodies.

These and other aspects and embodiments will be described in further detail below, with reference to the drawing figures.

BRIEF DESCRIPTION OF THE DRAWINGS

FIGS. 1 and 1A are cross-sectional anterior views of a prosthetic disc with the prosthesis plates and core in vertical alignment, according to embodiments of the present invention;

FIG. 2 is a side view of the prosthetic disc in FIG. 1 after sliding movement of the plates over the core;

FIG. 3 is a side view of the prosthetic disc in FIG. 1 after translational movement of the plates relative to the core;

FIG. 4 is a side view of the prosthetic disc in FIG. 1 with the prosthesis plates and core in vertical alignment;

FIG. 5 is a perspective view of a core of a prosthetic disc, according to one embodiment of the present invention; and

FIG. 6 is a superior view of an upper plate of a prosthetic disc, according to one embodiment of the present invention.

DETAILED DESCRIPTION OF THE INVENTION

Various embodiments of the present invention generally provide for an intervertebral disc prosthesis having upper and lower plates and a core having at least one metallic surface. In various embodiments, the core may have a mobile center of rotation, one or more surface channels for promoting passage of lubricating fluid, or both. FIGS. 1-6 generally demonstrate one embodiment of such a prosthesis. The general principles of the present invention, however, may be applied to any of a number of other disc prostheses, such as but not limited to the LINK SB CHARITE™ disc prosthesis (provided by DePuy Spine, Inc.) the MOBIDISK™ disc prosthesis (provided by LDR Medical), the BRYAN™ cervical disc prosthesis (provided by Medtronic Sofamor Danek, Inc.), the PRODISC™ disc prosthesis or PRODISC-C™ disc prosthesis (from Synthes Stratec, Inc.), and the PCM™ disc prosthesis (provided by Cervitech, Inc.).

That being said, and with reference now to FIGS. 1-4 a prosthetic disc 10 for intervertebral insertion between two adjacent spinal vertebrae (not shown) suitably includes an upper plate 12, a lower plate 14 and a core 16 located between the plates. The upper plate 12 includes an outer surface 18 and an inner surface 24 and may be constructed from any suitable metal, alloy or combination of metals or alloys, such as but not limited to cobalt chrome molybdenum, titanium (such as grade 5 titanium), stainless steel and/or the like. In one embodiment, typically used in the lumbar spine, the upper plate 12 is constructed of cobalt chrome molybdenum, and the outer surface 18 is treated with aluminum oxide blasting followed by a titanium plasma spray. In another embodiment, typically used in the cervical

spine, the upper plate 12 is constructed of titanium, the inner surface 24 is coated with titanium nitride, and the outer surface 18 is treated with aluminum oxide blasting. An alternative cervical spine embodiment includes no coating on the inner surface 24. In other cervical and lumbar disc embodiments, any other suitable metals or combinations of metals may be used. In some embodiments, it may be useful to couple two materials together to form the inner surface 24 and the outer surface 18. For example, the upper plate 12 may be made of an MRI-compatible material, such as titanium, but may include a harder material, such as cobalt chrome molybdenum, for the inner surface 24. Any suitable technique may be used to couple materials together, such as snap fitting, slip fitting, lamination, interference fitting, use of adhesives, welding and/or the like. Any other suitable combination of materials and coatings may be employed in various embodiments of the invention.

In some embodiments, the outer surface 18 is planar. Oftentimes, the outer surface 18 will include one or more surface features and/or materials to enhance attachment of the prosthesis 10 to vertebral bone. For example, the outer surface 18 may be machined to have serrations 20 or other surface features for promoting adhesion of the upper plate 12 to a vertebra. In the embodiment shown (seen best in FIG. 6), the serrations 20 extend in mutually orthogonal directions, but other geometries would also be useful. Additionally, the outer surface 18 may be provided with a rough microfinish formed by blasting with aluminum oxide microparticles or the like. In some embodiments, the outer surface may also be titanium plasma sprayed to further enhance attachment of the outer surface 18 to vertebral bone.

The outer surface 18 may also carry an upstanding, vertical fin 22 extending in an anterior-posterior direction. The fin 22 is pierced by transverse holes 23. In alternative embodiments, the fin 22 may be rotated away from the anterior-posterior axis, such as in a lateral-lateral orientation, a posterolateral-anterolateral orientation, or the like. In some embodiments, the fin 22 may extend from the surface 18 at an angle other than 90°. Furthermore, multiple fins 22 may be attached to the surface 18 and/or the fin 22 may have any other suitable configuration, in various embodiments. In other embodiments, the fin 22 In some embodiments, such as discs 10 for cervical insertion, the fins 22, 42 may be omitted altogether.

The inner, spherically curved concave surface 24 is formed at a central (from right to left), axial position with a circular recess 26 as illustrated. At the outer edge of the curved surface 24, the upper plate 12 carries peripheral restraining structure comprising an integral ring structure 26 including an inwardly directed rib or flange 28. The flange 28 forms part of a U-shaped member 30 joined to the major part of the plate by an annular web 32. The flange 28 has an inwardly tapering shape and defines upper and lower surfaces 34 and 36 respectively which are inclined slightly relative to the horizontal when the upper plate 12 is at the orientation seen in FIG. 1. An overhang 38 of the U-shaped member 30 has a vertical dimension that tapers inwardly as illustrated.

The lower plate 14 is similar to the upper plate 12 except for the absence of the peripheral restraining structure 26. Thus, the lower plate 14 has an outer surface 40 which is planar, serrated and microfinished like the outer surface 18 of the upper plate 12. The lower plate 14 optionally carries a fin 42 similar to the fin 22 of the upper plate. The inner surface 44 of the lower plate 14 is concavely, spherically curved with a radius of curvature matching that of the inner

surface 24 of the upper plate 12. Once again, this surface may be provided with a titanium nitride or other finish.

At the outer edge of the inner curved surface 44, the lower plate 14 is provided with an inclined ledge formation 46. Alternatively, the lower plate 14 may include peripheral restraining structure analogous to the peripheral restraining structure 26 on the upper plate 12.

The core 16 of the disc 10 is at least partially made of one or more metals, alloys or a combination of metals or alloys. For example, metals used to form all or part of the core 16 may include but are not limited to cobalt chrome molybdenum, titanium (such as grade 5 titanium), stainless steel and/or the like. In some embodiments, the core 16 may be made of the same material as the upper plate 12 and the lower plate 14, which may help resist oxidation of metallic surfaces of the disc 10. In alternative embodiments, the core 16 may be made of different material(s) than the plates 12, 14. In the embodiment shown, the core 16 has identical upper and lower spherically curved convex surfaces 48, 50. At least one of the curved surfaces 48, 50 is metallic or covered in metal. In some embodiments, the entire core 16 is metallic, while in other embodiments the curved surfaces 48, 50 may be coated or laminated with metal, or one or more metallic surfaces may be otherwise attached to the core 16. In some embodiments, the core 16 is made of a polymer or ceramic, with attached metallic curved surfaces 48, 50. Alternatively, the core 16 may be a hollow metallic structure. The radius of curvature of these surfaces matches the radius of curvature of the inner surfaces 24, 44 of the upper and lower plates 12, 14. The curved surfaces are accordingly complementary.

The core 16 is symmetrical about a central, equatorial plane 52 which bisects it laterally. (Although in other embodiments, the core 16 may be asymmetrical.) Lying on this equatorial plane is an annular recess or groove 54 which extends about the periphery of the core. The groove 54 is defined between upper and lower ribs or lips 56. When the plates 12, 14 and core 16 are assembled and in the orientation seen in FIG. 1, the flange 28 lies on the equatorial plane and directly aligned with the groove 54. The outer diameter 58 of the lips 56 is preferably very slightly larger than the diameter 60 defined by the inner edge of the flange 28. In some embodiments, the core 16 is movably fitted into the upper plate 12 via an interference fit. To form such an interference fit with a metal core 16 and metal plate 12, any suitable techniques may be used. For example, the plate 12 may be heated so that it expands, and the core 16 may be dropped into the plate 12 in the expanded state. When the plate 12 cools and contracts, the interference fit is created. In another embodiment, the upper plate 12 may be formed around the core 16. Alternatively, the core 16 and upper plate 12 may include complementary threads 59, 61 as shown in FIG. 1A, which allow the core 16 to be screwed into the upper plate 12, where it can then freely move.

In an alternative embodiment (not shown), the outer diameter 58 of the lips 56 may be very slightly smaller than the diameter 60 defined by the inner edge of the flange 28. In such embodiments, the core 16 and the plates 12, 14 are not coupled via an interference fit but are instead coupled via forces applied by the vertebral column itself, thus acting analogously to a ball-and-socket joint.

Referring now to FIG. 5, in some embodiments, the core 16 includes one or more surface channels 102 for allowing passage of fluid along the contact surfaces 104 of the core 16. Bodily fluids and/or injected fluid may pass through such a channel 102, between the core 16 and the upper and lower plates 12, 14, to promote lubrication between the contact

surfaces 104 of the core and their corresponding surfaces on the upper and lower plates 12, 14. Any number, pattern, shape, depth, width or length of surface channels 102 may be included on a contact surface 104, in various embodiments. In some embodiments, for example, channels 102 may have a depth of about 3 mm or less, and more preferably about 2 mm or less, and even more preferably about 1 mm or less. Surface channels 102 may have a cross-sectional shape that is curved, rectangular, V-shaped or any other suitable shaped. Furthermore, surface channels 102 may be disposed on the contact surface(s) 104 of the core 16 in a helical pattern (as shown) or in any other suitable pattern, such as circular, rectangular, curved, one or more straight, parallel lines, two or more perpendicular lines, or the like. Surface channels 102 help prevent sticking or loss of freedom of motion (seizing) between the core 16 and the plates 12, 14 which may occur otherwise due to metal-on-metal contact.

In some embodiments, one or both of the inner surfaces 24, 44 of the upper and lower plates 12, 14 may also include one or more surface channels 25, 45 as shown in FIG. 1. Again, such channels may have any suitable configuration, size, number and shape, and may assist in promoting lubrication between the core 16 and the upper and lower plates 12, 14.

The central axis of the disc 10 (the axis passing through the centers of curvature of the curved surfaces) is indicated with the reference numeral 62. As shown in FIG. 1, the disc 10 may be symmetrical about a central anterior-posterior plane containing the axis 62. Referring to FIG. 4, in some embodiments the axis 62 is posteriorly disposed, i.e. is located closer to the posterior limit of the disc than the anterior limit thereof.

In use, the disc 10 is surgically implanted between adjacent spinal vertebrae in place of a damaged disc. The adjacent vertebrae are forcibly separated from one another to provide the necessary space for insertion. The disc is inserted, normally in a posterior direction, into place between the vertebrae with the fins 22, 42 of the plates 12, 14 entering slots cut in the opposing vertebral surfaces to receive them. During and/or after insertion, the vertebrae, facets, adjacent ligaments and soft tissues are allowed to move together to hold the disc in place. The serrated and microfinished surfaces 18, 40 of the plates 12, 14 locate against the opposing vertebrae. The serrations 20 and fins 22, 42 provide initial stability and fixation for the disc 10. With passage of time, enhanced by the titanium surface coating, firm connection between the plates and the vertebrae will be achieved as bone tissue grows over the serrated surface. Bone tissue growth will also take place about the fins 22, 40 and through the transverse holes 23 therein, further enhancing the connection which is achieved.

In the assembled disc 10, the complementary and cooperating spherical surfaces of the plates and core allow the plates to slide or articulate over the core through a fairly large range of angles and in all directions or degrees of freedom, including rotation about the central axis 62. FIGS. 1 and 4 show the disc 10 with the plates 12 and 14 and core 16 aligned vertically with one another on the axis 62. FIG. 2 illustrates a situation where maximum anterior flexion of the disc 10 has taken place. At this position, the upper rib 56 has entered the hollow 38 of the U-shaped member 30, the lower surface of the rib 56 has moved into contact with the upper surface 34 of the flange 28, the flange having moved into the groove 54, and the lower surface 36 of the flange has moved into contact with the upper surface of the ledge formation 46, as will be seen in the encircled areas 69.

11

Abutment between the various surfaces prevents further anterior flexure. The design also allows for the inner extremity of the flange 28 to abut against the base of the groove 54, thereby limiting further relative movement between the core and plate. A similar configuration is achieved in the event of maximum posterior flexure of the plates 12, 14 over the core, such as during spinal extension and/or in the event of maximum lateral flexure.

FIG. 3 illustrates how the disc 10 can also allow for translational movement of the plates relative to the core. In the illustrated situation there has been lateral translation of the plates relative to the core. The limit of lateral translation is reached when the inner extremity of the flange 28 abuts the base of the groove 54 as indicated by the numeral 70.

The flange 28 and the groove 54 defined between the ribs 56, prevent separation of the core from the plates. In other words, the cooperation of the retaining formations ensures that the core is held captive between the plates at all times during flexure of the disc 10.

In an alternative embodiment, the continuous annular flange 28 may be replaced by a retaining formation comprising a number of flange segments which are spaced apart circumferentially. Such an embodiment could include a single, continuous groove 54 as in the illustrated embodiment. Alternatively, a corresponding number of groove-like recesses spaced apart around the periphery of the core could be used, with each flange segment opposing one of the recesses. In another embodiment, the continuous flange or the plurality of flange segments could be replaced by inwardly directed pegs or pins carried by the upper plate 12. This embodiment could include a single, continuous groove 54 or a series of circumferentially spaced recesses with each pin or peg opposing a recess.

In yet another embodiment, the retaining formation(s) could be carried by the lower plate 14 instead of the upper plate, i.e. the plates are reversed. In some embodiments, the upper (or lower) plate is formed with an inwardly facing groove, or circumferentially spaced groove segments, at the edge of its inner, curved surface, and the outer periphery of the core is formed with an outwardly facing flange or with circumferentially spaced flange segments.

Although the foregoing is a complete and accurate description of the invention, any of a number of modifications, additions or the like may be made to the various embodiments without departing from the scope of the invention. Therefore, nothing described above should be interpreted as limiting the scope of the invention at it is described in the claims.

What is claimed is:

1. A method for assembling a prosthetic disc for insertion between adjacent vertebrae, the method comprising:

providing a core with at least one curved surface;

movably coupling [a] the core with a first metallic endplate to form an interference fit between the core and the first metallic endplate, wherein each of the at least one curved [surface] surfaces of the core comprises a metal, wherein coupling the core with the first metallic endplate comprises:

heating the first endplate sufficiently to cause it to expand;

contacting a portion of the core with the expanded endplate; and

allowing the first endplate to cool, thus contracting to form the interference fit around the portion of the core; and

contacting the core with a second metallic endplate.

12

~~2. A method as in claim 1, wherein coupling the core with the first metallic endplate comprises:~~

~~heating the first endplate sufficiently to cause it to expand; contacting a portion of the core with the expanded endplate; and~~

~~allowing the first endplate to cool, thus contracting to form the interference fit around the portion of the core.~~

~~3. A method as in claim 1, wherein coupling the core with the first endplate comprises forming the endplate around the core.~~

~~4. A method as in claim 1, wherein coupling the core with the first endplate comprises engaging a peripheral protrusion of the core with a peripheral restraining structure of the first endplate.~~

5. A method [as in claim 1,] for assembling a prosthetic disc for insertion between adjacent vertebrae, the method comprising:

providing a core with at least one curved surface;

movably coupling the core with a first metallic endplate to form an interference fit between the core and the first metallic endplate, wherein each of the at least one curved surfaces of the core comprises a metal, wherein coupling the core with the first endplate comprises screwing the core into the first endplate via complementary threads on the core and the first endplate; and contacting the core with a second metallic endplate.

6. A method for assembling a prosthetic disc for insertion between adjacent vertebrae, the method comprising:

providing a first metallic endplate having a first bearing surface;

movably coupling a core with the first metallic endplate to form an interference fit between the core and the first metallic endplate, wherein a bearing surface of the core corresponds to a shape of the first bearing surface, wherein the core has circumferentially spaced recesses and at least one of the first or second plates has a plurality of pins or pegs opposing corresponding recesses of the core; and

contacting the core with a second metallic endplate.

7. A method [as in claim 6,] for assembling a prosthetic disc for insertion between adjacent vertebrae, the method comprising:

providing a first metallic endplate having a first bearing surface;

movably coupling a core with the first metallic endplate to form an interference fit between the core and the first metallic endplate, wherein a bearing surface of the core corresponds to a shape of the first bearing surface, wherein coupling the core with the first metallic endplate comprises:

heating the first endplate sufficiently to cause it to expand; contacting a portion of the core with the expanded endplate; and

allowing the first endplate to cool, thus contracting to form the interference fit around the portion of the core; and

contacting the core with a second metallic endplate.

8. A method as in claim 6, wherein coupling the core with the first endplate comprises forming the endplate around the core.

9. A method as in claim [6] 15, wherein coupling the core with the first endplate comprises engaging a peripheral protrusion of the core with [a] the projecting [restraining] structure [of the first endplate], wherein the projecting [restraining] structure engages and retains the peripheral protrusion.

13

10. A method [as in claim 6,] for assembling a prosthetic disc for insertion between adjacent vertebrae, the method comprising:

providing a first metallic endplate having a first bearing surface;

movably coupling a core with the first metallic endplate to form an interference fit between the core and the first metallic endplate, wherein a bearing surface of the core corresponds to a shape of the first bearing surface, wherein coupling the core with the first endplate comprises screwing the core into the first endplate via complementary threads on the core and the first endplate; and

contacting the core with a second metallic endplate.

11. A method for assembling a prosthetic disc for insertion between adjacent vertebrae, the method comprising:

providing a first metallic endplate having a first bearing surface;

movably coupling a core with the first metallic endplate to form an interference fit between the core and the first metallic endplate, wherein a bearing surface of the core corresponds to a shape of the first bearing surface, wherein coupling the core with the first metallic endplate comprises passing outwardly facing surfaces of a peripheral structure on the core through opposing inwardly facing surfaces of a projecting structure on at least one of the first or second metallic plates, and wherein a distance between the outwardly facing surfaces of the peripheral structure on the core is less than a distance between the opposing inwardly facing surfaces of the projecting structure so that the peripheral structure on the core will pass through the projecting structure to restrain peripheral movement of the core; and

contacting the core with a second metallic endplate.

12. A method as in claim 11, wherein the interference fit retains the core against the first bearing surface of the first

14

metallic plate but allows the core to slide freely within a limit defined by the projecting structure.

13. A method as in claim 11, wherein the projecting structure comprises a pin or peg projecting from at least one of the first or second metallic plates.

14. A method as in claim 11, wherein: the projecting structure projects from the first or second plate by a distance;

the bearing surface of the core that corresponds to the shape of the first bearing surface of the first metallic plate is a first core bearing surface;

the core further comprises a second core bearing surface configured to engage the second metallic plate; and

a central region of the first core bearing surface is separated from a central region of the second core bearing surface by a core thickness greater than the distance that the projecting structure projects from the first or second metallic plate.

15. A method for assembling a prosthetic disc for insertion between adjacent vertebrae, the method comprising:

providing a first metallic endplate having a first bearing surface;

movably coupling a core with the first metallic endplate to form an interference fit between the core and the first metallic endplate, wherein a bearing surface of the core corresponds to a shape of the first bearing surface, wherein the interference fit retains the core against the first bearing surface of the first metallic plate but allows the core to slide freely within a limit defined by a projecting structure; and

contacting the core with a second metallic endplate.

16. A method as in claim 15, wherein the projecting structure comprises a pin or peg projecting from at least one of the first or second metallic plates.

* * * * *