

US00RE46725E

(19) **United States**
 (12) **Reissued Patent**
Case et al.

(10) **Patent Number: US RE46,725 E**
 (45) **Date of Reissued Patent: Feb. 20, 2018**

(54) **ELECTRIC OR NATURAL GAS FIRED
 SMALL FOOTPRINT FRACTURING FLUID
 BLENDING AND PUMPING EQUIPMENT**

(71) Applicant: **Halliburton Energy Services, Inc.**,
 Houston, TX (US)

(72) Inventors: **Leonard R. Case**, Duncan, OK (US);
Ed B. Hagan, Hastings, OK (US);
Calvin L. Stegemoeller, Duncan, OK
 (US); **Ron Hyden**, Spring, TX (US)

(73) Assignee: **Halliburton Energy Services, Inc.**,
 Houston, TX (US)

(21) Appl. No.: **15/079,027**

(22) Filed: **Mar. 23, 2016**

Related U.S. Patent Documents

Reissue of:

(64) Patent No.: **8,834,012**
 Issued: **Sep. 16, 2014**
 Appl. No.: **12/774,959**
 Filed: **May 6, 2010**

U.S. Applications:

(63) Continuation-in-part of application No. 12/557,730,
 filed on Sep. 11, 2009, now Pat. No. 8,444,312.

(51) **Int. Cl.**
B01F 5/10 (2006.01)
E21B 21/06 (2006.01)

(52) **U.S. Cl.**
 CPC **E21B 21/062** (2013.01)

(58) **Field of Classification Search**
 None
 See application file for complete search history.

(56) **References Cited**

U.S. PATENT DOCUMENTS

548,793 A	10/1895	Winship	
1,730,173 A	10/1929	Stearns	
2,795,403 A	6/1957	Mead	
2,821,854 A	2/1958	Franke	73/296
3,155,248 A	11/1964	Haller	214/38
3,259,190 A	7/1966	Parsons	
3,279,550 A	10/1966	Kersten	177/136
3,291,234 A	12/1966	Woodburn	177/36
3,381,943 A	5/1968	Miller	
3,547,291 A	12/1970	Batterton et al.	214/515
3,587,760 A	6/1971	Othmar et al.	
3,591,147 A	7/1971	Anderson et al.	259/154
3,687,319 A	8/1972	Adam et al.	214/501
3,792,790 A	2/1974	Brubaker	214/501
3,854,540 A	12/1974	Holmstrom, Jr.	177/136
3,857,452 A	12/1974	Hartman	177/139
3,893,655 A	7/1975	Sandiford	
3,931,999 A	1/1976	McCain	
3,934,739 A	1/1976	Zumsteg et al.	214/501
3,962,877 A	6/1976	Schiemichen	
4,063,605 A	12/1977	Graham	177/225
4,103,752 A	8/1978	Schmidt	177/141
4,163,626 A	8/1979	Batterton et al.	414/469
4,187,047 A	2/1980	Squifflet	414/332
4,249,838 A	2/1981	Harvey et al.	
4,345,628 A	8/1982	Campbell et al.	141/83
4,345,872 A	8/1982	Arnold	414/705

4,411,327 A	10/1983	Lockery et al.	177/211
4,465,420 A	8/1984	Dillman	414/332
4,621,972 A	11/1986	Grotte	414/477
4,634,335 A	1/1987	Van Den Pol	414/494
4,708,569 A	11/1987	Nijenhuis	414/332
4,726,435 A	2/1988	Kitagawa et al.	177/187
4,730,118 A	3/1988	Quarles et al.	
4,775,275 A	10/1988	Perry	414/21
4,819,750 A	4/1989	Carnevale	177/256
4,844,189 A	7/1989	Shisgal et al.	177/211
4,850,750 A	7/1989	Cogbill et al.	
4,854,714 A *	8/1989	Davis	B01F 13/0035 366/132
4,913,198 A	4/1990	Hayahara et al.	141/83

(Continued)

FOREIGN PATENT DOCUMENTS

DE	37 17 417 A1	12/1988
DE	295 18 215 U1	5/1996

(Continued)

OTHER PUBLICATIONS

International Search Report in PCT/GB2010/001717, dated May 10, 2011.

Office Action in U.S. Appl. No. 12/182,297, dated Apr. 21, 2011.

International Search Report for Application No. PCT/GB2010/000512, dated Jun. 25, 2010.

Office Action issued in U.S. Appl. No. 12/235,270, dated Mar. 4, 2011.

Office Action in U.S. Appl. No. 12/422,450, dated Jun. 18, 2010.

Office Action in U.S. Appl. No. 12/435,551, dated Jun. 15, 2011.

Office Action in U.S. Appl. No. 12/635,009, dated Jul. 23, 2012.

Office Action in U.S. Appl. No. 11/741,509, dated Aug. 19, 2009.

Office Action in U.S. Appl. No. 11/741,509, dated Jan. 28, 2010.

Office Action in U.S. Appl. No. 11/930,756, dated Mar. 18, 2009.

Office Action in U.S. Appl. No. 11/930,756, dated Jul. 7, 2009.

(Continued)

Primary Examiner — Ling Xu

(74) *Attorney, Agent, or Firm* — John W. Wustenberg;
 Baker Botts L.L.P.

(57) **ABSTRACT**

Methods and systems for integral storage and blending of the materials used in oilfield operations are disclosed. A modular integrated material blending and storage system includes a first module comprising a storage unit, a second module comprising a liquid additive storage unit and a pump for maintaining pressure at an outlet of the liquid additive storage unit. The system further includes a third module comprising a pre-gel blender. An output of each of the first module, the second module and the third module is located above a blender and gravity directs the contents of the first module, the second module and the third module to the blender. The system also includes a pump that directs the output of the blender to a desired down hole location. The pump may be powered by natural gas or electricity.

94 Claims, 6 Drawing Sheets

(56)

References Cited

U.S. PATENT DOCUMENTS

5,044,861 A 9/1991 Kirchhoff et al. 414/332
 5,127,450 A 7/1992 Saatkamp 141/9
 5,133,212 A 7/1992 Grills et al. 73/296
 5,161,628 A 11/1992 Wirth 177/137
 5,205,370 A 4/1993 Paul et al. 177/256
 5,318,382 A 6/1994 Cahill
 5,333,695 A 8/1994 Walter 172/272
 5,343,000 A 8/1994 Griffen et al. 177/145
 5,452,615 A 9/1995 Hilton 73/862.043
 5,452,954 A 9/1995 Handke et al.
 5,546,683 A 8/1996 Clark 37/468
 5,578,798 A 11/1996 Nuyts 177/136
 5,635,680 A 6/1997 Dojan 177/136
 5,637,837 A 6/1997 Merz et al. 177/145
 5,665,910 A 9/1997 Knutson et al. 73/200
 5,717,167 A 2/1998 Filing et al. 177/136
 5,752,768 A 5/1998 Assh 366/3
 5,764,522 A 6/1998 Shalev 700/240
 5,769,058 A * 6/1998 Scogin F01M 3/00
 123/196 M
 5,811,737 A 9/1998 Gaiski 177/1
 5,811,738 A 9/1998 Boyovich et al. 177/136
 5,850,757 A 12/1998 Wierenga 73/296
 5,880,410 A 3/1999 Neuman 177/187
 5,884,232 A 3/1999 Buder 702/42
 5,981,446 A 11/1999 Qiu et al.
 6,118,083 A 9/2000 Boyovich et al. 177/136
 6,148,667 A 11/2000 Johnson 73/296
 6,186,657 B1 2/2001 Fuchsbichler
 6,242,701 B1 6/2001 Breed et al. 177/144
 6,284,987 B1 9/2001 Al-Modiny 177/170
 6,313,414 B1 11/2001 Campbell 177/16
 6,384,349 B1 5/2002 Voll 177/25.19
 6,414,455 B1 7/2002 Watson
 6,474,926 B2 11/2002 Weiss 414/332
 6,495,774 B1 12/2002 Pederson 177/136
 6,532,830 B1 3/2003 Jansen et al. 73/862.042
 6,601,763 B1 8/2003 Hoch et al. 235/385
 6,769,315 B2 8/2004 Stevenson et al. 73/862.629
 6,928,886 B2 8/2005 Meusel et al. 73/862.324
 6,948,535 B2 9/2005 Stegemoeller
 7,048,432 B2 5/2006 Phillippi et al.
 7,114,322 B2 10/2006 Yamanaka et al.
 7,202,425 B2 4/2007 Knudsen et al. 177/211
 7,214,028 B2 5/2007 Boasso et al. 414/812
 7,214,892 B2 5/2007 Williamson 177/170
 7,240,549 B2 7/2007 Kimbara et al. 73/296
 7,267,001 B1 9/2007 Stein 73/296
 7,353,875 B2 4/2008 Stephenson et al.
 7,472,542 B2 1/2009 Yamanaka et al.
 7,528,329 B2 5/2009 Nuyts 177/136
 8,444,312 B2 * 5/2013 Hagan et al. 366/141
 2001/0038018 A1 11/2001 Bell et al. 222/58
 2003/0047387 A1 3/2003 Bogat 186/59
 2003/0047603 A1 3/2003 Lustenberger et al. 235/385
 2003/0117890 A1 6/2003 Dearing et al.

2003/0202869 A1 10/2003 Posch 414/498
 2005/0110648 A1 5/2005 Lehrman et al. 340/686.1
 2005/0155667 A1 7/2005 Stegemoeller
 2006/0225924 A1 10/2006 Ivan et al. 175/66
 2007/0107540 A1 5/2007 Davies 73/866
 2007/0120367 A1 5/2007 Scherzer
 2007/0125543 A1 6/2007 McNeel et al.
 2007/0201305 A1 8/2007 Heilman et al. E21B 21/062
 366/141
 2007/0277982 A1 12/2007 Shampine et al.
 2008/0029267 A1 2/2008 Shampine et al.
 2008/0066911 A1 3/2008 Luharuka et al.
 2008/0135238 A1 6/2008 Cugnet et al.
 2008/0165613 A1 7/2008 Dykstra
 2008/0173480 A1 7/2008 Annaiyappa et al.
 2008/0203734 A1 8/2008 Grimes et al.
 2008/0238101 A1 10/2008 Ziegenfuss
 2008/0264625 A1 10/2008 Ochoa
 2008/0264641 A1 10/2008 Slabaugh et al.
 2008/0271927 A1 11/2008 Crain 177/1
 2009/0068031 A1 3/2009 Gambier et al.
 2009/0090504 A1 4/2009 Weightman
 2009/0107734 A1 4/2009 Lucas 177/25.11
 2009/0178387 A1 7/2009 Schultz et al.
 2009/0301725 A1 12/2009 Case et al.
 2010/0038907 A1 2/2010 Hunt et al.
 2010/0071284 A1 3/2010 Hagan et al.

FOREIGN PATENT DOCUMENTS

EP A 0 605 113 A1 7/1994
 FR 2474335 7/1981 B01F 3/12
 WO WO 1994/019263 9/1994
 WO WO 2007/113528 A1 10/2007
 WO WO 2009/065858 5/2009 E21B 21/06

OTHER PUBLICATIONS

Office Action in U.S. Appl. No. 11/930,756, dated Jan. 28, 2010.
 Advisory Action in U.S. Appl. No. 11/930,756, dated Mar. 31, 2010.
 Office Action from U.S. Appl. No. 11/930,756, dated May 27, 2010.
 International Search Report and Written Opinion issued in PCT/GB2011/000678 dated Oct. 12, 2012.
 International Preliminary Report on Patentability in PCT/GB2009/001675 dated Feb. 1, 2011.
 Office Action issued in Canadian Application No. 2, 731, 840 dated Jul. 25, 2012.
 Boerger pump—available at: http://www.boerger-pumps.com/contero/gallery/Prospekte_USA/us_p_ssr_boerger_powerfeed_0309.pdf.
 Fenna et al., "Dictionary of Weights, Measures, and Units," Oxford University Press, 2002, pp. I, 65 and 66, 2002.
 Kutz et al., "Mechanical Engineers' Handbook," 2nd Ed., 1998, pp. I, II, and 1332, 1998.
 Abulnaga, "Slurry Systems Handbook," 2002, pp. I, II, and 1.20, 2002.

* cited by examiner

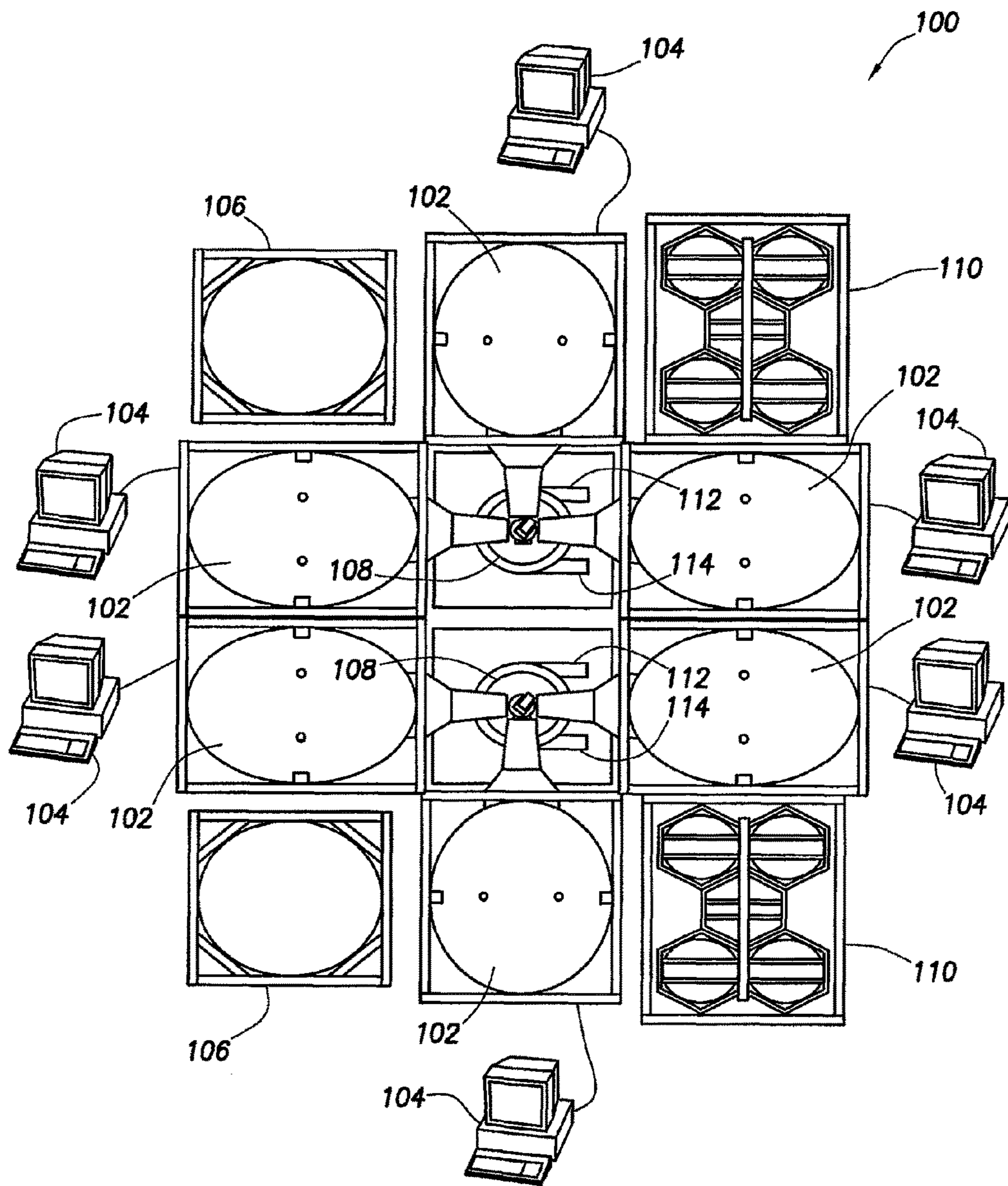

FIG. 1

FIG.2

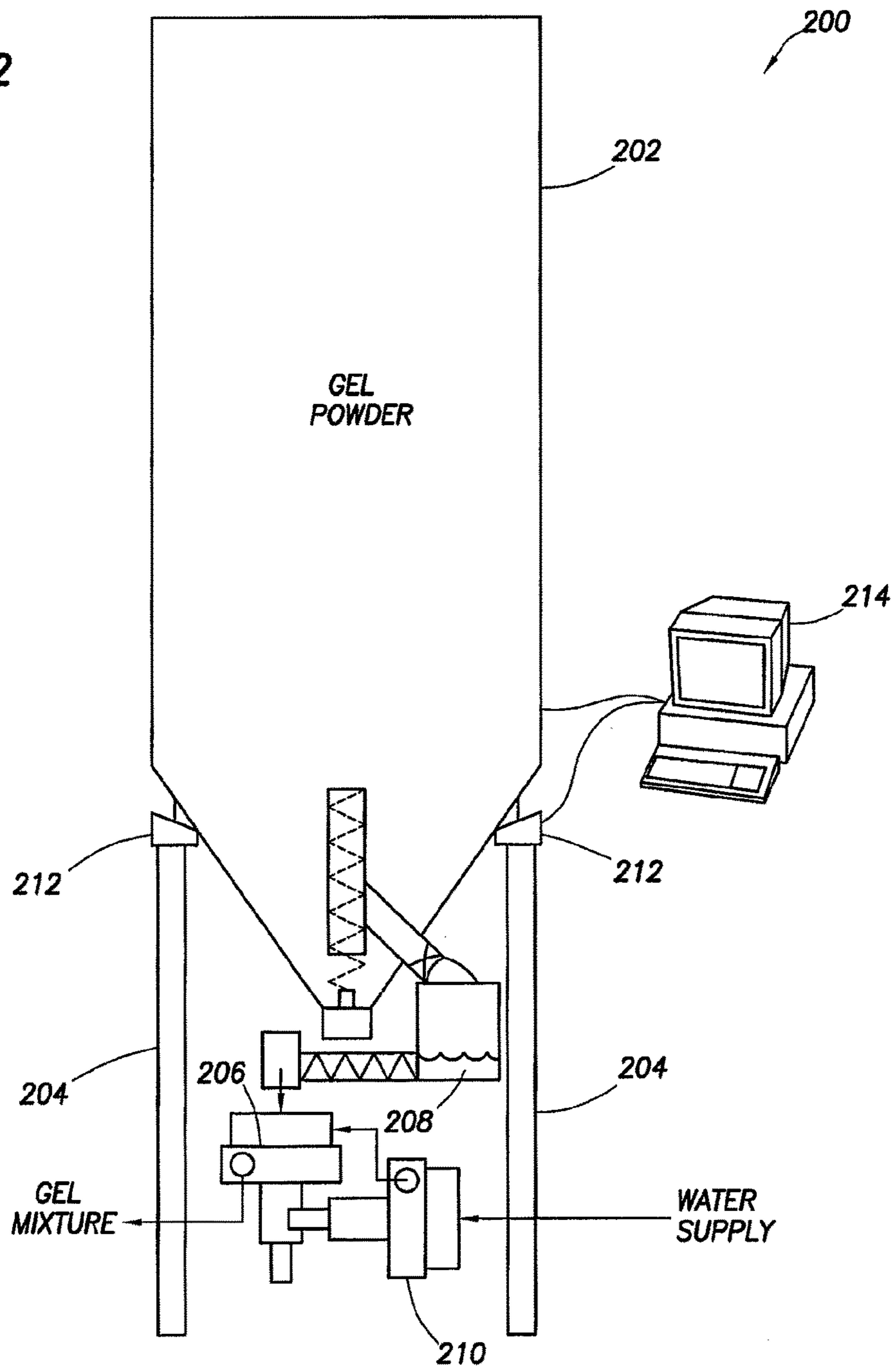
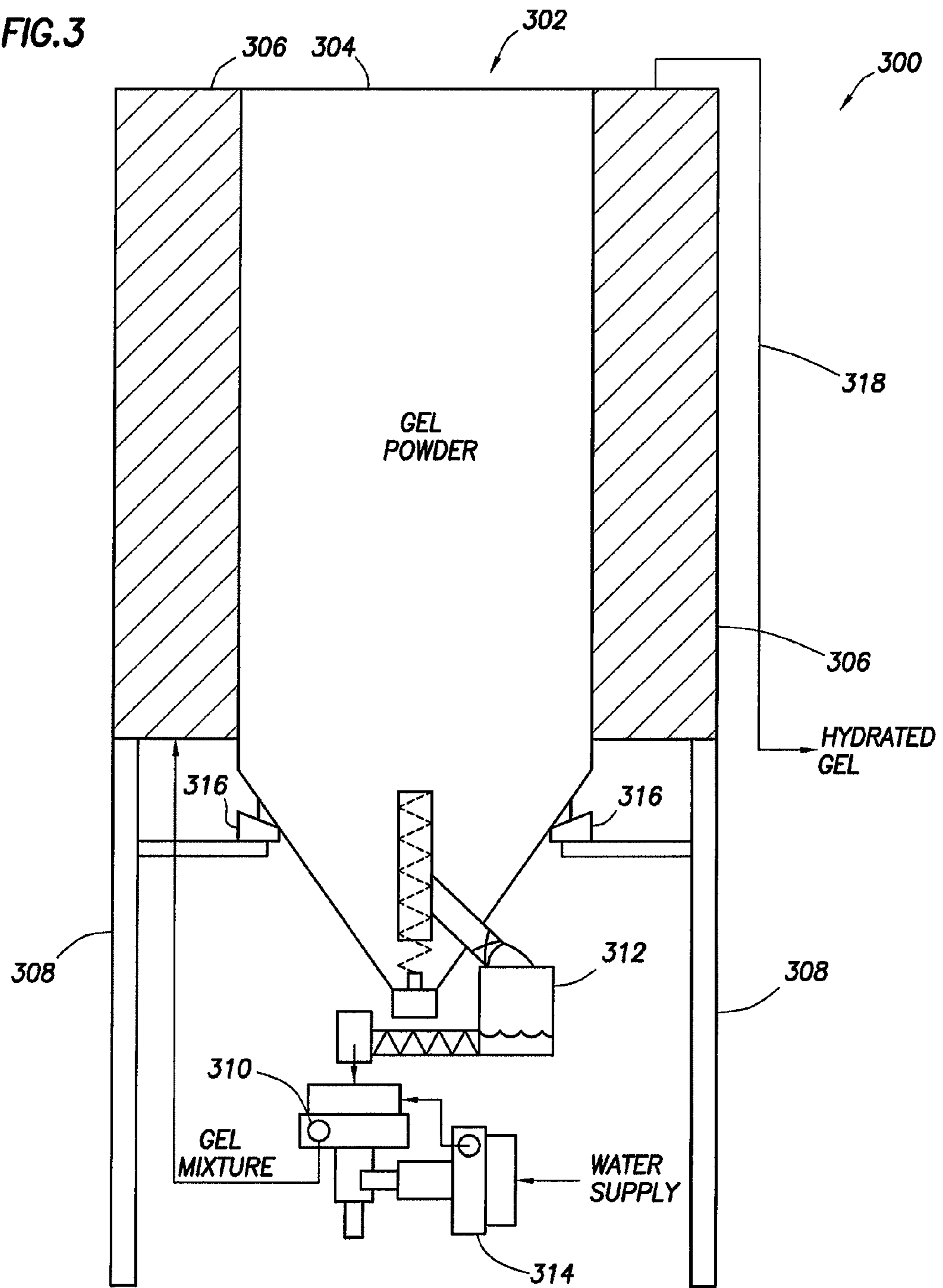
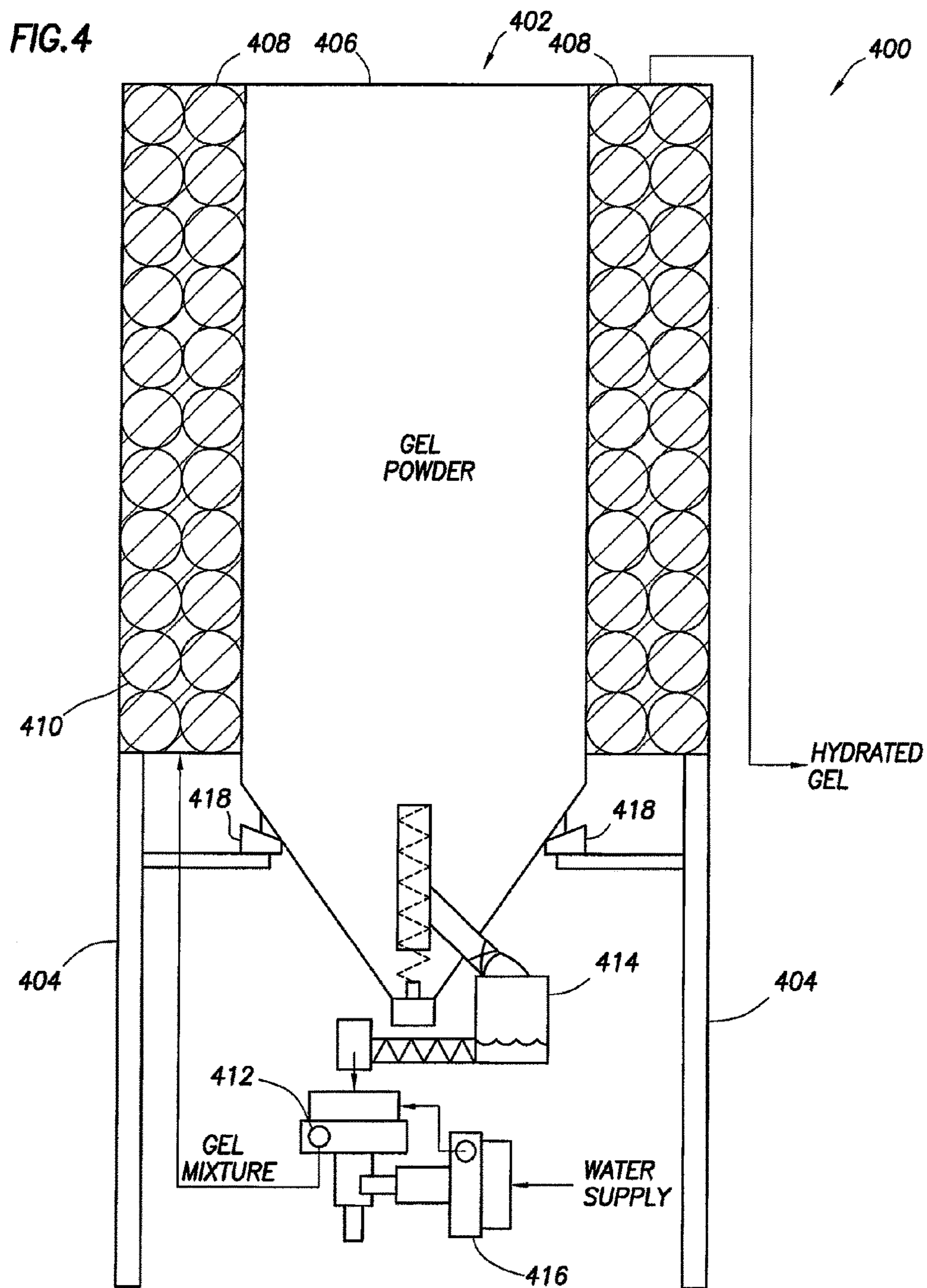
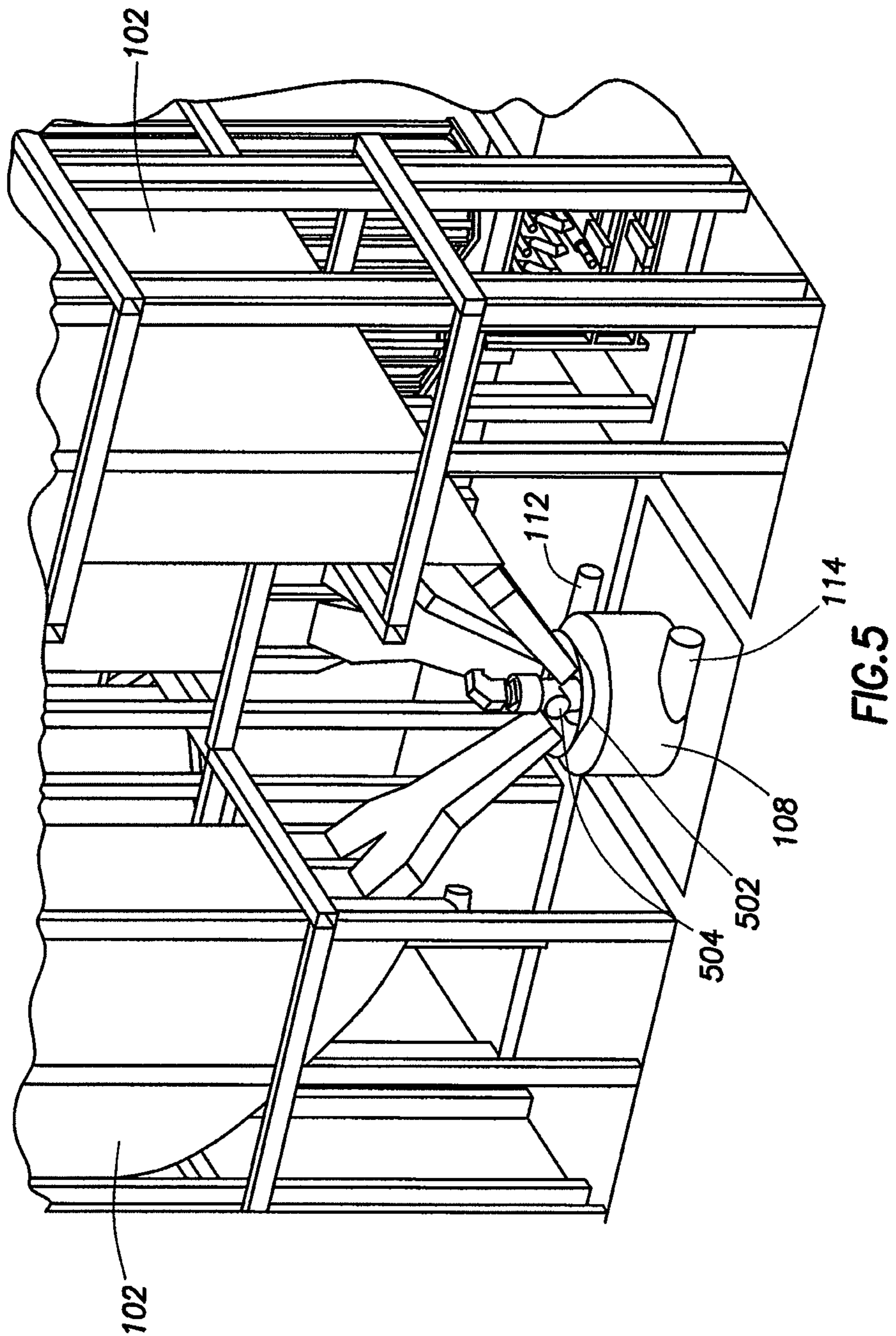

FIG.3







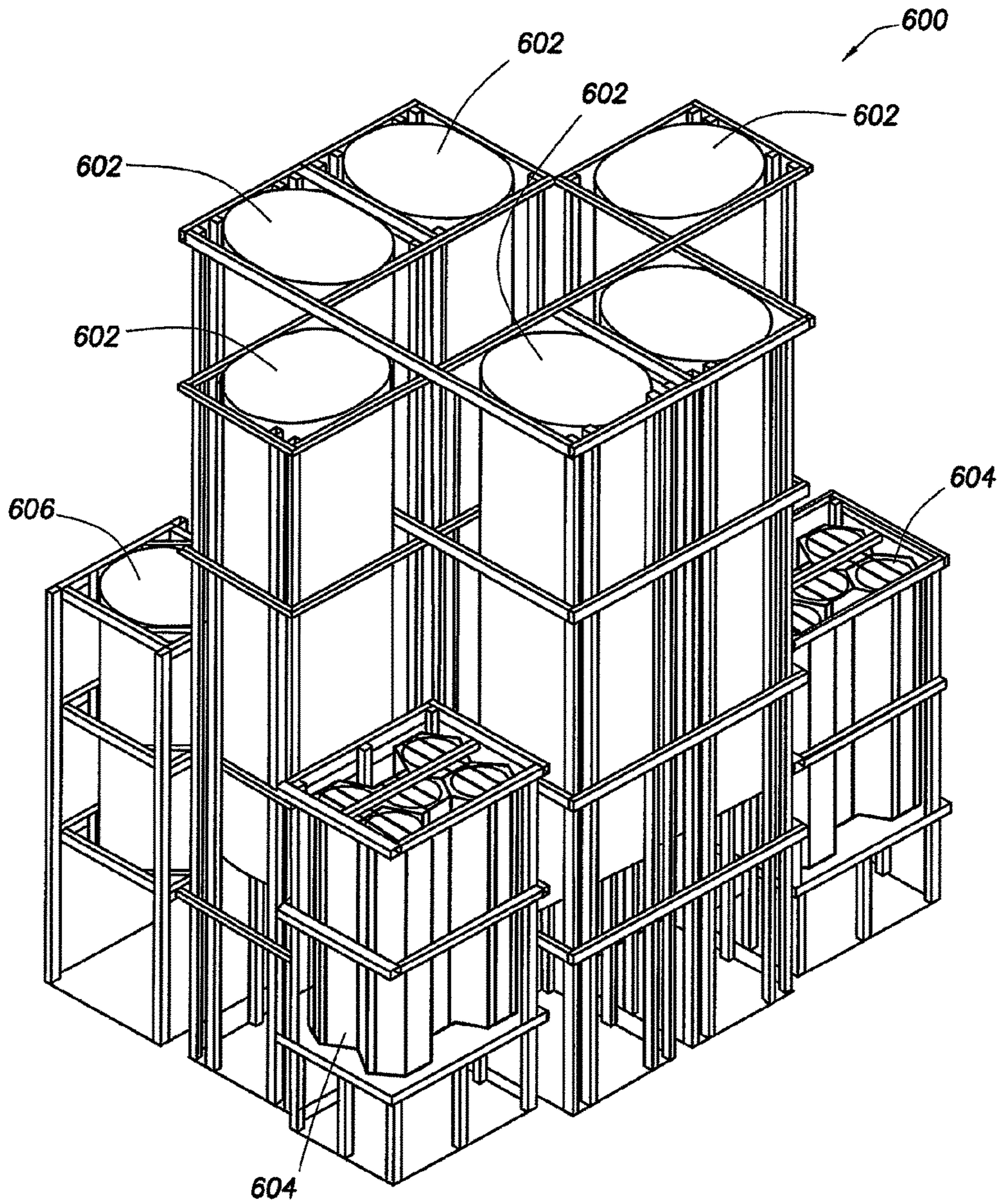

FIG. 6

**ELECTRIC OR NATURAL GAS FIRED
SMALL FOOTPRINT FRACTURING FLUID
BLENDING AND PUMPING EQUIPMENT**

Matter enclosed in heavy brackets [] appears in the original patent but forms no part of this reissue specification; matter printed in italics indicates the additions made by reissue; a claim printed with strikethrough indicates that the claim was canceled, disclaimed, or held invalid by a prior post-patent action or proceeding.

CROSS REFERENCE TO RELATED
APPLICATIONS

This is an application for reissue of U.S. Pat. No. 8,834,012, application Ser. No. 12/774,959, filed on May 6, 2010.

This application is a continuation-in-part of U.S. patent application Ser. No. 12/557,730, filed Sep. 11, 2009, now U.S. Pat. No. 8,444,312 entitled "Improved Methods and Systems for Integral Blending and Storage of Materials," the entire disclosure of which is incorporated herein by reference.

BACKGROUND

The present invention relates generally to oilfield operations, and more particularly, to methods and systems for integral storage and blending of the materials used in oilfield operations.

Oilfield operations are conducted in a variety of different locations and involve a number of equipments, depending on the operations at hand. The requisite materials for the different operations are often hauled to and stored at the well site where the operations are to be performed.

Considering the number of equipments necessary for performing oilfield operations and ground conditions at different oilfield locations, space availability is often a constraint. For instance, in well treatment operations such as fracturing operations, several wells may be serviced from a common jobsite pad. In such operations, the necessary equipment is not moved from well site to well site. Instead, the equipment may be located at a central work pad and the required treating fluids may be pumped to the different well sites from this central location. Accordingly, the bulk of materials required at a centralized work pad may be enormous, further limiting space availability.

Typically, in modern well treatment operations, equipment is mounted on a truck or a trailer and brought to location and set up. The storage units used are filled with the material required to prepare the well treatment fluid and perform the well treatment. In order to prepare the well treatment fluid, the material used is then transferred from the storage units to one or more blenders to prepare the desired well treatment fluid which may then be pumped down hole.

For instance, in conventional fracturing operations a blender and a pre-gel blender are set between the high pressure pumping units and the storage units which contain the dry materials and chemicals used. The dry materials and the chemicals used in the fracturing operations are then transferred, often over a long distance, from the storage units to the mixing and blending equipments. Once the treating process is initiated, the solid materials and chemicals are typically conveyed to the blender by a combination of conveyer belts, screw type conveyers and a series of hoses and pumps.

The equipment used for transferring the dry materials and chemicals from the storage units to the blender occupy valuable space at the job site. Additionally, the transfer of dry materials and chemicals to the blender consumes a significant amount of energy as well as other system resources and contributes to the carbon foot print of the job site. Moreover, in typical "on land" operations the entire equipment spread including the high horsepower pumping units are powered by diesel fired engines and the bulk material metering, conveying and pumping is done with diesel fired hydraulic systems. Emissions from the equipment that is powered by diesel fuel contributes to the overall carbon footprint and adversely affects the environment.

FIGURES

Some specific example embodiments of the disclosure may be understood by referring, in part, to the following description and the accompanying drawings.

FIG. 1 is a top view of an Integrated Material Storage and Blending System in accordance with an exemplary embodiment of the present invention.

FIG. 2 is a cross sectional view of an Integrated Pre-gel Blender in accordance with a first exemplary embodiment of the present invention.

FIG. 3 is a cross sectional view of an Integrated Pre-gel Blender in accordance with a second exemplary embodiment of the present invention.

FIG. 4 is a cross sectional view of an Integrated Pre-gel Blender in accordance with a third exemplary embodiment of the present invention.

FIG. 5 depicts a close up view of the interface between the storage units and a blender in an Integrated Material Storage and Blending System in accordance with an exemplary embodiment of the present invention.

FIG. 6 is an isometric view of an Integrated Material Storage and Blending System in accordance with an exemplary embodiment of the present invention.

While embodiments of this disclosure have been depicted and described and are defined by reference to example embodiments of the disclosure, such references do not imply a limitation on the disclosure, and no such limitation is to be inferred. The subject matter disclosed is capable of considerable modification, alteration, and equivalents in form and function, as will occur to those skilled in the pertinent art and having the benefit of this disclosure. The depicted and described embodiments of this disclosure are examples only, and not exhaustive of the scope of the disclosure.

SUMMARY

The present invention relates generally to oilfield operations, and more particularly, to methods and systems for integral storage and blending of the materials used in oilfield operations.

In one embodiment, the present invention is directed to an integrated material blending and storage system comprising: a storage unit; a blender located under the storage unit; wherein the blender is operable to receive a first input from the storage unit; a liquid additive storage module having a pump to maintain constant pressure at an outlet of the liquid additive storage module; wherein the blender is operable to receive a second input from the liquid additive storage module; and a pre-gel blender; wherein the blender is operable to receive a third input from the pre-gel blender; wherein gravity directs the contents of the storage unit, the liquid additive storage module and the pre-gel blender to the

blender; a first pump; and a second pump; wherein the first pump directs the contents of the blender to the second pump; and wherein the second pump directs the contents of the blender down hole; wherein at least one of the first pump and the second pump is powered by one of natural gas and electricity.

In another exemplary embodiment, the present invention is directed to a modular integrated material blending and storage system comprising: a first module comprising a storage unit; a second module comprising a liquid additive storage unit and a pump for maintaining pressure at an outlet of the liquid additive storage unit; and a third module comprising a pre-gel blender; wherein an output of each of the first module, the second module and the third module is located above a blender; and wherein gravity directs the contents of the first module, the second module and the third module to the blender; a pump; wherein the pump directs the output of the blender to a desired down hole location; and wherein the pump is powered by one of natural gas and electricity.

The features and advantages of the present disclosure will be readily apparent to those skilled in the art upon a reading of the description of exemplary embodiments, which follows.

DESCRIPTION

The present invention relates generally to oilfield operations, and more particularly, to methods and systems for integral storage and blending of the materials used in oilfield operations.

Turning now to FIG. 1, an Integrated Material Storage and Blending System (IMSBS) in accordance with an exemplary embodiment of the present invention is depicted generally with reference numeral 100. The IMSBS 100 includes a number of storage units 102. The storage units 102 may contain sand, proppants or other solid materials used to prepare a desired well treatment fluid.

In one exemplary embodiment, the storage units 102 may be connected to load sensors (not shown) to monitor the reaction forces at the legs of the storage units 102. The load sensor readings may then be used to monitor the change in weight, mass and/or volume of materials in the storage units 102. The change in weight, mass or volume can be used to control the metering of material from the storage units 102 during well treatment operations. As a result, the load sensors may be used to ensure the availability of materials during oilfield operations. In one exemplary embodiment, load cells may be used as load sensors. Electronic load cells are preferred for their accuracy and are well known in the art, but other types of force-measuring devices may be used. As will be apparent to one skilled in the art, however, any type of load-sensing device can be used in place of or in conjunction with a load cell. Examples of suitable load-measuring devices include weight-, mass-, pressure- or force-measuring devices such as hydraulic load cells, scales, load pins, dual shear beam load cells, strain gauges and pressure transducers. Standard load cells are available in various ranges such as 0-5000 pounds, 0-10000 pounds, etc.

In one exemplary embodiment the load sensors may be communicatively coupled to an information handling system 104 which may process the load sensor readings. While FIG. 1 depicts a separate information handling system 104 for each storage unit 102, as would be appreciated by those of ordinary skill in the art, with the benefit of this disclosure, a single information handling system may be used for all or any combination of the storage units 102. Although FIG. 1

depicts a personal computer as the information handling system 104, as would be apparent to those of ordinary skill in the art, with the benefit of this disclosure, the information handling system 104 may include any instrumentality or aggregate of instrumentalities operable to compute, classify, process, transmit, receive, retrieve, originate, switch, store, display, manifest, detect, record, reproduce, handle, or utilize any form of information, intelligence, or data for business, scientific, control, or other purposes. For example, the information handling system 104 may be a network storage device, or any other suitable device and may vary in size, shape, performance, functionality, and price. For instance, in one exemplary embodiment, the information handling system 104 may be used to monitor the amount of materials in the storage units 102 over time and/or alert a user when the contents of a storage unit 102 reaches a threshold level. The user may designate a desired sampling interval at which the information handling system 104 may take a reading of the load sensors.

The information handling system 104 may then compare the load sensor readings to the threshold value to determine if the threshold value is reached. If the threshold value is reached, the information handling system 104 may alert the user. In one embodiment, the information handling system 104 may provide a real-time visual depiction of the amount of materials contained in the storage units 102. Moreover, as would be appreciated by those of ordinary skill in the art, with the benefit of this disclosure, the load sensors may be coupled to the information handling system 104 through a wired or wireless (not shown) connection.

As depicted in FIG. 1, the IMSBS 100 may also include one or more Integrated Pre-gel Blenders (IPB) 106. The IPB 106 may be used for preparing any desirable well treatment fluids such as a fracturing fluid, a sand control fluid or any other fluid requiring hydration time.

FIG. 2 depicts an IPB 200 in accordance with an exemplary embodiment of the present invention. The IPB 200 comprises a pre-gel storage unit 202 resting on legs 204. As would be appreciated by those of ordinary skill in the art, the pre-gel storage unit 202 may be a storage bin, a tank, or any other desirable storage unit. The pre-gel storage unit 202 may contain the gel powder used for preparing the gelled fracturing fluid. As would be appreciated by those of ordinary skill in the art, with the benefit of this disclosure, the gel powder may comprise a dry polymer. Specifically, the dry polymer may be any agent used to enhance fluid properties, including, but not limited to, wg18, wg35, wg36 (available from Halliburton Energy Services of Duncan, Okla.) or any other guar or modified guar gelling agents. The materials from the pre-gel storage unit 202 may be directed to a mixer 206 as a first input through a feeder 208. As would be appreciated by those of ordinary skill in the art, with the benefit of this disclosure, in one embodiment, the mixer 206 may be a growler mixer and the feeder 208 may be a screw feeder which may be used to provide a volumetric metering of the materials directed to the mixer 206. A water pump 210 may be used to supply water to the mixer 206 as a second input. A variety of different pumps may be used as the water pump 210 depending on the user preferences. For instance, the water pump 210 may be a centrifugal pump, a progressive cavity pump, a gear pump or a peristaltic pump. The mixer 206 mixes the gel powder from the pre-gel storage unit 202 with the water from the water pump 210 at the desired concentration and the finished gel is discharged from the mixer 206 and may be directed to a storage unit, such as an external frac tank (not shown), for hydration. The finished gel may then be directed to a blender 108 in the IMSBS 100.

In one exemplary embodiment, the legs **204** of the pre-gel storage unit **202** are attached to load sensors **212** to monitor the reaction forces at the legs **204**. The load sensor **212** readings may then be used to monitor the change in weight, mass and/or volume of materials in the pre-gel storage unit **202**. The change in weight, mass or volume can be used to control the metering of material from the pre-gel storage unit **202** at a given set point. As a result, the load sensors **212** may be used to ensure the availability of materials during oilfield operations. In one exemplary embodiment, load cells may be used as load sensors **212**. Electronic load cells are preferred for their accuracy and are well known in the art, but other types of force-measuring devices may be used. As will be apparent to one skilled in the art, however, any type of load-sensing device can be used in place of or in conjunction with a load cell. Examples of suitable load-measuring devices include weight-, mass-, pressure- or force-measuring devices such as hydraulic load cells, scales, load pins, dual shear beam load cells, strain gauges and pressure transducers. Standard load cells are available in various ranges such as 0-5000 pounds, 0-10000 pounds, etc.

In one exemplary embodiment the load sensors **212** may be communicatively coupled to an information handling system **214** which may process the load sensor readings. Although FIG. 2 depicts a personal computer as the information handling system **214**, as would be apparent to those of ordinary skill in the art, with the benefit of this disclosure, the information handling system **214** may include any instrumentality or aggregate of instrumentalities operable to compute, classify, process, transmit, receive, retrieve, originate, switch, store, display, manifest, detect, record, reproduce, handle, or utilize any form of information, intelligence, or data for business, scientific, control, or other purposes. For example, the information handling system **214** may be a network storage device, or any other suitable device and may vary in size, shape, performance, functionality, and price. For instance, in one exemplary embodiment, the information handling system **214** may be used to monitor the amount of materials in the pre-gel storage unit **202** over time and/or alert a user when the contents of the pre-gel storage unit **202** reaches a threshold level. The user may designate a desired sampling interval at which the information handling system **214** may take a reading of the load sensors **212**. The information handling system **214** may then compare the load sensor readings to the threshold value to determine if the threshold value is reached. If the threshold value is reached, the information handling system **214** may alert the user. In one embodiment, the information handling system **214** may provide a real-time visual depiction of the amount of materials contained in the pre-gel storage unit **202**.

Moreover, as would be appreciated by those of ordinary skill in the art, with the benefit of this disclosure, the load sensors **212** may be coupled to the information handling system **214** through a wired or wireless (not shown) connection. As would be appreciated by those of ordinary skill in the art, with the benefit of this disclosure, in one exemplary embodiment, the dry polymer material may be replaced with a Liquid Gel Concentrate ("LGC") material that consists of the dry polymer mixed in a carrier fluid. In this exemplary embodiment, the feeder and mixer mechanisms would be replaced with a metering pump of suitable construction to inject the LGC into the water stream, thus initiating the hydration process.

FIG. 3 depicts an IPB in accordance with a second exemplary embodiment of the present invention, denoted generally by reference numeral **300**. The IPB **300** comprises

a pre-gel storage unit **302** resting on legs **308**. The pre-gel storage unit **302** in this embodiment may include a central core **304** for storage and handling of materials. In one embodiment, the central core **304** may be used to store a dry gel powder for making gelled fracturing fluids. The pre-gel storage unit **302** may further comprise an annular space **306** for hydration volume. As would be appreciated by those of ordinary skill in the art, with the benefit of this disclosure, the gel powder may comprise a dry polymer. Specifically, the dry polymer may comprise a number of different materials, including, but not limited to, wg18, wg35, wg36 (available from Halliburton Energy Services of Duncan, Okla.) or any other guar or modified guar gelling agents.

The materials from the central core **304** of the pre-gel storage unit **302** may be directed to a mixer **310** as a first input through a feeder **312**. As would be appreciated by those of ordinary skill in the art, with the benefit of this disclosure, in one embodiment, the mixer **310** may be a growler mixer and the feeder **312** may be a screw feeder which may be used to provide a volumetric metering of the materials directed to the mixer **310**. A water pump **314** may be used to supply water to the mixer **310** as a second input. A variety of different pumps may be used as the water pump **314** depending on the user preferences. For instance, the water pump **314** may be a centrifugal pump, a progressive cavity pump, a gear pump or a peristaltic pump. The mixer **310** mixes the gel powder from the pre-gel storage unit **302** with the water from the water pump **314** at the desired concentration and the finished gel is discharged from the mixer **310**. As discussed above with reference to the storage units **102**, the pre-gel storage unit **302** may rest on load sensors **316** which may be used for monitoring the amount of materials in the pre-gel storage unit **302**. The change in weight, mass or volume can be used to control the metering of material from the pre-gel storage unit **302** at a given set point.

In this embodiment, once the gel having the desired concentration is discharged from the mixer **310**, it is directed to the annular space **306**. The gel mixture is maintained in the annular space **306** for hydration. Once sufficient time has passed and the gel is hydrated, it is discharged from the annular space **306** through the discharge line **318**.

FIG. 4 depicts a cross sectional view of a storage unit in an IPB **400** in accordance with a third exemplary embodiment of the present invention. The IPB **400** comprises a pre-gel storage unit **402** resting on legs **404**. The pre-gel storage unit **402** in this embodiment may include a central core **406** for storage and handling of materials. In one embodiment, the central core **406** may be used to store a dry gel powder for making gelled fracturing fluids. As would be appreciated by those of ordinary skill in the art, with the benefit of this disclosure, the gel powder may comprise a dry polymer. Specifically, the dry polymer may be any agent used to enhance fluid properties, including, but not limited to, wg18, wg35, wg36 (available from Halliburton Energy Services of Duncan, Okla.) or any other guar or modified guar gelling agents. The pre-gel storage unit **402** may further comprise an annular space **408** which may be used as a hydration volume. In this embodiment, the annular space **408** contains a tubular hydration loop **410**.

The materials from the central core **406** of the pre-gel storage unit **402** may be directed to a mixer **412** as a first input through a feeder **414**. As would be appreciated by those of ordinary skill in the art, with the benefit of this disclosure, in one embodiment, the mixer **412** may be a growler mixer and the feeder **414** may be a screw feeder which may be used to provide a volumetric metering of the

materials directed to the mixer **412**. A water pump **416** may be used to supply water to the mixer **412** as a second input. A variety of different pumps may be used as the water pump **416** depending on the user preferences. For instance, the water pump **416** may be a centrifugal pump, a progressive cavity pump, a gear pump or a peristaltic pump. The mixer **412** mixes the gel powder from the pre-gel storage unit **402** with the water from the water pump **416** at the desired concentration and the finished gel is discharged from the mixer **412**. As discussed above with reference to FIG. 1, the pre-gel storage unit **402** may rest on load sensors **418** which may be used for monitoring the amount of materials in the pre-gel storage unit **402**. The change in weight, mass or volume can be used to control the metering of material from the pre-gel storage unit **402** at a given set point.

In this embodiment, once the gel having the desired concentration is discharged from the mixer **412**, it is directed to the annular space **408** where it enters the tubular hydration loop **410**. As would be appreciated by those of ordinary skill in the art, with the benefit of this disclosure, the portions of the gel mixture are discharged from the mixer **412** at different points in time, and accordingly, will be hydrated at different times. Specifically, a portion of the gel mixture discharged from the mixer **412** into the annular space **408** at a first point in time, t_1 , will be sufficiently hydrated before a portion of the gel mixture which is discharged into the annular space **408** at a second point in time, t_2 . Accordingly, it is desirable to ensure that the gel mixture is transferred through the annular space **408** in a First-In-First-Out (FIFO) mode. To that end, in the third exemplary embodiment, a tubular hydration loop **410** is inserted in the annular space **408** to direct the flow of the gel as it is being hydrated.

As would be appreciated by those of ordinary skill in the art, with the benefit of this disclosure, in order to achieve optimal performance, the tubular hydration loop **410** may need to be cleaned during a job or between jobs. In one embodiment, the tubular hydration loop **410** may be cleaned by passing a fluid such as water through it. In another exemplary embodiment, a pigging device may be used to clean the tubular hydration loop **410**.

Returning to FIG. 1, the IMSBS **100** may include one or more blenders **108** located at the bottom of the storage units **102**. In one embodiment, multiple storage units **102** may be positioned above a blender **108** and be operable to deliver solid materials to the blender **108**. FIG. 5 depicts a close up view of the interface between the storage units **102** and the blender **108**. As depicted in FIG. 5, gravity directs the solid materials from the storage units **102** to the blender **108** through the hopper **502**, obviating the need for a conveyor system.

Returning to FIG. 1, the IMSBS **100** may also include one or more liquid additive storage modules **110**. The liquid additive storage modules **110** may contain a fluid used in preparing the desired well treatment fluid. As would be appreciated by those of ordinary skill in the art, with the benefit of this disclosure, depending on the well treatment fluid being prepared, a number of different fluids may be stored in the liquid additive storage modules **110**. Such fluids may include, but are not limited to, surfactants, acids, cross-linkers, breakers, or any other desirable chemical additives. As discussed in detail with respect to storage units **102**, load sensors (not shown) may be used to monitor the amount of fluid in the liquid additive storage modules **110** in real time and meter the amount of fluids delivered to the blender **108**. As would be appreciated by those of ordinary skill in the art, with the benefit of this disclosure, a pump may be used to circulate the contents and maintain constant

pressure at the head of the liquid additive storage modules **110**. Because the pressure of the fluid at the outlet of the liquid additive storage modules **110** is kept constant and the blender **108** is located beneath the liquid additive storage modules **110**, gravity assists in directing the fluid from the liquid additive storage modules **110** to the blender **108**, thereby obviating the need for a pump or other conveyor systems to transfer the fluid.

As depicted in more detail in FIG. 5, the blender **108** includes a fluid inlet **112** and an optional water inlet **504**. Once the desired materials are mixed in the blender **108**, the materials exit the blender **108** through the outlet **114**.

In one embodiment, when preparing a well treatment fluid, a base gel is prepared in the IPB **106**. In one embodiment, the gel prepared in the IPB may be directed to an annular space **406** for hydration. In another exemplary embodiment, the annular space may further include a hydration loop **410**. In one exemplary embodiment, the resulting gel from the IPB **106** may be pumped to the centrally located blender **108**. Each of the base gel, the fluid modifying agents and the solid components used in preparing a desired well treatment fluid may be metered out from the IPB **106**, the liquid additive storage module **110** and the storage unit **102**, respectively. The blender **108** mixes the base gel with other fluid modifying agents from the liquid additive storage modules **110** and the solid component(s) from the storage units **102**. As would be appreciated by those of ordinary skill in the art, with the benefit of this disclosure, when preparing a fracturing fluid the solid component may be a dry proppant. In one exemplary embodiment, the dry proppant may be gravity fed into the blending tub through metering gates. Once the blender **108** mixes the base gel, the fluid modifying agent and the solid component(s), the resulting well treatment fluid may be directed to a down hole pump (not shown) through the outlet **114**. A variety of different pumps may be used to pump the output of the IMSBS down hole. For instance, the pump used may be a centrifugal pump, a progressive cavity pump, a gear pump or a peristaltic pump. In one exemplary embodiment, chemicals from the liquid additive storage modules **110** may be injected in the manifolds leading to and exiting the blender **108** in order to bring them closer to the centrifugal pumps and away from other chemicals when there are compatibility or reaction issues.

As would be appreciated by those of ordinary skill in the art, with the benefit of this disclosure, the mixing and blending process may be accomplished at the required rate dictated by the job parameters. As a result, pumps that transfer the final slurry to the down hole pumps typically have a high horsepower requirement. In one exemplary embodiment, the transfer pump may be powered by a natural gas fired engine or a natural gas fired generator set. In another exemplary embodiment, the transfer pump may be powered by electricity from a power grid. Once the fluid system is mixed and blended with proppant and other fluid modifiers it is boosted to the high horsepower down hole pumps. The down hole pumps pump the slurry through the high pressure ground manifold to the well head and down hole. In one embodiment, the down hole pumps may be powered by a natural gas fired engine, a natural gas fired generator set or electricity from a power grid. The down hole pumps typically account for over two third of the horsepower on location, thereby reducing the carbon footprint of the overall operations.

In one exemplary embodiment, the natural gas used to power the transfer pumps, the down hole pumps or the other system components may be obtained from the field on which the subterranean operations are being performed. In one

embodiment, the natural gas may be converted to liquefied natural gas and used to power pumps and other equipment that would typically be powered by diesel fuel. In another embodiment, the natural gas may be used to provide power through generator sets. The natural gas from the field may undergo conditioning before being used to provide power to the pumps and other equipment. The conditioning process may include cleaning the natural gas, compressing the natural gas in compressor stations and if necessary, removing any water contained therein.

As would be appreciated by those of ordinary skill in the art, with the benefit of this disclosure, the IMSBS may include a different number of storage units **102**, IPBs **106** and/or liquid additive storage modules **110**, depending on the system requirements. For instance, in another exemplary embodiment (not shown), the IMSBS may include three storage units, one IPB and one liquid additive storage module.

FIG. 6 depicts an isometric view of IMSBS in accordance with an exemplary embodiment of the present invention, denoted generally with reference numeral **600**. As depicted in FIG. 6, each of the storage units **602**, each of the liquid additive storage modules **604** and each of the IPBs **606** may be arranged as an individual module. In one embodiment, one or more of the storage units **602**, the liquid additive storage modules **604** and the IPBs **606** may include a latch system which is couplable to a truck or trailer which may be used for transporting the module. In one embodiment, the storage units **602** may be a self-erecting storage unit as disclosed in U.S. patent application Ser. No. 12/235,270, assigned to Halliburton Energy Services, Inc., which is incorporated by reference herein in its entirety. Accordingly, the storage units **602** may be specially adapted to connect to a vehicle which may be used to lower, raise and transport the storage unit **602**. Once at a jobsite, the storage unit **602** may be erected and filled with a predetermined amount of a desired material. A similar design may be used in conjunction with each of the modules of the IMSBS **600** disclosed herein in order to transport the modules to and from a job site. Once the desired number of storage units **602**, the liquid additive storage modules **604** and the IPBs **606** are delivered to a job site, they are erected in their vertical position. Dry materials such as proppants or gel powder may then be filled pneumatically to the desired level and liquid chemicals may be pumped into the various storage tanks. Load sensors (not shown) may be used to monitor the amount of materials added to the storage units **602**, the liquid additive storage modules **604** and the IPBs **606** in real time.

As would be appreciated by those of ordinary skill in the art, with the benefit of this disclosure, an IMSBS **600** in accordance with an exemplary embodiment of the present invention which permits accurate, real-time monitoring of the contents of the storage units **602**, the liquid additive storage modules **604** and/or the IPBs **606** provides several advantages. For instance, an operator may use the amount of materials remaining in the storage units **602**, the liquid additive storage modules **604** and/or the IPBs **606** as a quality control mechanism to ensure that material consumption is in line with the job requirements. Additionally, the accurate, real-time monitoring of material consumption expedites the operator's ability to determine the expenses associated with a job.

As would be appreciated by those of ordinary skill in the art, with the benefit of this disclosure, the different equipment used in an IMSBS in accordance with the present invention may be powered by any suitable power source. For instance, the equipment may be powered by a combustion

engine, electric power supply which may be provided by an on-site generator or by a hydraulic power supply.

Therefore, the present invention is well-adapted to carry out the objects and attain the ends and advantages mentioned as well as those which are inherent therein. While the invention has been depicted and described by reference to exemplary embodiments of the invention, such a reference does not imply a limitation on the invention, and no such limitation is to be inferred. The invention is capable of considerable modification, alteration, and equivalents in form and function, as will occur to those ordinarily skilled in the pertinent arts and having the benefit of this disclosure. The depicted and described embodiments of the invention are exemplary only, and are not exhaustive of the scope of the invention. Consequently, the invention is intended to be limited only by the spirit and scope of the appended claims, giving full cognizance to equivalents in all respects. The terms in the claims have their plain, ordinary meaning unless otherwise explicitly and clearly defined by the patentee.

What is claimed is:

1. An integrated material blending and storage system comprising:

a storage unit;

a blender located under the storage unit;

wherein the blender is operable to receive a first input from the storage unit through a hopper;

a liquid additive storage module having a first pump to maintain constant pressure at an outlet of the liquid additive storage module;

wherein the blender is operable to receive a second input from the liquid additive storage module; and

a pre-gel blender, wherein the pre-gel blender comprises at least a pre-gel storage unit resting on a leg, further wherein the pre-gel storage unit comprises a central core and an annular space, wherein the annular space hydrates the contents of the pre-gel blender;

wherein the blender is operable to receive a third input from the pre-gel blender;

wherein gravity directs the contents of the storage unit, the liquid additive storage module and the pre-gel blender to the blender;

a second pump; and

a third pump;

wherein the second pump directs the contents of the blender to the third pump; and

wherein the third pump directs the contents of the blender down hole;

wherein at least one of the second pump and the third pump is powered by one of natural gas and electricity.

2. The system of claim 1, wherein the storage unit comprises a load sensor.

3. The system of claim 1, wherein the pre-gel blender comprises:

a feeder coupling the pre-gel storage unit to a first input of a mixer;

a fourth pump coupled to a second input of the mixer; wherein the pre-gel storage unit contains a solid component of a well treatment fluid;

wherein the feeder supplies the solid component of the well treatment fluid to the mixer;

wherein the fourth pump supplies a fluid component of the well treatment fluid to the mixer; and

wherein the mixer outputs a well treatment fluid.

4. The system of claim 3, wherein the well treatment fluid is a gelled fracturing fluid.

5. The system of claim 4, wherein the solid component is a gel powder.

11

6. The system of claim 4, wherein the fluid component is water.

7. The system of claim 3, wherein the central core contains the solid component of the well treatment fluid.

8. The system of claim 3, wherein the well treatment fluid is directed to the annular space.

9. The system of claim 3, wherein the annular space comprises a tubular hydration loop.

10. The system of claim 9, wherein the well treatment fluid is directed from the mixer to the tubular hydration loop.

11. The system of claim 3, wherein the well treatment fluid is selected from the group consisting of a fracturing fluid and a sand control fluid.

12. The system of claim 3, further comprising a power source to power at least one of the feeder, the mixer and the pump.

13. The system of claim 12, wherein the power source is selected from the group consisting of a combustion engine, an electric power supply and a hydraulic power supply.

14. The system of claim 13, wherein one of the combustion engine, the electric power supply and the hydraulic power supply is powered by natural gas.

15. The system of claim 1, further comprising a load sensor coupled to one of the storage unit, the liquid additive storage module or the pre-gel blender.

16. The system of claim 15, further comprising an information handling system communicatively coupled to the load sensor.

17. The system of claim 15, wherein the load sensor is a load cell.

18. The system of claim 15, wherein a reading of the load sensor is used for quality control.

19. The system of claim 1, wherein the electricity is derived from one of a power grid and a natural gas generator set.

20. A modular integrated material blending and storage system comprising:

a first module comprising a storage unit;

a second module comprising a liquid additive storage unit and a first pump for maintaining pressure at an outlet of the liquid additive storage unit; and

a third module comprising a pre-gel blender, wherein the pre-gel blender comprises at least a pre-gel storage unit resting on a leg, further wherein the pre-gel storage unit comprises a central core and an annular space, wherein the annular space hydrates the contents of the pre-gel blender;

wherein an output of each of the first module, the second module and the third module is located above a blender; and

wherein gravity directs the contents of the first module through a hopper, the second module and the third module to the blender;

a second pump;

wherein the second pump directs the output of the blender to a desired down hole location; and

wherein the second pump is powered by one of natural gas and electricity.

21. The system of claim 20, wherein each of the first module, the second module and the third module is a self erecting module.

22. The system of claim 20, wherein the third module comprises:

a feeder coupling the pre-gel storage unit to a first input of a mixer;

12

a third pump coupled to a second input of the mixer; wherein the pre-gel storage unit contains a solid component of a well treatment fluid;

wherein the feeder supplies the solid component of the well treatment fluid to the mixer;

wherein the third pump supplies a fluid component of the well treatment fluid to the mixer; and

wherein the mixer outputs a well treatment fluid.

23. The system of claim 22, wherein the well treatment fluid is directed to the blender.

24. The system of claim 20, wherein the blender mixes the output of the first module, the second module and the third module.

25. The system of claim 20, further comprising a fourth pump for pumping an output of the blender down hole.

26. The system of claim 25, wherein the fourth pump is selected from the group consisting of a centrifugal pump, a progressive cavity pump, a gear pump and a peristaltic pump.

27. *A system for preparing fluid for use at a well having a wellbore, the system comprising:*

at least one storage unit adapted to connect to a vehicle for transportation;

at least one pre-gel blender having a pre-gel storage unit, wherein the pre-gel storage unit comprises a central core and an annular space;

at least one blender coupled to receive a component of a first fluid from the at least one storage unit through a hopper, the at least one blender having inputs from at least the at least one storage unit, and the at least one pre-gel blender;

at least one pump for applying pressure to the first fluid or a second fluid, and the at least one pump coupled to provide an input to the at least one blender; and

an electric power supply, including an electrical generator located on-site, providing electrical power to at least one of the at least one blender and the at least one pump.

28. *The system of claim 27 wherein the pre-gel storage unit contains a gel powder.*

29. *The system of claim 27 wherein the pre-gel storage unit rests on at least one leg.*

30. *The system of claim 27 wherein the pre-gel storage unit comprises a space in which contents of the pre-gel storage unit are allowed to hydrate.*

31. *The system of claim 27 wherein contents of the pre-gel storage unit are allowed to hydrate in the annular space.*

32. *The system of claim 27 wherein the central core contains a gel powder.*

33. *The system of claim 32 wherein the gel powder from the pre-gel storage unit is allowed to hydrate in the annular space.*

34. *The system of claim 27 further comprising a liquid additive storage module, wherein the at least one blender further comprises an input from the liquid additive storage module.*

35. *The system of claim 34 wherein the pre-gel storage unit contains a gel powder.*

36. *The system of claim 34 wherein the pre-gel storage unit rests on at least one leg.*

37. *The system of claim 34 wherein the pre-gel storage unit comprises a space in which contents of the pre-gel storage unit are allowed to hydrate.*

38. *The system of claim 34 wherein contents of the pre-gel storage unit are allowed to hydrate in the annular space.*

39. *The system of claim 34 wherein the central core contains a gel powder.*

40. The system of claim 39 wherein the gel powder from the pre-gel storage unit is allowed to hydrate in the annular space.

41. The system of claim 39 wherein the pre-gel storage unit comprises a tubular hydration loop in which contents of the pre-gel storage unit are allowed to hydrate.

42. The system of claim 41 wherein the tubular hydration loop is located in an annular space of the pre-gel storage unit.

43. The system of claim 27 wherein a combustion engine provides power to the system.

44. The system of claim 27 wherein a hydraulic power supply provides power to the system.

45. A system comprising:

at least one storage unit;

at least one pre-gel blender;

at least one pre-gel storage unit coupled to the at least one pre-gel blender, wherein the at least one pre-gel storage unit comprises a central core and an annular space;

at least one blender coupled to receive a component of a fluid from the at least one storage unit through a hopper, the at least one blender having inputs from at least the at least one storage unit and the at least one pre-gel blender;

at least one pump in fluid communication with a wellbore in a subterranean field; and

a power supply, including a natural gas device, providing power to at least one of the at least one blender and the at least one pump.

46. The system of claim 45 wherein the at least one pre-gel storage unit contains a gel powder.

47. The system of claim 45 wherein the at least one pre-gel storage unit rests on at least one leg.

48. The system of claim 45 wherein the at least one pre-gel storage unit comprises a space in which the contents of the at least one pre-gel storage unit are allowed to hydrate.

49. The system of claim 45 wherein the contents of the at least one pre-gel storage unit are allowed to hydrate in the annular space.

50. The system of claim 45 wherein the central core contains a gel powder.

51. The system of claim 50 wherein the contents of the at least one pre-gel storage unit are allowed to hydrate in the annular space.

52. The system of claim 45 further comprising a liquid additive storage module, wherein the at least one blender further comprises an input from the liquid additive storage module.

53. The system of claim 52 wherein the at least one pre-gel storage unit contains a gel powder.

54. The system of claim 52 wherein the at least one pre-gel storage unit rests on at least one leg.

55. The system of claim 52 wherein the at least one pre-gel storage unit comprises a space in which the contents of the at least one pre-gel storage unit are allowed to hydrate.

56. The system of claim 52 wherein the contents of the at least one pre-gel storage unit are allowed to hydrate in the annular space.

57. The system of claim 52 wherein the central core contains a gel powder.

58. The system of claim 57 wherein the contents of the at least one pre-gel storage unit are allowed to hydrate in the annular space.

59. The system of claim 52 wherein the at least one pre-gel storage unit comprises a tubular hydration loop in which the contents of the at least one pre-gel storage unit are allowed to hydrate.

60. The system of claim 59 wherein the tubular hydration loop is located in an annular space of the at least one pre-gel storage unit.

61. The system of claim 45 wherein the natural gas generator is coupled to receive the at least some natural gas originating in the underground formation after it has been converted to liquefied natural gas.

62. The system of claim 45 wherein the natural gas generator is coupled to receive the at least some natural gas originating in the underground formation after it has been conditioned.

63. The system of claim 62 wherein the natural gas is conditioned by cleaning the natural gas.

64. The system of claim 62 wherein the natural gas is conditioned by compressing the natural gas in compressor stations.

65. The system of claim 62 wherein the natural gas is conditioned by removing water from the natural gas.

66. The system of claim 45 wherein the natural gas device is a natural gas fired generator.

67. The system of claim 45 wherein the natural gas device is a natural gas fired engine.

68. The system of claim 45 wherein the natural gas device is coupled to receive at least some natural gas originating from the subterranean field.

69. A system for preparing fluid for use at a well having a wellbore, the system comprising:

at least one storage unit adapted to connect to a vehicle for transportation;

at least one pre-gel blender having a pre-gel storage unit, wherein the pre-gel storage unit comprises a tubular hydration loop in which contents of the pre-gel storage unit are allowed to hydrate;

at least one blender coupled to receive a component of a first fluid from the at least one storage unit through a hopper, the blender having inputs from at least the at least one storage unit, and the at least one pre-gel blender;

at least one pump for applying pressure to the first fluid or a second fluid, and the at least one pump coupled to provide an input to the at least one blender; and

an electric power supply, including an electrical generator located on-site, providing electrical power to at least one of the at least one blender and the at least one pump.

70. A system of claim 69 wherein the tubular hydration loop is located in an annular space of the pre-gel storage unit.

71. A system of claim 69 wherein the at least one storage unit comprises a load sensor.

72. A system of claim 69 wherein the pre-gel storage unit contains a gel powder.

73. A system of claim 69 wherein the pre-gel storage unit rests on at least one leg.

74. A system of claim 69 wherein a combustion engine provides power to the system.

75. A system of claim 69 wherein a hydraulic power supply provides power to the system.

76. A system comprising:

at least one storage unit;

at least one pre-gel blender;

at least one pre-gel storage unit coupled to the at least one pre-gel blender, wherein the at least one pre-gel stor-

15

age unit comprises a tubular hydration loop in which the contents of the at least one pre-gel storage unit are allowed to hydrate;

at least one blender coupled to receive the component of a fluid from the at least one storage unit through a hopper, the blender having inputs from at least the at least one storage unit and the at least one pre-gel blender;

at least one pump in fluid communication with a wellbore in a subterranean field; and

a power supply, including a natural gas device, providing power to at least one of the at least one blender and the at least one pump.

77. The system of claim 76 wherein the tubular hydration loop is located in an annular space of the at least one pre-gel storage unit.

78. A system of claim 76 wherein the at least one storage unit comprises a load sensor.

79. A system of claim 76 wherein the at least one pre-gel storage unit contains a gel powder.

80. A system of claim 76 wherein the at least one pre-gel storage unit rests on at least one leg.

81. A system of claim 76 wherein a combustion engine provides power to the system.

82. A system of claim 76 wherein a hydraulic power supply provides power to the system.

83. A system for preparing fluid for use at a well having a wellbore, the system comprising:

at least one storage unit adapted to connect to a vehicle for transportation;

at least one pre-gel blender having a pre-gel storage unit coupled to the at least one pre-gel blender, wherein the pre-gel storage unit comprises a space in which contents of the pre-gel storage unit are allowed to hydrate;

at least one blender coupled to receive a component of a first fluid from the at least one storage unit through a hopper, the at least one blender having inputs from at least the at least one storage unit, and the pre-gel storage unit;

at least one pump for applying pressure to the first fluid or a second fluid, and the at least one pump coupled to provide an input to the at least one blender; and

16

an electric power supply, including an electrical generator located on-site, providing electrical power to the at least one of the at least one blender and the at least one pump.

84. A system of claim 83 wherein the at least one storage unit comprises a load sensor.

85. A system of claim 83 wherein the pre-gel storage unit contains a gel powder.

86. A system of claim 83 wherein the pre-gel storage unit rests on at least one leg.

87. A system of claim 83 wherein a combustion engine provides power to the system.

88. A system of claim 83 wherein a hydraulic power supply provides power to the system.

89. A system comprising:

at least one storage unit;

at least one pre-gel blender;

at least one pre-gel storage unit coupled to the at least one pre-gel blender and comprising a space in which the contents of the at least one pre-gel storage unit are allowed to hydrate;

at least one blender coupled to receive the component of a fluid from the at least one storage unit through a hopper, the at least one blender having inputs from at least the at least one storage unit and the at least one pre-gel storage unit;

at least one pump in fluid communication with a wellbore in a subterranean field; and

a power supply, including a natural gas device, providing power to at least one of the at least one blender and the at least one pump.

90. A system of claim 89 wherein the at least one storage unit comprises a load sensor.

91. A system of claim 89 wherein the at least one pre-gel storage unit contains a gel powder.

92. A system of claim 89 wherein the at least one pre-gel storage unit rests on at least one leg.

93. A system of claim 89 wherein a combustion engine provides power to the system.

94. A system of claim 89 wherein a hydraulic power supply provides power to the system.

* * * * *

UNITED STATES PATENT AND TRADEMARK OFFICE
CERTIFICATE OF CORRECTION

PATENT NO. : RE46,725 E
APPLICATION NO. : 15/079027
DATED : February 20, 2018
INVENTOR(S) : Case et al.

Page 1 of 1

It is certified that error appears in the above-identified patent and that said Letters Patent is hereby corrected as shown below:

Column 1, Line 24, above the heading, "BACKGROUND" insert:

-- Notice: More than one reissue application has been filed for the reissue of U.S. Patent No. 8,834,012. The reissue applications are U.S. Patent Application Ser. No. 15/079,027 (the present application), now U.S. Patent No. RE46,725, which is a reissue application of U.S. Patent No. 8,834,012, U.S. Patent Application Ser. No. 15/853,076, which is a divisional reissue application of U.S. Patent Application Ser. No. 15/079,027, now U.S. Patent No. RE46,725, copending U.S. Patent Application Ser. No. 16/537,070, which is a continuation reissue application of U.S. Patent Application Ser. No. 15/853,076, and co-pending U.S. Patent Application Ser. No. 16/537,124, which is a continuation reissue application of U.S. Patent Application Ser. No. 15/853,076. --.

Signed and Sealed this
Seventeenth Day of September, 2019

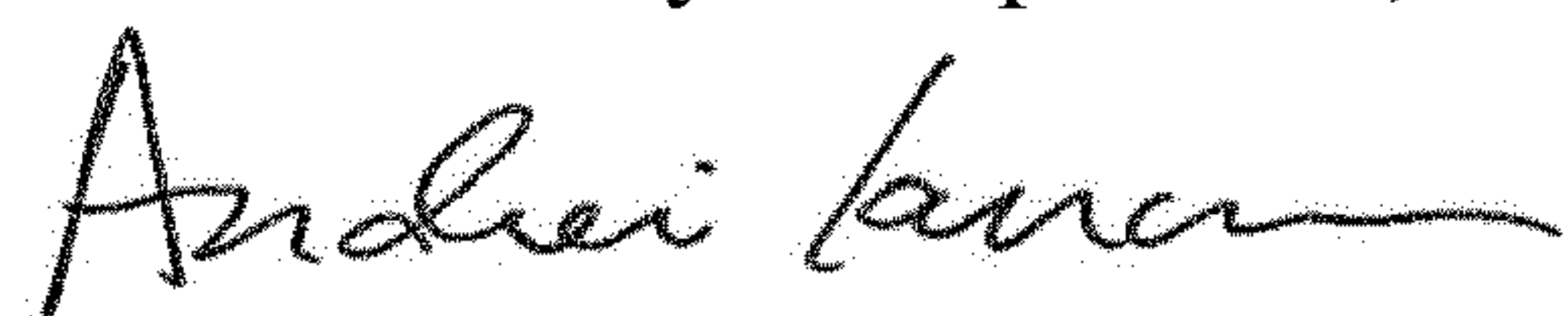

Andrei Iancu
Director of the United States Patent and Trademark Office