



US00RE46715E

(19) **United States**
(12) **Reissued Patent**
Veskovic

(10) **Patent Number: US RE46,715 E**
(45) **Date of Reissued Patent: Feb. 13, 2018**

(54) **FORWARD CONVERTER HAVING A PRIMARY-SIDE CURRENT SENSE CIRCUIT**

(56) **References Cited**

(71) Applicant: **Lutron Electronics Co., Inc.**,
Coopersburg, PA (US)

6,452,344 B1 9/2002 MacAdam et al.
6,982,528 B2 1/2006 Cottongim et al.

(Continued)

(72) Inventor: **Dragan Veskovic**, Allentown, PA (US)

FOREIGN PATENT DOCUMENTS

(73) Assignee: **Lutron Electronics Co., Inc.**,
Coopersburg, PA (US)

CN 102217418 A 10/2011
TW 2009-06041 A 2/2009

(21) Appl. No.: **15/347,484**

OTHER PUBLICATIONS

(22) Filed: **Nov. 9, 2016**

European Patent Office, International Search Report and Written Opinion for the International Application No. PCT/US2013/048740, dated May 28, 2014, 9 pages.

Related U.S. Patent Documents

Reissue of:

(64) Patent No.: **9,232,574**
Issued: **Jan. 5, 2016**
Appl. No.: **13/834,153**
Filed: **Mar. 15, 2013**

Primary Examiner — Angela M Lie

(74) *Attorney, Agent, or Firm* — Glen R. Farbanish;
Philip N. Smith

U.S. Applications:

(60) Provisional application No. 61/668,759, filed on Jul. 6, 2012.

(57) **ABSTRACT**

A load control device for controlling the amount of power delivered to an electrical load (e.g., an LED light source) comprises an isolated forward converter comprising a transformer, a controller, and a current sense circuit operable to receive a sense voltage representative of a primary current conducting through to a primary winding of the transformer. The primary winding is coupled in series with a semiconductor switch, while a secondary winding is adapted to be operatively coupled to the load. The forward converter comprises a sense resistor coupled in series with the primary winding for producing the sense voltage that is representative of the primary current. The current sense circuit receives the sense voltage and averages the sense voltage when the semiconductor switch is conductive, so as to generate a load current control signal that is representative of a real component of a load current conducted through the load.

(51) **Int. Cl.**
H05B 37/02 (2006.01)
H05B 33/08 (2006.01)
H02M 3/335 (2006.01)

(52) **U.S. Cl.**
CPC **H05B 33/0815** (2013.01); **H02M 3/33538**
(2013.01); **H02M 3/33546** (2013.01);
(Continued)

(58) **Field of Classification Search**
USPC 315/307, 291, 297
See application file for complete search history.

29 Claims, 11 Drawing Sheets

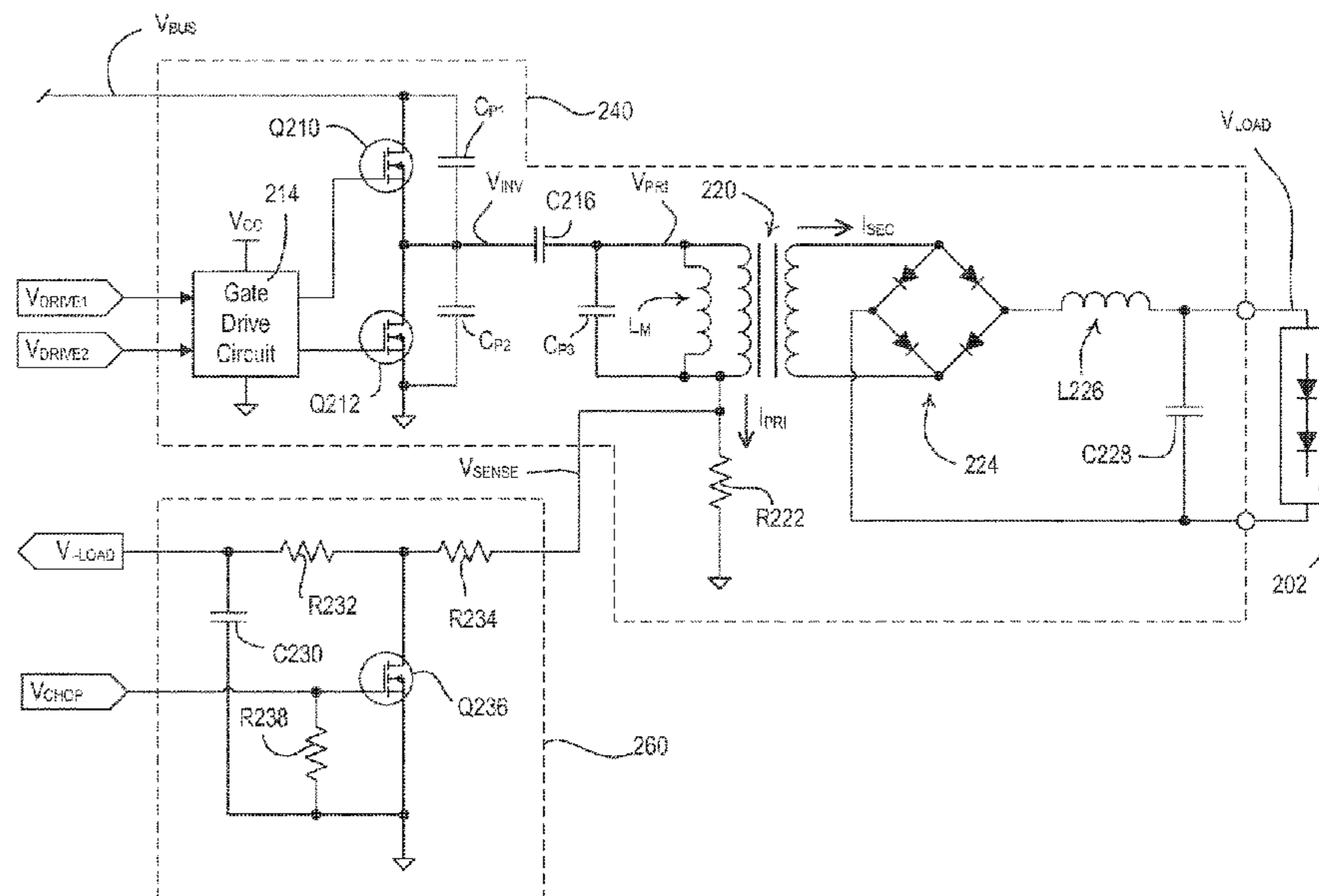

US RE46,715 E

(52) **U.S. Cl.**
 CPC **H02M 3/33553** (2013.01); **H05B 33/08**
 (2013.01); **H05B 33/0851** (2013.01); **Y02B**
 20/347 (2013.01)

(56) **References Cited**

U.S. PATENT DOCUMENTS

7,061,191	B2	6/2006	Chitta	
7,259,524	B2	8/2007	Hausman, Jr. et al.	
7,432,661	B2	10/2008	Taipale et al.	
7,489,090	B2	2/2009	Taipale	
7,825,609	B2	11/2010	Taipale et al.	
8,008,866	B2	8/2011	Newman, Jr. et al.	
8,228,002	B2	7/2012	Newman, Jr. et al.	
8,232,733	B2	7/2012	Newman, Jr. et al.	
8,339,048	B2	12/2012	Newman, Jr. et al.	
8,354,803	B2	1/2013	Newman, Jr. et al.	
8,354,804	B2	1/2013	Otake et al.	
8,384,297	B2	2/2013	Quayle et al.	
8,466,628	B2	6/2013	Shearer et al.	H05B 33/0815 315/209 R
8,492,987	B2	7/2013	Nuhfer et al.	
8,492,988	B2	7/2013	Nuhfer et al.	

9,220,138	B1*	12/2015	Zhang	H05B 33/0815
9,232,574	B2	1/2016	Veskovic	
9,240,727	B2*	1/2016	Sugawara	H02M 3/33507
9,484,832	B2*	11/2016	Melanson	H02M 1/44
2009/0034301	A1	2/2009	Chou	
2010/0123404	A1	5/2010	Chen et al.	
2010/0156319	A1	6/2010	Melanson	
2010/0244801	A1	9/2010	Arora et al.	
2011/0080110	A1	4/2011	Nuhfer et al.	
2011/0080111	A1	4/2011	Nuhfer et al.	
2011/0080112	A1	4/2011	Shearer et al.	
2011/0248648	A1	10/2011	Liu	
2011/0304276	A1*	12/2011	Hariharan	315/297
2011/0304280	A1*	12/2011	Jin	H05B 41/2825 315/307
2012/0043899	A1	2/2012	Veskovic	
2012/0043905	A1	2/2012	Christensen et al.	
2012/0153866	A1*	6/2012	Liu	315/294
2012/0286681	A1	11/2012	Hausman, Jr.	
2012/0286689	A1	11/2012	Newman, Jr. et al.	
2013/0018522	A1	1/2013	Nuhfer et al.	
2013/0020964	A1	1/2013	Nuhfer et al.	
2013/0049589	A1	2/2013	Simi	
2013/0063047	A1	3/2013	Veskovic	

* cited by examiner

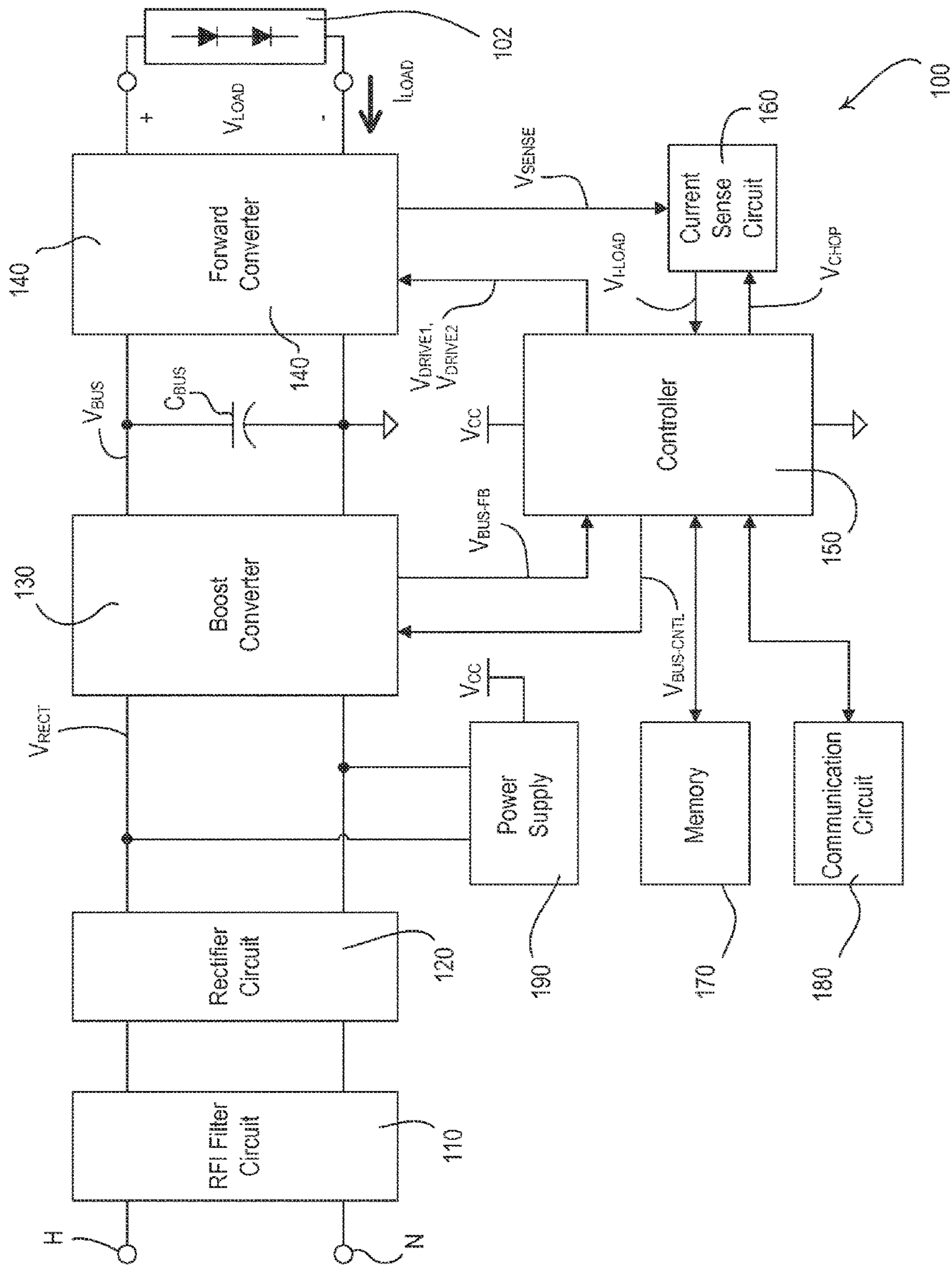

Fig. 1

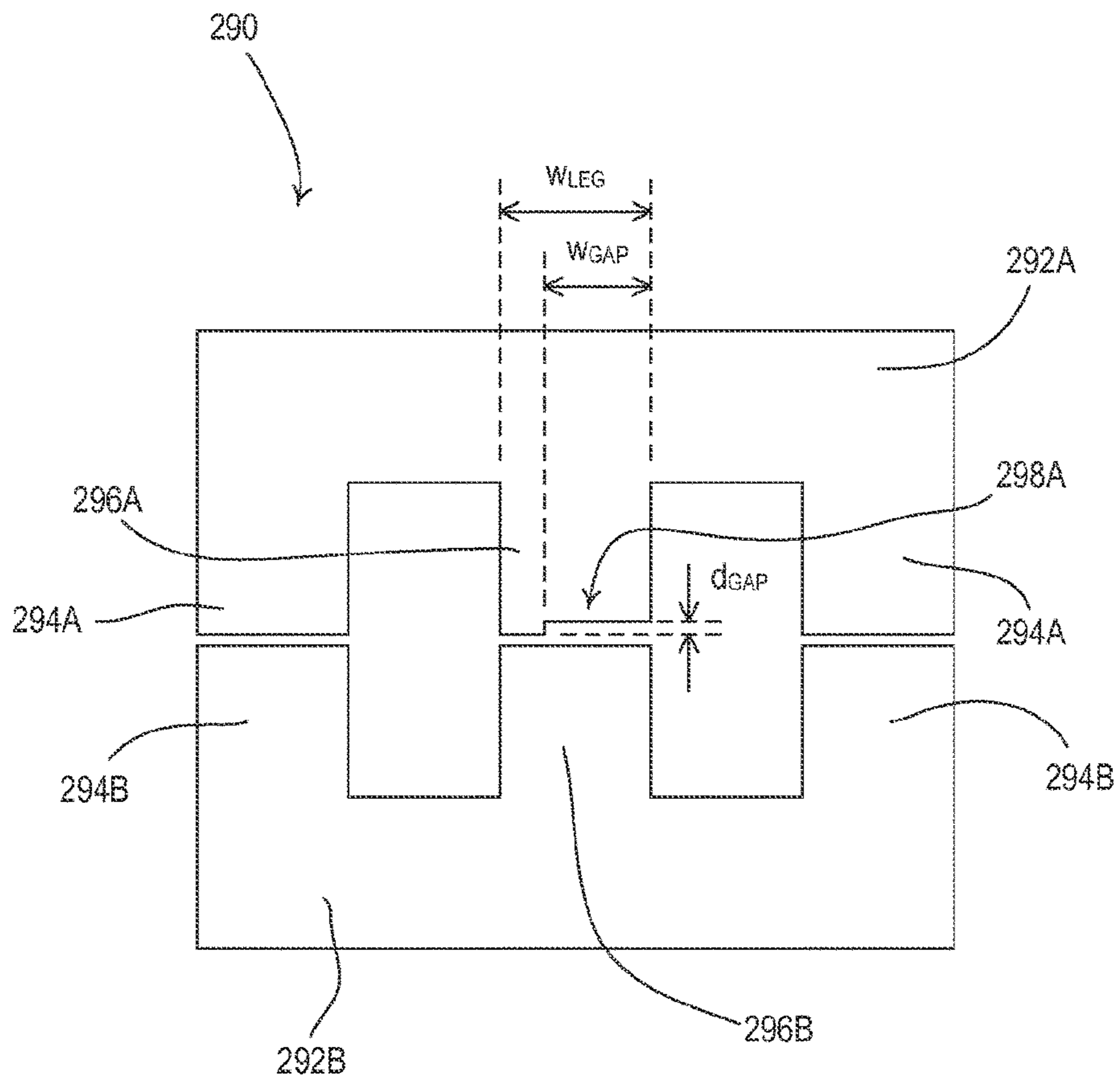

Fig. 3

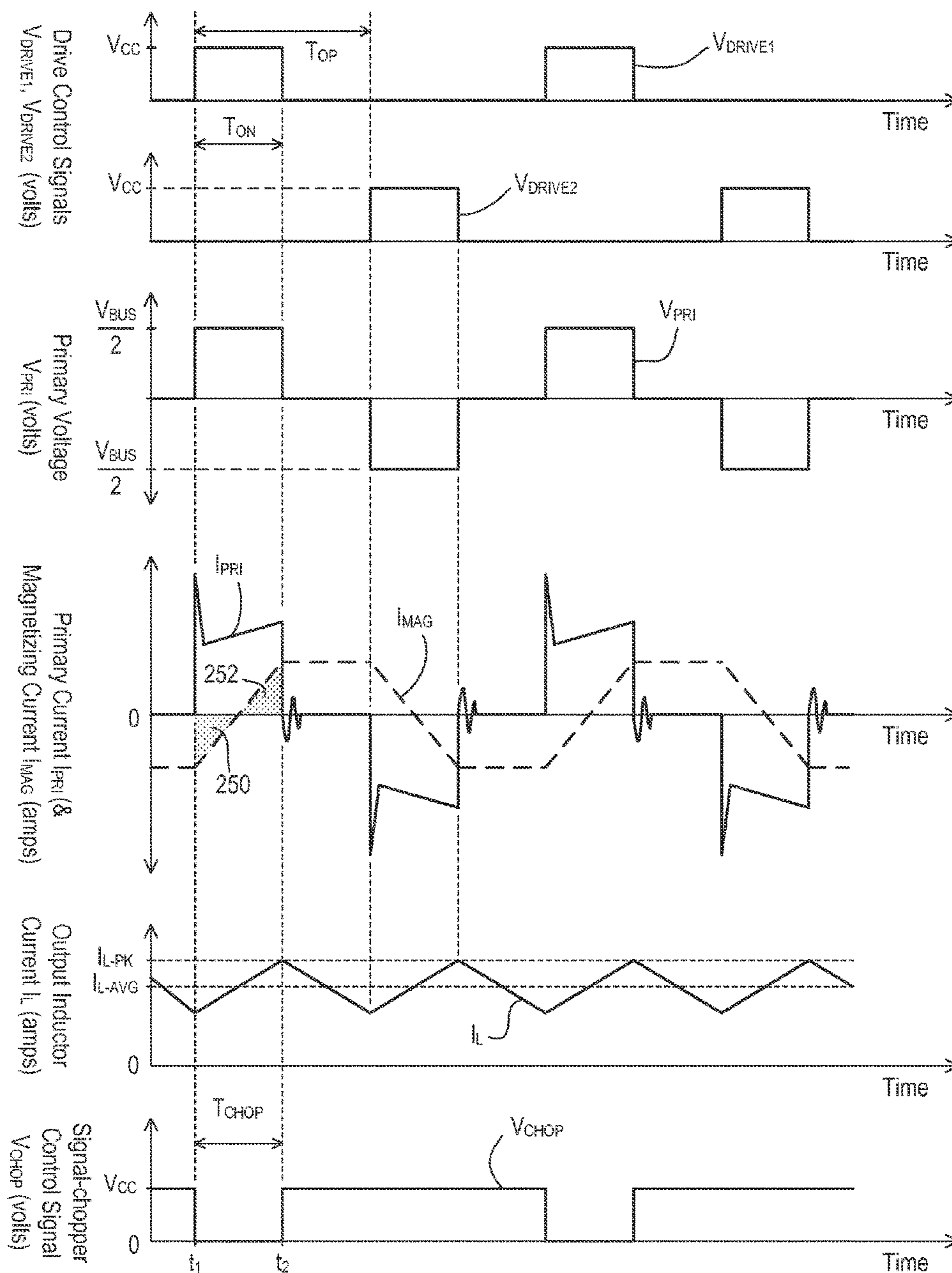

Fig. 4

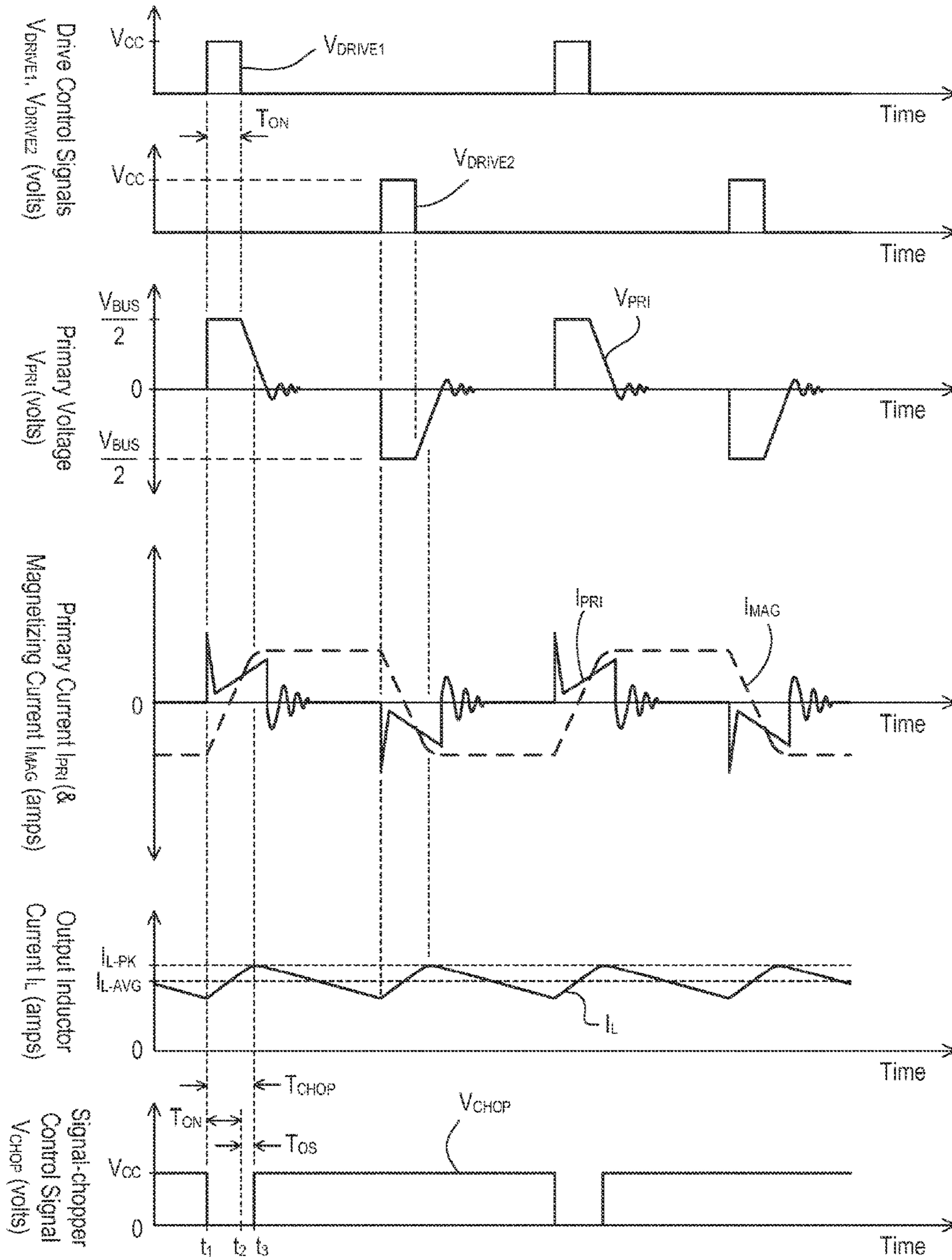

Fig. 5

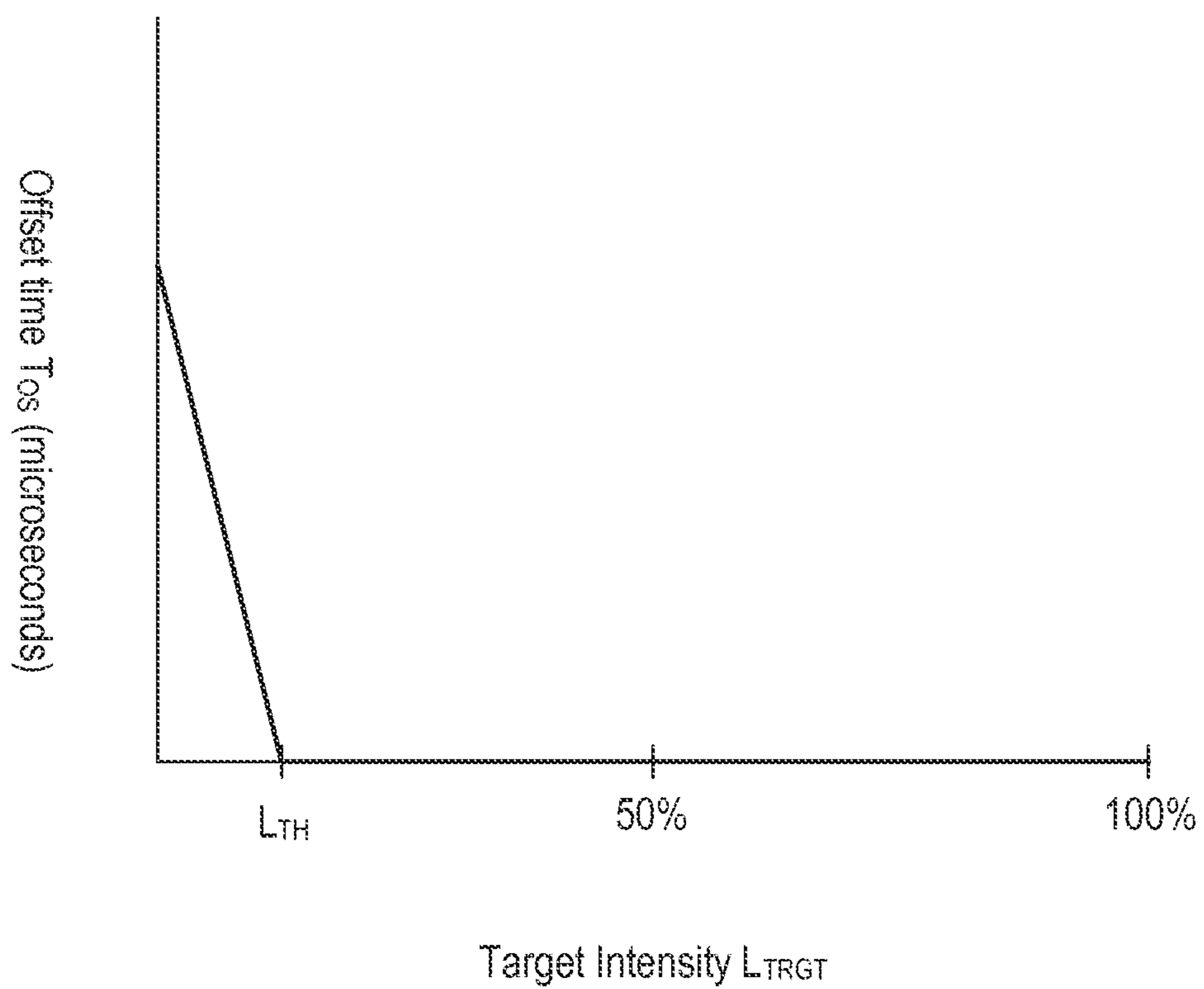

Fig. 6

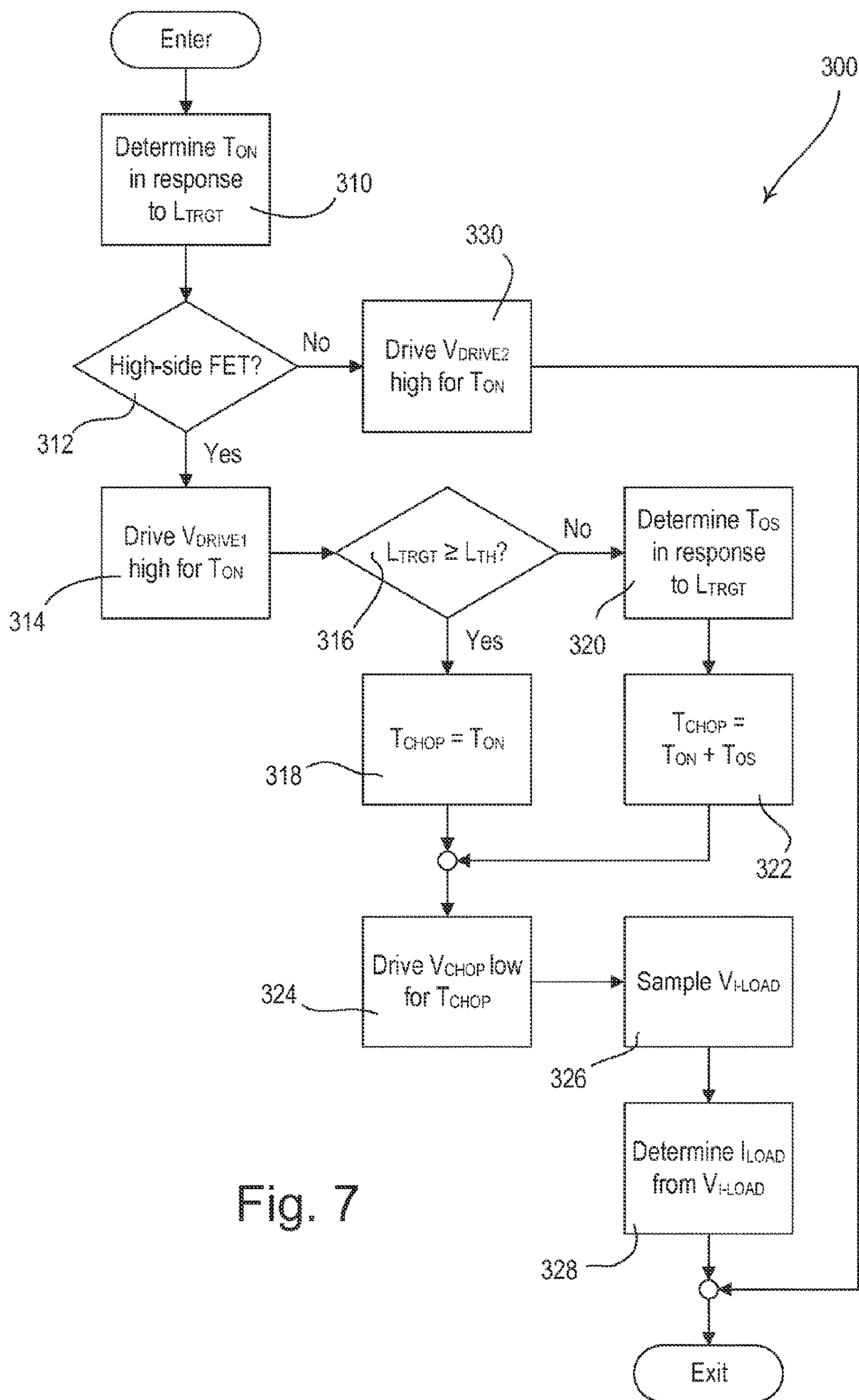

Fig. 7

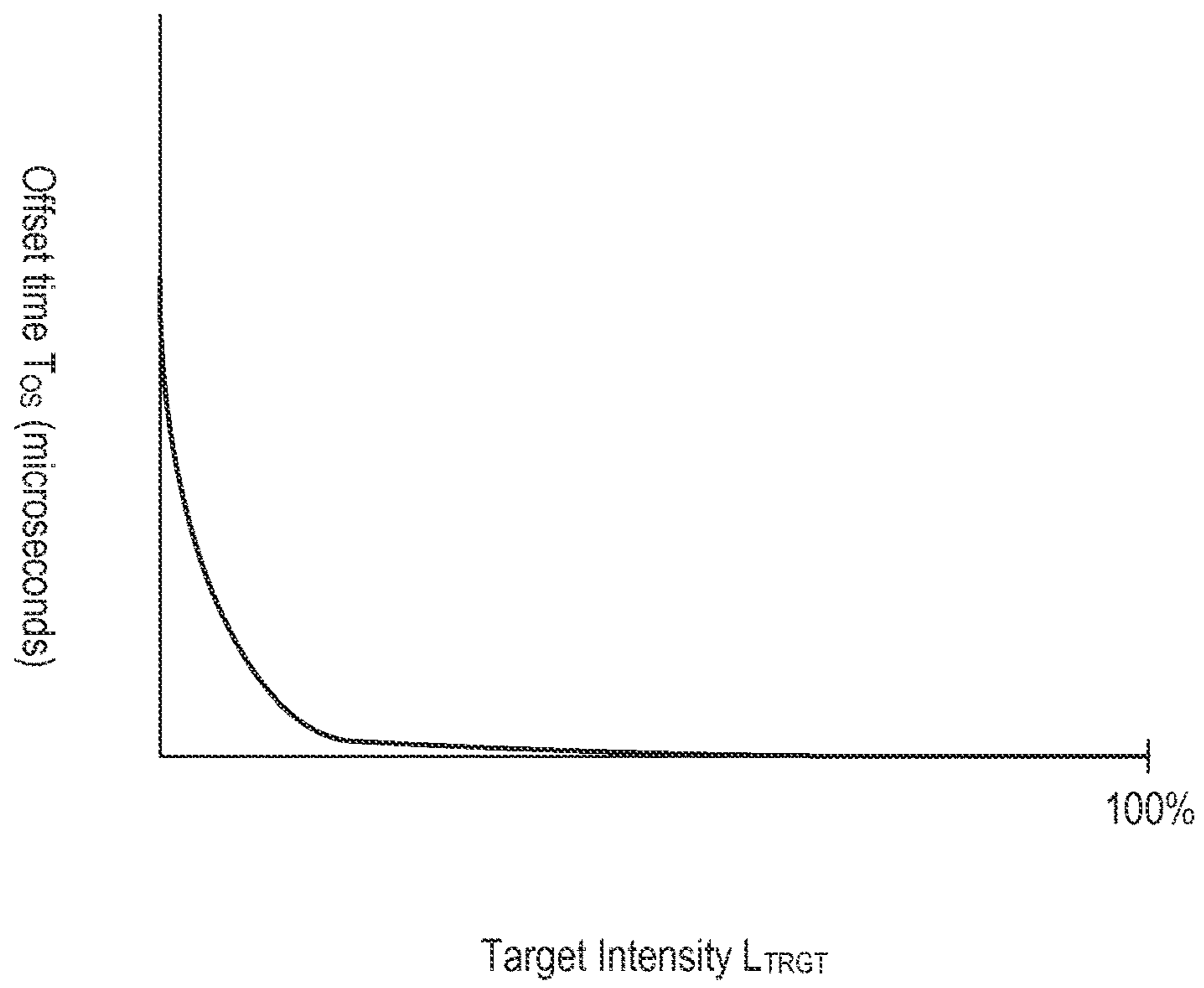

Fig. 8

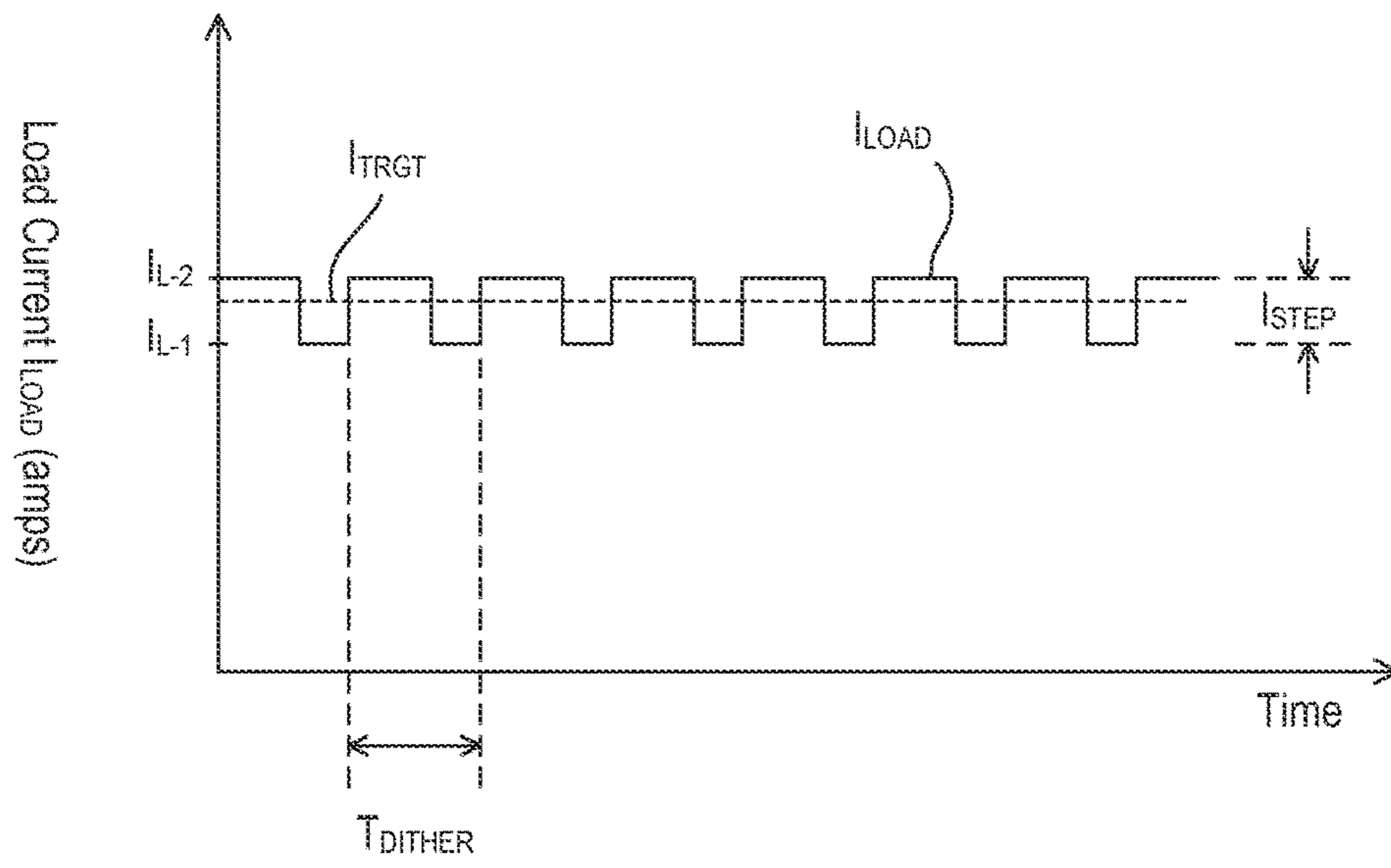

Fig. 9

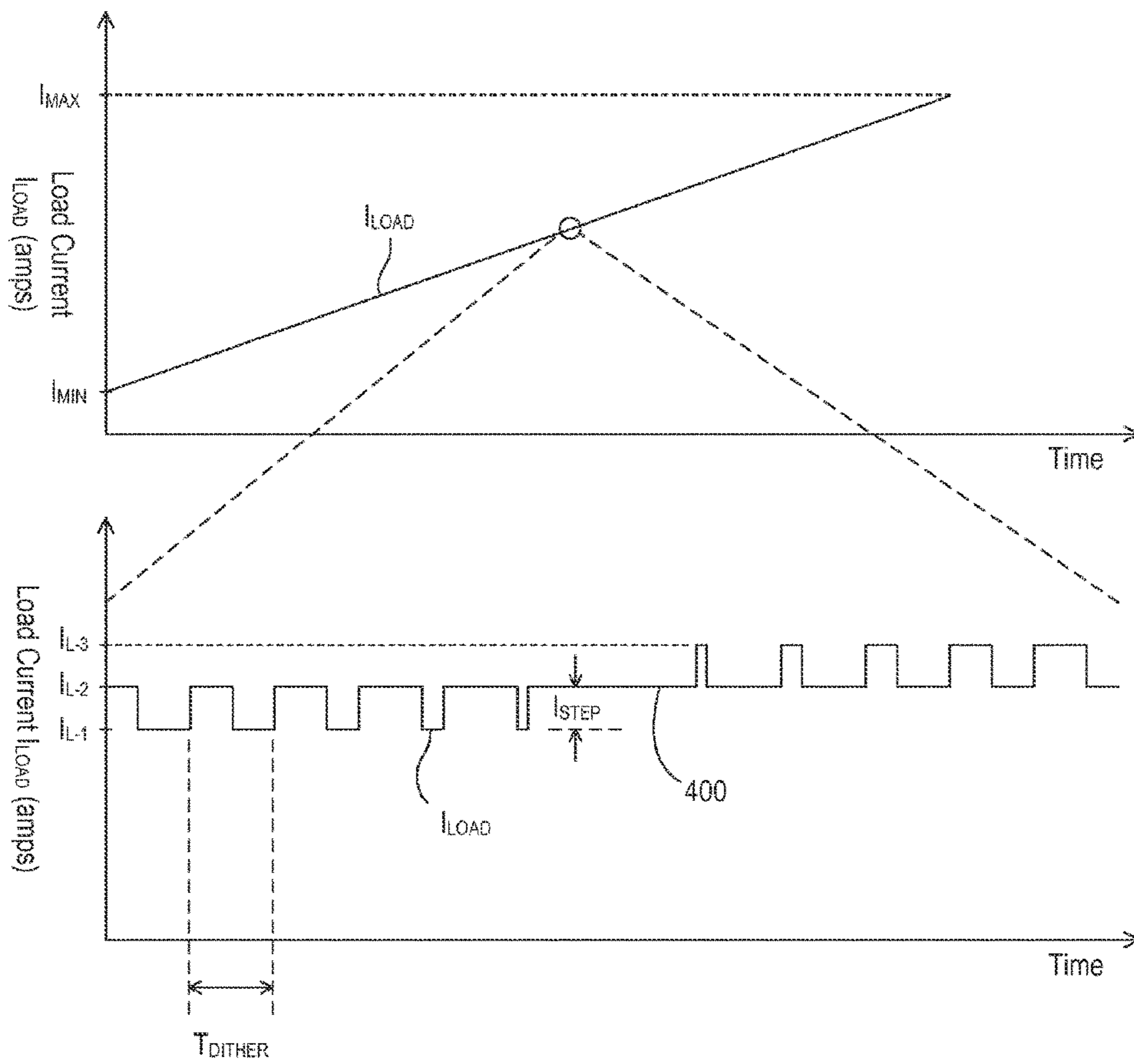

Fig. 10

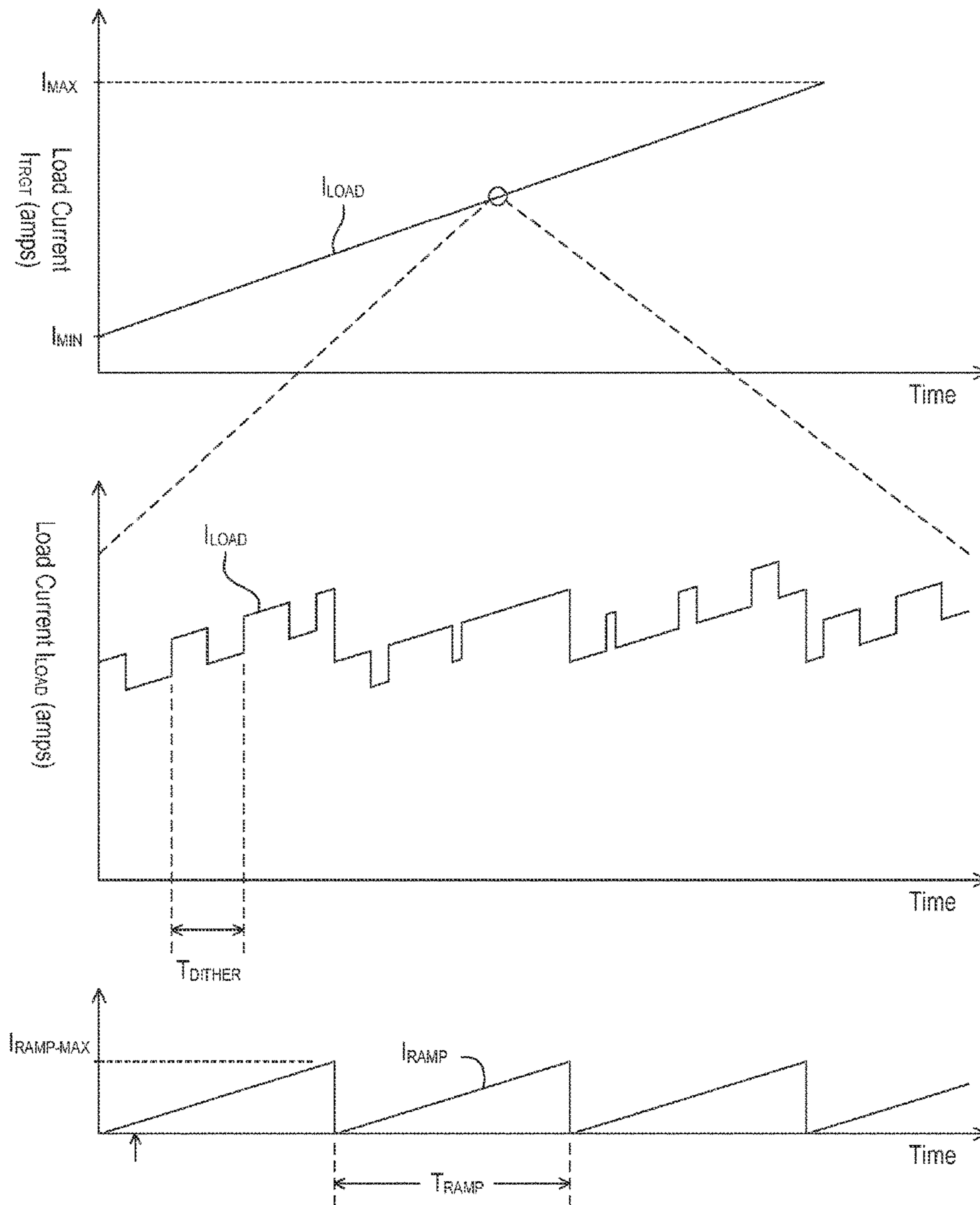

Fig. 11

FORWARD CONVERTER HAVING A PRIMARY-SIDE CURRENT SENSE CIRCUIT

Matter enclosed in heavy brackets [] appears in the original patent but forms no part of this reissue specification; matter printed in italics indicates the additions made by reissue; a claim printed with strikethrough indicates that the claim was canceled, disclaimed, or held invalid by a prior post-patent action or proceeding.

CROSS-REFERENCE TO RELATED APPLICATIONS

This application is *an application for reissue of U.S. Pat. No. 9,232,574, which was granted on U.S. patent application Ser. No. 13/834,153, which is a non-provisional application of commonly-assigned U.S. Provisional Application No. 61/668,759, filed Jul. 6, 2012, entitled LOAD CONTROL DEVICE FOR A LIGHT-EMITTING DIODE LIGHT SOURCE*, the entire disclosure of which is hereby incorporated by reference.

BACKGROUND OF THE INVENTION

1. Field of the Invention

The present invention relates to a load control device for a light-emitting diode (LED) light source, and more particularly, to an LED driver for controlling the intensity of an LED light source.

2. Description of the Related Art

Light-emitting diode (LED) light sources (i.e., LED light engines) are often used in place of or as replacements for conventional incandescent, fluorescent, or halogen lamps, and the like. LED light sources may comprise a plurality of light-emitting diodes mounted on a single structure and provided in a suitable housing. LED light sources are typically more efficient and provide longer operational lives as compared to incandescent, fluorescent, and halogen lamps. In order to illuminate properly, an LED driver control device (i.e., an LED driver) must be coupled between an alternating-current (AC) source and the LED light source for regulating the power supplied to the LED light source. The LED driver may regulate either the voltage provided to the LED light source to a particular value, the current supplied to the LED light source to a specific peak current value, or may regulate both the current and voltage.

LED light sources are typically rated to be driven via one of two different control techniques: a current load control technique or a voltage load control technique. An LED light source that is rated for the current load control technique is also characterized by a rated current (e.g., approximately 350 milliamperes) to which the peak magnitude of the current through the LED light source should be regulated to ensure that the LED light source is illuminated to the appropriate intensity and color. In contrast, an LED light source that is rated for the voltage load control technique is characterized by a rated voltage (e.g., approximately 15 volts) to which the voltage across the LED light source should be regulated to ensure proper operation of the LED light source. Typically, each string of LEDs in an LED light source rated for the voltage load control technique includes a current balance regulation element to ensure that each of the parallel legs has the same impedance so that the same current is drawn in each parallel string.

It is known that the light output of an LED light source can be dimmed. Different methods of dimming LEDs

include a pulse-width modulation (PWM) technique and a constant current reduction (CCR) technique. Pulse-width modulation dimming can be used for LED light sources that are controlled in either a current or voltage load control mode. In pulse-width modulation dimming, a pulsed signal with a varying duty cycle is supplied to the LED light source. If an LED light source is being controlled using the current load control technique, the peak current supplied to the LED light source is kept constant during an on time of the duty cycle of the pulsed signal. However, as the duty cycle of the pulsed signal varies, the average current supplied to the LED light source also varies, thereby varying the intensity of the light output of the LED light source. If the LED light source is being controlled using the voltage load control technique, the voltage supplied to the LED light source is kept constant during the on time of the duty cycle of the pulsed signal in order to achieve the desired target voltage level, and the duty cycle of the load voltage is varied in order to adjust the intensity of the light output. Constant current reduction dimming is typically only used when an LED light source is being controlled using the current load control technique. In constant current reduction dimming, current is continuously provided to the LED light source, however, the DC magnitude of the current provided to the LED light source is varied to thus adjust the intensity of the light output. Examples of LED drivers are described in greater detail in commonly-assigned U.S. patent application Ser. No. 12/813,908, filed Jun. 11, 2010, and U.S. patent application Ser. No. 13/416,741, filed Mar. 9, 2012, both entitled *LOAD CONTROL DEVICE FOR A LIGHT-EMITTING DIODE LIGHT SOURCE*, the entire disclosures of which are hereby incorporated by reference.

In addition, some LED light sources comprise forward converters for driving the LED light sources to control the load current conducted through the LED light source. Forward converters comprise a transformer having a primary winding coupled to at least one semiconductor switch and a secondary winding operatively coupled to the LED light source. The semiconductor switch is rendered conductive and non-conductive to conduct a primary current through the primary winding and to thus transfer power to the secondary winding of the transformer. Forward converters typically comprise an optocoupler for coupling a feedback signal on the secondary side of the transformer to the primary side of the transformer, such that a controller can control the semiconductor switch in response to the feedback signal. However, there is a need for a forward converter that is able to control the magnitude of the load current through an LED light source without the need for an optocoupler.

SUMMARY OF THE INVENTION

As described herein, a load control device for controlling the amount of power delivered to an electrical load may comprise an isolated forward converter, a controller, and/or a current sense circuit. The forward converter may be operable to receive a bus voltage and to conduct a load current through the electrical load. The forward converter may comprise a transformer that includes a primary winding. The primary winding of the transformer may be coupled in series with a first semiconductor switch, while a secondary winding is adapted to be operatively coupled to the electrical load. The forward converter may comprise a half-bridge inverter may comprise the first semiconductor switch and a second semiconductor switch coupled in series across the bus voltage for generating an inverter voltage at a junction of the two semiconductor switches. The junction

of the two semiconductor switches may be coupled to the primary winding of the transformer through a capacitor, for example, such that a primary voltage across the primary winding has a positive polarity when the first semiconductor switch is conductive and has a negative polarity when the second semiconductor switch is conductive. The transformer may be operable to transfer power to the secondary winding when either of the semiconductor switches is conductive. The forward converter may further comprise a sense resistor coupled in series with the primary winding for producing a sense voltage that is representative of the primary current conducted through the primary winding. The controller may be coupled to the forward converter for controlling the first semiconductor switch to control the load current conducted through the electrical load. The current sense circuit may be operable to receive the sense voltage. The current sense circuit may comprise an averaging circuit for averaging the sense voltage when the first semiconductor switch of the forward converter is conductive, so as to generate a load current control signal that is representative of a real component of the primary current.

An LED driver for controlling the intensity of an LED light source is also described herein. The LED driver may comprise an isolated forward converter, a controller, and a current sense circuit. The forward converter may be operable to receive a bus voltage and to conduct a load current through the electrical load. The forward converter may comprise a transformer having a primary winding and a secondary winding adapted to be operatively coupled to the LED light source. The forward converter may further comprise a half-bridge inverter circuit for generating an inverter voltage that is coupled to the primary winding of the transformer through a capacitor for producing a primary voltage across the primary winding. The forward converter may further comprise a sense resistor coupled in series with the primary winding for producing a sense voltage representative of a primary current conducted through the primary winding. The controller may be coupled to the forward converter for controlling the half-bridge inverter circuit to control the load current conducted through the LED light source to control the intensity of the LED light source to a target intensity. The current sense circuit may be operable to receive the sense voltage and to average the sense voltage when the magnitude of the primary voltage across the primary winding is positive and greater than approximately zero volts, so as to generate a load current control signal that is representative of a real component of the primary current.

In addition, a forward converter for controlling the amount of power delivered to an electrical load from an input voltage, as described herein, may comprise one or more of: (1) a transformer having a primary winding and a secondary winding adapted to be operatively coupled to the electrical load; (2) a half-bridge inverter circuit including first and second semiconductor switches coupled in series across the input voltage for generating an inverter voltage at the junction of the two semiconductor switches; (3) a capacitor coupled between the junction of the two semiconductor switches of the half-bridge inverter circuit and the primary winding of the transformer, such that a primary voltage is produced across the primary winding, the transformer operable to transfer power to the secondary winding when either of the semiconductor switches is conductive; (4) a controller coupled to the half-bridge inverter circuit for controlling the first and second semiconductor switches to control a load current conducted through the electrical load; (5) a sense resistor coupled in series with the primary winding for producing a sense voltage representative of a

primary current conducted through the primary winding; and/or (6) a current sense circuit operable to receive the sense voltage and to average the sense voltage when the first semiconductor switch of the half-bridge inverter circuit is conductive, so as to generate a load current control signal that is representative of a real component of the primary current.

A load control device for controlling the amount of power delivered to an electrical load may comprise an isolated forward converter, a controller, and/or a current sense circuit. The forward converter may be operable to receive a bus voltage and to conduct a load current through the electrical load. The forward converter may comprise a transformer that includes a primary winding. The primary winding of the transformer may be coupled in series with a first semiconductor switch, while a secondary winding is adapted to be operatively coupled to the electrical load. The forward converter may further comprise a sense resistor coupled in series with the primary winding for producing a sense voltage that is representative of the primary current conducted through the primary winding. The controller may be coupled to the forward converter for controlling the first semiconductor switch to control the magnitude of the load current conducted through the electrical load to control the amount of power delivered to the electrical load to a target amount of power. The current sense circuit may be operable to receive the sense voltage and average the sense voltage when the first semiconductor switch of the forward converter is conductive, so as to generate a load current control signal that is representative of a real component of the primary current. For example, the current sense circuit may be operable to average the sense voltage for an on time when the first semiconductor switch of the forward converter is conductive plus an addition amount of time, so as to generate the load current control signal that is representative of the real component of the primary current.

Other features and advantages of the present invention will become apparent from the following description of the invention that refers to the accompanying drawings.

BRIEF DESCRIPTION OF THE DRAWINGS

FIG. 1 is a simplified block diagram of a light-emitting diode (LED) driver for controlling the intensity of an LED light source.

FIG. 2 is a simplified schematic diagram of an isolated forward converter and a current sense circuit of an LED driver.

FIG. 3 is an example diagram illustrating a magnetic core set of an energy-storage inductor of a forward converter.

FIG. 4 shows example waveforms illustrating the operation of a forward converter and a current sense circuit when the intensity of an LED light source is near a high-end intensity.

FIG. 5 shows example waveforms illustrating the operation of a forward converter and a current sense circuit when the intensity of an LED light source is near a low-end intensity.

FIG. 6 is an example plot of a relationship between an offset time and a target intensity of an LED driver.

FIG. 7 is a simplified flowchart of a control procedure executed periodically by a controller of an LED driver.

FIG. 8 is an example plot of a relationship between the offset time and the target intensity of an LED driver.

FIG. 9 shows an example waveform of a load current conducted through an LED light source when a target current of an LED driver is at a steady-state value.

5

FIG. 10 shows an example waveform of the load current conducted through the LED light source when the target current of the LED driver is being increased with respect to time.

FIG. 11 shows example waveforms of a ramp signal of an LED driver and a load current conducted through an LED light source when the ramp signal is added to a target current.

DETAILED DESCRIPTION OF THE
INVENTION

The foregoing summary, as well as the following detailed description of the preferred embodiments, is better understood when read in conjunction with the appended drawings. For the purposes of illustrating the invention, there is shown in the drawings an embodiment that is presently preferred, in which like numerals represent similar parts throughout the several views of the drawings, it being understood, however, that the invention is not limited to the specific methods and instrumentalities disclosed.

FIG. 1 is a simplified block diagram of a light-emitting diode (LED) driver 100 for controlling the intensity of an LED light source 102 (e.g., an LED light engine). The LED light source 102 is shown as a plurality of LEDs connected in series but may comprise a single LED or a plurality of LEDs connected in parallel or a suitable combination thereof, depending on the particular lighting system. In addition, the LED light source 102 may alternatively comprise one or more organic light-emitting diodes (OLEDs). The LED driver 100 comprises a hot terminal H and a neutral terminal that are adapted to be coupled to an alternating-current (AC) power source (not shown).

The LED driver 100 comprises a radio-frequency (RFI) filter circuit 110 for minimizing the noise provided on the AC mains and a rectifier circuit 120 for generating a rectified voltage V_{RECT} . The LED driver 100 further comprises a boost converter 130, which receives the rectified voltage V_{RECT} and generates a boosted direct-current (DC) bus voltage V_{BUS} across a bus capacitor C_{BUS} . The boost converter 130 may alternatively comprise any suitable power converter circuit for generating an appropriate bus voltage, such as, for example, a flyback converter, a single-ended primary-inductor converter (SEPIC), a Ćuk converter, or other suitable power converter circuit. The boost converter 120 may also operate as a power factor correction (PFC) circuit to adjust the power factor of the LED driver 100 towards a power factor of one. The LED driver 100 also comprises an isolated, half-bridge forward converter 140, which receives the bus voltage V_{BUS} and controls the amount of power delivered to the LED light source 102 so as to control the intensity of the LED light source between a low-end (i.e., minimum) intensity L_{LE} (e.g., approximately 1-5%) and a high-end (i.e., maximum) intensity L_{HE} (e.g., approximately 100%).

The LED driver 100 further comprises a control circuit, e.g., a controller 150, for controlling the operation of the boost converter 130 and the forward converter 140. The controller 150 may comprise, for example, a digital controller or any other suitable processing device, such as, for example, a microcontroller, a programmable logic device (PLD), a microprocessor, an application specific integrated circuit (ASIC), or a field-programmable gate array (FPGA). The controller 150 generates a bus voltage control signal $V_{BUS-CNTL}$, which is provided to the boost converter 130 for adjusting the magnitude of the bus voltage V_{BUS} . The controller 150 receives from the boost converter 130 a bus

6

voltage feedback control signals V_{BUS-FB} , which is representative of the magnitude of the bus voltage V_{BUS} .

The controller 150 also generates drive control signals V_{DRIVE1} , V_{DRIVE2} , which are provided to the forward converter 140 for adjusting the magnitude of a load voltage V_{LOAD} generated across the LED light source 102 and the magnitude of a load current I_{LOAD} conducted through the LED light source to thus control the intensity of the LED light source to a target intensity L_{TRGT} . The LED driver 100 further comprises a current sense circuit 160, which is responsive to a sense voltage V_{SENSE} that is generated by the forward converter 140 and is representative of the magnitude of the load current I_{LOAD} . The current sense circuit 160 is responsive to a signal-chopper control signal V_{CHOP} (which is received from the controller 150), and generates a load current feedback signal V_{I-LOAD} (which is a DC voltage representative of the magnitude of the load current I_{LOAD}). The controller 150 receives the load current feedback signal V_{I-LOAD} from the current sense circuit 160 and controls the drive control signals V_{DRIVE1} , V_{DRIVE2} to adjust the magnitude of the load current I_{LOAD} to a target load current I_{TRGT} to thus control the intensity of the LED light source 102 to the target intensity L_{TRGT} . The target load current I_{TRGT} may be adjusted between a minimum load current I_{MIN} and a maximum load current I_{MAX} .

The controller 150 is coupled to a memory 170 for storing the operational characteristics of the LED driver 100 (e.g., the target intensity L_{TRGT} , the low-end intensity L_{LE} , the high-end intensity L_{HE} , etc.). The LED driver 100 may also comprise a communication circuit 180, which may be coupled to, for example, a wired communication link or a wireless communication link, such as a radio-frequency (RF) communication link or an infrared (IR) communication link. The controller 150 may be operable to update the target intensity L_{TRGT} of the LED light source 102 or the operational characteristics stored in the memory 170 in response to digital messages received via the communication circuit 180. Alternatively, the LED driver 100 could be operable to receive a phase-control signal from a dimmer switch for determining the target intensity L_{TRGT} for the LED light source 102. The LED driver 100 further comprises a power supply 190, which receives the rectified voltage V_{RECT} and generates a direct-current (DC) supply voltage V_{CC} for powering the circuitry of the LED driver.

FIG. 2 is a simplified schematic diagram of a forward converter 240 and a current sense circuit 260, e.g., the forward converter 140 and the current sense circuit 160 of the LED driver 100 shown in FIG. 1. The forward converter 240 comprises a half-bridge inverter circuit having two field effect transistors (FETs) Q210, Q212 for generating a high-frequency inverter voltage V_{INV} from the bus voltage V_{BUS} . The FETs Q210, Q212 are rendered conductive and non-conductive in response to the drive control signals V_{DRIVE1} , V_{DRIVE2} , which are received from a controller (e.g., the controller 150). The drive control signals V_{DRIVE1} , V_{DRIVE2} are coupled to the gates of the respective FETs Q210, Q212 via a gate drive circuit 214 (e.g., part number L6382DTR, manufactured by ST Microelectronics). The controller generates the inverter voltage V_{INV} at a constant operating frequency f_{OP} (e.g., approximately 60-65 kHz) and thus a constant operating period T_{OP} . However, the operating frequency f_{OP} may be adjusted under certain operating conditions. The controller adjusts the duty cycle DC of the inverter voltage V_{INV} to adjust the magnitude of the load current I_{LOAD} and thus the intensity of an LED light source 202. The forward converter 240 may be characterized by a turn-on time $T_{TURN-ON}$ from when the drive control signals

V_{DRIVE1} , V_{DRIVE2} are driven high until the respective FET Q210, Q212 is rendered conductive, and a turn-off time $T_{TURN-OFF}$ from when the drive control signals V_{DRIVE1} , V_{DRIVE2} are driven low until the respective FET Q210, Q212 is rendered non-conductive.

The inverter voltage V_{INV} is coupled to the primary winding of a transformer 220 through a DC-blocking capacitor C216 (e.g., having a capacitance of approximately 0.047 μ F), such that a primary voltage V_{PRI} is generated across the primary winding. The transformer 220 is characterized by a turns ratio n_{TURNS} (i.e., N_1/N_2) of approximately 115:29. The sense voltage V_{SENSE} is generated across a sense resistor R222, which is coupled series with the primary winding of the transformer 220. The FETs Q210, Q212 and the primary winding of the transformer 220 are characterized by parasitic capacitances C_{P1} , C_{P2} , C_{P3} .

The secondary winding of the transformer 220 generates a secondary voltage, which is coupled to the AC terminals of a full-wave diode rectifier bridge 224 for rectifying the secondary voltage generated across the secondary winding. The positive DC terminal of the rectifier bridge 224 is coupled to the LED light source 202 through an output energy-storage inductor L226 (e.g., having an inductance of approximately 10 mH), such that the load voltage V_{LOAD} is generated across an output capacitor C228 (e.g., having a capacitance of approximately 3 μ F).

FIG. 3 is an example diagram illustrating a magnetic core set 290 of an energy-storage inductor (e.g., the output energy-storage inductor L226 of the forward converter 240 shown in FIG. 2). The magnetic core set 290 comprises two E-cores 292A, 292B, and may comprise part number PC40EE16-Z, manufactured by TDK Corporation. The E-cores 292A have respective outer legs 294A, 294B and inner legs 296A, 296B. Each inner leg 296A, 296B may have a width w_{LEG} (e.g., approximately 4 mm). The inner leg 296A of the first E-core 292A has a partial gap 298A (i.e., the magnetic core set 290 is partially-gapped), such that the inner legs 296A, 296B are spaced apart by a gap distance d_{GAP} (e.g., approximately 0.5 mm). The partial gap 298A may extend for a gap width W_{GAP} , e.g., approximately 2.8 mm, such that the gap extends for approximately 70% of the leg width w_{LEG} of the inner leg 296A. Alternatively, both of the inner legs 296A, 296B could comprise partial gaps. The partially-gapped magnetic core set 290 shown in FIG. 3 allows the output energy-storage inductor L226 of the forward converter 240 shown in FIG. 2 to maintain continuous current at low load conditions (e.g., near the low-end intensity L_{LE}).

FIG. 4 shows example waveforms illustrating the operation of a forward converter and a current sense circuit, e.g., the forward converter 240 and the current sense circuit 260 shown in FIG. 2. The controller drives the respective drive control signals V_{DRIVE1} , V_{DRIVE2} high to approximately the supply voltage V_{CC} to render the respective FETs Q210, Q212 conductive for an on time T_{ON} at different times (i.e., the FETs Q210, Q212 are not conductive at the same time). When the high-side FET Q210 is conductive, the primary winding of the transformer 220 conducts a primary current I_{PRI} to circuit common through the capacitor C216 and sense resistor R222. Immediately after the high-side FET Q210 is rendered conductive (at time t_1 in FIG. 4), the primary current I_{PRI} conducts a short high-magnitude pulse of current due to the parasitic capacitance C_{P3} of the transformer 220 as shown in FIG. 4. While the high-side FET Q210 is conductive, the capacitor C216 charges, such that a voltage having a magnitude of approximately half of the magnitude of the bus voltage V_{BUS} is developed across the capacitor.

Accordingly, the magnitude of the primary voltage V_{PRI} across the primary winding of the transformer 220 is approximately equal to approximately half of the magnitude of the bus voltage V_{BUS} . When the low-side FET Q212 is conductive, the primary winding of the transformer 220 conducts the primary current I_{PRI} in an opposite direction and the capacitor C216 is coupled across the primary winding, such that the primary voltage V_{PRI} has a negative polarity with a magnitude equal to approximately half of the magnitude of the bus voltage V_{BUS} .

When either of the high-side and low-side FETs Q210, Q212 are conductive, the magnitude of an output inductor current I_L conducted by the output inductor L226 and the magnitude of the load voltage V_{LOAD} across the LED light source 202 both increase with respect to time. The magnitude of the primary current I_{PRI} also increases with respect to time while the FETs Q210, Q212 are conductive (after the initial current spike). When the FETs Q210, Q212 are non-conductive, the output inductor current I_L and the load voltage V_{LOAD} both decrease in magnitude with respect to time. The output inductor current I_L is characterized by a peak magnitude I_{L-PK} and an average magnitude I_{L-AVG} as shown in FIG. 4. The controller increases and decreases the on times T_{ON} of the drive control signals V_{DRIVE1} , V_{DRIVE2} (and the duty cycle DC of the inverter voltage V_{INV}) to respectively increase and decrease the average magnitude I_{L-AVG} of the output inductor current I_L and thus respectively increase and decrease the intensity of the LED light source 102.

When the FETs Q210, Q212 are rendered non-conductive, the magnitude of the primary current I_{PRI} drops toward zero amps (e.g., as shown at time t_2 in FIG. 4 when the high-side FET Q210 is rendered non-conductive). However, current may continue to flow through the primary winding of the transformer 220 due to the magnetizing inductance L_{MAG} of the transformer (which conducts a magnetizing current I_{MAG}). In addition, when the target intensity L_{TRGT} of the LED light source 102 is near the low-end intensity L_{LE} , the magnitude of the primary current I_{PRI} oscillates after either of the FETs Q210, Q212 is rendered non-conductive due to the parasitic capacitances C_{P1} , C_{P2} of the FETs, the parasitic capacitance C_{P3} of the primary winding of the transformer 220, and any other parasitic capacitances of the circuit, such as, parasitic capacitances of the printed circuit board on which the forward converter 240 is mounted.

The real component of the primary current I_{PRI} is representative of the magnitude of the secondary current I_{SEC} and thus the intensity of the LED light source 202. However, the magnetizing current I_{MAG} (i.e., the reactive component of the primary current I_{PRI}) also flows through the sense resistor R222. The magnetizing current I_{MAG} changes from negative to positive polarity when the high-side FET Q210 is conductive, changes from positive to negative polarity when the low-side FET Q212 is conductive, and remains constant when the magnitude of the primary voltage V_{PRI} is zero volts as shown in FIG. 4. The magnetizing current I_{MAG} has a maximum magnitude defined by the following equation:

$$I_{MAG-MAX} = \frac{V_{BUS} T_{HC}}{4 \cdot L_{MAG}} \quad (\text{Equation 1})$$

where T_{HC} is the half-cycle period of the inverter voltage V_{INV} , i.e., $T_{HC} = T_{OP}/2$. As shown in FIG. 4, the areas 250, 252 are approximately equal, such that the average value of

the magnitude of the magnetizing current I_{MAG} when the magnitude of the primary voltage V_{PRI} is greater than approximately zero volts.

The current sense circuit **260** averages the primary current I_{PRI} during the positive cycles of the inverter voltage V_{INV} , i.e., when the high-side FET **Q210** is conductive. The load current feedback signal V_{I-LOAD} generated by the current sense circuit **260** has a DC magnitude that is the average value of the primary current I_{PRI} when the high-side FET **Q210** is conductive. Because the average value of the magnitude of the magnetizing current I_{MAG} is approximately zero when the high-side FET **Q210** is conductive, the load current feedback signal V_{I-LOAD} generated by the current sense circuit is representative of only the real component of the primary current I_{PRI} .

The current sense circuit **260** comprises an averaging circuit for producing the load current feedback signal V_{I-LOAD} . The averaging circuit may comprise a low-pass filter having a capacitor **C230** (e.g., having a capacitance of approximately 0.066 μ F) and a resistor **R232** (e.g., having a resistance of approximately 3.32 k Ω). The low-pass filter receives the sense voltage V_{SENSE} via a resistor **R234** (e.g., having resistances of approximately 1 Ω). The current sense circuit **160** further comprises a transistor **Q236** (e.g., a FET as shown in FIG. 2) coupled between the junction of the resistors **R232**, **R234** and circuit common. The gate of the transistor **Q236** is coupled to circuit common through a resistor **R238** (e.g., having a resistance of approximately 22 k Ω) and receives the signal-chopper control signal V_{CHOP} from the controller.

When the high-side FET **Q210** is rendered conductive, the controller drives the signal-chopper control signal V_{CHOP} low towards circuit common to render the transistor **Q236** non-conductive for a signal-chopper time T_{CHOP} , which is approximately equal to the on time T_{ON} of the high-side FET **Q210** as shown in FIG. 4. The capacitor **C230** is able to charge from the sense voltage V_{SENSE} through the resistors **R232**, **R234** while the signal-chopper control signal V_{CHOP} is low, such that the magnitude of the load current feedback signal V_{I-LOAD} is the average value of the primary current I_{PRI} and is thus representative of the real component of the primary current during the time when the high-side FET **Q210** is conductive. When the high-side FET **Q210** is not conductive, the controller **150** drives the signal-chopper control signal V_{CHOP} high to render the transistor **Q236** non-conductive. Accordingly, the controller is able to accurately determine the average magnitude of the load current I_{LOAD} from the magnitude of the load current feedback signal V_{I-LOAD} since the effects of the magnetizing current I_{MAG} and the oscillations of the primary current I_{PRI} on the magnitude of the load current feedback signal V_{I-LOAD} are reduced or eliminated completely.

As the target intensity L_{TRGT} of the LED light source **202** is decreased towards the low-end intensity L_{LE} (and the on times T_{ON} of the drive control signals V_{DRIVE1} , V_{DRIVE2} get smaller), the parasitic of the forward converter **140** (i.e., the parasitic capacitances C_{P1} , C_{P2} of the FETs, the parasitic capacitance C_{P3} of the primary winding of the transformer **220**, and other parasitic capacitances of the circuit) can cause the magnitude of the primary voltage V_{PRI} to slowly decrease towards zero volts after the FETs **Q210**, **Q212** are rendered non-conductive.

FIG. 5 shows example waveforms illustrating the operation of a forward converter and a current sense circuit (e.g., the forward converter **240** and the current sense circuit **260**) when the target intensity L_{TRGT} is near the low-end intensity L_{LE} . The gradual drop off in the magnitude of the primary

voltage V_{PRI} allows the primary winding to continue to conduct the primary current I_{PRI} , such that the transformer **220** continues to delivered power to the secondary winding after the FETs **Q210**, **Q212** are rendered non-conductive as shown in FIG. 5. In addition, the magnetizing current I_{MAG} continues to increase in magnitude. Accordingly, the controller **150** increases the signal-chopper time T_{CHOP} (during which the signal-chopper control signal V_{CHOP} is low) by an offset time T_{OS} when the target intensity L_{TRGT} of the LED light source **202** is near the low-end intensity L_{LE} . The controller may adjust the value of the offset time T_{OS} as a function of the target intensity L_{TRGT} of the LED light source **202** as shown in FIG. 6. For example, the controller may adjust the value of the offset time T_{OS} linearly with respect to the target intensity L_{TRGT} when the target intensity L_{TRGT} is below a threshold intensity L_{TH} (e.g., approximately 10%) as shown in FIG. 5.

FIG. 7 is a simplified flowchart of a control procedure **300** executed periodically by a controller (e.g., the controller **150** of the LED driver **100** shown in FIG. 1 and/or the controller controlling the forward converter **240** and the current sense circuit **260** shown in FIG. 2). The controller may execute the control procedure **300**, for example, at the operating period T_{OP} of the inverter voltage V_{INV} of the forward converter **240**. First, the controller determines the appropriate on time T_{ON} for the drive control signals V_{DRIVE1} , V_{DRIVE2} in response to the target intensity L_{TRGT} and the load current feedback signal V_{I-LOAD} at step **310**. If the controller should presently control the high-side FET **Q210** at step **312**, the controller drives the first drive control signal V_{DRIVE1} high to approximately the supply voltage V_{CC} for the on time T_{ON} at step **314**. If the target intensity L_{TRGT} is greater than or equal to the threshold intensity L_{TH} at step **316**, the controller **150** sets the signal-chopper time T_{CHOP} equal to the on time T_{ON} at step **318**. If the target intensity L_{TRGT} is less than the threshold intensity L_{TH} at step **316**, the controller determines the offset time T_{OS} in response to the target intensity L_{TRGT} at step **320** (e.g., using the relationship shown in FIG. 6), and sets the signal-chopper time T_{CHOP} equal to the sum of the on time T_{ON} and the offset time T_{OS} at step **322**.

Next, the controller drives the signal-chopper control signal V_{CHOP} low towards circuit common for the signal-chopper time T_{CHOP} at step **324**. The controller then samples the averaged load current feedback signal V_{I-LOAD} at step **326** and calculates the magnitude of the load current I_{LOAD} using the sampled value at step **328**, for example, using the following equation:

$$I_{LOAD} = \frac{n_{TURNS} \cdot V_{I-LOAD} \cdot T_{HC}}{R_{SENSE} \cdot (T_{CHOP} - T_{DELAY})} \quad (\text{Equation 2})$$

where T_{DELAY} is the total delay time due to the turn-on time and the turn-off time of the FETs **Q210**, **Q212**, e.g., $T_{DELAY} = T_{TURN-ON} + T_{TURN-OFF}$, which may be equal to approximately 200 μ sec. Finally, the control procedure **300** exits after the magnitude of the load current I_{LOAD} has been calculated. If the controller should presently control the low-side FET **Q210** at step **312**, the controller drives the second drive control signal V_{DRIVE2} high to approximately the supply voltage V_{CC} for the on time T_{ON} at step **330**, and the control procedure **300** exits without the controller driving the signal-chopper control signal V_{CHOP} low.

Alternatively, the controller can use a different relationship to determine the offset time T_{OS} throughout the entire dimming range of the LED light source (i.e., from the

low-end intensity I_{LE} to the high-end intensity I_{HE}) as shown in FIG. 8. For example, the controller could use the following equation:

$$T_{OS} = \frac{\frac{V_{BUS}}{4} \cdot C_{PARASITIC}}{\frac{T_{ON} + T_{OS-PREV}}{T_{HC}} \cdot I_{MAG-MAX} + \frac{K_{RIPPLE}}{n_{TURNS}} \cdot I_{LOAD}}, \quad (\text{Equation 3})$$

where $T_{OS-PREV}$ is the previous value of the offset time, K_{RIPPLE} is the dynamic ripple ratio of the output inductor current I_L (which is a function of the load current I_{LOAD}) i.e.,

$$K_{RIPPLE} = I_{L-PK} / I_{L-AVG}, \quad (\text{Equation 4})$$

and $C_{PARASITIC}$ is the total parasitic capacitance between the junction of the FETs Q210, Q212 and circuit common.

As previously mentioned, the controller increases and decreases the on times T_{ON} of the drive control signals V_{DRIVE1} , V_{DRIVE2} for controlling the FETs Q210, Q212 of the forward converter 140 to respectively increase and decrease the intensity of the LED light source. Due to hardware limitations, the controller may be operable to adjust the on times T_{ON} of the drive control signals V_{DRIVE1} , V_{DRIVE2} by a minimum time step T_{STEP} , which results in a corresponding step I_{STEP} in the load current I_{LOAD} . Near the high-end intensity I_{HE} , this step I_{STEP} in the load current I_{LOAD} may be rather large (e.g., approximately 70 mA). Since it is desirable to adjust the load current I_{LOAD} by smaller amounts, the controller is operable to “dither” the on times T_{ON} of the drive control signals V_{DRIVE1} , V_{DRIVE2} , e.g., change the on times between two values that result in the magnitude of the load current being controlled to DC currents on either side of the target current I_{TRGT} .

FIG. 9 shows an example waveform of a load current conducted through an LED light source (e.g., the load current I_{LOAD}). For example, the load current I_{LOAD} shown in FIG. 9 may be conducted through the LED light source when the target current I_{TRGT} is at a steady-state value of approximately 390 mA. A controller (e.g., the controller 150 of the LED driver 100 shown in FIG. 1 and/or the controller controlling the forward converter 240 and the current sense circuit 260 shown in FIG. 2) may control a forward converter (e.g., the forward converter 140, 240) to conduct the load current I_{LOAD} shown in FIG. 9 through the LED light source. The controller adjusts the on times T_{ON} of the drive control signals V_{DRIVE1} , V_{DRIVE2} to control the magnitude of the load current I_{LOAD} to between two DC currents I_{L-1} , I_{L-2} that are separated by the step I_{STEP} (e.g., approximately 350 mA and 420 mA, respectively). The load current I_{LOAD} is characterized by a dithering frequency f_{DITHER} (e.g., approximately 2 kHz) and a dithering period T_{DITHER} as shown in FIG. 9. For example, a duty cycle DC_{DITHER} of the load current I_{LOAD} may be approximately 57%, such that the average magnitude of the load current I_{LOAD} is approximately equal to the target current I_{TRGT} (e.g., 390 mA for the example of FIG. 9).

FIG. 10 shows an example waveform of the load current I_{LOAD} when the target current I_{TRGT} is being increased with respect to time. As shown in FIG. 10, the controller 150 is able to adjust the on times T_{ON} of the drive control signals V_{DRIVE1} , V_{DRIVE2} to control the magnitude of the load current I_{LOAD} to between two DC currents I_{L-1} , I_{L-2} that are separated by the step I_{STEP} . The duty cycle DC_{DITHER} of the load current I_{LOAD} increases as the target current I_{TRGT} increases. At some point, the controller is able to control the on times T_{ON} of the drive control signals V_{DRIVE1} , V_{DRIVE2}

to achieve the desired target current I_{TRGT} without dithering the on times, thus resulting in a constant section 400 of the load current I_{LOAD} . As the target current I_{TRGT} continues to increase after the constant section 400, the controller is able to control the on times T_{ON} of the drive control signals V_{DRIVE1} , V_{DRIVE2} to dither the magnitude of the load current I_{LOAD} between the DC current I_{L-2} and a larger DC current I_{L-3} .

However, the constant section 400 of the load current I_{LOAD} as shown in FIG. 10 may cause the human eye to detect a visible step in the adjustment of the intensity of the LED light source. Therefore, when the controller is actively adjusting the intensity of the LED light source, the controller is operable to add a periodic supplemental signal (e.g., a ramp signal I_{RAMP} or sawtooth waveform) to the target current I_{TRGT} . FIG. 11 shows example waveforms of the ramp signal I_{RAMP} and the resulting load current I_{LOAD} when the ramp signal is added to the target current I_{TRGT} . Note that these waveforms are not to scale and the ramp signal I_{RAMP} is a digital waveform. The ramp signal I_{RAMP} is characterized by a ramp frequency f_{RAMP} (e.g., approximately 238 Hz) and a ramp period T_{RAMP} . The ramp signal I_{RAMP} may have, for example, a maximum ramp signal magnitude $I_{RAMP-MAX}$ of approximately 150 mA. The ramp signal I_{RAMP} and may increase with respect to time in, for example, approximately 35 steps across the length of the ramp period T_{RAMP} . When the controller adds the ramp signal I_{RAMP} to the target current I_{TRGT} to control the on times T_{ON} of the drive control signals V_{DRIVE1} , V_{DRIVE2} , the resulting load current I_{LOAD} has a varying magnitude as shown in FIG. 11. As a result, the perception to the human eye of the visible steps in the intensity of the LED light source as the controller is actively adjusting the intensity of the LED light source is reduced.

When the target current I_{TRGT} returns to a steady-state value, the controller may stop adding the ramp signal I_{RAMP} to the target current I_{TRGT} . For example, the controller may decrease the magnitude of the ramp signal I_{RAMP} from the maximum ramp signal magnitude $I_{RAMP-MAX}$ to zero across a period of time after the target current I_{TRGT} has reached a steady-state value.

While FIG. 11 shows the ramp signal I_{RAMP} (i.e., a sawtooth waveform) that is added to the target current I_{TRGT} , other periodic waveforms could be used.

Although the present invention has been described in relation to particular embodiments thereof, many other variations and modifications and other uses will become apparent to those skilled in the art. It is preferred, therefore, that the present invention be limited not by the specific disclosure herein, but only by the appended claims.

What is claimed is:

1. A load control device for controlling the amount of power delivered to an electrical load, the load control device comprising:

an isolated forward converter operable to receive a bus voltage and to conduct a load current through the electrical load, the forward converter comprising a transformer that comprises a primary winding coupled in series with a first semiconductor switch and a secondary winding adapted to be operatively coupled to the electrical load, the forward converter further comprising a half-bridge inverter comprising the first semiconductor switch and a second semiconductor switch coupled in series across the bus voltage for generating an inverter voltage at a junction of the two semiconductor switches, the junction of the two semiconductor switches coupled to the primary winding of the trans-

13

former through a capacitor, such that a primary voltage across the primary winding has a positive polarity when the first semiconductor switch is conductive and has a negative polarity when the second semiconductor switch is conductive, the transformer operable to transfer power to the secondary winding when either of the semiconductor switches is conductive, the forward converter further comprising a sense resistor coupled in series with the primary winding for producing a sense voltage representative of a primary current conducted through the primary winding;

a controller coupled to the forward converter for controlling the first semiconductor switch to control the load current conducted through the electrical load; and

a current sense circuit operable to receive the sense voltage, the current sense circuit comprising an averaging circuit for averaging the sense voltage when the first semiconductor switch of the forward converter is conductive, so as to generate a load current control signal that is representative of a real component of the primary current.

2. The load control device of claim 1, wherein the current sense circuit comprises a third semiconductor switch for disconnecting the sense voltage from the averaging circuit, the controller operable to render the third semiconductor switch conductive and non-conductive, such that the sense voltage is coupled to the averaging circuit when the first semiconductor switch of the forward converter is conductive.

3. The load control device of claim 2, wherein the controller renders the first semiconductor switch conductive for an on time, and controls the third semiconductor switch, such that the sense voltage is coupled to the averaging circuit for the on time.

4. The load control device of claim 2, wherein the controller renders the first semiconductor switch conductive for an on time, and controls the third semiconductor switch such that the sense voltage is coupled to the averaging circuit for the on time plus an additional amount of time when a target amount of power to be delivered to the electrical load is [greater] *less* than a threshold amount.

5. The load control device of claim 2, wherein the sense voltage is coupled to the averaging circuit through two series-connected resistors, the third semiconductor switch coupled between the junction of the two resistors and circuit common, such that the sense voltage is coupled to the averaging circuit when the third semiconductor switch is non-conductive.

6. The load control device of claim 1, wherein the controller is operable to control the magnitude of the load current to control the amount of power delivered to the electrical load to a target amount of power.

7. A load control device for controlling the amount of power delivered to an electrical load, the load control device comprising:

an isolated forward converter operable to receive a bus voltage and to conduct a load current through the electrical load, the forward converter comprising a transformer that comprises a primary winding coupled in series with a first semiconductor switch and a secondary winding adapted to be operatively coupled to the electrical load, the forward converter further comprising a sense resistor coupled in series with the primary winding for producing a sense voltage representative of a primary current conducted through the primary winding;

14

a controller coupled to the forward converter for controlling the first semiconductor switch to control the magnitude of the load current conducted through the electrical load to control the amount of power delivered to the electrical load to a target amount of power; and

a current sense circuit operable to receive the sense voltage and to average the sense voltage when the first semiconductor switch of the forward converter is conductive, so as to generate a load current control signal that is representative of a real component of the primary current;

wherein the current sense circuit is operable to average the sense voltage for an on time when the first semiconductor switch of the forward converter is conductive plus an [addition] *additional* amount of time, so as to generate the load current control signal that is representative of the real component of the primary current.

8. The load control device of claim 7, wherein the current sense circuit comprises an averaging circuit for averaging the sense voltage when the first semiconductor switch of the forward converter is conductive, such that the load current control signal is representative of the real component of the primary current, and wherein the averaging circuit comprises a capacitor across which the load current control signal is generated.

9. The load control device of claim 8, wherein the current sense circuit comprises an averaging circuit for averaging the sense voltage when the first semiconductor switch of the forward converter is conductive, such that the load current control signal is representative of the real component of the primary current.

10. The load control device of claim 9, wherein the forward converter comprises a half-bridge inverter comprising the first semiconductor switch and a second semiconductor switch coupled in series across the bus voltage for generating an inverter voltage at a junction of the two semiconductor switches, the junction of the two semiconductor switches coupled to the primary winding of the transformer through a capacitor, such that a primary voltage across the primary winding has a positive polarity when the first semiconductor switch is conductive and has a negative polarity when the second semiconductor switch is conductive, the transformer operable to transfer power to a secondary winding when either of the semiconductor switches is conductive.

11. The load control device of claim 8, wherein the current sense circuit is operable to average the sense voltage for the on time plus the [addition] *additional* amount of time when the target amount of power is [greater] *less* than a threshold amount.

12. The load control device of claim 11, wherein the [addition] *additional* amount of time is a function of the target amount of power.

13. The load control device of claim 12, wherein the [addition] *additional* amount of time increases as the target amount of power decreases.

14. The load control device of claim 13, wherein the [addition] *additional* amount of time increases linearly as the target amount of power decreases.

15. An LED driver for controlling the intensity of an LED light source, the LED driver comprising:

an isolated forward converter operable to receive a bus voltage and to conduct a load current through the LED light source, the forward converter comprising a transformer that comprises a primary winding and a secondary winding adapted to be operatively coupled to

15

the LED light source, the forward converter further comprising a half-bridge inverter circuit for generating an inverter voltage that is coupled to the primary winding of the transformer through a capacitor for producing a primary voltage across the primary winding, the forward converter further comprising a sense resistor coupled in series with the primary winding for producing a sense voltage representative of a primary current conducted through the primary winding;

a controller coupled to the forward converter for controlling the half-bridge inverter circuit to control the load current conducted through the LED light source to control the intensity of the LED light source to a target intensity; and

a current sense circuit operable to receive the sense voltage and to average the sense voltage when the magnitude of the primary voltage across the primary winding is positive and greater than approximately zero volts, so as to generate a load current control signal that is representative of a real component of the primary current.

16. The LED driver of claim **15**, wherein the half-bridge inverter circuit comprises first and second semiconductor switches coupled in series across the bus voltage for generating the inverter voltage at a junction of the two semiconductor switches, the junction of the two semiconductor switches coupled to the primary winding of the transformer through the capacitor, the controller coupled to the forward converter for controlling the first and second semiconductor switches, such that the primary voltage across the primary winding has a positive polarity when the first semiconductor switch is conductive and has a negative polarity when the second semiconductor switch is conductive, the transformer operable to transfer power to the secondary winding when either of the semiconductor switches is conductive.

17. The LED driver of claim **16**, wherein the current sense circuit comprises an averaging circuit for averaging the sense voltage when the first semiconductor switch of the half-bridge inverter circuit is conductive, such that the load current control signal is representative of the real component of the primary current.

18. The LED driver of claim **17**, wherein the current sense circuit comprises a third semiconductor switch for disconnecting the sense voltage from the averaging circuit, the controller operable to render the third semiconductor switch conductive and non-conductive, such that the sense voltage is coupled to the averaging circuit when the first semiconductor switch of the half-bridge inverter circuit is conductive.

19. The LED driver of claim **18**, wherein the controller renders the first semiconductor switch conductive for an on time, and controls the third semiconductor switch such that the sense voltage is coupled to the averaging circuit for the on time plus an offset time when the target intensity is [greater] *less* than a threshold intensity.

20. The LED driver of claim **19**, wherein the offset time is a function of the target intensity.

21. The LED driver of claim **20**, wherein the offset time increases as the target intensity decreases.

22. The LED driver of claim **21**, wherein the offset time increases linearly as the target intensity decreases.

23. The LED driver of claim **18**, wherein the controller renders the first semiconductor switch conductive for an on time, and controls the third semiconductor switch, such that the sense voltage is coupled to the averaging circuit for the on time.

16

24. The LED driver of claim **16**, wherein the forward converter comprises an energy-storage inductor operatively coupled in series with the secondary winding of the transformer, the energy-storage inductor comprising a partially-gapped magnetic core set.

25. A forward converter for controlling the amount of power delivered to an electrical load from an input voltage, the forward converter comprising:

a transformer comprising a primary winding and a secondary winding adapted to be operatively coupled to the electrical load;

a half-bridge inverter circuit comprising first and second semiconductor switches coupled in series across the input voltage for generating an inverter voltage at a junction of the two semiconductor switches;

a capacitor coupled between the junction of the two semiconductor switches of the half-bridge inverter circuit and the primary winding of the transformer, such that a primary voltage is produced across the primary winding, the transformer operable to transfer power to the secondary winding when either of the semiconductor switches is conductive;

a controller coupled to the half-bridge inverter circuit for controlling the first and second semiconductor switches to control a load current conducted through the electrical load;

a sense resistor coupled in series with the primary winding for producing a sense voltage representative of a primary current conducted through the primary winding; and

a current sense circuit operable to receive the sense voltage and to average the sense voltage when the first semiconductor switch of the half-bridge inverter circuit is conductive, so as to generate a load current control signal that is representative of a real component of the primary current.

26. The forward converter of claim **25**, wherein the current sense circuit comprises an averaging circuit for averaging the sense voltage when the first semiconductor switch of the half-bridge inverter circuit is conductive, such that the load current control signal is representative of the real component of the primary current.

27. The forward converter of claim **26**, wherein the current sense circuit comprises a third semiconductor switch for disconnecting the sense voltage from the averaging circuit, the controller operable to render the third semiconductor switch conductive and non-conductive, such that the sense voltage is coupled to the averaging circuit when the first semiconductor switch of the half-bridge inverter circuit is conductive.

28. The forward converter of claim **27**, wherein the controller renders the first semiconductor switch conductive for an on time, and controls the third semiconductor switch, such that the sense voltage is coupled to the averaging circuit for the on time.

29. The forward converter of claim **27**, wherein the controller renders the first semiconductor switch conductive for an on time, and controls the third semiconductor switch such that the sense voltage is coupled to the averaging circuit for the on time plus an offset time when a target amount of power to be delivered to the electrical load is [greater] *less* than a threshold amount.