

US00RE46499E

(19) **United States**
(12) **Reissued Patent**
Face et al.

(10) **Patent Number: US RE46,499 E**
(45) **Date of Reissued Patent: Aug. 1, 2017**

(54) **SELF-POWERED SWITCH INITIATION SYSTEM**

USPC 341/34, 176; 307/116, 119
See application file for complete search history.

(75) Inventors: **Bradbury R. Face**, Smithfield, VA (US); **Clark D. Boyd**, Portsmouth, VA (US); **Glenn F. Rogers, Jr.**, Hampton, VA (US); **Gregory P. Thomas**, Davidson, NC (US)

(56) **References Cited**

(73) Assignee: **Face International Corporation**, Norfolk, VA (US)

U.S. PATENT DOCUMENTS

(21) Appl. No.: **12/399,954**

447,921 A	3/1891	Tesla
1,872,257 A	8/1932	Durkee
2,565,158 A	8/1951	Williams
2,813,242 A	11/1957	Crumpp
2,874,292 A	2/1959	Varley
2,995,633 A	8/1961	Puharich et al.
3,077,574 A	2/1963	Marks
3,093,760 A	6/1963	Tarasevich
3,219,850 A	11/1965	Langevin
3,230,455 A	1/1966	Kosta, Jr.
3,270,283 A	8/1966	Ikrath et al.
3,315,166 A	4/1967	Crump

(22) Filed: **Mar. 8, 2009**

Related U.S. Patent Documents

Reissue of:

(64) Patent No.: **7,084,529**
Issued: **Aug. 1, 2006**
Appl. No.: **10/188,633**
Filed: **Jul. 3, 2002**

FOREIGN PATENT DOCUMENTS

U.S. Applications:

DE	24 21 705	11/1975
DE	3231117	2/1984

(63) Continuation of application No. 12/183,574, filed on Jul. 31, 2008, now abandoned, which is an application for the reissue of Pat. No. 7,084,529.

(Continued)

(60) Provisional application No. 60/302,990, filed on Jul. 3, 2001.

Primary Examiner — Colin LaRose

(51) **Int. Cl.**
H03K 17/96 (2006.01)

(74) *Attorney, Agent, or Firm* — Daniel A. Tanner, III

(52) **U.S. Cl.**
CPC **H03K 17/964** (2013.01); **H01H 2239/076** (2013.01); **H01H 2300/03** (2013.01); **H03K 2217/94089** (2013.01); **Y02B 90/224** (2013.01); **Y04S 20/14** (2013.01); **Y10T 307/766** (2015.04)

(57) **ABSTRACT**

A self-powered switching device using a prestressed flex-tensional electroactive member generates a signal for activation of a latching relay. The electroactive member has a piezoelectric element with a convex and a concave face that may be compressed to generate an electrical pulse. The flex-tensional electroactive member and associated signal generation circuitry can be hardwired directly to the latching relay or may be coupled to a transmitter for sending an RF signal to a receiver which actuates the latching relay.

(58) **Field of Classification Search**
CPC H03K 17/964; H03K 2217/94089; Y10T 307/766; Y04S 20/14; Y02B 90/224; H01H 2300/03; H01H 2239/076

49 Claims, 9 Drawing Sheets

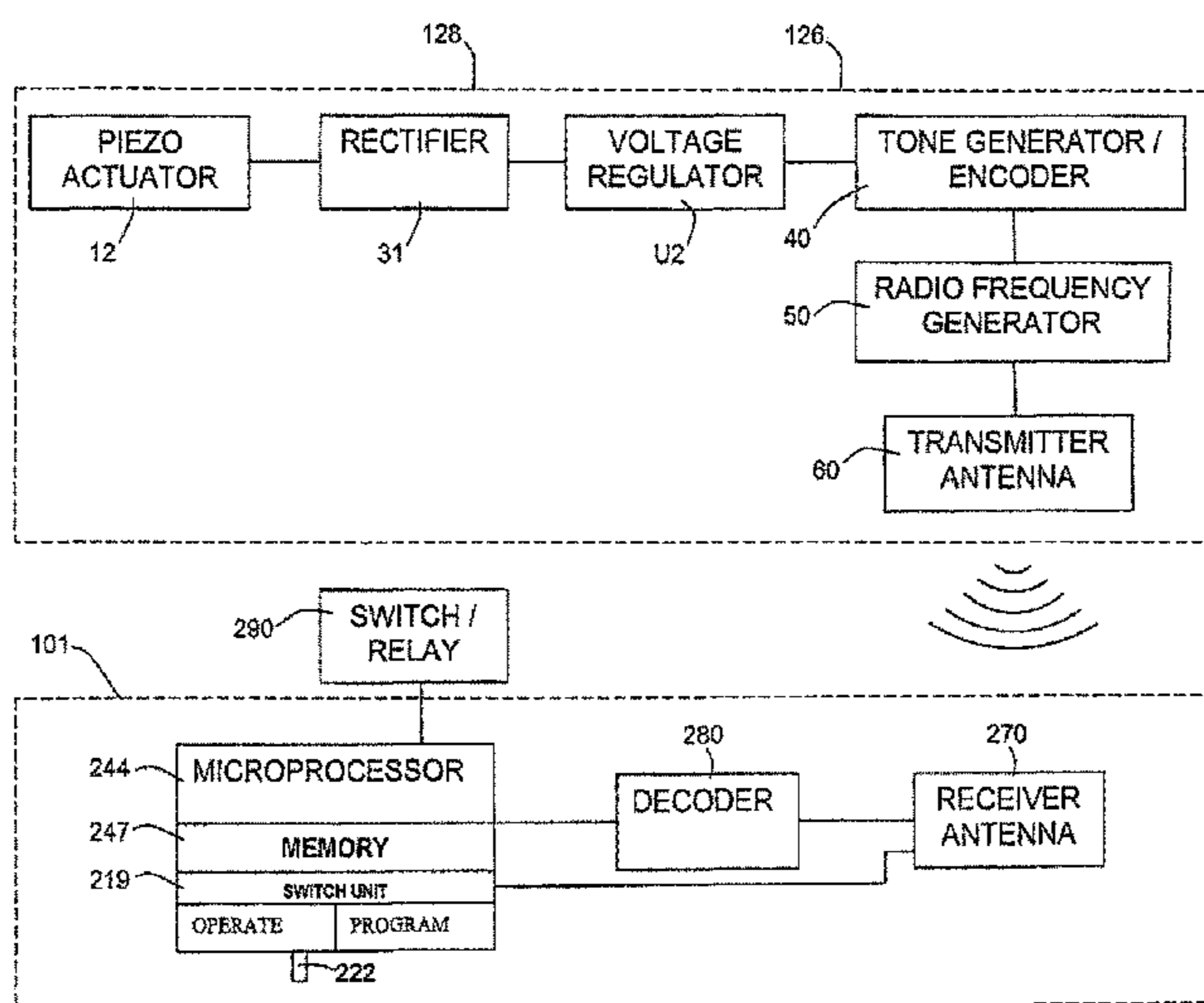

US RE46,499 E

(56)	References Cited		
	U.S. PATENT DOCUMENTS		
	3,370,567 A	2/1968	Rieth
	3,456,134 A	7/1969	Ko
	3,553,588 A	1/1971	Honig
	3,596,262 A	7/1971	Rollwitz et al.
	3,614,760 A	10/1971	Zimmet
	3,621,398 A	11/1971	Willis
	3,624,451 A	11/1971	Gauld
	3,633,106 A	1/1972	Willis
	3,683,211 A	8/1972	Perlman et al.
	3,697,975 A	10/1972	Bernstein et al.
	3,735,412 A	5/1973	Kampmeyer
	3,781,836 A	12/1973	Kruper et al.
	3,781,955 A	1/1974	Lavrinenko et al.
	3,796,958 A	3/1974	Johnston et al.
	3,818,467 A	6/1974	Willis
	3,824,857 A	7/1974	Smith
	3,827,038 A	7/1974	Willis
	3,866,206 A	2/1975	DeGiorgio et al.
	3,928,760 A	12/1975	Isoda
	3,943,936 A	3/1976	Rasor et al.
	3,949,247 A	4/1976	Fenner et al.
	3,970,939 A	7/1976	Willis
	3,971,028 A	7/1976	Funk
	3,986,119 A	10/1976	Hemmer, Jr. et al.
	4,001,798 A	1/1977	Robinson
	4,078,160 A	3/1978	Bost
	4,110,630 A	8/1978	Hendel
	4,127,800 A	11/1978	Long et al.
	4,160,234 A	7/1979	Karbo et al.
	4,163,208 A	7/1979	Merz
	4,177,438 A	12/1979	Vittoria
	4,177,800 A	12/1979	Enger
	4,220,907 A	9/1980	Pappas et al.
	4,231,260 A	11/1980	Chamuel
	4,237,728 A	12/1980	Betts et al.
	4,257,010 A *	3/1981	Bergman et al. 331/65
	4,259,715 A	3/1981	Morokawa
	4,300,119 A	11/1981	Wiernicki
	4,349,762 A	9/1982	Kitamura et al.
	4,355,309 A	10/1982	Hughey et al.
	4,371,814 A	2/1983	Hannas et al.
	4,402,524 A	9/1983	D'Antonio et al.
	4,412,355 A	10/1983	Terbrack
	4,433,719 A	2/1984	Cherry et al.
	4,450,375 A *	5/1984	Siegal B41J 2/04 137/831
	4,471,353 A	9/1984	Cernik
	4,489,269 A	12/1984	Edling et al.
	4,504,761 A	3/1985	Triplett
	4,510,484 A	4/1985	Snyder
	4,521,712 A *	6/1985	Braun et al. 310/339
	4,524,283 A	6/1985	Latvus
	4,538,139 A	8/1985	Clemente
	4,595,864 A	6/1986	Stiefelmeyer et al.
	4,612,472 A	9/1986	Kakizaki et al.
	4,626,698 A	12/1986	Harnden, Jr. et al.
	4,701,681 A	10/1987	Koike
	4,704,543 A	11/1987	Barker et al.
	4,739,211 A	4/1988	Strachan
	4,748,366 A	5/1988	Taylor
	4,770,438 A	9/1988	Sugasawa et al.
	4,786,837 A	11/1988	Kalnin et al.
	4,870,700 A	9/1989	Ormanns et al.
	4,878,052 A	10/1989	Schulze
	5,012,223 A	4/1991	Griebell et al.
	5,136,202 A	8/1992	Carenzo et al.
	5,146,153 A	9/1992	Luchaco et al.
	5,151,695 A	9/1992	Rollwitz et al.
	5,237,264 A	8/1993	Moselev et al.
	5,239,205 A *	8/1993	Hoffman H01H 23/00 200/277.2
	5,262,696 A	11/1993	Culp
	5,270,704 A	12/1993	Sosa Quintana et al.
	5,278,471 A	1/1994	Uehara et al.
	5,289,160 A	2/1994	Fiorletta
	5,291,193 A *	3/1994	Isobe G08B 25/10 340/12.3
	5,301,362 A	4/1994	Ohkawa
	5,317,303 A	5/1994	Ross et al.
	5,327,041 A	7/1994	Culp
	5,340,954 A	8/1994	Hoffman
	5,419,176 A	5/1995	Walker
	5,431,694 A	7/1995	Snaper et al.
	5,471,721 A	12/1995	Haertling
	5,491,486 A	2/1996	Welles, II et al.
	5,499,013 A	3/1996	Konotchick
	5,535,627 A	7/1996	Swanson et al.
	5,546,070 A	8/1996	Ellmann et al.
	5,548,189 A	8/1996	Williams
	5,563,600 A	10/1996	Miyake
	5,569,854 A	10/1996	Ishida et al.
	5,572,190 A	11/1996	Ross et al.
	5,578,877 A	11/1996	Tiemann
	5,581,023 A	12/1996	Handfield
	5,581,454 A	12/1996	Collins
	5,589,725 A	12/1996	Haertling
	5,592,169 A	1/1997	Nakamura et al.
	5,605,336 A	2/1997	Gaoiran et al.
	5,632,841 A *	5/1997	Hellbaum B32B 37/144 156/160
	5,675,296 A	10/1997	Tomikawa
	5,717,258 A	2/1998	Park
	5,731,691 A	3/1998	Noto
	5,734,445 A	3/1998	Neill
	5,741,966 A	4/1998	Handfield
	5,749,547 A	5/1998	Young et al.
	5,751,092 A	5/1998	Abe
	5,781,104 A	7/1998	Huang
	5,797,201 A	8/1998	Huang
	5,801,475 A	9/1998	Kimura
	5,835,996 A	11/1998	Hashimoto et al.
	5,839,306 A	11/1998	Nunuparov
	5,844,516 A	12/1998	Viljanen
	5,854,994 A	12/1998	Canada et al.
	5,861,704 A	1/1999	Kitami et al.
	5,872,513 A	2/1999	Fitzgibbon et al.
	5,886,647 A	3/1999	Badger et al.
	5,886,847 A	3/1999	Lee et al.
	5,889,464 A	3/1999	Huang
	5,892,318 A	4/1999	Dai et al.
	5,898,384 A	4/1999	Alt et al.
	5,905,442 A	5/1999	Mosebrook et al.
	5,911,529 A	6/1999	Crisan
	5,923,542 A	7/1999	Sasaki et al.
	5,939,816 A	8/1999	Culp
	5,939,818 A	8/1999	Hakamata
	5,979,199 A	11/1999	Elpern
	5,982,355 A	11/1999	Jaeger et al.
	5,998,938 A	12/1999	Comberg et al.
	6,014,896 A	1/2000	Schoess
	6,025,783 A	2/2000	Steffens, Jr.
	6,026,165 A	2/2000	Marino et al.
	6,028,506 A	2/2000	Xiao
	RE36,703 E	5/2000	Heitschel et al.
	6,087,757 A	7/2000	Honbo et al.
	6,112,165 A	8/2000	Uhl et al.
	6,122,165 A	9/2000	Schmitt et al.
	6,174,073 B1 *	1/2001	Regan G08C 17/02 315/312
	6,175,302 B1	1/2001	Huang
	6,188,163 B1	2/2001	Danov
	6,243,007 B1	6/2001	McLaughlin
	6,252,336 B1	6/2001	Hall
	6,252,358 B1	6/2001	Xydis et al.
	6,256,296 B1	7/2001	Ruziak et al.
	6,259,372 B1	7/2001	Taranowski et al.
	6,304,176 B1 *	10/2001	Discenzo 340/539.26
	6,529,127 B2	3/2003	Townsend et al.
	6,570,386 B2	5/2003	Goldstein
	6,573,611 B1	6/2003	Sohn et al.
	6,630,894 B1 *	10/2003	Boyd et al. 341/22
	6,700,310 B2 *	3/2004	Maue et al. 310/339
	6,731,708 B1	5/2004	Watanabe
	6,756,930 B1	6/2004	Nunuparov et al.

US RE46,499 E

(56)

References Cited

U.S. PATENT DOCUMENTS

6,812,594	B2 *	11/2004	Face et al.	307/119
6,812,851	B1	11/2004	Dukach et al.	
6,861,785	B2 *	3/2005	Andre	H02N 2/18 310/317
6,882,128	B1	4/2005	Rahmel et al.	
6,980,150	B2 *	12/2005	Conway et al.	341/176
6,992,423	B2	1/2006	Mancosu et al.	
7,237,203	B1	6/2007	Kuenzner	
2001/0003163	A1	6/2001	Bunger et al.	
2002/0021216	A1	2/2002	Vossiek et al.	
2002/0070712	A1	6/2002	Arul	
2003/0094856	A1 *	5/2003	Face et al.	307/116
2003/0105403	A1	6/2003	Istvan et al.	
2003/0143963	A1	7/2003	Pistor et al.	
2004/0174073	A9 *	9/2004	Face et al.	307/116
2004/0242169	A1	12/2004	Albsmeier et al.	
2005/0030177	A1	2/2005	Albsmeier et al.	
2005/0035600	A1	2/2005	Albsmeier et al.	
2005/0067949	A1	3/2005	Natarajan	
2005/0087019	A1 *	4/2005	Face	73/649
2005/0253486	A1	11/2005	Schmidt	
2005/0253503	A1	11/2005	Stegamat et al.	
2006/0018376	A1	1/2006	Schmidt	
2006/0091984	A1	5/2006	Schmidt	
2006/0109654	A1	5/2006	Coushaine et al.	

FOREIGN PATENT DOCUMENTS

DE	4034100	4/1992
DE	4429029 A1	2/1996

DE	297 12 270	U1	7/1997
DE	196 20 880		11/1997
DE	4017670	A1	1/1998
DE	10025561.2		5/2000
DE	100 63 305	C1	12/2000
DE	199 55 722		5/2001
EP	0011991	A1	6/1980
EP	0673102	A1	9/1995
GB	2095053	A	9/1982
GB	2259172		3/1993
GB	2 350 245	A	11/2000
JP	57-174950		10/1982
JP	01-091598		4/1989
JP	05-175568		7/1993
JP	05-251785		9/1993
JP	09-322477		12/1997
JP	11-018162		1/1999
JP	2000-297567		2/2000
SU	506038		6/1973
WO	WO 95/29410		11/1995
WO	WO 96/15590		5/1996
WO	WO 96/28873		9/1996
WO	WO 97/36364		10/1997
WO	9811575	A1	3/1998
WO	9812873	A1	3/1998
WO	WO 98/36395		8/1998
WO	WO 00/02741		1/2000
WO	WO 01/45139	A2 *	6/2001
WO	WO 01/67580		9/2001
WO	WO 01/91315		11/2001
WO	WO 03/049148		6/2003

..... H02N 2/18

* cited by examiner

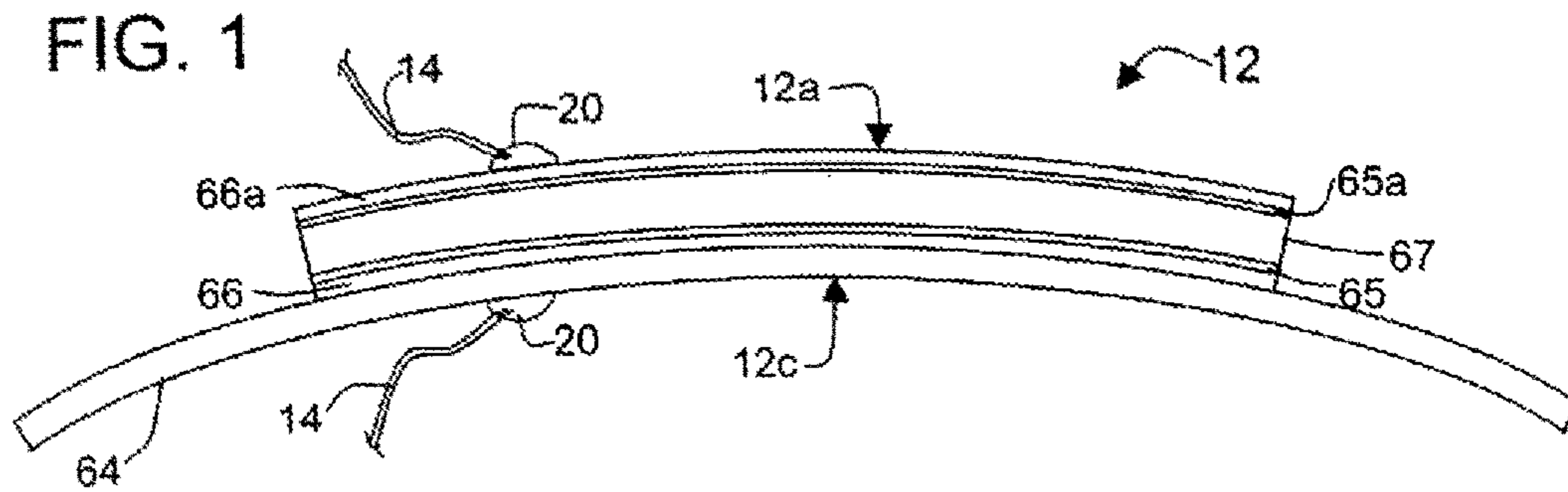

Related Art

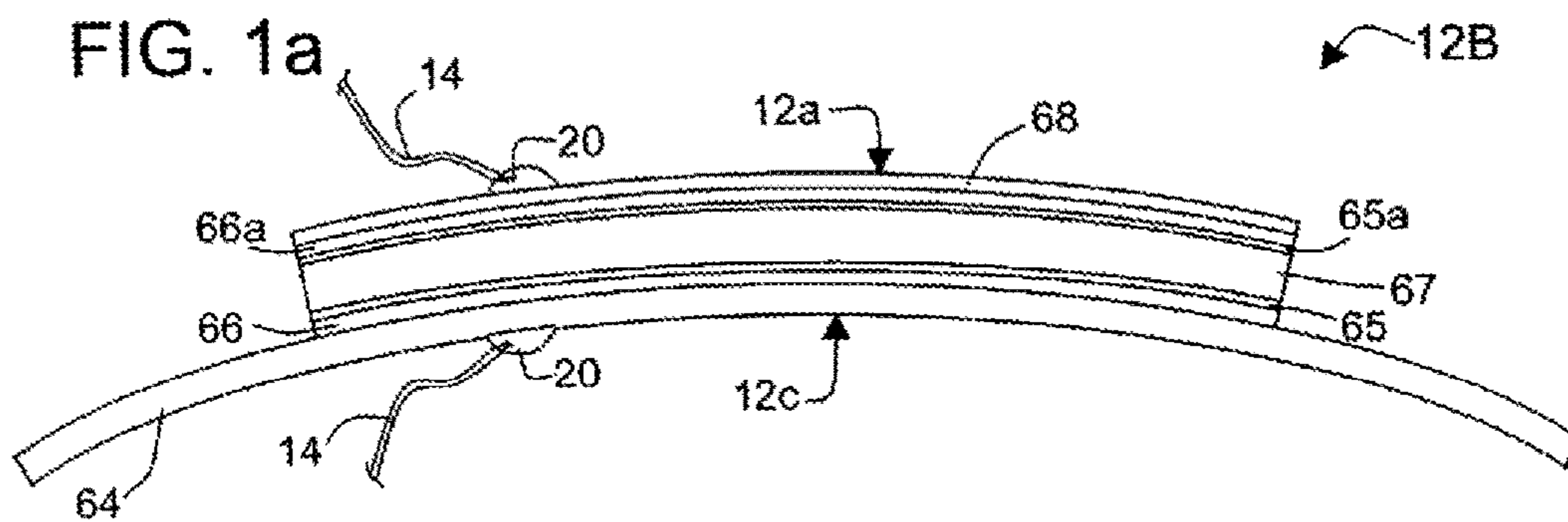

Related Art

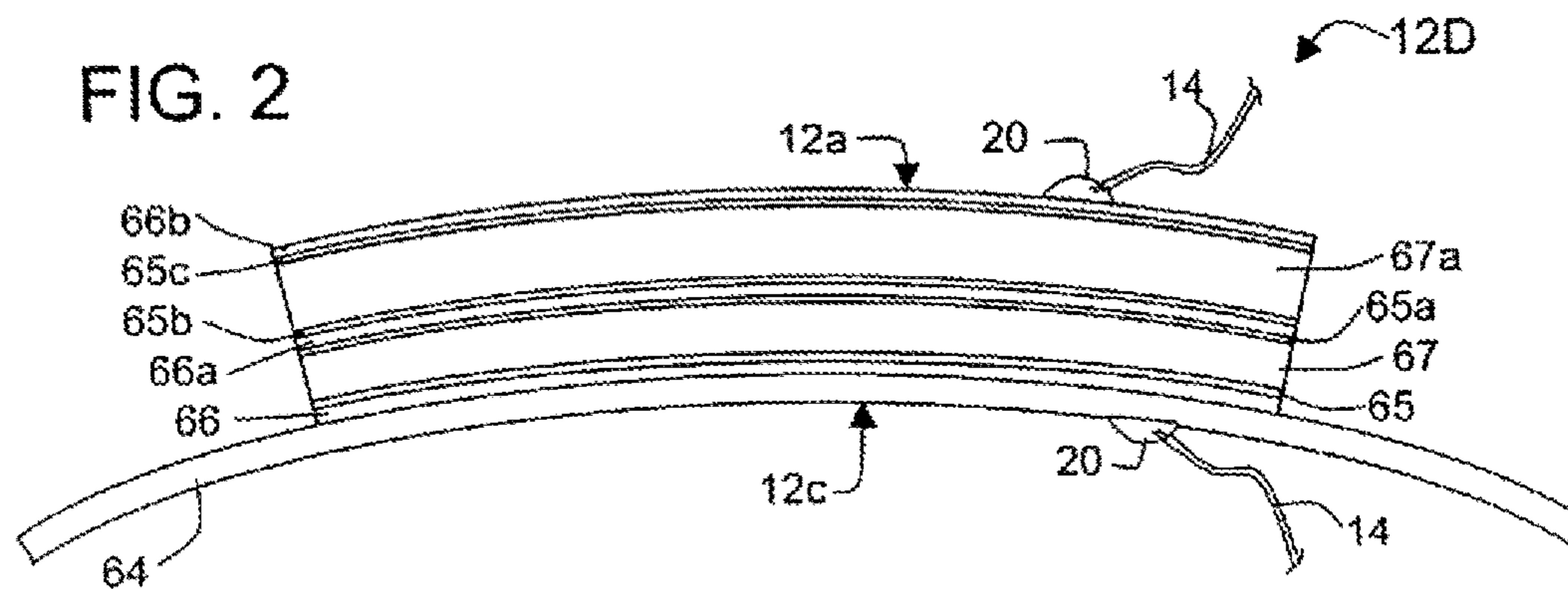

FIG. 3

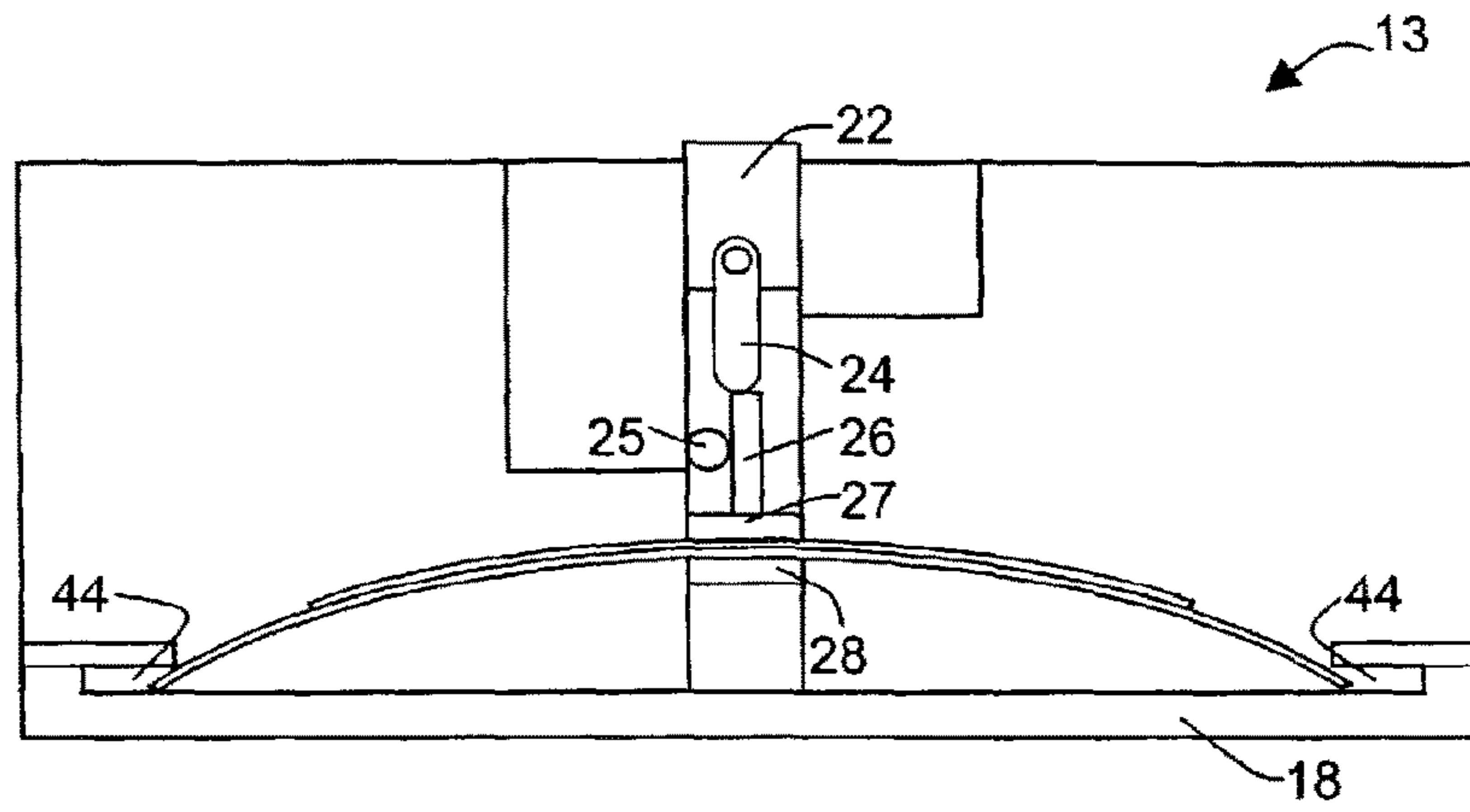

FIG. 4

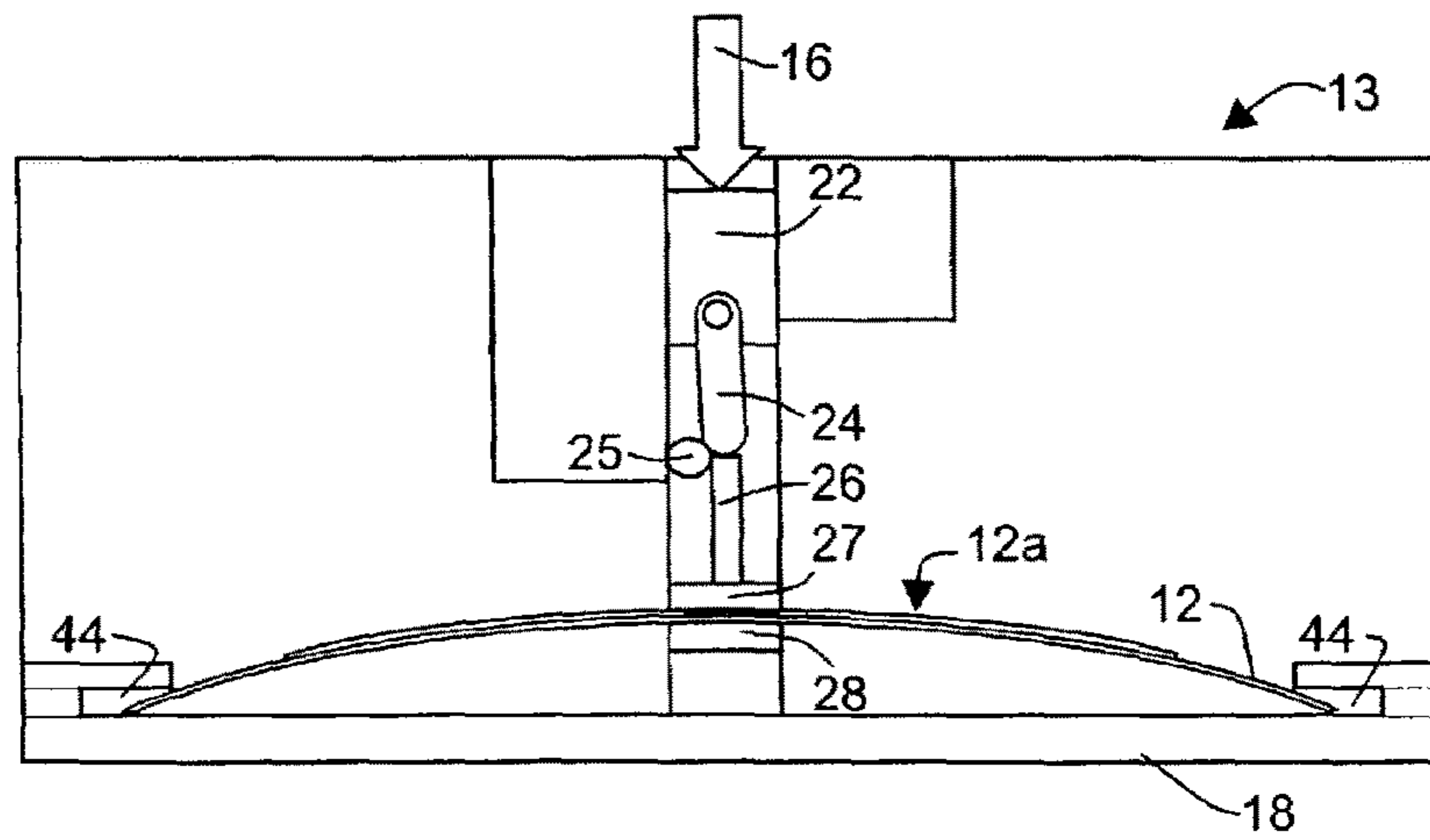

FIG. 5

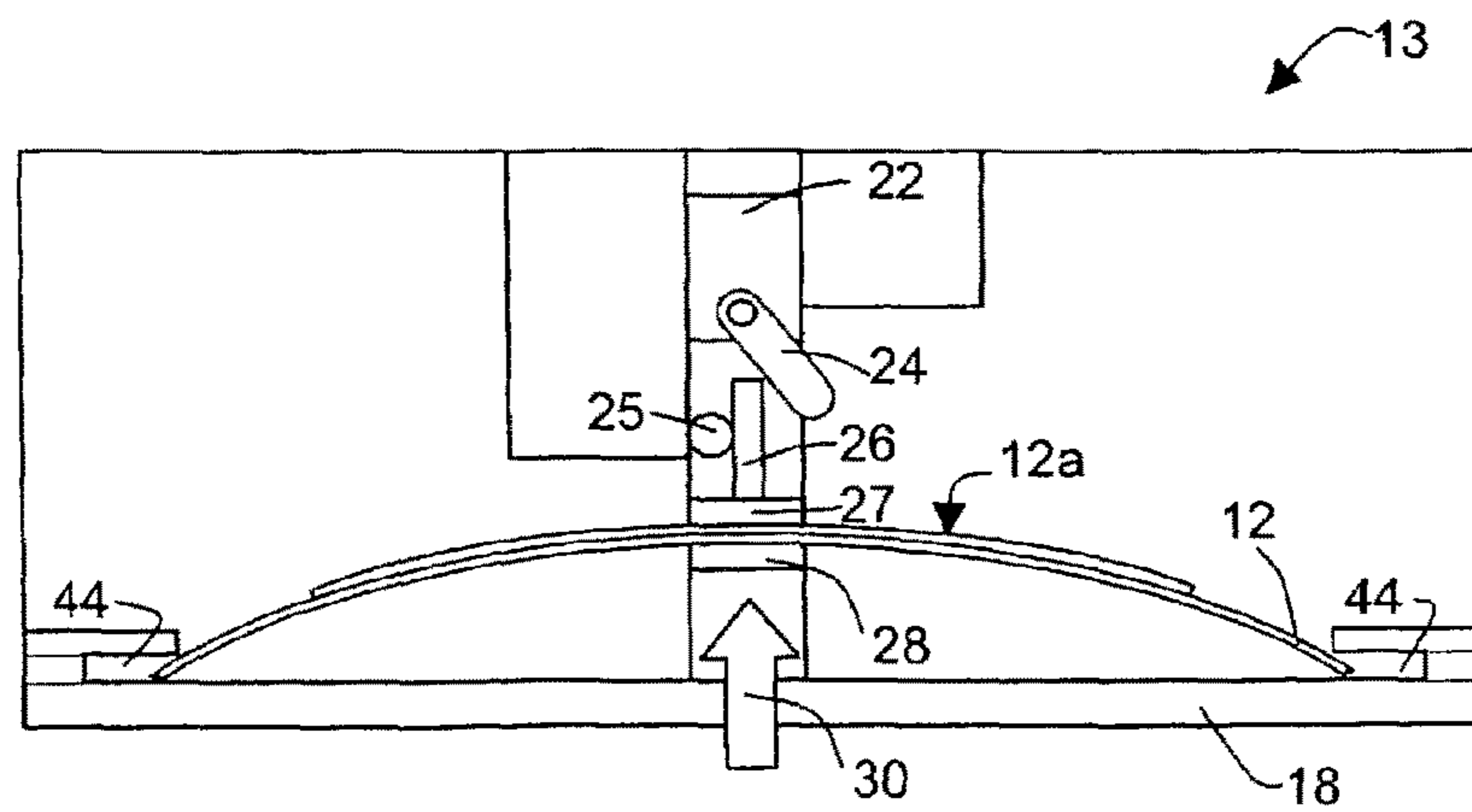

FIG. 6

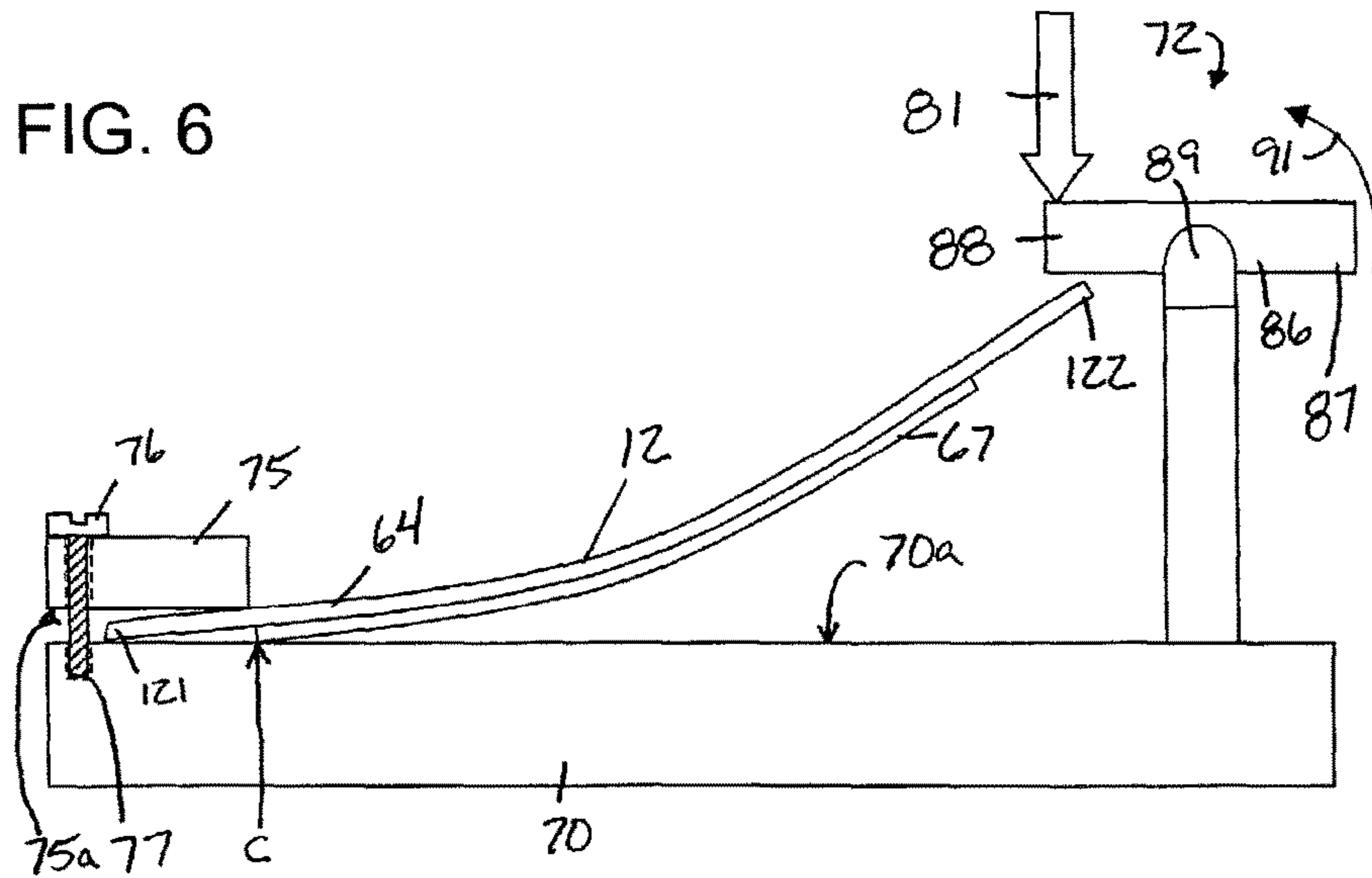
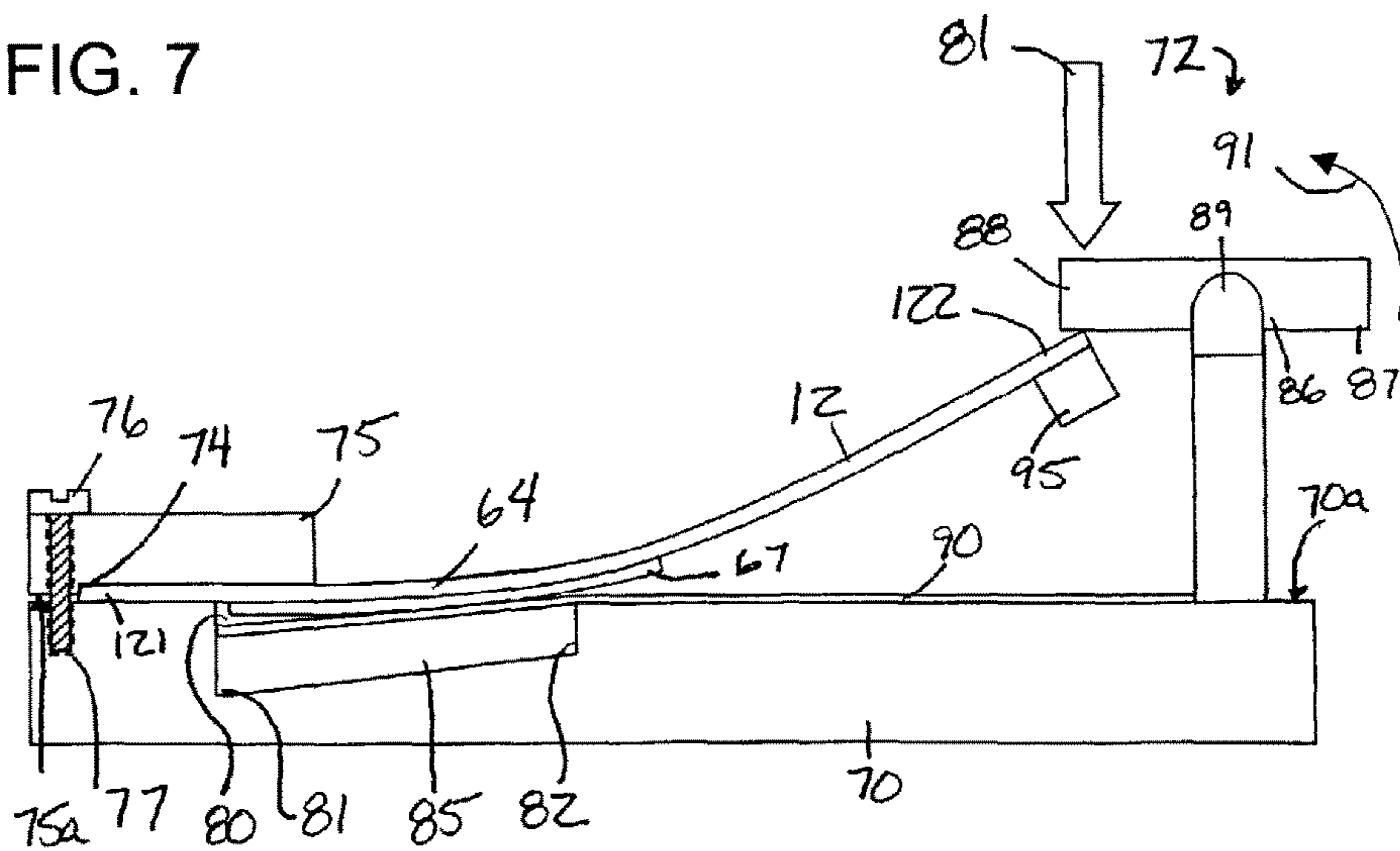

FIG. 7



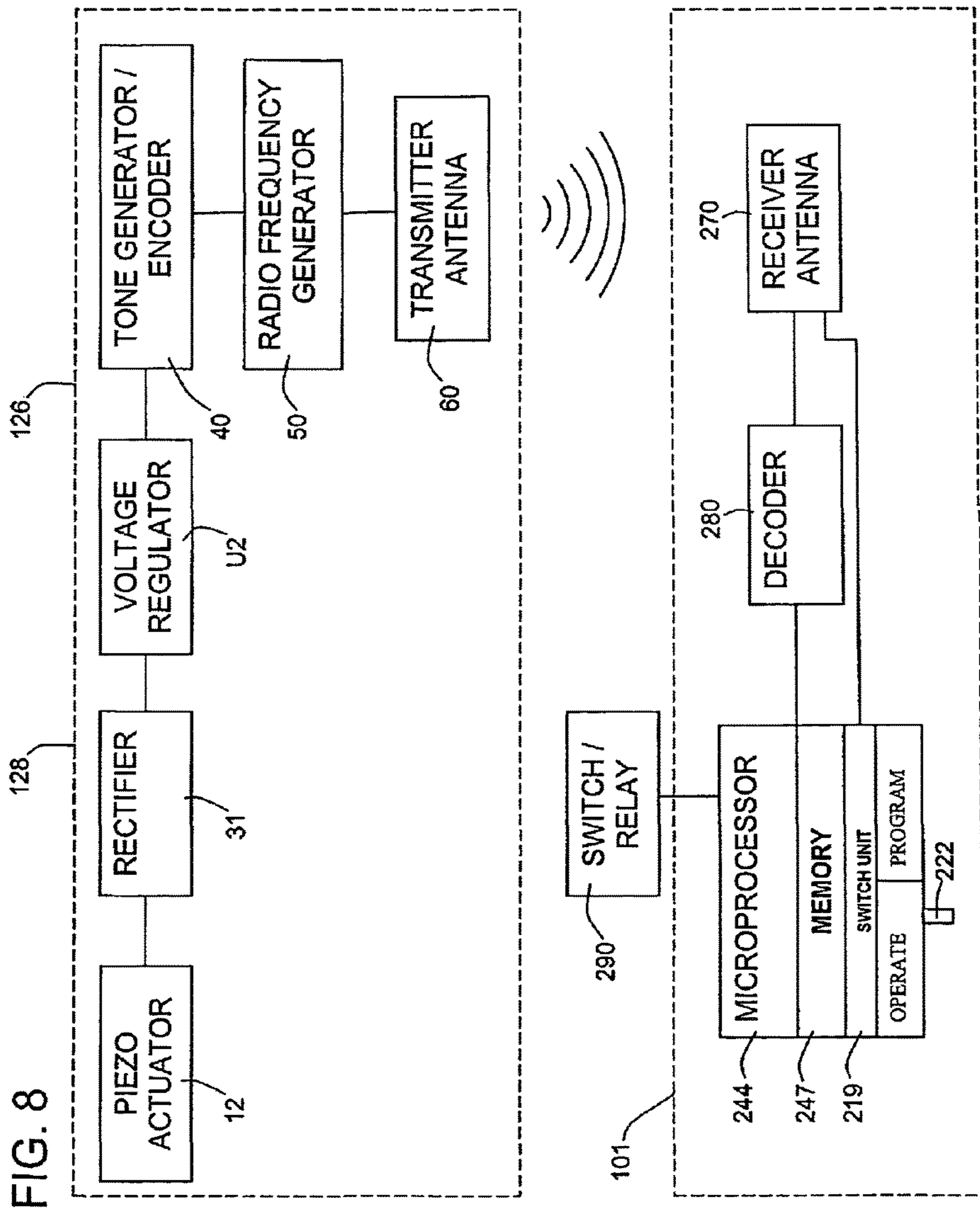
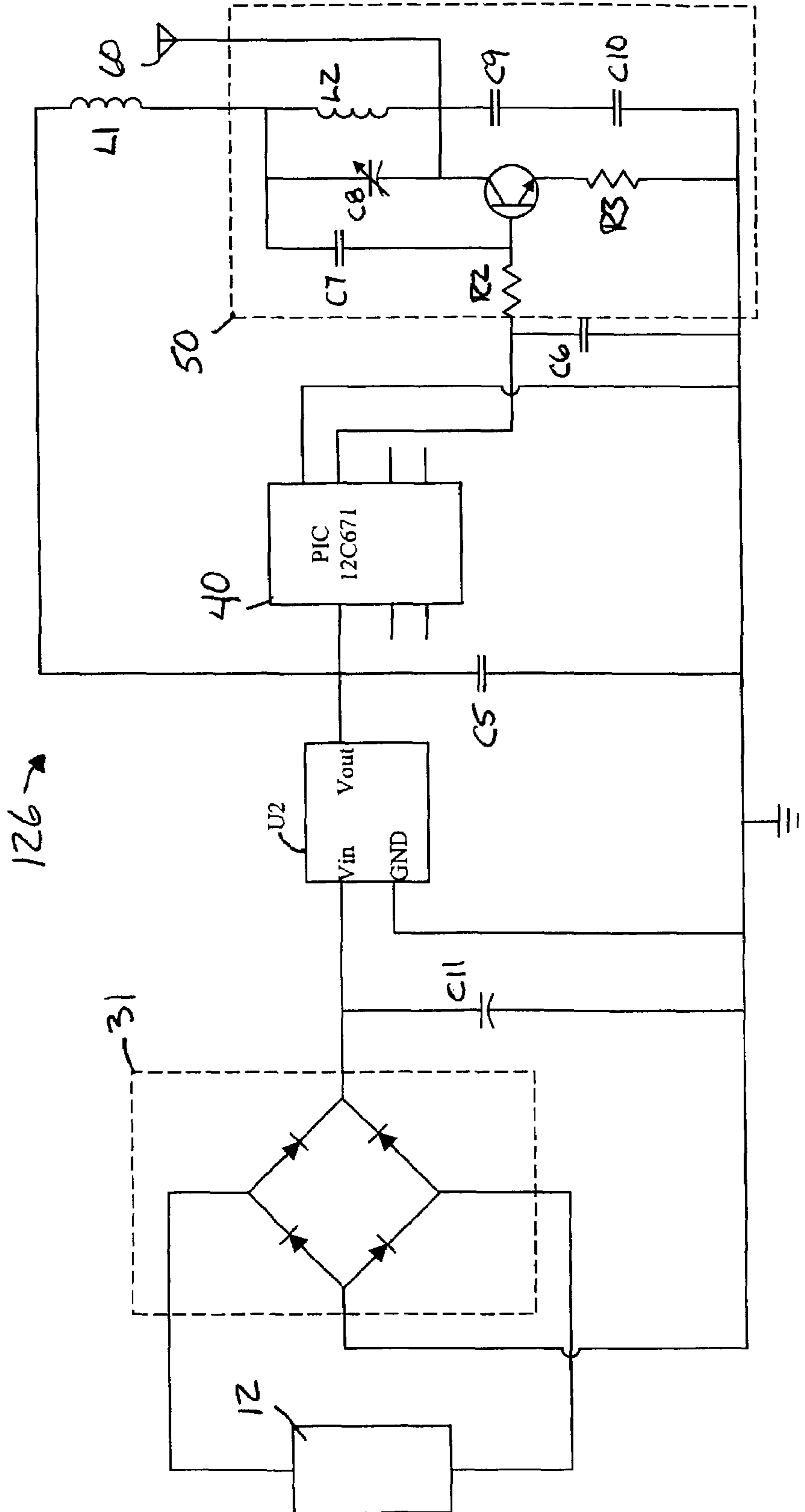

FIG. 9



126 →

FIG. 10a

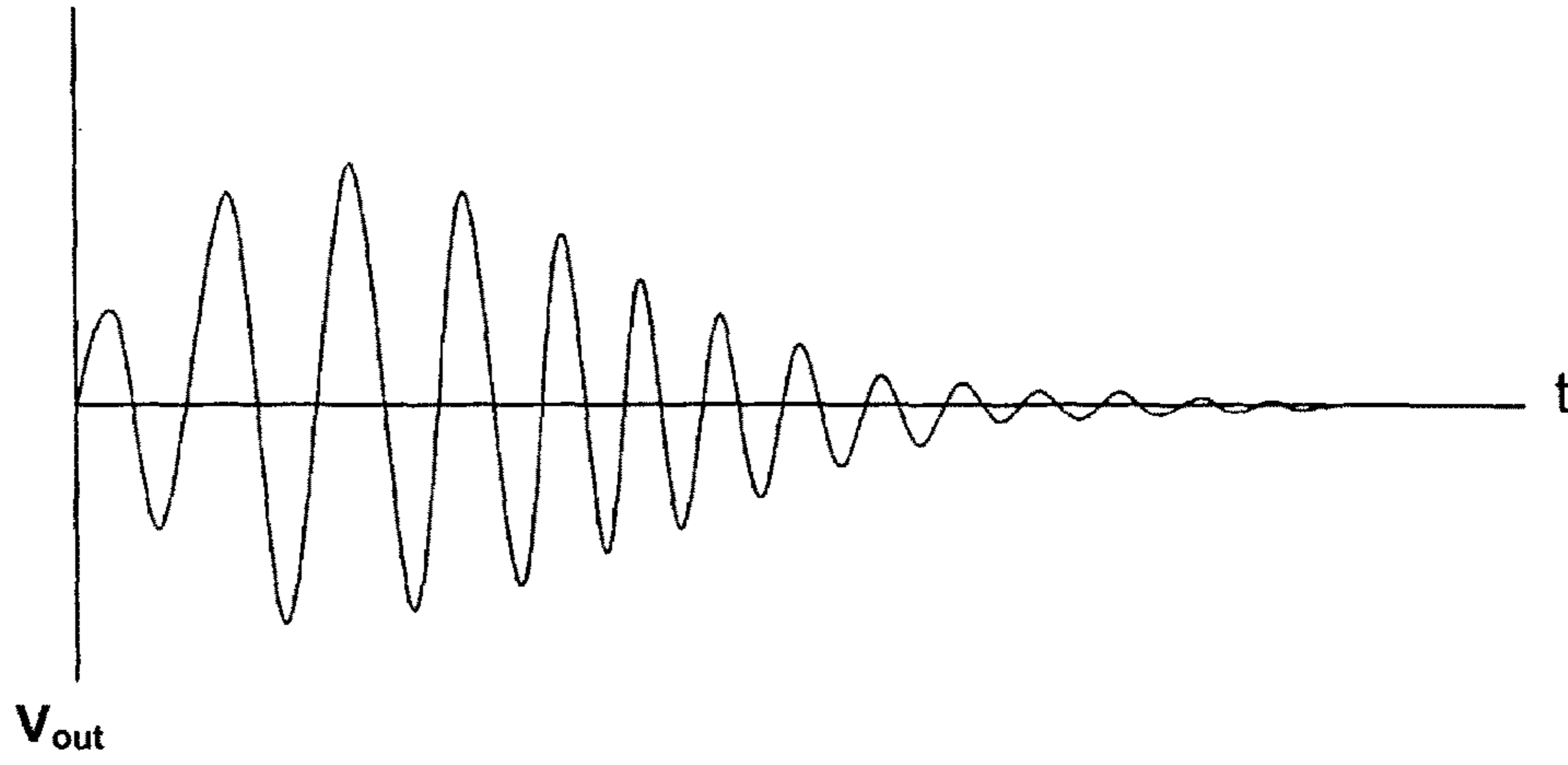

FIG. 10b

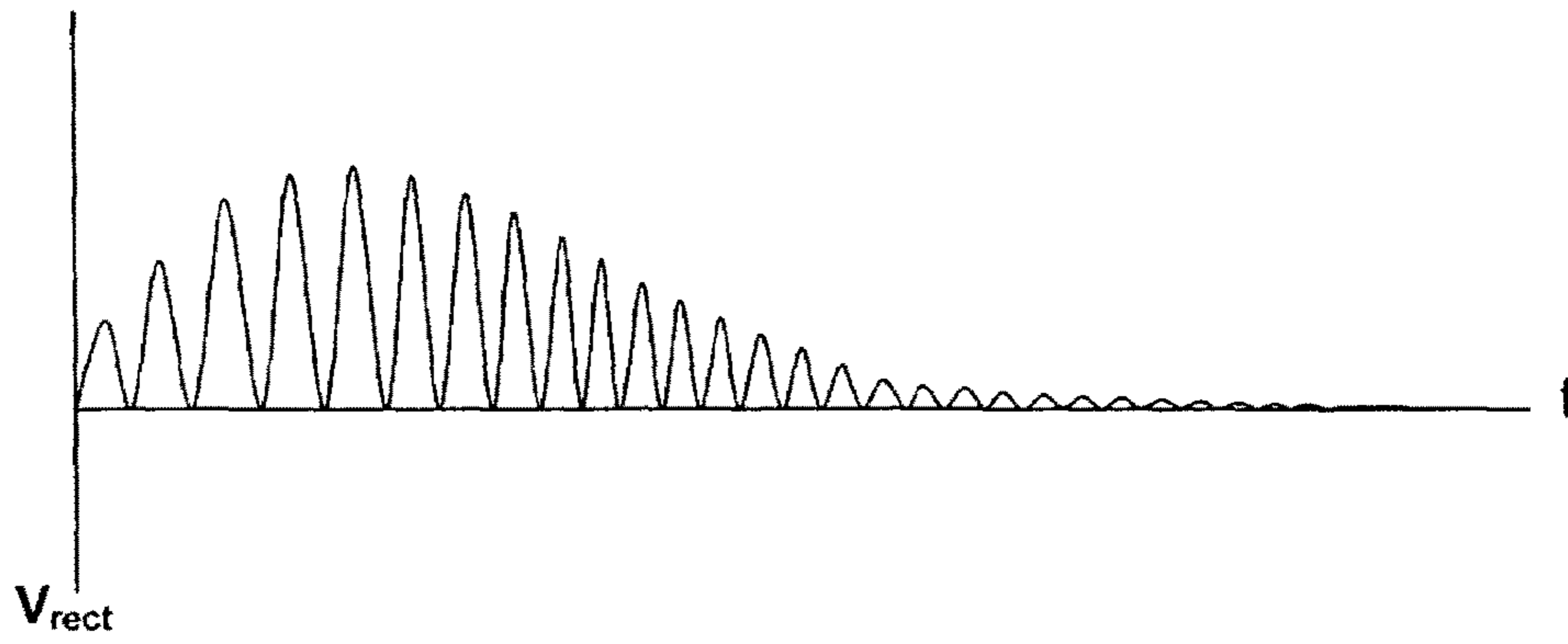

FIG. 10c

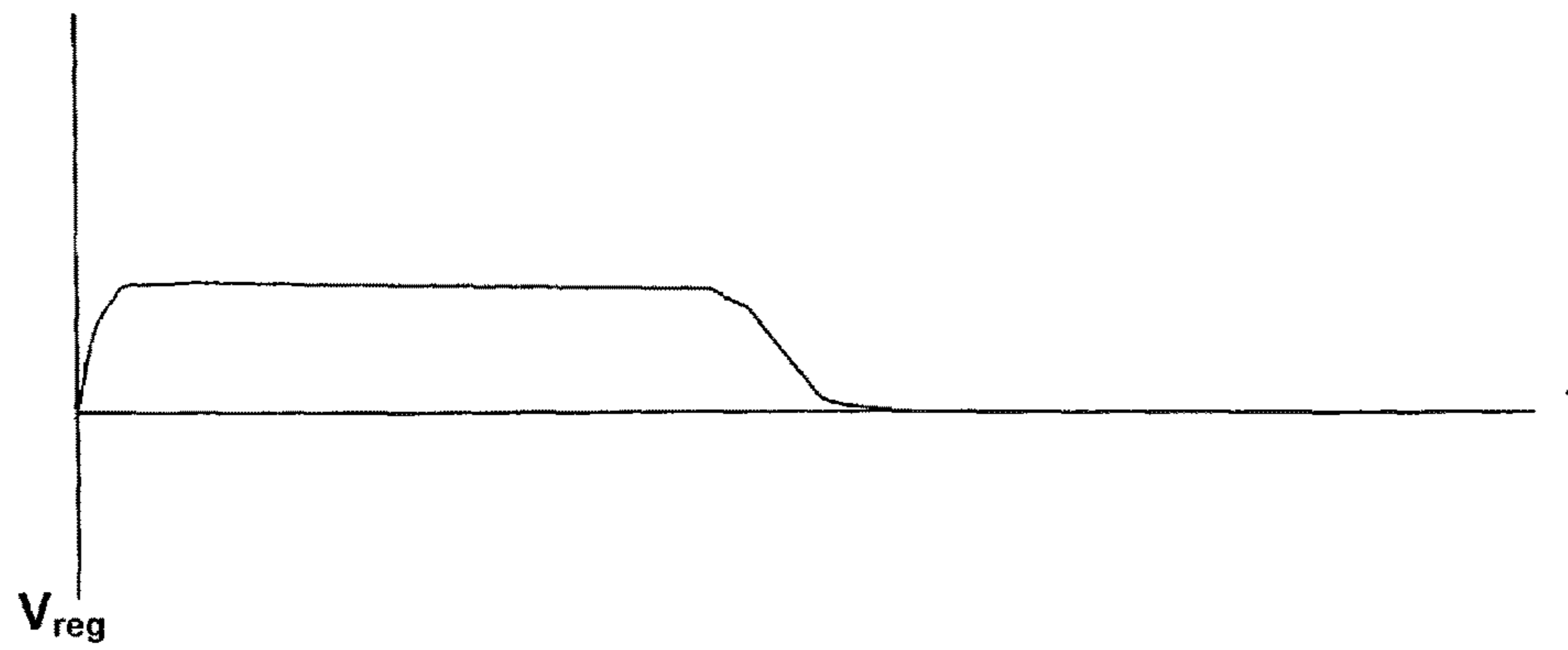

FIG. 11

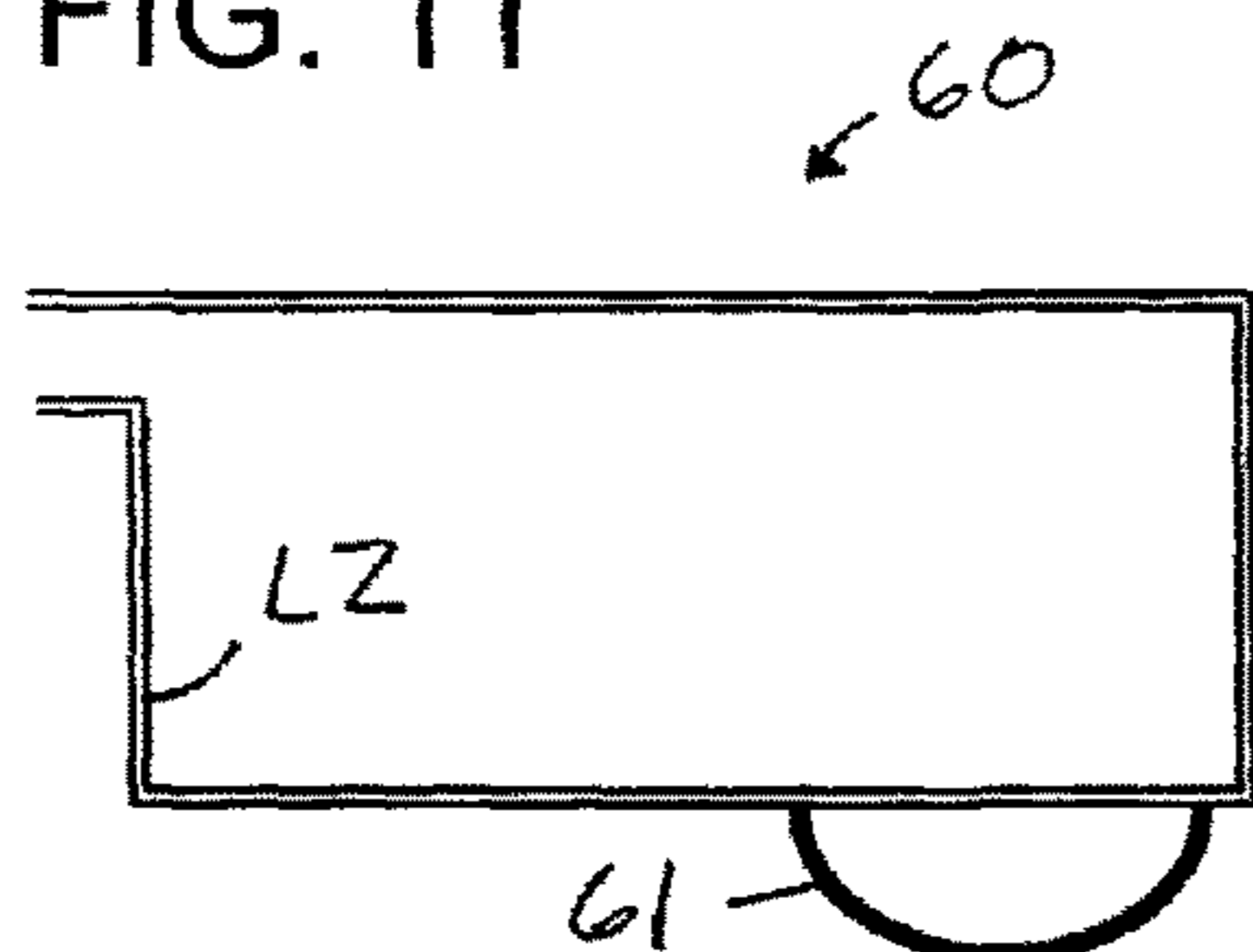

FIG. 12

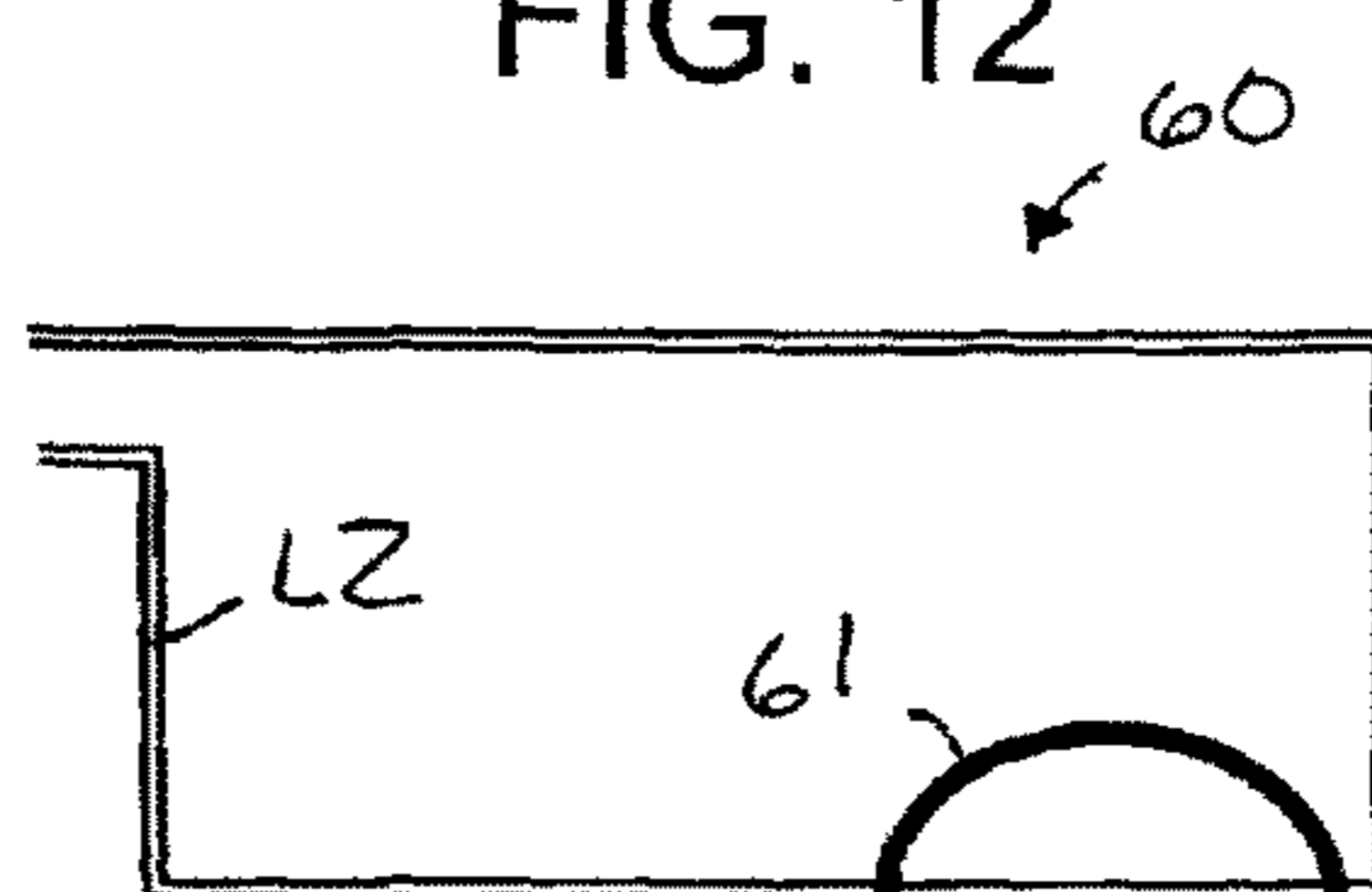

FIG. 13

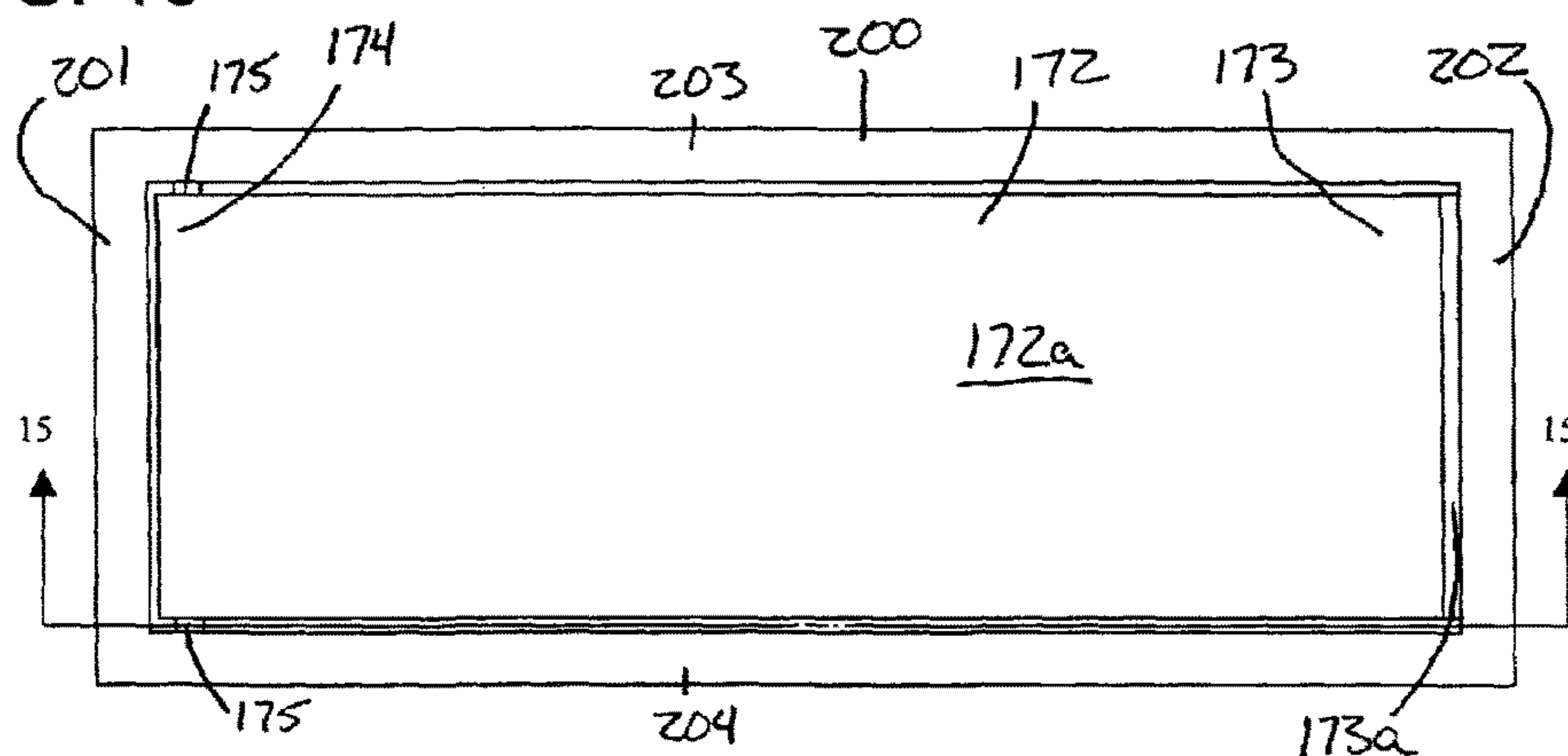

FIG. 14

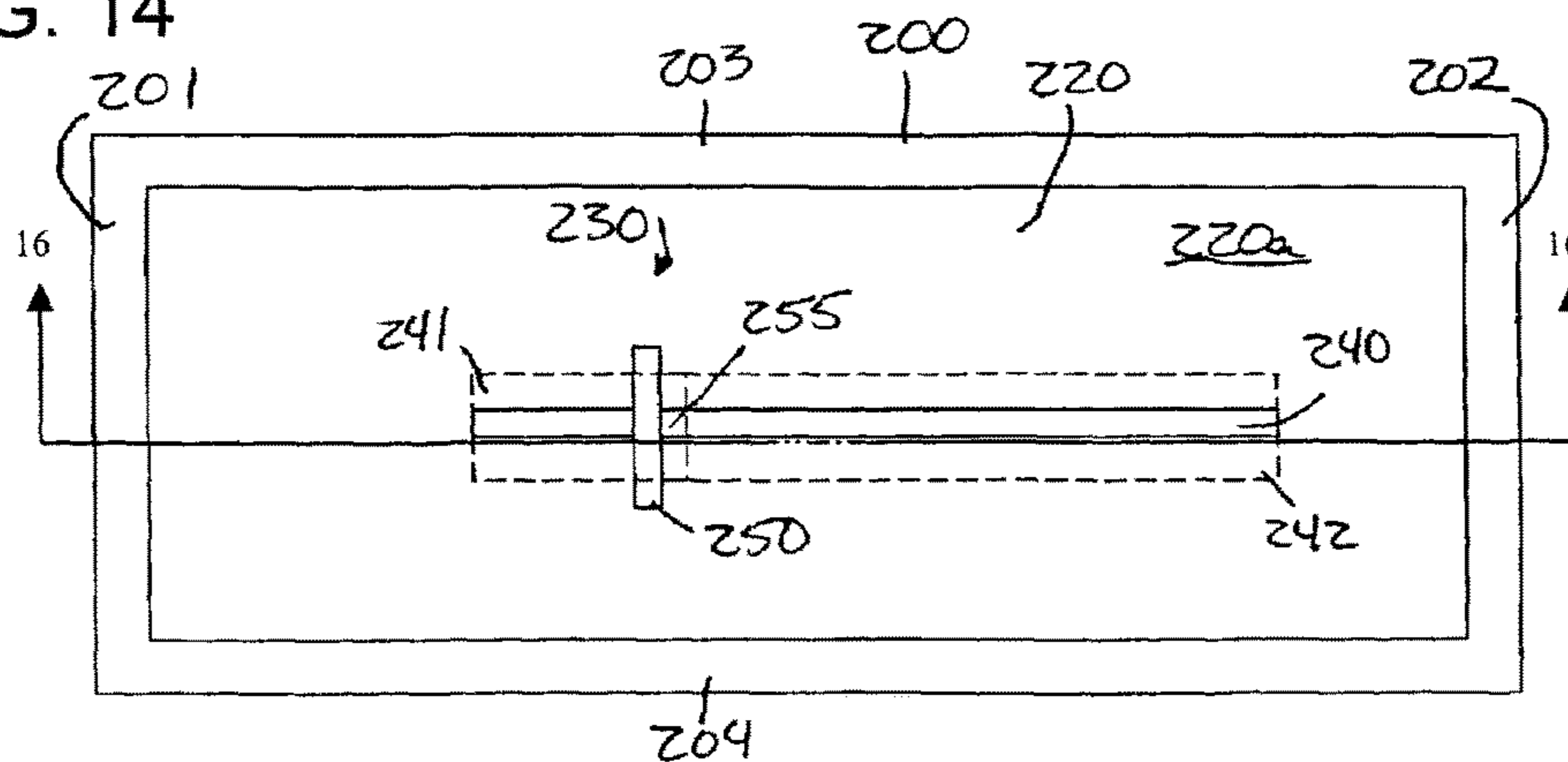

FIG. 15a

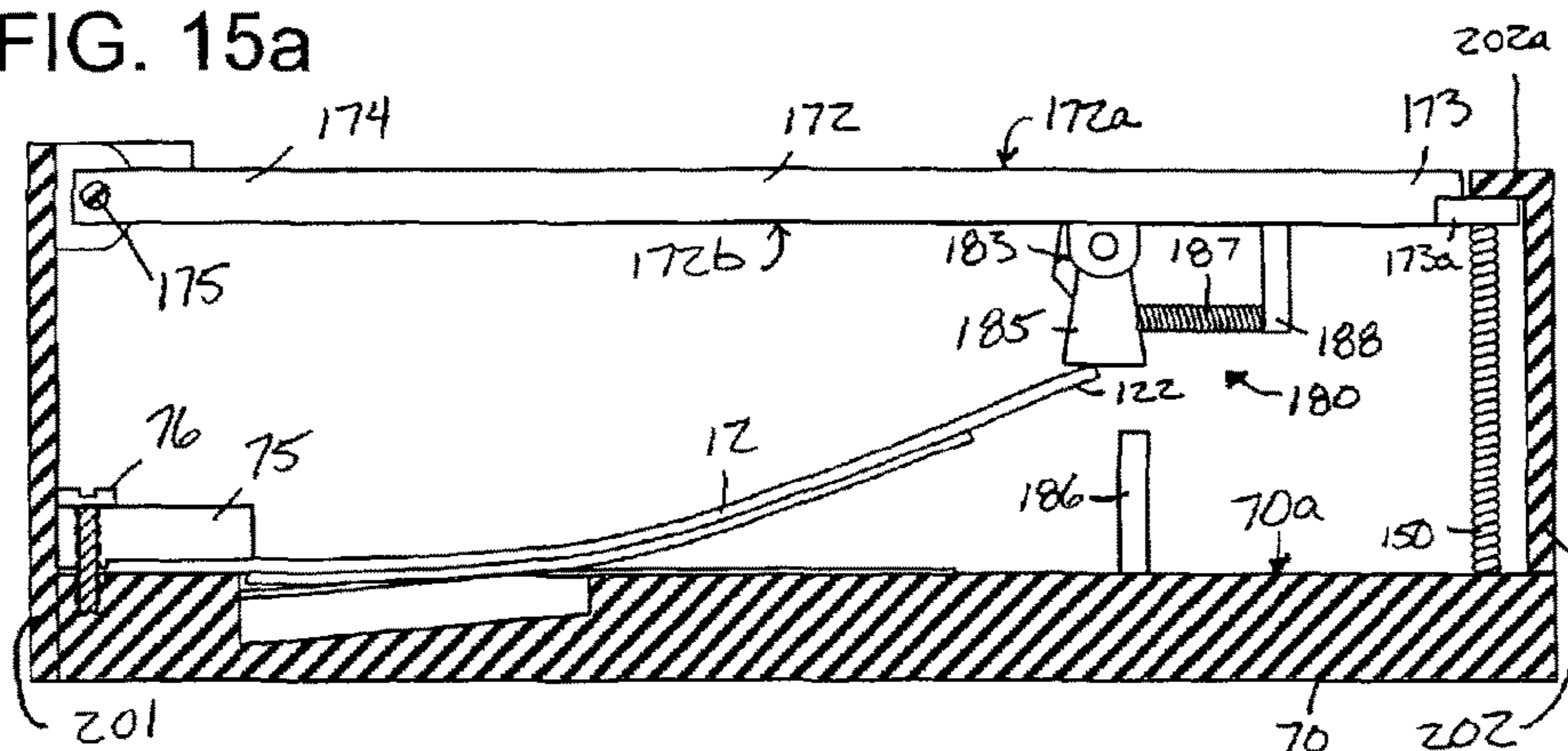

FIG. 15b

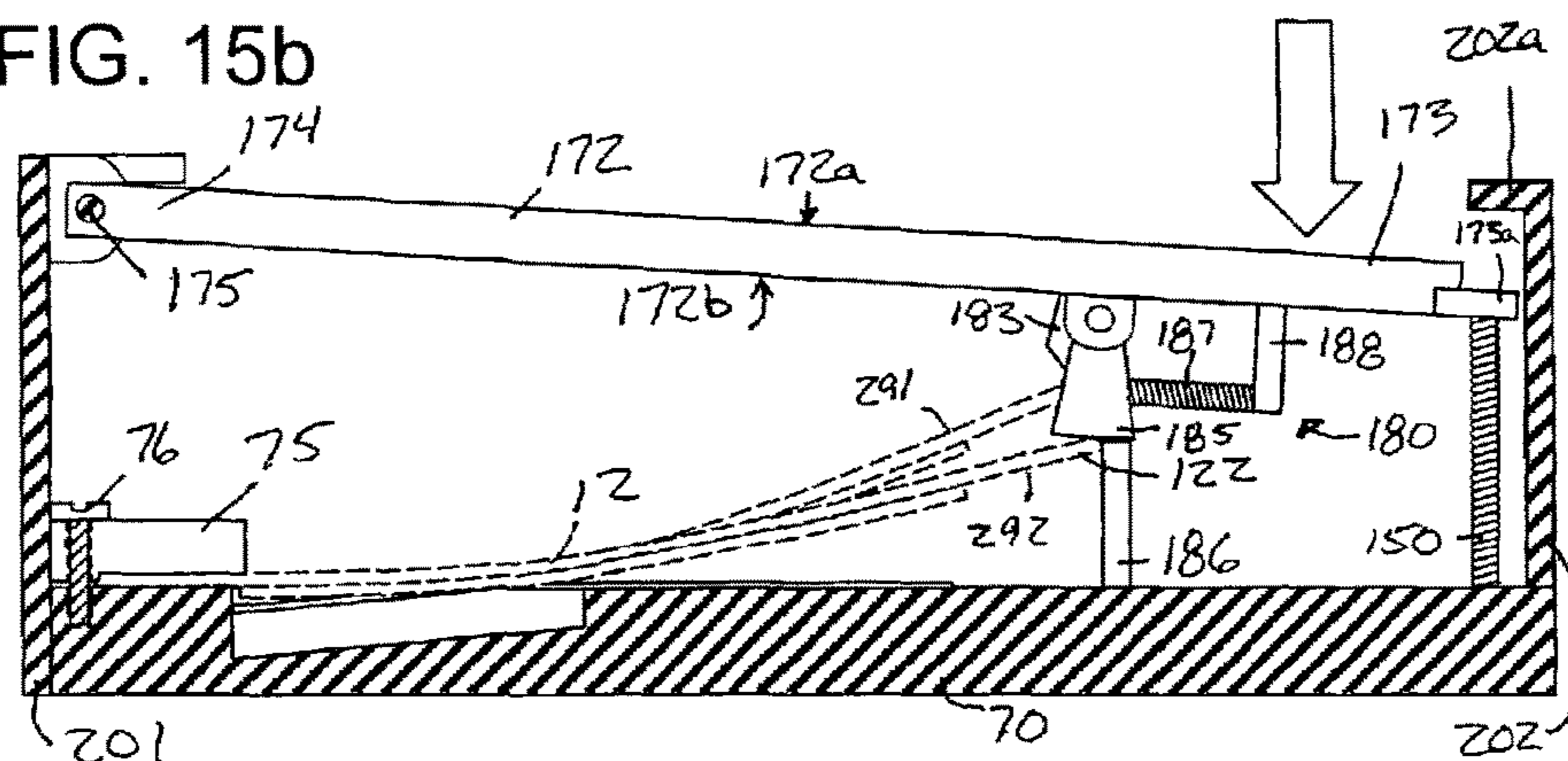
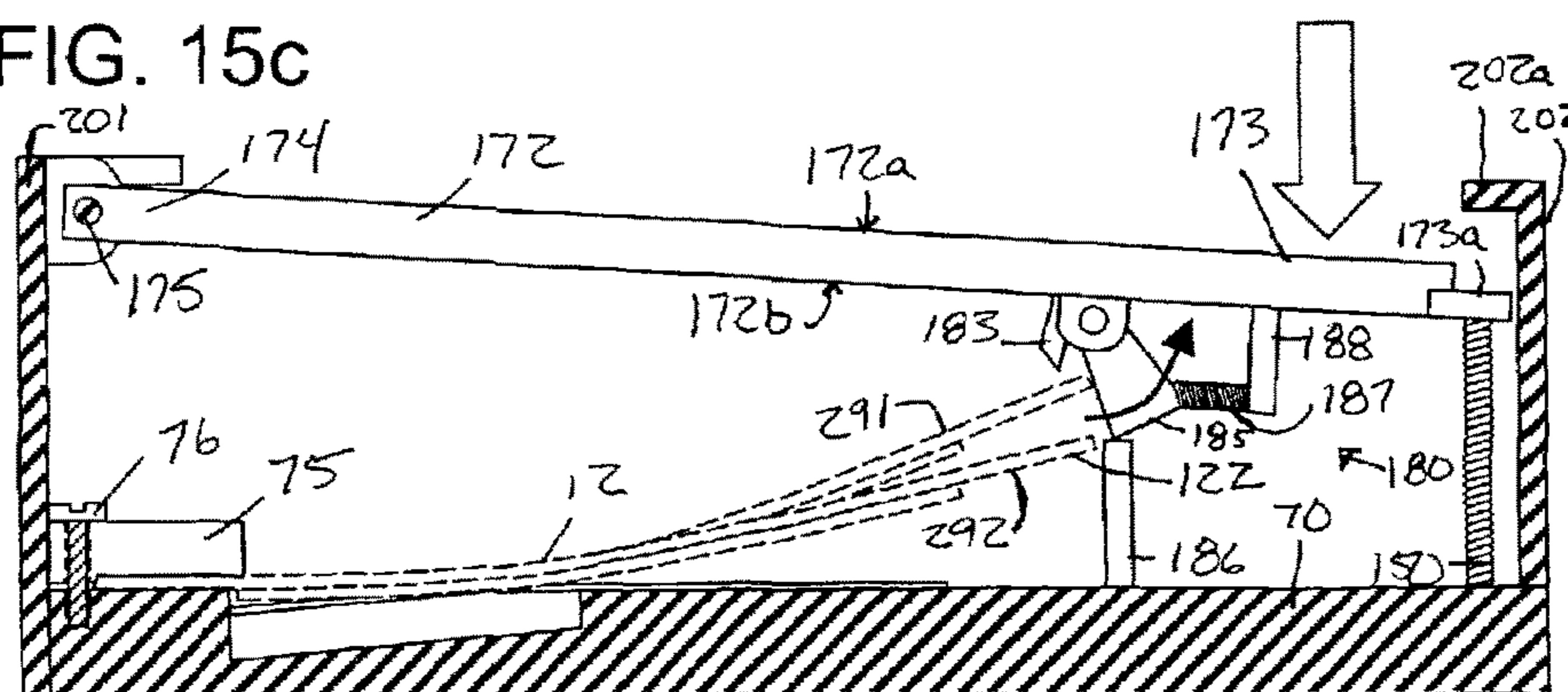
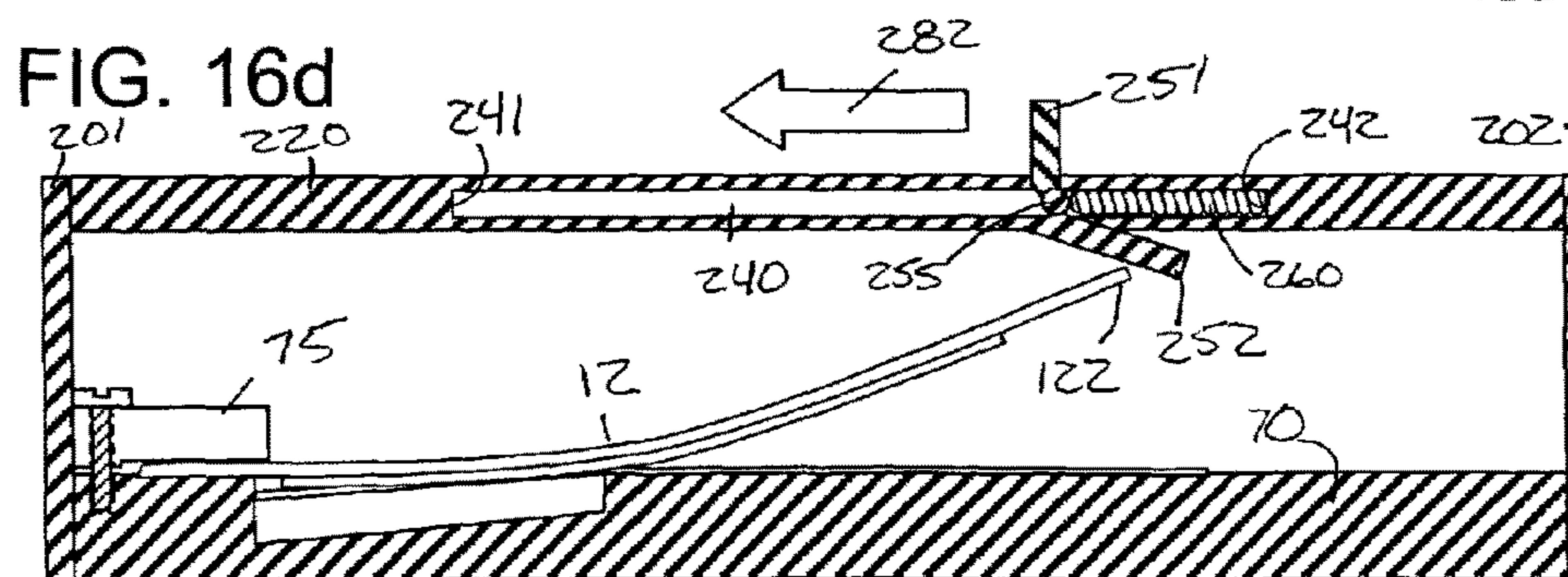
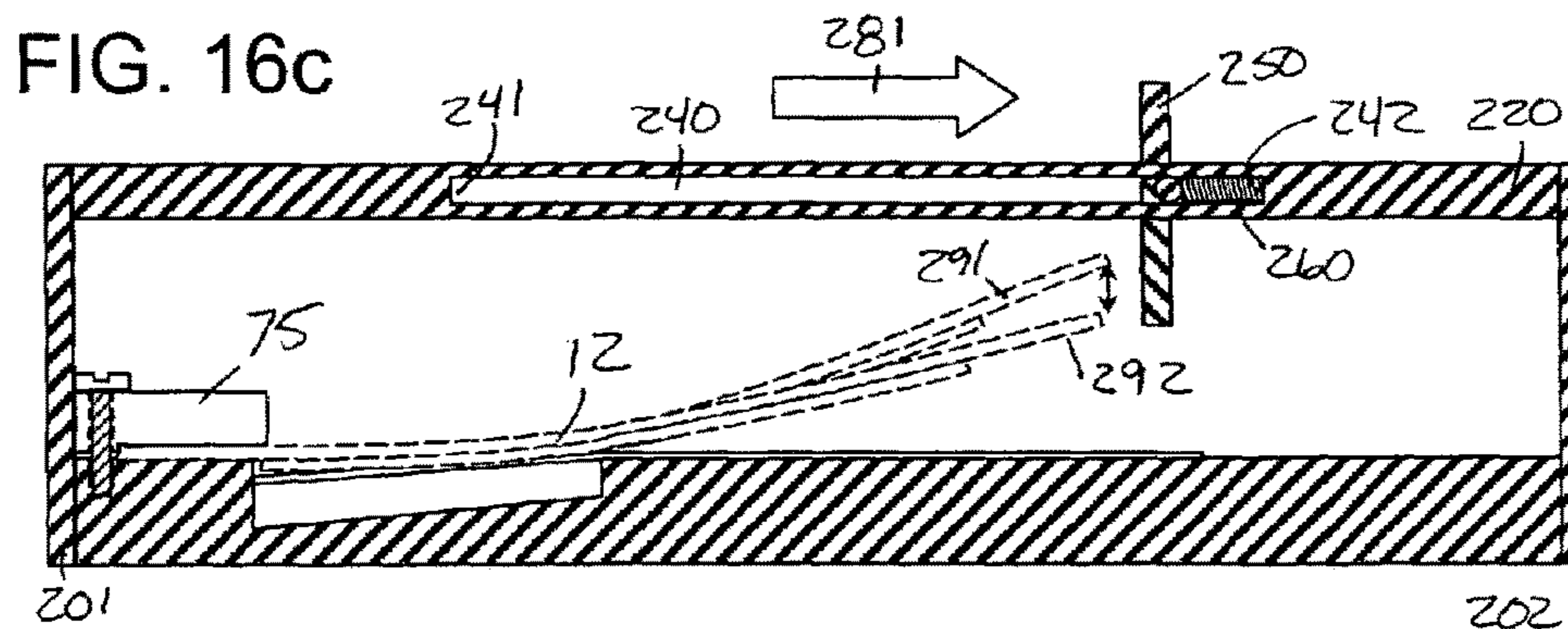
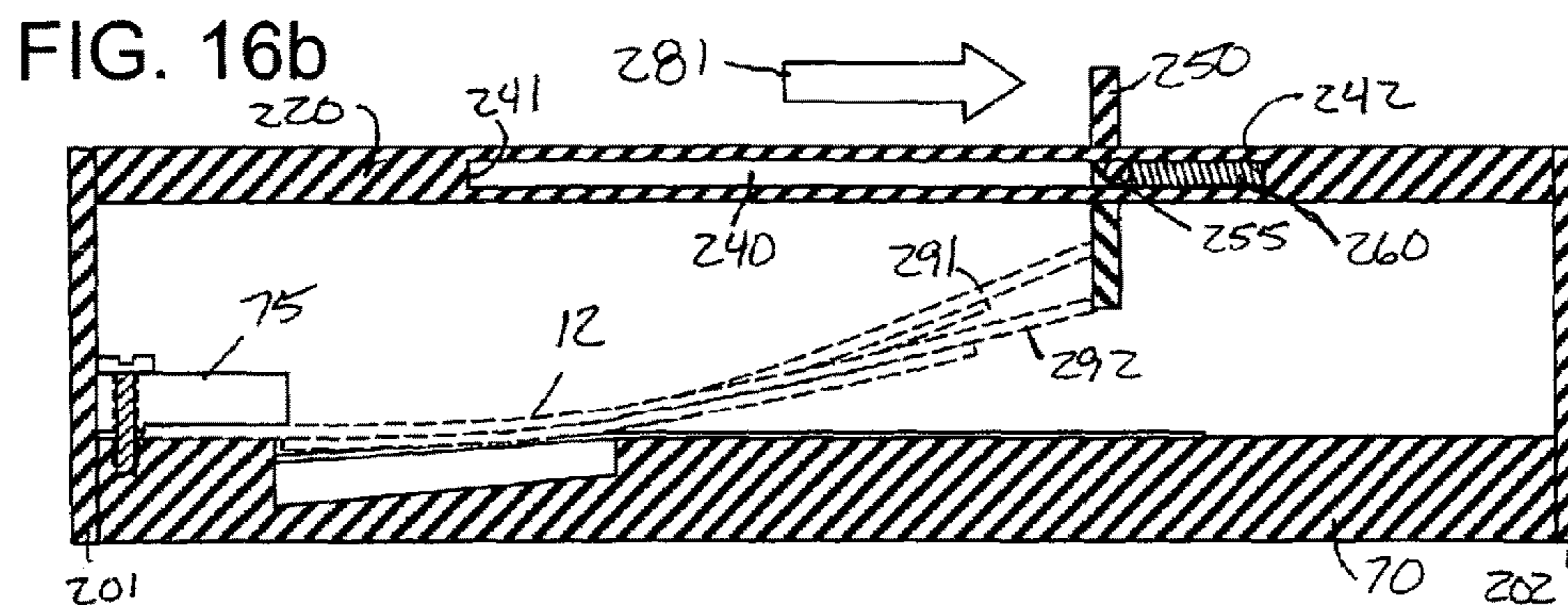
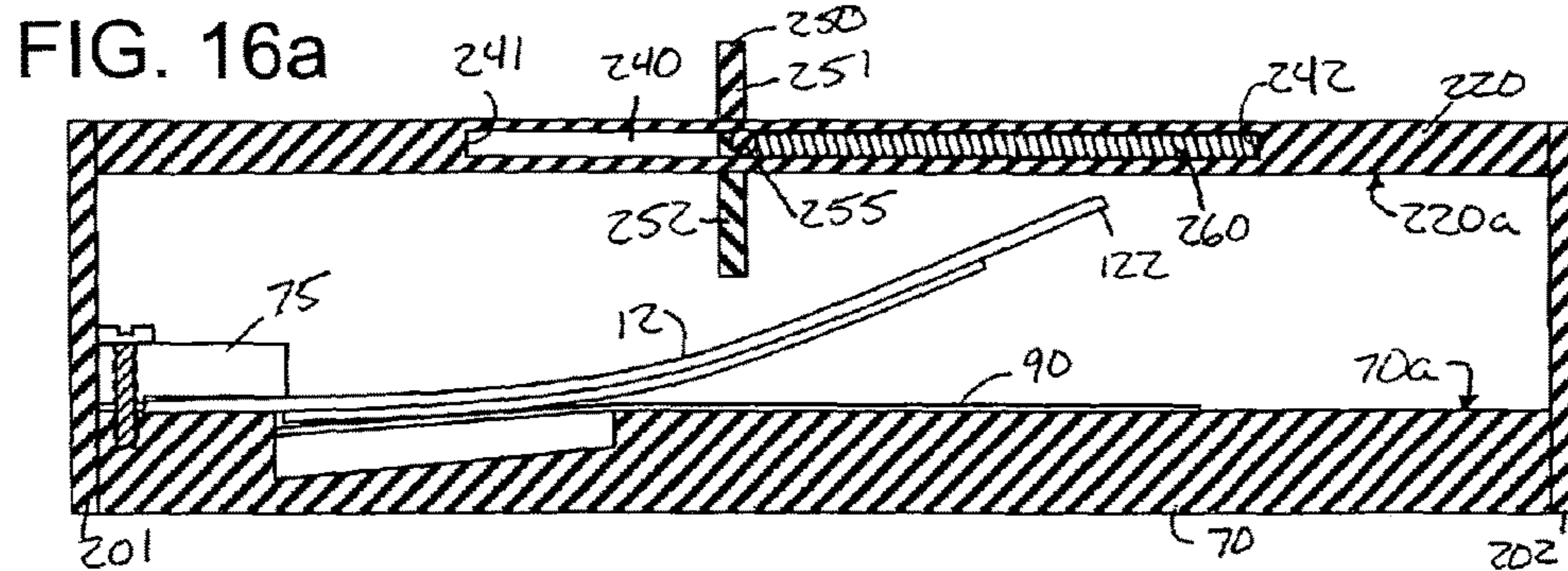

FIG. 15c





SELF-POWERED SWITCH INITIATION SYSTEM

Matter enclosed in heavy brackets [] appears in the original patent but forms no part of this reissue specification; matter printed in italics indicates the additions made by reissue; a claim printed with strikethrough indicates that the claim was canceled, disclaimed, or held invalid by a prior post-patent action or proceeding.

[This application claims priority from provisional application No. 60/302,990 filed Jul. 3, 2001.] *This is a continuation reissue application from Reissue application Ser. No. 12/183,574 filed Jul. 31, 2008, which is a reissue application of U.S. Pat. No. 7,084,529 B2 issued on Aug. 1, 2006, from U.S. application Ser. No. 10/188,633 filed Jul. 3, 2002, which claims the benefit of U.S. Provisional Application No. 60/302,990 filed Jul. 3, 2001, all of which are incorporated by reference herein in their entirety.*

BACKGROUND OF THE INVENTION

1. Field of the Invention

The present invention relates generally to switching devices for energizing lights, appliances and the like. More particularly, the present invention relates to a self-powered switch initiator device to generate an activation signal for a latching relay. The power is generated through a piezoelectric element and is sent through signal generation circuitry coupled to a transmitter for sending RF signal (which may be unique and/or coded) to one or more receivers that actuate the latching relay. The receivers are also trainable to respond to multiple transmitters.

2. Description of the Prior Art

Switches and latching relays for energizing lights, appliances and the like are well known in the prior art. Typical light switches comprise, for example, single-pole switches and three-way switches. A single-pole switch has two terminals that are hot leads for an incoming line (power source) and an outgoing line to the light. Three-way switches can control one light from two different places. Each three-way switch has three terminals: the common terminal and two traveler terminals. A typical pair of three-way switches uses two boxes each having two cables with the first box having an incoming line from a power source and an outbound line to the second box, and the second box having the incoming line from the first box and an outbound line to the light.

In each of these switching schemes it is often necessary to drill holes and mount switches and junction boxes for the outlets as well as running cable. Drilling holes and mounting switches and junction boxes can be difficult and time consuming. Also, running electrical cable requires starting at a fixture, pulling cable through holes in the framing to each fixture in the circuit, and continuing all the way back to the service panel. Though simple in theory, getting cable to cooperate can be difficult and time consuming. Cable often kinks, tangles or binds while pulling, and needs to be straightened out somewhere along the run.

Remotely actuated switches/relays are also known in the art. Known remote actuation controllers include tabletop controllers, wireless remotes, timers, motion detectors, voice activated controllers, and computers and related software. For example, remote actuation means may include modules that are plugged into a wall outlet and into which a power cord for a device may be plugged. The device can

then be turned on and off by a controller. Other remote actuation means include screw-in lamp modules wherein the module is screwed into a light socket, and then a bulb screwed into the module. The light can be turned on and off and can be dimmed or brightened by a controller.

An example of a typical remote controller for the above described modules is a radio frequency (RF) base transceiver. With these controllers, a base is plugged into an outlet and can control groups of modules in conjunction with a hand held wireless RF remote. RF repeaters may be used to boost the range of compatible wireless remotes, switches and security system sensors by up to 150 ft. per repeater. The base is required for all wireless RF remotes and allows control of several lamps or appliances. Batteries are also required in the hand held wireless remote.

Rather than using a hand held RF remote, remote wall switches may be used. These wall switches, which are up to 3/4" thick, are affixed to a desired location with an adhesive. In conjunction with a base unit (plugged into a 110V receptacle) the remote wall switch may control compatible modules or switches (receivers). The wireless switches send an RF signal to the base unit and the base unit then transmits a signal along the existing 110V wiring in the home to compatible switches or modules. Each switch can be set with an addressable signal. Wireless switches also require batteries.

These remotes control devices may also control, for example, audio/video devices such as the TV, VCR, and stereo system, as well as lights and other devices using an RF to infrared (IR) base. The RF remote can control audio/video devices by sending proprietary RF commands to a converter that translates the commands to IR. IR commands are then sent to the audio/video equipment. The console responds to infrared signals from the infrared remotes and then transmits equivalent commands to compatible receivers.

A problem with conventional wall switches is that extensive wiring must be run both from the switch boxes to the lights and from the switch boxes to the power source in the service panels.

Another problem with conventional wall switches is that additional wiring must be run for lights controlled by more than one switch.

Another problem with conventional wall switches is that the high voltage lines are present as an input to and an output from the switch.

Another problem with conventional wall switches is the cost associated with initial installation of wire to, from and between switches.

Another problem with conventional wall switches is the cost and inconvenience associated with remodeling, relocating or rewiring existing switches.

A problem with conventional RF switches is that they require an external power source such as high voltage AC power or batteries.

Another problem with conventional RF switches is the cost and inconvenience associated with replacement of batteries.

Another problem with conventional RF switches is that they require high power to individual modules and base units.

Another problem with conventional AC-powered RF switches is the difficulty when remodeling in rewiring or relocating a wall switch.

Another problem with conventional RF switches is that a pair comprising a transmitter and receiver must generally be purchased together.

Another problem with conventional RF switches is that transmitters may inadvertently activate incorrect receivers.

Another problem with conventional RF switches is that receivers may accept an activation signal from only one transmitter.

Another problem with conventional RF switches is that transmitters may activate only one receiver.

Accordingly, it would be desirable to provide a network of switch initiators and/or latching relay devices that overcomes the aforementioned problems of the prior art.

SUMMARY OF THE INVENTION

The present invention provides a self-powered switching initiator or latching relay device using an electroactive or electromagnetic actuator. The piezoelectric element in the electroactive actuator is capable of deforming with a high amount of axial displacement, and when deformed by a mechanical impulse generates an electric field. In an electromagnetic device, the relative motion between a magnet and a series of coils develops the electrical signal. The electroactive actuator is used as an electromechanical generator for generating a momentary signal that initiates a latching or relay mechanism. The latching or relay mechanism thereby turns electrical devices such as lights and appliances on and off or provides an intermediate or dimming signal.

The mechanical actuating means for the electroactive actuator element applies a suitable mechanical impulse to the electroactive actuator element in order to generate an electrical signal, such as a pulse or wave having sufficient magnitude and duration to actuate downstream circuit components. A switch similar to a light switch, for example, may apply pressure through a toggle, snap action, padded or plunger mechanism. Larger or multiple electroactive actuator elements may also be used to generate the electrical signal. Copending application Ser. No. 09/616,978 entitled "Self-Powered Switching Device," which is hereby incorporated by reference, discloses a self-powered switch where the electroactive element generates an electrical pulse. Copending provisional application 60/252,228 entitled "Self-Powered Trainable Switching Network," which is hereby incorporated by reference, discloses a network of switches such as that disclosed in the application 09/616,978, with the modification that the switches and receivers are capable accepting a multiplicity of coded RF signals. In the present invention, a modification has been developed to the mechanical actuation of the electroactive element resulting in a modification of the type of electrical signal produced by the actuator. The present invention describes a self-powered switch initiator having an electroactive element and accompanying circuitry designed to work with an oscillating electrical signal. To harness the power generated by the electroactive element, the accompanying RF signal generation circuitry has also been modified to use the electrical signal most efficiently.

In one embodiment of the invention, the electroactive actuator is depressed by the manual or mechanical actuating means and the oscillating electrical signal generated by the electroactive actuator is applied to the relay or switch through circuitry designed to modify the electrical signal. In yet another embodiment, the electromagnetic or electroactive actuator signal powers an RF transmitter which sends an RF signal to an RF receiver which then actuates the relay. In yet another embodiment, the electromagnetic or electroactive actuator signal powers a transmitter, which sends a pulsed RF signal to an RF receiver which then actuates the

relay. Digitized RF signals may be coded (as with a garage door opener) to only activate the relay that is coded with that digitized RF signal. The transmitters may be capable of developing one or more coded RF signals and the receivers likewise may be capable of receiving one or more coded RF signal. Furthermore, the receivers may be "trainable" to accept coded RF signals from new or multiple transmitters.

Accordingly, it is a primary object of the present invention to provide a switching or relay device in which an electroactive or piezoelectric element is used to activate the device.

It is another object of the present invention to provide a device of the character described in which switches may be installed without necessitating additional wiring.

It is another object of the present invention to provide a device of the character described in which switches may be installed without cutting holes into the building structure.

It is another object of the present invention to provide a device of the character described in which switches do not require external electrical input such as 120 or 220 VAC or batteries.

It is another object of the present invention to provide a device of the character described incorporating an electroactive device that generates an electrical signal of sufficient magnitude and duration to activate a latching relay and/or switch initiator.

It is another object of the present invention to provide a device of the character described incorporating an electroactive that generates an electrical signal of sufficient duration and magnitude to activate a radio frequency transmitter for activating a latching relay and/or switch initiator.

It is another object of the present invention to provide a device of the character described incorporating an actuator that generates an electrical signal of sufficient magnitude to activate a radio frequency transmitter for activating a latching relay and/or switch initiator.

It is another object of the present invention to provide a device of the character described incorporating a transmitter that is capable of developing at least one coded RF signal.

It is another object of the present invention to provide a device of the character described incorporating a receiver capable of receiving at least one coded RF signal from at least one transmitter.

It is another object of the present invention to provide a device of the character described incorporating a receiver capable of "learning" to accept coded RF signals from one or more transmitters.

It is another object of the present invention to provide a device of the character described for use in actuating lighting, appliances, security devices and other fixtures in a building.

Further objects and advantages of the invention will become apparent from a consideration of the drawings and ensuing description thereof.

BRIEF DESCRIPTION OF THE DRAWINGS

FIG. 1 is an elevation view showing the details of construction of a flextensional piezoelectric actuator used in the present invention;

FIG. 1a is an elevation view showing the details of construction of the flextensional piezoelectric actuator of FIG. 1 having an additional prestress layer;

FIG. 2 is an elevation view showing the details of construction of an alternate multi-layer flextensional piezoelectric actuator used in a modification the present invention;

5

FIG. 3 is an elevation view of an embodiment of a device for mechanical application and removal of a force to the center of an actuator;

FIG. 4 is an elevation view of the device of FIG. 3 illustrating the deformation of the actuator upon application of a force;

FIG. 5 is an elevation view of the device of FIG. 3 illustrating the recovery of the actuator upon removal of the force by tripping of a quick-release device;

FIG. 6 is an elevation view of the actuating device of the present invention for generation of an electrical signal by deflecting a flextensional piezoelectric actuator;

FIG. 7 is an elevation view of the preferred actuating device of the present invention for generation of an electrical signal by deflecting a flextensional piezoelectric actuator;

FIG. 8 is a block diagram showing the components of a circuit for using the electrical signal generated by the device of FIG. 6 or 7;

FIG. 9 a detailed circuit diagram of the circuit in FIG. 8;

FIGS. 10a-c show the electrical signal generated by the actuator, the rectified electrical signal and the regulated electrical signal respectively;

FIG. 11 is a plan view of a tuned loop antenna of FIG. 8 illustrating the jumper at a position maximizing the inductor cross-section;

FIG. 12 is a plan view of the tuned loop antenna of FIG. 8 illustrating the jumper at a position minimizing the inductor cross-section;

FIG. 13 is an elevation view of a preferred deflector assembly and casing which enclose the actuator of the present invention;

FIG. 14 is an elevation view of an alternate embodiment a deflector assembly using a sliding paddle;

FIGS. 15a-c are elevational cross-sections taken along line 15-15 of FIG. 13 showing the preferred embodiment of a casing and deflector assembly using a quick release mechanism; and

FIGS. 16a-d are elevational cross-sections taken along line 16-16 of FIG. 14.

DESCRIPTION OF THE PREFERRED EMBODIMENT

Electroactive Actuator

Piezoelectric and electrostrictive materials (generally called "electroactive" devices herein) develop a polarized electric field when placed under stress or strain. The electric field developed by a piezoelectric or electrostrictive material is a function of the applied force causing the mechanical stress or strain. Conversely, electroactive devices undergo dimensional changes in an applied electric field. The dimensional change (i.e., expansion or contraction) of an electroactive device is a function of the applied electric field. Electroactive devices are commonly used as drivers, or "actuators" due to their propensity to deform under such electric fields. These electroactive devices or actuators also have varying capacities to generate an electric field in response to a deformation caused by an applied force.

Electroactive devices include direct and indirect mode actuators, which typically make use of a change in the dimensions of the material to achieve a displacement, but in the present invention are preferably used as electromechanical generators. Direct mode actuators typically include a piezoelectric or electrostrictive ceramic plate (or stack of plates) sandwiched between a pair of electrodes formed on its major surfaces. The devices generally have a sufficiently large piezoelectric and/or electrostrictive coefficient to pro-

6

duce the desired strain in the ceramic plate. However, direct mode actuators suffer from the disadvantage of only being able to achieve a very small displacement (strain), which is, at best, only a few tenths of a percent. Conversely, direct mode generator-actuators require application of a high amount of force to piezoelectrically generate a pulsed momentary electrical signal of sufficient magnitude to activate a latching relay.

Indirect mode actuators are known to exhibit greater displacement and strain than is achievable with direct mode actuators by achieving strain amplification via external structures. An example of an indirect mode actuator is a flextensional transducer. Flextensional transducers are composite structures composed of a piezoelectric ceramic 32 element and a metallic shell, stressed plastic, fiberglass, or similar structures. The actuator movement of conventional flextensional devices commonly occurs as a result of expansion in the piezoelectric material which mechanically couples to an amplified contraction of the device in the transverse direction. In operation, they can exhibit several orders of magnitude greater strain and displacement than can be produced by direct mode actuators.

The magnitude of achievable strain of indirect mode actuators can be increased by constructing them either as "unimorph" or "bimorph" flextensional actuators. A typical unimorph is a concave structure composed of a single piezoelectric element externally bonded to a flexible metal foil, and which results in axial buckling or deflection when electrically energized. Common unimorphs can exhibit a strain of as high as 10%. A conventional bimorph device includes an intermediate flexible metal foil sandwiched between two piezoelectric elements. Electrodes are bonded to each of the major surface of the ceramic elements and the metal foil is bonded to the inner two electrodes. Bimorphs exhibit more displacement than comparable unimorphs because under the applied voltage, one ceramic element will contract while the other expands. Bimorphs can exhibit strains up to 20%.

For certain applications of electroactive actuators, asymmetrically stress biased electroactive devices have been proposed in order to increase the axial deformation of the electroactive material, and therefore increase the achievable strain of the electroactive material. In such devices, (which include, for example, "Rainbow" actuators (as disclosed in U.S. Pat. No. 5,471,721), and other flextensional actuators) the asymmetric stress biasing produces a curved structure, typically having two major surfaces, one of which is concave and the other which is convex.

Referring to FIG. 1: A unimorph actuator called "THUNDER", which has improved displacement, strain and load capabilities, has recently been developed and is disclosed in U.S. Pat. No. 5,632,841. THUNDER (which is an acronym for THin layer composite UNimorph ferroelectric Driver and sEnsoR), is a unimorph actuator in which a pre-stress layer is bonded to a thin piezoelectric ceramic wafer at high temperature, and during the cooling down of the composite structure asymmetrically stress biases the ceramic wafer due to the difference in thermal contraction rates of the pre-stress layer and the ceramic layer.

The THUNDER actuator 12 is as a composite structure, the construction of which is illustrated in FIG. 1. Each THUNDER actuator 12 is constructed with an electroactive member preferably comprising a piezoelectric ceramic layer 67 of PZT which is electroplated 65 and 65a on its two opposing faces. A pre-stress layer 64, preferably comprising spring steel, stainless steel, beryllium alloy or other metal substrate, is adhered to the electroplated 65 surface on one

side of the ceramic layer 67 by a first adhesive layer 66. In the simplest embodiment, the adhesive layer 66 acts as a prestress layer. The first adhesive layer 66 is preferably LaRC™-SI material, as developed by NASA-Langley Research Center and disclosed in U.S. Pat. No. 5,639,850. A second adhesive layer 66a, also preferably comprising LaRC-SI material, is adhered to the opposite side of the ceramic layer 67. During manufacture of the THUNDER actuator 12 the ceramic layer 67, the adhesive layer(s) 66 and 66a and the pre-stress layer 64 are simultaneously heated to a temperature above the melting point of the adhesive material. In practice the various layers composing the THUNDER actuator (namely the ceramic layer 67, the adhesive layers 66 and 66a and the pre-stress layer 64) are typically placed inside of an autoclave or a convection oven as a composite structure, and slowly heated by convection until all the layers of the structure reach a temperature which is above the melting point of the adhesive 66 material but below the Curie temperature of the ceramic layer 67. It is desirable to keep the temperature of the ceramic layer 67 beneath the Curie temperature of the ceramic layer in order to avoid disrupting the piezoelectric characteristics of the ceramic layer 67. Because the multi-layer structure is typically convectively heated at a slow rate, all of the layers tend to be at approximately the same temperature. In any event, because an adhesive layer 66 is typically located between two other layers (i.e. between the ceramic layer 67 and the pre-stress layer 64), the ceramic layer 67 and the pre-stress layer 64 are usually very close to the same temperature and are at least as hot as the adhesive layers 66 and 66a during the heating step of the process. The THUNDER actuator 12 is then allowed to cool.

During the cooling step of the process (i.e. after the adhesive layers 66 and 66a have re-solidified) the ceramic layer 67 becomes compressively stressed by the adhesive layers 66 and 66a and pre-stress layer 64 due to the higher coefficient of thermal contraction of the materials of the adhesive layers 66 and 66a and the pre-stress layer 64 than for the material of the ceramic layer 67. Also, due to the greater thermal contraction of the laminate materials (e.g. the first pre-stress layer 64 and the first adhesive layer 66) on one side of the ceramic layer 67 relative to the thermal contraction of the laminate material(s) (e.g. the second adhesive layer 66a) on the other side of the ceramic layer 67, the ceramic layer deforms in an arcuate shape having a normally convex face 12a and a normally concave face 12c, as illustrated in FIGS. 1 and 2.

Referring to FIG. 1a: One or more additional pre-stressing layer(s) may be similarly adhered to either or both sides of the ceramic layer 67 in order, for example, to increase the stress in the ceramic layer 67 or to strengthen the actuator 12B. In a preferred embodiment of the invention, a second prestress layer 68 is placed on the concave face 12c of the actuator 12B having the second adhesive layer 66a and is similarly heated and cooled. Preferably the second prestress layer 68 comprises a layer of conductive metal. More preferably the second prestress layer 68 comprises a thin foil (relatively thinner than the first prestress layer 64) comprising aluminum or other conductive metal. During the cooling step of the process (i.e. after the adhesive layers 66 and 66a have re-solidified) the ceramic layer 67 similarly becomes compressively stressed by the adhesive layers 66 and 66a and pre-stress layers 64 and 68 due to the higher coefficient of thermal contraction of the materials of the adhesive layers 66 and 66a and the pre-stress layers 64 and 68 than for the material of the ceramic layer 67. Also, due to the greater thermal contraction of the laminate materials (e.g. the first

prestress layer 64 and the first adhesive layer 66) on one side of the ceramic layer 67 relative to the thermal contraction of the laminate material(s) (e.g. the second adhesive layer 66a and the second prestress layer 68) on the other side of the ceramic layer 67, the ceramic layer 67 deforms into an arcuate shape having a normally convex face 12a and a normally concave face 12c, as illustrated in FIG. 1a.

Alternatively, the substrate comprising a separate prestress layer 64 may be eliminated and the adhesive layers 66 and 66a alone or in conjunction may apply the prestress to the ceramic layer 67. Alternatively, only the prestress layer(s) 64 and 68 and the adhesive layer(s) 66 and 66a may be heated and bonded to a ceramic layer 67, while the ceramic layer 67 is at a lower temperature, in order to induce greater compressive stress into the ceramic layer 67 when cooling the actuator 12.

Referring now to FIG. 2: Yet another alternate actuator 12D includes a composite piezoelectric ceramic layer 69 that comprises multiple thin layers 69a and 69b of PZT which are bonded to each other. Each layer 69a and 69b comprises a thin layer of piezoelectric material, with a thickness preferably on the order of about 1 mil. Each thin layer 69a and 69b is electroplated 65 and 65a, and 65b and 65c on each major face respectively. The individual layers 69a and 69b are then bonded to each other with an adhesive layer 66b, using an adhesive such as LaRC-SI. Alternatively, and most preferably, the thin layers 69a and 69b may be bonded to each other by cofiring the thin sheets of piezoelectric material together. As few as two layers 69a and 69b, but preferably at least four thin sheets of piezoelectric material may be bonded/cofired together. The composite piezoelectric ceramic layer 69 may then be bonded to prestress layer(s) 64 with the adhesive layer(s) 66 and 66a, and heated and cooled as described above to make a modified THUNDER actuator 12D. By having multiple thinner layers 69a and 69b of piezoelectric material in a modified actuator 12D, the composite ceramic layer generates a lower voltage and higher current as compared to the high voltage and low current generated by a THUNDER actuator 12 having only a single thicker ceramic layer 67.

A flexible insulator may be used to coat the convex face 12a of the actuator 12. This insulative coating helps prevent unintentional discharge of the piezoelectric element through inadvertent contact with another conductor, liquid or human contact. The coating also makes the ceramic element more durable and resistant to cracking or damage from impact. Since LaRC-SI is a dielectric, the adhesive layer 67a on the convex face 12a of the actuator 12 may act as the insulative layer. Alternately, the insulative layer may comprise a plastic, TEFLON or other durable coating.

Electrical energy may be recovered from or introduced to the actuator element 12 by a pair of electrical wires 14. Each electrical wire 14 is attached at one end to opposite sides of the actuator element 12. The wires 14 may be connected (for example by glue or solder 20) directly to the electroplated 65 and 65a faces of the ceramic layer 67, or they may alternatively be connected to the pre-stress layer(s) 64. As discussed above, the prestress layer 64 is preferably adhered to the ceramic layer 67 by LaRC-SI material, which is a dielectric. When the wires 14 are connected to the pre-stress layer(s) 64, it is desirable to roughen a face of the pre-stress layer 64, so that the pre-stress layer 64 intermittently penetrates the respective adhesive layers 66 and 66a, and make electrical contact with the respective electroplated 65 and 65a faces of the ceramic layer 67. Alternatively, the Larc-SI adhesive layer 66 may have a conductive material, such as Nickel or aluminum particles, used as a filler in the adhesive

and to maintain electrical contact between the prestress layer and the electroplated face of the ceramic. The opposite end of each electrical wire 14 is preferably connected to an electric pulse modification circuit 10.

Prestressed flextensional transducers 12 are desirable due to their durability and their relatively large displacement, and concomitant relatively high voltage that such transducers are capable of developing. The present invention however may be practiced with any electroactive element having the properties and characteristics herein described, i.e., the ability to generate a voltage in response to a deformation of the device. For example, the invention may be practiced using magnetostrictive or ferroelectric devices. The transducers also need not be normally arcuate, but may also include transducers that are normally flat, and may further include stacked piezoelectric elements.

In operation, as shown in FIG. 4, when a force indicated by arrow 16 is applied to the convex face 12a of the actuator 12, the force deforms the piezoelectric element 67. The force may be applied to the piezoelectric actuator 12 by any appropriate means such as by application of manual pressure directly to the piezoelectric actuator, or by other mechanical means. Preferably, the force is applied by a mechanical switch (e.g., a plunger, striker, toggle or roller switch) capable of developing a mechanical impulse for application to and removal from the actuator 12. The mechanical impulse (or removal thereof) is of sufficient force to cause the actuator 12 to deform quickly and accelerate over a distance (approximately 10 mm) which generates an electrical signal of sufficient magnitude to activate an electro-mechanical latching relay.

Referring to FIGS. 3, 4 and 5: An illustration of prior means generating an electrical pulse by application of mechanical force comprises a switch plate 18 and a plunger assembly 13. The two ends of the piezoelectric actuator are each pivotably held in place within a recess 44 of a switch plate 18. The switch plate 18 is the same shape as the actuator 12 contained therein, preferably rectangular. Alternatively, a circular actuator is mounted in a circular recess of a circular switch plate. The recess(es) 44 in the switch plate 18 hold the actuator 12 in place in its relaxed, i.e., undeformed state. The recesses 44 are also sufficiently deep to fully receive the ends or edges of the actuator 12 in its fully deformed, i.e., flat state. The plunger assembly comprises a push button 22 pivotably connected to a hinged quick-release mechanism 24. The opposite end of the quick-release mechanism 24 contacts shaft 26 connected to a pair of plates 27 and 28 which are clamped on both sides of the actuator 12. A release cog 25 is located along the path of the quick-release mechanism 24.

In operation, when the push button 22 is depressed in the direction of arrow 16, the quick-release mechanism 24 pushes down on the shaft 26 and plates 27 and 28 and deforms the actuator 12. When the quick-release mechanism 24 reaches the release cog 25, the quick-release mechanism 24 pivots on its hinge and releases the downward pressure from the shaft 26, plates 27 and 28 and actuator 12. The actuator 12, on account of the restoring force of the substrate of the prestress layer 64, returns quickly to its undeformed state in the direction of arrow 30 as in FIG. 5.

As previously mentioned, the applied force causes the piezoelectric actuator 12 to deform. By virtue of the piezoelectric effect, the deformation of the piezoelectric element 67 generates an instantaneous voltage between the faces 12a and 12c of the actuator 12, which produces a pulse of electrical energy. Furthermore, when the force is removed from the piezoelectric actuator 12, the actuator 12 recovers

its original arcuate shape. This is because the substrate or prestress layers 64 and 68 to which the ceramic 67 is bonded exert a compressive force on the ceramic 67, and the actuator 12 thus has a coefficient of elasticity that causes the actuator 12 to return to its undeformed neutral state. On the recovery stroke of the actuator 12, the ceramic 67 returns to its undeformed state and thereby produces another electrical pulse of opposite polarity. The downward (applied) or upward (recovery) strokes should cause a force over a distance that is of sufficient magnitude to create the desired electrical pulse. The duration of the recovery stroke, and therefore the duration of the pulse produced, is preferably in the range of 50-100 milliseconds, depending on the amount of force applied to the actuator 12.

Referring to FIG. 6.: In the preferred embodiment of the invention, the actuator 12 is clamped at one end 121 and the mechanical impulse is applied to the edge on the free end 122, i.e., at the end opposite to the clamped end 121 of the actuator 12. By applying the force to the edge on the free end 122 of the actuator 12 and releasing it, the electrical pulse that is generated upon removal of the force is an oscillating wave rather than a single pulse as in the prior actuating means disclosed above.

Referring again to FIG. 6: FIG. 6 illustrates one embodiment of a device for generating an electrical pulse by application of mechanical force to an end of the actuator 12. This device comprises an actuator 12 mounted between a base plate 70 and a clamping member 75 as well as a deflector assembly 72. The base plate 70 is preferably of substantially the same shape (in plan view) as the actuator 12 attached thereon, and most preferably rectangular. One end 121 of the piezoelectric actuator 12 is held in place between the clamping member 75 and the upper surface 70a of a base plate 70, preferably on one end thereof. The clamping member 75 comprises a plate or block having a lower surface 75a designed to mate with the upper surface 70a of the base plate 70 with the actuator 12 therebetween. The device also has means for urging 76 the mating surface 75a of the clamping block towards the upper surface 70a of the base plate 70. This allows the lower surface 75a of the clamping plate 75 to be substantially rigidly coupled to the upper surface 70a of the base plate 70, preferably towards one side of the switch plate 70. The means for urging 76 together the mating surfaces 70a and 75a of the base plate 70 and clamping plate 75 may comprise screws, clamping jaws or springs or the like. Most preferably the urging means 76 comprises at least one screw 76 passing through the clamping member 75 and into a screw hole 77 in the upper surface 70a of the base plate 70.

One end 121 of an actuator 12 is placed between the mating surfaces 70a and 75a of the base and clamping plates 70 and 75. The mating surfaces 70a and 75a are then urged towards each other with the screw 76 to rigidly hold the end 121 of the actuator 12 in place between the base and clamping plates 70 and 75 with the opposite end 122 of the actuator 12 free to be moved by a mechanical impulse applied manually or preferably by a deflector assembly 72.

Referring now to FIG. 7: In the preferred embodiment of the invention the surfaces 70a and 75a of the base and clamping plate 70 and 75 are designed to best distribute pressure evenly along the end 121 of the actuator therebetween. To this end the upper surface 70a of the base plate 70 contacting the end 121 of the actuator is preferably substantially flat and lower surface 75a of the clamping member 75 preferably has a recess 74 therein which accommodates insertion of the actuator end 121 therein. Preferably the depth of the recess 74 is equal to half the thickness of the

11

actuator substrate 64, but may be as deep as the substrate thickness. Thus, the end 121 of the actuator 12 may be placed between the recess 74 and the upper surface 70a of the base plate 70 and secured therebetween by the screw 76. Alternatively, either or both of the mating surfaces 70a and 75a of the base and clamping plates 70 and 75 may have a recess therein to accommodate insertion and retention of the end 121 of the actuator 12 therebetween. The portion of the bottom surface 75a of the clamping member 75 beyond the recess 74 has no contact with the actuator 12, and is that portion through which the screw 76 passes. This portion of the bottom surface 75a may contact the upper surface 70a of the base plate 70, but most preferably there is a small gap (equal to the difference of the substrate thickness and the recess depth) between the lower surface 75a of the clamping member 75 and the top surface 70a of the base plate 70 when the actuator 12 is inserted therebetween. In yet another embodiment of the invention, the mating surfaces 70a and 75a of the base and clamping plates 70 and 75 may be adhesively bonded together (rather than screwed) with the end 121 of the actuator 12 sandwiched therebetween. In yet another alternative embodiment of the device, the clamping member 75 and base plate 70 may comprise a single molded structure having a central slot into which may be inserted one end 121 of the actuator 12.

The clamping assembly 75 holds the actuator 12 in place in its relaxed, i.e., undeformed state above the base plate 70 with the free end 122 of the actuator 12 in close proximity to a deflector 72 assembly. More specifically, the actuator 12 is preferably clamped between the mating surfaces 70a and 75a of the base and clamping plates 70 and 75 with the convex face 12a of the actuator 12 facing the base plate 70. Since the actuator 12 in its relaxed state is arcuate, the convex face 12a of the actuator 12 curves away from the upper surface 70a of the base plate 70 while approaching the free end 122 of the actuator 12. Mechanical force may then be applied to the free end 122 of the actuator 12 in order to deform the electroactive element 67 to develop an electrical signal.

Because of the composite, multi-layer construction of the actuator 12 it is important to ensure that the clamping member 75 not only holds the actuator 12 rigidly in place, but also that the actuator 12 is not damaged by the clamping member 75. In other words, the actuator 12, and more specifically the ceramic layer 67, should not be damaged by the clamping action of the clamping member 75 in a static mode, but especially in the dynamic state when applying a mechanical impulse to the actuator 12 with the plunger 72. For example, referring to FIG. 6, when a mechanical impulse is applied to the actuator 12 in the direction of arrow 81, the bottom corner of the ceramic (at point C) contacts the base plate 70 and is further pushed into the base plate, which may crack or otherwise damage the ceramic layer 67.

Referring again to FIG. 7: It has been found that the tolerances between the mating surfaces 75a and 70a of the clamping and base plates 75 and 70 are very narrow. It has also been found that application of a downward force (as indicated by arrow 81) to the free end 122 of the actuator 12 would cause the ceramic element 67 of the actuator 12 to contact the upper surface 70a of the base plate 70, thereby making more likely damage to the ceramic 67. Therefore, in the preferred embodiment of the invention, the switch plate 70 has a recessed area 80 in its upper surface 70a which not only protects the electroactive element 67 from damage but also provides electrical contact to the convex face 12a of the actuator 12 so that the electrical signal developed by the actuator 12 may be applied to downstream circuit elements.

12

As can be seen in FIG. 7, one end 121 of the actuator is placed between the surfaces 75a and 70a of the clamping and base plates 75 and 70 such that only the substrate 64 contacts both surface 75a and 70a. The clamping plate 75 preferably contacts the concave surface 12b of the actuator 12 along the substrate 64 up to approximately the edge of the ceramic layer 67 on the opposite face 12a of the actuator 12. The clamping member may however extend along the convex face 12c further than the edge C of the ceramic layer 67 in order to apply greater or more even pressure to the actuator surfaces 12a and 12c between the clamping member 75 and base plate 70. The ceramic layer 67 which extends above the surface of the substrate 64 on the convex face 12a extends into the recessed area 80 of the switch plate 70. This prevents the ceramic layer 67 from contacting the upper surface 70a of the base plate 70, thereby reducing potential for damage to the ceramic layer 67.

The recess 80 is designed not only to prevent damage to the ceramic layer 67, but also to provide a surface along which electrical contact can be maintained with the electrode 68 on the convex face of the actuator 12. The recess 80 extends into the base plate 70 and has a variable depth, preferably being angled to accommodate the angle at which the convex face 12a of the actuator 12 rises from the recess 80 and above the top surface 70a of the base plate 70. More specifically, the recess 80 preferably has a deep end 81 and a shallow end 82 with its maximum depth at the deep end 81 beneath the clamping member 75 and substrate 12 just before where the ceramic layer 67 extends into the recess 80 at point C. The recess 80 then becomes shallower in the direction approaching the free end 122 of the actuator 12 until it reaches its minimum depth at the shallow end 82.

The recess 80 preferably contains a layer of rubber 85 along its lower surface which helps prevent the ceramic layer 67 from being damaged when the actuator 12 is deformed and the lower edge C of the ceramic layer 67 is pushed into the recess 80. Preferably the rubber layer 85 is of substantially uniform thickness along its length, the thickness of the rubber layer 85 being substantially equal to the depth of the recess 80 at the shallow end 82. The length of the rubber layer 85 is preferably slightly shorter than the length of the recess 80 to accommodate the deformation of the rubber layer 85 when the actuator 12 is pushed into the recess and rubber layer 85.

The rubber layer 85 preferably has a flexible electrode layer 90 overlying it to facilitate electrical contact with the aluminum layer 68 on the ceramic layer 67 on the convex face 12a of the actuator 12. More preferably, the electrode layer 90 comprises a layer of copper overlaying a layer of KAPTON film, as manufactured by E.I. du Pont de Nemours and Company, bonded to the rubber layer 85 with a layer of adhesive, preferably CIBA adhesive. The electrode layer 90 preferably extends completely across the rubber layer 85 from the deep end 81 to the shallow end 82 of the recess 80 and continues for a short distance on the top surface 70a of the base plate 70 beyond the recess 80.

In the preferred embodiment of the invention, the end 121 of the actuator 12 is not only secured between the clamping plate 75 and the base plate 70, but the aluminum electrode layer 68 covering the ceramic layer 67 of the actuator 12 is in constant contact with the electrode layer 90 in the recess 80 at all times, regardless of the position of the actuator 12 in its complete range of motion. To this end, the depth of the recess 80 (from the top surface 70a to the electrode 90) is at least equal to a preferably slightly less than the thickness of the laminate layers (adhesive layers 66, ceramic layer 67 and prestress layer 68) extending into the recess 80.

An assembly was built having the following illustrative dimensions. The actuator comprised a 1.59 by 1.79 inch spring steel substrate that was 8 mils thick. A 1-1.5 mil thick layer of adhesive having a nickel dust filler in a 1.51 inch square was placed one end of the substrate 0.02 inch from three sides of the substrate (leaving a 0.25 inch tab on one end **121** of the actuator). An 8-mil thick layer of PZT-5A in a 1.5 inch square was centered on the adhesive layer. A 1-mil thick layer of adhesive (with no metal filler) was placed in a 1.47 inch square centered on the PZT layer. Finally, a 1-mil thick layer of aluminum in a 1.46 inch square was centered on the adhesive layer. The tab **121** of the actuator was placed in a recess in a clamping block **76** having a length of 0.375 inch and a depth of 4 mils. The base plate **70** had a 0.26 in long recess **80** where the deep end **81** of the recess had a depth of 20 mils and tapered evenly to a depth of 15 mils at the shallow end **82** of the recess **80**. A rubber layer **85** having a thickness of 15 mils and a length of 0.24 inches was placed in the recess **80**. An electrode layer of 1 mil copper foil overlying 1 mil KAPTON tape was adhered to the rubber layer and extended beyond the recess 1.115 inches. The clamping member **75** was secured to the base plate **70** with a screw **76** and the aluminum second prestress layer of the actuator **12** contacted the electrode **90** in the recess **80** substantially tangentially (nearly parallel) to the angle the actuator **12** thereby maximizing the surface area of the electrical contact between the two.

As shown in FIG. 7, in an alternate embodiment of the invention, a weight **95** may be attached to the free end **122** of the actuator **12**. The addition of the mass **95** to the free end **122** of the actuator **12**, decreases the amount of damping of the oscillation and thereby increases the duration of oscillation of the actuator **12** when it was deflected and released. By having a longer duration and higher overall amplitude oscillation, the actuator **12** is capable of developing more electrical energy from its oscillation than an actuator **12** having no additional mass at its free end **122**.

Referring to FIGS. 6 and 7: As mentioned above, it is desirable to generate an electrical signal by deforming the actuator **12**. Deformation of the actuator **12** may be accomplished by any suitable means such as manually or by mechanical deflection means such as a plunger, lever or the like. In FIGS. 6 and 7 a simple deflector **72** is mounted to the base plate **70** in proximity to the free end **122** of the actuator **12**. This deflector assembly **72** includes a lever **86** having first and second ends **87** and **88**. The lever is pivotably mounted between the two ends **87** and **88** to a fulcrum **89**. By exerting a force on the first end **87** of the lever **86** in the direction of arrow **91**, the lever pivots about the fulcrum **89** and applies a mechanical impulse in the direction of arrow **81** to the free end **122** of the actuator **12**. Alternatively, the lever **86** may be moved opposite the direction of arrow **91** and the actuator **12** may thus be deflected in the direction opposite arrow **81**.

Referring now to FIGS. 13 and 14a-c: FIGS. 13 and 14a-c show the preferred embodiment of a casing with a deflector assembly **72** and containing the actuator **12**. The base plate **70** forms the base of a casing **200**, which encloses the actuator **12**. On each side of the casing **200** is a wall **201**, **202**, **203** and **204** which extends perpendicularly from the top surface **70a** of the base plate **70**. On one end of the casing **200** is mounted a deflector assembly **72**. The plunger has an interior surface **172b** and an exterior surface **172a**, as well as a free end **173** and a mounted end **174**. More specifically, the plunger **172** is pivotably mounted on one end **174** to a wall **201** of the casing **200**. The free end **173** of the plunger **172** has a ridge **173a** thereon which engages a lip **202a** on the

opposite wall **202** of the casing. Preferably the free end **173** of the plunger **172** is spring loaded so that the ridge **173a** is constantly urged towards the lip **202a**. To this end, there is a preferably a spring **150** held in compression between the top surface **70a** of the base plate **70** and the ridge **173a** or interior surface of the plunger **172b**. This provides for device wherein an actuator **12** mounted on a base plate **70** is contained within a casing **200** formed by the base plate **70** and four walls **201**, **202**, **203** and **204** as well as a plunger **172** pivotably mounted opposite the base plate **70** on a wall **201** of the casing **200**. Because the plunger is pivotably mounted, placing pressure (in the direction of arrow **180** on the exterior surface **172a** of the plunger **172** makes it pivot about the hinge **175** toward the top surface **70a** of the base plate **70**. Because the plunger is pivotably mounted and spring loaded, releasing pressure from the exterior surface **172a** of the plunger **172** makes it pivot about the hinge **175** away the top surface of the base plate **70** until the ridge **173a** catches on the lip **202a**.

Within the casing **200** is a mounted quick release mechanism **180** comprising a spring loaded rocker arm **185** on the interior surface **172b** of the plunger **172** which works in conjunction with a release pin **186** mounted on the top surface **70** of the base plate **70**. The quick release mechanism **180** is designed to deflect and then quickly release the free end **122** of the actuator **12** in order to allow it to vibrate between positions **291** and **292**. The quick release mechanism **180** is also designed not to interfere with the vibration of the actuator **12** as well as to return to a neutral position for follow-on deflections of the actuator **12**.

Referring to FIGS. 14a-c: The rocker arm **185** is pivotably attached to the interior surface **172b** of the plunger **172** above the free end **122** of the actuator **12**. More specifically, the rocker arm **185** is pivotably attached in such a way that it has a neutral position from which it may pivot away from the clamped end **121** of the actuator, but will not pivot towards the clamped end **121** of the actuator **12** from that neutral position. In other words a rotational stop **183** forms part of the quick release mechanism **180** and its placement prevents the rocker arm from pivoting beyond the neutral position at the stop **183**. The rocker arm **185** is preferably spring loaded in order to keep the rocker arm **185** in its neutral position when not being deflected. To this end a spring **187** in compression is placed on the side of the rocker arm **185** opposite the stop **183**, between the rocker arm **185** and a spring stop **188**.

Inside the casing **200** is also a release pin **186** which is located on the top surface **70a** of the base plate **70**. The release pin **186** is located in a position just beyond the free end **122** of the actuator **12** in its deflected position, but not beyond the rocker arm **185**. In other words, when the plunger **172** is depressed toward the release pin **186**, depressing with it the actuator **12** from position **291** to position **292**, the release pin **186** will contact the rocker arm **185** but not the actuator **12**. As the rocker arm **185** (and actuator **12**) are depressed further, the release pin **186** pushes the rocker arm **185** away, making the rocker arm **185** pivot away from the clamped end **121** of the actuator **12**. The rocker arm **185** pivots until the edge **122** of the actuator **12** is no longer held by the rocker arm **185** in position **292**, at which point the edge **122** of the actuator **12** is released and springs back to its undeformed state, thereby oscillating between positions **291** and **292**.

When pressure from the plunger **172** is released, the plunger **172** returns to its undeflected position (with the ridge **173a** against the lip **202a**) by virtue of the restoring force of the spring **150**. Also when the pressure from the

15

plunger 172 is released, and the plunger 172 returns to its undeflected position, the rocker arm 185 also returns to its undeflected position (above the actuator 12 against the stop 183) by virtue of the restoring force of the spring 187. Lastly, the actuator 12 also returns to its undeflected state in position 291 after its oscillations between positions 291 and 292 have ceased.

Referring now to FIGS. 14 and 16a-d: FIGS. 14 and 16a-d show an alternate embodiment of a deflector assembly 72 mounted to a casing 200 that contains the actuator 12. The base plate 70 forms the base of a casing 200, which encloses the actuator 12. On each side of the casing 200 is a wall 201, 202, 203 and 204 which extends perpendicularly from the top surface 70a of the base plate 70. Attached to the top of the walls of the casing 200 (opposite the base plate 70) is a face plate 220 to which is mounted a slide mechanism 230 that acts as a deflector assembly 72. The face plate 220 has an interior surface 220a and an exterior surface 220b and a channel 240 extending through substantially the center of the face plate 220. The channel 240 has a first end 241 and a second end 242 and extends substantially linearly along an axis L perpendicular to the first and second walls 201 and 202 of the casing 200. In other words, the first end 241 of the channel 240 through the face plate 220 is in proximity to the first wall 201 of the casing 200 and the second end 242 of the channel 240 through the face plate 220 is in proximity to the second wall 202 of the casing 200. The second end of the channel 240 preferably extends further towards the second wall 202 of the casing than does the free end 122 of the actuator 12.

The channel 240 is adapted to slidably retain a spring loaded paddle 250. Preferably, the paddle has first and second ends 251 and 252 respectively and a central pin 255. The channel in the face plate 220 allows the paddle to extend through the face plate 220, while also slidably retaining the central pin 255 in the channel 240. More specifically, the paddle 250 extends through the face plate 220 by means of the channel 240, along which the paddle may be slid in a direction parallel to the channels' axis L, i.e., from the clamped end 121 to the free end 122 of the actuator 12 and back. The first end 251 of the paddle 250 is located above the exterior surface 220b of the face plate 220 and the second end 252 of the paddle 250 is located within the casing 200 above the actuator 12. The paddle 250 is retained in the described position by means of the pin 255 which is retained in the channel 240. Thus, the width of the channel 240 at the exterior surface 220b is sufficient for the paddle upper portion 251 to pass through, as is the width of the channel 240 at the interior surface 220a is sufficient for the paddle lower portion 252 to pass through. The width and height of the channel 240 within the face plate 220 (between the interior and exterior surfaces 220a and 220b) is sufficient to accommodate the width and height of the central pin 255, which is wider than the width of the paddle upper and lower portions 251 and 252.

The first end 251 of the paddle 250 preferably extends a distance above the exterior surface 220b of the face plate 220 enough to be grasped manually. The second end 252 of the paddle 250 preferably extends into the casing 200 a distance above the actuator 12 such that the paddle 250 does not contact the clamping member 75 and/or clamped end 121 of the actuator 12, but also far enough that it may contact and deflect the free end 122 of the actuator 12. The paddle 250 is also preferably hinged at the second end 252 (within the casing 200 or the channel 240 at or in proximity to the central pin 255) in a manner that allows the second end 252 to pivot about the hinge or central pin 255 when

16

travelling in one direction but not the other. Preferably, the second end 252 of the paddle 250 is hinged in a way that it may pivot when the paddle 250 is travelling toward the first wall 201 of the casing 200 but not pivot when travelling towards the second wall 202 of the casing 200.

Preferably the paddle 250 is also spring loaded so that the paddle is constantly urged along the channel 240 towards the first wall 201 of the casing 200. To that end, there is a spring 260 held between the paddle and the first wall 201 or second wall 202 of the casing 200 or most preferably the spring 260 held between the paddle 250 and the first or second end 241 or 242 of the channel 240. In order to urge the paddle toward the first wall 201 the spring 260 is either held in tension between the paddle 250 and the first end 241 of the channel 240, or most preferably the spring 260 is held in compression between the paddle 250 and the second end 242 of the channel 240.

This provides for device wherein an actuator 12 mounted on a base plate 70 is contained within a casing 200 formed by the base plate 70, four walls 201, 202, 203 and 204 and a face plate opposite the base plate 70. Because the paddle 250 is slidably mounted, placing pressure (in the direction of arrow 281) on the first end of the paddle makes it slide along the channel 240 toward the second wall 202 of the casing 200. Because the paddle 250 is slidably mounted and spring loaded, releasing pressure from the paddle 250 makes it return along the channel 240 toward the first wall 201 of the casing 200 until it comes to rest against the first end 241 of the channel 240.

Referring to FIGS. 16a-d: The paddle upper portion 251 is pivotably attached to the paddle lower portion 252 below the interior surface 220a of the face plate 220 (within the casing 200) above the actuator 12. More specifically, the paddle lower portion 252 is pivotably attached in such a way that it has a neutral position from which it may pivot away from the clamped end 121 of the actuator, but will not pivot towards the clamped end 121 of the actuator 12 from that neutral position. In other words the shape of the paddle 250 prevents the lower portion 252 from pivoting beyond the neutral position.

In operation, when the paddle 250 is moved (in the direction of arrow 281) toward the second end 242 of the channel 240, the paddle lower portion 252 contacts concave face 12c of the actuator 12 and commences to deflect the actuator free end 122 (away from position 291). As the paddle 250 continues to move in the direction of arrow 281, the paddle lower portion 252 depresses the free end 122 of the actuator 12 to its maximum deflection at position 292 when the free end 122 is directly beneath the paddle lower portion 252. When the paddle moves further from this point in the direction of arrow 281, the free end 122 of the actuator 12 is abruptly released from the applied deflection of the paddle lower portion 252. Upon release, the edge 122 of the actuator 12 springs back to its undeformed state at position 291, thereby oscillating between positions 291 and 292. Upon release of pressure (in the direction of arrow 281) from the paddle 250, the paddle then travels in the direction of arrow 282, by virtue of the restoring force of the spring 260. As the paddle 250 returns towards its undeflected position (towards the first end 241 of the channel 240), the free end 122 of the actuator 12 in position 291 applies pressure against the lower portion 252 of the paddle 250. In response to the pressure being applied to the paddle lower portion opposite the direction of travel of the upper portion 251, the lower portion 252 pivots about the hinged central pin 255 of the paddle. After the paddle lower portion 252 has traveled in the direction of arrow 282 beyond the free end 122 of the

actuator, the lower portion **252** returns to its undeflected (unbent) state. The pivoting of the paddle lower portion **252** allows the paddle **250** to return to its neutral undeflected position at the first end **241** of the channel **240**.

When the end **122** of the actuator **12** is deflected and then released (either manually or using a deflector assembly **72** such as in FIGS. **6-7**, or **13-16**), the end **122** of the actuator **12**, much like a diving board, oscillates back and forth between positions **291** and **292**. This is because the substrate and prestress layer **64** and **68** to which the ceramic **67** is bonded exert a compressive force on the ceramic **67** thereby providing a restoring force. Therefore, the actuator **12** has a coefficient of elasticity or spring constant that causes the actuator **12** to return to its undeformed neutral state at position **291**. The oscillation of the actuator **12** has the waveform of a damped harmonic oscillation, as is illustrated in FIG. **10a**. In other words, the amplitude of the oscillation of the free end **122** of the actuator **12** is at its maximum immediately following (within a few oscillations after) the release of the mechanical impulse from the free end **122** of the actuator **12**. As the actuator **12** continues to vibrate, the amplitude gradually decreases over time (approximately exponentially) until the actuator **12** is at rest in its neutral position.

The applied force, whether by manual or other mechanical deflection means **72** causes the piezoelectric actuator **12** to deform and by virtue of the piezoelectric effect, the deformation of the piezoelectric element **67** generates an instantaneous voltage between the faces **12a** and **12c** of the actuator **12**, which produces an electrical signal. Furthermore, when the force is removed from the piezoelectric actuator **12**, the actuator oscillates between positions **291** and **292** until it gradually returns to its original shape. As the actuator **12** oscillates, the ceramic layer **67** strains, becoming alternately more compressed and less compressed. The polarity of the voltage produced by the ceramic layer **67** depends on the direction of the strain, and therefore, the polarity of the voltage generated in compression is opposite to the polarity of the voltage generated in tension. Therefore, as the actuator **12** oscillates, the voltage produced by the ceramic element **67** oscillates between a positive and negative voltage for a duration of time. The duration of the oscillation, and therefore the duration of the oscillating electrical signal produced, is preferably in the range of 100-250 milliseconds, depending on the shape, mounting and amount of force applied to the actuator **12**.

The electrical signal generated by the actuator **12** is applied to downstream circuit elements via wires **14** connected to the actuator **12**. More specifically, a first wire **14** is connected to the electrode **90** which extends into the recess **80** and contacts the electrode **68** on the convex face **12a** of the actuator **12**. Preferably the wire **14** is connected to the electrode **90** outside of the recess close to the end of the base plate **70** opposite the end having the clamping member **75**. A second wire **14** is connected directly to the first prestress layer **64**, i.e., the substrate **64** which acts as an electrode on the concave face **12c** of the actuator **12**.

Referring to FIG. **8**, the actuator **12** is connected to circuit components downstream in order to generate an RF signal for actuation of a switch initiator. These circuit components include a rectifier **31**, a voltage regulator **U2**, an encoder **40** (preferably comprising a peripheral interface controller (PIC) chip) as well as an RF generator **50** and antenna **60**. FIG. **10b** shows the waveform of the electrical signal of FIG. **10a** after it has been rectified. FIG. **1c** shows the waveform

of the rectified electrical signal of FIG. **10b** after it has been regulated to a substantially uniform voltage, preferably 3.3 VDC.

Referring now to FIG. **9**: The actuator **12** is first connected to a rectifier **31**. Preferably the rectifier **31** comprises a bridge rectifier **31** comprising four diodes **D1**, **D2**, **D3** and **D4** arranged to only allow positive voltages to pass. The first two diodes **D1** and **D2** are connected in series, i.e., the anode of **D1** connected to the cathode of **D2**. The second two diodes **D3** and **D4** are connected in series, i.e., the anode of **D3** connected to the cathode of **D4**. The anodes of diodes **D2** and **D4** are connected, and the cathodes of diodes **D1** and **D3** are connected, thereby forming a bridge rectifier. The rectifier is positively biased toward the **D2-D4** junction and negatively biased toward the **D1-D3** junction. One of the wires **14** of the actuator **12** is electrically connected between the junction of diodes **D1** and **D2**, whereas the other wire **14** (connected to the opposite face of the actuator **12**) is connected to the junction of diodes **D3** and **D4**. The junction of diodes **D1** and **D3** are connected to ground. A capacitor **C11** is preferably connected on one side to the **D2-D4** junction and on the other side of the capacitor **C11** to the **D1-D3** junction in order to isolate the voltages at each side of the rectifier from each other. Therefore, any negative voltages applied to the **D1-D2** junction or the **D3-D4** junction will pass through diodes **D1** or **D3** respectively to ground. Positive voltages applied to the **D1-D2** junction or the **D3-D4** junction will pass through diodes **D2** or **D4** respectively to the **D2-D4** junction. The rectified waveform is shown in FIG. **10b**.

The circuit also comprises a voltage regulator **U2**, which controls magnitude of the input electrical signal downstream of the rectifier **31**. The rectifier **31** is electrically connected to a voltage regulator **U2** with the **D2-D4** junction connected to the **Vin** pin of the voltage regulator **U2** and with the **D1-D3** junction connected to ground and the ground pin of the voltage regulator **U2**. The voltage regulator **U2** comprises for example a **LT1121** chip voltage regulator **U2** with a 3.3 volts DC output. The output voltage waveform is shown in FIG. **10c** and comprises a substantially uniform voltage signal of 3.3 volts having a duration of approximately 100-250 milliseconds, depending on the load applied to the actuator **12**. The regulated waveform is shown in FIG. **10b**. The output voltage signal from the voltage regulator (at the **Vout** pin) may then be transmitted via another conductor to the relay switch **290**, in order to change the position of a relay switch **290** from one position to another. Preferably however, the output voltage is connected through an encoder **40** to an RF generation section **50** of the circuit.

Referring again to FIGS. **8** and **9**: The output of the voltage regulator **U2** is preferably used to power an encoder **40** or tone generator comprising a peripheral interface controller (PIC) microcontroller that generates a pulsed tone. This pulsed tone modulates an RF generator section **50** which radiates an RF signal using a tuned loop antenna **60**. The signal radiated by the loop antenna is intercepted by an RF receiver **270** and a decoder **280** which generates a relay pulse to activate the relay **290**.

The output of the voltage regulator **U2** is connected to a PIC microcontroller, which acts as an encoder **40** for the electrical output signal of the regulator **U2**. More specifically, the output conductor for the output voltage signal (nominally 3.3 volts) is connected to the input pin of the programmable encoder **40**. Types of register-based PIC microcontrollers include the eight-pin **PIC12C5XX** and **PIC12C67x**, baseline **PIC16C5X**, midrange **PIC16CXX** and the high-end **PIC17CXX/PIC18CXX**. These controllers

employ a modified Harvard, RISC architecture that support various-width instruction words. The datapaths are 8 bits wide, and the instruction widths are 12 bits wide for the PIC16C5X/PIC12C5XX, 14 bits wide for the PIC12C67X/PIC16CXX, and 16 bits wide for the PIC17CXX/PIC18CXX. PICMICROS are available with one-time programmable EPROM, flash and mask ROM. The PIC17CXX/PIC18CXX support external memory. The encoder 40 comprises for example a PIC model 12C671. The PIC12C6XX products feature a 14-bit instruction set, small package footprints, low operating voltage of 2.5 volts, interrupts handling, internal oscillator, on-board EEPROM data memory and a deeper stack. The PIC12C671 is a CMOS microcontroller programmable with 35 single word instructions and contains 1024×14 words of program memory, and 128 bytes of user RAM with 10 MHz maximum speed. The PIC12C671 features an 8-level deep hardware stack, 2 digital timers (8-bit TMRO and a Watchdog timer), and a four-channel, 8-bit A/D converter.

The output of the PIC may include square, sine or saw waves or any of a variety of other programmable waveforms. Typically, the output of the encoder 40 is a series of binary square waveforms (pulses) oscillating between 0 and a positive voltage, preferably +3.3 VDC. The duration of each pulse (pulse width) is determined by the programming of the encoder 40 and the duration of the complete waveform is determined by the duration of output voltage pulse of the voltage regulator U2. A capacitor C5 is preferably be connected on one end to the output of the voltage regulator U2, and on the other end to ground to act as a filter between the voltage regulator U2 and the encoder 40.

Thus, the use of an IC as a tone generator or encoder 40 allows the encoder 40 to be programmed with a variety of values. The encoder 40 is capable of generating one of many unique encoded signals by simply varying the programming for the output of the encoder 40. More specifically, the encoder 40 can generate one of a billion or more possible codes. It is also possible and desirable to have more than one encoder 40 included in the circuit in order to generate more than one code from one actuator or transmitter. Alternately, any combination of multiple actuators and multiple pulse modification subcircuits may be used together to generate a variety of unique encoded signals. Alternately the encoder 40 may comprise one or more inverters forming a series circuit with a resistor and capacitor, the output of which is a square wave having a frequency determined by the RC constant of the encoder 40.

The DC output of the voltage regulator U2 and the coded output of the encoder 40 are connected to an RF generator 50. A capacitor C6 may preferably be connected on one end to the output of the encoder 40, and on the other end to ground to act as a filter between the encoder 40 and the RF generator 50. The RF generator 50 consists of tank circuit connected to the encoder 40 and voltage regulator U2 through both a bipolar junction transistor (BJT) Q1 and an RF choke. More specifically, the tank circuit consists of a resonant circuit comprising an inductor L2 and a capacitor C8 connected to each other at each of their respective ends (in parallel). Either the capacitor C8 or the inductor L2 or both may be tunable in order to adjust the frequency of the tank circuit. An inductor L1 acts as an RF choke, with one end of the inductor L1 connected to the output of the voltage regulator U2 and the opposite end of the inductor L1 connected to a first junction of the L2-C8 tank circuit. Preferably, the RF choke inductor L1 is an inductor with a diameter of approximately 0.125 inches and turns on the order of thirty and is connected on a loop of the tank circuit

inductor L2. The second and opposite junction of the L2-C8 tank circuit is connected to the collector of BJT Q1. The base of the BJT Q1 is also connected through resistor R2 to the output side of the encoder 40. A capacitor C7 is connected to the base of a BJT Q1 and to the first junction of the tank circuit. Another capacitor C9 is connected in parallel with the collector and emitter of the BJT Q1. This capacitor C9 improves the feedback characteristics of the tank circuit. The emitter of the BJT Q1 is connected through a resistor R3 to ground. The emitter of the BJT Q1 is also connected to ground through capacitor C10 which is in parallel with the resistor R3. The capacitor C10 in parallel with the resistor R4 provides a more stable conduction path from the emitter at high frequencies.

Referring now to FIGS. 11 and 12: The RF generator 50 works in conjunction with a tuned loop antenna 60. In the preferred embodiment, the inductor L2 of the tank circuit serves as the loop antenna 60. More preferably, the inductor/loop antenna L2 comprises a single rectangular loop of copper wire having an additional smaller loop or jumper 61 connected to the rectangular loop L2. Adjustment of the shape and angle of the smaller loop 61 relative to the rectangular loop L2 is used to increase or decrease the apparent diameter of the inductor L2 and thus tunes the RF transmission frequency of the RF generator 50. In an alternate embodiment, a separate tuned antenna may be connected to the second junction of the tank circuit.

In operation: The positive voltage output from the voltage regulator U2 is connected the encoder 40 and the RF choke inductor L1. The voltage drives the encoder 40 to generate a coded square wave output, which is connected to the base of the BJT Q1 through resistor R2. When the coded square wave voltage is zero, the base of the BJT Q1 remains de-energized, and current does not flow through the inductor L1. When the coded square wave voltage is positive, the base of the BJT Q1 is energized through resistor R2. With the base of the BJT Q1 energized, current is allowed to flow across the base from the collector to the emitter and current is also allowed to flow across the inductor L1. When the square wave returns to a zero voltage, the base of the BJT Q1 is again de-energized.

When current flows across the choke inductor L1, the tank circuit capacitor C8 charges. Once the tank circuit capacitor C8 is charged, the tank circuit begins to resonate at the frequency determined by the circuit's LC constant. For example, a tank circuit having a 7 picofarad capacitor and an inductor L2 having a single rectangular loop measuring 0.7 inch by 0.3 inch, the resonant frequency of the tank circuit is 310 MHz. The choke inductor L1 prevents RF leakage into upstream components of the circuit (the PIC) because changing the magnetic field of the choke inductor L1 produces an electric field opposing upstream current flow from the tank circuit. To produce an RF signal, charges have to oscillate with frequencies in the RF range. Thus, the charges oscillating in the tank circuit inductor/tuned loop antenna L2 produce an RF signal of preferably 310 MHz. As the square wave output of the inverter turns the BJT Q1 on and off, the signal generated from the loop antenna 60 comprises a pulsed RF signal having a duration of 100-250 milliseconds and a pulse width determined by the encoder 40, (typically of the order of 0.1 to 5.0 milliseconds thus producing 20 to 2500 pulses at an RF frequency of approximately 310 MHz. The RF generator section 50 is tunable to multiple frequencies. Therefore, not only is the transmitter capable of a great number of unique codes, it is also capable of generating each of these codes at a different frequency,

which greatly increases the number of possible combinations of unique frequency-code signals.

The RF generator **50** and antenna **60** work in conjunction with an RF receiver **270**. More specifically, an RF receiver **270** in proximity to the RF transmitter **60** (within 300 feet) can receive the pulsed RF signal transmitted by the RF generator **50**. The RF receiver **270** comprises a receiving antenna **270** for intercepting the pulsed RF signal (tone). The tone generates a pulsed electrical signal in the receiving antenna **270** that is input to a microprocessor chip that acts as a decoder **280**. The decoder **280** filters out all signals except for the RF signal it is programmed to receive, e.g., the signal generated by the RF generator **50**. An external power source is also connected to the microprocessor chip/decoder **280**. In response to the intercepted tone from the RF generator **50**, the decoder chip produces a pulsed electrical signal. The external power source connected to the decoder **280** augments the pulsed voltage output signal developed by the chip. This augmented (e.g., 120VAC) voltage pulse is then applied to a conventional relay **290** for changing the position of a switch within the relay. Changing the relay switch position is then used to turn an electrical device with a bipolar switch on or off, or toggle between the several positions of a multiple position switch. Zero voltage switching elements may be added to ensure the relay **290** activates only once for each depression and recovery cycle of the flextensional transducer element **12**.

Switch Initiator System with Trainable Receiver

Several different RF transmitters may be used that generate different tones for controlling relays that are tuned to receive that tone. In another embodiment, digitized RF signals may be coded and programmable (as with a garage door opener) to only activate a relay that is coded with that digitized RF signal. In other words, the RF transmitter is capable of generating at least one tone, but is preferably capable of generating multiple tones. Most preferably, each transmitter is programmed with one or more unique coded signals. This is easily done, since programmable ICs for generating the tone can have over 2^{30} possible unique signal codes which is the equivalent of over 1 billion codes. Most preferably the invention comprises a system of multiple transmitters and one or more receivers for actuating building lights, appliances, security systems and the like. In this system for remote control of these devices, an extremely large number of codes are available for the transmitters for operating the lights, appliances and/or systems and each transmitter has at least one unique, permanent and nonuser changeable code. The receiver and controller module at the lights, appliances and/or systems is capable of storing and remembering a number of different codes corresponding to different transmitters such that the controller can be programmed so as to actuated by more than one transmitted code, thus allowing two or more transmitters to actuate the same light, appliance and/or system.

The remote control system includes a receiver/controller for learning a unique code of a remote transmitter to cause the performance of a function associated with the system, light or appliance with which the receiver/controller module is associated. The remote control system is advantageously used, in one embodiment, for interior or exterior lighting, household appliances or security system. Preferably, a plurality of transmitters is provided wherein each transmitter has at least one unique and permanent non-user changeable code and wherein the receiver can be placed into a program mode wherein it will receive and store two or more codes corresponding to two or more different transmitters. The number of codes which can be stored in transmitters can be

extremely high as, for example, greater than one billion codes. The receiver has a decoder module therein which is capable of learning many different transmitted codes, which eliminates code switches in the receiver and also provides for multiple transmitters for actuating the light or appliance. Thus, the invention makes it possible to eliminate the requirements for code selection switches in the transmitters and receivers.

Referring to FIG. **8**: The receiver module **101** includes a suitable antenna **270** for receiving radio frequency transmissions from one or more transmitters **126** and **128** and supplies an input to a decoder **280** which provides an output to a microprocessor unit **244**. The microprocessor unit **244** is connected to a relay device **290** or controller which switches the light or appliance between one of two or more operation modes, i.e., on, off, dim, or some other mode of operation. A switch **222** is mounted on a switch unit **219** connected to the receiver and also to the microprocessor **244**. The switch **222** is a two position switch that can be moved between the "operate" and "program" positions to establish operate and program modes.

In the invention, each transmitter, such as transmitters **126** and **128**, has at least one unique code which is determined by the tone generator/encoder **40** contained in the transmitter. The receiver unit **101** is able to memorize and store a number of different transmitter codes which eliminates the need of coding switches in either the transmitter or receiver which are used in the prior art. This also eliminates the requirement that the user match the transmitter and receiver code switches. Preferably, the receiver **101** is capable of receiving many transmitted codes, up to the available amount of memory locations **147** in the microprocessor **144**, for example one hundred or more codes.

When the controller **290** for the light or appliance is initially installed, the switch **222** is moved to the program mode and the first transmitter **126** is energized so that the unique code of the transmitter **126** is transmitted. This is received by the receiver module **101** having an antenna **270** and decoded by the decoder **280** and supplied to the microprocessor unit **244**. The code of the transmitter **126** is then supplied to the memory address storage **247** and stored therein. Then if the switch **222** is moved to the operate mode and the transmitter **126** energized, the receiver **270**, decoder **280** and the microprocessor **244** will compare the received code with the code of the transmitter **126** stored in the first memory location in the memory address storage **247** and since the stored memory address for the transmitter **126** coincides with the transmitted code of the transmitter **126** the microprocessor **244** will energize the controller mechanism **290** for the light or appliance to energize de-energize or otherwise operate the device.

In order to store the code of the second transmitter **128** the switch **222** is moved again to the program mode and the transmitter **128** is energized. This causes the receiver **270** and decoder **280** to decode the transmitted signal and supply it to the microprocessor **244** which then supplies the coded signal of the transmitter **128** to the memory address storage **247** where it is stored in a second address storage location. Then the switch **222** is moved to the operate position and when either of the transmitters **126** and **128** are energized, the receiver **270** decoder **280** and microprocessor **244** will energize the controller mechanism **290** for the light or appliance to energize de-energize or otherwise operate the device. Alternately, the signal from the first transmitter **126** and second transmitter **128** may cause separate and distinct actions to be performed by the controller mechanism **290**.

Thus, the codes of the transmitters **126** and **128** are transmitted and stored in the memory address storage **247** during the program mode after which the system, light or appliance controller **290** will respond to either or both of the transmitters **126** and **128**. Any desired number of transmitters can be programmed to operate the system, light or appliance up to the available memory locations in the memory address storage **247**.

This invention eliminates the requirement that binary switches be set in the transmitter or receiver as is done in systems of the prior art. The invention also allows a controller to respond to a number of different transmitters because the specific codes of a number of the transmitters are stored and retained in the memory address storage **247** of the receiver module **101**.

In yet another more specific embodiment of the invention, each transmitter **126** or **128** contains two or more unique codes for controlling a system, light or appliance. One code corresponds in the microprocessor to the "on" position and another code corresponds in the microprocessor **244** to the "off" position of the controller **290**. Alternately, the codes may correspond to "more" or "less" respectively in order to raise or lower the volume of a sound device or to dim or undim lighting for example. Lastly, the unique codes in a transmitter **126** or **128** may comprise four codes which the microprocessor interprets as "on", "off", "more" and "less" positions of the controller **290**, depending on the desired setup of the switches. Alternatively, a transmitter **126** or **128** may only have two codes, but the microprocessor **244** interprets repeated pushes of "on" or "off" signals respectively to be interpreted as dim up and dim down respectively.

In another embodiment of the invention, receiver modules **101** may be trained to accept the transmitter code(s) in one-step. Basically, the memory **247** in the microprocessor **244** of the receiver modules **101** will have "slots" where codes can be stored. For instance one slot may be for all of the codes that the memory **247** accepts to be turned on, another slot for all the off codes, another all the 30% dimmed codes, etc.

Each transmitter **126** has a certain set of codes. For example one transmitter may have just one code, a "toggle" code, wherein the receiver module **101** knows only to reverse its current state, if it's on, turn off, and if it's off, turn on. Alternatively, a transmitter **126** may have many codes for the complex control of appliances. Each of these codes is "unique". The transmitter **126** sends out its code set in a way in which the receiver **101** knows in which slots to put each code. Also, with the increased and longer electrical signal that can be generated in the transmitter **126**, a single transmission of a code set is achievable even with mechanically produced voltage. As a back-up, if this is not true, and if wireless transmission uses up more electricity than we have available, some sort of temporary wired connection (jumper not shown) between each transmitter and receiver target is possible. Although the disclosed embodiment shows manual or mechanical interaction with the transmitter and receiver to train the receiver, it is yet desirable to put the receiver in reprogram mode with a wireless transmission, for example a "training" code.

In yet another embodiment of the invention, the transmitter **126** may have multiple unique codes and the transmitter randomly selects one of the multitude of possible codes, all of which are programmed into the memory allocation spaces **247** of the microprocessor **244**.

In yet another embodiment of the invention, the transmitter **126** signal need not be manually operated or triggered, but may as easily be operated by any manner of mechanical

force, i.e., the movement of a window, door, safe, foot sensor, etc. and that a burglar alarm sensor might simultaneously send a signal to the security system and a light in the intruded upon room. Likewise, the transmitter **126** may be combined with other apparatus. For example, a transmitter **126** may be located within a garage door opener which can also turn on one or more lights in the house, when the garage door opens.

Furthermore, the transmitters can talk to a central system or repeater which re-transmits the signals by wire or wireless means to lights and appliances. In this manner, one can have one transmitter/receiver set, or many transmitters interacting with many different receivers, some transmitters talking to one or more receivers and some receivers being controlled by one or more transmitters, thus providing a broad system of interacting systems and wireless transmitters. Also, the transmitters and receivers may have the capacity of interfacing with wired communications like SMARTHOME or BLUETOOTH.

While in the preferred embodiment of the invention, the actuation means has been described as from mechanical to electric, it is within the scope of the invention to include batteries in the transmitter to power or supplement the power of the transmitter. For example, rechargeable batteries may be included in the transmitter circuitry and may be recharged through the electromechanical actuators. These rechargeable batteries may thus provide backup power to the transmitter.

It is seen that the present invention allows a receiving system to respond to one of a plurality of transmitters which have different unique codes which can be stored in the receiver during a program mode. Each time the "program mode switch" **222** is moved to the program position, a different storage can be connected so that the new transmitter code would be stored in that address. After all of the address storage capacity have been used additional codes would erase all old codes in the memory address storage before storing a new one.

This invention is safe because it eliminates the need for 120 VAC (220 VAC in Europe) lines to be run to each switch in the house. Instead the higher voltage overhead AC lines are only run to the appliances or lights, and they are actuated through the self-powered switching device and relay switch. The invention also saves on initial and renovation construction costs associated with cutting holes and running the electrical lines to/through each switch and within the walls. The invention is particularly useful in historic structures undergoing preservation, as the walls of the structure need not be destroyed and then rebuilt. The invention is also useful in concrete construction, such as structures using concrete slab and/or stucco construction and eliminate the need to have wiring on the surface of the walls and floors of these structures.

While the above description contains many specificities, these should not be construed as limitations on the scope of the invention, but rather as an exemplification of one preferred embodiment thereof. Many other variations are possible, for example:

In addition to piezoelectric devices, the electroactive elements may comprise magnetostrictive or ferroelectric devices;

Rather than being arcuate in shape, the actuators may normally be flat and still be deformable;

Multiple high deformation piezoelectric actuators may be placed, stacked and/or bonded on top of each other;

Multiple piezoelectric actuators may be placed adjacent each other to form an array.

25

Larger or different shapes of THUNDER elements may also be used to generate higher impulses.

The piezoelectric elements may be flextensional actuators or direct mode piezoelectric actuators.

A bearing material may be disposed between the actuators and the recesses or switch plate in order to reduce friction and wearing of one element against the next or against the frame member of the switch plate.

Other means for applying pressure to the actuator may be used including simple application of manual pressure, rollers, pressure plates, toggles, hinges, knobs, sliders, twisting mechanisms, release latches, spring loaded devices, foot pedals, game consoles, traffic activation and seat activated devices.

We claim:

1. A self-powered switching system, comprising:

a flextensional transducer, said flextensional transducer comprising;

a first electroactive member having opposing first and second electroded major faces;

said first [opposing] *electroded* major face being substantially convex and said second [opposing] *electroded* major face being substantially concave;

a prestress layer bonded to said second *electroded* major face of said first electroactive member;

said prestress layer applying a compressive force to said *first* electroactive member;

said prestress layer having first and second ends adjacent said [concave] *second electroded major* face of said first electroactive member;

wherein

said flextensional transducer is adapted to deform from a first position to a second position upon application of a force to said flextensional transducer; *and*

[and wherein] upon said deformation to said second position, said flextensional transducer is adapted to generate a first voltage potential between said first electroded major face and said second electroded major face;

a mounting member for retaining said first end of said prestress layer;

said mounting member comprising:

a plate adjacent said first end of said prestress layer and said [convex] *first electroded major* face of said flextensional transducer;

[said mounting member comprising] clamping means adjacent said first end of said prestress layer and said [concave] *second electroded major* face of said flextensional transducer;

a recess defining a depressed surface in said plate, said depressed surface substantially conforming to at least a portion of said first electroded major face of said flextensional transducer adjacent said first end of said prestress layer and said first electroded major face of said electroactive member; and

a conductive sheet within said recess, said conductive sheet being in electrical contact with said first electroded major face of said first electroactive member and a first conductor electrically connected to said first electroded major face of said first electroactive member;

pressure application means for application of a force to said second end of said prestress layer, said pressure application means being adapted to apply a force sufficient to deform said flextensional transducer from

26

said first position to said second position, thereby generating said first voltage potential;

[a first conductor electrically connected to said first electroded major face of said first electroactive member;]

a second conductor electrically connected to said second electroded major face of said first electroactive member;

first signal transmission means electrically connected to said first and second conductors;

said first signal transmission means comprising a first radio frequency generator subcircuit connected to an antenna;

signal reception means for receiving a first signal transmitted by said first signal transmission means;

said signal reception means being adapted to generate a second signal in response to said first signal transmitted by said signal transmission means; and

a switch having a first position and a second position;

said switch being in communication with said signal reception means; *and*

said switch being adapted to change between said first position and said second position in response to said second signal.

[2. The switching system according to claim 1:

wherein said mounting member further comprises a recess defining a depressed surface in said plate, said depressed surface substantially conforming to at least a portion of said convex face of said flextensional transducer adjacent said first end of said prestress layer and said major first electroded face of said electroactive member; and

a conductive sheet within said recess, said conductive sheet being in electrical contact with said first electroded major face of said electroactive member and said first conductor.]

3. The switching system according to claim [2] 1:

wherein said mounting member further comprises a flexible material within said recess in said plate, said flexible material being between said depressed surface and said conductive sheet.

4. The switching system according to claim 3, further comprising:

a voltage regulator having an input side and an output side;

said input side of said voltage regulator being electrically connected to said first and second conductors; said output side of said voltage regulator being electrically connected to said signal transmission means.

5. The switching system according to claim 4, further comprising:

a diode having an anode and a cathode connected in parallel with said flextensional *transducer*;

said cathode of said diode being electrically connected to said first conductor and said input side of said voltage regulator;

said anode of said diode being electrically connected to said second conductor and said input side of said voltage regulator;

whereby said diode is connected in parallel with first and second electroded major faces of said first electroactive member.

6. The switching system according to claim 5, wherein said signal transmission means further comprises:

a tone generator subcircuit having an input side and an output side;

27

said input side of said tone generator subcircuit being connected to said output side of said voltage regulator;

said output side of said tone generator subcircuit being connected to said first radio frequency generator subcircuit.

7. The switching system according to claim 6, wherein said tone generator subcircuit comprises:

an oscillator array having an input side and an output side; said input side of said oscillator array being connected to said output side of said voltage regulator; and

a transistor having a grounded emitter and a base connected to said output side of said oscillator array;

and wherein said first radio frequency generator subcircuit comprises a resonant subcircuit having a first and a second junction;

said first junction of said resonant subcircuit being connected to said voltage regulator;

said second junction of said resonant subcircuit being connected to a collector of said transistor.

8. The switching system according to claim 7, wherein said first radio frequency generator subcircuit further comprises:

a radio frequency choke connected in series between said output side of said voltage regulator and said first junction of said resonant subcircuit.

9. The switching device according to claim 8, wherein said resonant subcircuit comprises:

a first capacitor having a first and a second plate; and an inductive loop of a third conductor having first and second ends;

said first plate of said first capacitor being connected to said first end of said third conductor, thereby forming said first junction of said resonant subcircuit;

said second plate of said first capacitor being connected to said second end of said third conductor, thereby forming said second junction of said resonant subcircuit.

10. The switching system according to claim 9, wherein said oscillator array further comprises an inverter array connected between said output side of said voltage regulator and said base of said transistor.

11. The switching system according to claim 10, wherein said radio frequency choke comprises an inductor.

12. The switching system according to claim 11, wherein said resonant subcircuit further comprises:

a tuning jumper comprising a sixth conductor having first and second ends each connected to said third conductor;

said tuning jumper being adapted to pivot at said first and second ends, thereby rotating relative to said third conductor.

13. The switching system according to claim 12, further comprising:

second signal transmission means having a second radio frequency generator subcircuit tunable to a second frequency;

wherein said first radio frequency generator subcircuit is tunable to a first frequency different from said second frequency of said second radio frequency generator subcircuit.

14. The switching device according to claim 13, wherein said first tone generator and said first radio frequency generator subcircuits comprise [a] at least one programmable integrated interface controller circuit.

15. The switching device according to claim 14, wherein said signal reception means further comprises:

28

a first radio signal receiver for intercepting said first signal transmitted by said first radio frequency generator subcircuit and a second signal transmitted by said second radio frequency generator subcircuit; and

decoding means electrically connected between said radio signal receiver and said switch for generating a switching signal in response to said first and second intercepted signals.

16. The switching device according to claim 15, wherein said decoding means further comprises:

a memory for storage of one or more [signal profiles] signals; and

comparator means for determining whether said first or second intercepted signal matches said one or more [signal profiles] signals stored in said memory;

wherein said decoding means generates a switching signal in response to said first intercepted signal upon said comparator means determination that said first intercepted signal matches said one or more [signal profiles] signals stored in said memory;

[and wherein] said decoding means does not generate a switching signal in response to said second intercepted signal upon said comparator means determination that said second intercepted signal does not match any of said one or more [signal profiles] signals stored in said memory; and

[and wherein] said switch is adapted to change from said first position to said second position in response to said switching signal generated by said decoding means.

17. The switching system according to claim 16, wherein said [decoder] decoding means comprises:

a microprocessor for differentiating between said first intercepted signal and said second intercepted signal.

18. The switching system according to claim 17, wherein said [decoder] decoding means further comprises:

storage means for entering one or more [signal profiles] signals into said memory.

[19. The switching system according to claim 18, wherein said storage means further comprises:

a second radio signal receiver for intercepting said first and second signals transmitted by said first and second radio frequency generator subcircuits.]

20. A self-powered switching system comprising: an electroactive transducer having first and second ends, said electroactive transducer comprising;

a first electroactive member having opposing first and second electroded major faces and first and second ends;

a flexible substrate bonded to said second electroded major face of said first electroactive member; said flexible substrate having first and second ends adjacent said first and second ends of said first electroactive member;

wherein said electroactive transducer is adapted to deform from a first position to a second position upon application of a force to said electroactive transducer;

[and wherein] said electroactive transducer is adapted to return to said first position from said second position upon release of said force from said electroactive transducer;

[and wherein] upon said deformation and said return between said first and second positions, said electroactive transducer is adapted to generate an oscillating voltage potential between said first electroded major face and said second electroded major face;

29

a mounting member for retaining said first end of said electroactive transducer;
 said mounting member comprising:
 a plate adjacent said first end of said flexible substrate and said first *electroded* major face of said first electroactive member;
 [said mounting member comprising] retaining means adjacent said first end of said flexible substrate and opposite said second *electroded* major face of said first electroactive member;
a recess defining a depressed surface in said plate, said depressed surface substantially conforming to at least a portion of said first electroded major face of said electroactive member adjacent said first end of said flexible substrate and said first electroded major face of said first electroactive member; and
a conductive sheet within said recess, said conductive sheet being in electrical contact with said first electroded major face of said first electroactive member and a first conductor electrically connected to said first electroded major face of said first electroactive member;
 pressure application means for application of a force to said second end of said electroactive transducer, said pressure application means being adapted to apply a force sufficient to deform said electroactive transducer from said first position to said second position, thereby generating a first voltage potential;
 [a first conductor electrically connected to said first electroded major face of said first electroactive member;]
 a second conductor electrically connected to said second electroded major face of said first electroactive member;
 a rectifier electrically connected between said first and second conductors in parallel with said first and second electroded major faces of said *first* electroactive [transducer] member;
 a voltage regulator having an input side and an output side;
 said input side of said voltage regulator being electrically connected to an output side of said rectifier;
 first signal transmission means electrically connected to said output side of said voltage regulator;
 said first signal transmission means comprising a first radio frequency generator subcircuit connected to an antenna;
 signal reception means for receiving a first signal transmitted by said first signal transmission means;
 said signal reception means being adapted to generate a second signal in response to said first signal transmitted by said first signal transmission means;
 and
 a switch having a first position and a second position;
 said switch being in communication with said signal reception means; *and*
 said switch being adapted to change between said first position and said second position in response to said second signal.

21. The switching system according to claim 20, wherein said electroactive transducer is selected from the group comprising: piezoelectric transducers, ferroelectric transducers, unimorphs, bimorphs, monomorph benders, asymmetrically stress biased electroactive devices, prestressed electroactive devices, RAINBOW transducers, MOONIE transducers, and THUNDER actuators.

22. The switching system according to claim 20, wherein said pressure application means further comprises:

30

release means for removal of said force to said second end of said electroactive transducer, said release means being adapted to remove said force at said second position;
wherein
 [and wherein] said flexible substrate comprises a metallic substrate having a restoring force adapted to return said electroactive transducer to said first position; *and*
 [and wherein] upon said removal of said force from said second end of said electroactive transducer, said restoring force of said metallic substrate returns said electroactive transducer through said first position to a third position and decayingly oscillates to said first position, thereby generating said oscillating voltage potential.
 23. The switching system according to claim 20, further comprising:
 second signal transmission means having a second radio frequency generator subcircuit tunable to a second frequency;
 wherein said first radio frequency generator subcircuit is tunable to a first frequency different from said second frequency of said second radio frequency generator subcircuit.
 24. The switching system according to claim 20, wherein said pressure application means is selected from the group comprising: manual pressure; rollers; pressure plates; toggles; hinges; knobs; sliders; ratchets; twisting mechanisms; release latches; spring loaded devices; foot pedals; game consoles; traffic activated devices; and seat activated devices.
 25. The switching system according to claim 20, further comprising:
 electrical energy storage means having a first and a second terminal;
 said first terminal of said electrical energy storage means being electrically connected to the output side of said voltage regulator;
 said second terminal of said electrical energy storage means being electrically connected to ground;
 [whereby] *wherein* said electrical energy storage means [may store] stores an electrical output of said voltage regulator.
 26. The switching system according to claim 25, further comprising:
 trigger means connected between said pressure application means and said first signal transmission means;
 and wherein said electrical energy storage means is adapted to supplement said output electrical signal of said voltage regulator to said first signal transmission means.
 27. The switching system according to claim 20, further comprising:
 electrical energy storage means having a first and a second terminal;
 said first terminal of said electrical energy storage means being electrically connected to the output side of said rectifier; *and*
 said second terminal of said electrical energy storage means being electrically connected to ground;
 [whereby] *wherein* said electrical energy storage means may store an electrical output of said rectifier.
 28. The switching system according to claim 27, wherein said electrical energy storage means further comprises:
 at least one rechargeable battery.
 29. The switching system according to claim 20, wherein said signal transmission means further comprises:

31

a tone generator subcircuit having an input side and an output side;

said input side of said tone generator subcircuit being connected to said output side of said voltage regulator;

said output side of said tone generator subcircuit being connected to said first radio frequency generator subcircuit.

30. The switching system according to claim 29, wherein said tone generator subcircuit comprises:

an oscillator array having an input side and an output side; said input side of said oscillator array being connected to said output side of said voltage regulator;

a transistor having a grounded emitter and a base connected to said output side of said oscillator array; and an inductive loop of a third conductor having first and second ends;

wherein said first radio frequency generator subcircuit comprises a resonant subcircuit having a first and a second junction;

said resonant subcircuit having a first capacitor having a first plate and a second plate;

said first plate of said first capacitor being connected to said first end of said third conductor, thereby forming said first junction of said resonant subcircuit;

said second plate of said first capacitor being connected to said second end of said third conductor, thereby forming said second junction of said resonant subcircuit;

said first junction of said resonant subcircuit being connected to said output side of said voltage regulator;

said second junction of said resonant subcircuit being connected to a collector of said transistor; *and*

[and wherein] said first radio frequency generator subcircuit further comprises an inductor connected in series between said output side of said voltage regulator and said first junction of said resonant subcircuit.

31. The switching system according to claim 30, wherein said oscillator array further comprises an inverter array connected between said output side of said voltage regulator and said base of said transistor.

32. The switching system according to claim 29, wherein said first tone generator and said first radio frequency generator subcircuits comprise [a] at least one programmable encoder circuit.

33. The switching system according to claim 20, wherein said signal reception means further comprises:

a first radio signal receiver for intercepting said first signal transmitted by said first radio frequency generator subcircuit and a second signal transmitted by a second radio frequency generator subcircuit; and

decoding means electrically connected between said radio signal receiver and said switch for generating a switching signal in response to said first and second intercepted signals.

34. The switching system according to claim 33, wherein said decoding means further comprises:

a memory for storage of one or more [signal profiles] signals; and

comparator means for determining whether said first or second intercepted signal matches said one or more [signal profiles] signals stored in said memory;

wherein said decoding means generates a switching signal in response to said first intercepted signal upon said comparator means' determination that said first inter-

32

cepted signal matches said one or more [signal profiles] signals stored in said memory;

[and wherein] said decoding means does not generate a switching signal in response to said second intercepted signal upon said comparator means' determination that said second intercepted signal does not match any of said one or more [signal profiles] signals stored in said memory; *and*

[and wherein] said switch is adapted to change from said first position to said second position in response to said switching signal generated by said decoding means.

35. The switching system according to claim 34, wherein said [decoder] decoding means comprises:

a microprocessor for differentiating between said first intercepted signal and said second intercepted signal; and [;]

storage means for entering said one or more [signal profiles] signals into said memory.

[36. The switching system according to claim 35, wherein said storage means further comprises:

a second radio signal receiver for intercepting a third signal transmitted by a third radio frequency generator subcircuit.]

[37. A self-powered switching system, comprising: an electroactive transducer having first and second ends, said electroactive transducer comprising;

a first electroactive member having opposing first and second electroded major faces and first and second ends;

a flexible substrate bonded to said second major face of said first electroactive member; said flexible substrate having first and second ends adjacent said first and second ends of said first electroactive member;

wherein said electroactive transducer is adapted to deform from a first position to a second position upon application of a force to said electroactive transducer;

and wherein said electroactive transducer is adapted to return to said first position from said second position upon release of said force from said electroactive transducer;

and wherein upon said deformation from said first position to second position, said electroactive transducer is adapted to generate a first voltage potential between said first electroded major face and said second electroded major face;

and wherein upon said return from said first position to second position, said electroactive transducer is adapted to generate a second voltage potential between said first electroded major face and said second electroded major face;

a mounting member for retaining said first end, said second end or said first and second ends of said electroactive transducer;

said mounting member comprising at least one retaining means adjacent said first end, said second end or said first and second ends of said flexible substrate of said first electroactive member;

pressure application means for application of a force to said first end, said second end or between said first and second ends of said electroactive transducer, said pressure application means being adapted to apply a force sufficient to deform said electroactive transducer from said first position to said second position, thereby generating a first voltage potential;

33

a first conductor electrically connected to said first electroded major face of said first electroactive member;
 a second conductor electrically connected to said second electroded major face of said first electroactive member;
 a rectifier electrically connected between said first and second conductors in parallel with said first and second electroded major faces of said electroactive transducer;
 a voltage regulator having an input side and an output side;
 said input side of said voltage regulator being electrically connected to an output side of said rectifier;
 first signal transmission means electrically connected to said output side of said voltage regulator;
 said first signal transmission means comprising a first radio frequency generator subcircuit connected to an antenna;
 electrical energy storage means having a first and a second terminal;
 said first terminal of said electrical energy storage means being electrically connected to the output side of said voltage regulator;
 said second terminal of said electrical energy storage means being electrically connected to ground;
 whereby said electrical energy storage means may store an electrical output of said voltage regulator;
 and wherein said electrical energy storage means is adapted to supplement said electrical output of said voltage regulator to said first signal transmission means with said stored output electrical signal of said voltage regulator;
 signal reception means for receiving a first signal transmitted by said first signal transmission means;
 said signal reception means being adapted to generate a second signal in response to said first signal transmitted by said first signal transmission means;
 and
 a switch having a first position and a second position;
 said switch being in communication with said signal reception means;
 said switch being adapted to change between said first position and said second position in response to said second signal.]

[38. A self-powered switching system, comprising:
 an electroactive transducer having first and second ends,
 said electroactive transducer comprising;
 a first electroactive member having opposing first and second electroded major faces and first and second ends;
 a flexible substrate bonded to said second major face of said first electroactive member;
 said flexible substrate having first and second ends adjacent said first and second ends of said first electroactive member;
 wherein said electroactive transducer is adapted to deform from a first position to a second position upon application of a force to said electroactive transducer;
 and wherein said electroactive transducer is adapted to return to said first position from said second position upon release of said force from said electroactive transducer;
 and wherein upon said deformation from said first position to second position, said electroactive transducer is adapted to generate a first voltage potential between said first electroded major face and said second electroded major face;

34

and wherein upon said return from said first position to second position, said electroactive transducer is adapted to generate a second voltage potential between said first electroded major face and said second electroded major face;
 a mounting member for retaining said first end, said second end or said first and second ends of said electroactive transducer;
 said mounting member comprising at least one retaining means adjacent said first end, said second end or said first and second ends of said flexible substrate of said first electroactive member;
 pressure application means for application of a force to said first end, said second end or between said first and second ends of said electroactive transducer, said pressure application means being adapted to apply a force sufficient to deform said electroactive transducer from said first position to said second position, thereby generating a first voltage potential;
 a first conductor electrically connected to said first electroded major face of said first electroactive member;
 a second conductor electrically connected to said second electroded major face of said first electroactive member;
 a rectifier electrically connected between said first and second conductors in parallel with said first and second electroded major faces of said electroactive transducer;
 a voltage regulator having an input side and an output side;
 said input side of said voltage regulator being electrically connected to an output side of said rectifier;
 first signal transmission means electrically connected to said output side of said voltage regulator;
 said first signal transmission means comprising a first radio frequency generator subcircuit connected to an antenna;
 electrical energy storage means having a first and a second terminal;
 said first terminal of said electrical energy storage means being electrically connected to the output side of said rectifier;
 said second terminal of said electrical energy storage means being electrically connected to ground;
 whereby said electrical energy storage means may store an electrical output of said rectifier;
 and wherein said electrical energy storage means is adapted to supplement said electrical output of said voltage regulator to said first signal transmission means with said stored output electrical signal of said voltage regulator;
 signal reception means for receiving a first signal transmitted by said first signal transmission means;
 said signal reception means being adapted to generate a second signal in response to said first signal transmitted by said first signal transmission means;
 and
 a switch having a first position and a second position;
 said switch being in communication with said signal reception means;
 said switch being adapted to change between said first position and said second position in response to said second signal.]

[39. The switching system according to claim 38, wherein said electrical energy storage means further comprises:
 at least one rechargeable battery.]

35

[40. A switching system, comprising:
 electromechanical generation means for generating an
 oscillating voltage across first and second electrical
 terminals;
 a rectifier electrically connected between said first and 5
 second electrical terminals;
 a voltage regulator having an input side and an output
 side;
 said input side of said voltage regulator being electri-
 cally connected to an output side of said rectifier; 10
 first signal transmission means electrically connected to
 said output side of said voltage regulator;
 said first signal transmission means comprising a first
 electromagnetic signal generator subcircuit con-
 nected to transmitter; 15
 signal reception means for receiving a first electromag-
 netic signal transmitted by said first signal transmission
 means;
 said signal reception means being adapted to generate
 a second signal in response to said first electromag- 20
 netic signal transmitted by said first signal transmis-
 sion means; and
 a switch having a first position and a second position;
 said switch being in communication with said signal
 reception means;
 said switch being adapted to change between said first
 position and said second position in response to said
 second signal.]

[41. The switching system according to claim 40, wherein
 said electromechanical generation means is selected from 30
 the group comprising: piezoelectric transducers, ferroelec-
 tric transducers, unimorphs, bimorphs, monomorph benders,
 asymmetrically stress biased electroactive devices, pre-
 stressed electroactive devices, RAINBOW transducers,
 MOONIE transducers, THUNDER actuators; rotary mag- 35
 netic generators; and
 linear magnetic generators.]

[42. The switching system according to claim 40, wherein
 said first signal transmission means comprises:
 a first radio frequency generator subcircuit connected to 40
 an antenna; and
 a tone generator subcircuit having an input side and an
 output side;
 said input side of said tone generator subcircuit being
 connected to said output side of said voltage regu- 45
 lator;
 said output side of said tone generator subcircuit being
 connected to said first radio frequency generator sub-
 circuit.]

[43. The switching system according to claim 40, further 50
 comprising:
 electrical energy storage means having a first and a second
 terminal;
 said first terminal of said electrical energy storage
 means being electrically connected to the output side 55
 of said voltage regulator;
 said second terminal of said electrical energy storage
 means being electrically connected to ground;
 whereby said electrical energy storage means may store
 an electrical output of said voltage regulator; 60
 and wherein said electrical energy storage means is
 adapted to supplement said electrical output of said
 voltage regulator to said first signal transmission means
 with said stored output electrical signal of said voltage
 regulator.]

[44. The switching system according to claim 43, wherein
 said electrical energy storage means further comprises:

36

at least one rechargeable battery.]

[45. The switching system according to claim 40, further
 comprising:

electrical energy storage means having a first and a second
 terminal;

said first terminal of said electrical energy storage
 means being electrically connected to the output side
 of said rectifier;

said second terminal of said electrical energy storage
 means being electrically connected to ground;

whereby said electrical energy storage means may store
 an electrical output of said rectifier;

and wherein said electrical energy storage means is
 adapted to supplement said electrical output of said
 voltage regulator to said first signal transmission means
 with said stored output electrical signal of said recti-
 fier.]

[46. The switching system according to claim 45, wherein
 said electrical energy storage means further comprises:
 at least one rechargeable battery.]

[47. The switching system according to claim 40, wherein
 said first tone generator and said first radio frequency
 generator subcircuits comprise a at least one programmable
 encoder circuit; 25

and wherein each of said first programmable encoder
 circuits is adapted to be programmed to generate one or
 more unique codes;

and wherein each of said unique codes generated by each
 of said first programmable encoder circuits is different
 from each of said unique codes generated by the others
 of said first programmable encoder circuits.]

[48. The switching system according to claim 47, further
 comprising:

second signal transmission means comprising a second at
 least one programmable encoder circuit connected to an
 antenna;

each of said second programmable encoder circuits
 comprising a radio frequency generator subcircuit
 and a tone generator subcircuit;

wherein each of said second programmable encoder cir-
 cuits is adapted to be programmed to generate one or
 more unique codes;

and wherein each of said unique codes generated by each
 of said second programmable encoder circuits is dif-
 ferent from each of said unique codes generated by
 each of said first programmable encoder circuits, and
 different from each of said unique codes generated by
 the others of said second programmable encoder cir-
 cuits.]

[49. The switching system according to claim 48, wherein
 said unique codes comprise operation codes selected from
 the group comprising: identification; toggle; on; off; dim;
 undim; operate; and a percentage of operating mode.]

[50. The switching system according to claim 48, wherein
 said one or more unique codes programmed into said first or
 second programmable encoder circuits are not changeable
 after initial programming of said one or more unique codes.]

[51. The switching system according to claim 48, wherein
 said one or more unique codes programmed into said first or
 second programmable encoder circuits are binary codes.]

[52. The switching system according to claim 48, where
 said signal reception means further comprises:

a first radio signal receiver for intercepting a code trans-
 mitted by said first or second signal transmission
 means;

37

decoding means electrically connected between said radio signal receiver and said switch for generating a switching signal in response to said first and second intercepted codes.]

[53. The switching system according to claim 52, wherein said decoding means further comprises:

a memory for storage of one or more signal profiles; and comparator means for determining whether said first or second intercepted codes matches said one or more signal profiles in said memory;

wherein said decoding means generates a switching signal in response to said first intercepted code upon said comparator means determination that said first intercepted code matches said one or more signal profiles in said memory;

and wherein said decoding means does not generate a switching signal in response to said second intercepted code upon said comparator means determination that said second intercepted code does not match any of said one or more signal profiles in said memory;

and wherein said switch is adapted to change from said first position to said second position in response to said switching signal generated by said decoding means.]

[54. The switching system according to claim 53, wherein said decoding means comprises:

a microprocessor for differentiating between said first intercepted code and said second intercepted code; and; storage means for entering one or more signal profiles into said memory.]

[55. The switching system according to claim 53, wherein said one or more signal profiles are selected from the group comprising: identification; toggle; on; off; dim; undim; operate; and a percentage of operating mode.]

[56. The switching system according to claim 53, wherein said signal reception means further comprises:

a signal relay transmitter for transmission of an actuation signal upon receipt of said switching signal generated by said decoding means; and

a second switch adapted to change from a first position to a second position in response to said actuation signal from said signal relay transmitter.]

[57. The switching system according to claim 53, further comprising:

a programming jumper having first and second ends for transmission of said unique codes from said signal transmission means to said memory for storage of said one or more signal profiles;

and wherein said signal transmission means comprises a transmitter jumper connection for connection of said first programmable encoder circuit to said first end of said programming jumper;

and wherein said signal reception means comprises a receiver jumper connection for connection of said memory to said second end of said programming jumper.]

[58. A self-powered switching system, comprising:

an electromechanical generator for generating a voltage across first and second electrical terminals;

a voltage regulator having an input side and an output side;

said input side of said voltage regulator being electrically connected to said first and second electrical terminals;

first signal transmission means electrically connected to said output side of said voltage regulator;

38

said first signal transmission means comprising a first electromagnetic signal generator subcircuit connected to a transmitter; and

a first tone generator subcircuit having an input side and an output side;

said input side of said tone generator subcircuit being connected to said output side of said voltage regulator;

said output side of said tone generator subcircuit being connected to said first electromagnetic signal generator subcircuit;

wherein said first tone generator and said first electromagnetic signal generator subcircuits comprise at least one programmable encoder circuit;

and wherein each of said first programmable encoder circuits is adapted to be programmed to generate one or more unique codes;

and wherein each of said unique codes generated by each of said first programmable encoder circuits is different from each of said unique codes generated by the others of said first programmable encoder circuits;

signal reception means for receiving a first electromagnetic signal transmitted by said first signal transmission means;

said signal reception means being adapted to generate a second signal in response to said first electromagnetic signal transmitted by said first signal transmission means; and

a switch having a first position and a second position; said switch being in communication with said signal reception means;

said switch being adapted to change between said first position and said second position in response to said second signal.]

[59. The switching system according to claim 58, further comprising:

second signal transmission means comprising a second at least one programmable encoder circuit connected to an antenna;

each of said second programmable encoder circuits comprising a second radio frequency generator subcircuit and a second tone generator subcircuit;

wherein each of said second programmable encoder circuits is adapted to be programmed to generate one or more unique codes;

and wherein each of said unique codes generated by each of said second programmable encoder circuits is different from each of said unique codes generated by each of said first programmable encoder circuits, and different from each of said unique codes generated by the others of said second programmable encoder circuits.]

60. A self-powered switching system, comprising:

a self-powered signal transmitter unit comprising:

an integral power source that is configured to generate electrical power;

a signal transmitter electrically powered by the integral power source and configured to generate and transmit a first switching signal and at least one second switching signal, the at least one second switching signal being different from the first switching signal;

an electrical energy storage device that is configured to store electrical energy, and that is adapted to supplement the electrical power output from the integral power source to power the signal transmitter;

39

an encoder circuit configured to select a first switching code, the first switching code being at least a thirty bit signal code for transmission by the signal transmitter in the first switching signal and to select at least one second switching code, the second switching code being at least a thirty bit signal code that is different from the first switching code for transmission as the second switching signal; and

a switching unit comprising:

- a signal receiver unit configured to receive the first switching signal;
- a signal comparing circuit configured to compare the at least the thirty bit signal code in the first switching signal to a pre-determined code in the switching unit to identify a first signal code match; and
- a first relay switching circuit configured to operate between a first operating mode and at least one second operating mode, the first relay switch cycling between the first operating mode and the at least one second operating mode when the signal comparing circuit identifies the first signal code match;

wherein the system further comprises:

- at least one other signal receiver unit that is configured to receive the second switching signal;
- at least one other signal comparing circuit that is configured to compare the at least the thirty bit signal code in the at least one second switching signal to another pre-determined code to identify a second signal code match; and
- at least one second relay switch circuit that is configured to operate between a first position and at least one second position, the at least one second relay switch circuit cycling between the first position and the at least one second position when the signal comparing circuit identifies the second signal code match.

61. The self-powered switching system of claim 60, wherein the first operating mode and the at least one second operating mode include at least two of (1) an identification mode; (2) a toggle mode; (3) an ON mode; (4) an OFF mode; (5) a DIM mode; (6) an UNDIM mode; (7) a full power operation mode; and (8) a selectable percentage operation mode.

62. The self-powered switching system of claim 60, the signal transmitter comprising a first signal transmitter configured to generate and transmit the first switching signal, and at least one second signal transmitter separate from the first signal transmitter that is configured to generate and transmit the at least one second switching signal.

63. The self-powered switching system of claim 60, the electrical energy storage device comprising at least one rechargeable battery.

64. The self-powered switching system of claim 60, the self-powered signal transmitter unit further comprising a signal training device that operates to enable a training mode of operation in which a separate switching code is transmitted to the switching unit to be set as the pre-determined code in the switching unit.

65. The self-powered switching system of claim 60, the encoder circuit being configured to select only one first switching code.

66. The self-powered switching system of claim 60, the signal receiver unit being further configured to receive the at least one second switching signal; the signal comparing circuit comparing the at least the thirty bit signal code in the at least one second switch-

40

ing signal to a pre-determined code in the switching unit to identify a second signal code match; and the first relay switch circuit cycling between the first position and the at least one second position when the signal comparing circuit identifies the second signal code match.

67. The self-powered switching system of claim 60, the first relay switch circuit driving a physical switching unit between a first position and at least one second position for the physical switching unit.

68. A self-powered switching system, comprising:

- a self-powered signal transmitter unit comprising:
 - an integral power source that is configured to generate electrical power;
 - a signal transmitter electrically powered by the integral power source and configured to generate and transmit a first switching signal and at least one second switching signal, the at least one second switching signal being different from the first switching signal;
 - an electrical energy storage device that is configured to store electrical energy, and that is adapted to supplement the electrical power output from the integral power source to power the signal transmitter;
 - an encoder circuit that is configured to select a first switching code among at least one billion separately-available signal codes for transmission by the signal transmitter as the first switching signal and to select at least one second switching code, the at least one second switching code being at least one other code that is different from the first switching code among the at least one billion separately-available signal codes for transmission as the at least one second switching signal; and

- a switching unit comprising:
 - a signal receiver unit that is configured to receive the first switching signal;
 - a signal comparing circuit that is configured to compare the first switching code in the first switching signal to a pre-determined signal code in the switching unit to identify a first signal code match; and
 - a first relay switch circuit that is configured to operate between a first position associated with a first operating mode and at least one second position associated with a respective at least one second operating mode, the first relay switching circuit cycling between the first position and the at least one second position when the signal comparing unit identifies the first signal code match;

wherein the system further comprises:

- at least one other signal receiver unit that is configured to receive the at least one second switching signal;
- at least one other signal comparing circuit that is configured to compare the at least one second signal code in the at least one second switching signal to another pre-determined code to identify a second signal code match; and
- at least one second relay switch circuit that is configured to operate between a first position and at least one second position, the at least one second relay switch circuit cycling between the first position and the at least one second position when the signal comparing circuit identifies the second signal code match.

69. The self-powered switching system of claim 68, wherein the first operating mode and the at least one second operating mode include at least two of (1) an identification

41

mode; (2) a toggle mode; (3) an ON mode; (4) an OFF mode; (5) a DIM mode; (6) an UNDIM mode; (7) a full power operation mode; and (8) a selectable percentage operation mode.

70. The self-powered switching system of claim 68, the signal transmitter comprising a first signal transmitter configured to generate and transmit the first switching signal, and at least one second signal transmitter separate from the first signal transmitter that is configured to generate and transmit the at least one second switching signal.

71. The self-powered switching system of claim 68, the electrical energy storage device comprising at least one rechargeable battery.

72. The self-powered switching system of claim 68, the self-powered signal transmitter unit further comprising a signal training device that operates to enable a training mode of operation in which a separate switching code is transmitted to the switching unit to be set as the pre-determined code in the switching unit.

42

73. The self-powered switching system of claim 68, the encoder circuit being configured to select only one first switching code.

74. The self-powered switching system of claim 68, the signal receiver unit being further configured to receive the at least one second switching signal;

the signal comparing circuit comparing the at least one second signal code in the at least one second switching signal to a pre-determined code in the switching unit to identify a second signal code match; and

the first relay switch circuit cycling between the first position and the at least one second position when the signal comparing circuit identifies the second signal code match.

75. The self-powered switching system of claim 68, the first relay switch circuit driving a physical switching unit between a first position and at least one second position for the physical switching unit.

* * * * *