

US00RE46482E

(19) **United States**  
(12) **Reissued Patent**  
**Sun et al.**

(10) **Patent Number:** **US RE46,482 E**  
(45) **Date of Reissued Patent:** **\*Jul. 18, 2017**

(54) **METHOD AND APPARATUS FOR CONTROLLING LOOP FILTERING OR POST FILTERING IN BLOCK BASED MOTION COMPENSATED VIDEO CODING**

*H04N 19/573* (2014.11); *H04N 19/577* (2014.11); *H04N 19/61* (2014.11);  
(Continued)

(71) Applicant: **Dolby Laboratories Licensing Corporation**, San Francisco, CA (US)

(58) **Field of Classification Search**  
CPC ..... G06T 9/004; H04N 19/51  
USPC ..... 375/240.16, 240.18, 240.25, 240.29;  
382/233, 236, 239, 254, 264, 266, 268,  
382/269

(72) Inventors: **Shijun Sun**, Redmond, WA (US);  
**Shawmin Lei**, Camas, WA (US)

See application file for complete search history.

(73) Assignee: **Dolby Laboratories Licensing Corporation**, San Francisco, CA (US)

(56) **References Cited**

(\*) Notice: This patent is subject to a terminal disclaimer.

U.S. PATENT DOCUMENTS

5,072,293 A 12/1991 De Haan et al.  
5,126,841 A \* 6/1992 Tanaka et al. .... 375/240.16  
(Continued)

(21) Appl. No.: **14/512,165**

FOREIGN PATENT DOCUMENTS

(22) Filed: **Oct. 10, 2014**

CA 2 374 523 7/2001  
EP 0 777 388 A2 12/1995

**Related U.S. Patent Documents**

(Continued)

Reissue of:

(64) Patent No.: **7,440,501**  
Issued: **Oct. 21, 2008**  
Appl. No.: **11/105,729**  
Filed: **Apr. 13, 2005**

OTHER PUBLICATIONS

Notice of Allowance mailed Jul. 18, 2014 for U.S. Appl. No. 11/641,910.

(Continued)

U.S. Applications:

(60) Continuation of application No. 13/954,817, filed on Jul. 30, 2013, now Pat. No. Re. 45,250, which is an  
(Continued)

*Primary Examiner* — Adam L Basehoar

(51) **Int. Cl.**  
*H04B 1/66* (2006.01)  
*H04N 19/117* (2014.01)

(Continued)

(57) **ABSTRACT**

Adjacent blocks are identified in an image. Coding parameters for the adjacent blocks are identified. Deblock filtering between the identified adjacent blocks is skipped if the coding parameters for the identified adjacent blocks are similar and not skipped if the coding parameters for the identified adjacent blocks are substantially different.

(52) **U.S. Cl.**  
CPC ..... *H04N 19/117* (2014.11); *H04N 19/136* (2014.11); *H04N 19/139* (2014.11); *H04N 19/196* (2014.11); *H04N 19/527* (2014.11);

**2 Claims, 5 Drawing Sheets**

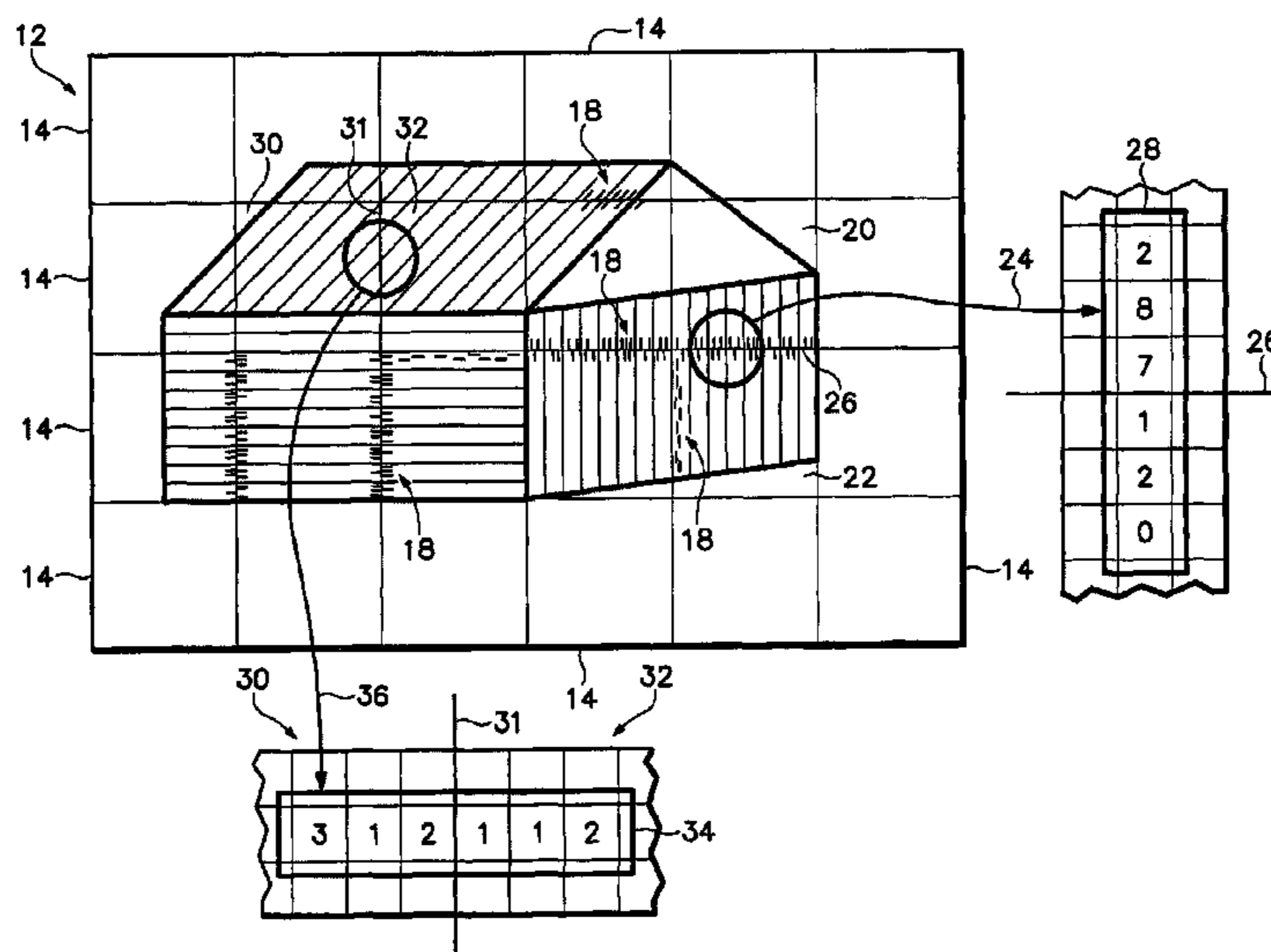

**Related U.S. Application Data**

application for the reissue of Pat. No. 7,440,501, and a continuation of application No. 13/495,944, filed on Jun. 13, 2012, now Pat. No. Re. 44,497, which is an application for the reissue of Pat. No. 7,440,501, and a continuation of application No. 12/908,690, filed on Oct. 20, 2010, now Pat. No. Re. 43,628, which is an application for the reissue of Pat. No. 7,440,501, which is a division of application No. 09/817,701, filed on Mar. 26, 2001, now Pat. No. 6,931,063.

7,319,415	B2 *	1/2008	Gomila .....	H04N 19/176 341/50
RE43,628	E	9/2012	Sun et al.	
RE44,497	E	9/2013	Sun et al.	
8,600,179	B2 *	12/2013	Park .....	H04N 19/176 382/239
2001/0017944	A1	8/2001	Kalevo et al.	
2002/0136303	A1 *	9/2002	Sun et al. ....	375/240.16
2004/0101059	A1	5/2004	Joch et al.	
2004/0190626	A1 *	9/2004	Sun et al. ....	375/240.18
2005/0002646	A1	1/2005	Sato	
2006/0146941	A1	7/2006	Cha et al.	
2007/0160133	A1	7/2007	Bao et al.	
2008/0240252	A1 *	10/2008	He .....	H04N 19/176 375/240.24

(51) **Int. Cl.**

<i>H04N 19/577</i>	(2014.01)
<i>H04N 19/196</i>	(2014.01)
<i>H04N 19/61</i>	(2014.01)
<i>H04N 19/136</i>	(2014.01)
<i>H04N 19/80</i>	(2014.01)
<i>H04N 19/82</i>	(2014.01)
<i>H04N 19/527</i>	(2014.01)
<i>H04N 19/895</i>	(2014.01)
<i>H04N 19/573</i>	(2014.01)
<i>H04N 19/139</i>	(2014.01)
<i>H04N 19/176</i>	(2014.01)
<i>H04N 19/86</i>	(2014.01)
<i>H04N 19/60</i>	(2014.01)
<i>H04N 19/132</i>	(2014.01)
<i>G06T 5/00</i>	(2006.01)

FOREIGN PATENT DOCUMENTS

EP	0 714 209	A2	5/1996
EP	0 777 388	A2	4/1997
EP	0 777 388	A2	6/1997
EP	0 838 955	A2	7/1997
EP	0 838 955	A2	4/1998
JP	5-227518		9/1993
JP	08-205178		8/1996
JP	8-265762	A	10/1996
JP	10-93966		4/1998
JP	10-191351		7/1998
JP	11-18085		1/1999
JP	11-275584		10/1999
JP	2000-59769	A	2/2000
JP	2000-299864		10/2000
JP	2001-94996		4/2001
JP	2001-204029		7/2001
JP	2001-224031		8/2001
JP	2004-328634	A	11/2004
JP	2005-503737	A	2/2005
JP	2006-191576		7/2006
KR	1997-0078645		12/1997
WO	WO 00/14685		3/2000

(52) **U.S. Cl.**

CPC ..... *H04N 19/80* (2014.11); *H04N 19/82* (2014.11); *H04N 19/895* (2014.11); *G06T 5/001* (2013.01); *H04N 19/132* (2014.11); *H04N 19/176* (2014.11); *H04N 19/60* (2014.11); *H04N 19/86* (2014.11)

(56)

**References Cited**

U.S. PATENT DOCUMENTS

5,329,318	A	7/1994	Keith	
5,367,385	A	11/1994	Yuan	
5,473,384	A	12/1995	Jayant et al.	
5,479,211	A	12/1995	Fukuda	
5,565,921	A	10/1996	Sasaki et al.	
5,654,759	A	8/1997	Augenbraun et al.	
5,731,840	A	3/1998	Kikuchi et al.	
5,737,019	A *	4/1998	Kim .....	375/240.25
5,768,433	A	6/1998	Bolton	
5,787,204	A	7/1998	Fukuda	
5,852,682	A	12/1998	Kim	
5,933,542	A	8/1999	Chang et al.	
5,949,908	A	9/1999	Sugahara	
5,974,196	A	10/1999	Chang et al.	
5,987,184	A	11/1999	Kweon et al.	
6,041,145	A	3/2000	Hayashi et al.	
6,044,177	A	3/2000	Herley	
6,057,884	A	5/2000	Chen et al.	
6,104,434	A	8/2000	Nakagawa et al.	
6,115,503	A	9/2000	Kaup	
6,144,700	A	11/2000	Kim	
6,160,503	A *	12/2000	Andrews et al. ....	341/94
6,167,157	A	12/2000	Sugahara	
6,263,026	B1	7/2001	Je-Chang et al.	
6,424,676	B1	7/2002	Kono et al.	
6,618,445	B1 *	9/2003	Peng et al. ....	375/240.25
6,665,346	B1	12/2003	Lee et al.	
6,748,113	B1	6/2004	Kondo et al.	
6,907,079	B2 *	6/2005	Gomila .....	H04N 19/176 375/240.12
7,120,197	B2 *	10/2006	Lin .....	H04N 19/136 375/240.29

OTHER PUBLICATIONS

Notice of Allowance mailed May 29, 2014 for U.S. Appl. No. 11/641,741.  
 Office Action dated Aug. 7, 2013 for U.S. Appl. No. 12/943,837.  
 Office Action dated Nov. 12, 2013 for U.S. Appl. No. 12/943,837.  
 Office Action for U.S. Appl. No. 11/641,910 dated Oct. 2, 2013.  
 Office Action mailed Mar. 11, 2014 for U.S. Appl. No. 11/641,910.  
 Office Action dated May 28, 2015, for U.S. Appl. No. 14/512,067.  
 "Working Draft 1.0 of 14496-10: 200x/AMD1 Scalable Video Coding" ITU Study Group 16—Video Coding Experts Group—ISO/IEC MPEG & ITU-T VCEG/ISO/IEC JTC1/SC29/ WG11 and ITU-T SG16 Q6), No. N6901, Feb. 5, 2005 (Feb. 5, 2005), XP030013621.  
 "Working Draft 4 of ISO/IEC 14496-10: 200x/Amd.3 Scalable Video Coding" ITU Study Group 16—Video Coding Experts Group—ISO/IEC MPEG & ITU-T VCEG(ISO/IEC JTC1/SC29/ WG11 and ITU-T SG16 Q6), No. N7555. Oct. 28, 2005 (Oct. 28, 2005), XP030014100 p. 118-p. 119.  
 "Index of /av-arch/video-site/0109\_San", Sep. 4, 2001, pp. 1-4, XP002606104, Retrieved from the Internet: URL:http://ftp.itu3.int/av-arch/video-site/0109\_San [retrieved on Oct. 4, 2005].  
 Bjontegaard G.: "H.26L Test Model Long Term No. 6 (TML-6) draft 0", ITU Telecommunication Standardization Sector, Eibsee, Germany, Jan. 9 (Jan. 9, 2001), pp. 1-35, generated Mar. 3, 2001.  
 Bjontegaard G.: "H.26L Test Model Long Term No. 7 (TML-7) draft 0" ITU—Telecommunications Standardization Sector, Study Group 16, Video Coding Experts Group; Document VCEG-M81, May 3, 2001; Austin Texas, USA Apr. 2-4, 2001.  
 Derviaux C et al.: "Blocking Artifact Reduction of DCT Coded Image Sequences Using a Visually Adaptive Postprocessing" Proceedings of the International Conference on Image Processing (ICIP), Lausanne, Sep. 16-19, 1996, New York, IEEE, US, vol. 1, Sep. 16, 1996 pp. 5-8.

(56)

## References Cited

## OTHER PUBLICATIONS

- European Search Report for EP02006295.6, Apr. 28, 2005.
- European Search Report for EP02798822.9, Oct. 17, 2005.
- European Search Report for EP05016012.6, Oct. 7, 2005.
- European Search Report for EP06019135.0, Aug. 30, 2007.
- European Search Report for EP06736425.7, Sep. 1, 2010.
- Francois E. et al.: "Extended Spatial Scalability" International Organisation for Standardisation Organisation International de Normalisation, ISO/IEC JTC1/SC29/WG11, Coding of Moving Pictures and Audio, ISO/IEC JTC1/SC29/WG11, MPEG-2005/M11669 Jan. 2005 Hong Kong.
- Han W. et al.: "Response of SVC CE-3: Interlayer prediction" ITU Study Group 16—Video Coding Experts Group—ISO/IEC MPEG & ITU-T VCEG (ISO/IEC JTC1/SC29/WG11 and ITU-T SG16 Q6), No. M11585, Jan. 11, 2005 (Jan. 11, 2005), XP030040330.
- He Y; Wu F; Li S; Zhong 7; Yang S: "H.26L—Based Fine Granularity Scalable Video Coding" Proceedings—IEEE International Symposium on Circuits and Systems, vol. 4, 2002, pp. IV-548-IV-551, XP002593544 ISSN:0271-4310.
- International Search Report for PCT/JP02/09306, Dec. 17, 2002.
- International Search Report for PCT/US2006/007105, Nov. 23, 2007.
- Kim C. et al.: "Simplified Loop Filter for Mobile Service (VCEG-M43)" ITU—Telecommunication Standardization Sector Study Group 16, VCEG-M43, Austin, Texas, Apr. 2-4, 2001, generated Mar. 28, 2001.
- Kim S. D. et al.: "A Deblocking Filter with Two Separate Modes in Block-Based Video Coding", IEEE Transactions on Circuits and Systems for Video Technology, vol. 9, No. 1, Feb. 1999; pp. 156-160.
- Lee Y. L. et al.: "Loop-filtering and post-filtering for low bit-rates moving picture coding" Image Processing, 1999. ICIP 99. Proceedings, 1999 International Conference on Kobe, Japan Oct. 24-28, 1999, Piscataway, NJ, USA, IEEE, US, vol. 1, Oct. 24, 1999.
- List P. et al. "H.26L Test Model Long Term No. 8.40 (TML-8.4), Software Module: loop-filter.c" ITU—Telecommunications Standardization Sector Study Group 16, VCEG, [Online] Aug. 29, 2001, pp. 1-3, XP002440062, Santa Barbara, CA, USA.
- List P. et al.: "Adaptive Deblocking Filter" IEEE Transactions on Circuits and Systems for Video Technology, IEEE Service Center, Piscataway, NJ, US LINKD-DOI: 10.1109/TCSVT. 2003.815175, vol. 13, No. 7, Jul. 1, 2003 (Jul. 1, 2003). pages 614-619, XP01122109.
- List P.: "Report of the Ad Hoc Committee on Loop Filter Improvement (VCEG-N08)" ITU Telecommunications Standardization Sector Study Group 16, VCEG-N008, [Online] Sep. 4, 2001, pp. 1-3, XP002347724 Santa Barbara, CA, USA, generated Aug. 8, 2001.
- Meier T. et al.: "Reduction of Blocking Artifacts in Image and Video Coding", IEEE Transactions on Circuits and Systems for Video Technology, vol. 9, No. 3, Apr. 1999; pp. 490-499.
- Park H. W. et al.: "A Postprocessing Method for Reducing Quantization Effects in Low Bit-Rate Moving Picture Coding", IEEE Transactions on Circuits and Systems for Video Technology, IEEE Inc. New York, US, vol. 9, No. 1, Feb. 1999 (Feb. 1999), pp. 161-171.
- Suehring, Karsten, "Release of reference software TML 8.4", tml84changes.txt, Sep. 3, 2001, XP002606232, Retrieved from the Internet: URL: [http://wftp3.itu.int/av-arch/video-site/h26L/older\\_tml/tml8changes.txt](http://wftp3.itu.int/av-arch/video-site/h26L/older_tml/tml8changes.txt) [retrieved on Oct. 20, 2010].
- Sun S. et al.: "Extended Spatial Scalability with Picture-Level Adaptation," ITU Study Group 16—Video Coding Experts Group—ISO/IEC MPEG & ITU-T VCEG(ISO/IEC JTC1/SC29/WG11 and ITU-T SG16 Q6), No. JVT-O008, Apr. 13, 2005 (Apr. 13, 2005), XP030005956.
- Sun S. et al.: "Improved TML Loop Filter with Lower Complexity (VCEG-N17)" ITU Telecommunications Standardization Sector Study Group 16, VCEG-N17, [Online] Sep. 24, 2001, pp. 1-8, XP002347725 Santa Barbara, CA USA, generated Aug. 14, 2001.
- Sun S. et al.: "Loop Filter with Skip Mode (VCEG-M20)" ITU Telecommunications Standardization Sector Study Group 16, VCEG-M20, Apr. 2-4, 2001, pp. 1-8, XP002321426 Austin, Texas, USA, sections 1 + 2 with figure 1, generated Mar. 27, 2001.
- Sun S.: "CE2 Part 2: Deblocking filter for I\_BL Blocks Spatial Scalable Video Coding", ITU Study Group 16—Video Coding Experts Group—ISO/IEC MPEG & ITU-T VCEG(ISO/IEC JTC1/SC29/WG11 and ITU-T SG16 Q6), No. JVT-P013r1, Jul. 28, 2005 (Jul. 28, 2005), XP030006055.
- Turkowski K.: "Filters for Common Resampling Tasks," Graphics Gems I, Academic Press, Apple Computer, Apr. 1990.
- Video & JVT, Description of Core Experiments in SVC, International Organisation for Standardisation, Organisation International De Normalisation, Coding of Moving Pictures and Audio, ISO/IEC JTC1/SC29/WG11/N6898, Hong Kong, Jan. 2005.
- Bjontegaard, Gisle (Editor), "H.26L Test Model Long Term No. 6 (TML-6) draft0", ITU Telecommunications Standardization Sector, Study Group 16, Video Coding Experts Group (VCEG), 12<sup>th</sup> meeting, Eibsee, Germany, Jan. 9-12, 2001.
- European Search Report for European Application No. EP 02 00 6295, dated Apr. 20, 2005.

\* cited by examiner

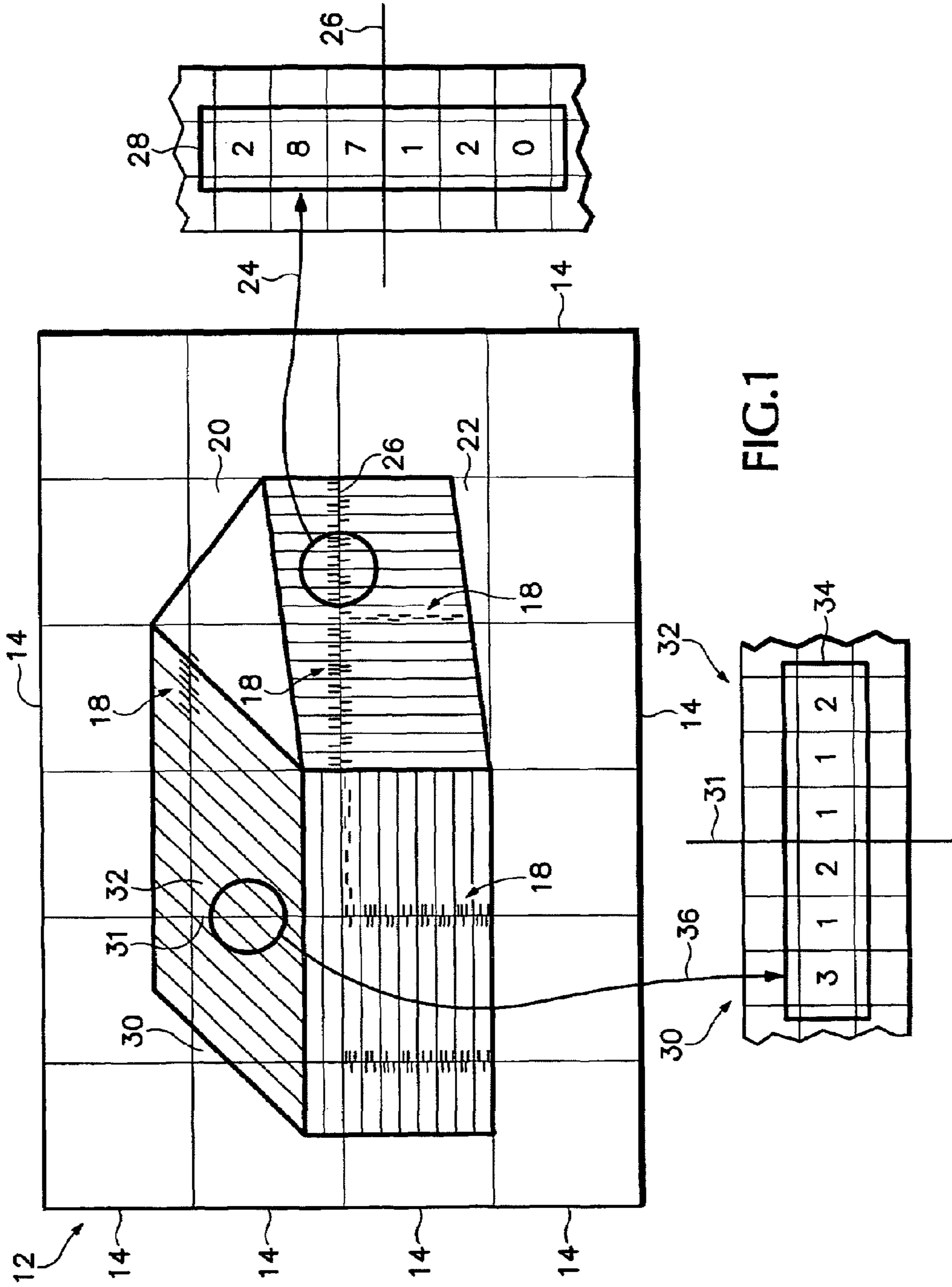

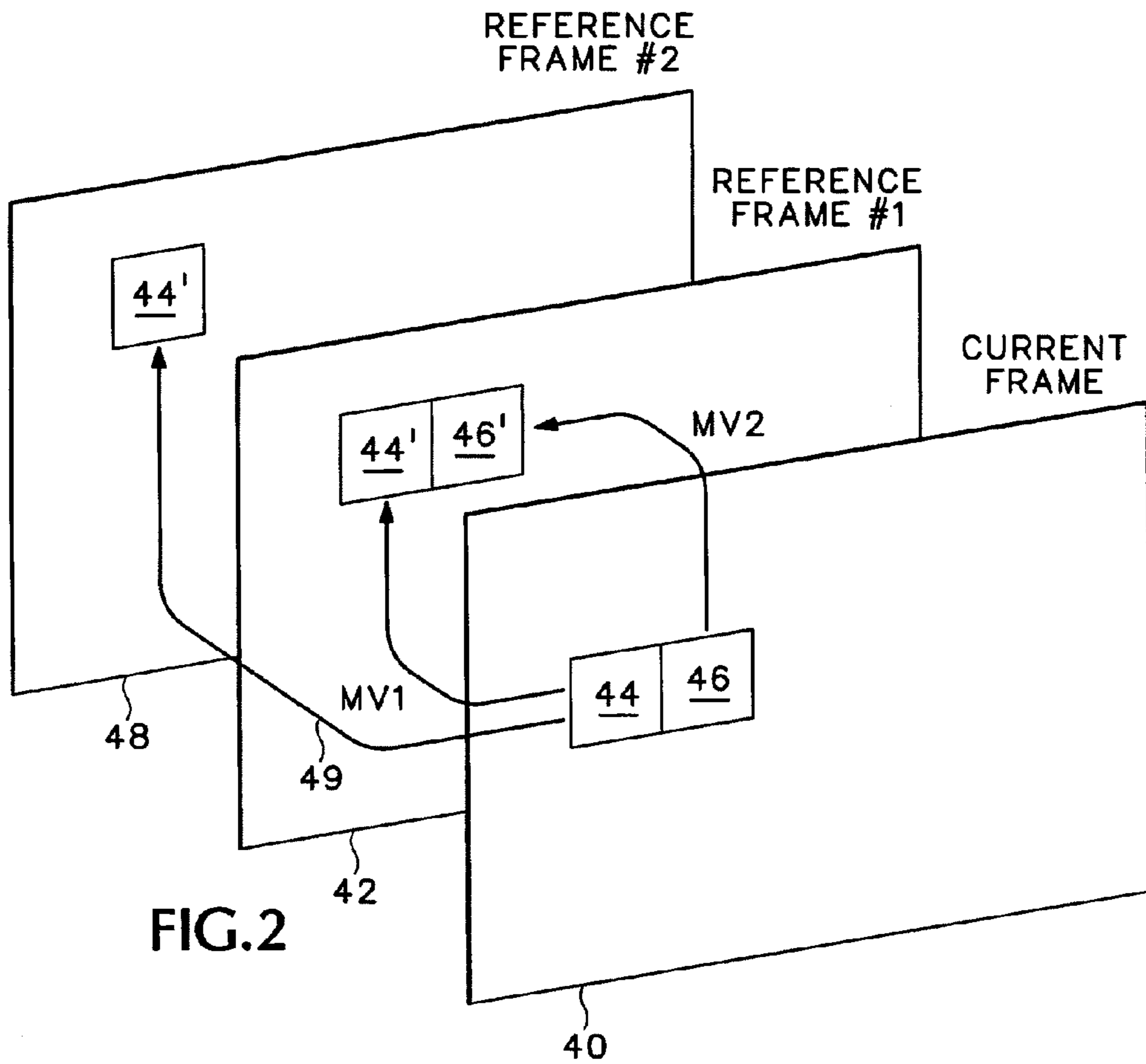

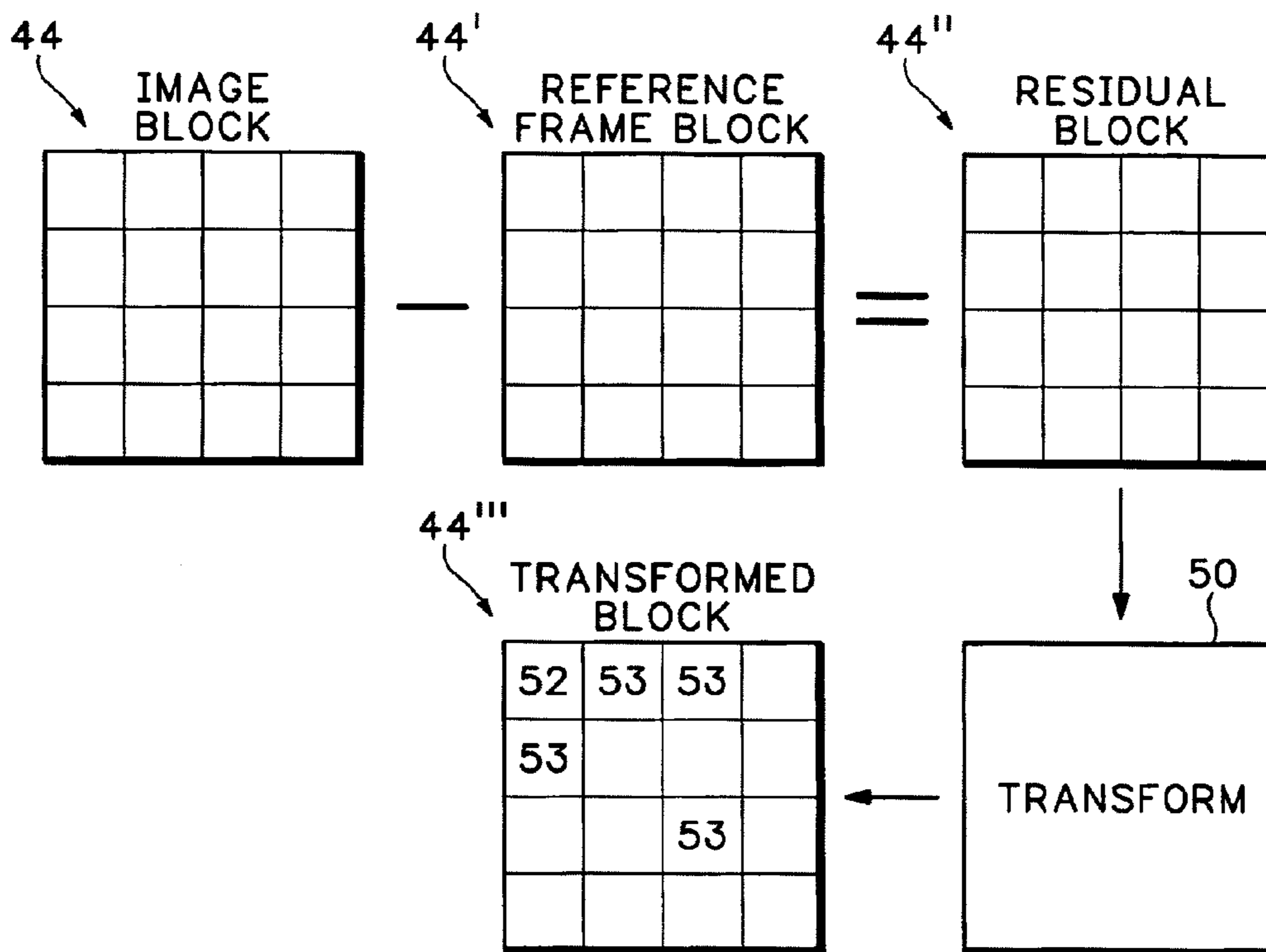

FIG.3

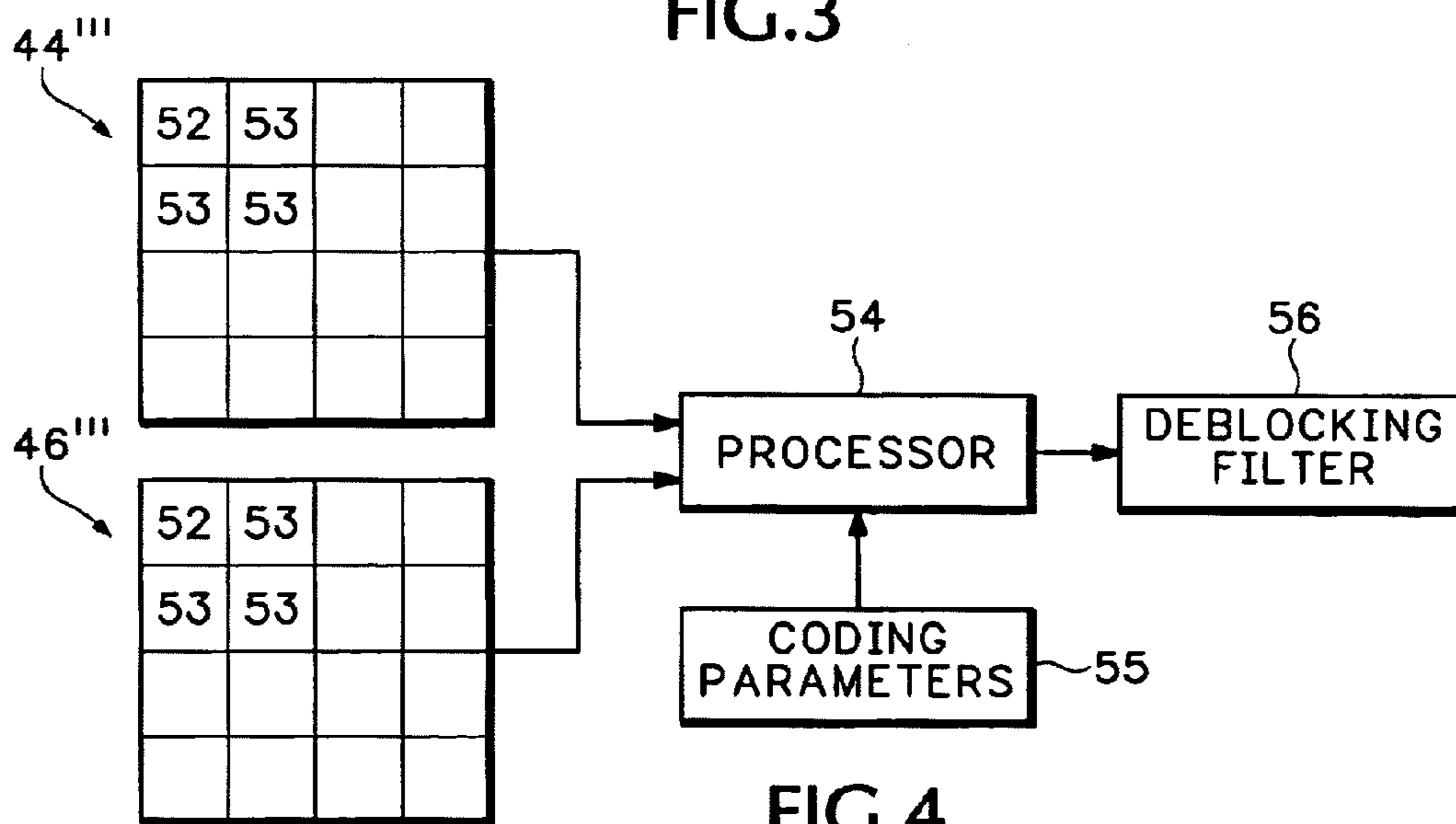
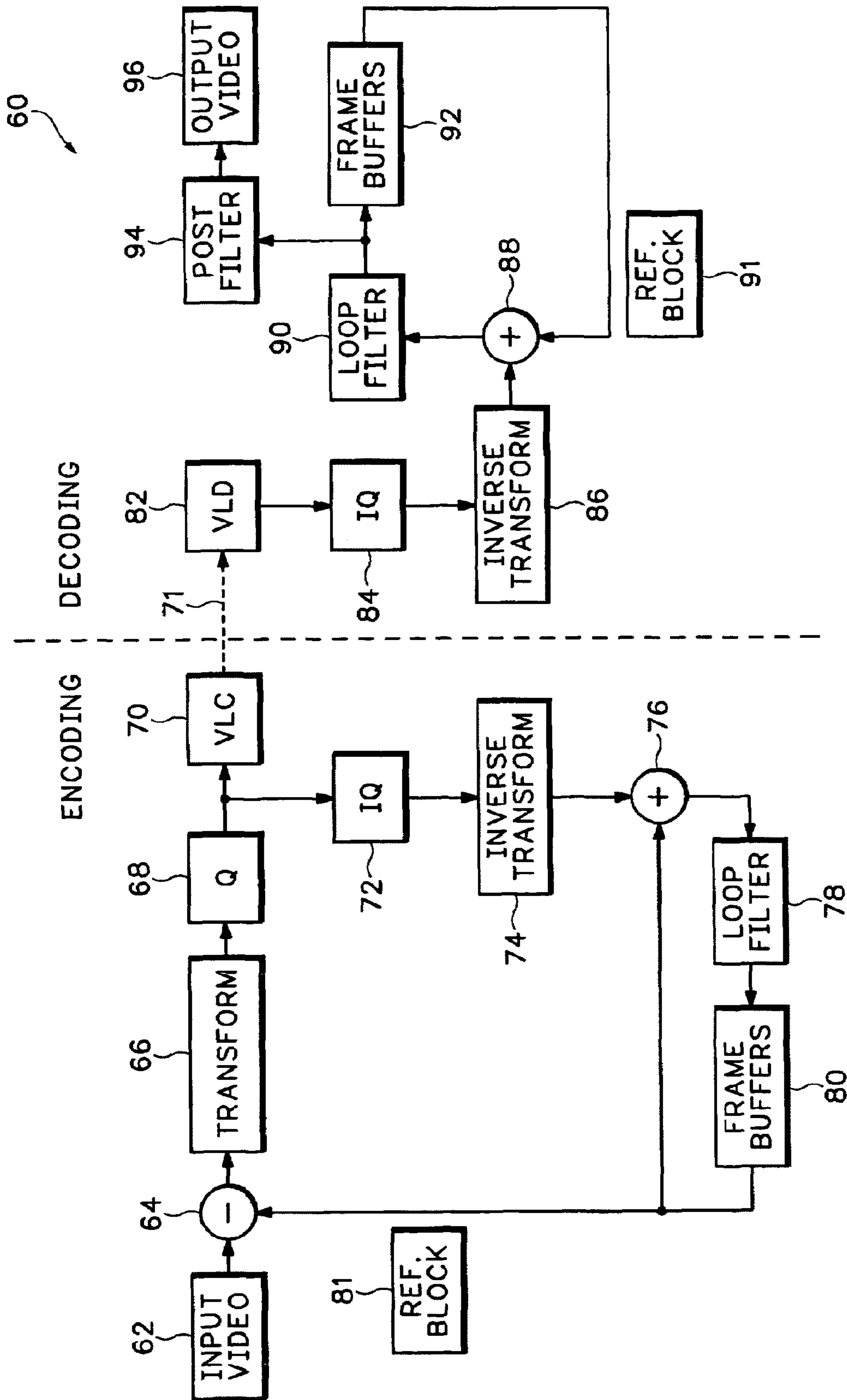

FIG.4



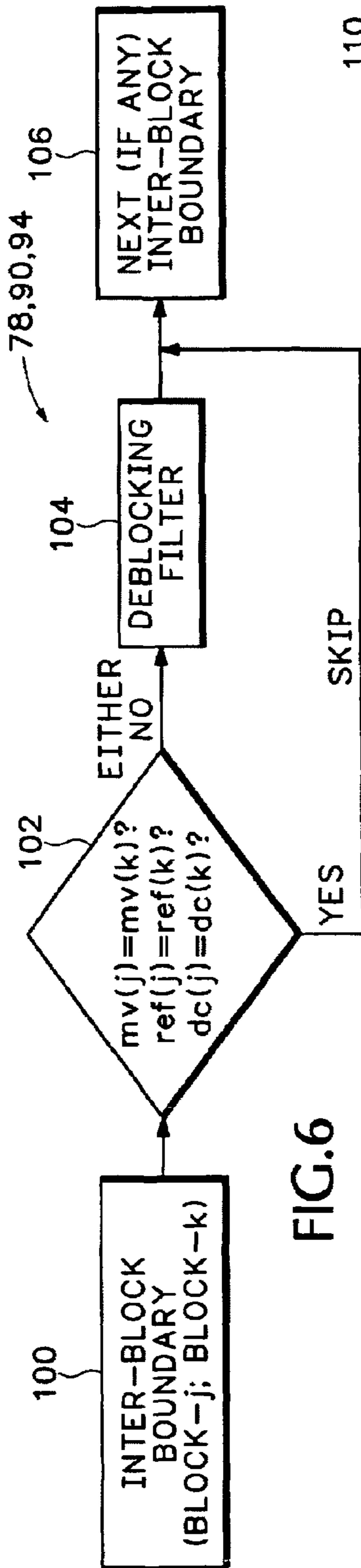

FIG.6

TABLE 1. COMPARISON BETWEEN TML AND THE PROPOSED LOOP FILTERING SCHEME

VIDEO SEQUENCE	QP	BITRATE (bps)		PSNR (Y)		PSNR (U)		PSNR (V)		NEW LOOP FILTER RELATIVE TIME SAVING
		TML	SLA	TML	SLA	TML	SLA	TML	SLA	
Akiyo_cif 300 FRAMES @ 30fps	25	33151	32346	34.050	34.161	38.934	39.042	40.300	40.369	63.0%
	30	22775	22295	30.797	30.920	36.610	36.964	38.680	38.771	68.2%
Foreman_cif 300 FRAMES @ 30fps	25	165115	162740	30.835	31.006	38.124	38.174	38.966	39.030	43.1%
	30	101357	100215	27.580	27.836	36.745	36.811	37.267	37.362	42.1%
Foreman_qcif 100 FRAMES @ 10fps	25	28681	28677	29.822	29.931	37.586	37.631	37.773	37.938	38.4%
	30	15999	15822	26.250	26.435	36.432	36.323	36.222	36.283	41.3%
Templete_cif 260 FRAMES @ 30fps	25	336200	329115	28.277	28.490	33.982	34.143	36.009	36.184	45.3%
	30	168133	159789	24.583	24.927	32.334	32.628	34.512	34.799	50.6%

FIG.7



**METHOD AND APPARATUS FOR  
CONTROLLING LOOP FILTERING OR  
POST FILTERING IN BLOCK BASED  
MOTION COMPENSATED VIDEO  
CODING**

**Matter enclosed in heavy brackets [ ] appears in the original patent but forms no part of this reissue specification; matter printed in italics indicates the additions made by reissue; a claim printed with strikethrough indicates that the claim was canceled, disclaimed, or held invalid by a prior post-patent action or proceeding.**

*More than one reissue applications have been filed for the reissue of U.S. Pat. No. 7,440,501. The reissue applications are: patent application Ser. No. 14/512,165 (the present application), filed on Oct. 10, 2014; patent application Ser. No. 12/908,690, filed on Oct. 20, 2010, now reissued as U.S. Pat. No. Re. 43,628; patent application Ser. No. 13/495,944, filed on Jun. 13, 2012, now reissued as U.S. Pat. No. Re. 44,497; patent application Ser. No. 13/954,817, filed on Jul. 30, 2013, now reissued as U.S. Pat. No. Re. 45,250; and co-pending patent application Ser. No. 14/512,067, filed on Oct. 10, 2014.*

**CROSS REFERENCE TO RELATED  
APPLICATIONS**

*This application is a continuation reissue application of application Ser. No. 13/954,817 filed Jul. 30, 2013 (now U.S. Pat. No. Re. 45,250), and is a reissue of U.S. Pat. No. 7,440,501. Patent application Ser. No. 13/954,817 is a continuation reissue application of application Ser. No. 13/495,944 filed on Jun. 13, 2012 (now U.S. Pat. No. Re. 44,497), and a reissue of U.S. Pat. No. 7,440,501. Patent application Ser. No. 13/495,944 is a continuation reissue application of application Ser. No. 12/908,690, filed on Oct. 20, 2010 (now U.S. Pat. No. Re. 43,628), and a reissue of U.S. Pat. No. 7,440,501. U.S. Pat. No. 7,440,501 was filed as application Ser. No. 11/105,729 on Apr. 13, 2005, and is a divisional [based on prior U.S.] of application Ser. No. 09/817,701, filed Mar. 26, 2001, now U.S. Pat. No. 6,931,063.*

**BACKGROUND**

Block based motion compensated video coding is used in many video compression standards such as H.261, H.263, H.263+, MPEG-1, MPEG-2, and H.26L. The lossy compression process can create visual artifacts in the decoded images, referred to as image artifacts. Blocking artifacts occur along the block boundaries in an image and are caused by the coarse quantization of transform coefficients.

Image filtering techniques can be used to reduce artifacts in reconstructed images. Reconstructed images are the images produced after being inverse transformed and decoded. The rule of thumb in these techniques is that image edges should be preserved while the rest of the image is smoothed. Low pass filters are carefully chosen based on the characteristic of a particular pixel or set of pixels surrounding the image edges.

Non-correlated image pixels that extend across image block boundaries are specifically filtered to reduce blocking artifacts. However, this filtering can introduce blurring artifacts into the image. If there are little or no blocking artifacts

between adjacent blocks, then low pass filtering needlessly incorporates blurring into the image while at the same time wasting processing resources.

The present invention addresses this and other problems associated with the prior art.

**SUMMARY OF THE INVENTION**

Adjacent blocks are identified in an image. Coding parameters for the adjacent blocks are identified. Deblock filtering between the identified adjacent blocks is skipped if the coding parameters for the identified adjacent blocks are similar and not skipped if the coding parameters for the identified adjacent blocks are substantially different.

**BRIEF DESCRIPTION OF THE DRAWINGS**

FIG. 1 is a diagram showing how deblock filtering is selectively skipped according to similarities between adjacent image blocks.

FIG. 2 is a diagram showing two adjacent image blocks having similar motion vectors.

FIG. 3 is a diagram showing how transform coefficients are identified for one of the image blocks.

FIG. 4 is a diagram showing how residual transform coefficients are compared between two adjacent image blocks.

FIG. 5 is a block diagram showing how the video image is encoded and decoded.

FIG. 6 is a block diagram showing how deblock filtering is selectively skipped in a codec.

FIG. 7 shows a table containing the results from selective deblock filter skipping.

**DETAILED DESCRIPTION**

In conventional filtering methods, filter processing only considers a single reconstructed image frame at a time. The motion-vector information available at both the encoder and decoder is not used. If two adjacent blocks share the same motion vector with respect to the same reference image frame, (for a multiple reference frames system) there may be no significant difference between the image residuals of each block. The block boundary of these two adjacent blocks may have been filtered in the reference frame and should therefore not be filtered again for the current frame. If a deblock filter is used without considering this motion-vector information, the conventional filtering process might filter the same boundary again and again from frame to frame. This unnecessary filtering not only causes unnecessary blurring but also results in extra filter computations.

FIG. 1 shows an image 12 that selectively filters block artifacts according to similarities between image blocks. The image 12 includes multiple image blocks 14 that are each individually encoded before being stored, transmitted, etc. The borders between some of the blocks 14 include blocking artifacts 18. Blocking artifacts are any image discontinuities between blocks 14 that may be created by the encoding process. A low pass filter is used to reduce the blocking artifacts that exist at the borders of adjacent image blocks.

For example, blocking artifacts 24 exist between blocks 20 and 22. A low pass filter is used at the border 26 between blocks 20 and 22 to remove or reduce the blocking artifacts 24. The low pass filter in one example selects a group of pixels 28 from both sides of the border 26. An average pixel value is derived from the group of pixels 28. Then each individual pixel is compared to the average pixel value. Any

pixels in group **28** outside of a predetermined range of the average pixel value is then replaced with the average pixel value.

As described above, if there are little or no blocking artifacts **24** between the adjacent pixels, then the group of pixels **28** may be needlessly filtered causing blurring in the image and wasting processing resources. A skip mode filtering scheme uses the motion estimation and compensation information for adjacent image blocks. If the motion estimation and compensation information is similar, deblock filtering is skipped. This not only avoids unnecessary image blurring but also significantly reduces the required number of filtering operations.

For example, it is determined during the encoding process that adjacent image blocks **30** and **32** have similar coding parameters. Accordingly, deblock filtering is skipped for the groups of pixels **34** that extend across the border **31** between adjacent blocks **30** and **32**. Skip mode filtering can be used for any horizontal or vertical boundary between any adjacent blocks in image **12**.

FIG. **2** shows reference frames **42** and **48** and a current frame **40** that is currently being encoded or decoded. Coding parameters for blocks **44** and **46** are compared to determine whether deblock filtering should be skipped between the two adjacent blocks **44** and **46**. One encoding parameter that is compared is the Motion Vectors (MV) for the blocks **44** and **46**.

The motion vector **MV1** points from block **44** in current image frame **40** to an associated block **44'** in the reference image **42**. The motion vector **MV2** points from block **46** in current image frame **40** to an associated block **46'** in reference frame **42**. Skip mode filtering checks to see if the motion vectors **MV1** and **MV2** point to adjacent blocks in the same reference frame **42**. If the motion vectors point to adjacent blocks in the reference frame ( $MV1=MV2$ ), then deblock filtering is skipped. This motion vector information may be used along with other coding information to decide whether to skip deblock filtering between the two image blocks **44** and **46**.

More than one reference frame may be used during the encoding and decoding process. For example, there may be another reference frame **48**. The adjacent blocks **44** and **46** may have motion vectors pointing to different reference frames. In one embodiment, the decision to skip deblock filtering depends on whether the motion vectors for the two adjacent blocks point to the same reference frame. For example, image block **44** may have a motion vector **49** pointing to reference frame **48** and image block **46** may have the motion vector **MV2** pointing to reference frame **42**. Deblock filtering is not skipped in this example because the motion vectors **49** and **MV2** point to different reference frames.

FIG. **3** shows another coding parameter that may be used to decide whether or not to skip deblock filtering. The image block **44** from image frame **40** is compared with reference block **44'** from the reference frame **42** pointed to by the motion vector **MV1** as previously shown in FIG. **2**. A residual block **44''** is output from the comparison between image block **44** and reference block **44'**. A transform **50** is performed on the residual block **44''** creating a transformed block **44'''** of transform coefficients. In one example, the transform **50** is a Discrete Cosine Transform. The transformed block **44'''** includes a D.C. component **52** and A.C. components **53**.

The D.C. component **52** refers to a lowest frequency transform coefficient in image block **44**. For example, the coefficient that represents the average energy in the image

block **44**. The A.C. components **53** refer to the transform coefficients that represent the higher frequency components in the image block **44**. For example, the transform coefficients that represent the large energy differences between pixels in the image block **44**.

FIG. **4** shows the transformed residual blocks **44'''** and **46'''**. The D.C. components **52** from the two transformed blocks **44'''** and **46'''** are compared in processor **54**. If the D.C. components are the same or within some range of each other, the processor **54** notifies a deblock filter operation **56** to skip deblock filtering between the border of the two adjacent blocks **44** and **46**. If the D.C. components **52** are not similar, then no skip notification is initiated and the border between blocks **44** and **46** is deblock filtered.

In one embodiment, skip mode filtering is incorporated into the Telecommunications Sector of the International Telecommunication Union (ITU-T) proposed H.26L encoding scheme. The H.26L scheme only uses 4x4 integer Discrete Cosine Transform (DCT) blocks. Here, only the D.C. component of the two adjacent blocks may be checked. However some limited low frequency A.C. coefficients could also be checked when the image blocks are bigger sizes, such as 8x8 or 16x16 blocks. For example, the upper D.C. component **52** and the three lower frequency A.C. transform coefficients **53** for block **44'''** may be compared with the upper D.C. component **52** and three lower frequency A.C. transform coefficients **53** for block **46'''**. Different combinations of D.C. and/or low frequency A.C. transform coefficients can be used to identify the relative similarity between the two adjacent blocks **44** and **46**.

The processor **54** can also receive other coding parameters **55** that are generated during the coding process. These coding parameters include the motion vectors and reference frame information for the adjacent blocks **44** and **46** as described above. The processor **54** uses all of these coding parameters to determine whether or not to skip deblock filtering between adjacent image blocks **44** and **46**. Other encoding and transform functions performed on the image may be carried out in the same processor **54** or in a different processing circuit. In the case where all or most of the coding is done in the same processor, the skip mode is simply enabled by setting a skip parameter in the filtering routine.

FIG. **5** shows how skip mode filtering is used in a block-based motion-compensated Coder-Decoder (Codec) **60**. The codec **60** is used for inter-frame coding. An input video block from the current frame is fed from box **62** into a comparator **64**. The output of a frame buffering box **80** generates a reference block **81** according to the estimated motion vector (and possible reference frame number). The difference between the input video block and the reference block **81** is transformed in box **66** and then quantized in box **68**. The quantized transform block is encoded by a Variable Length Coder (VLC) in box **70** and then transmitted, stored, etc.

The encoding section of the codec **60** reconstructs the transformed and quantized image by first Inverse Quantizing (IQ) the transformed image in box **72**. The inverse quantized image is then inverse transformed in box **74** to generate a reconstructed residual image. This reconstructed residual block is then added in box **76** to the reference block **81** to generate a reconstructed image block. Generally the reconstructed image is loop filtered in box **78** to reduce blocking artifacts caused by the quantization and transform process. The filtered image is then buffered in box **80** to form reference frames. The frame buffering in box **80** uses the reconstructed reference frames for motion estimation and

compensation. The reference block **81** is compared to the input video block in comparator **64**. An encoded image is output at node **71** from the encoding section and is then either stored or transmitted.

In a decoder portion of the codec **60**, a variable length decoder (VLD) decodes the encoded image in box **82**. The decoded image is inverse quantized in box **84** and inverse transformed in box **86**. The reconstructed residual image from box **86** is added in the summing box **88** to the reference block **91** before being loop filtered in box **90** to reduce blocking artifacts and buffered in box **92** as reference frames. The reference block **91** is generated from box **92** according to the received motion vector information. The loop filtered output from box **90** can optionally be post filtered in box **94** to further reduce image artifacts before being displayed as a video image in box **96**. The skip mode filtering scheme can be performed in any combination of the filtering functions in boxes **78**, **90** and **94**.

The motion estimation and compensation information available during video coding are used to determine when to skip deblock filtering in boxes **78**, **90** and/or **94**. Since these coding parameters are already generated during the encoding and decoding process, there are no additional coding parameters that have to be generated or transmitted specially for skip mode filtering.

FIG. **6** shows is further detail how skip mode filtering is used in the filters **78**, **90**, and/or **94** in the encoder and decoder in FIG. **5**. The interblock boundary between any two adjacent blocks "j" and "k" is first identified in box **100**. The two blocks may be horizontally or vertically adjacent in the image frame. Decision box **102** compares the motion vector  $mv(j)$  for block j with the motion vector  $mv(k)$  for block k. It is first determined whether the two adjacent blocks j and k have the same motion vector pointing to the same reference frame. In other words, the motion vectors for the adjacent blocks point to adjacent blocks ( $mv(j)=mv(k)$ ) in the same reference frame ( $ref(j)=ref(k)$ ).

It is then determined whether the residual coefficients for the two adjacent blocks are similar. If there is no significant difference between the image residuals of the adjacent blocks, for example, the two blocks j and k have the same of similar D.C. component ( $dc(j)=dc(k)$ ), then the deblock filtering process in box **104** is skipped. Skip mode filtering then moves to the next interblock boundary in box **106** and conducts the next comparison in decision box **102**. Skip mode filtering can be performed for both horizontally adjacent blocks and vertically adjacent blocks.

In one embodiment, only the reference frame and motion vector information for the adjacent image blocks are used to determine block skipping. In another embodiment, only the D.C. and/or A.C. residual coefficients are used to determine block skipping. In another embodiment, the motion vector, reference frame and residual coefficients are all used to determine block skipping.

The skip mode filtering scheme can be applied to spatially sub-sampled chrominance channels. For example in a case with 4:2:0 color format sequences, skip mode filtering for block boundaries may only rely on the equality of motion vectors and D.C. components for the luminance component of the image. If the motion vectors and the D.C. components are the same, deblock filtering is skipped for both the luminance and chrominance components of the adjacent image blocks. In another embodiment, the motion vectors and the D.C. components are considered separately for each luminance and chrominance component of the adjacent blocks. In this case, a luminance or chrominance component for adjacent blocks may be deblock filtered while the other

luminance or chrominance components for the same adjacent blocks are not deblock filtered.

FIG. **7** includes a table **110** showing the results of skip mode filtering using a ITU-TH.26L Testing Model-Long TML5.0. Table **110** compares the results of the TML filtering standard with skip mode filtering as described above. Encoding results using skip mode filtering are shown in table **110** under the heading SLA.

There were four images that were tested, Akiyo\_cif for 300 frames at 30 Frames Per Second (fps), Foreman\_cif for 300 frames at 30 fps, Foreman\_qcif for 100 frames at 10 fps, and Tempete\_cif for 260 frames at 30 fps. Quantization Parameters (QP) of 25 and 30 were used. The results show no significant visual quality degradation with the skip mode filtering. The Picture Signal to Noise Ratio (PSNR) for the images stays approximately the same for the luminance Y and chrominance U and V channels. However, skip mode filtering provides time savings of 40-70 percent.

Skip mode filtering can be used with any system that encodes or decodes multiple image frames. For example, DVD players, video recorders, or any system that transmits image data over a communications channel, such as over television channels or over the Internet.

The skip mode filtering described above can be implemented with dedicated processor systems, micro controllers, programmable logic devices, or microprocessors that perform some or all of the operations. Some of the operations described above may be implemented in software and other operations may be implemented in hardware.

For the sake of convenience, the operations are described as various interconnected functional blocks or distinct software modules. This is not necessary, however, and there may be cases where these functional blocks or modules are equivalently aggregated into a single logic device, program or operation with unclear boundaries. In any event, the functional blocks and software modules or described features can be implemented by themselves, or in combination with other operations in either hardware or software.

Having described and illustrated the principles of the invention in a preferred embodiment thereof, it should be apparent that the invention may be modified in arrangement and detail without departing from such principles. Claim is made to all modifications and variation coming within the spirit and scope of the following claims.

The invention claimed is:

- [1.** A method for encoding an image, comprising:
  - identifying spatially adjacent blocks in a same frame of the image;
  - identifying transform coefficients for the spatially adjacent blocks in the same frame of the image;
  - comparing the transform coefficients between the spatially adjacent blocks in the same frame of the image;
  - skipping deblock filtering for removing image residuals to caused by encoding the image when the comparison indicates that the spatially adjacent blocks in the same frame of the image have same or similar transform coefficients; and
  - deblock filtering to remove image residuals between the identified spatially adjacent blocks when the comparison between the transform coefficients for the identified spatially adjacent blocks in the same frame of the image indicate that the spatially adjacent blocks do not have the same or similar transform coefficients.]
- [2.** A method according to claim **1** including:
  - identifying D.C. components in the transform coefficients;

7

comparing the D.C. components for the spatially adjacent blocks with each other; and skipping deblock filtering between the spatially adjacent blocks when the D.C. components for the compared spatially adjacent blocks have same or similar values relative to each other.]

[3. A method according to claim 1 including: identifying both D.C. and A.C. components in the transform coefficients; comparing the D.C. components for adjacent blocks and A.C. components for adjacent blocks; and skipping deblock filtering between the adjacent blocks when both the D.C. components are the same or similar and the A.C. components are the same or similar.]

[4. A method according to claim 1 including controlling deblock filtering for a loop filter in an image coder.]

[5. A method according to claim 1 including controlling deblock filtering in one or both of a loop filter and a post filter in an image decoder.]

[6. A method according to claim 1 including: identifying similarities between coding parameters in a luminance channel of the adjacent blocks; and controlling deblock filtering for both the luminance channel and a chrominance channel in the image according to identified similarities in the luminance channel.]

[7. A method according to claim 1 including selectively skipping deblock filtering in any one of a H.261, H.263, H263+, MPEG-1, MPEG-2, or H26L encoding standard according to encoding parameter similarities between adjacent image blocks.]

[8. An encoder for encoding an image, comprising: a processor adapted to:

compare blocks in a same image frame with reference frames;

transform a result of the comparison between the reference frames and the blocks in the image frame into transformed blocks having transform coefficients;

compare the similarities between the transform coefficients for spatially adjacent transformed blocks within the same image frame; and

skipping deblock filtering between spatially adjacent transformed blocks in the image that have the same or similar transform coefficients.]

[9. An encoder according to claim 8 wherein the processor is adapted to

identify motion vectors and associated reference frames for the adjacent blocks and skip deblock filtering between the spatially adjacent blocks according to the identified motion vectors and reference frames.]

[10. An encoder according to claim 8 wherein the processor is adapted to

identify residual coefficients for the spatially adjacent blocks and skip deblock filtering according to the identified residual coefficients.]

[11. An encoder according to claim 8 wherein the processor is adapted to skip deblock filtering according to both D.C. and A.C. components in the residual coefficients.]

[12. A decoder for decoding an encoded image, comprising:

a processor adapted to identify spatially adjacent blocks in the encoded image;

identify coding parameters including D.C. coefficients for the spatially adjacent blocks within a same encoded image frame;

compare the identified D.C. coefficients between the identified spatially adjacent blocks; and

8

enable or disable filtering of blocking artifacts between the spatially adjacent blocks according to the comparison of the D.C. coefficients between the spatially adjacent blocks within the same encoded image frame.]

[13. A decoder according to claim 12 wherein the processor is adapted to identify both D.C. coefficients and A.C. coefficients for the spatially adjacent blocks within a same encoded image frame;

compare the identified D.C. coefficients between the identified spatially adjacent blocks and compare the identified A.C. coefficients between the identified spatially adjacent blocks; and

enable or disable filtering of blocking artifacts between the spatially adjacent blocks according to the comparison of the D.C. coefficients between the adjacent blocks within the same encoded image frame and according to the comparison of the A.C. coefficients between the adjacent blocks within the same encoded image frame.]

[14. A decoder according to claim 12 wherein the processor is adapted to

identify residual coefficients for the spatially adjacent blocks and skip deblock filtering between the spatially adjacent blocks according to the identified residual coefficients.]

[15. A decoder according to claim 12 wherein the processor is adapted to

inverse transform the encoded image, compare blocks in the inverse transformed encoded image with reference frames, generate a reconstructed image from the comparison between the inverse transformed encoded image and the reference frame, and skip deblock filtering between spatially adjacent blocks in the reconstructed image according to the coding parameters for the spatially adjacent blocks.]

[16. A decoder according to claim 15 wherein the coding parameters include transform coefficients, motion vectors, and reference frame information and the processor skips deblock filtering when the transform coefficients, motion vectors, and reference frame information for the spatially adjacent blocks are the same or similar.]

[17. A decoder according to claim 12 wherein the processor is adapted to

skip deblock filtering in one or both of a loop filter and a post filter.]

18. *An image decoding apparatus, comprising one or more processors configured to:*

*store reference images for an image to be decoded, the stored reference images being for motion compensation prediction of the image to be decoded;*

*obtain a reference block from the stored reference images according to a motion vector;*

*decode an image from the reference block and a decoded difference block;*

*generate a reconstructed image based on the decoding;*

*and judge whether or not to execute deblock filtering for each boundary between adjacent blocks in the reconstructed image with respect to each of a luminance channel and a chrominance channel for the adjacent blocks, wherein*

*the judging includes determining, with respect to one of the luminance channel or the chrominance channel for the adjacent blocks, whether or not motion vectors of the adjacent blocks are equal to each other as well as whether or not the motion vectors of the adjacent blocks point to the same reference image, and*

9

*in response to determining that the motion vectors of the adjacent blocks are equal to each other and point to the same reference image, deblock filtering is not executed for a boundary of the adjacent blocks in the reconstructed image corresponding to the luminance channel* 5  
*and a boundary of the adjacent blocks in the reconstructed image corresponding to the chrominance channel.*

19. *An image decoding method, comprising:*  
*storing reference images for an image to be decoded, the stored reference images being for motion compensation prediction of the image to be decoded;* 10  
*obtaining a reference block from the stored reference images according to a motion vector;*  
*decoding an image from the reference block and a decoded difference block;* 15  
*generating a reconstructed image based on the decoding;*  
*and*  
*judging whether or not to execute deblock filtering for each boundary between adjacent blocks in the recon-*

10

*structed image with respect to each of a luminance channel and a chrominance channel for the adjacent blocks, wherein*

*the judging includes determining, with respect to one of the luminance channel or the chrominance channel for the adjacent blocks, whether or not motion vectors of the adjacent blocks are equal to each other as well as whether or not the motion vectors of the adjacent blocks point to the same reference image, and*

*in response to determining that the motion vectors of the adjacent blocks are equal to each other and point to the same reference image, deblock filtering is not executed for a boundary of the adjacent blocks in the reconstructed image corresponding to the luminance channel and a boundary of the adjacent blocks in the reconstructed image corresponding to the chrominance channel.*

\* \* \* \* \*